

# MD2134 Ultrasound Beamforming Transmitter Demoboard

## Introduction

The MD2134 is a high-speed, arbitrary waveform, push-pull source-driver. It is designed for medical ultrasound imaging and HIFU beam forming applications. It also can be used in NDT, sonar and other ultrasound phase-array focusing beam-forming applications.

The integrated circuit (IC) consists of the CMOS digital logic input circuits, an 8-bit current DAC for the waveform amplitude control, and four pre-stored Sine waveforms with pulse-amplitude-modulation (PAM) current sources. These current sources are constructed with the high-speed current-switch array and SPI programmable LV[15:1] PAM level registers. The PAM level resolution of the waveform is 7-bit, 128-step plus sign. There are four logic inputs M[3:0] as fast control signals. They control the push-pull current-source's output timing, frequency, cycle in the burst, as well as the current-level output. The 15 level registers, along with the DAC value, together can be written and read-back via a SPI serial interface.

The MD2134's output stage is designed to drive two depletion mode high voltage Supertex DN2625 N-type MOSFETs as the source drivers. The MOSFET drains are connected to a center-tap ultrasound frequency pulse transformer. The secondary winding of the transformer can connect to the ultrasound piezo or capacitive transducer via cable and with a good impedance match. MD2134 has a high-speed 120MHz serial data interface that can quickly update the beam forming apodization between scans.

## General Description

This demoboard datasheet describes how to use the MD-2134DB1 to generate the ultrasound transmit beam forming waveform with the Gaussian profile, and the adjustable frequency, amplitude and phase angle. It also provides information about how to design a user application circuit and PCB using the MD2134K7 and DN2625DK6 devices.

The MD2134DB1 circuit uses a pair of depletion mode, high voltage, DN2625 MOSFETs in the push-pull mode to drive the center-tap wide band ultrasound output transformer. The MOSFETs are in one 8-Lead DFN surface mount package. The sources of the MOSFETs are directly driven by the MD2134's two outputs, whose maximum peak sinking current is up to 3.3A. These current-source outputs are controlled by the MD2134's internal current source switch array and the input signals M[3:0].

All of the MD2134's logic control signals are generated by two small CPLD-programmable logic circuits clocked by an on-board 160MHz crystal oscillator. The on-board CPLD circuits not only generate accurate timing for the high-speed PAM level control waveforms, but also the serial data and clock to set and change the waveform amplitude DAC and waveform selection registers. The external clock input can be used if the on-board oscillator is disabled. The external trigger input can be used to synchronize the burst waveforms' launch timing.

There are five push buttons for enabling and selecting the output waveform selection (PAM), amplitude (DAC) and chip en-

## Demoboard Block Diagram

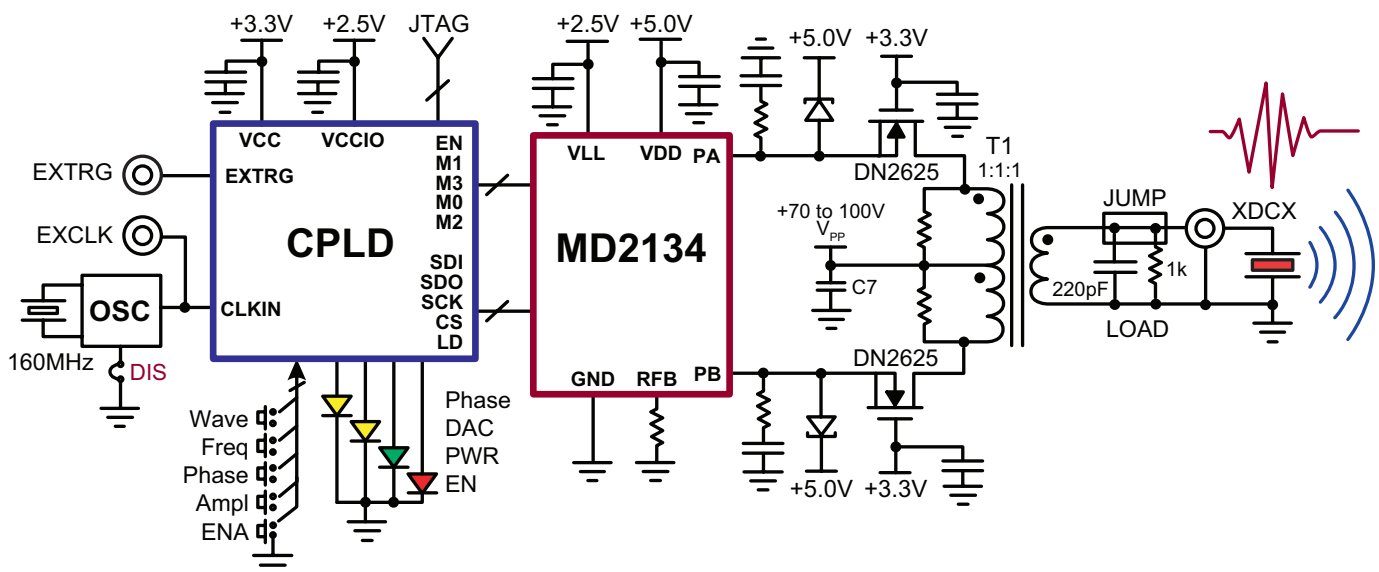

able (EN). The FREQ button is not being used for this revision of firmware. Four color LEDs indicate the power, chip enable, waveform selection, and DAC states. The MD2134DB1 output waveform can be displayed by using an oscilloscope and the high impedance probe at the TP13 test point. It also can use an SMA to BNC 50Ω coaxial cable connected directly to an oscilloscope, with an attenuation of 5:1 if  $R_{10}$  is 200Ω. A cable can also be used to drive the user's transducer directly. Jumper J4 can be used to select whether or not to connect the on-board equivalent-load, which is formed by a 220pF capacitor in parallel with a 1.0kΩ resistor.

## Circuit Design & PCB Layout

The thermal pad at the bottom of the MD2134 package must be connected to the VSUB pin on the PCB. The VSUB is connected to the IC's substrate. It is important to make sure that the VSUB is well grounded. A proper supply voltage power-up sequence is needed to test the circuit. To prevent any supply voltage polarity reversing, the circuit also has protection Schottky diodes (D7, D8 and D9).

Due to the high current and high current slew rate nature of this common gate, source-driven and push-pull circuit topology, the two cascading N-channel MOSFETs need to have very low lead inductance of the connections. The Supertex DN2625DK6 is designed for this application and works with the MD2134K7 seamlessly. In particular, a good PCB layout design needs to shorten the traces between the MD2134K7 output pins and the DN2625DK6 source pins. It is also necessary to connect all three pairs of pins between them for the high current carrying capacity. Furthermore, because of the high di/dt current in MD2134's outputs, it is also necessary to connect the Schottky diodes D5 and D6 from the driver output pins connected to the +5.0V power supply line, as the clamping diodes. Note that the diodes must have enough speed and peak current capability. The RC snubber circuits of R8-C5 and R15-C28 at the output pins can dump the current pulse edge ringing effectively.

PCB designers need to pay attention to some of the connecting traces as high-voltage and high-speed traces. In particular, low capacitance to the ground plane and more trace spacing needs to be applied in this situation.

High-speed PCB trace design practices that are compatible with about 100 to 200 MHz operating speed are used for the demoboard PCB layout. The internal circuitry of the MD2134 can operate at quite a high frequency, with the primary speed limitation being load capacitance. Because of this high speed and the high transient currents that result when driving even

very small inductive loads, ringing and even oscillations are possible. The supply voltage bypass capacitors and the MOSFET gate de-coupling capacitors should be as close to the pins as possible. The capacitor's ground pin pads should have low inductance, feed-through connections that are connected directly to a solid ground plane. The VDD and VPP supplies can draw fast transient currents of up to 3.5A, so they should be provided with a low-impedance bypass capacitor at the chip's pins. A ceramic capacitor of 0.1 to 1.0μF may be used. Minimize the trace length to the ground plane, and insert a ferrite bead in the power supply lead to the capacitor to prevent resonance in the power supply lines. For applications that are sensitive to jitter and noise and when using multiple MD2134 ICs, insert another ferrite bead between VDD and decouple each chip supply separately. Pay particular attention to minimizing trace lengths and using sufficient trace width to reduce inductance not only on the supply pins but also on the CA/B and KA/B compensation pins. Very closely placed surface mount components are highly recommended. Be aware of the parasitic coupling from the high voltage outputs to the input signal terminals of MD2134. This feedback may cause oscillations or spurious waveform shapes on the edges of signal transitions. Since the input operates with signals down to 2.5V, even small coupling voltages may cause problems. Use of a solid ground plane and good power and signal layout practices will prevent this problem. Also ensure that the circulating ground return current from a capacitive load cannot react with common inductance to create noise voltages in the input logic circuitry.

This MD2134DB1 demoboard should be powered up with multiple DC power supplies with current limiting functions. The power supply voltages and current limits used in the testing are listed on page 7. There are examples of the MD2134DB1 demoboard input and output waveform and measurements shown in Figures 1 to 7 below.

## Output Transformer Design

The center tap, wide band, ultrasound transformer for push-pull output circuit serves three functions: a balanced-differential to single-end output transformer; an isolation barrier to the ultrasound probe; and an impedance matching or low-pass network combined with the cable and transducer element. The MD2134 PAM clock may operate at a 80 to 160MHz frequency range, however the wide band transformer needs only to work in the frequency band of the dummy load (220pF//1.0k). Besides the bandwidth consideration, the small transformer should be designed using a ferrite magnetic core selected to give high enough saturation current and low leakage inductance.

Circuit Schematic

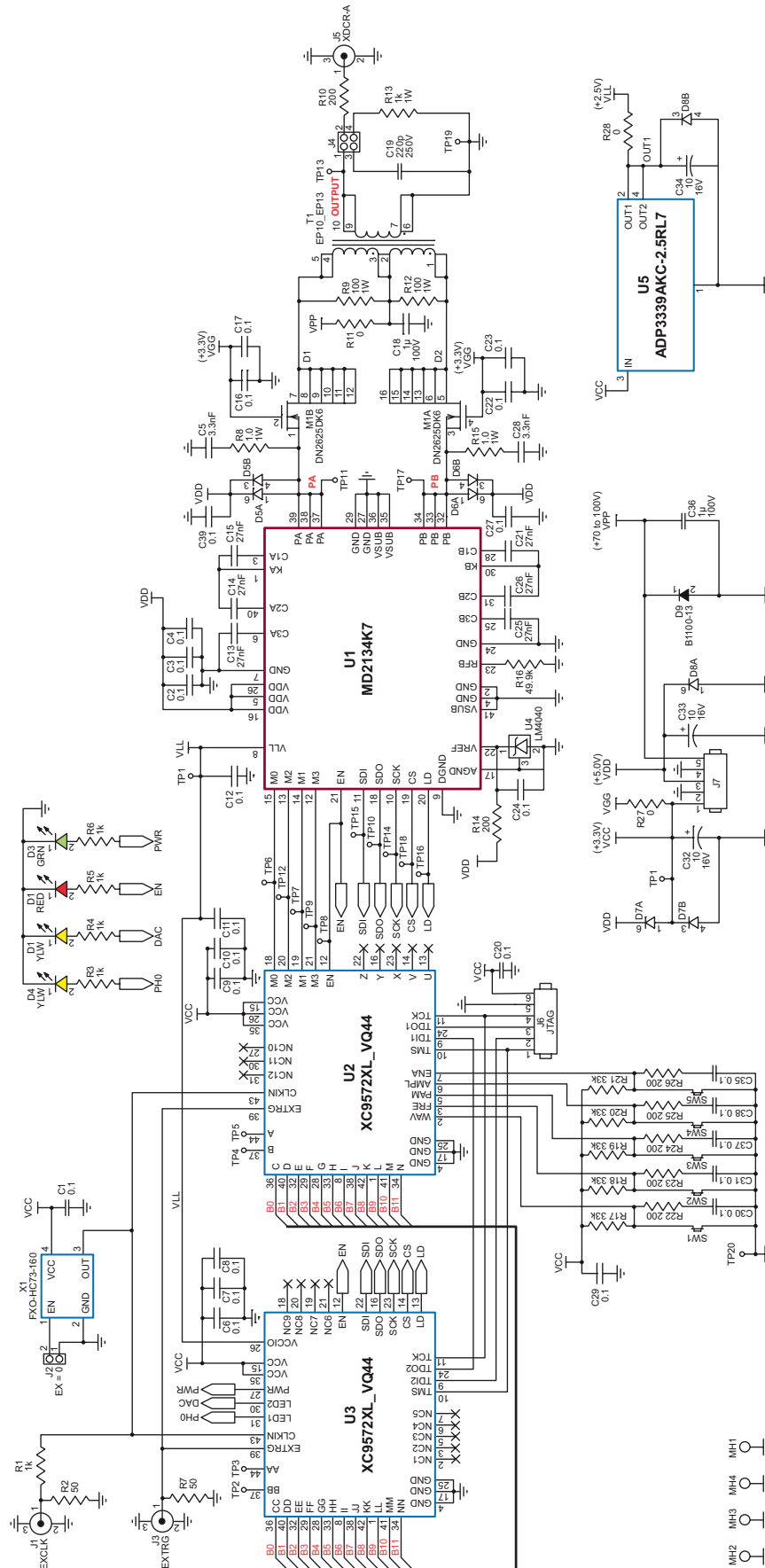

PCB Layout

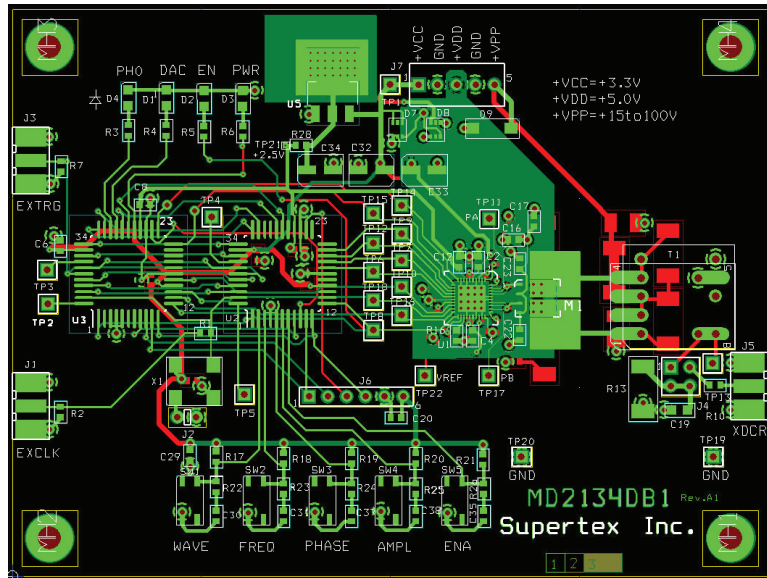

MD2134DB1 Demoboard

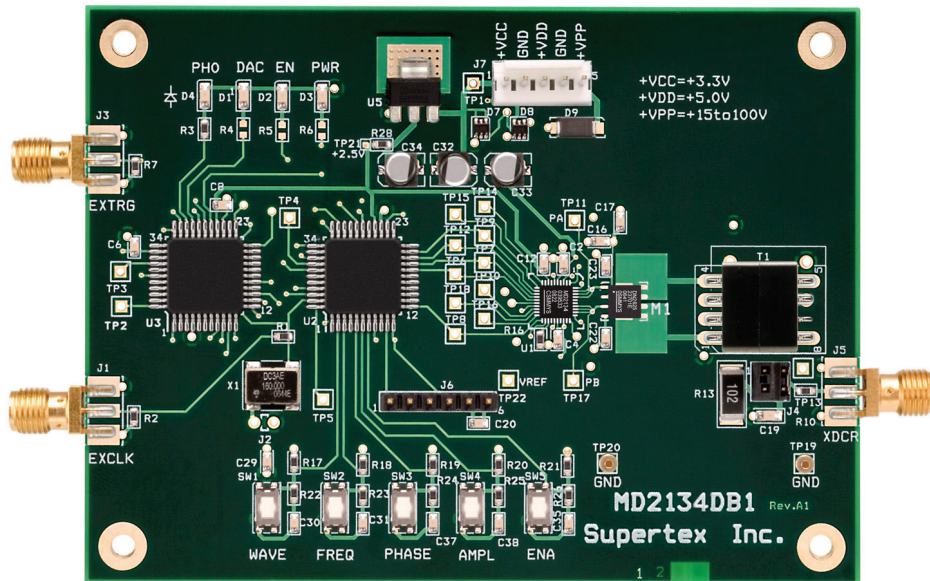

Actual Dimensions: 10.2cm x 7.6cm (4.00" x 3.00")

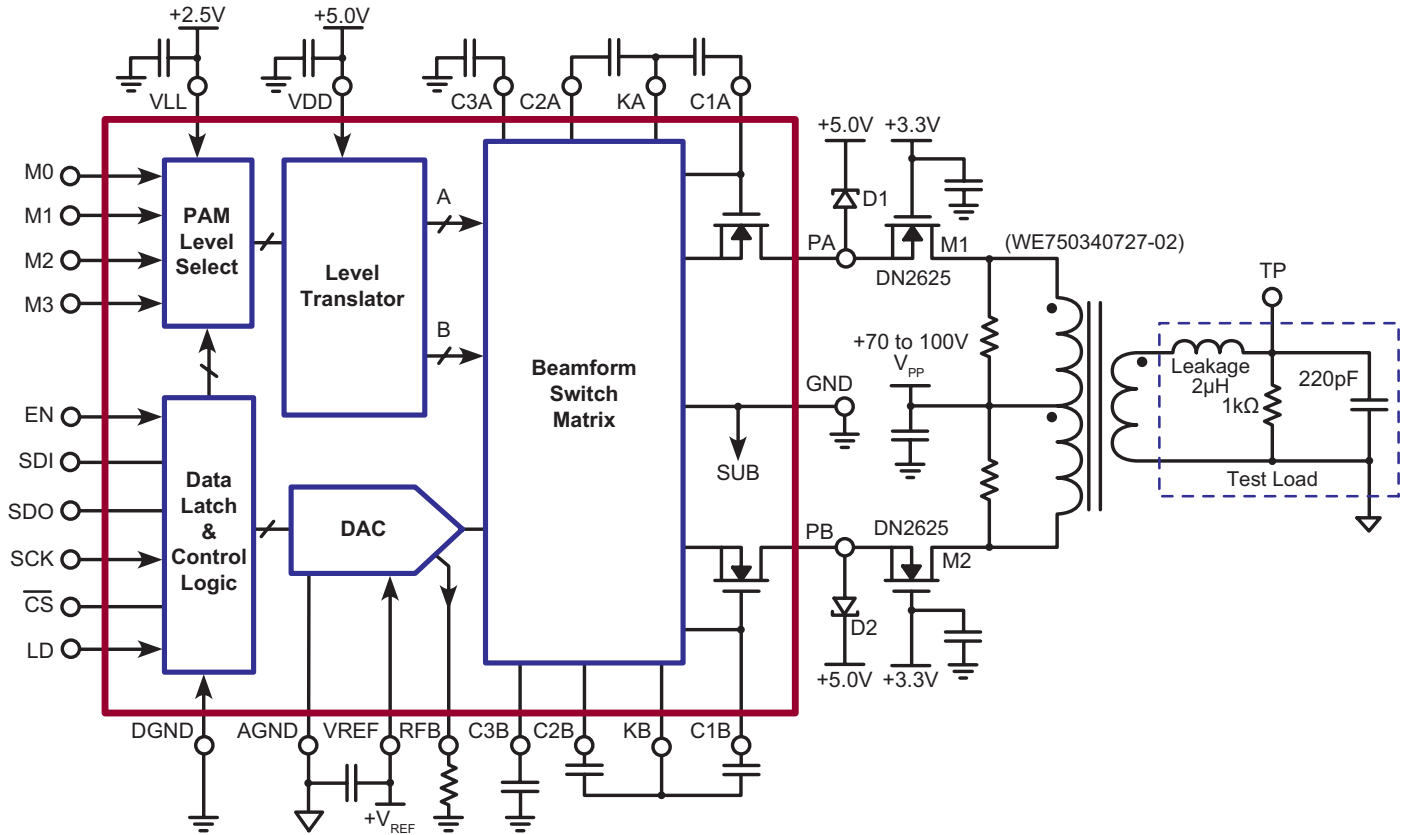

MD2134DB1 Input and Output Waveforms

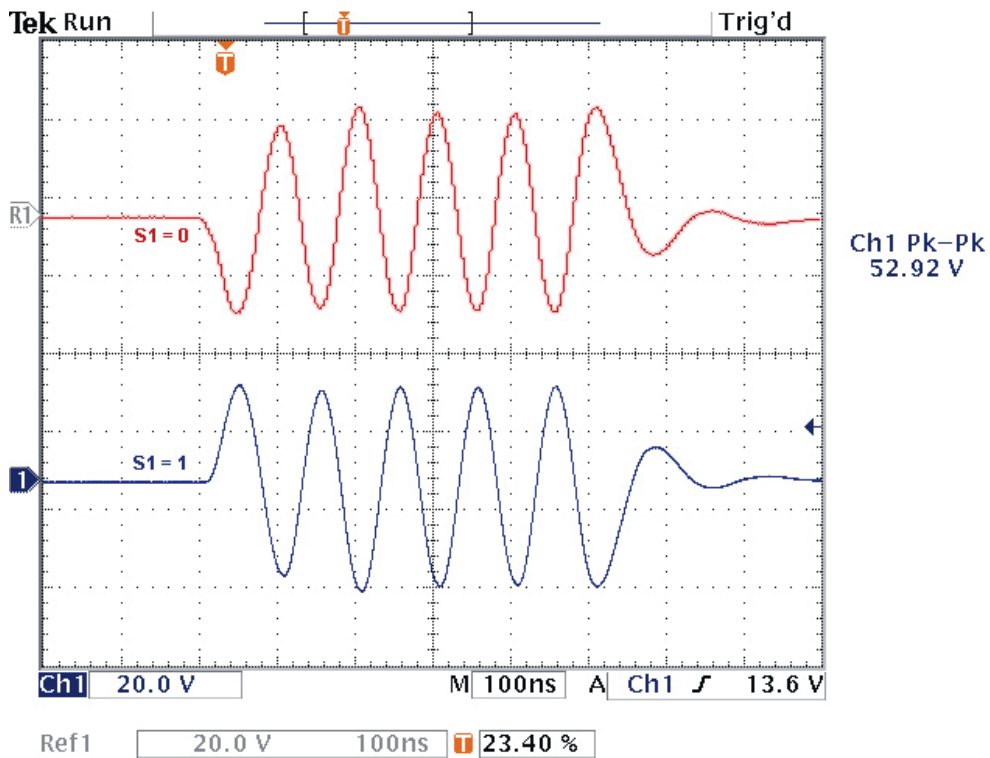

Figure 1: Output waveform of 16-sample/cycle  $f_s = 160\text{MHz}$ ,  $V_{pp} = 75\text{V}$ ,  $220\text{pF}/1.0\text{k}\Omega$  load.  
 LV = (0, -12, -12, -45, -45, -12, -12, 0, 0, 14, 14, 45, 45, 14, 14, 0, ...) 5 cycles



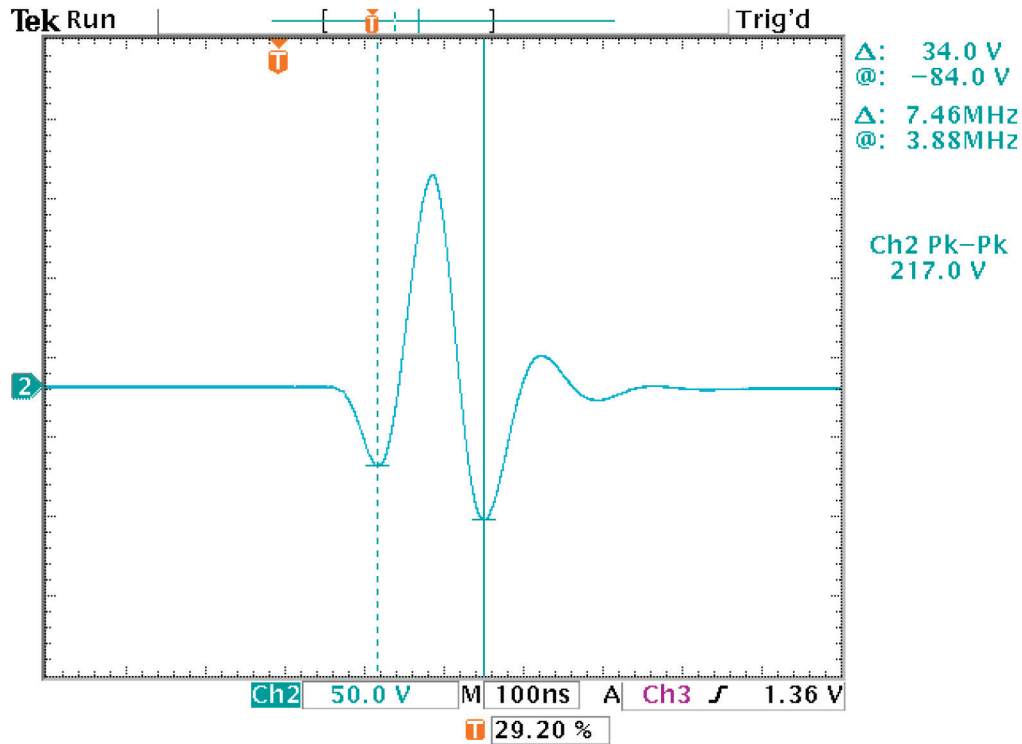

Figure 2: Output waveform of 16-sample/cycle of 7.46MHz DAC = 255,  $V_{pp} = 75V$ , 220pF//1.0kΩ load.

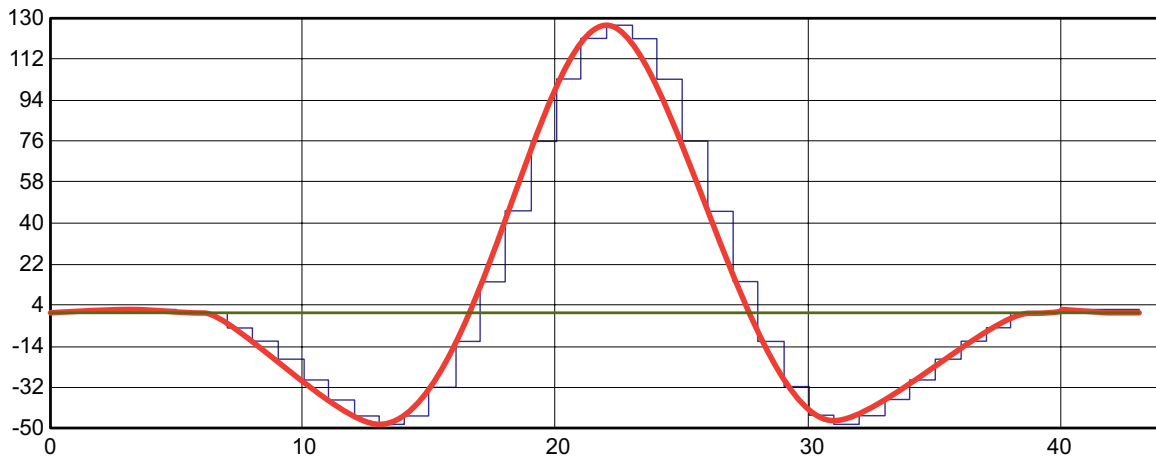

Figure 3: Example of Gauss-Sine waveform for LV1~LV15 SPI register values and transmit sequence.

The level-registers in MD2134 store 7 positive and 8 negative numbers and control the M[3:0] to transmit these levels. Use the sequence below and its reverse order. Including zeros, there are a total of 45 transmitted data samples.

LV = (0, 0, 2, 2, 2, 0, 0, -6, -12, -20, -29, -38, -45, -48, -45, -32, -12, 14, 45, 76, 103, 121, 127, . . .)

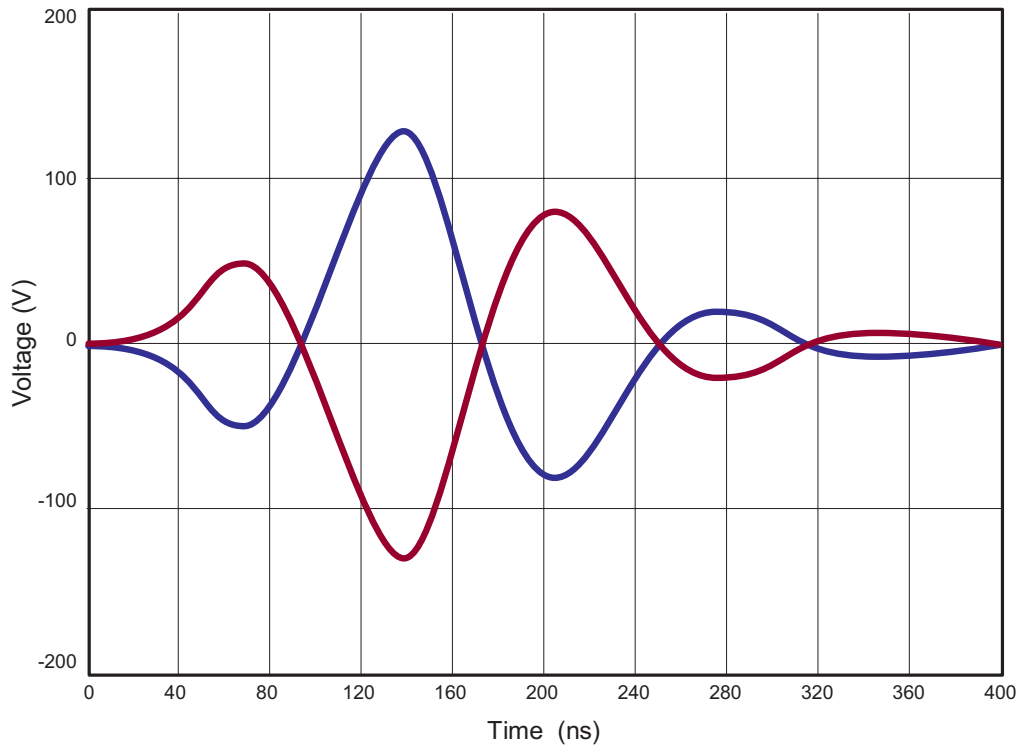

Figure 4: Output waveform and polarity reversed Gauss-Sine waveform at 16-sample/cycle of 7.46MHz DAC = 255,  $V_{pp} = 75V$ , 220pF//1.0k $\Omega$  load.

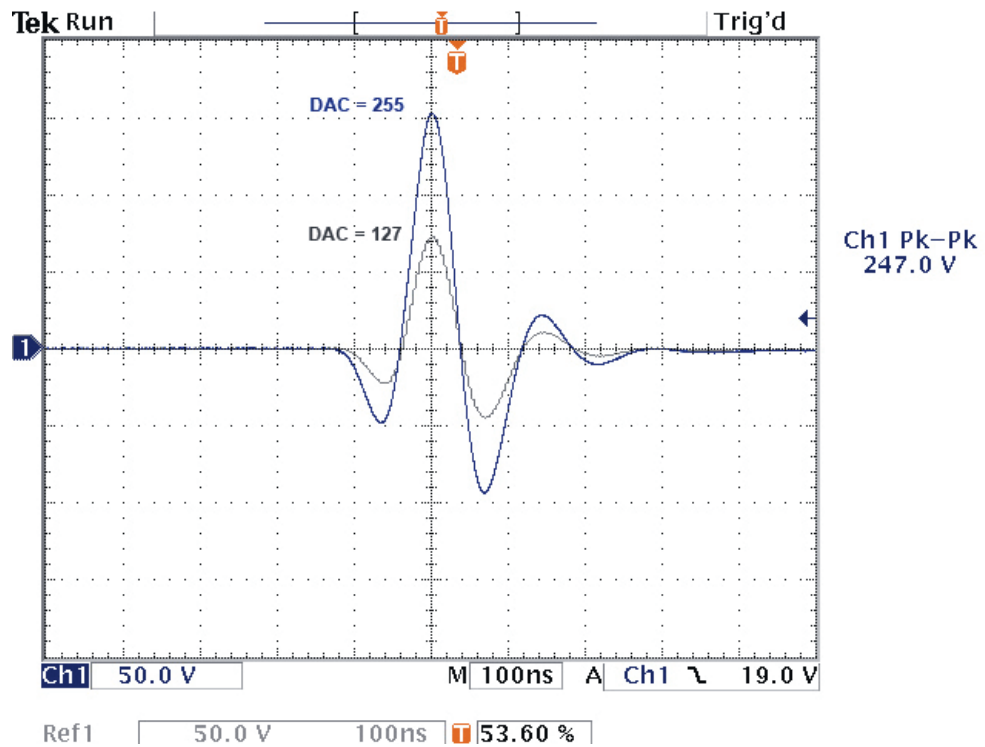

Figure 5: Gauss-Sine waveform at 16-sample/cycle of 7.46MHz DAC = 255,  $V_{pp} = 75V$ , 220pF//1.0k $\Omega$  load.

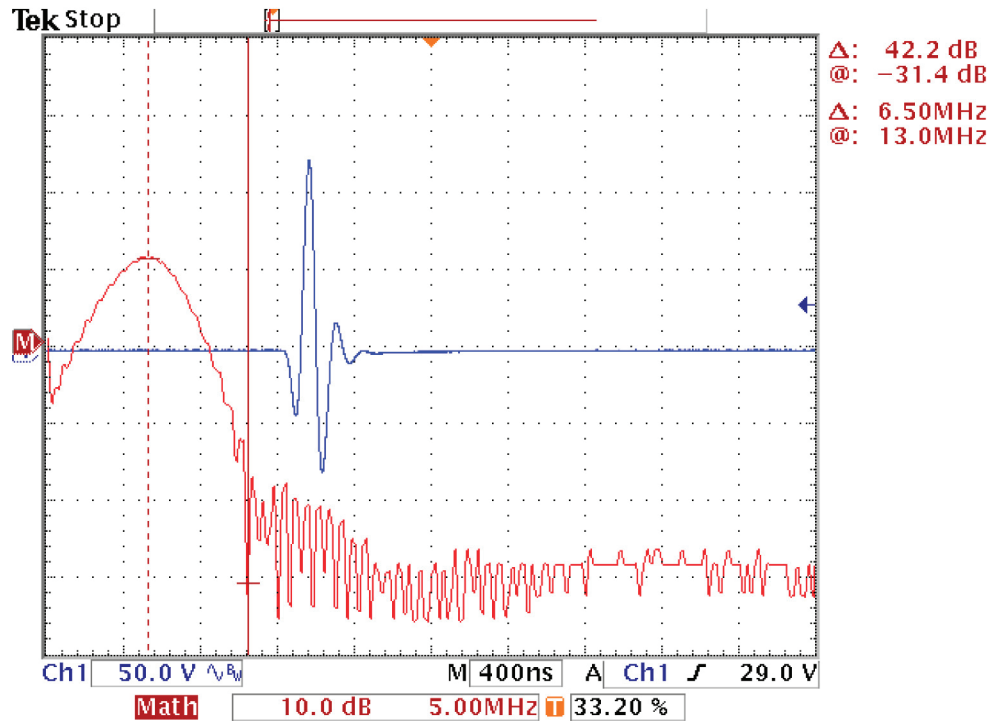

Figure 6: MD2134DB1 6.5MHz Gauss-Sine waveforms and frequency spectrum.

### Current Level Control Pin Description

Input Control Pin Name				PAM Current Level	Description
M3	M2	M1	M0		
0	0	0	0	LV0	PA & PB both off, zero current.
0	0	0	1	LV1	Select LV1 current magnitude to PA.
0	0	1	0	LV2	Select LV2 current magnitude to PA.
0	0	1	1	LV3	Select LV3 current magnitude to PA.
0	1	0	0	LV4	Select LV4 current magnitude to PA.
0	1	0	1	LV5	Select LV5 current magnitude to PA.
0	1	1	0	LV6	Select LV6 current magnitude to PA.
0	1	1	1	LV7	Select LV7 current magnitude to PA.
1	0	0	0	LV8	Select LV8 current magnitude to PB.
1	0	0	1	LV9	Select LV9 current magnitude to PB.
1	0	1	0	LV10	Select LV10 current magnitude to PB.
1	0	1	1	LV11	Select LV11 current magnitude to PB.
1	1	0	0	LV12	Select LV12 current magnitude to PB.
1	1	0	1	LV13	Select LV13 current magnitude to PB.
1	1	1	0	LV14	Select LV14 current magnitude to PB.
1	1	1	1	LV15	Select LV15 current magnitude to PB.

**Note:**

Turning on PA & PB simultaneously can cause over-current and permanent damage to the IC, high voltage MOSFETs, or to the transformer.



## Board Connector and Test Pin Description

CPLD Pin #	Signal Name	Description
U2, 3 - 15, 26, 35	VCC	CPLD logic power supply +3.3V
U2, 3 - 26	VLL	CPLD, VCCIO and MD2134 logic power supply +2.5V
U2, 3 - 4, 17, 25	GND	Logic power ground 0V
U2 - 2	WAV	Run or stop demo waveform phase
U2 - 3	FRE	Selecting frequency: 8,10 and 13.3MHz
U2 - 5	PHASE	Single step phase change, angle stepping:0, 7.5, 15...360
U2 - 6	AMPL	Single step amplitude change, DAC stepping: 15, 31...255
U2 - 7	ENA	Control MD2134 EN pin
U2 - 18	M1	Output signal to MD2134 M1
U2 - 19	M0	Output signal to MD2134 M0
U2 - 20	M3	Output signal to MD2134 M3
U2 - 21	M2	Output signal to MD2134 M2
U3 - 31	LED1	Output signal yellow, PH0 LED is on when phase = 0
U3 - 30	LED2	Output signal yellow, DAC LED is on when DAC = 127
U3 - 27	PWR	Output signal LED green, indicates +3.3V power supply on
U2, 3 - 10	TMS	Test mode select of JTAG
U2, 3 - 9	TDI	Test data in of JTAG, two CPLD in daisy chain
U2, 3 - 24	TDO	Test data out of JTAG, two CPLD in daisy chain
U2, 3 - 11	TCK	Test clock of JTAG
U2, 3 - 43	CLK	CPLD clock input
U2, 3 - 39	EXTRG	External trigger signal input to control waveform timing
U2, 3 - 12	EN	Output signal LED red, indicates MD2134 is enabled
U3 - 22	SDI	Output signal to MD2134 SDI
U3 - 16	SDO	Input signal from MD2134 SDO
U3 - 23	SCK	Output signal to MD2134 SCK
U3 - 14	CS	Output signal to MD2134 CS
U3 - 13	LD	Output signal to MD2134 LD
All remaining pins		NC or Reserved

JTAG Connector Pin #	Signal Name	Description
J6-1	TMS	Test Mode Select of CPLD.
J6-2	TDI	Test Data In of CPLD.
J6-3	TDO	Test Data Out of CPLD.
J6-4	TCK	Test Clock of CPLD.
J6-5	GND	Logic power supply ground 0V for programming only.
J6-6	VCC	Logic power supply +3.3V for programming only.

Signal and Jumper Pin #	Signal Name	Description
J1	EXCLK	External clock input when on-board oscillator is disabled, or output of the clock when it is enabled.
J2	OSC_EN	Jumper for on-board oscillator, short = disabled, open = enabled.
J3	EXTRG	External trigger signal input.
J4	Load JP	Jumper for on-board RC load to MD2134DB1 high voltage output and XDCR connector.
J5	XDCR	MD2134DB1 waveform output, for SMA-cable to oscilloscope, <b>high voltage!</b> 0 to +/-350V <sub>P-P</sub> max.

### Power Supply Connector

J7-1	VCC	+3.3V, MOSFET gate biasing and CPLD supply voltage with current limit from 120 to 150mA.
J7-2	GND	Ground reference, 0V.
J7-3	VDD	+5.0V MD2134 positive supply voltages with current limit to 50mA
J7-4	GND	Ground reference, 0V.
J7-5	VPP	+70 to 100V, the high voltage supply with current limit to 30mA.

### Voltage Supply Power-Up Sequence

Step	Signal Name	Description
1	V <sub>DD</sub>	+5.0, MD2134 positive supply voltages
2	V <sub>CC</sub>	+3.3V, MOSFET gate biasing and CPLD control logic supply voltage
3	V <sub>PP</sub>	+70V to 100V, the high voltage supply
4	EN Logic Active	Enable logic control, active-high signal to MD2134

### Voltage Supply Power-Down Sequence

1	EN Logic Active	Disable logic control, active-high signal to MD2134
2	V <sub>PP</sub>	+70V to 100V, the high voltage supply, off
3	V <sub>DD</sub>	+5.0V, MD2134 positive supply voltages with all input signals LOW, off
4	V <sub>CC</sub>	+3.3, CPLD control logic supply voltage with EN = 0, off

## MD2134DB1 Bill of Materials

Reference	Description	Manufacturer's Part Number	Manufacturer
C1 - C12, C16, C17, C20, C22 - C24, C27, C29 - C31, C35, C37 - C39	CAP .1 $\mu$ F 25V CERAMIC X7R 0603	ECJ-1VB1E104K	Panasonic
C5, C28	CAP CER 3300PF 10% 100V X7R 0603	06031C332KAT2A	AVX
C13, C14, C15, C21, C25, C26	CAP .027 $\mu$ F 50V CERAMIC X7R 0603	ECJ-1VB1H273K	Panasonic
C18, C36	CAP CER 1 $\mu$ F 100V X7R 20% 1210	C3225X7R2A105M	TDK
C19	CAP CERAMIC 220PF 200V NP0 0805	ECJ-2YC2D221J	Panasonic
C32, C33, C34	CAP 10 $\mu$ F 16V ELECT WT SMD	UWT1C100MCL1GB	Nichicon
D1, D4	LED THIN 585NM YEL DIFF 0805 SMD	SML-LXT0805YW-TR	Lumex
D2	LED THIN 635NM RED DIFF 0805 SMD	SML-LXT0805IW-TR	Lumex
D3	LED THIN 565NM GRN DIFF 0805 SMD	SML-LXT0805GW-TR	Lumex
D9	Diode Schottky, 100V, 1.0A, SMA	B1100-13	Diodes Inc.
D5 - D8	Diode Schottky, dual, 30V, SOT-363	BAT54DW-7	Diodes Inc.
M1	250V 3.0A dual depletion N-MOSFET, 5x5mm, DFN-8	DN2625DK6-G	Supertex Inc.
R1	RES 1.00k $\Omega$ 1/16W 1% 0603 SMD	ERJ-3EKF1001V	Panasonic
R2, R7	RES 49.9 $\Omega$ 1/16W 1% 0603 SMD	ERJ-3EKF49R9V	Panasonic
R3 - R6, R10, R14, R22 - R26	RES 200 $\Omega$ 1/16W 1% 0603 SMD	ERJ-3EKF2000V	Panasonic
R8, R15	RES 1.0 $\Omega$ 1W 1% 2512 SMD	ERJ-1TRQF1R0U	Panasonic
R9, R12	RES 100 $\Omega$ 1W 1% 2512 SMD	ERJ-1TNF1000U	Panasonic
R11, R27	PCB copper short	NA	NA
R13	RES 1k $\Omega$ 1W 1% 2512 SMD	ERJ-1TYF102U	Panasonic
R16	RES 49.9k $\Omega$ 1/16W 1% 0603 SMD	ERJ-3EKF4992V	Panasonic
R17, R18, R19, R20, R21	RES 33.2k $\Omega$ 1/16W 1% 0603 SMD	ERJ-3EKF3322V	Panasonic
R28	PCB copper short	NA	NA
T1	22 $\mu$ H, 1:1:1 wideband ultrasound pulse transformer	750340727	Würth Electronics
U1	IC ultrasound beamforming source driver 40-Lead QFN	MD2134K7-G	Supertex Inc.
U2, U3	IC CPLD, 72 MCELL, C-Temp, 44-VQFP	XC9572XL-5VQ44C	Xilinx
U4	IC precision reference micropower ref, SOT-23	LM4040DEM3-2.5	National
U5	IC voltage regulator, 1.5A, 2.5V, SOT-223	ADP3339AKC-2.5	ADI
X1	Oscillator clock, 160.000MHz, 3.3V, SMD	JITO-2-DC3AE-160	FOX Electronics

**Supertex inc.** does not recommend the use of its products in life support applications, and will not knowingly sell them for use in such applications unless it receives an adequate "product liability indemnification insurance agreement." **Supertex inc.** does not assume responsibility for use of devices described, and limits its liability to the replacement of the devices determined defective due to workmanship. No responsibility is assumed for possible omissions and inaccuracies. Circuitry and specifications are subject to change without notice. For the latest product specifications refer to the **Supertex inc.** (website: <http://www.supertex.com>)

Компания «Океан Электроники» предлагает заключение долгосрочных отношений при поставках импортных электронных компонентов на взаимовыгодных условиях!

Наши преимущества:

- Поставка оригинальных импортных электронных компонентов напрямую с производств Америки, Европы и Азии, а так же с крупнейших складов мира;
- Широкая линейка поставок активных и пассивных импортных электронных компонентов (более 30 млн. наименований);
- Поставка сложных, дефицитных, либо снятых с производства позиций;
- Оперативные сроки поставки под заказ (от 5 рабочих дней);
- Экспресс доставка в любую точку России;
- Помощь Конструкторского Отдела и консультации квалифицированных инженеров;
- Техническая поддержка проекта, помощь в подборе аналогов, поставка прототипов;
- Поставка электронных компонентов под контролем ВП;
- Система менеджмента качества сертифицирована по Международному стандарту ISO 9001;
- При необходимости вся продукция военного и аэрокосмического назначения проходит испытания и сертификацию в лаборатории (по согласованию с заказчиком);
- Поставка специализированных компонентов военного и аэрокосмического уровня качества (Xilinx, Altera, Analog Devices, Intersil, Interpoint, Microsemi, Actel, Aeroflex, Peregrine, VPT, Syfer, Eurofarad, Texas Instruments, MS Kennedy, Miteq, Cobham, E2V, MA-COM, Hittite, Mini-Circuits, General Dynamics и др.);

Компания «Океан Электроники» является официальным дистрибьютором и эксклюзивным представителем в России одного из крупнейших производителей разъемов военного и аэрокосмического назначения «JONHON», а так же официальным дистрибьютором и эксклюзивным представителем в России производителя высокотехнологичных и надежных решений для передачи СВЧ сигналов «FORSTAR».



## JONHON

«JONHON» (основан в 1970 г.)

Разъемы специального, военного и аэрокосмического назначения:

(Применяются в военной, авиационной, аэрокосмической, морской, железнодорожной, горно- и нефтедобывающей отраслях промышленности)

«FORSTAR» (основан в 1998 г.)

ВЧ соединители, коаксиальные кабели, кабельные сборки и микроволновые компоненты:

(Применяются в телекоммуникациях гражданского и специального назначения, в средствах связи, РЛС, а так же военной, авиационной и аэрокосмической отраслях промышленности).



Телефон: 8 (812) 309-75-97 (многоканальный)

Факс: 8 (812) 320-03-32

Электронная почта: [ocean@oceanchips.ru](mailto:ocean@oceanchips.ru)

Web: <http://oceanchips.ru/>

Адрес: 198099, г. Санкт-Петербург, ул. Калинина, д. 2, корп. 4, лит. А