

Monolithic CMOS Analog Multiplexers

General Description

Maxim's DG508A and DG509A are monolithic CMOS analog multiplexers (muxes): the DG508A is a single 8-channel (1-of-8) mux, and the DG509A is a differential 4-channel (2-of-8) mux.

Both devices guarantee break-before-make switching. Maxim guarantees these muxes will not latch up if the power supplies are turned off with the input signals still present. Maxim also guarantees continuous operation when these devices are powered by supplies ranging from $\pm 4.5\text{V}$ to $\pm 18\text{V}$.

The DG508A/DG509A are plug-in upgrades for the industry-standard DG508A/DG509A, respectively. Maxim's parts have faster enable switching times and significantly lower leakage currents. The DG508A/DG509A also consume significantly lower power, making them ideal for portable equipment.

Applications

Control Systems
Data Logging Systems
Aircraft Heads-Up Displays
Data-Acquisition Systems
Signal Routing

Typical Operating Circuits

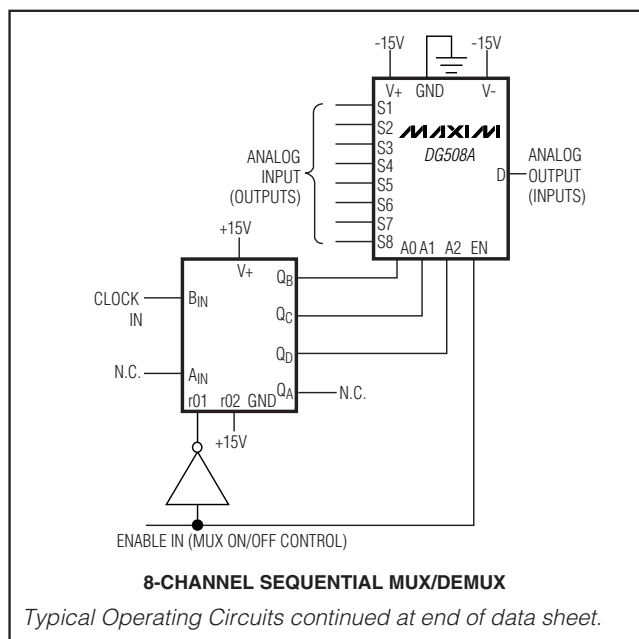

Features

- ◆ Improved Second Source
- ◆ Operate from $\pm 4.5\text{V}$ to $\pm 18\text{V}$ Supplies
- ◆ Symmetrical, Bidirectional Operation
- ◆ Logic and Enable Inputs, TTL and CMOS Compatible
- ◆ Latchup-Proof Construction
- ◆ Monolithic, Low-Power CMOS Design

Ordering Information

PART	TEMP RANGE	PIN-PACKAGE
DG508ACJ	0°C to +70°C	16 Plastic DIP
DG508ACWE	0°C to +70°C	16 Wide SO
DG508AC/D	0°C to +70°C	Dice*
DG508ABK	-20°C to +85°C	16 CERDIP
DG508ADJ	-40°C to +85°C	16 Plastic DIP
DG508ADY	-40°C to +85°C	16 Narrow SO
DG508AEWE	-40°C to +85°C	16 Wide SO
DG508AAK	-55°C to +125°C	16 CERDIP
DG508AMY/PR	-55°C to +125°C	16 Narrow SO
DG509ACJ	0°C to +70°C	16 Plastic DIP
DG509ACWE	0°C to +70°C	16 Wide SO
DG509AC/D	0°C to +70°C	Dice*
DG509ABK	-20°C to +85°C	16 CERDIP
DG509ADJ	-40°C to +85°C	16 Plastic DIP
DG509ADY	-40°C to +85°C	16 Narrow SO
DG509AEWE	-40°C to +85°C	16 Wide SO
DG509AAK	-55°C to +125°C	16 CERDIP
DG509AMY/PR	-55°C to +125°C	16 Narrow SO

Devices are available in a lead(Pb)-free/RoHS-compliant package (except CERDIP). Specify lead-free by adding a plus (+) to the part number when ordering.

*Contact factory for dice specifications.

Monolithic CMOS Analog Multiplexers

ABSOLUTE MAXIMUM RATINGS

Voltage Referenced to V-

V+	+44V
GND	+25V
Digital Inputs, V _S and V _D (Note 1)	-2V to (V+ + 2V) or 20mA, whichever occurs first
Current (any terminal, except S or D)	30mA
Continuous Current, S or D	20mA
Peak Current, S or D (pulsed at 1ms, 10% duty cycle max) ..	40mA
Continuous Power Dissipation (T _A = +70°C)	
Plastic DIP (derate 10.53mW/°C above +70°C)	842mW
Narrow SO (derate 8.70mW/°C above +70°C)	696mW
Wide SO (derate 9.52mW/°C above +70°C)	762mW
CERDIP (derate 10.00mW/°C above +70°C)	800mW

Operating Temperature Ranges:

DG50_ACJ/CWE	0°C to +70°C
DG50_ABK	-20°C to +85°C
DG50_ADJ/DY/EWE	-40°C to +85°C
DG50_AAK/MY	-55°C to +125°C
Storage Temperature Range	-65°C to +150°C
Lead Temperature (soldering, 10s)	+300°C
Soldering Temperature (reflow)	
PDIP, Wide SO, Narrow SO, CERDIP containing lead(Pb) ..	+240°C
PDIP, Wide SO, Narrow SO lead(Pb)-free	+260°C

Note 1: Signals on S₋ or D₋ exceeding V+ or V- are clamped by internal diodes. Limit forward-diode current to maximum current ratings

Stresses beyond those listed under "Absolute Maximum Ratings" may cause permanent damage to the device. These are stress ratings only, and functional operation of the device at these or any other conditions beyond those indicated in the operational sections of the specifications is not implied. Exposure to absolute maximum rating conditions for extended periods may affect device reliability.

ELECTRICAL CHARACTERISTICS

(V+ = 15V, V- = -15V, V_{GND} = 0V, T_A = +25°C, unless otherwise noted.)

PARAMETER	SYMBOL	CONDITIONS	DG508AA/M DG509AA/M			DG508AD/E/B/C DG509AD/E/B/C			UNITS
			MIN	TYP	MAX	MIN	TYP	MAX	
SWITCH									
Analog Signal	V _{ANALOG}		-15		+15	-15		+15	V
Drain-Source On-Resistance	R _{DS(ON)}	Sequence each switch on, V _{A_L} = 0.8V, V _{A_H} = 2.4V (Note 4)	V _D = 10V, I _S = -200μA		170	400	170	450	Ω
			V _D = -10V, I _S = 200μA		130	400	130	450	
Greatest Change in Drain-Source On-Resistance Between Channels	ΔR _{DS(ON)}	$\Delta R_{DS(ON)} = \left(\frac{R_{DS(ON) \max} - R_{DS(ON) \min}}{R_{DS(ON)}} \right)$			6		6		%
Source Off-Leakage Current	I _{S(OFF)}	V _{EN} = 0V	V _S = 10V, V _D = -10V		0.002	0.5	0.002	1	nA
			V _S = -10V, V _D = 10V		-0.5	-0.005	-1	-0.005	
Drain Off-Leakage Current	DG508A	V _{EN} = 0V	V _D = 10V, V _S = -10V		0.01	2	0.01	5	nA
			V _D = -10V, V _S = 10V		-2	-0.015	-5	-0.015	
	DG509A		V _D = 10V, V _S = -10V		0.005	2	0.005	5	
			V _D = -10V, V _S = 10V		-2	-0.008	-5	-0.008	
Drain On-Leakage Current	DG508A	Sequence each switch on, V _{A_L} = 0.8V V _{A_H} = 2.4V (Note 2)	V _{S(all)} = V _D = 10V		0.015	2	0.015	5	nA
			V _{S(all)} = V _D = -10V		-2	-0.03	-5	-0.03	
	DG509A		V _{S(all)} = V _D = 10V		0.007	2	0.007	5	
			V _{S(all)} = V _D = -10V		-2	-0.015	-5	-0.015	

Monolithic CMOS Analog Multiplexers

DG508A/DG509A

ELECTRICAL CHARACTERISTICS (continued)

(V+ = 15V, V- = -15V, VGND = 0V, TA = +25°C, unless otherwise noted.)

PARAMETER	SYMBOL	CONDITIONS	DG508AA/M DG509AA/M			DG508AD/E/B/C DG509AD/E/B/C			UNITS
			MIN	TYP	MAX	MIN	TYP	MAX	
LOGIC INPUT									
Logic Input Current, Input Voltage High	IAH	VA_ = 2.4V		-10	-	10	-0.002	μA	
		VA_ = 15V		0.006	10	0.006	10		
Logic Input Current, Input Voltage Low	IAL	All VA_ = 0V	VEN = 2.4V		-10	-	10	-0.002	μA
			VEN = 0V		-10	-	-10	-0.002	
DYNAMIC									
Multiplexer Switching	ttransition	Figure 1		0.6	1.0	0.6	1.0	μs	
Break-Before-Make Interval	tOPEN	Figure 3		0.2		0.2		μs	
Enable Turn-On Time	tON(EN)	Figure 2		0.4	1.0	0.4	1.5	μs	
Enable Turn-Off Time	tOFF(EN)	Figure 2		0.2	0.7	0.2	1.0	μs	
Off-Isolation	OIRR	VEN = 0V, RL = 1kΩ, CL = 15pF, VS = 7VRMS f = 500kHz (Note 3)		68		68		dB	
Source Off-Capacitance	CS(OFF)	VS = 0V, VEN = 0V, f = 140kHz		5		5		pF	
Drain Off- Capacitance	IDG508A	CD(OFF)	VS = 0V, VEN = 0V, f = 140kHz		25		25	pF	
	DGS09A				12		12		
SUPPLY									
Positive Supply Current	I+	VEN = 2.4V, all VA_ = 0V or 2.4V		0.02	0.2	0.02	0.2	mA	
Negative Supply Current	I-	VEN = 2.4V, all VA_ = 0V or 2.4V		-0.1	-0.01	-0.1	-0.01	mA	
Positive Supply Current in Standby	I+	VEN = 0V, all VA_ = 0V or 2.4V		0.02	0.2	0.02	0.2	mA	
Negative Supply Current in Standby	I-	VEN = 0V, all VA_ = 0V or 2.4V		-0.1	-0.01	-0.1	-0.01	mA	
Power-Supply Range for Continuous Operation	V-, V+	(Notes 4, 5)		±4.5	±18.0	±4.5	±18.0	V	

Monolithic CMOS Analog Multiplexers

ELECTRICAL CHARACTERISTICS

(V₊ = 15V, V_{GND} = 0V, T_A = T_{MIN} to T_{MAX}, unless otherwise noted.)

PARAMETER	SYMBOL	CONDITIONS	DG508AA/M DG509AA/M			DG508AD/E/B/C DG509AD/E/B/C			UNITS	
			MIN	TYP	MAX	MIN	TYP	MAX		
SWITCH										
Analog Signal Range	V _{ANALOG}		-15	+15		-15	+15		V	
Drain-Source On-Resistance	R _{DS(ON)}	Sequence each switch on, V _{A_L} = 0.8V, V _{A_H} = 2.4V	V _D = 10V, I _S = -200μA		500		550		Ω	
			V _D = -10V, I _S = 200μA		500		550			
Source Off-Leakage Current	I _{S(OFF)}	V _{EN} = 0V	V _S = 10V, V _D = -10V V _S = -10V, V _D = -10V		+50		+50		nA	
				-50		-50				
Drain Off-Leakage Current	DG508A DG509A	I _{D(OFF)}	V _{EN} = 0V	V _D = 10V, V _S = -10V		+200		+100	nA	
				V _D = -10V, V _S = -10V	-200		-200			
				V _D = 10V, V _S = -10V		+200		+100		
				V _D = -10V, V _S = -10V	-100		-100			
Drain On-Leakage Current	DG508A DG509A	I _{D(ON)}	Sequence each switch on, V _{A_L} = 0.8V, V _{A_H} = 2.4V (Note 2)	V _{S(all)} = V _D = 10V		+200		+100	nA	
				V _{S(all)} = V _D = -10V	-200		-100			
				V _{S(all)} = V _D = 10V		+100		+100		
				V _{S(all)} = V _D = -10V	-100		-100			
LOGIC INPUT										
Logic Input Current, Input Voltage High	I _{AH}	V _{A_} = 2.4V		-30		-30		μA		
		V _{A_} = 15V		+30		+30				
Logic Input Current, Input Voltage Low	I _{AL}	All V _{A_} = 0V	V _{EN} = 2.4V	-30		-30		μA		
			V _{EN} = 0V	-30		-30				

Note 2: I_{D(ON)} is leakage from driver into on switch.

Note 3: Off-isolation = 20log $\frac{|V_S|}{|V_D|}$

V_S = input to off switch,
V_D = output due to V_S.

Note 4: Electrical characteristics (such as on-resistance) change when power supplies other than ±15V are used.

Note 5: For designs requiring single 5V or dual ±5V operation, refer to Maxim's improved MAX338 and MAX339. Minimum operating voltage for DG508ADY/MY and DG509ADY/MY is ±9V.

Monolithic CMOS Analog Multiplexers

DG508A/DG509A

Pin Configurations



Pin Descriptions

PIN		NAME	FUNCTION
DG508A DIP/SO	DG509A DIP/SO		
1, 15, 16	—	A0, A2, A1	Address Input
—	1, 16	A0, A1	Address Input
2	2	EN	Enable
3	3	V-	Negative-Supply Voltage Input
4-7	—	S1-S4	Analog Inputs, Bidirectional
—	4-7	S1A-S4A	Analog Inputs, Bidirectional
8	—	D	Analog Outputs, Bidirectional
—	8, 9	DA, DB	Analog Outputs, Bidirectional
9-12	—	S8-S5	Analog Inputs, Bidirectional
—	10-13	S4B-S1B	Analog Inputs, Bidirectional
13	14	V+	Positive-Supply Voltage Input
14	15	GND	Ground

Functional Diagrams

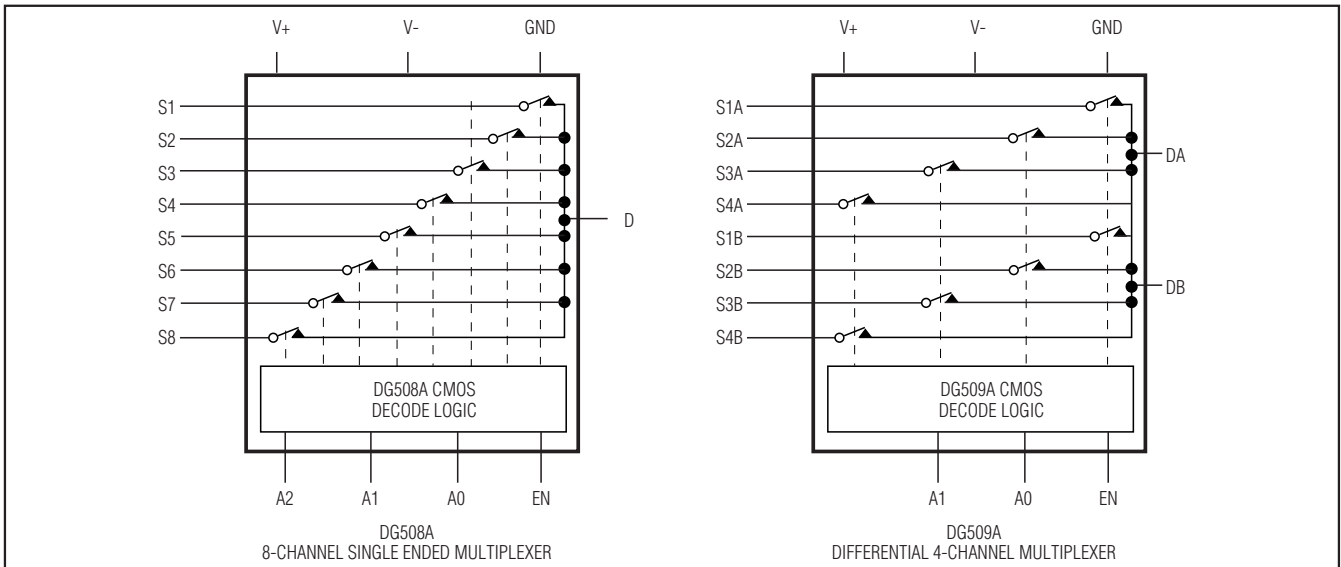

Monolithic CMOS Analog Multiplexers

DG508A/DG509A

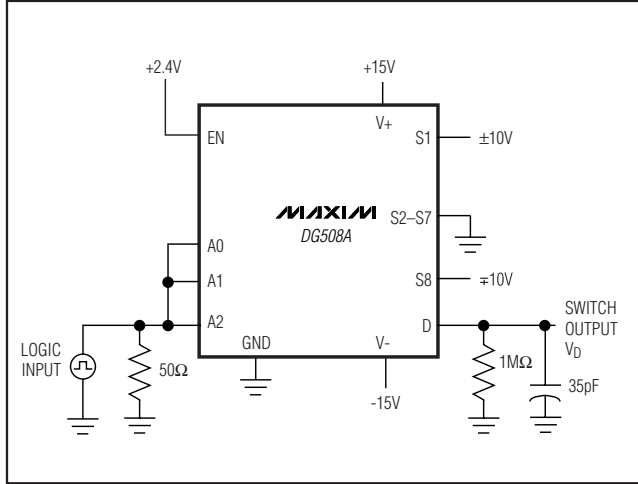

Figure 1a. Switching-Time Test Circuit

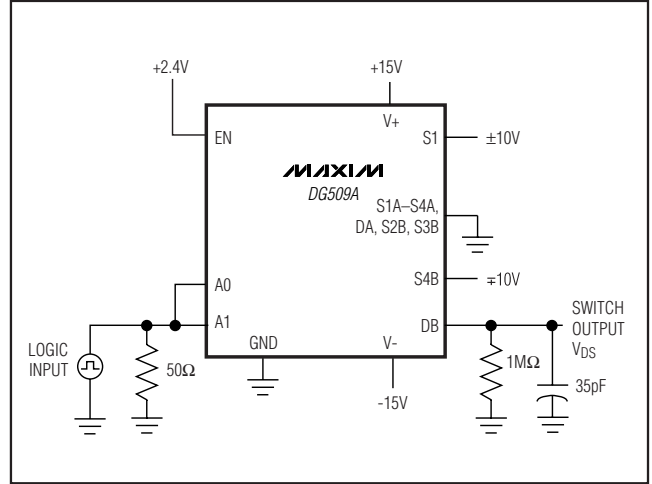

Figure 1b. Switching-Time Test Circuit

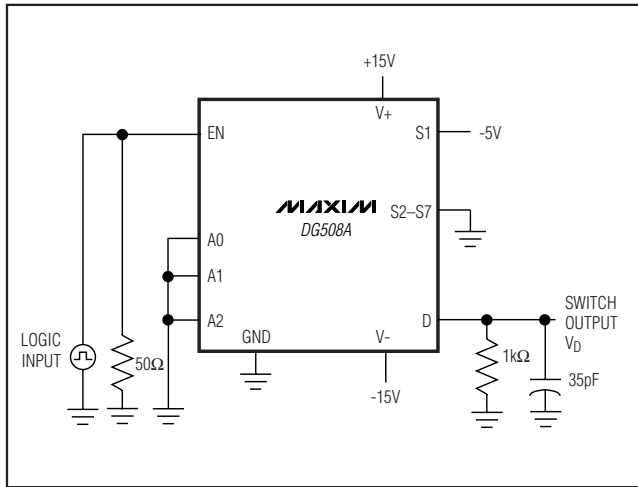

Figure 2a. DG508A Enable-Time Test Circuit



Figure 2b. DG509A Enable-Time Test Circuit

Monolithic CMOS Analog Multiplexers

DG508A/DG509A

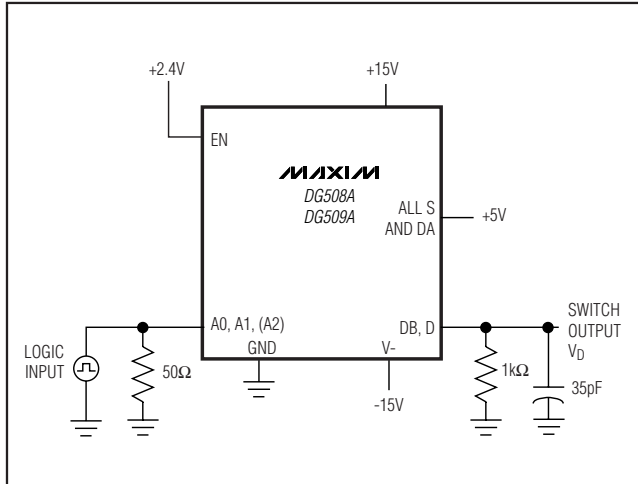

Figure 3. Break-Before-Make Test Circuit

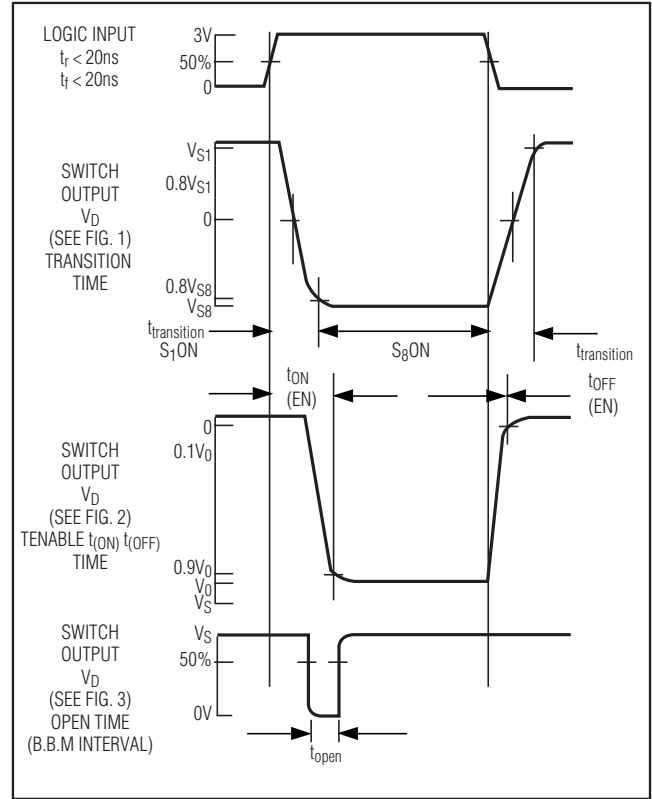

Figure 4. Timing Diagram for Figures 1, 2, and 3

Table 1a. DG508A Truth Table

A2	A1	A0	EN	ON SWITCH
X	X	X	0	NONE
0	0	0	1	1
0	0	1	1	2
0	1	0	1	3
0	1	1	1	4
1	0	0	1	5
1	0	1	1	6
1	1	0	1	7
1	1	1	1	8

X = Don't care.

Table 1b. DG509A Truth Table

A1	A0	EN	ON SWITCH
X	X	0	NONE
0	0	1	1
0	1	1	2
1	0	1	3
1	1	1	4

X = Don't care.

Monolithic CMOS Analog Multiplexers

Typical Operating Circuits (continued)

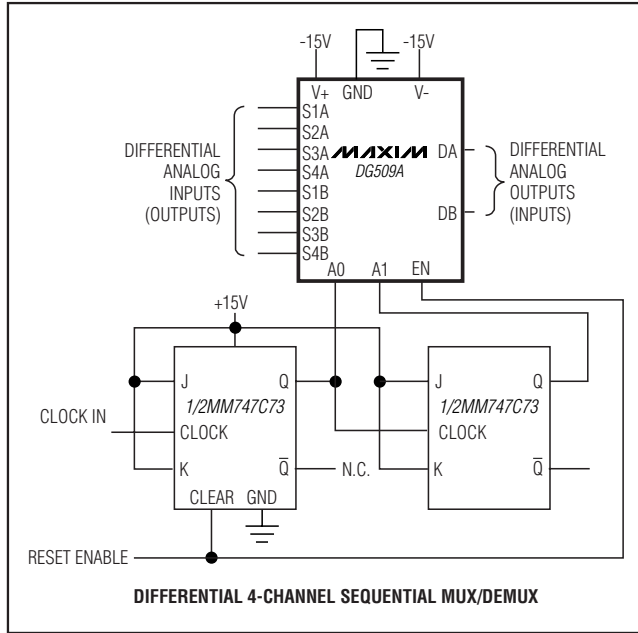

Package Information

For the latest package outline information and land patterns, go to www.maxim-ic.com/packages. Note that a "+", "#", or "-" in the package code indicates RoHS status only. Package drawings may show a different suffix character, but the drawing pertains to the package regardless of RoHS status.

PACKAGE TYPE	PACKAGE CODE	DOCUMENT NO.
16 Plastic DIP	P16-1	21-0043
16 Wide SO	W16-2	21-0042
16 Narrow SO	S16-5	21-0041
16 CERDIP	J16-3	21-0045

Monolithic CMOS Analog Multiplexers

Revision History

REVISION NUMBER	REVISION DATE	DESCRIPTION	PAGES CHANGED
4	5/10	Updated the "Drain-Source On-Resistance" parameter for both the $T_A = +25^\circ\text{C}$ and $T_A = T_{\text{MIN}}$ to T_{MAX} conditions.	2, 4
		Deleted the QFN package from the <i>Ordering Information</i> , <i>Absolute Maximum Ratings</i> , <i>Pin Configurations</i> , <i>Pin Descriptions</i> , and <i>Package Information</i> sections.	1, 2, 5, 8
		Added the DG508AMY/PR and DG509AMY/PR parts to the <i>Ordering Information</i> table.	1

DG508A/DG509A

Maxim cannot assume responsibility for use of any circuitry other than circuitry entirely embodied in a Maxim product. No circuit patent licenses are implied. Maxim reserves the right to change the circuitry and specifications without notice at any time.

Maxim Integrated Products, 120 San Gabriel Drive, Sunnyvale, CA 94086 408-737-7600 _____ 9

Компания «Океан Электроники» предлагает заключение долгосрочных отношений при поставках импортных электронных компонентов на взаимовыгодных условиях!

Наши преимущества:

- Поставка оригинальных импортных электронных компонентов напрямую с производств Америки, Европы и Азии, а так же с крупнейших складов мира;
- Широкая линейка поставок активных и пассивных импортных электронных компонентов (более 30 млн. наименований);
- Поставка сложных, дефицитных, либо снятых с производства позиций;
- Оперативные сроки поставки под заказ (от 5 рабочих дней);
- Экспресс доставка в любую точку России;
- Помощь Конструкторского Отдела и консультации квалифицированных инженеров;
- Техническая поддержка проекта, помощь в подборе аналогов, поставка прототипов;
- Поставка электронных компонентов под контролем ВП;
- Система менеджмента качества сертифицирована по Международному стандарту ISO 9001;
- При необходимости вся продукция военного и аэрокосмического назначения проходит испытания и сертификацию в лаборатории (по согласованию с заказчиком);
- Поставка специализированных компонентов военного и аэрокосмического уровня качества (Xilinx, Altera, Analog Devices, Intersil, Interpoint, Microsemi, Actel, Aeroflex, Peregrine, VPT, Syfer, Eurofarad, Texas Instruments, MS Kennedy, Miteq, Cobham, E2V, MA-COM, Hittite, Mini-Circuits, General Dynamics и др.);

Компания «Океан Электроники» является официальным дистрибьютором и эксклюзивным представителем в России одного из крупнейших производителей разъемов военного и аэрокосмического назначения «JONHON», а так же официальным дистрибьютором и эксклюзивным представителем в России производителя высокотехнологичных и надежных решений для передачи СВЧ сигналов «FORSTAR».



JONHON

«JONHON» (основан в 1970 г.)

Разъемы специального, военного и аэрокосмического назначения:

(Применяются в военной, авиационной, аэрокосмической, морской, железнодорожной, горно- и нефтедобывающей отраслях промышленности)

«FORSTAR» (основан в 1998 г.)

ВЧ соединители, коаксиальные кабели, кабельные сборки и микроволновые компоненты:

(Применяются в телекоммуникациях гражданского и специального назначения, в средствах связи, РЛС, а так же военной, авиационной и аэрокосмической отраслях промышленности).



Телефон: 8 (812) 309-75-97 (многоканальный)

Факс: 8 (812) 320-03-32

Электронная почта: ocean@oceanchips.ru

Web: <http://oceanchips.ru/>

Адрес: 198099, г. Санкт-Петербург, ул. Калинина, д. 2, корп. 4, лит. А