

700DNC40-12-xG DC/DC CONVERTER



The Bel Power Solutions **700DNC40-12-xG** is a 4 kW DC/DC Converter that creates DC voltages in hybrid and electric vehicles necessary to power low voltage accessories.

Liquid or convection cooled DC/DC converter operates at input voltages from 400 to 800 VDC and power range up to 4000 W/3300 W (liquid/convection cooled model).

Key Features & Benefits

- Very high efficiency up to 93%
- Input voltage range: 400-800 VDC
- Up to 4 kW power
- Full galvanic isolation between input and output
- CAN bus serial interface
- E-MARK E12*10R00-10R05*13669
- Adjustable output voltage
- Over temperature, output overvoltage and overcurrent protection, input and output reverse polarity protection
- Liquid or convection cooled models available
- Protection degree IP65 and IP67

North America
+1.866.513.2839

Asia-Pacific
+86.755.29885888

Europe, Middle East
+353 61 225 977

700DNC40-12-xG

Model Selection

MODEL	DESCRIPTION
700DNC40-12-8G	Liquid cooled model
700DNC40-12-CG	Convection cooled model
700DNC40-CON-KIT-8G	Mating connectors kit – Signal connector housing and pins, HV connector assembled with 3 m cable
700DNC40-CON-KIT-9G	Mating connectors kit - housing and pins

TECHNICAL DATA

Input

PARAMETER	DESCRIPTION / CONDITION	MIN	NOM	MAX	UNIT
Input Voltage		400	700	800	VDC
Input Current				11	ADC
Efficiency	@ Vin = 700 VDC, Vo = 14.4 V, I _{nom} = 229 A	92			%
Input Line Interruption	Converter shutdown			390	VDC
Input Capacitance			35		μF
Inrush Current	External pre-charging circuit required				

Output

PARAMETER	DESCRIPTION / CONDITION	MIN	NOM	MAX	UNIT
Output Voltage	Vo to be trimmed via CAN BUS, 10 bit resolution	9	14.4	16	VDC
Output Current	@ 14.4 VDC Liquid cooled model Convection cooled model		278 229		ADC
Output Power	Liquid cooled model Convection cooled model			4000 3300	W
Line Regulation	V _{inmin} - V _{inmax} , @ 139 A, T _{coolant} = 70°C	- 0.1		+ 0.1	VDC
Output Voltage Set Point	@ 139 A, T _{coolant} = 25°C	14.35	14.4	14.45	VDC
Thermal Drift		-0.05		+0.05	%/°C
Periodic and Random Deviation	@ 14.4 VDC / Nominal load (Differential Mode 20 MHz) CAN high / low (Differential Mode 20 MHz)			280 * 300 *	mVp-p
Transient Response	Load step 1: 10 to 50 % and back Load step 2: 50 to 100 % and back Voltage over/under shoot: Response time within 1 % of VoSET:	-1000		+1000 1000	mV μs
Turn-on Overshoot	V _{onom} , <100 ms			5	%
Redundant Parallel Operation	Up to 4 converters operating in parallel			16	kW
Remote Sense	Cable Drop (V) @ Maximum Load			0.5	V
Turn-On Delay	Rise time (Cext = 0 μF) Power-on-delay (From applying DC input voltage to Vo = 90 %) Power-on-time from PS_WAKE UP (From PS_WAKE UP ON to Vo = 90% of nom)			200 1 3	ms s s
Turn-Off Timing	PS_WAKEUP delay; (monotonic Vo fall)	0		100	ms
Capacitive Load	@ 14.4 VDC		0	10000	μF

* With external capacitors 47μF (Electrolytic cap) & 1μF (X7R Ceramic cap) connected to measuring point.

700DNC40-12-xG

Protection

PARAMETER	DESCRIPTION / CONDITION	MIN	NOM	MAX	UNIT
Output Over-Current Protection	Constant current Liquid cooled model Convection cooled model		285 235		A
Output Over-Voltage Protection	Latch type, max. OV duration 1 ms	17		18	V
Output Under-Voltage Protection	Max. UV duration 1 s, than hiccup	6		8	V
Over-Temperature Protection	Converter shutdown Liquid cooled model Convection cooled model	80 50			°C
Input and Output Reverse Polarity Protection	Protective elements connected in series				
Input Fuse Protection	DC Input: internal primary fuse, safety approved		20		A
Input Low Line Protection	Turn ON threshold Turn OFF threshold	390 370	400 380	410 390	VDC
Input Overvoltage Protection	Recovery: Vin re-cycling or PS_WAKEUP	810		850	V

Interface & Control Signals

PARAMETER	DESCRIPTION / CONDITION	
CAN BUS SAE J1939	250 kBit/s or 500 kBit/s available	
Remote sense signals	Sense positive (+12 V SENSE) Sense negative (-12 V SENSE)	0.5 V compensation
Address bits	Internally pulled up to LOGIC HIGH (3.3V 100kohm)	Adr. 0 Adr. 1
PS_WAKEUP	Logic input signal	LV BAT VOLTAGE
HVIL function	HVIL pin shorted internally	Part of HV connector
CAN_SPEED	CAN speed selection Internally pulled up to LOGIC HIGH (3.3V 100kohm)	Logic Low – 250kBit/s Logic High – 500kBit/s

Safety, Regulatory and EMC Specifications

PARAMETER	DESCRIPTION / CONDITION	CRITERION
Safety certification	Report number: E12*10R00-10R05*13669	E-MARK
Insulation	Basic: 3000 VDC	Input-to-Protective Earth
	Basic: 3000 VDC	Input-to-Output
Radiated Emission	UN ECE R10 4th Edition	ESA level
Electrostatic Discharge	IEC 61000-4-2	Performance Criterion B
Radiated Electromagnetic Field	IEC 61000-4-3 (10 V/m), SAE J1113/21(100V/m)	Performance Criterion B Class B
Electrical Fast Transient	IEC 61000-4-4, Level 2 (+/-2 kV, 2.5 kHz) ISO 7637-2; ISO 7637-3, ISO 16750-2	Performance Criterion B
RF Conducted Immunity	Level 3 (10 V, 0.15...80 MHz, AM 80%, 1kHz)	Performance Criterion A
RF Disturbances Immunity	SAE J1113-41 ISO11452-4 (1-400 MHz, 60 mA)	Class A Class B

Environmental Specifications

PARAMETER	DESCRIPTION / CONDITION	MIN	NOM	MAX	UNIT
Altitude	Operating: 62 kPa absolute pressure Non-Operating: 18.6 kPa absolute pressure			3600 12200	m
Operating Temperature	Liquid cooled model: Convection cooled model:	T_coolant with no derating T_amb @ full load, no power derating T_amb with no power derating	-40 -40 -40	+70 +85 +45	°C
Storage Temperature		-40		+95	°C
Humidity	SAE J1455				
Shock	SAE J1455				
Vibration	SAE J1455, MIL-STD-202G				

+353 61 225 977
tech.support@psbel.com
belpowersolutions.com

700DNC40-12-xG

Connectors

PARAMETER	DESCRIPTION / CONDITION	MANUFACTURER	MPN
Input Connector (IN)	High voltage connector with HVIL function	TYCO	2141272-1; KEY A
Output Connector (OUT)	Male dual terminal thread M8		
CAN BUS and Signal Interface (CTRL)	Panel mounted	TYCO	776276-1

Cooling Specification

PARAMETER	DESCRIPTION / CONDITION
Maximum Inlet Coolant Temperature	+70°C
Coolant Medium/Mixture	50/50 Propylene or Ethylene Glycol/Water
Min Coolant Flow	0.0208l/s (0.33GPM)
Max. coolant pressure	20psi
Max. pressure drop	1psi

Signal Connector Pin Description

Signal Connector

Output Connector

Input Connector

PIN	SIGNAL DESCRIPTION
1	PS_WAKEUP
2	ADR0
3	ADR1
4	CAN_SPEED
5	CAN_H
6	CAN_L
7	+SENSE
8	-SENSE

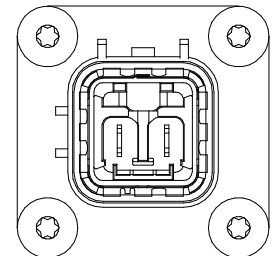
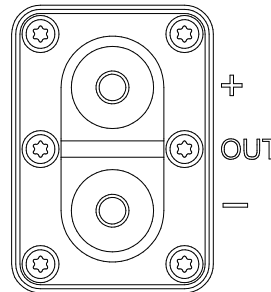
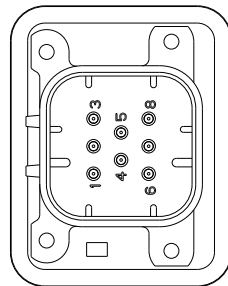

Mechanical Specifications

PARAMETER	LIQUID COOLED MODEL	CONVECTION COOLED MODEL
Dimensions (W x H x D)	270 x 113.3 x 343 mm	350 x 187.7 x 343 mm
Weight	11 kg	22 kg
Enclosure	IP65 and IP67	

700DNC40-12-xG

Mechanical Drawings - Liquid Cooled Model

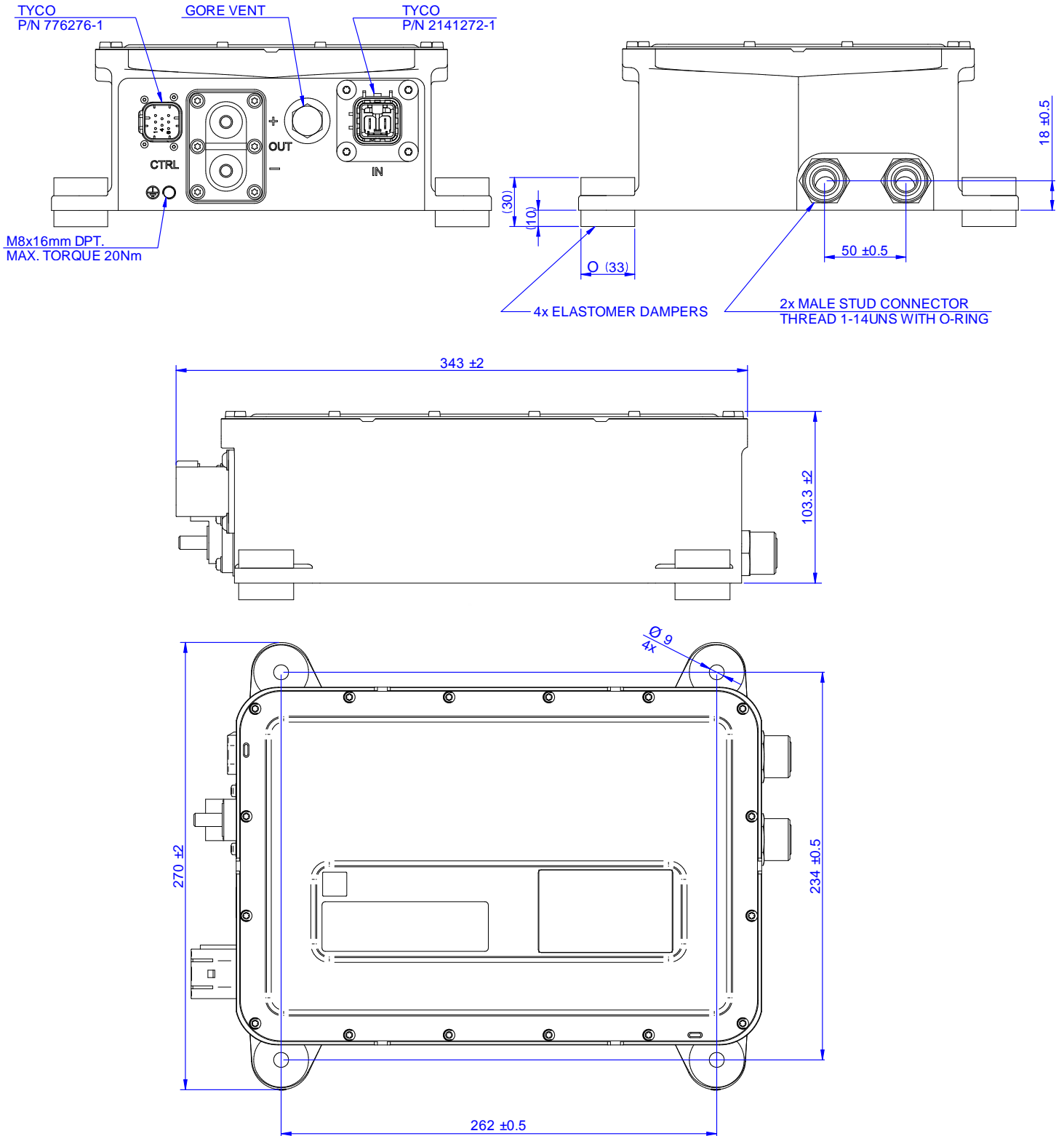

700DNC40-12-xG

Mechanical Drawings - Convection Cooled Model

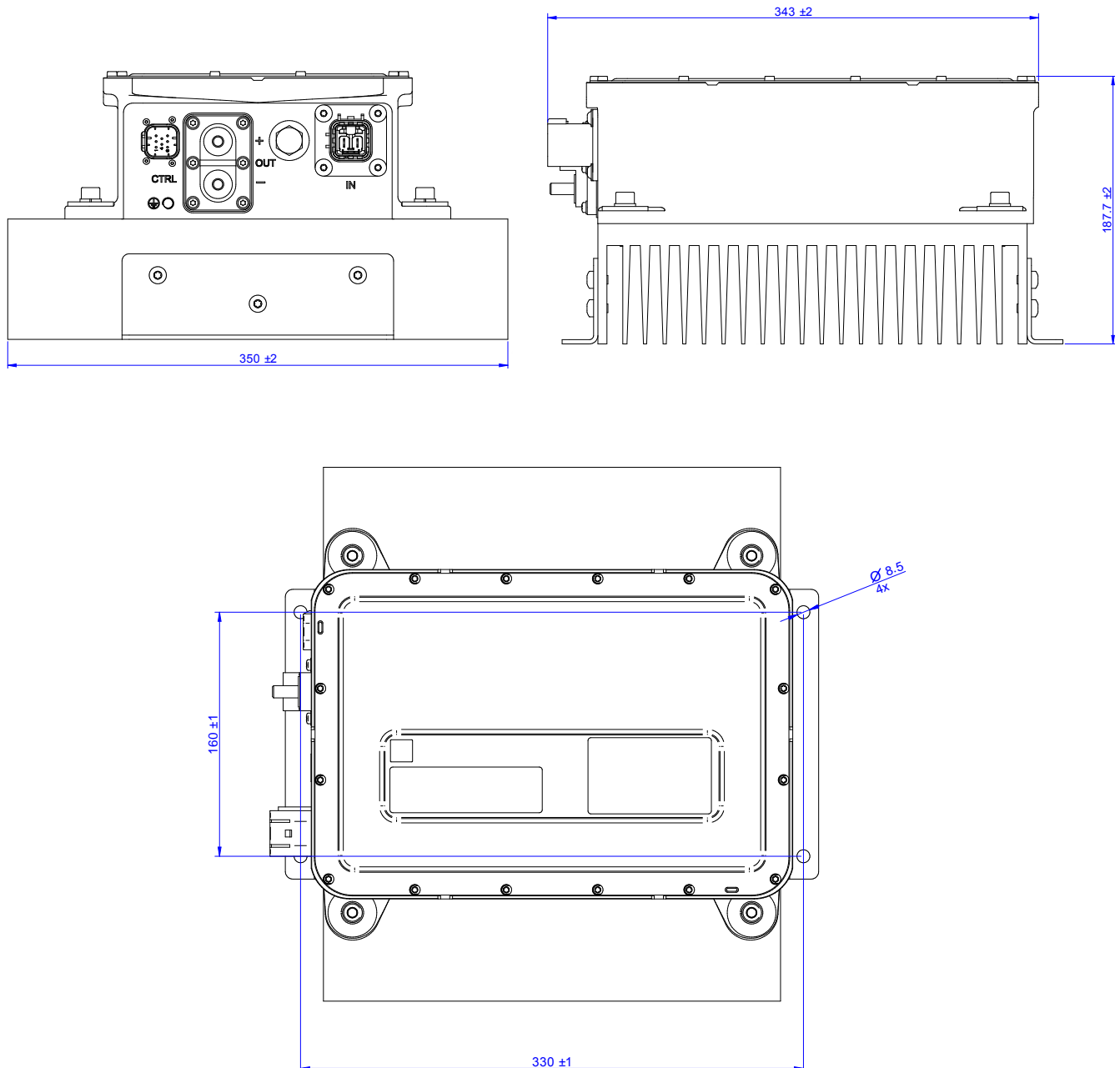

For more information on these products consult: tech.support@psbel.com

NUCLEAR AND MEDICAL APPLICATIONS - Products are not designed or intended for use as critical components in life support systems, equipment used in hazardous environments, or nuclear control systems.

TECHNICAL REVISIONS - The appearance of products, including safety agency certifications pictured on labels, may change depending on the date manufactured. Specifications are subject to change without notice.

Компания «Океан Электроники» предлагает заключение долгосрочных отношений при поставках импортных электронных компонентов на взаимовыгодных условиях!

Наши преимущества:

- Поставка оригинальных импортных электронных компонентов напрямую с производств Америки, Европы и Азии, а так же с крупнейших складов мира;
- Широкая линейка поставок активных и пассивных импортных электронных компонентов (более 30 млн. наименований);
- Поставка сложных, дефицитных, либо снятых с производства позиций;
- Оперативные сроки поставки под заказ (от 5 рабочих дней);
- Экспресс доставка в любую точку России;
- Помощь Конструкторского Отдела и консультации квалифицированных инженеров;
- Техническая поддержка проекта, помощь в подборе аналогов, поставка прототипов;
- Поставка электронных компонентов под контролем ВП;
- Система менеджмента качества сертифицирована по Международному стандарту ISO 9001;
- При необходимости вся продукция военного и аэрокосмического назначения проходит испытания и сертификацию в лаборатории (по согласованию с заказчиком);
- Поставка специализированных компонентов военного и аэрокосмического уровня качества (Xilinx, Altera, Analog Devices, Intersil, Interpoint, Microsemi, Actel, Aeroflex, Peregrine, VPT, Syfer, Eurofarad, Texas Instruments, MS Kennedy, Miteq, Cobham, E2V, MA-COM, Hittite, Mini-Circuits, General Dynamics и др.);

Компания «Океан Электроники» является официальным дистрибьютором и эксклюзивным представителем в России одного из крупнейших производителей разъемов военного и аэрокосмического назначения «JONHON», а так же официальным дистрибьютором и эксклюзивным представителем в России производителя высокотехнологичных и надежных решений для передачи СВЧ сигналов «FORSTAR».



JONHON

«JONHON» (основан в 1970 г.)

Разъемы специального, военного и аэрокосмического назначения:

(Применяются в военной, авиационной, аэрокосмической, морской, железнодорожной, горно- и нефтедобывающей отраслях промышленности)

«FORSTAR» (основан в 1998 г.)

ВЧ соединители, коаксиальные кабели, кабельные сборки и микроволновые компоненты:

(Применяются в телекоммуникациях гражданского и специального назначения, в средствах связи, РЛС, а так же военной, авиационной и аэрокосмической отраслях промышленности).



Телефон: 8 (812) 309-75-97 (многоканальный)

Факс: 8 (812) 320-03-32

Электронная почта: ocean@oceanchips.ru

Web: <http://oceanchips.ru/>

Адрес: 198099, г. Санкт-Петербург, ул. Калинина, д. 2, корп. 4, лит. А