

ENS210

Relative Humidity and Temperature Sensor with I²C Interface

General Description

The ENS210 integrates one relative humidity sensor and one high-accuracy temperature sensor. The device is encapsulated in a QFN4 package and includes an I²C slave interface for communication with a master processor.

Ordering Information and Content Guide appear at end of datasheet.

Key Benefits and Features

The benefits and features of ENS210, Relative Humidity and Temperature Sensor with I²C Interface are listed below:

Figure 1:
Added Value of Using ENS210

Benefits	Features
<ul style="list-style-type: none"> Ultra-accurate 	<ul style="list-style-type: none"> Temperature sensor ($\pm 0.2^{\circ}\text{C}$) Relative humidity sensor ($\pm 3.5\% \text{RH}$)
<ul style="list-style-type: none"> Wide sensing range 	<ul style="list-style-type: none"> Temperature operating range (-40°C to 100°C) Relative humidity operating range (0% to 100%)
<ul style="list-style-type: none"> Wide operating voltage 	<ul style="list-style-type: none"> 1.71V to 3.60V
<ul style="list-style-type: none"> Small foot-print 	<ul style="list-style-type: none"> 2.0mm x 2.0mm x 0.75mm
<ul style="list-style-type: none"> Industry standard two-wire interface 	<ul style="list-style-type: none"> Standard (100kbit/s) and fast (400kbit/s) I²C
<ul style="list-style-type: none"> Low power 	<ul style="list-style-type: none"> Automatic low-power standby when not measuring <ul style="list-style-type: none"> Active current: $6.6\mu\text{A}$ @ 1Hz (1.8V) Standby current: 40nA
<ul style="list-style-type: none"> Cost effective 	<ul style="list-style-type: none"> Digital pre-calibrated relative humidity and temperature sensor Output directly in %RH and Kelvin Wide supply voltage range
<ul style="list-style-type: none"> High reliability 	<ul style="list-style-type: none"> Long-term stability

Applications

The ENS210 applications include:

- Portable devices for personal health and wellness
- Air cleaners, air purifiers and smart thermostats
- Weather stations
- Home appliances, such as washing machines, dishwasher, and dryers
- Baby monitoring devices
- Transportation condition monitoring

Block Diagram

The internal block diagram of ENS210 is shown in [Figure 2](#). The I²C (communication) interface is connected to a controller which acts as the command interpreter and as bus master of the internal Advanced Peripheral Bus (APB). The memory and sensors are slaves of the APB. The MTP memory is used to store the sensor calibration parameters and unique ID.

To reduce power consumption the controller only powers the measurement engine when needed.

Figure 2:
Functional Blocks of ENS210

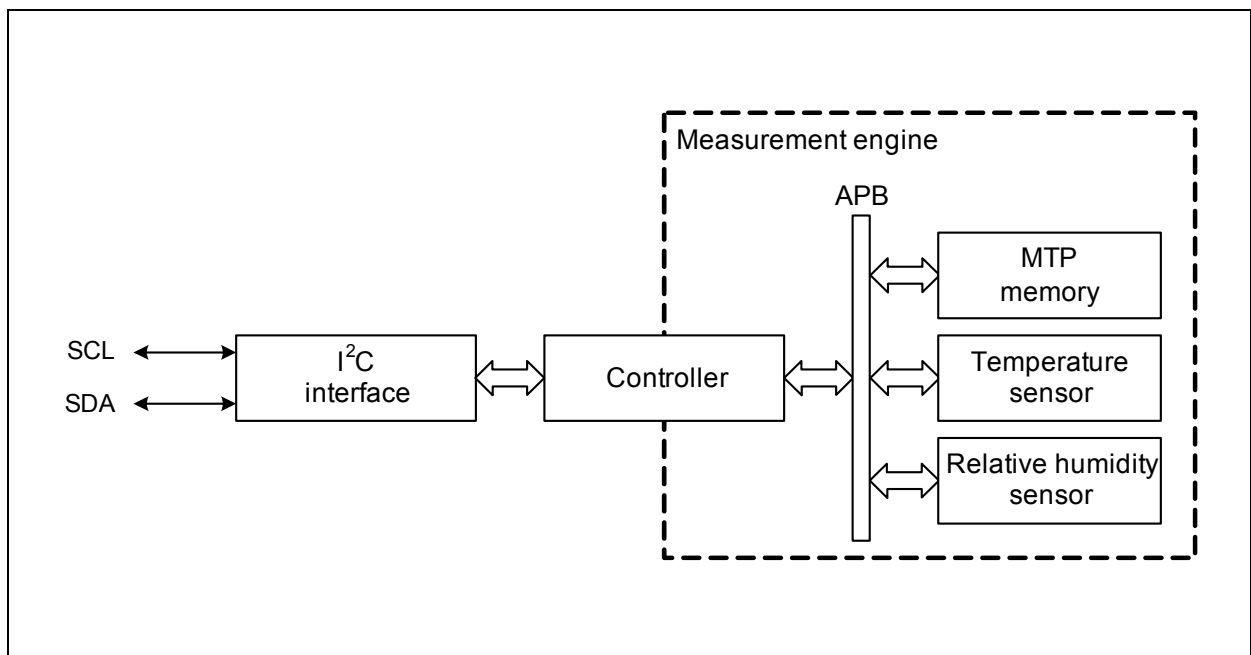

Pin Assignments

The ENS210 pin assignment is described in [Figure 3](#) and [Figure 4](#).

Figure 3:
Pin Diagram of ENS210

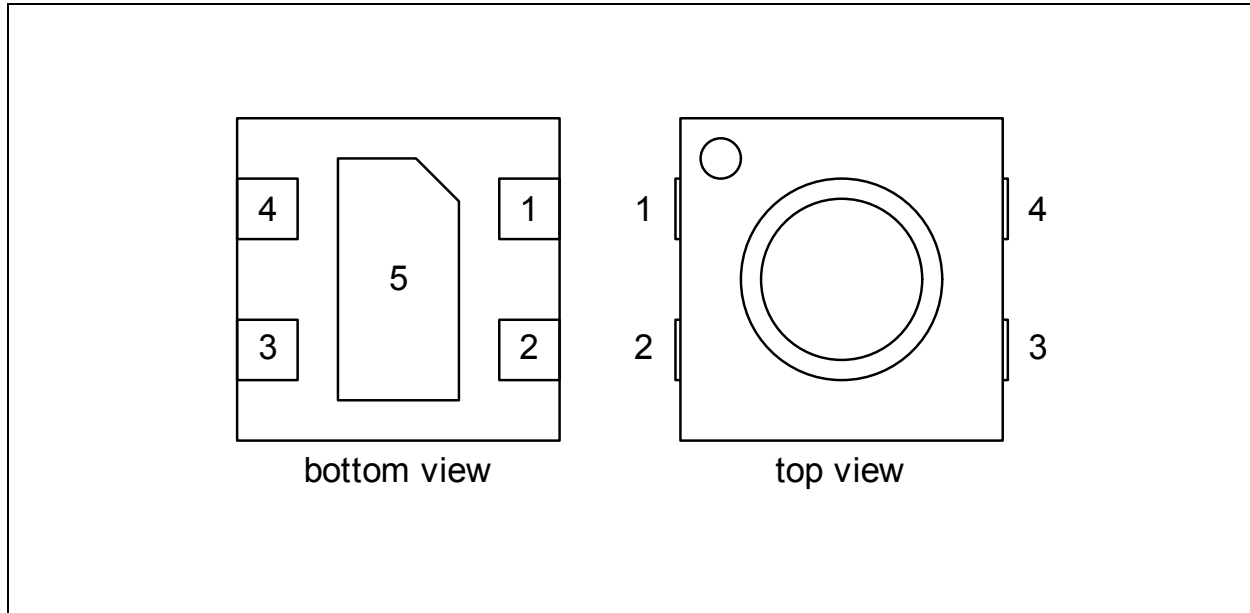

Figure 4:
Pin Description of ENS210

Pin Number	Pin Name	Description
1	V_{DD}	Supply voltage
2	SCL	I ² C bus serial clock input (SCL)
3	SDA	I ² C bus serial bidirectional data line (SDA)
4	V_{SS}	Ground supply voltage; must be connected
5	V_{SS}	Ground supply voltage; must be connected

Absolute Maximum Ratings

Stresses beyond those listed under [Absolute Maximum Ratings](#) may cause permanent damage to the device. These are stress ratings only. Functional operation of the device at these or any other conditions beyond those indicated under [Electrical Characteristics](#) is not implied. Exposure to absolute maximum rating conditions for extended periods may affect device reliability.

Figure 5:
Absolute Maximum Ratings of ENS210

Symbol	Parameter	Min	Max	Units	Comments
Electrical Parameters					
V_{DD}	Supply voltage	-0.30	4.60	V	
I_{lu}	Latch-up current		100	mA	I/O; $-0.5V_{DD} < V_I < 1.5V_{DD}$; $T_J < 125^\circ\text{C}$
Electrostatic Discharge					
ESD_{HBM}	Human body model; all pins	± 2000		V	JEDEC JS-001-2014
ESD_{CDM}	Charged model device; all pins	± 500		V	JEDEC JS-002-2014
Operating and Storage Conditions					
MSL	Moisture sensitivity level	1			Maximum floor life time is unlimited
T_{STRG}	Storage temperature	10	50	$^\circ\text{C}$	
RH_{NC}	Relative humidity (non-condensing)	20	60	%RH	Preferably in sealed ESD bag
T_A	Operating ambient temperature	-40	100	$^\circ\text{C}$	
H_A	Operating ambient relative humidity	0	100	%RH	

Electrical Characteristics

All limits are guaranteed. The parameters with min and max values are guaranteed with production tests or SQC (Statistical Quality Control) methods.

Figure 6:
Electrical Characteristics

Symbol	Parameter	Conditions	Min	Typ ⁽¹⁾	Max	Unit
V_{DD}	Supply voltage	Max ripple 100mV _{pp} between 0-1MHz	1.71	1.80 (3.30)	3.60	V
I_{DD}	Supply current	Standby state		0.04 (0.5)		μA
		Continuous run mode		58 (61)		μA
		T and RH measurement at 1Hz		6.6 (7.1)		μA
V_{IH}	High-level input voltage		$0.7 \times V_{DD}$		$V_{DD} + 0.5$	V
V_{IL}	Low-level input voltage		-0.5		$0.3 \times V_{DD}$	V
I_{OL}	Low-level output current	$V_{OL} = 0.4V$	3			mA
		$V_{OL} = 0.6V$	6			mA

Note(s):

1. Values in parenthesis are for $V_{DD}=3.30$ V.
2. $T_A = 25$ °C and at 1.80 V supply voltage, unless otherwise specified

I²C Timing Characteristics

ENS210 is compliant to the I²C standard; it supports standard and fast mode as per I²C-bus specifications [UM10204, I²C-bus specification and user manual, Rev. 6, 4 April 2014].

Temperature Sensor Characteristics

Figure 7:
Temperature Sensor Characteristics

Symbol	Parameter	Conditions	Min	Typ	Max	Unit
T _{range}	Temperature range		-40		100	°C
T _{acc}	Temperature accuracy ⁽³⁾	T _A = 0°C to 70°C; 3σ			0.2	°C
		T _A = -40°C to 100°C; 3σ			0.5	°C
T _{res}	Temperature resolution			0.016		°C
t _{resp}	Response time ⁽²⁾	T step of 10°C by submersion (in 0°C to 70°C range); τ63 % ⁽¹⁾		1		s
T _{rep}	Temperature repeatability	3σ of consecutive measurement values at constant conditions	-0.1		0.1	°C
ΔT	Temperature long term drift			0.005		°C / year

Note(s):

- 63% indicates that if a T step of 10°C, e.g. from 20°C to 30°C is made, it will take t_{resp} seconds to reach 63% of that step.
- In an application the temperature response time depends on heat conductivity of the sensor PCB.
- Accuracy specifications are defined before soldering of the product in an application. Refer to ENS210 application note. Maximum accuracy specification refers to 3 standard deviations assuming normal distribution of accuracy errors. After industrial calibration of sensors, each sensor is tested on typical room conditions (e.g. 25°C 45%RH) and only sensors passing the verification qualify for customer deliveries.

Relative Humidity Sensor Characteristics

Figure 8:
Relative Humidity Sensor Characteristics

Symbol	Parameter	Conditions	Min	Typ	Max	Unit
H_{range}	Relative humidity range		0		100	%RH
H_{acc}	Relative humidity accuracy ⁽³⁾	$T_A = 25^\circ\text{C}$; RH = 20%RH to 80%RH; excluding hysteresis		2.2	3.5	%RH
		$T_A = 25^\circ\text{C}$; RH = 0%RH to 100%RH; excluding hysteresis		4	5	%RH
H_{res}	Relative humidity resolution			0.03		%RH
t_{resp}	Response time ⁽⁴⁾	RH step of 20%RH (in 40%RH to 80%RH range); $\tau_{63\%}$ ⁽¹⁾ ; 1 m/s flow; $T_A = 25^\circ\text{C}$		3	5	s
H_{hys}	Relative humidity hysteresis	$T_A = 25^\circ\text{C}$; RH = 20%RH to 90%RH; 30minutes exposure time		± 0.7		%RH
H_{rep}	Relative humidity repeatability	3σ of consecutive measurement values at $T_A = 25^\circ\text{C}$ and RH = 40%RH		± 0.1		%RH
ΔH	Relative humidity long term drift ⁽²⁾	$T_A = 25^\circ\text{C}$		0.25		%RH / year

Note(s):

- 63% indicates that if an RH step of 20%RH is made, e.g. from 40%RH to 60%RH, it will take t_{resp} seconds to reach 63% of that step.
- Values are linearized averages over the lifetime of the product. Due to non-linear behavior a larger drift is expected in the first years.
- Typical and maximum accuracy specification refers to, respectively, 2 and 3 standard deviations, assuming normal distribution of accuracy error.
- Device only performance. Application response time will depend on the design-in of the sensor

System Timing Characteristics

Figure 9:
System Timing Characteristics

Symbol	Parameter	Conditions	Min	Typ	Max	Unit
$t_{booting}$	Booting time ⁽¹⁾			1	1.2	ms
t_{conv}	Conversion time	T only, single shot (includes $t_{booting}$)		105	110	ms
		T only, continuous		104	109	ms
		T and RH, single shot (includes $t_{booting}$)		122	130	ms
		T and RH, continuous		225	238	ms

Note(s):

1. Time in transient state *booting* (see [Figure 10](#)).

Functional Description

The ENS210 integrates two sensor blocks: temperature and relative humidity.

The device is normally in the *standby* state (Figure 10): the measurement engine (see Figure 2) is unpowered, but the I²C interface is operational and register write/read operation can be performed. When a measurement command is given, the device is first *booting* to *active* then it starts a measurement. When the measurement is completed, the device returns to the *standby* state. Since the I²C interface is operational in *standby*, the measurement result can be read out.

Figure 10:
The ENS210 Power States

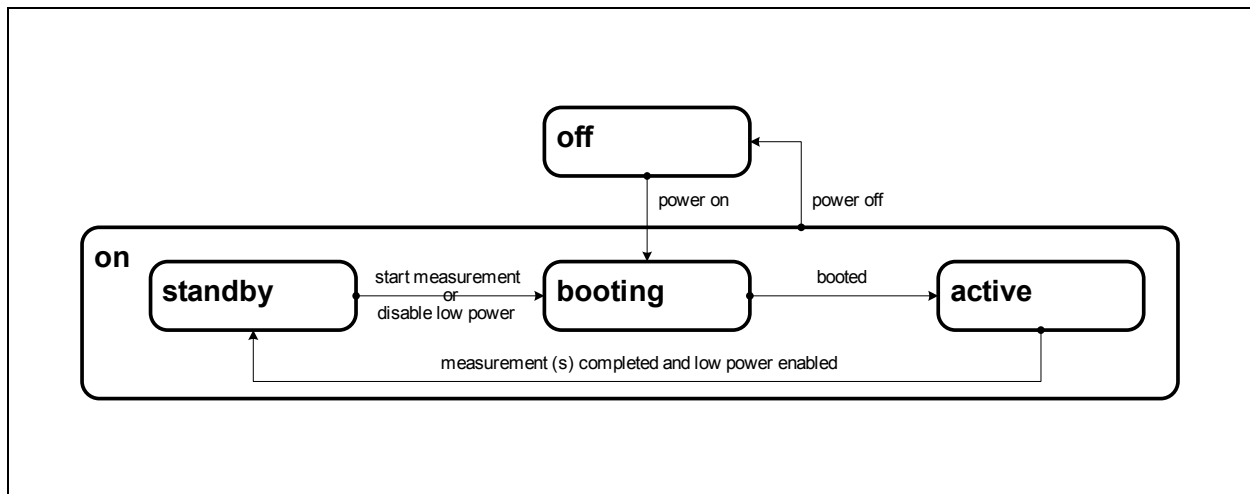

In continuous run mode (see Register [SENS_RUN](#)) or when low power is disabled (see Register [SYS_CTRL](#)), the device remains in *active* state.

The system power status is observable (see Register [SENS_STAT](#)).

When powering up from *off*, the device is first *booting* to *active*, but then falls immediately back to *standby* (since no measurement is pending, and by default low power is enabled).

Note that the *booting* state is a transient state (the system automatically transitions to the next state – *active*); the booting time is given in [Figure 9](#).

Temperature Sensor

The temperature sensor block (Figure 11) determines the ambient temperature, and outputs a calibrated value in Kelvin.

Figure 11:
Band Gap Temperature Measurement

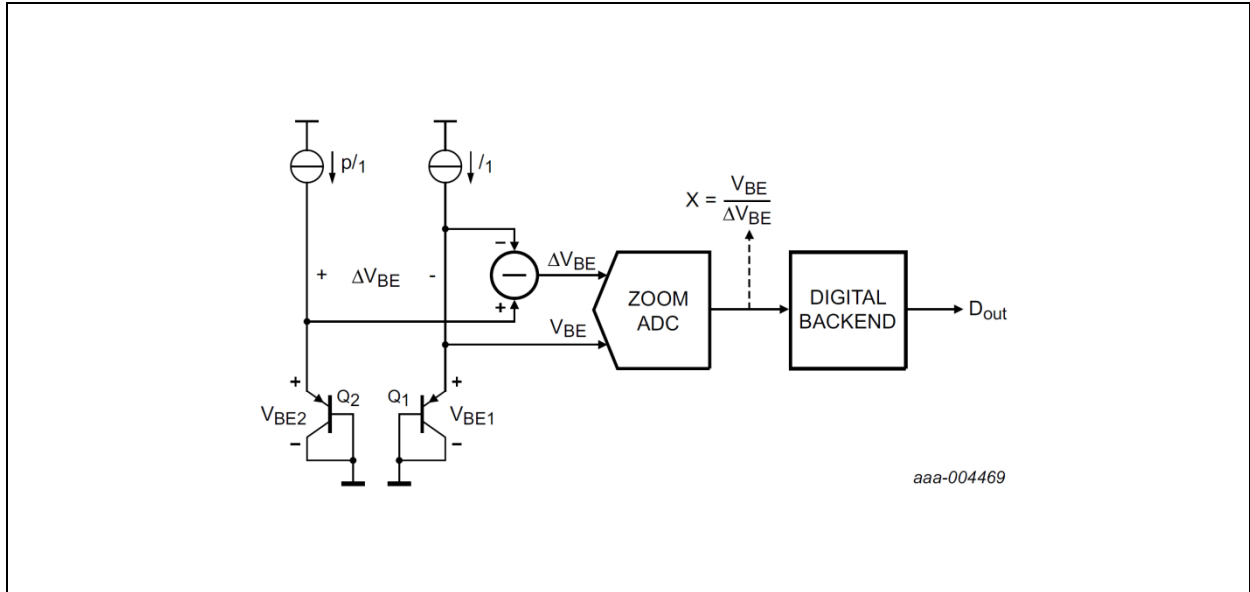

The temperature is measured using a high-precision (12 bits) zoom-ADC. The analog part is able to measure a strongly temperature dependent $X = V_{BE}/\Delta V_{BE}$. The X is found by first applying a coarse search (successive approximation), and then a sigma-delta in a limited range. The accuracy of the sensor is shown in Figure 12. The conversion time is shown in Figure 9.

Figure 12:
Absolute Accuracy of the Temperature Sensor

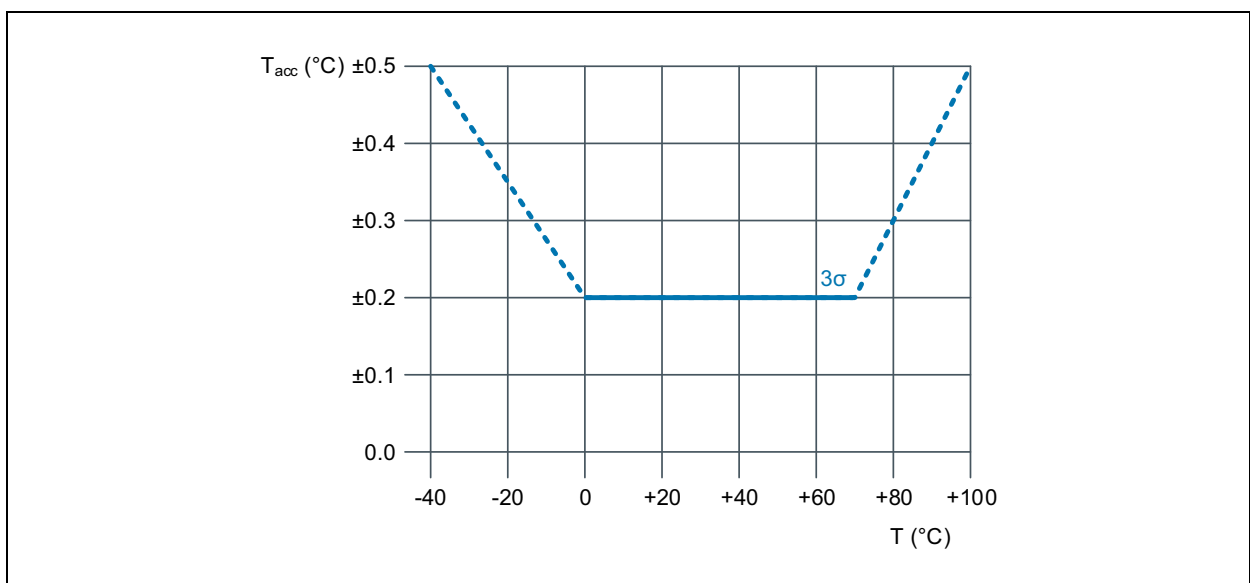

Note(s):

- 1. Dash line indicates natural physical behavior

Relative Humidity Sensor

The relative humidity sensor as shown in Figure 13 determines the ambient relative humidity and outputs a calibrated value in %RH. The transducer (the C_x on the top left) consists of a large-area capacitor covered with a humidity-sensitive material. The capacitance change is proportional to the change in relative humidity, and has a linear dependence on temperature. The capacitance is measured by a high-precision 2nd order sigma-delta converter.

Figure 13:
Relative Humidity Sensor

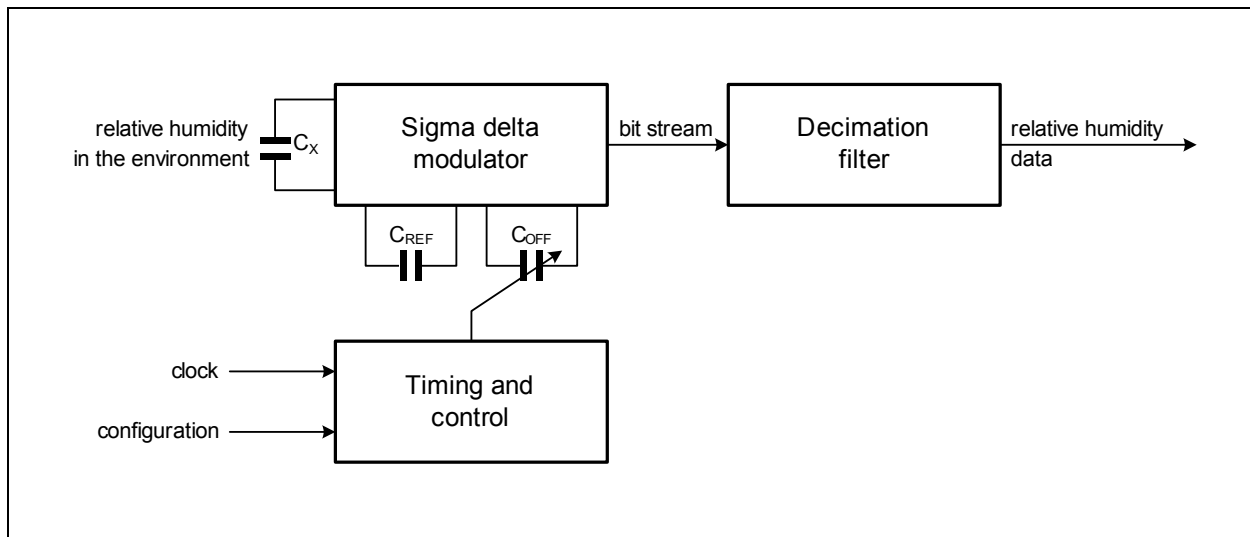

Reading the relative humidity sensor will output a temperature compensated value. The accuracy of the sensor is shown in Figure 14. The conversion time is shown in Figure 9.

Figure 14:
Absolute Accuracy of the Relative Humidity Sensor at 25°C

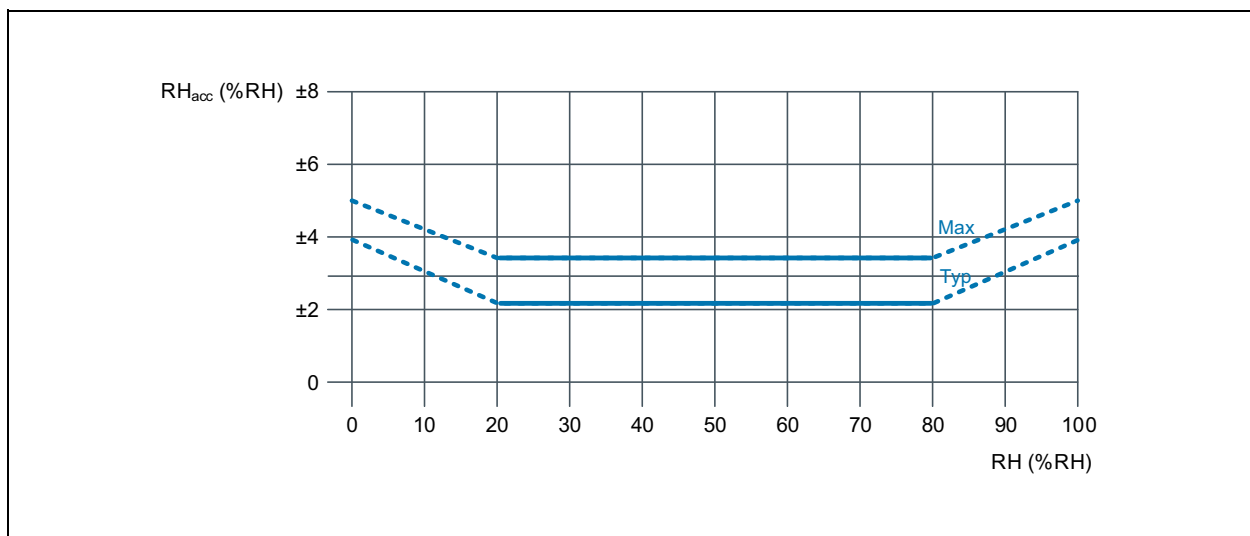

Note(s):

- 1. Dash line indicates natural physical behavior

RH Accuracy at Various Temperatures

Typical RH accuracy at 25°C is defined in Figures 8 and 14. The relative humidity accuracy has also been evaluated at temperatures other than 25°C. The values shown in Figure 15 are an indication only, which may be important for your application, but are not guaranteed.

Figure 15:
Accuracy of Relative Humidity Measurements (%RH) as Function of Temperature and Relative Humidity

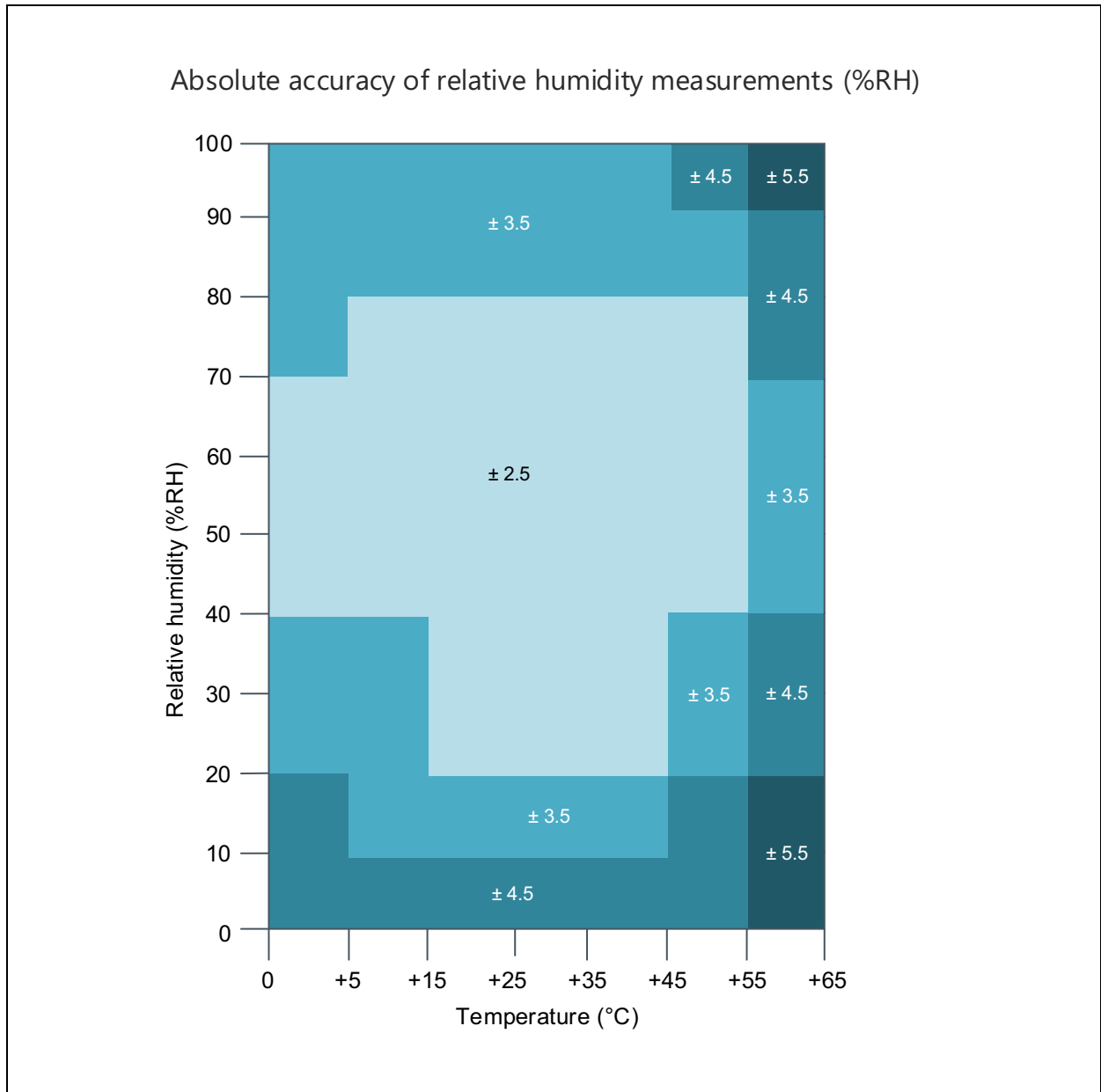

The I²C Interface

The ENS210 is an I²C slave device. The I²C interface supports standard (100kbit/s) and fast (400kbit/s) mode.

Details on I²C protocol is according to *I²C-bus specifications [UM10204, I²C-bus specification and user manual, Rev. 6, 4 April 2014]*.

The device applies all mandatory I²C protocol features for slaves: START, STOP, Acknowledge, 7-bit slave address. ENS210 does not use clock stretching.

None of the other optional features (10-bit slave address, General Call, Software reset, or Device ID) are supported, nor are the master features (Synchronization, Arbitration, START byte).

I²C Operations on Registers

The ENS210 uses a register model to interact with it. This means that an I²C master can write a value to one of the registers of a slave, or that it can read from one of the registers of the slave. In the ENS210, registers are addressed using 1 byte. The values stored in a register are also 1 byte. However, the ENS210 implements “auto increment” which means that it is possible to read, for example, two bytes by supplying the address of the first byte and then reading two bytes.

Figure 16:
I²C Transaction Formats

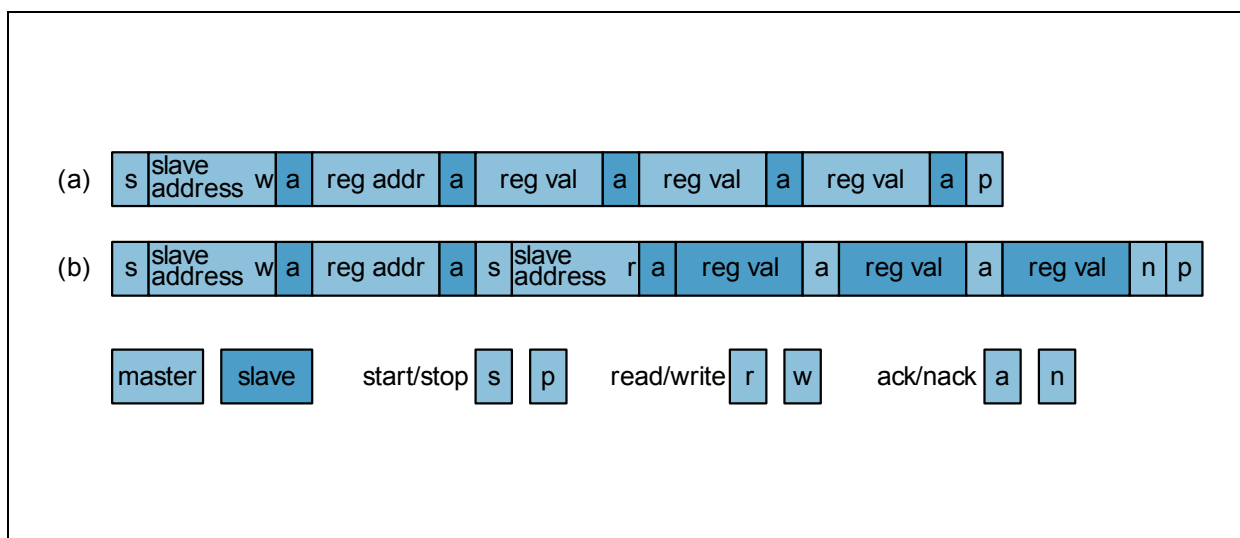

A typical *write* transaction (see [Figure 16 a](#)) therefore has the following format. The master initiates a transaction with a so-called start condition “s”. This blocks the bus. Next, the master sends the 7 bits ENS210 *slave address* followed by a 1 bit direction (a 0 indicating write “w”). This byte is acknowledged “a” by the slave. The master continues by sending the 8 bit *register address*, which is acknowledged by the slave.

This register address is stored in an internal CRA register (“Current Register Address”). Finally, the master sends the 8 bit *register value*, which is acknowledged by the slave (or nack’ed when the address is not writeable). This value is written to the register pointed to by the CRA, and the CRA is incremented by 1. Optionally, the master sends more 8 bit values, for the next registers (auto incrementing CRA), each of which is (n)ack’ed by the slave. Finally, the master generates a stop condition “p”, unblocking the bus for other transactions.

A *read* transaction (see [Figure 16 b](#)) starts with a write (of the register address), followed by a read. Consequently, it has the following format. The master initiates the transaction with a start condition. Next, the master sends the 7 bits ENS210 *slave address* followed by a 1 bit direction (a 0 indicating write). This byte is acknowledged by the slave. The master continues by sending the 8 bit *register address*, which is acknowledged by the slave and stored in the CRA register. Then the master sends another start condition (a so-called repeated start condition, keeping the bus blocked) followed by the 7 bits ENS210 *slave address* followed by a 1 bit direction (a 1 indicating read “r”), which is acknowledged by the slave. Next, the slave sends an 8 bits *register value* from the register pointed to by the CRA register, and the CRA is incremented by 1. This byte is acknowledged by the master. The master may read another 8 bits (auto increment feature) from the slave and acknowledge that, until the master sends a nack “n” followed by a stop to unblock the bus.

The ENS210 has an 8 bit address space, potentially addressing 256 registers. In reality, only few addresses are actually backed by a register (see [Register Overview](#)). All other addresses are *reserved*. A write transaction to a reserved (or read-only) register causes a not-acknowledge. A read transaction for a reserved register will return a 0.

The I²C Slave Address

The ENS210 is an I²C slave device with a fixed slave address of 0x43. This means that the first byte after a start condition is 1000 011x, where x indicates the data direction, so 0x86 (1000 0110) for write and 0x87 (1000 0111) for read.

Sensor Control

The ENS210 contains a temperature and a relative humidity sensor. Both sensors have two run modes: single shot run mode and continuous run mode (enabled via SENS_RUN), see [Figure 17](#).

Figure 17:
The Sensor Modes

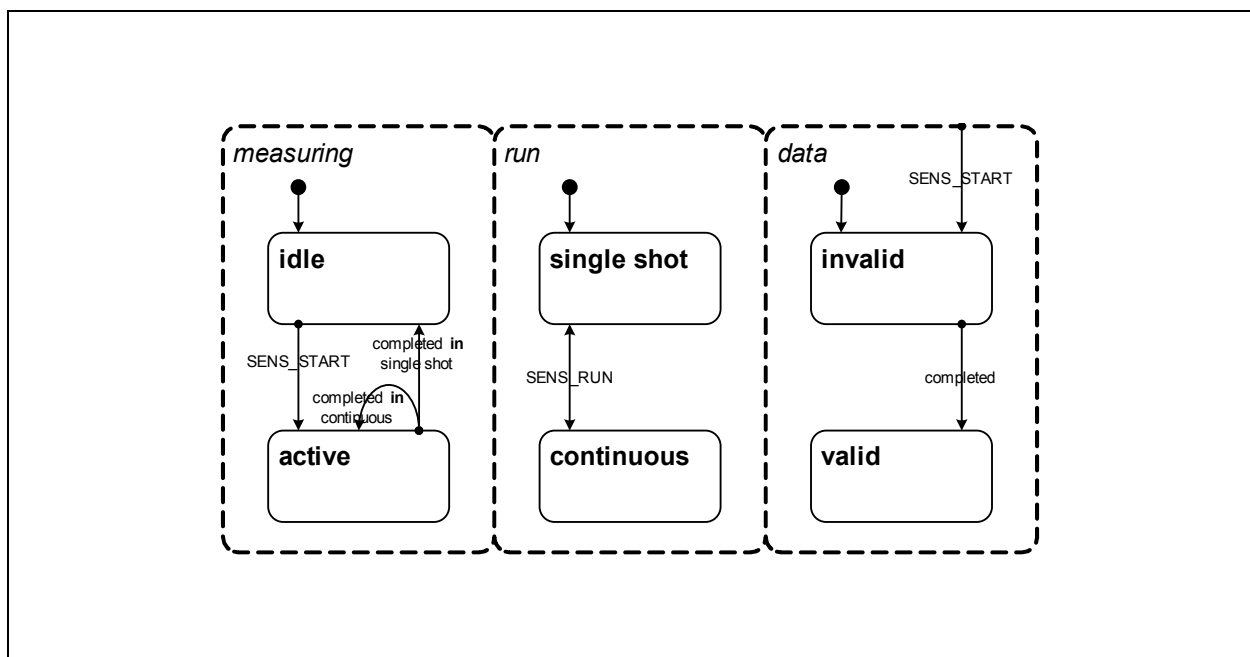

When in the *single shot* run mode, starting a measurement is under control of the master. By default a sensor is idle; it can be started by writing a 1 to the corresponding bit in SENS_START. After a start, the sensor stops when the measurement is completed. Whether a sensor is idle or active measuring can be detected by reading SENS_STAT. The measured values can be obtained via their respective readout registers (T_VAL and H_VAL). Writing to SENS_STOP in single shot has no effect.

When in the *continuous* run mode, the sensor performs measurement after measurement after a 1 is written to the corresponding bit in SENS_START. The result of each measurement is stored in the aforementioned readout registers. Writing 1 to the corresponding bit in SENS_STOP stops the repeat cycle after the ongoing measurement is completed.

The device operates in a step-wise way. In each step, either one or both sensors are active. The step ends when the measurement(s) are completed. For the next step, the device

inspects its register settings, and either one or both sensors are activated again, or there is no measurement request and the device goes into standby (unless low power is disabled by SYS_CTRL).

This means that multiple writes to START during a step have no effect; the measurement is started once, and only a write to START after the measurement has completed starts the measurement again. Similarly, multiple writes to STOP have no effect; when the measurement completes (in continuous mode) the stop request is effectuated once. When START and STOP are both requested, the measurement is started, and when completed, stopped.

Sensor Timing

There are differences between single shot measurements and continuous measurements. Figure 18 shows the timing of a single shot T measurement.

Figure 18:
Single Shot Temperature Measurement

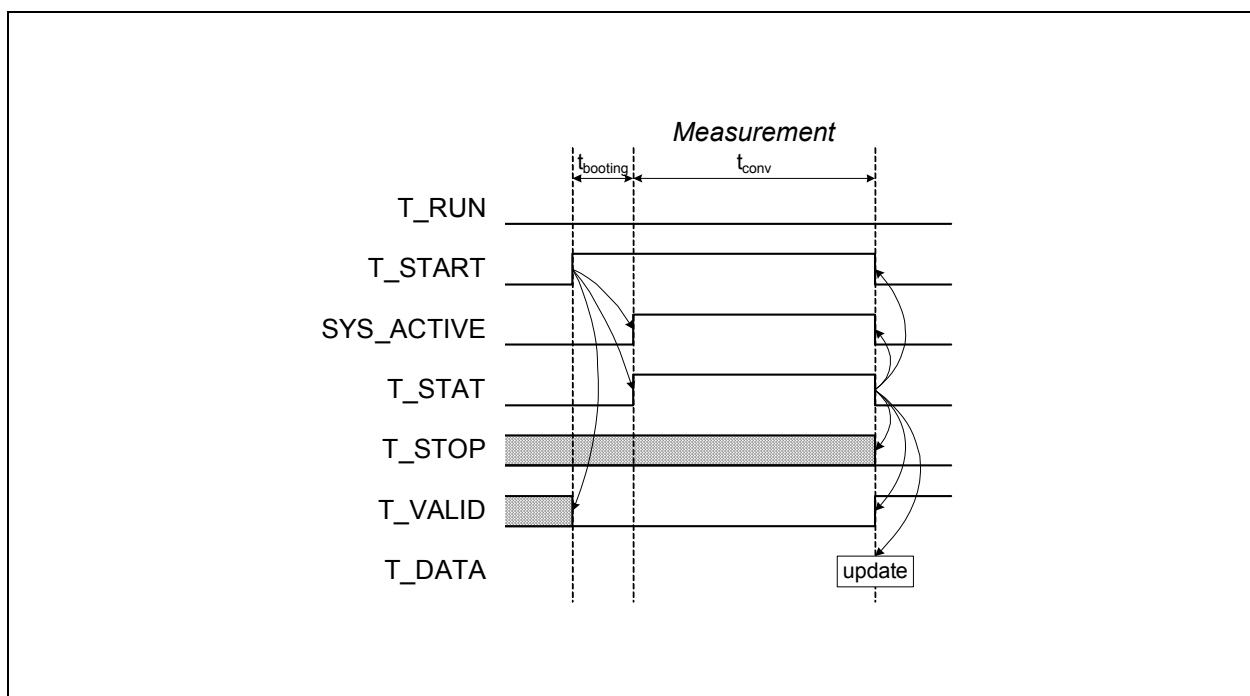

Signal T_RUN is written low to select a single shot measurement. Note that T_STOP is typically low (cleared by a previous measurement), but its state is ignored in a single shot measurement. T_START is written high to start measuring: T_VALID in T_VAL is cleared and the device starts *booting* to *active*. Once active SYS_ACTIVE goes high, and measurement starts (T_STAT goes high).

When the measurement is completed (T_STAT goes low) the data register (T_DATA) becomes valid (T_VALID goes high) and the device goes back to *standby* (SYS_ACTIVE goes low). The T_START and T_STOP are cleared.

Figure 19:
Continuous Temperature Measurement

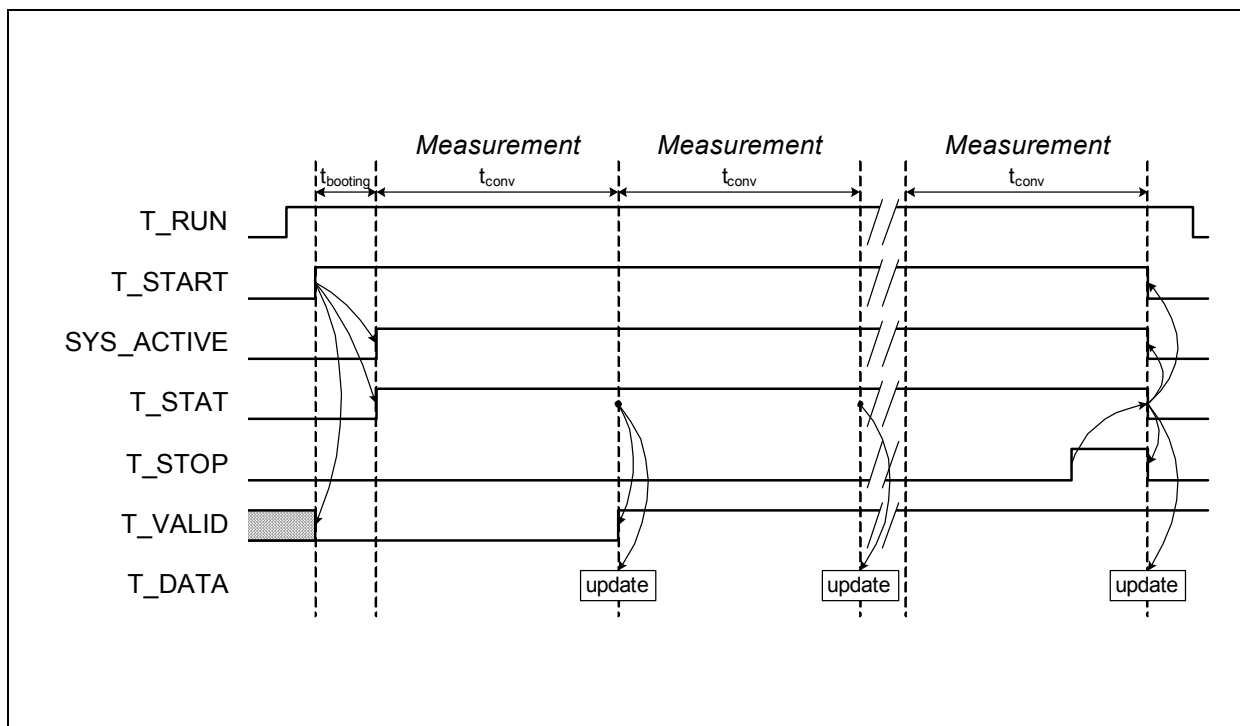

Figure 19 shows the timing of a continuous T measurement.

Signal T_RUN is written high to select a continuous measurement. Note that T_STOP is typically low (cleared by a previous measurement), and it should stay low otherwise continuous mode will stop after one measurement. T_START is written high to start measuring: T_VALID in T_VAL is cleared and the device starts *booting* to *active*. Once *active* SYS_ACTIVE goes high, and measurement starts (T_STAT goes high).

When the first measurement is completed the data register (T_DATA) becomes valid (T_VALID goes high), and the device starts a new measurement. When the next measurement is completed the data register (T_DATA) is updated; T_VALID stays high. The device starts a new measurement.

At some point in time, a stop command is given (T_STOP is written high). As soon as the current measurement is completed, the data register (T_DATA) is once more updated and the device goes back to *standby* (SYS_ACTIVE goes low). The T_START and T_STOP are cleared.

Note that writes to the SENS_XXX registers only take effect when no measurement is ongoing. In other words, measurements are always sequential (so we can have three types: T only, RH only or T and RH and changes occur when the measurements are finished).

The Sensor Readout Registers

The sensor readout registers (T_VAL and H_VAL) consist of three parts: the actual measured data, a valid flag and a checksum (see Figure 20). It is not mandatory to read the valid flag or the checksum when reading the data.

Figure 20:
The Layout of the Sensor Readout Registers

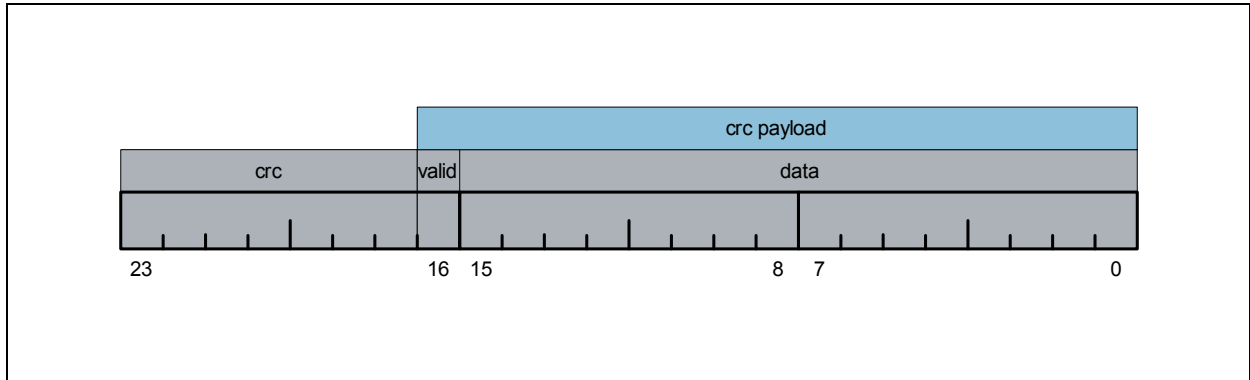

The *checksum* is a cyclic redundancy check over the data and the valid flag; the stored checksum is the result of CRC-7 (polynomial x^7+x^3+1 , see https://en.wikipedia.org/wiki/Cyclic_redundancy_check) with $0x7F$ as initial vector (i.e. with all bits flipped), see [Computing CRC-7 for sample C code](#).

The *valid* flag is cleared when a measurement is started (irrespective of the run mode). Once the measurement is completed the valid flag is set. In continuous mode, a new measurement is then started without clearing the valid flag; so data is always valid after the first measurement (but it might be several milliseconds old).

The *data* field is a 16 bits fixed point number, whose format and unit depends on the sensor (see [Register T_VAL](#) and [Register H_VAL](#)).

To ensure consistent view, these multi-byte readout registers are double buffered. When the first byte (i.e. the byte with the lowest register address) is read, the device copies all bytes from the measurement registers to the I²C registers, and then the value from the first I²C register is returned. Reads to the other bytes of the multi-byte register (i.e. with higher register addresses) are always directly from the I²C registers.

Computing CRC-7

CRC algorithm uses a 7 bit polynomial (see lines 4, 5, and 6), and a 17 bit payload. The `crc7()` function below uses the following constants defining the CRC width, (the coefficients of the) polynomial and the initial vector (start value of the CRC), and some constants describing the payload data size.

```
//          7654 3210
// Polynomial 0b 1000 1001 ~ x^7+x^3+x^0
//          0x   8 9
#define CRC7WIDTH 7 // 7 bits CRC has polynomial of 7th order (has 8 terms)
#define CRC7POLY 0x89 // The 8 coefficients of the polynomial
#define CRC7IVEC 0x7F // Initial vector has all 7 bits high
// Payload data
#define DATA7WIDTH 17
#define DATA7MASK ((1UL<<DATA7WIDTH)-1) // 0b 0 1111 1111 1111 1111
#define DATA7MSB (1UL<<(DATA7WIDTH-1)) // 0b 1 0000 0000 0000 0000
```

The `crc7(val)` function returns the CRC-7 of a 17 bits value *val*.

```
// Compute the CRC-7 of 'val' (should only have 17 bits)
uint32_t crc7( uint32_t val ) {
    // Setup polynomial
    uint32_t pol= CRC7POLY;
    // Align polynomial with data
    pol = pol << (DATA7WIDTH-CRC7WIDTH-1);
    // Loop variable (indicates which bit to test, start with highest)
    uint32_t bit = DATA7MSB;
    // Make room for CRC value
    val = val << CRC7WIDTH;
    bit = bit << CRC7WIDTH;
    pol = pol << CRC7WIDTH;
    // Insert initial vector
    val |= CRC7IVEC;
    // Apply division until all bits done
    while( bit & (DATA7MASK<<CRC7WIDTH) ) {
        if( bit & val ) val ^= pol;
        bit >>= 1;
        pol >>= 1;
    }
    return val;
}
```

Suppose that T_VAL (address 30, 31 and 32) reads FD 49 0B, corresponding (little endian) with the number 0B49FD, see Figure 21. This leads to a CRC of 05 over a payload of 149FD. See the next paragraph for details on processing this data.

Figure 21:
T_VAL Readout

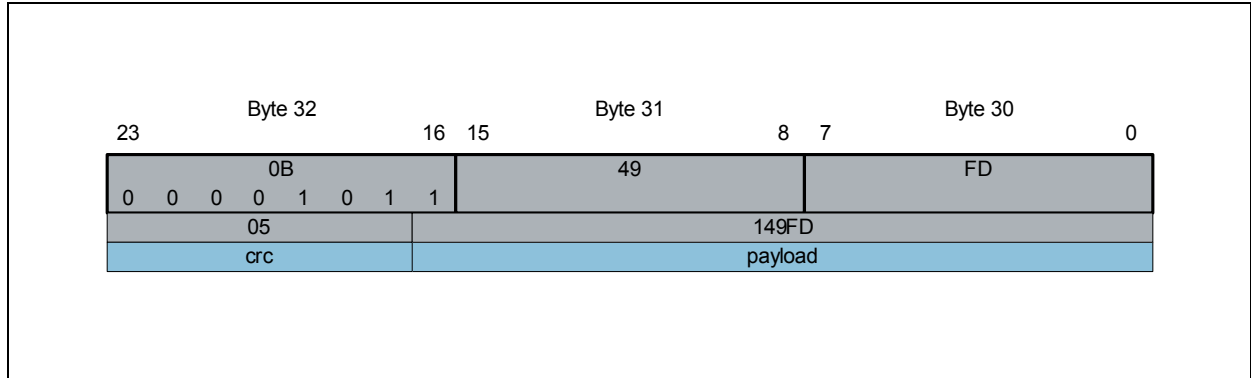

Processing T_VAL and H_VAL

This paragraph shows a possible implementation of reading T and RH.

The following fragment starts a combined single shot measurement, waits and reads the measurement results. It assumes the availability of `i2c_reg_write` and `i2c_reg_read` primitives as well as a sleep routine (`rtk_tsk_sleep`). The format specifiers in the `printf`'s are kept simple (`%d` instead of `%ld` or even `PRId32` from `inttypes.h`); they need adaptation on e.g. 16 bits platforms.

```
// Record I2C transaction status
bool i2c_ok= true;
// Start T and H (write 03 to register 22 in device 86)
uint8_t wbuf[]={ 0x03 };
i2c_ok &= i2c_reg_write(0x86, 0x22, wbuf, sizeof wbuf);
// Wait for measurements to complete
#define CONVERSION_TIME_T_H_MS 130
rtk_tsk_sleep(CONVERSION_TIME_T_H_MS);
// Read T and H (read 6 bytes starting from 0x30 in device 86)
uint8_t rbuf[6];
i2c_ok &= i2c_reg_read(0x86, 0x30, rbuf, sizeof rbuf);
// Extract T_VAL and H_VAL (little endian), assumes 32 bits wordsize
uint32_t t_val= (rbuf[2]<<16) + (rbuf[1]<<8) + (rbuf[0]<<0);
uint32_t h_val= (rbuf[5]<<16) + (rbuf[4]<<8) + (rbuf[3]<<0);
```

The following fragment processes the T measurement as available in `t_val`. It relies on the `crc7()` function as shown previously.

```
// Extract (and print) the fields
uint32_t t_data = (t_val>>0) & 0xffff;
uint32_t t_valid= (t_val>>16) & 0x1;
uint32_t t_crc = (t_val>>17) & 0x7f;
printf("ENS210: T: %06x %02x %01x %04x\n", t_val, t_crc, t_valid, t_data );
// Check the CRC
uint32_t t_payl = (t_val>>0) & 0x1ffff;
bool t_crc_ok= crc7(t_payl)==t_crc;
// Convert to float (and print)
float TinK = (float)t_data / 64; // Temperature in Kelvin
float TinC = TinK - 273.15; // Temperature in Celsius
float TinF = TinC * 1.8 + 32.0; // Temperature in Fahrenheit
printf("ENS210: T: (i2c=%d crc=%d valid=%d) %5.1fK %4.1fC %4.1fF\n", i2c_ok, t_crc_ok, t_valid, TinK, TinC, TinF);
```

The following fragment processes the RH measurement as available in `h_val`. It is similar to the `t_val` processing.

```
// Extract (and print) the fields
uint32_t h_data = (h_val>>0) & 0xffff;
uint32_t h_valid= (h_val>>16) & 0x1;
uint32_t h_crc = (h_val>>17) & 0x7f;
printf("ENS210: H: %06x %02x %01x %04x\n", h_val, h_crc, h_valid, h_data );
// Check the CRC
uint32_t h_payl = (h_val>>0) & 0x1ffff;
bool h_crc_ok= crc7(h_payl)==h_crc;
// Convert to float (and print)
float H = (float)h_data/512; // relative humidity (in %)
printf("ENS210: H: (i2c=%d crc=%d valid=%d) %2.0f%%\n", i2c_ok, h_crc_ok, h_valid, H);
```

If registers 30 to 35 would contain `fd 49 0b 6c 2e f5` (i.e. `T_VAL` in blue and `H_VAL` in green) the code would print

```
ENS210: T: 0b49fd 05 1 49fd
ENS210: T: (i2c=1 crc=1 valid=1) 296.0K 22.8C 73.0F
ENS210: H: f52e6c 7a 1 2e6c
ENS210: H: (i2c=1 crc=1 valid=1) 23%
```

Reading PART_ID and UID

The first 2 registers (PART_ID and UID) are only available in *active* state. There are two ways to read them:

- Dedicated read action
 - Disable low power (set LOW_POWER to 0)
 - Wait for $t_{booting}$ to get into *active* state (check SYS_ACTIVE to be 1)
 - Read the ID register(s)
 - Re-enable low power (set LOW_POWER to 1)
- Piggybacking on a measurement
 - Start a measurement (write 0b01, 0b10, or 011 to SENS_START)
 - Wait for $t_{booting}$ to get into *active* state (check SYS_ACTIVE to be 1)
 - Read the ID register(s)
 - Ensure the device is still in *active* state (check SYS_ACTIVE to be 1)

Register Description

This section describes the I²C registers of the ENS210.

Register Overview

Note that some registers are actually spread over multiple addresses. For example, T_VAL at address 30 is spread over 3 addresses (its “Size” is 3). This could be rephrased as follows: there are three registers T_VAL0, T_VAL1, and T_VAL2 at addresses 30, 31, and 32 respectively.

Figure 22:
Register Overview

Address	Name	Size	Access	Description
0x00	PART_ID	2	Read (active only)	Identifies the part as ENS210
0x02	<unused>	2	Read	
0x04	UID	8	Read (active only)	Unique identifier
0x0C	<reserved>	4		
0x10	SYS_CTRL	1	Read/Write	System configuration
0x11	SYS_STAT	1	Read	System status
0x12	<reserved>	14		
0x21	SENS_RUN	1	Read/Write	The run mode (single shot or continuous)
0x22	SENS_START	1	Write	Start measurement
0x23	SENS_STOP	1	Write	Stop continuous measurement
0x24	SENS_STAT	1	Read	Sensor status (idle or measuring)
0x25	<reserved>	11		
0x30	T_VAL	3	Read	Temperature readout
0x33	H_VAL	3	Read	Relative humidity readout
0x36	<reserved>	202		

Detailed Register Description

Register PART_ID (Address 0x00)

This 2 byte register identifies the part number in little endian (ENS210). This register is only available in *active* state; see [Reading PART_ID and UID](#) for instructions of reading it.

Figure 23:
Register PART_ID

Address 0x00		PART_ID		
Bits	Field Name	Default	Access	Field Description
15:0	PART_ID	0x0210	Read	Identifies this device as an ENS210

Register UID (Address 0x04)

This 8 byte register uniquely identifies a single device among all ENS210 devices. This register is only available in *active* state; see [Reading PART_ID and UID](#) for instructions of reading it.

Figure 24:
Register UID

Address 0x04		UID		
Bits	Field Name	Default	Access	Field Description
63:0	UID	Varies	Read	Unique device id

Register SYS_CTRL (Address 0x10)

This 1 byte register controls the system.

Figure 25:
Register SYS_CTRL

Address 0x10		SYS_CTRL		
Bits	Field Name	Default	Access	Field Description
7	RESET	0	Write	Write 1 to reset the device
6:1	<reserved>	0b000000	Read/Write	Keep to 0's
0	LOW_POWER	0b1	Read/Write	Controls the automatic low power. 0: Disabled (device stays in <i>active</i>) 1: Enabled (device goes to <i>standby</i> when measurement complete)

Register SYS_STAT (Address 0x11)

This 1 byte register indicates the system status.

Figure 26:
Register SYS_STAT

Address 0x11		SYS_STAT		
Bits	Field Name	Default	Access	Field Description
7:1	<reserved>	0b0000000	Read	Reads 0's
0	SYS_ACTIVE	0b1	Read	The system power state 0: System is in <i>standby</i> or <i>booting</i> state 1: System is in <i>active</i> state

Register SENS_RUN (Address 0x21)

This 1 byte register configures the run modes (single shot or continuous) of the sensors.

Figure 27:
Register SENS_RUN

Address 0x21		SENS_RUN		
Bits	Field Name	Default	Access	Field Description
7:2	<reserved>	0b0000000	Read/Write	Keep to 0's
1	H_RUN	0b0	Read/Write	The run mode of the relative humidity sensor 0: Relative humidity sensor operates in single shot mode 1: Relative humidity sensor operates in continuous mode
0	T_RUN	0b0	Read/Write	The run mode of the temperature sensor 0: Temperature sensor operates in single shot mode 1: Temperature sensor operates in continuous mode

Register SENS_START (Address 0x22)

This 1 byte register starts a measurement for the sensors.

Figure 28:
Register SENS_START

Address 0x22		SENS_START		
Bits	Field Name	Default	Access	Field Description
7:2	<reserved>	0b000000	Read/Write	Keep to 0's
1	H_START	0b0	Read/Write	Write a 1 to start a relative humidity sensor measurement Writing 0 has no effect (helps in multiple access)
0	T_START	0b0	Read/Write	Write a 1 to start a temperature sensor measurement Writing 0 has no effect (helps in multiple access)

Register SENS_STOP (Address 0x23)

This 1 byte register stops a continuous measurement for the sensors.

Figure 29:
Register SENS_STOP

Address 0x23		SENS_STOP		
Bits	Field Name	Default	Access	Field Description
7:2	<reserved>	0b000000	Write	Write 0's
1	H_STOP	0b0	Write	Write a 1 to stop a continuous relative humidity sensor measurement Writing 0 has no effect (helps in multiple access)
0	T_STOP	0b0	Write	Write a 1 to stop a continuous temperature sensor measurement Writing 0 has no effect (helps in multiple access)

Register SENS_STAT (Address 0x24)

This 1 byte register indicates the measuring status (idle or active) of the sensors.

Figure 30:
Register SENS_STAT

Address 0x24		SENS_STAT		
Bits	Field Name	Default	Access	Field Description
7:2	<reserved>	0b000000	Read	Write 0's
1	H_STAT	0b0	Read	Indicates the measuring status of the relative humidity sensor 0: Relative humidity sensor is idle (not measuring) 1: Relative humidity sensor is active measuring
0	T_STAT	0b0	Read	Indicates the measuring status of the temperature sensor 0: Temperature sensor is idle (not measuring) 1: Temperature sensor is active measuring

Register T_VAL (Address 0x30)

This 3 byte register contains the last measured temperature data. Furthermore it has a data valid flag and a CRC over the former two. Note that these bytes are double buffered; they are latched in by accessing the first byte, see [The Sensor Readout Registers](#) for details.

See Section [Processing T_VAL and H_VAL](#) for example code of processing this register.

Figure 31:
Register T_VAL

Address 0x30		T_VAL		
Bits	Field Name	Default	Access	Field Description
23:17	T_CRC	-	Read	CRC over T_DATA and T_VALID
16	T_VALID	-	Read	Data valid indication (1 means T_DATA is valid)
15:0	T_DATA	-	Read	Last measured temperature, stored as a little endian 16 bits unsigned value in 1/64 Kelvin

Register H_VAL (Address 0x33)

This 3 byte register contains the last measured relative humidity data. Furthermore it has a data valid flag and a CRC over the former two. Note that these bytes are double buffered; they are latched in by accessing the first byte, see [The Sensor Readout Registers](#) for details.

See [Processing T_VAL and H_VAL](#) for example code of processing this register.

Figure 32:
Register H_VAL

Address 0x33		H_VAL		
Bits	Field Name	Default	Access	Field Description
23:17	H_CRC	-	Read	CRC over H_DATA and H_VALID
16	H_VALID	-	Read	Data valid indication (1 means H_DATA is valid)
15:0	H_DATA	-	Read	Last measured relative humidity, stored as a little endian 16 bits unsigned value in 1/512%RH

Application Information

Typical Application

Figure 33 shows a typical application.

Figure 33:
ENS210 Typical Application

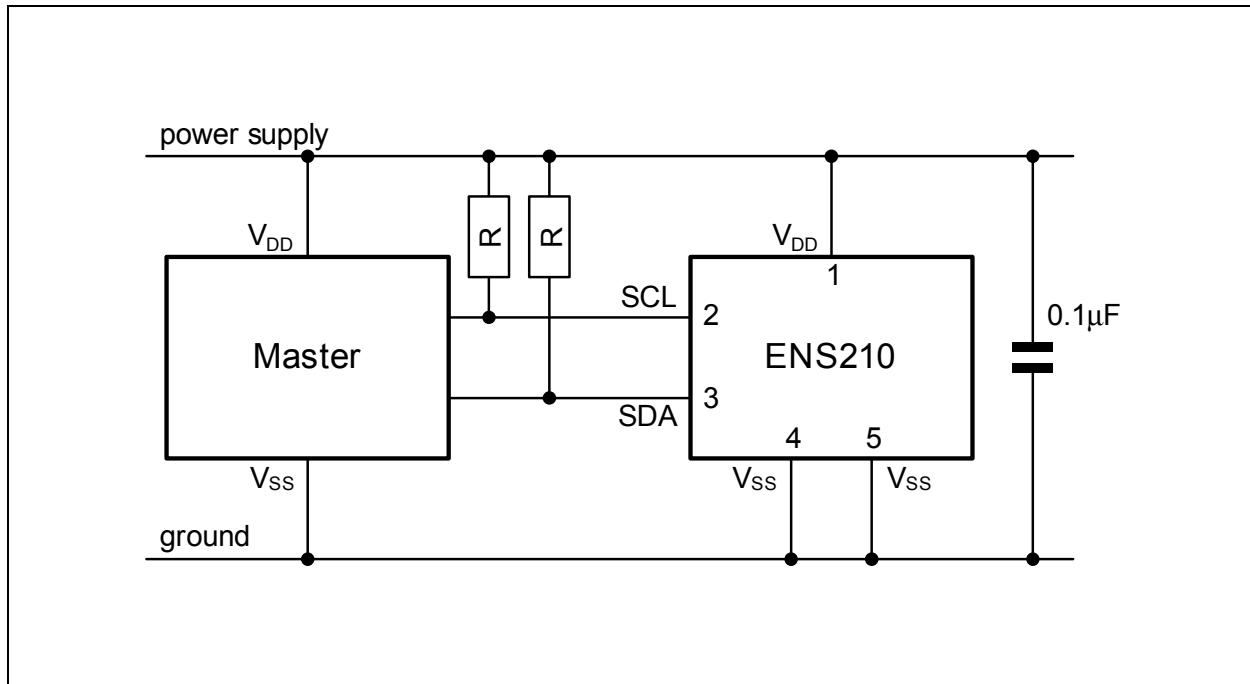

Recommended Operating Conditions

The recommended temperature and relative humidity operating range for the ENS210 is 5°C to 60°C and 20%RH to 80%RH, see Figure 34. Long term exposure outside these recommended operating conditions may temporarily offset the relative humidity readout.

After such exposure, the device will slowly return to its accuracy limits at 25°C (can be matter of hours or weeks, depending on stress conditions). Re-conditioning (bake + hydration) will accelerate kinetics of returning to its accuracy limits at 25°C.

Prolonged exposure to extreme conditions may accelerate drift, which might not be fully recoverable: e.g. after 96h at 85°C/85%RH offset can be around + 6%RH.

Figure 34:
Recommended Operating Conditions

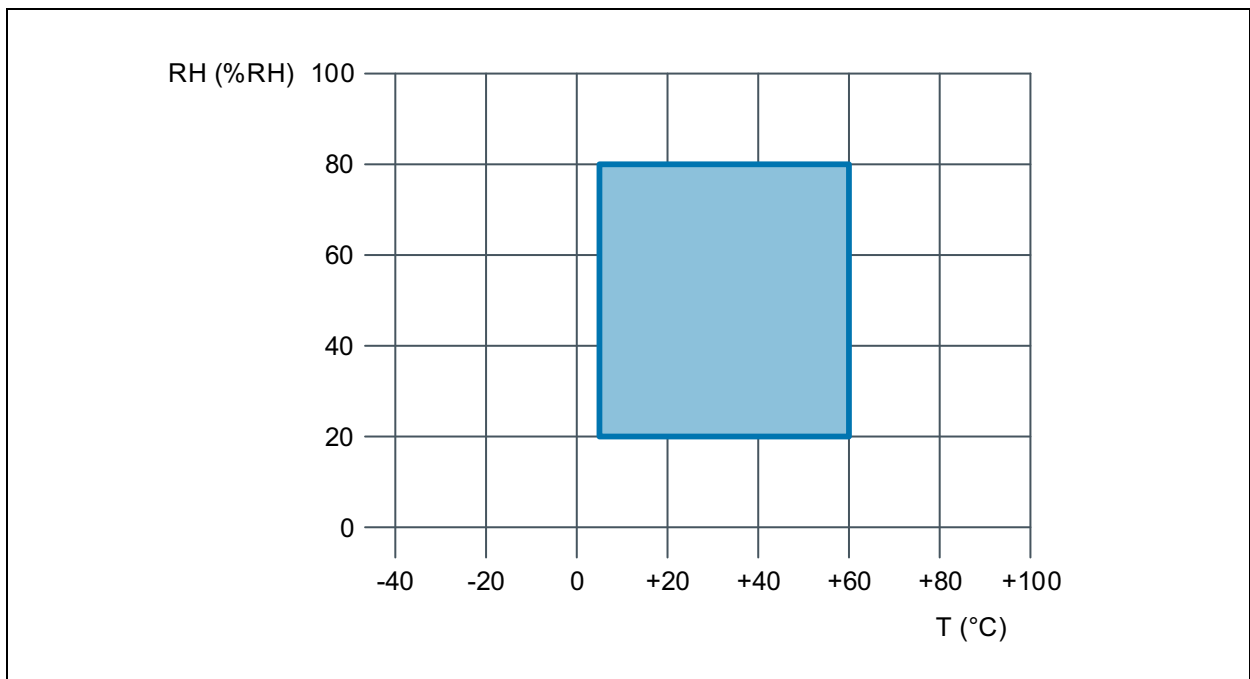

Soldering & Storage Information

Soldering

The ENS210 uses a cavity package. This package can be soldered using a standard reflow process in accordance with IPC/JEDEC J-STD-020D. See picture below.

Figure 35:
Soldering Recommendations

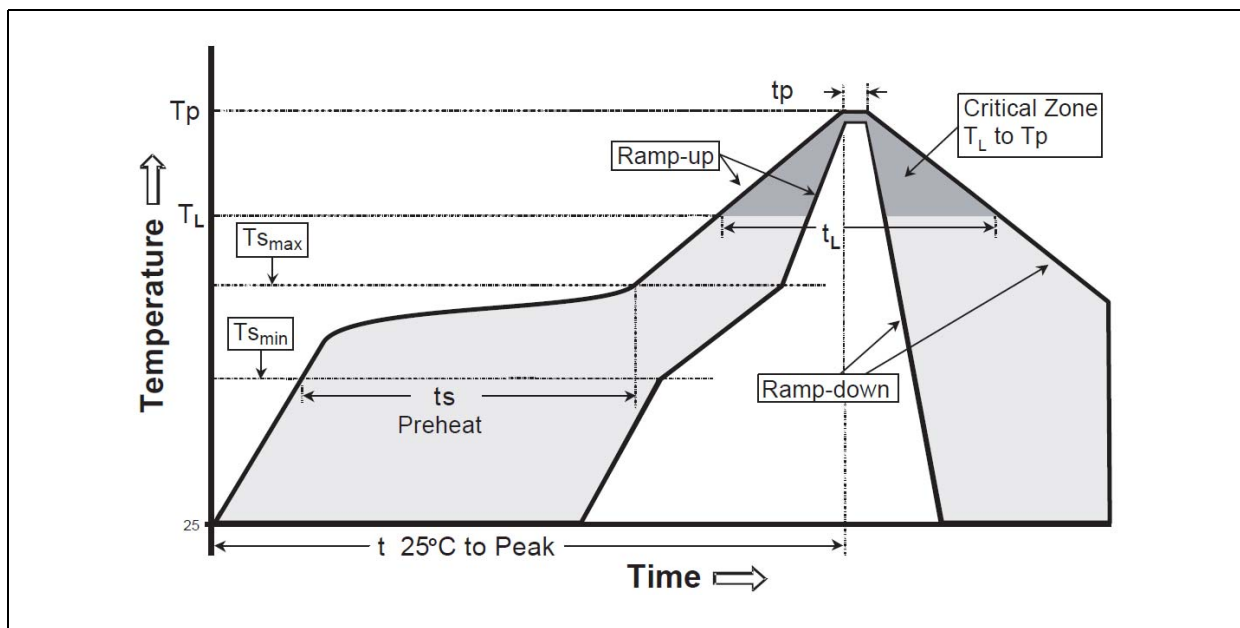

The detailed settings for the reflow profile can be derived from the table below.

Figure 36:
Soldering Recommendations Table

Reflow Profile Settings	
T_p	260°C
t_p (time within 5°C of T_p)	20-40 seconds
T_L	217°C
t_L	60-150 seconds
$T_{S_{max}}$	200°C
$T_{S_{min}}$	150°C
t_s (preheat)	60 to 180 seconds
t 25°C to Peak	8 minutes max.
ramp up	3°C/second max.
ramp down	6°C/second max.

Storage and Handling

The ENS210 moisture sensitivity level is 1 (MSL1), which corresponds to an unlimited out-of-bag lifetime at T = 30°C; RH = 85%RH maximum.

Precautions should be taken to prevent electrostatic discharge (ESD) from damaging the sensor product.

All input and output pins are protected against electrostatic discharge (ESD) under normal handling. When handling ensure that the appropriate precautions are taken as described in JESD625-A or equivalent standards.

The pick-up nozzle of the pick and place machine must be positioned in such a way on the component that it fully covers the cavity of the package, to avoid the leakage of air. Because the ENS210 uses a cavity package, where the sensor is in direct contact with the environment, physical contact with sensor should be prevented at all times. If required, dust particles can be removed by gently blowing air inside the cavity of the package. Do not brush or wipe.

For proper operation of the product, exposure to Volatile Organic Compounds (VOCs) should be avoided or limited as much as possible. During manufacturing, transport and storage, VOCs may originate from out-gassing of glues, adhesive tapes and packaging materials such as bags and foams.

In operation, VOCs might naturally be present in the environment as vapors of, for example, ethanol, acetone and isopropyl alcohol. It is important to realize that some of these contaminants can cause offsets in the sensor reading that may not recover naturally. The same holds for atmospheric pollutants such as ammonia, nitric oxide and chlorine.

Offsets in the sensor reading due to exposure to contaminants may be reversed by applying the recommended Reconditioning Procedure (see below Reconditioning). Direct contact with liquid cleaning agents, or rubbing the surface with brushes or cotton-tip sticks, should be avoided at all times.

If needed, the sensor surface can be cleaned by gently blowing with oil-free compressed air or washing in de-ionized water might recover sensor readings.

The sensor is not damaged by water immersion or condensation. The sensor will recover completely when the water evaporates.

It is advised to avoid exposure to high intensity light for correct sensor readings.

This can be achieved by appropriate mechanical design or usage of a PTFE layer.

In addition it is advised to protect the device from direct exposure to sunlight or other sources of UV radiation.

Reconditioning

The procedures indicated below accelerate the reconditioning of the sensor back to its calibrated state.

After Soldering

After soldering according to [Figure 35](#), RH reading may show an offset of -2%RH compared to its calibrated value. This offset will slowly disappear if the device is exposed to normal ambient conditions (e.g. T = 25°C, RH = 45%RH, for a week). To accelerate return to its initial calibrated state, we recommend to expose devices to 25°C and 75%RH for 12 hours. This would reduce the time it has to recover at normal ambient conditions before usage.

After Extreme Conditions

If the device is exposed to conditions outside the “specified safe operating range” for long time, RH reading may show an offset compared to its calibrated value.

The following procedure accelerates the reconditioning of the sensor back to its calibrated state:

- A mild baking step at 105°C for 12 hours, to evaporate the contaminant.
- A hydration step at 25°C and 75%RH for 12 hours, to rehydrate the sensor material.
- A soak step at normal ambient conditions (e.g. 23°C ± 3°C, 35-55%RH) for 24 hours.

Package Drawings & Markings

The ENS210 has QFN4 package: plastic thermal enhanced very thin small outline package; no leads; 4 terminals; body 2.0 x 2.0 x 0.75mm, see [Figure 38](#).

Figure 38:
Package Outline

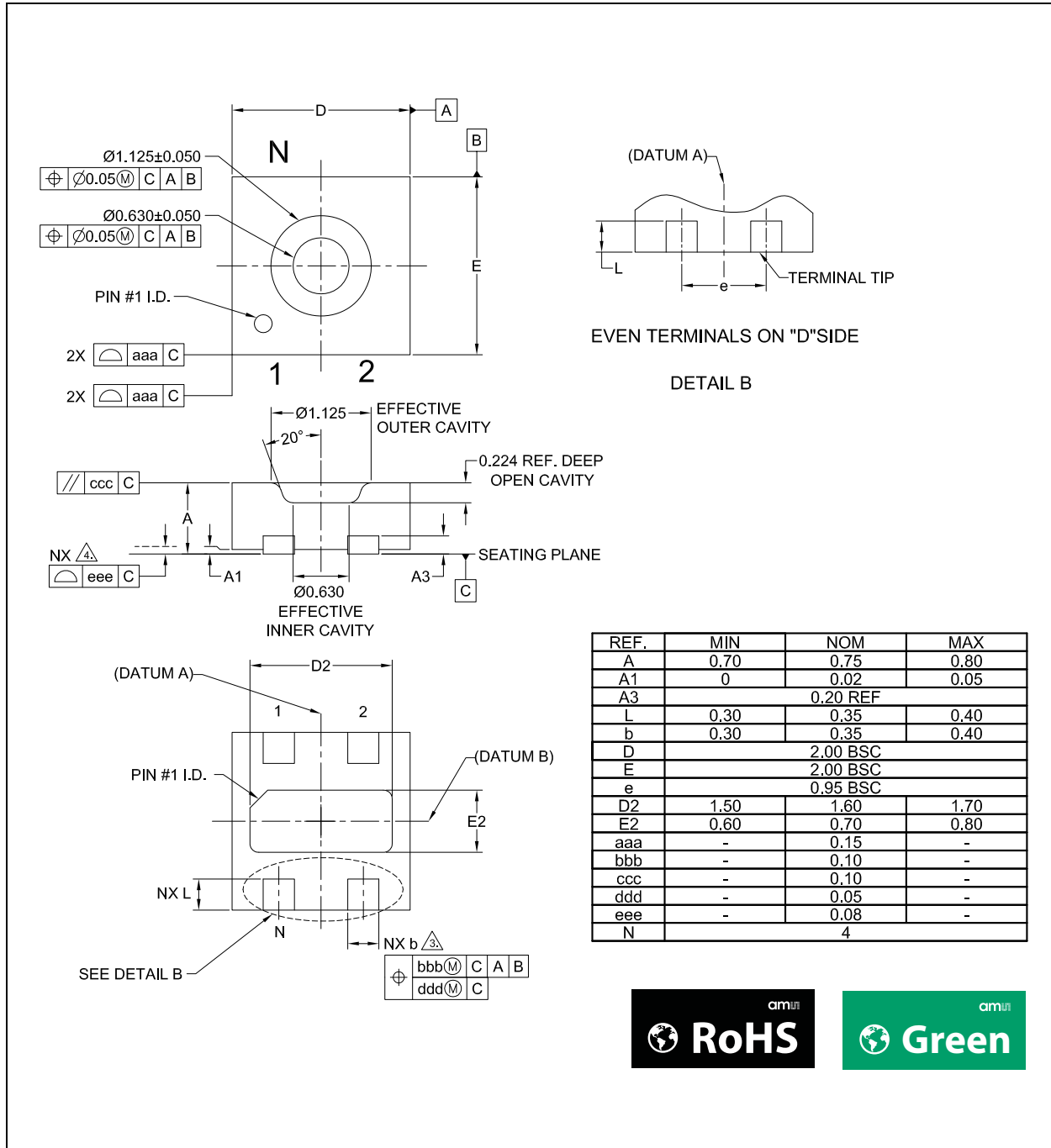

Note(s):

1. Dimensioning and tolerancing conform to ASME Y14.5M-1994.
2. All dimensions are in millimeters. Angles are in degrees.
3. Dimension b applies to metallized terminal and is measured between 0.15mm and 0.30mm from terminal tip.
4. Unilateral coplanarity applies to the exposed heat sink slug as well as the terminal.
5. N is the total number of terminals.



Marking Information

Figure 39:
Marking of ENS210

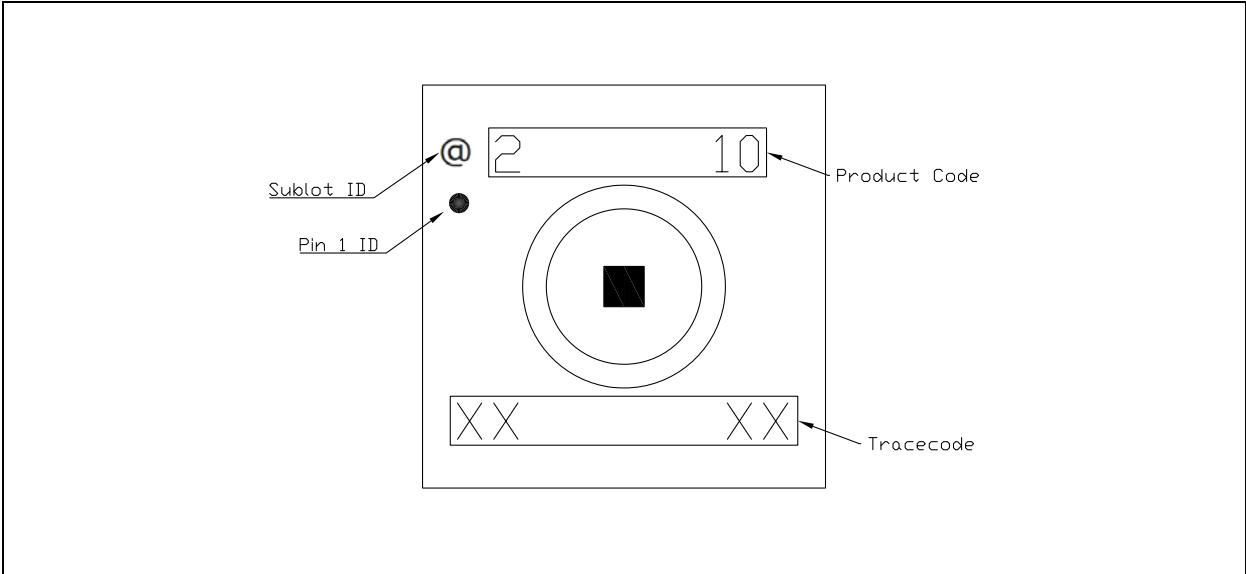

Ordering & Contact Information

Figure 40:
Ordering Information

Ordering Code	Package	Marking	Description	Delivery Form	Delivery Quantity
ENS210-LQFM	QFN4	210	Plastic thermal enhanced very thin small outline package; no leads; 4 terminals; body 2.0 x 2.0 x 0.75 mm	7" Tape & Reel in dry pack	3500 pcs/reel

Buy our products or get free samples online at:

www.ams.com/ICdirect

Technical Support is available at:

www.ams.com/Technical-Support

Provide feedback about this document at:

www.ams.com/Document-Feedback

For further information and requests, e-mail us at:

ams_sales@ams.com

For sales offices, distributors and representatives, please visit:

www.ams.com/contact

Headquarters

ams AG

Tobelbader Strasse 30

8141 Premstaetten

Austria, Europe

Tel: +43 (0) 3136 500 0

Website: www.ams.com

RoHS Compliant & ams Green Statement

RoHS: The term RoHS compliant means that ams AG products fully comply with current RoHS directives. Our semiconductor products do not contain any chemicals for all 6 substance categories, including the requirement that lead not exceed 0.1% by weight in homogeneous materials. Where designed to be soldered at high temperatures, RoHS compliant products are suitable for use in specified lead-free processes.

ams Green (RoHS compliant and no Sb/Br): ams Green defines that in addition to RoHS compliance, our products are free of Bromine (Br) and Antimony (Sb) based flame retardants (Br or Sb do not exceed 0.1% by weight in homogeneous material).

Important Information: The information provided in this statement represents ams AG knowledge and belief as of the date that it is provided. ams AG bases its knowledge and belief on information provided by third parties, and makes no representation or warranty as to the accuracy of such information. Efforts are underway to better integrate information from third parties. ams AG has taken and continues to take reasonable steps to provide representative and accurate information but may not have conducted destructive testing or chemical analysis on incoming materials and chemicals. ams AG and ams AG suppliers consider certain information to be proprietary, and thus CAS numbers and other limited information may not be available for release.

Copyrights & Disclaimer

Copyright ams AG, Tobelbader Strasse 30, 8141 Premstaetten, Austria-Europe. Trademarks Registered. All rights reserved. The material herein may not be reproduced, adapted, merged, translated, stored, or used without the prior written consent of the copyright owner.

Devices sold by ams AG are covered by the warranty and patent indemnification provisions appearing in its General Terms of Trade. ams AG makes no warranty, express, statutory, implied, or by description regarding the information set forth herein. ams AG reserves the right to change specifications and prices at any time and without notice. Therefore, prior to designing this product into a system, it is necessary to check with ams AG for current information. This product is intended for use in commercial applications. Applications requiring extended temperature range, unusual environmental requirements, or high reliability applications, such as military, medical life-support or life-sustaining equipment are specifically not recommended without additional processing by ams AG for each application. This product is provided by ams AG "AS IS" and any express or implied warranties, including, but not limited to the implied warranties of merchantability and fitness for a particular purpose are disclaimed.

ams AG shall not be liable to recipient or any third party for any damages, including but not limited to personal injury, property damage, loss of profits, loss of use, interruption of business or indirect, special, incidental or consequential damages, of any kind, in connection with or arising out of the furnishing, performance or use of the technical data herein. No obligation or liability to recipient or any third party shall arise or flow out of ams AG rendering of technical or other services.

Document Status

Document Status	Product Status	Definition
Product Preview	Pre-Development	Information in this datasheet is based on product ideas in the planning phase of development. All specifications are design goals without any warranty and are subject to change without notice
Preliminary Datasheet	Pre-Production	Information in this datasheet is based on products in the design, validation or qualification phase of development. The performance and parameters shown in this document are preliminary without any warranty and are subject to change without notice
Datasheet	Production	Information in this datasheet is based on products in ramp-up to full production or full production which conform to specifications in accordance with the terms of ams AG standard warranty as given in the General Terms of Trade
Datasheet (discontinued)	Discontinued	Information in this datasheet is based on products which conform to specifications in accordance with the terms of ams AG standard warranty as given in the General Terms of Trade, but these products have been superseded and should not be used for new designs

Revision Information

Changes from 1-00 (2016-Oct-24) to current revision 1-02 (2018-Feb-19)	Page
1-00 (2016-Oct-24) to 1-01 (2018-Jan-26)	
Updated Applications	2
Updated Figure 8 and notes under it	7
Updated Figure 14	11
1-01 (2018-Jan-26) to 1-02 (2018-Feb-19)	
Updated Figure 1	1
Updated Figure 6	5
Updated Figure 8	7
Updated Figure 9	8
Added RH Accuracy at Various Temperatures section	12
Updated text under The I ² C Interface	13
Updated code under Processing T_VAL and H_VAL	20
Updated Figure 40	37

Note(s):

1. Page and figure numbers for the previous version may differ from page and figure numbers in the current revision.
2. Correction of typographical errors is not explicitly mentioned.

Content Guide

1	General Description
1	Key Benefits and Features
2	Applications
2	Block Diagram
3	Pin Assignments
4	Absolute Maximum Ratings
5	Electrical Characteristics
6	I ² C Timing Characteristics
6	Temperature Sensor Characteristics
7	Relative Humidity Sensor Characteristics
8	System Timing Characteristics
9	Functional Description
10	Temperature Sensor
11	Relative Humidity Sensor
12	RH Accuracy at Various Temperatures
13	The I ² C Interface
13	I ² C Operations on Registers
15	The I ² C Slave Address
15	Sensor Control
16	Sensor Timing
18	The Sensor Readout Registers
19	Computing CRC-7
20	Processing T_VAL and H_VAL
22	Reading PART_ID and UID
23	Register Description
23	Register Overview
24	Detailed Register Description
24	Register PART_ID (Address 0x00)
24	Register UID (Address 0x04)
24	Register SYS_CTRL (Address 0x10)
25	Register SYS_STAT (Address 0x11)
25	Register SENS_RUN (Address 0x21)
26	Register SENS_START (Address 0x22)
26	Register SENS_STOP (Address 0x23)
27	Register SENS_STAT (Address 0x24)
27	Register T_VAL (Address 0x30)
28	Register H_VAL (Address 0x33)
29	Application Information
29	Typical Application
30	Recommended Operating Conditions
31	Soldering & Storage Information
31	Soldering
33	Storage and Handling
34	Reconditioning
34	After Soldering
34	After Extreme Conditions

- 35 Package Drawings & Markings**
- 36 Marking Information

- 37 Ordering & Contact Information**
- 38 RoHS Compliant & ams Green Statement**
- 39 Copyrights & Disclaimer**
- 40 Document Status**
- 41 Revision Information**

Компания «Океан Электроники» предлагает заключение долгосрочных отношений при поставках импортных электронных компонентов на взаимовыгодных условиях!

Наши преимущества:

- Поставка оригинальных импортных электронных компонентов напрямую с производств Америки, Европы и Азии, а так же с крупнейших складов мира;
- Широкая линейка поставок активных и пассивных импортных электронных компонентов (более 30 млн. наименований);
- Поставка сложных, дефицитных, либо снятых с производства позиций;
- Оперативные сроки поставки под заказ (от 5 рабочих дней);
- Экспресс доставка в любую точку России;
- Помощь Конструкторского Отдела и консультации квалифицированных инженеров;
- Техническая поддержка проекта, помощь в подборе аналогов, поставка прототипов;
- Поставка электронных компонентов под контролем ВП;
- Система менеджмента качества сертифицирована по Международному стандарту ISO 9001;
- При необходимости вся продукция военного и аэрокосмического назначения проходит испытания и сертификацию в лаборатории (по согласованию с заказчиком);
- Поставка специализированных компонентов военного и аэрокосмического уровня качества (Xilinx, Altera, Analog Devices, Intersil, Interpoint, Microsemi, Actel, Aeroflex, Peregrine, VPT, Syfer, Eurofarad, Texas Instruments, MS Kennedy, Miteq, Cobham, E2V, MA-COM, Hittite, Mini-Circuits, General Dynamics и др.);

Компания «Океан Электроники» является официальным дистрибьютором и эксклюзивным представителем в России одного из крупнейших производителей разъемов военного и аэрокосмического назначения «JONHON», а так же официальным дистрибьютором и эксклюзивным представителем в России производителя высокотехнологичных и надежных решений для передачи СВЧ сигналов «FORSTAR».



JONHON

«JONHON» (основан в 1970 г.)

Разъемы специального, военного и аэрокосмического назначения:

(Применяются в военной, авиационной, аэрокосмической, морской, железнодорожной, горно- и нефтедобывающей отраслях промышленности)

«FORSTAR» (основан в 1998 г.)

ВЧ соединители, коаксиальные кабели, кабельные сборки и микроволновые компоненты:

(Применяются в телекоммуникациях гражданского и специального назначения, в средствах связи, РЛС, а так же военной, авиационной и аэрокосмической отраслях промышленности).



Телефон: 8 (812) 309-75-97 (многоканальный)

Факс: 8 (812) 320-03-32

Электронная почта: ocean@oceanchips.ru

Web: <http://oceanchips.ru/>

Адрес: 198099, г. Санкт-Петербург, ул. Калинина, д. 2, корп. 4, лит. А