

DATA SHEET

CLA4608-085LF: Surface Mount Limiter Diode

Applications

- Low loss, high power limiters
- Receiver protectors

Features

- Low thermal resistance: 29 °C/W
- Typical threshold level: +20 dBm
- Low capacitance: 0.60 pF
- Low profile, ultra-miniature QFN (3-pin, 2 x 2 mm) package (MSL1, 260 °C per JEDEC J-STD-020)



Skyworks Green™ products are compliant with all applicable legislation and are halogen-free. For additional information, refer to *Skyworks Definition of Green™*, document number SQ04-0074.

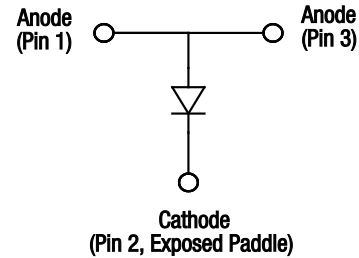

Figure 1. CLA4608-085LF Block Diagram

Description

The CLA4608-085LF is a surface mountable, low capacitance silicon PIN limiter diode designed as a shunt connected PIN diode for high power limiter applications from 10 MHz to over 6 GHz.

Maximum resistance at 10 mA is 1.2 Ω and maximum capacitance at 38 V is 0.65 pF. The combination of low junction capacitance, low parasitic inductance, low thermal resistance, and nominal 7 μm I-region width, makes the CLA4608-085LF useful in large signal limiter applications. The threshold level is +20 dBm, nominal.

A block diagram of the CLA4608-085LF is shown in Figure 1. The absolute maximum ratings of the CLA4608-085LF are provided in Table 1. Electrical specifications are provided in Table 2.

Typical performance characteristics of the CLA4608-085LF are provided in Table 3 and illustrated in Figure 4.

Table 1. CLA4608-085LF Absolute Maximum Ratings

Parameter	Symbol	Minimum	Maximum	Units
Reverse voltage	V_R		180	V
Forward current @ 25 °C	I_F		1.5	A
CW power dissipation @ 85 °C	P_D		2	W
Peak pulse power dissipation @ 85 °C (10% duty cycle)			20	W
Storage temperature	T_{STG}	-65	+200	°C
Junction temperature	T_J		175	°C
Operating temperature	T_A	-40	+150	°C
Electrostatic Discharge: Charged Device Model (CDM), Class 4 Human Body Model (HBM), Class 1B Machine Model (MM), Class A	ESD		1000 500 100	V V V

Note: Exposure to maximum rating conditions for extended periods may reduce device reliability. There is no damage to device with only one parameter set at the limit and all other parameters set at or below their nominal value. Exceeding any of the limits listed here may result in permanent damage to the device.

CAUTION: Although this device is designed to be as robust as possible, Electrostatic Discharge (ESD) can damage this device. This device must be protected at all times from ESD. Static charges may easily produce potentials of several kilovolts on the human body or equipment, which can discharge without detection. Industry-standard ESD precautions should be used at all times.

Table 2. CLA4608-085LF Electrical Specifications (Note 1)
($T_A = +25$ °C Unless Otherwise Noted)

Parameter	Symbol	Test Condition	Min	Typical	Max	Units
Reverse current	I_R	$V_R = 120$ V			10	μ A
Capacitance	C_T	$f = 1$ MHz, $V_R = 38$ V		0.60	0.65	pF
Series resistance	R_S	$f = 500$ MHz, $I_F = 10$ mA		1.0	1.2	Ω
Carrier lifetime	T_L	$I_F = 10$ mA		100		ns
I region width	W			7		μ m
CW thermal resistance	θ_{JC}	Junction-to-case		29		°C/W
Peak thermal resistance	θ_P	Single 1 μ s pulse width, junction-to-case (10% duty cycle)		3		°C/W

Note 1: Performance is guaranteed only under the conditions listed in this Table.

Table 3. Typical Performance @ 25 °C

Part Number	Insertion Loss @ -10 dBm (dB)	Input Power for 1 dB Loss (dBm)	Maximum Pulsed Input Power (dBm)	Output @ Maximum Pulsed Input (dBm)	Maximum CW Input power (W)	Recovery Time (ns)
CLA4608-085LF	0.2	20	59	39	5	100

Notes:

Limiter power results @ 1 GHz for shunt connected, single limiter diode and DC return in 50 Ω line.
 Maximum pulsed power for 1 μ s pulse and 0.1% duty factor with chip @ 25 °C heat sink. Derate linearly to 0 W @ 175 °C.
 Maximum CW input power @ 25 °C heat sink. Derate linearly to 0 W @ 175 °C.
 Recovery time to insertion loss from limiting state.

Functional Description

The PIN limiter diode can be described as an incident power controlled, RF variable resistor. When there is no large input signal present, the impedance of the limiter diode is at its maximum, which produces minimum insertion loss, typically less than 0.2 dB. The presence of a large input signal temporarily forces the impedance of the diode to a much lower value, which produces an impedance mismatch that reflects the majority of the input signal power back towards its source.

During the limiting process, a DC current is generated by the PIN limiter diode. The current is not the result of rectification, but is the result of charge carriers being forced into the I layer by the forward alternations of the large input signal. A complete path must be provided for this current or the diode is not capable of limiting. Therefore, an RF choke or similar structure must be provided to complete the path for DC current flow.

The DC block capacitors shown in Figure 2 are optional; they protect the limiter diode from external DC voltage that may be present in the source or load circuits.

A cross section of the suggested printed circuit board design is shown in Figure 3. The via shown in this view is critical, both for electrical performance and for thermal performance. It is recommended that several vias should be placed under the entire footprint of the exposed paddle (pin 2) to minimize both electrical inductance to the system ground and thermal resistance to the system heat sink.

For more information about the operation of limiter diodes, refer to the Skyworks Application Note, *PIN Limiter Diodes in Receiver Protectors*, document number 200480.

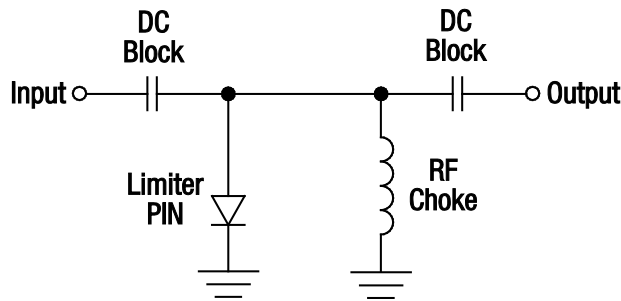

Figure 2. Single Stage Limiter Circuit

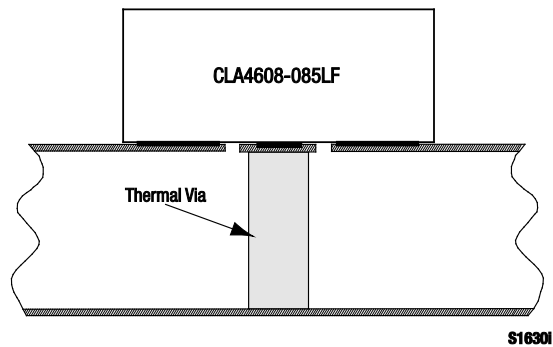

Figure 3. Cross-Sectional View of Suggested Printed Circuit Board

Typical Performance Characteristics

(T_A = 25 °C, Unless Otherwise Noted)

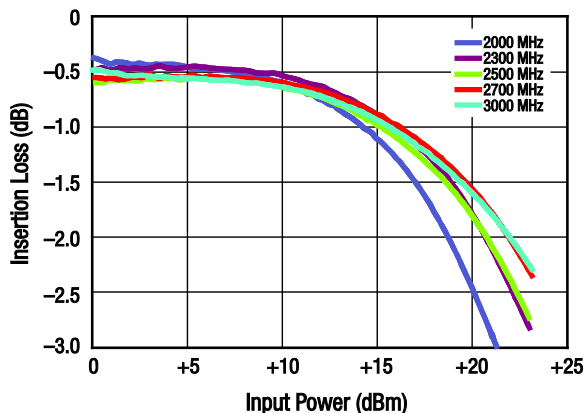

Figure 4. Typical Insertion Loss vs Input Power (Board Loss Included; RF Choke, 10 nH, and 1000 pF DC Blocks Used)

High Power Limiter Design Application

The CLA4608-085LF PIN limiter diode is designed for shunt applications in receiver protection power limiter circuits. Compared to other surface mount packages, the design of the QFN package produces lower thermal resistance and also reduces the effects of the parasitic inductance of the anode bond wires.

A cross-sectional view of the CLA4608-085LF PIN limiter diode is shown in Figure 5. The cathode of the die is soldered directly to the top of the exposed paddle. This paddle is composed of copper, so its thermal resistance is very low.

The copper ground paddle minimizes the total thermal resistance between the I layer, which is the location where most heat is

generated under normal operation, and the surface to which the package is mounted. Minimal thermal resistance between the I layer and the external environment minimizes junction temperature.

The electrically equivalent circuit of the CLA4608-085LF PIN limiter diode is shown in Figure 6. The inductances of pins 1 and 2, as well as the inductances of the bond wires are in series with the input and output transmission lines of the external circuit rather than the portion of the circuit that contains the shunt PIN limiter diode.

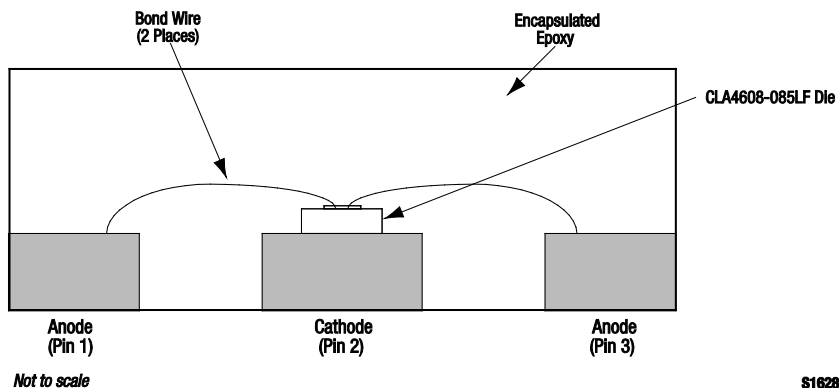

Figure 5. Cross-Sectional View of the CLA4608-085LF

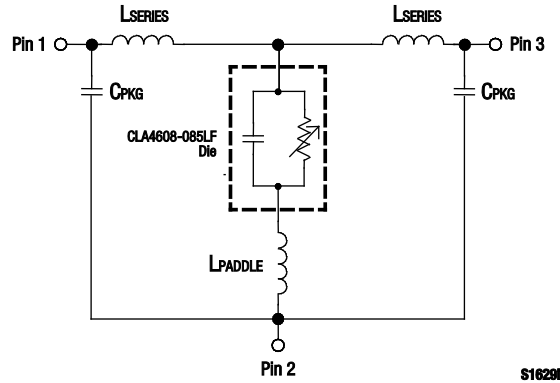

Figure 6. CLA4608-085LF Electrically Equivalent Circuit

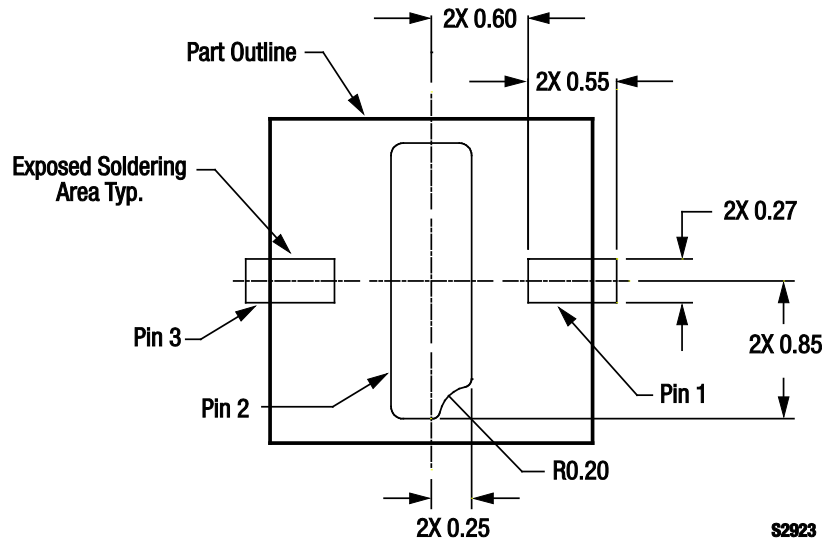

Figure 7. CLA4608-085LF PCB Layout Footprint

Package Dimensions

The PCB layout footprint for the CLA4608-085LF is shown in Figure 7. Typical case markings are shown in Figure 8. Package dimensions for the 3-pin QFN are provided in Figure 9, and Figure 10 provides the tape and reel dimensions.

Package and Handling Information

Instructions on the shipping container label regarding exposure to moisture after the container seal is broken must be followed. Otherwise, problems related to moisture absorption may occur when the part is subjected to high temperature during solder assembly.

The CLA4608-085LF is rated to Moisture Sensitivity Level 1 (MSL1) at 260 °C. It can be used for lead or lead-free soldering. For additional information, refer to the Skyworks Application Note, *Solder Reflow Information*, document number 200164.

Care must be taken when attaching this product, whether it is done manually or in a production solder reflow environment. Production quantities of this product are shipped in a standard tape and reel format.

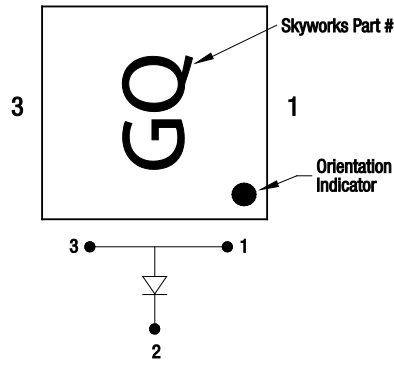
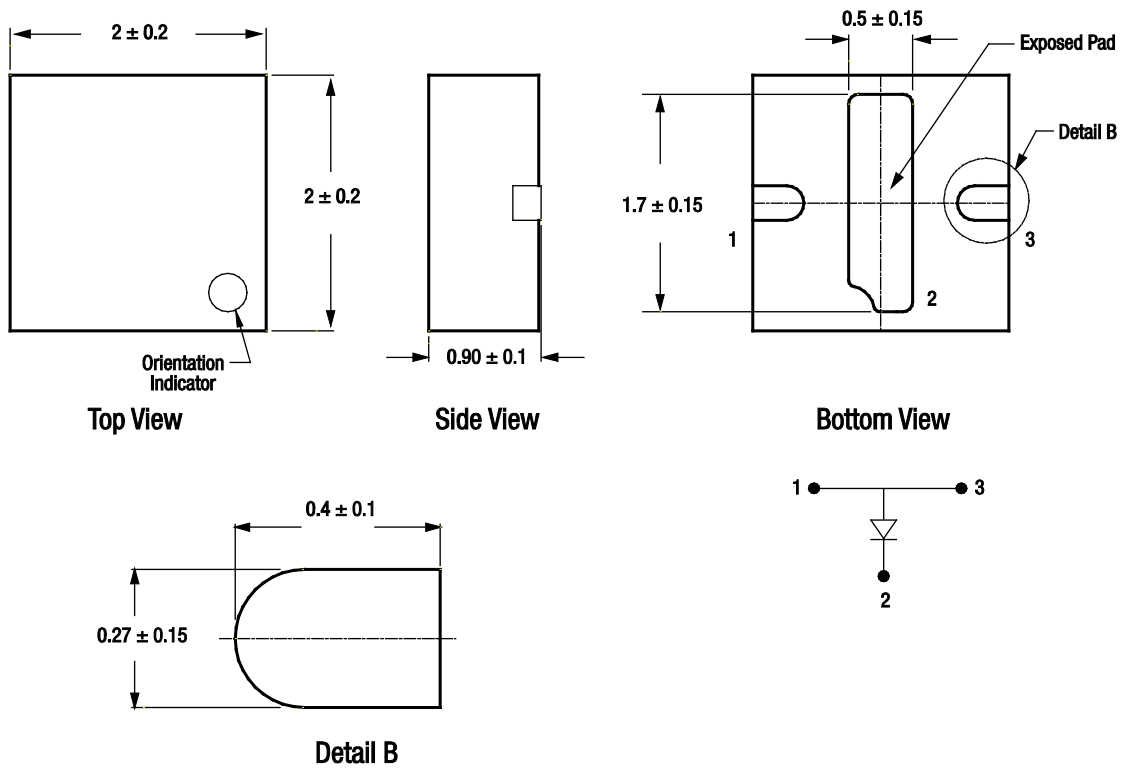

Figure 8. Typical Case Markings (Top View)



All dimensions in millimeters

S1632

Figure 9. CLA4608-085LF QFN Package Dimension Drawing

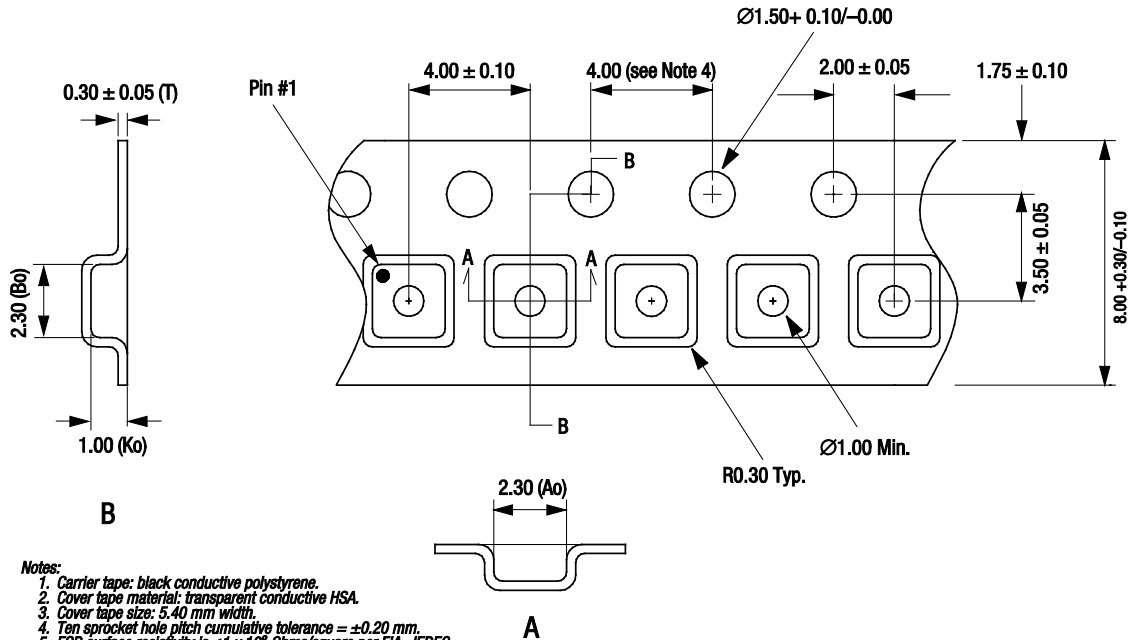

- Notes:
1. Carrier tape: black conductive polystyrene.
 2. Cover tape material: transparent conductive HSA.
 3. Cover tape size: 5.40 mm width.
 4. Ten sprocket hole pitch cumulative tolerance = ± 0.20 mm.
 5. ESD surface resistivity is $< 1 \times 10^6$ Ohms/square per EIA, JEDEC tape and reel specification.
 6. Ao and Bo measurement point to be 0.30 mm from bottom pocket.
 7. All measurements are in millimeters.

S1601

Figure 10. CLA4608-085LF Tape and Reel Dimensions

Ordering Information

Model Name	Manufacturing Part Number
CLA4608-085LF Surface Mount Limiter Diode	CLA4608-085LF

Copyright © 2012, 2013 Skyworks Solutions, Inc. All Rights Reserved.

Information in this document is provided in connection with Skyworks Solutions, Inc. ("Skyworks") products or services. These materials, including the information contained herein, are provided by Skyworks as a service to its customers and may be used for informational purposes only by the customer. Skyworks assumes no responsibility for errors or omissions in these materials or the information contained herein. Skyworks may change its documentation, products, services, specifications or product descriptions at any time, without notice. Skyworks makes no commitment to update the materials or information and shall have no responsibility whatsoever for conflicts, incompatibilities, or other difficulties arising from any future changes.

No license, whether express, implied, by estoppel or otherwise, is granted to any intellectual property rights by this document. Skyworks assumes no liability for any materials, products or information provided hereunder, including the sale, distribution, reproduction or use of Skyworks products, information or materials, except as may be provided in Skyworks Terms and Conditions of Sale.

THE MATERIALS, PRODUCTS AND INFORMATION ARE PROVIDED "AS IS" WITHOUT WARRANTY OF ANY KIND, WHETHER EXPRESS, IMPLIED, STATUTORY, OR OTHERWISE, INCLUDING FITNESS FOR A PARTICULAR PURPOSE OR USE, MERCHANTABILITY, PERFORMANCE, QUALITY OR NON-INFRINGEMENT OF ANY INTELLECTUAL PROPERTY RIGHT; ALL SUCH WARRANTIES ARE HEREBY EXPRESSLY DISCLAIMED. SKYWORKS DOES NOT WARRANT THE ACCURACY OR COMPLETENESS OF THE INFORMATION, TEXT, GRAPHICS OR OTHER ITEMS CONTAINED WITHIN THESE MATERIALS. SKYWORKS SHALL NOT BE LIABLE FOR ANY DAMAGES, INCLUDING BUT NOT LIMITED TO ANY SPECIAL, INDIRECT, INCIDENTAL, STATUTORY, OR CONSEQUENTIAL DAMAGES, INCLUDING WITHOUT LIMITATION, LOST REVENUES OR LOST PROFITS THAT MAY RESULT FROM THE USE OF THE MATERIALS OR INFORMATION, WHETHER OR NOT THE RECIPIENT OF MATERIALS HAS BEEN ADVISED OF THE POSSIBILITY OF SUCH DAMAGE.

Skyworks products are not intended for use in medical, lifesaving or life-sustaining applications, or other equipment in which the failure of the Skyworks products could lead to personal injury, death, physical or environmental damage. Skyworks customers using or selling Skyworks products for use in such applications do so at their own risk and agree to fully indemnify Skyworks for any damages resulting from such improper use or sale.

Customers are responsible for their products and applications using Skyworks products, which may deviate from published specifications as a result of design defects, errors, or operation of products outside of published parameters or design specifications. Customers should include design and operating safeguards to minimize these and other risks. Skyworks assumes no liability for applications assistance, customer product design, or damage to any equipment resulting from the use of Skyworks products outside of stated published specifications or parameters.

Skyworks, the Skyworks symbol, and "Breakthrough Simplicity" are trademarks or registered trademarks of Skyworks Solutions, Inc., in the United States and other countries. Third-party brands and names are for identification purposes only, and are the property of their respective owners. Additional information, including relevant terms and conditions, posted at www.skyworksinc.com, are incorporated by reference.

Компания «Океан Электроники» предлагает заключение долгосрочных отношений при поставках импортных электронных компонентов на взаимовыгодных условиях!

Наши преимущества:

- Поставка оригинальных импортных электронных компонентов напрямую с производств Америки, Европы и Азии, а так же с крупнейших складов мира;
- Широкая линейка поставок активных и пассивных импортных электронных компонентов (более 30 млн. наименований);
- Поставка сложных, дефицитных, либо снятых с производства позиций;
- Оперативные сроки поставки под заказ (от 5 рабочих дней);
- Экспресс доставка в любую точку России;
- Помощь Конструкторского Отдела и консультации квалифицированных инженеров;
- Техническая поддержка проекта, помощь в подборе аналогов, поставка прототипов;
- Поставка электронных компонентов под контролем ВП;
- Система менеджмента качества сертифицирована по Международному стандарту ISO 9001;
- При необходимости вся продукция военного и аэрокосмического назначения проходит испытания и сертификацию в лаборатории (по согласованию с заказчиком);
- Поставка специализированных компонентов военного и аэрокосмического уровня качества (Xilinx, Altera, Analog Devices, Intersil, Interpoint, Microsemi, Actel, Aeroflex, Peregrine, VPT, Syfer, Eurofarad, Texas Instruments, MS Kennedy, Miteq, Cobham, E2V, MA-COM, Hittite, Mini-Circuits, General Dynamics и др.);

Компания «Океан Электроники» является официальным дистрибьютором и эксклюзивным представителем в России одного из крупнейших производителей разъемов военного и аэрокосмического назначения «JONHON», а так же официальным дистрибьютором и эксклюзивным представителем в России производителя высокотехнологичных и надежных решений для передачи СВЧ сигналов «FORSTAR».



JONHON

«JONHON» (основан в 1970 г.)

Разъемы специального, военного и аэрокосмического назначения:

(Применяются в военной, авиационной, аэрокосмической, морской, железнодорожной, горно- и нефтедобывающей отраслях промышленности)

«FORSTAR» (основан в 1998 г.)

ВЧ соединители, коаксиальные кабели, кабельные сборки и микроволновые компоненты:

(Применяются в телекоммуникациях гражданского и специального назначения, в средствах связи, РЛС, а так же военной, авиационной и аэрокосмической отраслях промышленности).



Телефон: 8 (812) 309-75-97 (многоканальный)

Факс: 8 (812) 320-03-32

Электронная почта: ocean@oceanchips.ru

Web: <http://oceanchips.ru/>

Адрес: 198099, г. Санкт-Петербург, ул. Калинина, д. 2, корп. 4, лит. А