

FEATURES

- Outstanding gain linearity**
- Ultrahigh gain, 5000 V/mV min**
- Low V_{OS} over temperature, 55 μV max**
- TCV_{OS} , 0.3 $\mu\text{V}/^\circ\text{C}$ max**
- High PSRR, 3 $\mu\text{V}/\text{V}$ max**
- Low power consumption, 60 mW max**
- Available in die form**

PIN CONNECTIONS

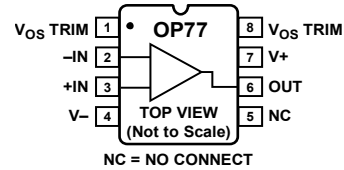

Figure 1. 8-Pin Hermetic CERDIP_Q-8 (Z Suffix)

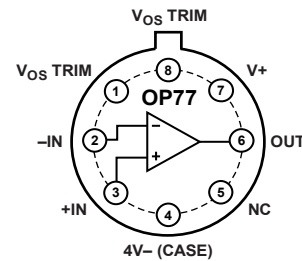

Figure 2. TO-99 (J Suffix)

GENERAL DESCRIPTION

The **OP77** has outstanding gain of 10,000,000 or more that is maintained over the full 10 V output range. This gain-linearity eliminates incorrectable system nonlinearities common in previous monolithic op amps and provides superior performance in high closed-loop gain applications. Low initial V_{OS} drift and rapid stabilization time, combined with only 50 mW of power consumption, are significant improvements over previous designs. These characteristics, plus the TCV_{OS} of 0.3 $\mu\text{V}/^\circ\text{C}$ maximum and the low V_{OS} of 25 μV maximum, eliminates

the need for V_{OS} adjustment and increases system accuracy over temperature.

A PSRR of 3 $\mu\text{V}/\text{V}$ (110 dB) and CMRR of 1.0 $\mu\text{V}/\text{V}$ maximum virtually eliminate errors caused by power supply drifts and common-mode signals. This combination of outstanding characteristics makes the **OP77** ideally suited for high resolution instrumentation and other tight error budget systems.

TABLE OF CONTENTS

Features	1	Thermal Resistance	6
Pin Connections	1	ESD Caution.....	6
General Description	1	Typical Performance Characteristics	7
Revision History	2	Test Circuits.....	10
Specifications.....	3	Applications.....	11
Electrical Specifications.....	3	Precision Current Sinks.....	12
Wafer Test Limits.....	4	Outline Dimensions	15
Typical Electrical Characteristics	5	Ordering Guide	16
Absolute Maximum Ratings.....	6		

REVISION HISTORY

10/15—Rev. F to Rev. G

Changes to Features Section and General Description Section.....	1
Changes to Note 1, Ordering Guide.....	16

3/15—Rev. E to Rev. F

Updated Outline Dimensions	15
Changes to Ordering Guide	16

4/10—Rev. D to Rev. E

Removed Figure 33 and Two Subsequent Paragraphs.....	12
--	----

6/09—Rev. C to Rev. D

Changes to Figure 1 and Figure 2.....	1
Changes to Table 1.....	3
Removed Endnote 1 and Endnote 2 in Table 3	4
Changes to Figure 16.....	9
Changes to Figure 31 and Figure 32.....	12
Changes to Figure 38.....	14
Moved Figure 39	14

10/02—Rev. B to Rev. C

Edits to Specifications	2
Figure 2 Caption Changed	10
Figure 3 Caption Changed	10
Edits to Figure 10.....	11
Updated Outline Dimensions.....	15

2/02—Rev. A to Rev. B

Remove 8-Lead SO PIN Connection Diagrams.....	1
Changes to Absolute Maximum Rating.....	2
Remove OP77B column from Specifications.....	2
Remove OP77B column from Electrical Characteristics	3, 5
Remove OP77G column from Wafer Test Limits.....	6
Remove OP77G column from Typical Electrical Characteristics	6

SPECIFICATIONS

ELECTRICAL SPECIFICATIONS

@ $V_S = \pm 15\text{ V}$, $T_A = 25^\circ\text{C}$, unless otherwise noted.

Table 1.

Parameter	Symbol	Conditions	OP77E			OP77F			Unit
			Min	Typ	Max	Min	Typ	Max	
INPUT OFFSET VOLTAGE	V_{OS}		10	25		20	60		μV
LONG-TERM STABILITY ¹	V_{OS}/time		0.3			0.4			$\mu\text{V}/\text{Mo}$
INPUT OFFSET CURRENT	I_{OS}		0.3	1.5		0.3	2.8		nA
INPUT BIAS CURRENT	I_B		-0.2	+1.2	+2.0	-0.2	+1.2	+2.8	nA
INPUT NOISE VOLTAGE ²	$e_{n\text{-p-p}}$	0.1 Hz to 10 Hz	0.35	0.6		0.38	0.65		$\mu\text{V}_{\text{p-p}}$
INPUT NOISE VOLTAGE DENSITY	e_n	$f_0 = 10\text{ Hz}$ $f_0 = 100\text{ Hz}^2$ $f_0 = 1000\text{ Hz}$	10.3 10.0 9.6	18.0 13.0 11.0		10.5 10.2 9.8	20.0 13.5 11.5		$\text{nV}/\sqrt{\text{Hz}}$
INPUT NOISE CURRENT ²	$i_{n\text{-p-p}}$	0.1 Hz to 10 Hz	14	30		15	35		$\text{pA}_{\text{p-p}}$
INPUT NOISE CURRENT DENSITY	i_n	$f_0 = 10\text{ Hz}$ $f_0 = 100\text{ Hz}^2$ $f_0 = 1000\text{ Hz}$	0.32 0.14 0.12	0.80 0.23 0.17		0.35 0.15 0.13	0.90 0.27 0.18		$\text{pA}/\sqrt{\text{Hz}}$
INPUT RESISTANCE Differential Mode ³ Common Mode	R_{IN} R_{INCM}		26	45 200		18.5	45 200		$\text{M}\Omega$ $\text{G}\Omega$
INPUT VOLTAGE RANGE	IVR		± 13	± 14		± 13	± 14		V
COMMON-MODE REJECTION RATIO	CMRR	$V_{CM} = \pm 13\text{ V}$	0.1	1.0		0.1	1.6		$\mu\text{V}/\text{V}$
POWER SUPPLY REJECTION RATIO	PSRR	$V_S = \pm 3\text{ V to } \pm 18\text{ V}$	0.7	3.0		0.7	3.0		$\mu\text{V}/\text{V}$
LARGE-SIGNAL VOLTAGE GAIN	A_{VO}	$R_L \geq 2\text{ k}\Omega$ $V_O = \pm 10\text{ V}$	5000	12,000		2000	6000		V/mV
OUTPUT VOLTAGE SWING	V_O	$R_L \geq 10\text{ k}\Omega$ $R_L \geq 2\text{ k}\Omega$ $R_L \geq 1\text{ k}\Omega$	± 13.5 ± 12.5 ± 12.0	± 14.0 ± 13.0 ± 12.5		± 13.5 ± 12.5 ± 12.0	± 14.0 ± 13.0 ± 12.5		V
SLEW RATE ²	SR	$R_L \geq 2\text{ k}\Omega$	0.1	0.3		0.1	0.3		$\text{V}/\mu\text{s}$
CLOSED-LOOP BANDWIDTH ²	BW	$A_{VCL} + 1$	0.4	0.6		0.4	0.6		MHz
OPEN-LOOP OUTPUT RESISTANCE	R_O		60			60			Ω
POWER CONSUMPTION	P_d	$V_S = \pm 15\text{ V}$, no load $V_S = \pm 3\text{ V}$, no load	50 3.5	60 4.5		50 3.5	60 4.5		mW
OFFSET ADJUSTMENT RANGE		$R_p = 20\text{ kn}$	± 3			± 3			mV

¹ Long-term input offset voltage stability refers to the averaged trend line of V_{OS} vs. time over extended periods after the first 30 days of operation. Excluding the initial hour of operation, changes in V_{OS} during the first 30 operating days are typically $2.5\ \mu\text{V}$.

² Sample tested.

³ Guaranteed by design.

@ $V_S = \pm 15\text{ V}$, $-25^\circ\text{C} \leq T_A \leq +85^\circ\text{C}$ for OP77FJ and OP77E/OP77F, unless otherwise noted.

Table 2.

Parameter	Symbol	Conditions	OP77E			OP77F			Unit
			Min	Typ	Max	Min	Typ	Max	
INPUT OFFSET VOLTAGE	V_{OS}			10	45		20	100	μV
AVERAGE INPUT OFFSET VOLTAGE DRIFT ¹	TCV_{OS}			0.1	0.3		0.2	0.6	$\mu\text{V}/^\circ\text{C}$
INPUT OFFSET CURRENT	I_{OS}			0.5	2.2		0.5	4.5	nA
AVERAGE INPUT OFFSET CURRENT DRIFT ²	TCI_{OS}			1.5	4.0		1.5	85	$\text{pA}/^\circ\text{C}$
INPUT BIAS CURRENT	I_B		-0.2	+2.4	+4.0	-0.2	+2.4	+6.0	nA
AVERAGE INPUT BIAS CURRENT DRIFT ²	TCI_B			8	40		15	60	$\text{pA}/^\circ\text{C}$
INPUT VOLTAGE RANGE	IVR		± 13.0	± 13.5		± 13.0	± 13.5		V
COMMON-MODE REJECTION RATIO	CMRR	$V_{CM} = \pm 13\text{ V}$		0.1	1.0		0.1	3.0	pV/V
POWER SUPPLY REJECTION RATIO	PSRR	$V_S = \pm 3\text{ V to } \pm 18\text{ V}$		1.0	3.0		1.0	5.0	$\mu\text{V}/\text{V}$
LARGE-SIGNAL VOLTAGE GAIN	A_{VO}	$R_L \geq 2\text{ k}\Omega$ $V_O = \pm 10\text{ V}$	2000	6000		1000	4000		V/mV
OUTPUT VOLTAGE SWING	V_O	$R_L \geq 2\text{ k}\Omega$	± 12	± 13.0		± 12	± 13.0		V
POWER CONSUMPTION	P_d	$V_S = \pm 15\text{ V}$, no load		60	75		60	75	mW

¹ OP77E: TCV_{OS} is 100% tested on J and Z packages.

² Guaranteed by end-point limits.

WAFER TEST LIMITS

@ $V_S = \pm 15\text{ V}$, $T_A = 25^\circ\text{C}$, for OP77NBC devices, unless otherwise noted.

Table 3.

Parameter	Symbol	Conditions	OP77NBC Limit	Unit
INPUT OFFSET VOLTAGE	V_{OS}		40	$\mu\text{V max}$
INPUT OFFSET CURRENT	I_{OS}		2.0	nA max
INPUT BIAS CURRENT	I_B		± 2	nA max
INPUT RESISTANCE Differential Mode	R_{IN}		26	$\text{M}\Omega\text{ min}$
INPUT VOLTAGE RANGE	IVR		± 13	V min
COMMON-MODE REJECTION RATIO	CMRR	$V_{CM} = \pm 13\text{ V}$	1	$\mu\text{V}/\text{V max}$
POWER SUPPLY REJECTION RATIO	PSRR	$V_S = \pm 3\text{ V to } \pm 18\text{ V}$	3	$\mu\text{V}/\text{V max}$
OUTPUT VOLTAGE SWING	V_O	$R_L = 10\text{ k}\Omega$ $R_L = 2\text{ k}\Omega$ $R_L = 1\text{ k}\Omega$	± 13.5 ± 12.5 ± 12.0	V min
LARGE-SIGNAL VOLTAGE GAIN	A_{VO}	$R_L = 2\text{ k}\Omega$ $V_O = \pm 10\text{ V}$	2000	$\text{V}/\text{mV min}$
DIFFERENTIAL INPUT VOLTAGE			± 30	V max
POWER CONSUMPTION	P_d	$V_O = 0\text{ V}$	60	mW max

TYPICAL ELECTRICAL CHARACTERISTICS

@ $V_S = \pm 15\text{ V}$, $T_A = 25^\circ\text{C}$, unless otherwise noted.

Table 4.

Parameter	Symbol	Conditions	OP77NBC Limit	Unit
AVERAGE INPUT OFFSET VOLTAGE DRIFT	TCV_{OS}	$R_S = 50\ \Omega$	0.1	$\mu\text{V}/^\circ\text{C}$
NULLED INPUT OFFSET VOLTAGE DRIFT	TCV_{OSn}	$R_S = 50\ \Omega$, $R_P = 20\ \text{k}\Omega$	0.1	$\mu\text{V}/^\circ\text{C}$
AVERAGE INPUT OFFSET CURRENT DRIFT	TCI_{OS}		0.5	$\text{pA}/^\circ\text{C}$
SLEW RATE	SR	$R_L \geq 2\ \text{k}\Omega$	0.3	$\text{V}/\mu\text{s}$
BANDWIDTH	BW	$A_{VCL} + 1$	0.6	MHz

ABSOLUTE MAXIMUM RATINGS

Table 5.

Parameter ¹	Rating
Supply Voltage	±22 V
Differential Input Voltage	±30 V
Input Voltage ²	±22 V
Output Short-Circuit Duration	Indefinite
Storage Temperature Range	–65°C to +150°C
Operating Temperature Range	–25°C to +85°C
Junction Temperature (T _J)	–65°C to +150°C
Lead Temperature (Soldering, 60 sec)	300°C

¹ Absolute Maximum Ratings apply to both dice and packaged parts, unless otherwise noted.

² For supply voltages less than ±22 V, the absolute maximum input voltage is equal to the supply voltage.

Stresses at or above those listed under Absolute Maximum Ratings may cause permanent damage to the product. This is a stress rating only; functional operation of the product at these or any other conditions above those indicated in the operational section of this specification is not implied. Operation beyond the maximum operating conditions for extended periods may affect product reliability.

THERMAL RESISTANCE

Table 6.

Package Type	θ _{JA} ¹	θ _{JC}	Unit
8-Pin TO-99 H-08 (J Suffix)	150	18	°C/W
8-Lead Hermetic CERDIP Q-8 (Z Suffix)	148	16	°C/W

¹ θ_{JA} is specified for worst-case mounting conditions, i.e., θ_{JA} is specified for a device in socket for the TO-99 and CERDIP packages.

ESD CAUTION



ESD (electrostatic discharge) sensitive device. Charged devices and circuit boards can discharge without detection. Although this product features patented or proprietary protection circuitry, damage may occur on devices subjected to high energy ESD. Therefore, proper ESD precautions should be taken to avoid performance degradation or loss of functionality.

TYPICAL PERFORMANCE CHARACTERISTICS

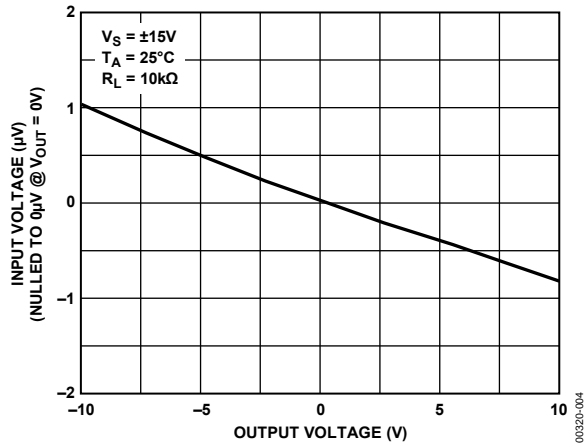

Figure 3. Gain Linearity (Input Voltage vs. Output Voltage)

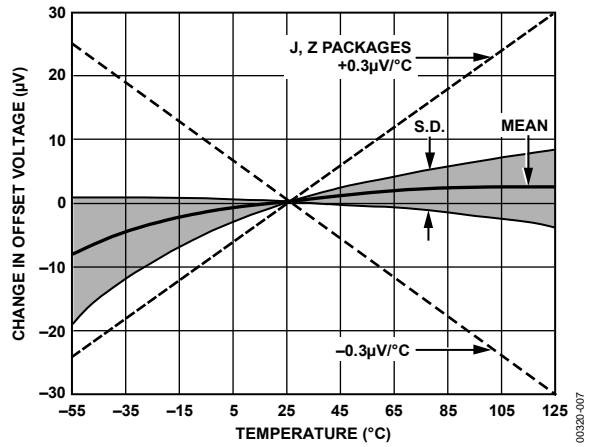

Figure 6. Untrimmed Offset Voltage vs. Temperature

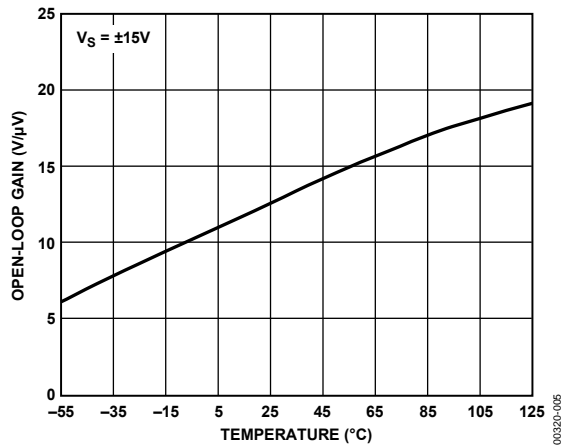

Figure 4. Open-Loop Gain vs. Temperature

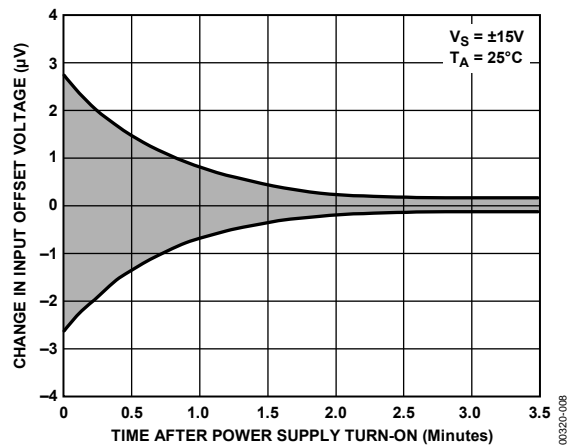

Figure 7. Warm-Up Drift

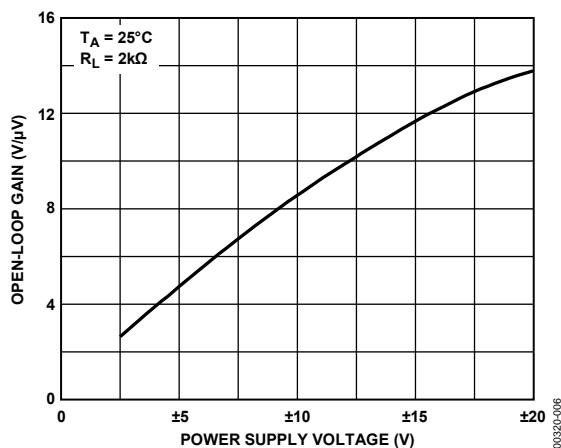

Figure 5. Open-Loop Gain vs. Power Supply Voltage

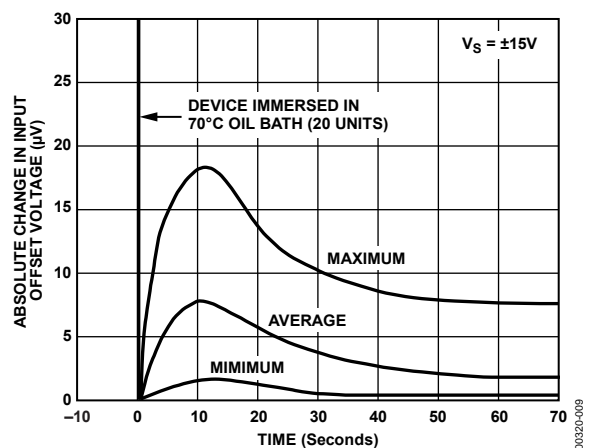

Figure 8. Offset Voltage Change Due to Thermal Shock

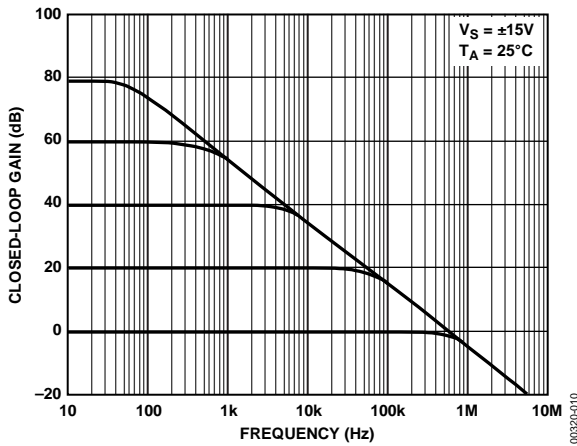

Figure 9. Closed-Loop Response for Various Gain Configurations

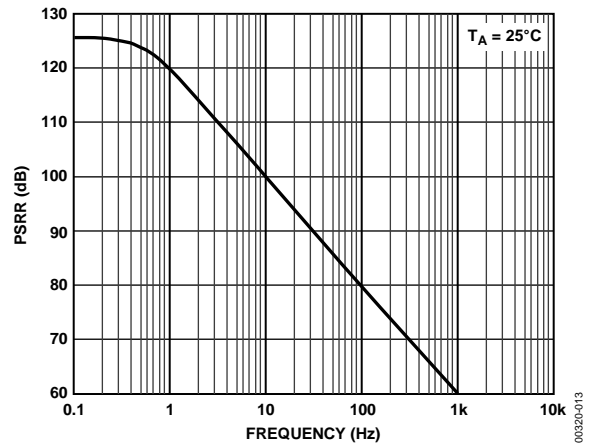

Figure 12. PSRR vs. Frequency

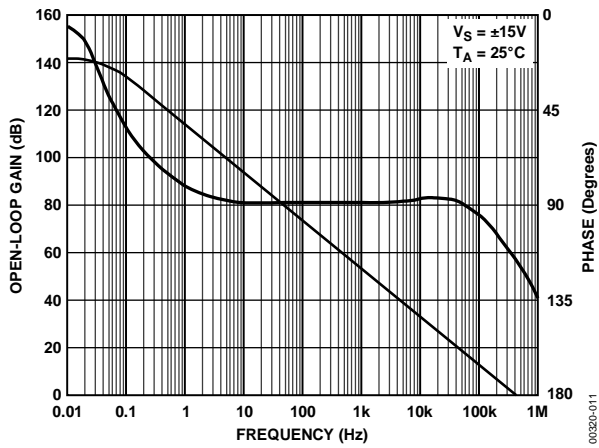

Figure 10. Open-Loop Gain/Phase Response

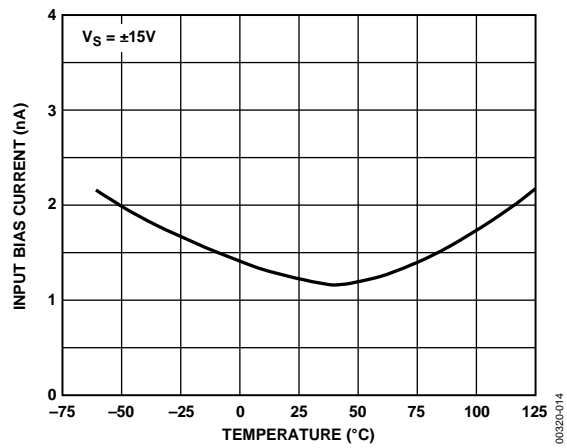

Figure 13. Input Bias Current vs. Temperature

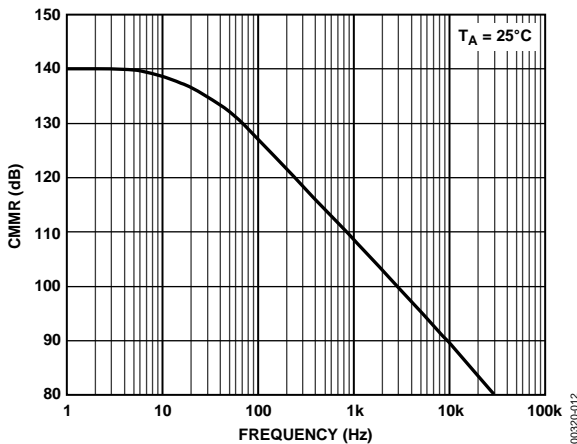

Figure 11. CMRR vs. Frequency

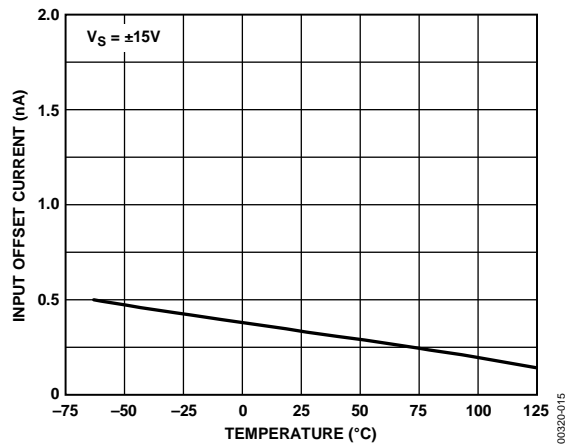

Figure 14. Input Offset Current vs. Temperature

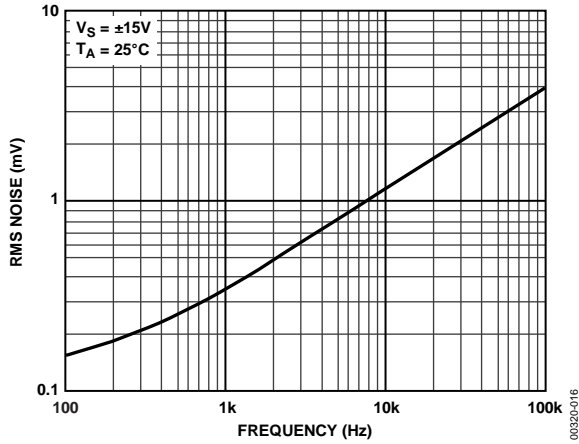

Figure 15. Input Wideband Noise vs. Bandwidth (0.1 Hz to Frequency Indicated)

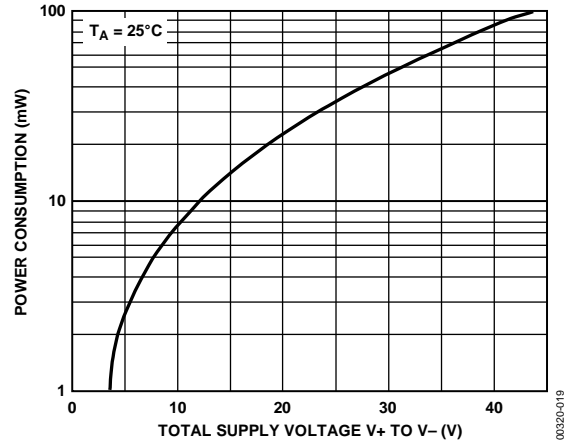

Figure 18. Power Consumption vs. Power Supply

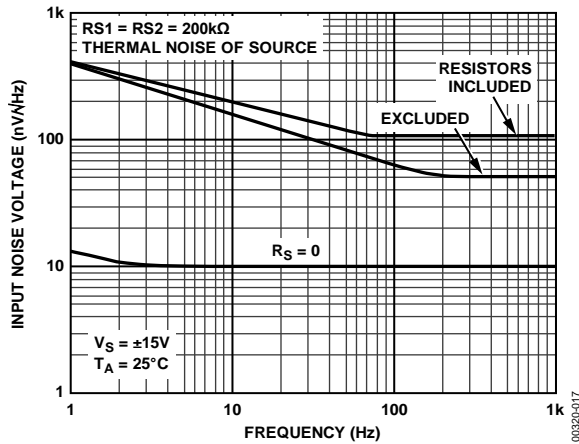

Figure 16. Total Input Noise Voltage vs. Frequency

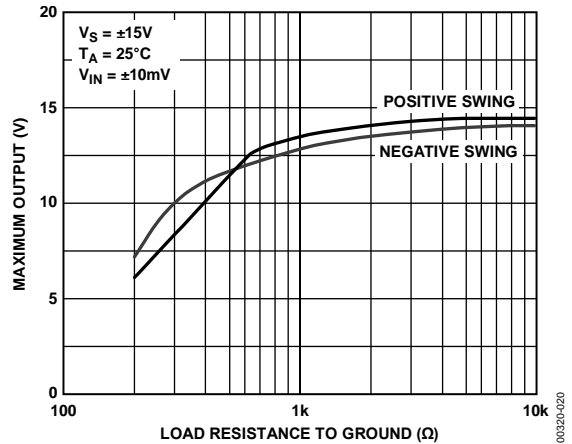

Figure 19. Maximum Output Voltage vs. Load Resistance

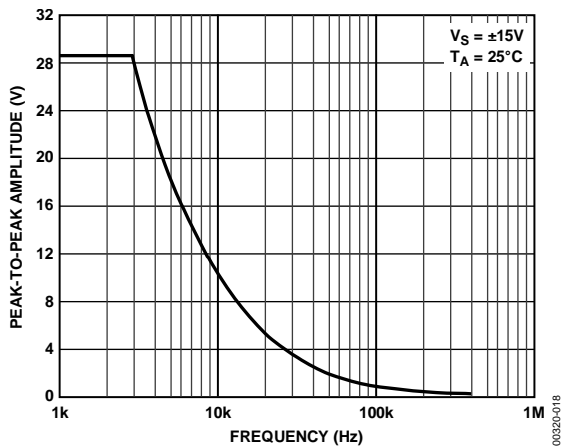

Figure 17. Maximum Output Swing vs. Frequency

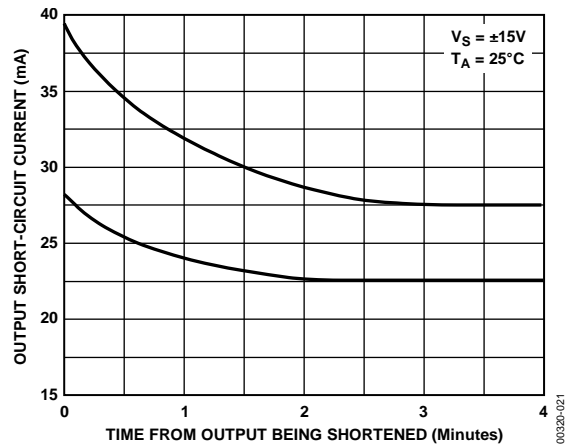

Figure 20. Output Short-Circuit Current vs. Time

TEST CIRCUITS

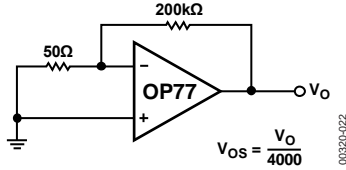

Figure 21. Typical Offset Voltage Test Circuit

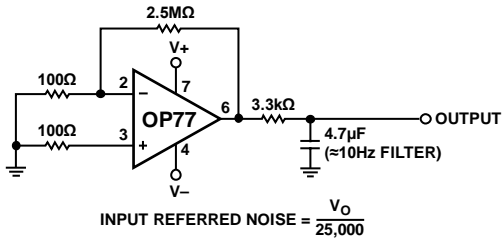

Figure 22. Typical Low-Frequency Noise Test Circuit

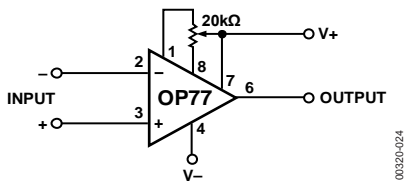
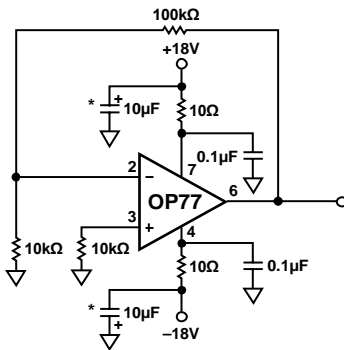
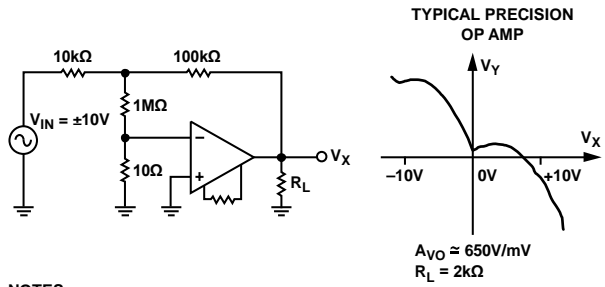

Figure 23. Optional Offset Nulling Circuit



NOTES
*1 PER BOARD

Figure 24. Burn-In Circuit



NOTES
1. GAIN NOT CONSISTANT. CAUSES NONLINEAR ERRORS.
2. A_{VO} SPEC IS ONLY PART OF THE SOLUTION.
3. CHECK SPECIFICATION TABLE 1 AND TABLE 2 FOR PERFORMANCE.

Figure 25. Open-Loop Gain Linearity

Actual open-loop voltage gain can vary greatly at various output voltages. All automated testers use endpoint testing and therefore only show the average gain. This causes errors in high closed-loop gain circuits. Because this is difficult for manufacturers to test, users should make their own evaluations. This simple test circuit makes it easy. An ideal op amp would show a horizontal scope trace.

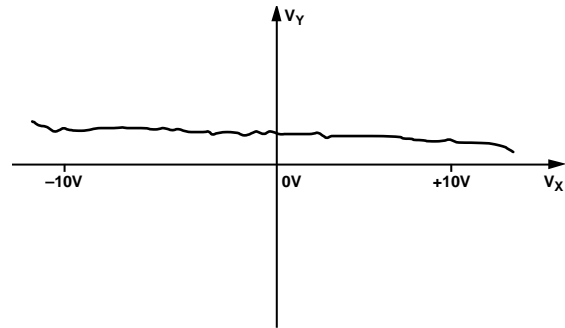

Figure 26. Output Gain Linearity Trace

This is the output gain linearity trace for the new OP77. The output trace is virtually horizontal at all points, assuring extremely high gain accuracy. The average open-loop gain is truly impressive—approximately 10,000,000.

APPLICATIONS

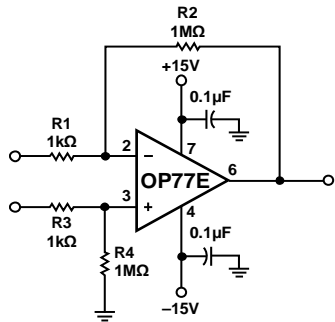

Figure 27. Precision High-Gain Differential Amplifier

The high gain, gain linearity, CMRR, and low TCV_{OS} of the OP77 make it possible to obtain performance not previously available in single-stage, very high-gain amplifier applications.

For best CMR, $\frac{R1}{R2}$ must equal $\frac{R3}{R4}$. In this example, with a 10 mV differential signal, the maximum errors are as listed in Table 7.

Table 7. Maximum Errors

Type	Amount
Common-Mode Voltage	0.01%/V
Gain Linearity, Worst Case	0.02%
TCV _{OS}	0.003%/°C
TCl _{OS}	0.008%/°C

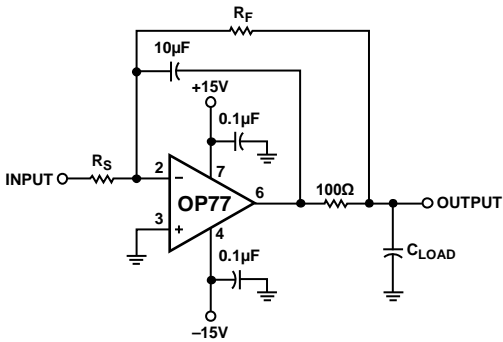

Figure 28. Isolating Large Capacitive Loads

This circuit reduces maximum slew rate but allows driving capacitive loads of any size without instability. Because the boom resistor is inside the feedback loop, its effect on output impedance is reduced to insignificance by the high open-loop gain of the OP77.

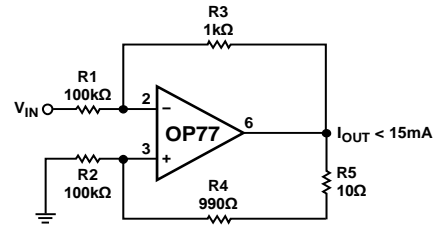
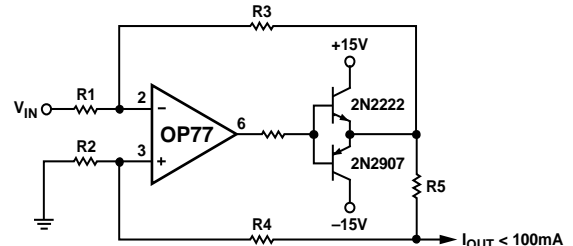

Figure 29. Basic Current Source



$$I_{OUT} = V_{IN} \left(\frac{R3}{R1 - R5} \right)$$

$$\text{GIVEN } R3 = R4 + R5, R1 = R2$$

Figure 30. 100 mA Current Source

These current sources can supply both positive and negative current into a grounded load.

Note that

$$Z_O = \frac{R5 \left(\frac{R4}{R2} + 1 \right)}{\frac{R5 + R4}{R2} \frac{R3}{R1}}$$

And that for Z_O to be infinite $\frac{R5 + R4}{R2}$ must = $\frac{R3}{R1}$

PRECISION CURRENT SINKS

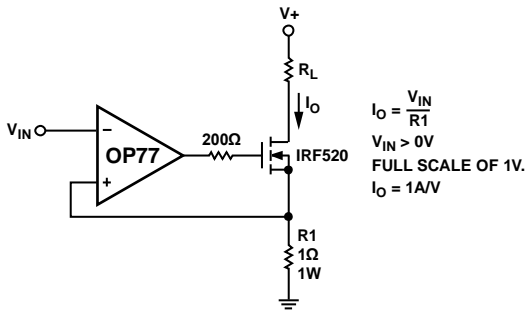

Figure 31. Positive Current Sink

$$I_o = \frac{V_{IN}}{R_1}$$

$V_{IN} > 0V$
 FULL SCALE OF 1V.
 $I_o = 1A/V$

00320-032

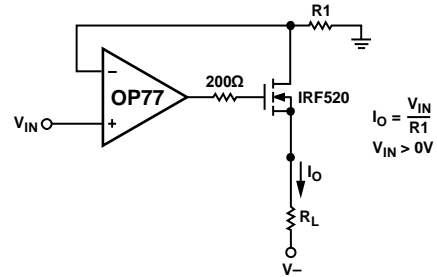

Figure 32. Positive Current Source

$$I_o = \frac{V_{IN}}{R_1}$$

$V_{IN} > 0V$

00320-033

The simple high-current sinks, shown Figure 31 and Figure 32, require the load to float between the power supply and the sink.

In these circuits, the high gain, high CMRR, and low TCV_{OS} of the OP77 ensure high accuracy.

The high gain and low TCV_{OS} ensure accurate operation with inputs from microvolts to volts. In Figure 33, the signal always appears as a common-mode signal to the op amps. The OP77EZ CMRR of 1 μV/V ensures errors of less than 2 ppm.

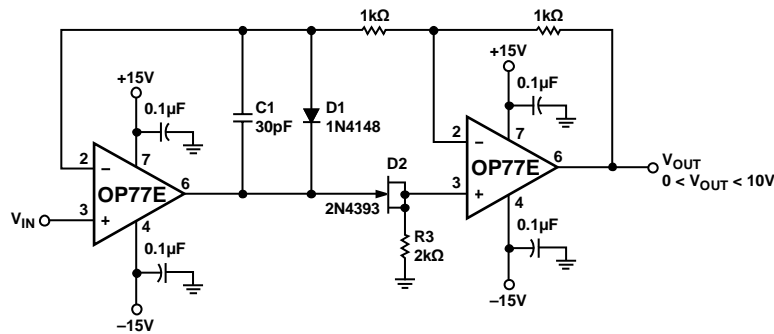

Figure 33. Precision Absolute Value Amplifier

00320-035

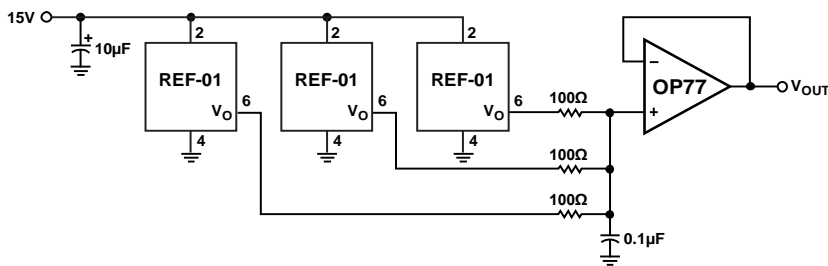

Figure 34. Low Noise Precision Reference

00320-036

Figure 34 relies upon low TCV_{OS} of the OP77 and noise combined with very high CMRR to provide precision buffering of the averaged REF-01 voltage outputs.

In Figure 35, C_H must be of polystyrene, Teflon*, or polyethylene to minimize dielectric absorption and leakage. The droop rate is determined by the size of C_H and the bias current of the AD820.

*Teflon is a registered trademark of the Dupont Company

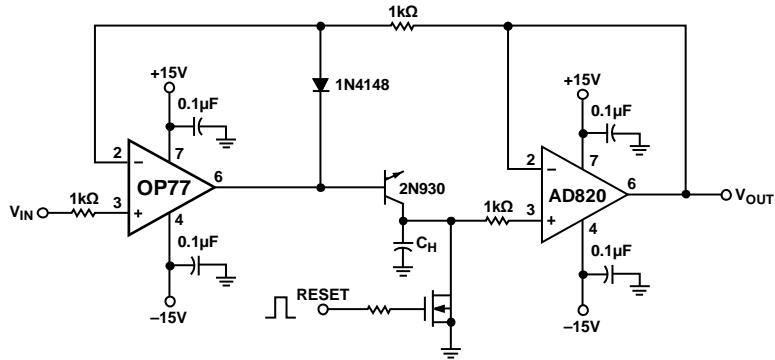

Figure 35. Precision Positive Peak Detector

00320-037

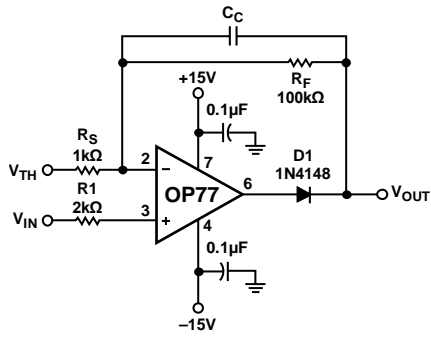

Figure 36. Precision Threshold Detector/Amplifier

When $V_{IN} < V_{TH}$, amplifier output swings negative, reversing the biasing diode D1. $V_O = V_{TH}$ if $R_L = \infty$ when $V_{IN} > V_{TH}$, the loop closes,

$$V_O = V_{TH} + (V_{IN} - V_{TH}) \left(1 + \frac{R_F}{R_S} \right)$$

C_C is selected to smooth the response of the loop.

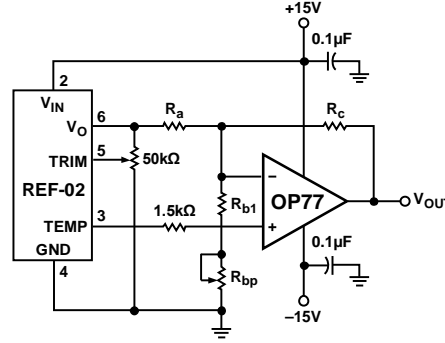
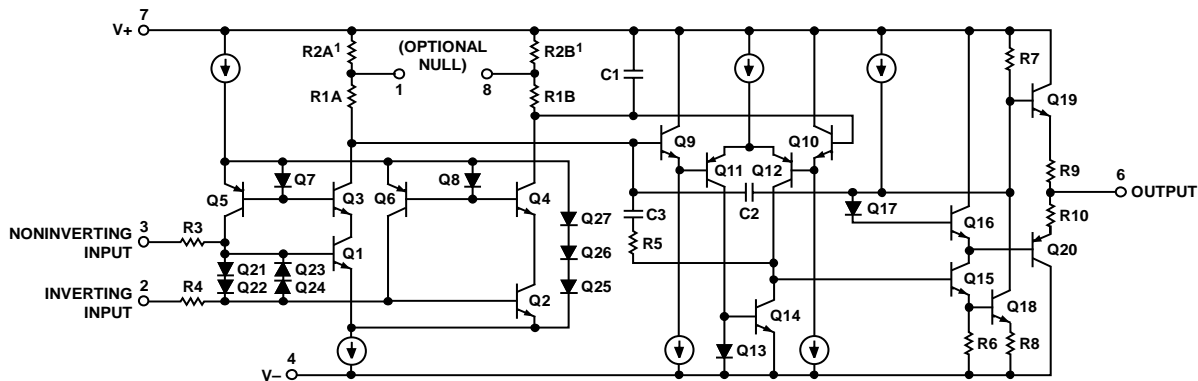

Figure 37. Precision Temperature Sensor

Table 8. Resistor Values

TCV _{OUT} Slope (S)	10 mV/°C	100 mV/°C	10 mV/°F
Temperature Range	-55°C to +125°C	-55°C to +125°C	-67°F to +257°C
Output Voltage Range	-0.55 V to +1.25 V	-5.5 V to +12.5V	-0.67 V to +2.57V
Zero-Scale	0 V @ 0°C	0 V @ 0°C	0 V @ 0°F
R _a (±1% Resistor)	9.09 kΩ	15 kΩ	7.5 kΩ
R _{b1} (±1% Resistor)	1.5 kΩ	1.82 kΩ	1.21 kΩ
R _{bp} (Potentiometer)	200 Ω	500 Ω	200 Ω
R _c (±1% Resistor)	5.11 kΩ	84.5 kΩ	8.25 kΩ



¹R2A AND R2B ARE ELECTRONICALLY ADJUSTED ON CHIP AT FACTORY.

Figure 38. Simplified Schematic

OUTLINE DIMENSIONS

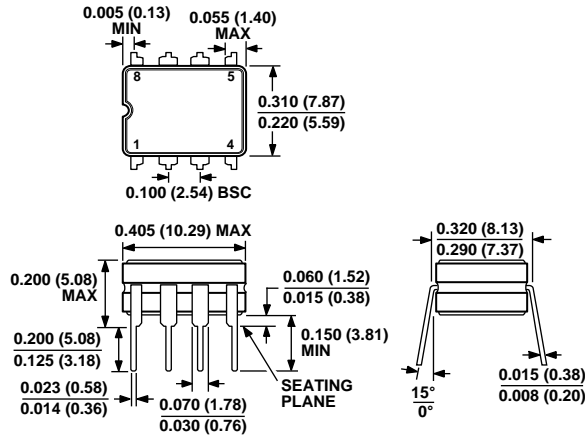

CONTROLLING DIMENSIONS ARE IN INCHES; MILLIMETER DIMENSIONS (IN PARENTHESES) ARE ROUNDED-OFF INCH EQUIVALENTS FOR REFERENCE ONLY AND ARE NOT APPROPRIATE FOR USE IN DESIGN.

Figure 39. 8-Lead Ceramic Dual In-Line Package [CERDIP] (Q-8)

Dimensions shown in inches and (millimeters)

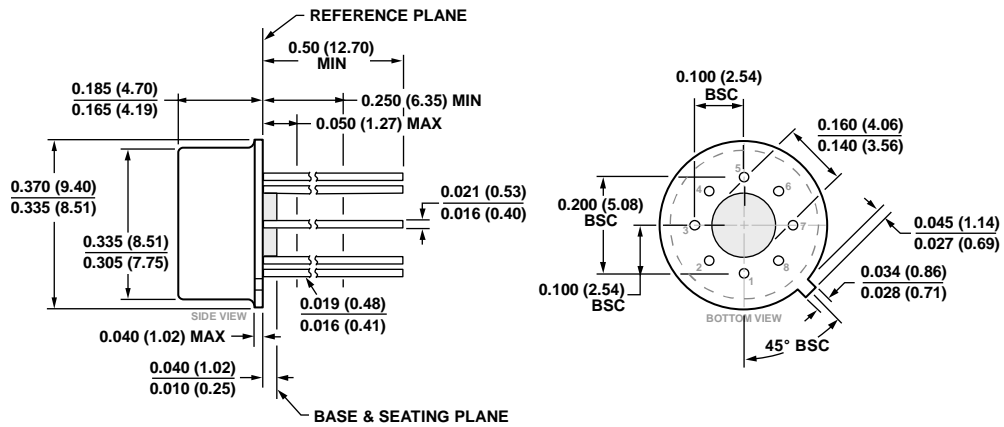

COMPLIANT TO JEDEC STANDARDS MO-002-AK
CONTROLLING DIMENSIONS ARE IN INCHES; MILLIMETER DIMENSIONS (IN PARENTHESES) ARE ROUNDED-OFF INCH EQUIVALENTS FOR REFERENCE ONLY AND ARE NOT APPROPRIATE FOR USE IN DESIGN.

Figure 40. 8-Pin Metal Header [TO-99] (H-08)

Dimensions shown in inches and (millimeters)

01-15-2015-B

ORDERING GUIDE

Model ¹	Temperature Range	Package Description	Package Option
OP77FJZ	-25°C to +85°C	8-Pin Metal Header [TO-99]	H-08 (J Suffix)
OP77EZ	-25°C to +85°C	8-Lead Ceramic Dual In-Line Package [CERDIP]	Q-8 (Z Suffix)
OP77FZ	-25°C to +85°C	8-Lead Ceramic Dual In-Line Package [CERDIP]	Q-8 (Z Suffix)
OP77NBC		Die	

¹ The OP77FJZ is a RoHS compliant part.

Компания «Океан Электроники» предлагает заключение долгосрочных отношений при поставках импортных электронных компонентов на взаимовыгодных условиях!

Наши преимущества:

- Поставка оригинальных импортных электронных компонентов напрямую с производств Америки, Европы и Азии, а так же с крупнейших складов мира;
- Широкая линейка поставок активных и пассивных импортных электронных компонентов (более 30 млн. наименований);
- Поставка сложных, дефицитных, либо снятых с производства позиций;
- Оперативные сроки поставки под заказ (от 5 рабочих дней);
- Экспресс доставка в любую точку России;
- Помощь Конструкторского Отдела и консультации квалифицированных инженеров;
- Техническая поддержка проекта, помощь в подборе аналогов, поставка прототипов;
- Поставка электронных компонентов под контролем ВП;
- Система менеджмента качества сертифицирована по Международному стандарту ISO 9001;
- При необходимости вся продукция военного и аэрокосмического назначения проходит испытания и сертификацию в лаборатории (по согласованию с заказчиком);
- Поставка специализированных компонентов военного и аэрокосмического уровня качества (Xilinx, Altera, Analog Devices, Intersil, Interpoint, Microsemi, Actel, Aeroflex, Peregrine, VPT, Syfer, Eurofarad, Texas Instruments, MS Kennedy, Miteq, Cobham, E2V, MA-COM, Hittite, Mini-Circuits, General Dynamics и др.);

Компания «Океан Электроники» является официальным дистрибьютором и эксклюзивным представителем в России одного из крупнейших производителей разъемов военного и аэрокосмического назначения «JONHON», а так же официальным дистрибьютором и эксклюзивным представителем в России производителя высокотехнологичных и надежных решений для передачи СВЧ сигналов «FORSTAR».



JONHON

«JONHON» (основан в 1970 г.)

Разъемы специального, военного и аэрокосмического назначения:

(Применяются в военной, авиационной, аэрокосмической, морской, железнодорожной, горно- и нефтедобывающей отраслях промышленности)

«FORSTAR» (основан в 1998 г.)

ВЧ соединители, коаксиальные кабели, кабельные сборки и микроволновые компоненты:

(Применяются в телекоммуникациях гражданского и специального назначения, в средствах связи, РЛС, а так же военной, авиационной и аэрокосмической отраслях промышленности).



Телефон: 8 (812) 309-75-97 (многоканальный)

Факс: 8 (812) 320-03-32

Электронная почта: ocean@oceanchips.ru

Web: <http://oceanchips.ru/>

Адрес: 198099, г. Санкт-Петербург, ул. Калинина, д. 2, корп. 4, лит. А