

General-purpose single operational amplifier

Datasheet - production data

N
DIP8
(plastic package)

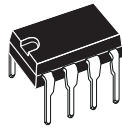

D
S08
(plastic micropackage)

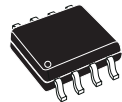

Pin connections
(top view)

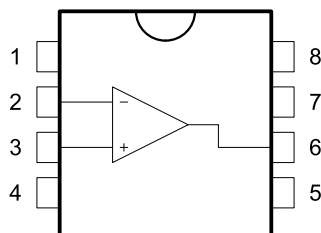

- 1 - Offset null 1
- 2 - Inverting input
- 3 - Non-inverting input
- 4 - V_{CC}^-
- 5 - Offset null 2
- 6 - Output
- 7 - V_{CC}^+
- 8 - N.C.

Features

- Large input voltage range
- No latch-up
- High gain
- Short-circuit protection
- No frequency compensation required
- Same pin configuration as the UA709

Applications

- Summing amplifiers
- Voltage followers
- Integrators
- Active filters
- Function generators

Description

The UA741 is a high performance monolithic operational amplifier constructed on a single silicon chip. It is intended for a wide range of analog applications.

The high gain and wide range of operating voltages provide superior performances in integrators, summing amplifiers and general feedback applications. The internal compensation network (6 dB/octave) ensures stability in closed-loop circuits.

Contents

1	Schematic diagram	3
2	Absolute maximum ratings and operating conditions	4
3	Electrical characteristics	5
4	Package information	7
	4.1 DIP8 package information	8
	4.2 SO8 package information	9
5	Ordering information	10
6	Revision history	10

1 Schematic diagram

Figure 1. Schematic diagram

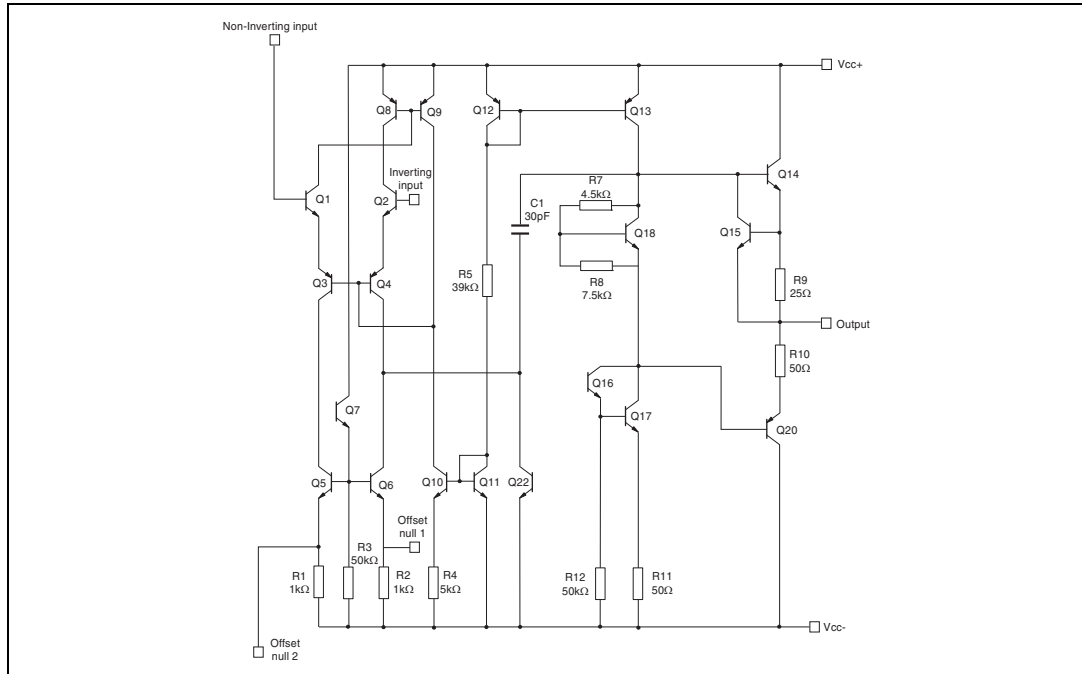

2 Absolute maximum ratings and operating conditions

Table 1. Absolute maximum ratings

Symbol	Parameter	Value	Unit
V_{CC}	Supply voltage	± 22	V
V_{id}	Differential input voltage	± 30	
V_i	Input voltage	± 15	
	Output short-circuit duration	Infinite	
R_{thja}	Thermal resistance junction to ambient		$^{\circ}\text{C}/\text{W}$
	DIP8	85	
	SO8	125	
R_{thjc}	Thermal resistance junction to case		
	DIP8	41	
	SO8	40	
ESD	HBM: human body model ⁽¹⁾		V
	DIP package	500	
	SO package	400	
	MM: machine model ⁽²⁾	100	
	CDM: charged device model ⁽³⁾	1.5	kV
T_{stg}	Storage temperature range	-65 to +150	$^{\circ}\text{C}$

- Human body model: a 100 pF capacitor is charged to the specified voltage, then discharged through a 1.5k Ω resistor between two pins of the device. This is done for all couples of connected pin combinations while the other pins are floating.
- Machine model: a 200 pF capacitor is charged to the specified voltage, then discharged directly between two pins of the device with no external series resistor (internal resistor < 5 Ω). This is done for all couples of connected pin combinations while the other pins are floating.
- Charged device model: all pins and the package are charged together to the specified voltage and then discharged directly to the ground through only one pin. This is done for all pins.

Table 2. Operating conditions

Symbol	Parameter	UA741I	UA741C	Unit
V_{CC}	Supply voltage	5 to 40		V
V_{icm}	Common mode input voltage range	± 12		
T_{oper}	Operating free air temperature range	-40 to +105	0 to +70	$^{\circ}\text{C}$

3 Electrical characteristics

**Table 3. Electrical characteristics at $V_{CC} = \pm 15\text{ V}$, $T_{amb} = 25\text{ °C}$
(unless otherwise specified)**

Symbol	Parameter	Min.	Typ.	Max.	Unit
V_{io}	Input offset voltage ($R_s \leq 10\text{ k}\Omega$) $T_{amb} = +25\text{ °C}$ $T_{min} \leq T_{amb} \leq T_{max}$		1	5 6	mV
I_{io}	Input offset current $T_{amb} = +25\text{ °C}$ $T_{min} \leq T_{amb} \leq T_{max}$		2	30 70	nA
I_{ib}	Input bias current $T_{amb} = +25\text{ °C}$ $T_{min} \leq T_{amb} \leq T_{max}$		10	100 200	
A_{vd}	Large signal voltage gain ($V_o = \pm 10\text{ V}$, $R_L = 2\text{ k}\Omega$) $T_{amb} = +25\text{ °C}$ $T_{min} \leq T_{amb} \leq T_{max}$	50 25	200		V/mV
SVR	Supply voltage rejection ratio ($R_s \leq 10\text{ k}\Omega$) $T_{amb} = +25\text{ °C}$ $T_{min} \leq T_{amb} \leq T_{max}$	77 77	90		dB
I_{CC}	Supply current, no load $T_{amb} = +25\text{ °C}$ $T_{min} \leq T_{amb} \leq T_{max}$		1.7	2.8 3.3	mA
V_{icm}	Input common mode voltage range $T_{amb} = +25\text{ °C}$ $T_{min} \leq T_{amb} \leq T_{max}$	± 12 ± 12			V
CMR	Common mode rejection ratio ($R_S \leq 10\text{ k}\Omega$) $T_{amb} = +25\text{ °C}$ $T_{min} \leq T_{amb} \leq T_{max}$	70 70	90		dB
I_{OS}	Output short circuit current	10	25	40	mA
$\pm V_{opp}$	Output voltage swing $T_{amb} = +25\text{ °C}$ $T_{min} \leq T_{amb} \leq T_{max}$				V
	$R_L = 10\text{ k}\Omega$ $R_L = 2\text{ k}\Omega$ $R_L = 10\text{ k}\Omega$ $R_L = 2\text{ k}\Omega$	12 10 12 10	14 13		
SR	Slew rate $V_i = \pm 10\text{ V}$, $R_L = 2\text{ k}\Omega$, $C_L = 100\text{ pF}$, unity gain	0.25	0.5		V/ μ s
t_r	Rise time $V_i = \pm 20\text{ mV}$, $R_L = 2\text{ k}\Omega$, $C_L = 100\text{ pF}$, unity gain		0.3		μ s
K_{ov}	Overshoot $V_i = 20\text{ mV}$, $R_L = 2\text{ k}\Omega$, $C_L = 100\text{ pF}$, unity gain		5		%
R_i	Input resistance	0.3	2		M Ω

**Table 3. Electrical characteristics at $V_{CC} = \pm 15\text{ V}$, $T_{amb} = 25\text{ °C}$
(unless otherwise specified) (continued)**

Symbol	Parameter	Min.	Typ.	Max.	Unit
GBP	Gain bandwidth product $V_i = 10\text{ mV}$, $R_L = 2\text{ k}\Omega$, $C_L = 100\text{ pF}$, $f = 100\text{ kHz}$	0.7	1		MHz
THD	Total harmonic distortion $f = 1\text{ kHz}$, $A_v = 20\text{ dB}$, $R_L = 2\text{ k}\Omega$, $V_o = 2\text{ V}_{pp}$, $C_L = 100\text{ pF}$, $T_{amb} = +25\text{ °C}$		0.06		%
e_n	Equivalent input noise voltage $f = 1\text{ kHz}$, $R_s = 100\text{ }\Omega$		23		$\frac{\text{nV}}{\sqrt{\text{Hz}}}$
ϕ_m	Phase margin		50		Degree

4 Package information

In order to meet environmental requirements, ST offers these devices in different grades of ECOPACK[®] packages, depending on their level of environmental compliance. ECOPACK[®] specifications, grade definitions and product status are available at: www.st.com. ECOPACK[®] is an ST trademark.

4.1 DIP8 package information

Figure 2. DIP8 package mechanical drawing

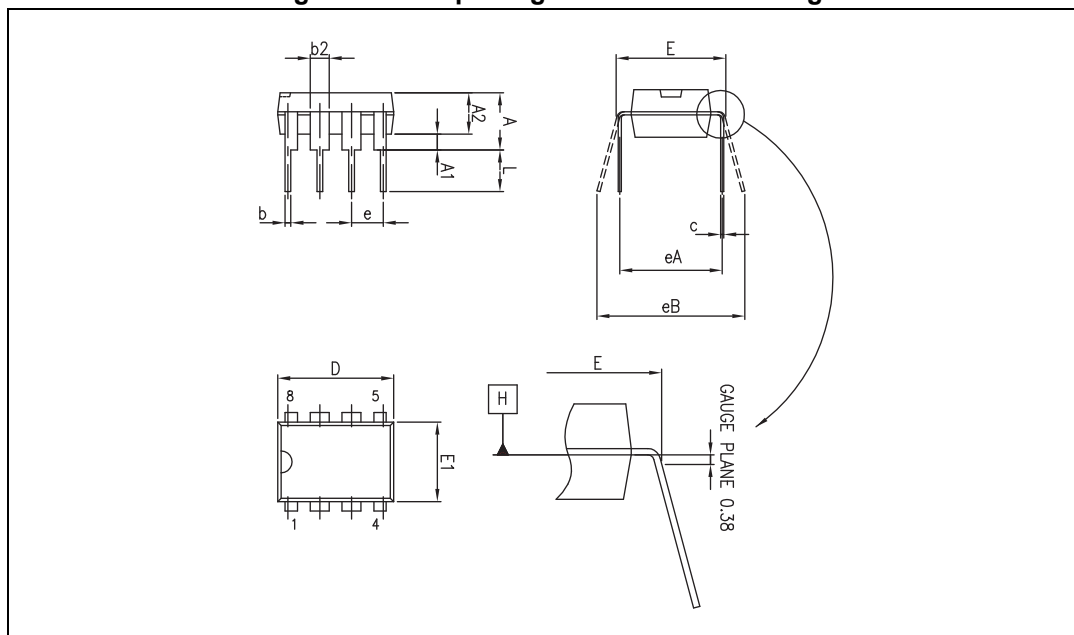

Table 4. DIP8 package mechanical data

Ref.	Dimensions					
	Millimeters			Inches		
	Min.	Typ.	Max.	Min.	Typ.	Max.
A			5.33			0.210
A1	0.38			0.015		
A2	2.92	3.30	4.95	0.115	0.130	0.195
b	0.36	0.46	0.56	0.014	0.018	0.022
b2	1.14	1.52	1.78	0.045	0.060	0.070
c	0.20	0.25	0.36	0.008	0.010	0.014
D	9.02	9.27	10.16	0.355	0.365	0.400
E	7.62	7.87	8.26	0.300	0.310	0.325
E1	6.10	6.35	7.11	0.240	0.250	0.280
e		2.54			0.100	
eA		7.62			0.300	
eB			10.92			0.430
L	2.92	3.30	3.81	0.115	0.130	0.150

4.2 SO8 package information

Figure 3. SO8 package mechanical drawing

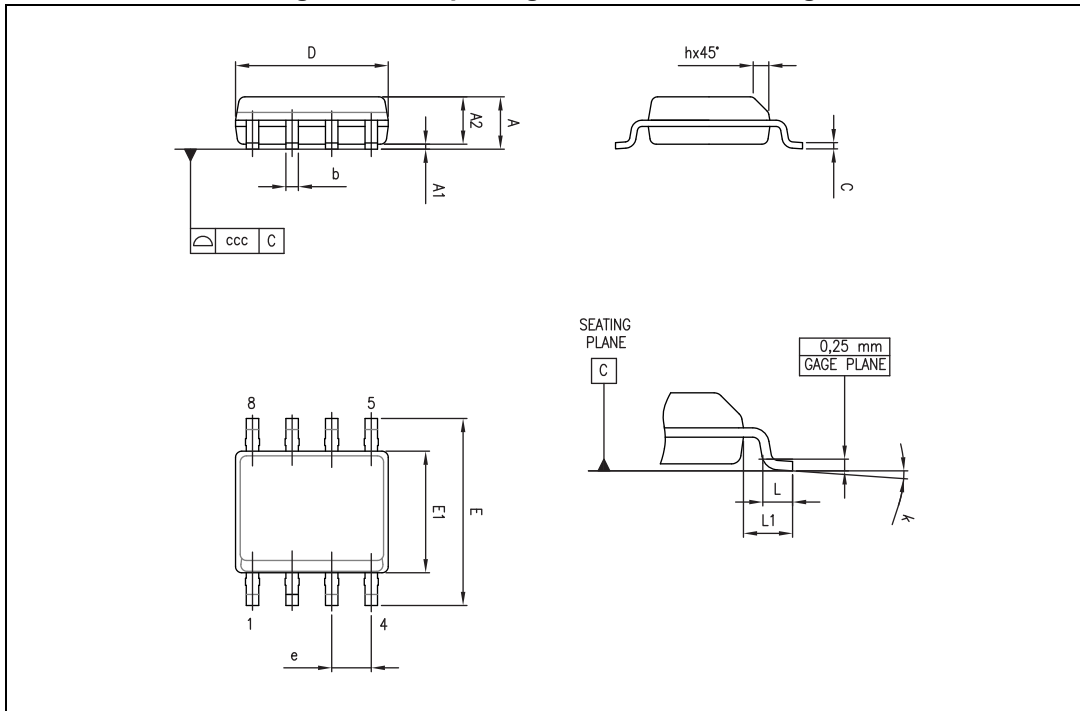

Table 5. SO8 package mechanical data

Ref.	Dimensions					
	Millimeters			Inches		
	Min.	Typ.	Max.	Min.	Typ.	Max.
A			1.75			0.069
A1	0.10		0.25	0.004		0.010
A2	1.25			0.049		
b	0.28		0.48	0.011		0.019
c	0.17		0.23	0.007		0.010
D	4.80	4.90	5.00	0.189	0.193	0.197
E	5.80	6.00	6.20	0.228	0.236	0.244
E1	3.80	3.90	4.00	0.150	0.154	0.157
e		1.27			0.050	
h	0.25		0.50	0.010		0.020
L	0.40		1.27	0.016		0.050
L1		1.04			0.040	
k	0		8 °	1 °		8 °
ccc			0.10			0.004

5 Ordering information

Table 6. Order codes

Order code	Temperature range	Package	Packing	Marking
UA741CN	0° C, +70° C	DIP8	Tube	UA741CN
UA741CD/CDT		SO-8	Tube or tape & reel	741C
UA741IN	-40° C, +105° C	DIP8	Tube	UA741IN
UA741ID/IDT		SO-8	Tube or tape & reel	741I

6 Revision history

Table 7. Document revision history

Date	Revision	Changes
01-Nov-2001	1	Initial release.
25-May-2009	2	Document reformatted. Added ESD values and thermal resistances in Table 1: Absolute maximum ratings . Added Table 2: Operating conditions . Removed UA741M information and order code in Table 6 .
02-Sep-2013	3	Table 6: Order codes : updated marking for order codes UA741CD/CDT and UA741ID/IDT.

Please Read Carefully:

Information in this document is provided solely in connection with ST products. STMicroelectronics NV and its subsidiaries ("ST") reserve the right to make changes, corrections, modifications or improvements, to this document, and the products and services described herein at any time, without notice.

All ST products are sold pursuant to ST's terms and conditions of sale.

Purchasers are solely responsible for the choice, selection and use of the ST products and services described herein, and ST assumes no liability whatsoever relating to the choice, selection or use of the ST products and services described herein.

No license, express or implied, by estoppel or otherwise, to any intellectual property rights is granted under this document. If any part of this document refers to any third party products or services it shall not be deemed a license grant by ST for the use of such third party products or services, or any intellectual property contained therein or considered as a warranty covering the use in any manner whatsoever of such third party products or services or any intellectual property contained therein.

UNLESS OTHERWISE SET FORTH IN ST'S TERMS AND CONDITIONS OF SALE ST DISCLAIMS ANY EXPRESS OR IMPLIED WARRANTY WITH RESPECT TO THE USE AND/OR SALE OF ST PRODUCTS INCLUDING WITHOUT LIMITATION IMPLIED WARRANTIES OF MERCHANTABILITY, FITNESS FOR A PARTICULAR PURPOSE (AND THEIR EQUIVALENTS UNDER THE LAWS OF ANY JURISDICTION), OR INFRINGEMENT OF ANY PATENT, COPYRIGHT OR OTHER INTELLECTUAL PROPERTY RIGHT.

ST PRODUCTS ARE NOT AUTHORIZED FOR USE IN WEAPONS. NOR ARE ST PRODUCTS DESIGNED OR AUTHORIZED FOR USE IN: (A) SAFETY CRITICAL APPLICATIONS SUCH AS LIFE SUPPORTING, ACTIVE IMPLANTED DEVICES OR SYSTEMS WITH PRODUCT FUNCTIONAL SAFETY REQUIREMENTS; (B) AERONAUTIC APPLICATIONS; (C) AUTOMOTIVE APPLICATIONS OR ENVIRONMENTS, AND/OR (D) AEROSPACE APPLICATIONS OR ENVIRONMENTS. WHERE ST PRODUCTS ARE NOT DESIGNED FOR SUCH USE, THE PURCHASER SHALL USE PRODUCTS AT PURCHASER'S SOLE RISK, EVEN IF ST HAS BEEN INFORMED IN WRITING OF SUCH USAGE, UNLESS A PRODUCT IS EXPRESSLY DESIGNATED BY ST AS BEING INTENDED FOR "AUTOMOTIVE, AUTOMOTIVE SAFETY OR MEDICAL" INDUSTRY DOMAINS ACCORDING TO ST PRODUCT DESIGN SPECIFICATIONS. PRODUCTS FORMALLY ESCC, QML OR JAN QUALIFIED ARE DEEMED SUITABLE FOR USE IN AEROSPACE BY THE CORRESPONDING GOVERNMENTAL AGENCY.

Resale of ST products with provisions different from the statements and/or technical features set forth in this document shall immediately void any warranty granted by ST for the ST product or service described herein and shall not create or extend in any manner whatsoever, any liability of ST.

ST and the ST logo are trademarks or registered trademarks of ST in various countries.

Information in this document supersedes and replaces all information previously supplied.

The ST logo is a registered trademark of STMicroelectronics. All other names are the property of their respective owners.

© 2013 STMicroelectronics - All rights reserved

STMicroelectronics group of companies

Australia - Belgium - Brazil - Canada - China - Czech Republic - Finland - France - Germany - Hong Kong - India - Israel - Italy - Japan - Malaysia - Malta - Morocco - Philippines - Singapore - Spain - Sweden - Switzerland - United Kingdom - United States of America

www.st.com



Компания «Океан Электроники» предлагает заключение долгосрочных отношений при поставках импортных электронных компонентов на взаимовыгодных условиях!

Наши преимущества:

- Поставка оригинальных импортных электронных компонентов напрямую с производств Америки, Европы и Азии, а так же с крупнейших складов мира;
- Широкая линейка поставок активных и пассивных импортных электронных компонентов (более 30 млн. наименований);
- Поставка сложных, дефицитных, либо снятых с производства позиций;
- Оперативные сроки поставки под заказ (от 5 рабочих дней);
- Экспресс доставка в любую точку России;
- Помощь Конструкторского Отдела и консультации квалифицированных инженеров;
- Техническая поддержка проекта, помощь в подборе аналогов, поставка прототипов;
- Поставка электронных компонентов под контролем ВП;
- Система менеджмента качества сертифицирована по Международному стандарту ISO 9001;
- При необходимости вся продукция военного и аэрокосмического назначения проходит испытания и сертификацию в лаборатории (по согласованию с заказчиком);
- Поставка специализированных компонентов военного и аэрокосмического уровня качества (Xilinx, Altera, Analog Devices, Intersil, Interpoint, Microsemi, Actel, Aeroflex, Peregrine, VPT, Syfer, Eurofarad, Texas Instruments, MS Kennedy, Miteq, Cobham, E2V, MA-COM, Hittite, Mini-Circuits, General Dynamics и др.);

Компания «Океан Электроники» является официальным дистрибьютором и эксклюзивным представителем в России одного из крупнейших производителей разъемов военного и аэрокосмического назначения «**JONHON**», а так же официальным дистрибьютором и эксклюзивным представителем в России производителя высокотехнологичных и надежных решений для передачи СВЧ сигналов «**FORSTAR**».



JONHON

«**JONHON**» (основан в 1970 г.)

Разъемы специального, военного и аэрокосмического назначения:

(Применяются в военной, авиационной, аэрокосмической, морской, железнодорожной, горно- и нефтедобывающей отраслях промышленности)

«**FORSTAR**» (основан в 1998 г.)

ВЧ соединители, коаксиальные кабели, кабельные сборки и микроволновые компоненты:

(Применяются в телекоммуникациях гражданского и специального назначения, в средствах связи, РЛС, а так же военной, авиационной и аэрокосмической отраслях промышленности).



Телефон: 8 (812) 309-75-97 (многоканальный)

Факс: 8 (812) 320-03-32

Электронная почта: ocean@oceanchips.ru

Web: <http://oceanchips.ru/>

Адрес: 198099, г. Санкт-Петербург, ул. Калинина, д. 2, корп. 4, лит. А