

---

## 36V INPUT VOLTAGE DETECTOR

---

NO.EA-187-160229

### OUTLINE

R3119x Series are CMOS-based 36V input (absolute maximum ratings: 50V) voltage detector with high detector threshold accuracy and ultra-low supply current. Each of those ICs consists of a voltage reference unit, a comparator, resistors for detector threshold setting, an output driver and a hysteresis circuit.

There are two types: R3119xxxxA has the C<sub>D</sub> pin for setting the output delay time. R3119xxxxE has the SENSE pin.

The supply current of IC is only 3.3μA. The detector threshold is fixed in the IC and can be set with a step of 0.1V in the range of 2.3V to 12V. Detector threshold accuracy is 1.5%. The output type is Nch Open drain type.

The R3119x is offered in a small-size 6-pin DFN(PLP)1820-6 package in addition to a 5-pin SOT-23-5 package.

### FEATURES

- Supply Current ..... Typ. 3.3μA
- Operating Voltage Range..... 1.2V to 36.0V (C<sub>D</sub> pin type: R3119xxxxA)  
2.1V to 6.0V (SENSE pin type: R3119xxxxE)
- Operating Temperature Range ..... -40°C to 105°C
- Detector Threshold Range..... 2.3V to 12.0V (0.1V steps)  
(For other voltages, please refer to MARK INFORMATIONS.)
- Detector Threshold Accuracy ..... ±1.5% (T<sub>opt</sub>=25°C)
- Temperature-Drift Coefficient of Detector Threshold ..... Typ. ±100ppm/°C
- Output Delay Time (Power ON Reset Delay Time)..... Typ. 85ms (C<sub>D</sub>=0.01μF, C<sub>D</sub> pin type)
- Output Delay Time Accuracy..... -50% to 80% (C<sub>D</sub> pin type: R3119xxxxA)
- Output Type..... Nch Open Drain
- Package ..... SOT-23-5, DFN(PLP)1820-6

### APPLICATIONS

- CPU and Logic Circuit Reset
- Battery Checker
- Battery Back-up Circuit
- Power Failure Detector for Digital home appliances

# R3119x

NO.EA-187-160229

## BLOCK DIAGRAMS

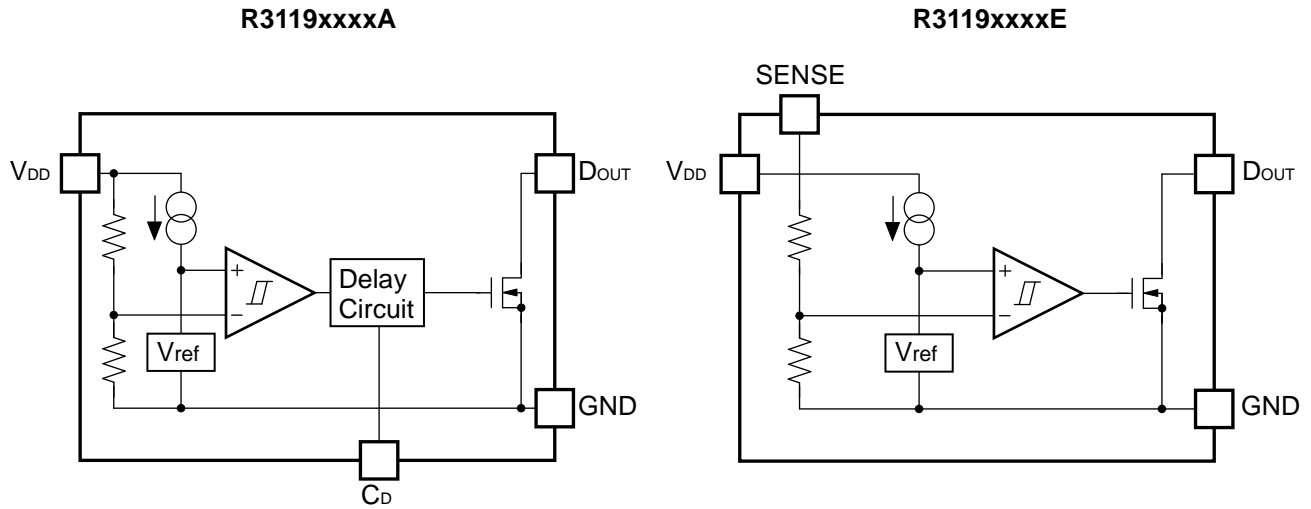

## SELECTION GUIDE

The package type, the detector threshold and the version for the ICs can be selected at the users' request.

Product Name	Package	Quantity per Reel	Pb Free	Halogen Free
R3119Nxxx*-TR-FE	SOT-23-5	3,000 pcs	Yes	Yes
R3119Kxxx*-TR	DFN(PLP)1820-6	5,000 pcs	Yes	Yes

xxx: The detector threshold can be designated in the range from 2.3V(023) to 12.0V(120) in 0.1V steps.  
 (For other voltages, please refer to MARK INFORMATIONS.)

\* : Designation of Version  
 (A) with CD pin type  
 (E) with SENSE pin type

## PIN CONFIGURATIONS

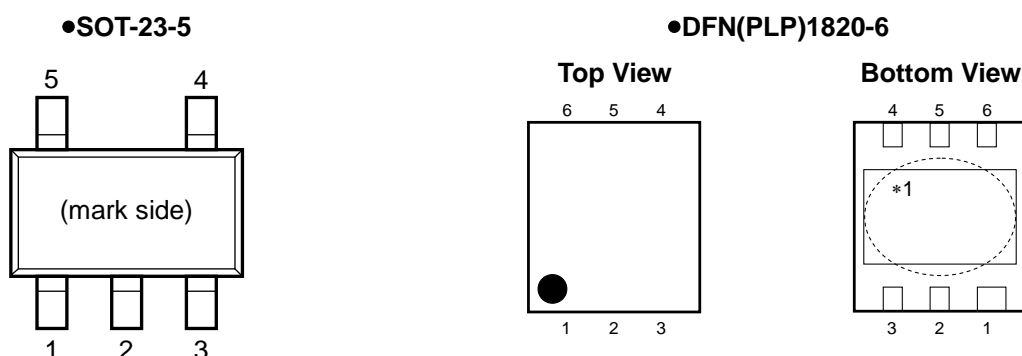

## PIN DESCRIPTIONS

### ● SOT-23-5

Pin No.	Symbol	Description	
1	V <sub>DD</sub>	Input Pin	
2	GND*	Ground Pin	
3	GND*	Ground Pin	
4	D <sub>OUT</sub>	Output Pin ("L" at detection)	
5	C <sub>D</sub>	R3119NxxxA	Connecting pin with external capacitor for setting delay time
	SENSE	R3119NxxxE	Voltage Detector Voltage Sense Pin

\*) No. 2 and No.3 pins must be wired to the GND plane when it is mounted on board.

### ●DFN(PLP)1820-6

Pin No.	Symbol	Description	
1	GND	Ground Pin	
2	NC	No Connection	
3	V <sub>DD</sub>	Input Pin	
4	C <sub>D</sub>	R3119KxxxA	Connecting pin with external capacitor for setting delay time
	SENSE	R3119KxxxE	Voltage Detector Voltage Sense Pin
5	NC	No Connection	
6	D <sub>OUT</sub>	Output Pin ("L" at detection)	

\*) Tab is GND level. (They are connected to the reverse side of this IC.) The tab is better to be connected to the GND, but leaving it open is also acceptable.

---

**R3119x**

---

NO.EA-187-160229

**ABSOLUTE MAXIMUM RATINGS**

Symbol	Item	Rating	Unit	
V <sub>DD</sub>	Supply Voltage	R3119xxxxA	-0.3 to 50.0	V
		R3119xxxxE	-0.3 to 7.0	
V <sub>OUT</sub>	Output Voltage (D <sub>OUT</sub> Pin)	-0.3 to 7.0	V	
V <sub>CD</sub>	Output Voltage (C <sub>D</sub> Pin)	R3119xxxxA	-0.3 to 7.0	V
V <sub>SENSE</sub>	Input Voltage (SENSE Pin)	R3119xxxxE	-0.3 to 50.0	
I <sub>OUT</sub>	Output Current (D <sub>OUT</sub> Pin)	20	mA	
P <sub>D</sub>	Power Dissipation (SOT-23-5)*	420	mW	
	Power Dissipation (DFN(PLP)1820-6)*	880		
T <sub>opt</sub>	Operating Temperature Range	-40 to 105	°C	
T <sub>stg</sub>	Storage Temperature Range	-55 to 125	°C	

\*) For Power Dissipation, please refer to PACKAGE INFORMATION.

**ABSOLUTE MAXIMUM RATINGS**

Electronic and mechanical stress momentarily exceeded absolute maximum ratings may cause the permanent damages and may degrade the life time and safety for both device and system using the device in the field.

The functional operation at or over these absolute maximum ratings is not assured.

## ELECTRICAL CHARACTERISTICS

### • R3119xxxxA (C<sub>D</sub> pin type)

The specification in  is checked and guaranteed by design engineering at  $-40^{\circ}\text{C} \leq T_{\text{opt}} \leq 105^{\circ}\text{C}$ .

T<sub>opt</sub>=25°C

Symbol	Item	Conditions	Min.	Typ.	Max.	Unit	
-V <sub>DET</sub>	Detector Threshold	V <sub>DD</sub> pin	T <sub>opt</sub> =25°C	×0.985		×1.015	V
			-40°C ≤ T <sub>opt</sub> ≤ 105°C	×0.970		×1.020	
V <sub>HYS</sub>	Detector Threshold Hysteresis		3.5	5	6.5	%	
I <sub>SS</sub>	Supply Current	V <sub>DD</sub> = -V <sub>DET</sub> -0.1V		3.3	5.6	μA	
		V <sub>DD</sub> = -V <sub>DET</sub> +1.0V		3.3	5.5		
V <sub>DDH</sub>	Maximum Operating Voltage				36	V	
V <sub>DDL</sub>	Minimum Operating Voltage*	T <sub>opt</sub> =25°C			1.2	V	
		-40°C ≤ T <sub>opt</sub> ≤ 105°C			1.25		
I <sub>OUT</sub>	Output Current (Driver Output Pin)	V <sub>DD</sub> =1.5V, V <sub>DS</sub> =0.05V	230			μA	
		2.3V ≤ -V <sub>DET</sub> < 2.6V	V <sub>DD</sub> =2.2V V <sub>DS</sub> =0.5V	2.8		mA	
		2.6V ≤ -V <sub>DET</sub> < 3.0V	V <sub>DD</sub> =2.5V V <sub>DS</sub> =0.5V	3.3			
		3.0V ≤ -V <sub>DET</sub>	V <sub>DD</sub> =2.9V V <sub>DS</sub> =0.5V	3.5			
I <sub>LEAK</sub>	Nch Driver Leakage Current	V <sub>DD</sub> =36V, V <sub>DS</sub> =6.0V			0.2	μA	
Δ-V <sub>DET</sub> / ΔT <sub>opt</sub>	Detector Threshold Temperature Coefficient	-40°C ≤ T <sub>opt</sub> ≤ 105°C		±100		ppm /°C	
t <sub>delay</sub>	Detector Output Delay Time	V <sub>DD</sub> =1.5V → -V <sub>DET</sub> +2.0V C <sub>D</sub> =0.01μF	45	85	150	ms	

All of unit are tested and specified under load conditions such that T<sub>j</sub>≈T<sub>opt</sub>=25°C except for Detector Threshold Temperature Coefficient.

\*) This value is the minimum input voltage when the output voltage is 0.1V or less at detection.  
(The pull-up resistance; 100kΩ, the pull-up voltage; 5.0V)

### RECOMMENDED OPERATING CONDITIONS (ELECTRICAL CHARACTERISTICS)

All of electronic equipment should be designed that the mounted semiconductor devices operate within the recommended operating conditions. The semiconductor devices cannot operate normally over the recommended operating conditions, even if when they are used over such conditions by momentary electronic noise or surge. And the semiconductor devices may receive serious damage when they continue to operate over the recommended operating conditions.

## R3119x

NO.EA-187-160229

### • R3119xxxxE (SENSE pin type)

The specification in  is checked and guaranteed by design engineering at  $-40^{\circ}\text{C} \leq T_{\text{opt}} \leq 105^{\circ}\text{C}$ .

$T_{\text{opt}}=25^{\circ}\text{C}$

Symbol	Item	Conditions		Min.	Typ.	Max.	Unit
$V_{\text{DD}}$	Operating Voltage			2.1*		6	V
$-V_{\text{DET}}$	Detector Threshold	SENSE pin $V_{\text{DD}}=6\text{V}$	$T_{\text{opt}}=25^{\circ}\text{C}$	$\times 0.985$		$\times 1.015$	V
			$-40^{\circ}\text{C} \leq T_{\text{opt}} \leq 105^{\circ}\text{C}$	$\times 0.970$		$\times 1.020$	
$V_{\text{HYS}}$	Detector Threshold Hysteresis	$V_{\text{DD}}=6\text{V}$		3.5	5	6.5	%
$I_{\text{SS}}$	Supply Current	$V_{\text{DD}}=6\text{V}, V_{\text{SENSE}}=-V_{\text{DET}}-0.1\text{V}$			3.3	5.5	$\mu\text{A}$
		$V_{\text{DD}}=6\text{V}, V_{\text{SENSE}}=-V_{\text{DET}}+1.0\text{V}$			3.3	5.5	
$R_{\text{SENSE}}$	Sense Resistor			4.5		120	$\text{M}\Omega$
$I_{\text{OUT}}$	Output Current (Driver Output Pin)	$V_{\text{SENSE}} < -V_{\text{DET}}$	$V_{\text{DD}}=2.1\text{V}$ $V_{\text{DS}}=0.05\text{V}$	420			$\mu\text{A}$
		$V_{\text{SENSE}} < -V_{\text{DET}}$	$V_{\text{DD}}=2.2\text{V}$ $V_{\text{DS}}=0.5\text{V}$	2.8			$\text{mA}$
$I_{\text{LEAK}}$	Nch Driver Leakage Current	$V_{\text{DD}}=6\text{V}, V_{\text{SENSE}}=36\text{V}, V_{\text{DS}}=6.0\text{V}$				0.2	$\mu\text{A}$
$\Delta-V_{\text{DET}}/\Delta T_{\text{opt}}$	Detector Threshold Temperature Coefficient	$-40^{\circ}\text{C} \leq T_{\text{opt}} \leq 105^{\circ}\text{C}$			$\pm 100$		$\text{ppm}/^{\circ}\text{C}$
$t_{\text{PLH}}$	Output Delay Time	$V_{\text{DD}}=6\text{V}$ $V_{\text{SENSE}}=1.5\text{V} \rightarrow -V_{\text{DET}}+2.0\text{V}$			15		$\mu\text{s}$
$V_{\text{SENSE}}$	Input Voltage (SENSE Pin)			0		36	V

All of unit are tested and specified under load conditions such that  $T_j \approx T_{\text{opt}}=25^{\circ}\text{C}$  except for Detector Threshold Temperature Coefficient and Output Delay Time.

\*) Minimum operating voltage of "SENSE pin type" is minimum supply voltage to obtain correct detection voltage.

### RECOMMENDED OPERATING CONDITIONS (ELECTRICAL CHARACTERISTICS)

All of electronic equipment should be designed that the mounted semiconductor devices operate within the recommended operating conditions. The semiconductor devices cannot operate normally over the recommended operating conditions, even if when they are used over such conditions by momentary electronic noise or surge. And the semiconductor devices may receive serious damage when they continue to operate over the recommended operating conditions.

## TIMING CHART

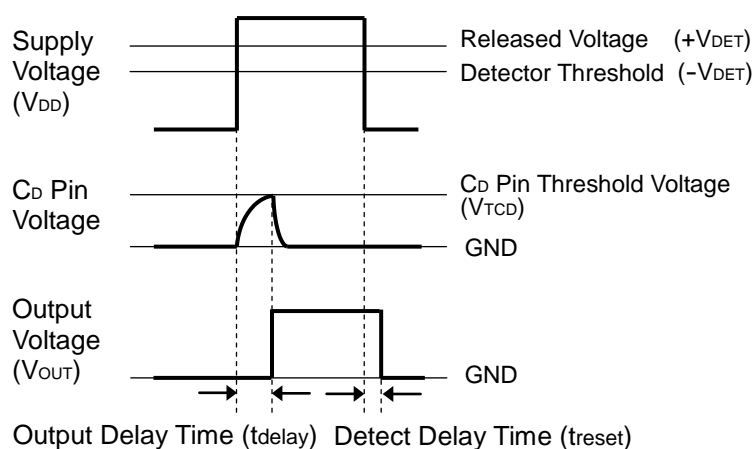

When the supply voltage, which is higher than released voltage, is forced to  $V_{DD}$  pin, charge to an external capacitor starts, then  $C_D$  pin voltage increases. Until the  $C_D$  pin voltage reaches to  $C_D$  pin threshold voltage, output voltage maintains "L". When the  $C_D$  pin voltage becomes higher than  $C_D$  pin threshold voltage, output voltage is reversed from "L" to "H". Where the time interval between the rising edge of supply voltage and output voltage reverse point means output delay time.

When the output voltage reverses from "L" to "H", the external capacitor starts to discharge. Therefore, when lower voltage than the detector threshold voltage is forced to  $V_{DD}$  pin, the output voltage reverses from "H" to "L" thus the detect delay time is constant not being affected by the external capacitor.

### • Output Delay Time

Output Delay Time ( $t_{delay}$ ) can be calculated with the next formula using the external capacitor:

$$t_{delay} (s) = 8.5 \times 10^6 \times C_D (F)$$

## DEFINITION OF OUTPUT DELAY TIME

Output Delay Time ( $t_{delay}$ ) is defined as follows:

Under the condition of the output pin ( $D_{OUT}$ ) is pulled up through a resistor of  $100k\Omega$  to 5V, the time interval between the rising edge of  $V_{DD}$  pulse from 1.5V to  $(-V_{DET})+2.0V$  pulse voltage is supplied, the becoming of the output voltage to 2.5V.

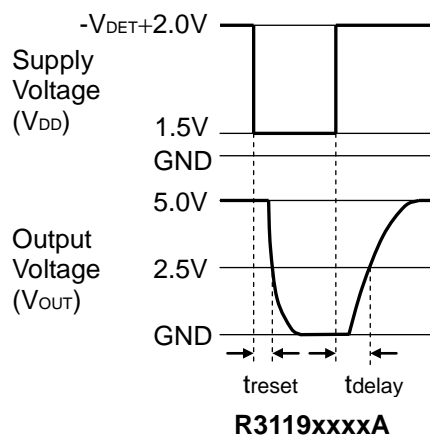

R3119xxxxA

## OPERATION

### • Operation of R3119xxxxA (C<sub>D</sub> pin type)

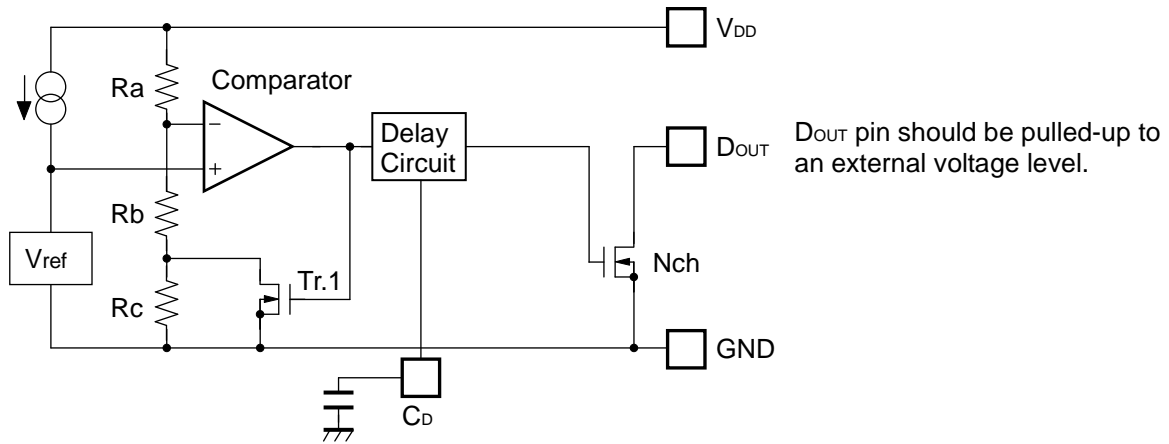

Block Diagram of External Capacitor Connection

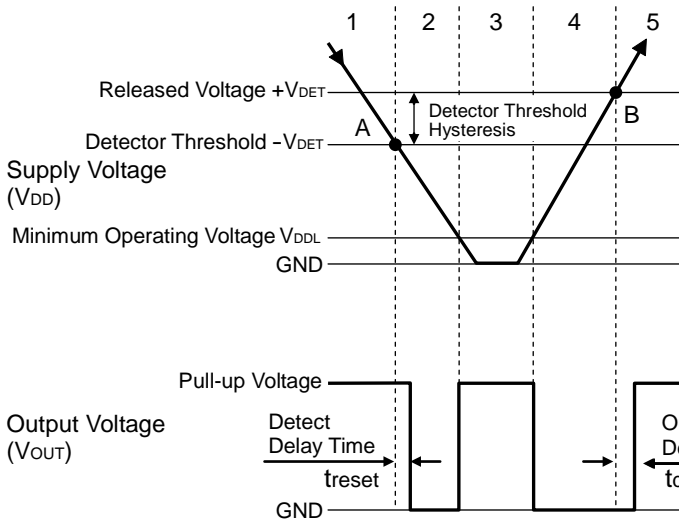

Step	1	2	3	4	5
Comparator (-) Pin Input Voltage	I	II	II	II	I
Comparator Output	L	H	Indefinite	H	L
Tr.1	OFF	ON	Indefinite	ON	OFF
Output Tr. (Nch)	OFF	ON	Indefinite	ON	OFF

$$I \quad \frac{R_b+R_c}{R_a+R_b+R_c} \times V_{DD}$$

$$II \quad \frac{R_b}{R_a+R_b} \times V_{DD}$$

Operation Diagram

### • Explanation of operation

Step 1. The output voltage is equal to the pull-up voltage.

Step 2. At Point "A",  $V_{ref} \geq V_{DD} \times (R_b+R_c)/(R_a+R_b+R_c)$  is true, as a result, the output of comparator is reversed from "L" to "H", therefore the output voltage becomes the GND level. The voltage level of Point A means a detector threshold voltage ( $-V_{DET}$ ).

Step 3. When the supply voltage is lower than the minimum operating voltage, the operation of the output transistor becomes indefinite. The output voltage is equal to the pull-up voltage.

Step 4. The output voltage is equal to the GND level.

Step 5. At Point "B",  $V_{ref} \leq V_{DD} \times R_b/(R_a+R_b)$  is true, as a result, the output of comparator is reversed from "H" to "L", then the output voltage is equal to the pull-up voltage. The voltage level of Point B means a released voltage ( $+V_{DET}$ ).

\*) The difference between a released voltage and a detector threshold voltage is a detector threshold hysteresis.



### • Operation of R3119xxxxE (SENSE pin type)

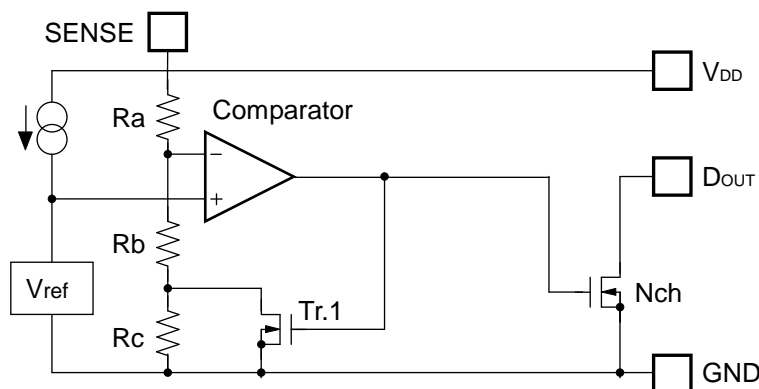

Block Diagram

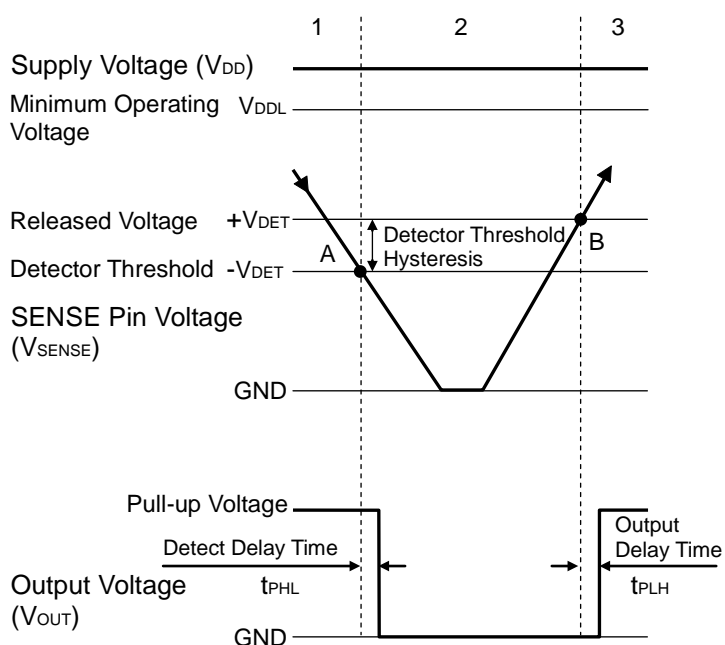

Operation Diagram

Step	1	2	3
Comparator (-) Pin Input Voltage	I	II	I
Comparator Output	L	H	L
Tr.1	OFF	ON	OFF
Output Tr. (Nch)	OFF	ON	OFF

$$I \quad \frac{R_b + R_c}{R_a + R_b + R_c} \times V_{\text{SENSE}}$$

$$II \quad \frac{R_b}{R_a + R_b} \times V_{\text{SENSE}}$$

### • Explanation of operation

Step 1. SENSE pin voltage is larger than detector threshold; the output voltage is equal to the pull-up voltage.

Step 2. At Point "A",  $V_{\text{ref}} \geq V_{\text{SENSE}} \times (R_b + R_c) / (R_a + R_b + R_c)$  is true, as a result, the output of comparator is reversed from "L" to "H", therefore the output voltage becomes the GND level. The voltage level of Point A means a detector threshold voltage ( $-V_{\text{DET}}$ ). (When the supply voltage is higher than the minimum operating voltage, the output voltage is equal to the GND level.)

Step 3. At Point "B",  $V_{\text{ref}} \leq V_{\text{SENSE}} \times R_b / (R_a + R_b)$  is true, as a result, the output of comparator is reversed from "H" to "L", then the output voltage is equal to the pull-up voltage. The voltage level of Point B means a released voltage ( $+V_{\text{DET}}$ ).

\*) The difference between a released voltage and a detector threshold voltage is a detector threshold hysteresis.

## Power supply injection order

The R3119xxxE Series supervise the voltage of the SENSE pin.  $V_{DD}$  pin and SENSE pin can be used at the same voltage level. Likewise,  $V_{DD}$  pin and SENSE pin can be used at the different voltage level. If the  $V_{DD}$  pin and SENSE pin are used at different voltage level, regarding the start-up sequence, force the voltage level to  $V_{DD}$  pin prior to the SENSE pin.

If the SENSE pin voltage is equal or more than the released voltage ( $+V_{DET}$ ),  $D_{OUT}$  pin becomes "H"(Fig.1). Besides, a voltage beyond  $V_{DD}$  pin is also acceptable to SENSE pin.

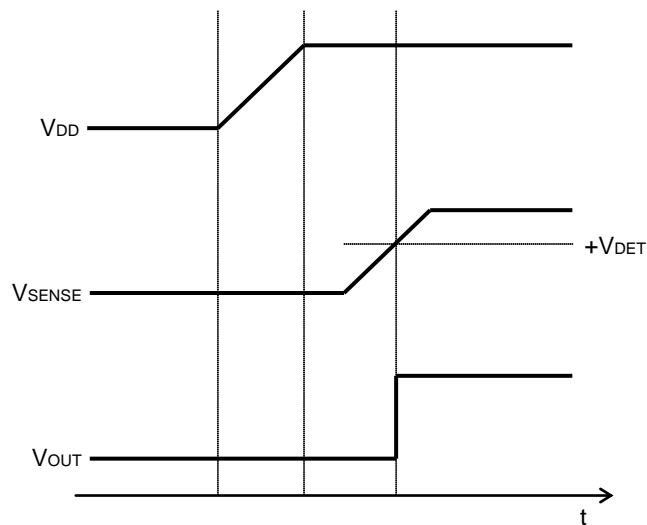
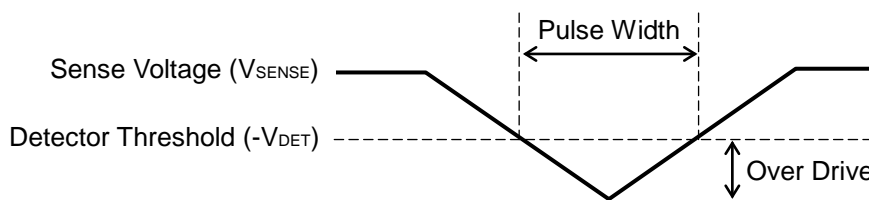
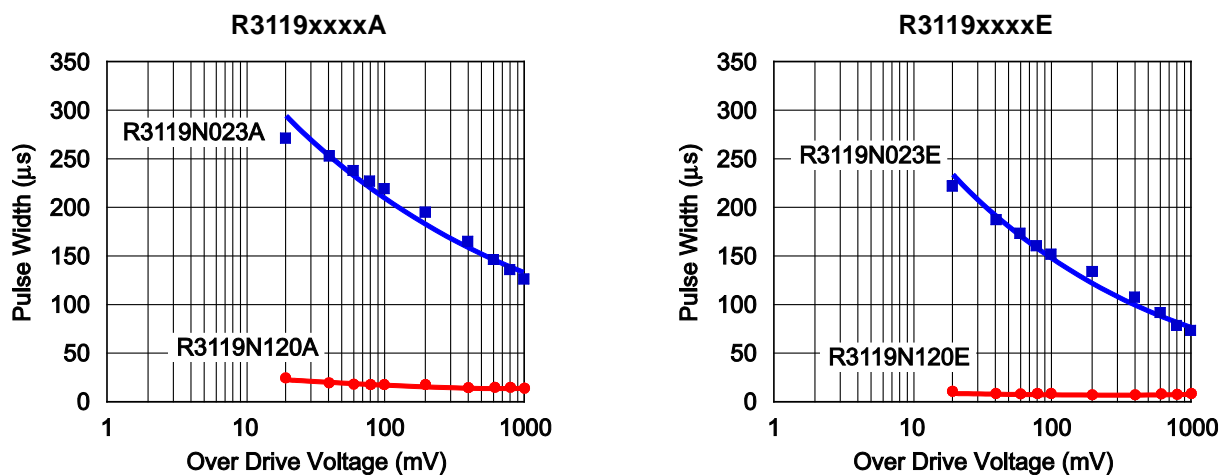

Fig.1 Turn on sequence

## Detector Operation vs. glitch input voltage to the V<sub>DD</sub> pin or SENSE pin

When the R3119x is at released, if the pulse voltage which the detector threshold or lower voltage, the graph below means that the relation between pulse width and the amplitude of the swing to keep the released state for the R3119x.



**$V_{SENSE}$  Input Waveform**

This graph shows the maximum pulse conditions to keep the released voltage. If the pulse with larger amplitude or wider width than the graph above, is input to the V<sub>DD</sub> pin (R3119xxxxA) or to the SENSE pin (R3119xxxxE), the reset signal may be output.

## TYPICAL APPLICATION

- R3119xxxxA (C<sub>D</sub> pin type)

(1) Input Voltage to R3119xxxxA is equal to Input Voltage to CPU

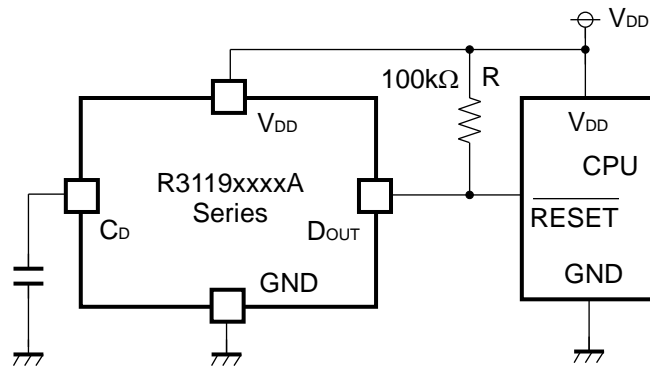

(2) Input Voltage to R3119xxxxA is unequal to Input Voltage to CPU

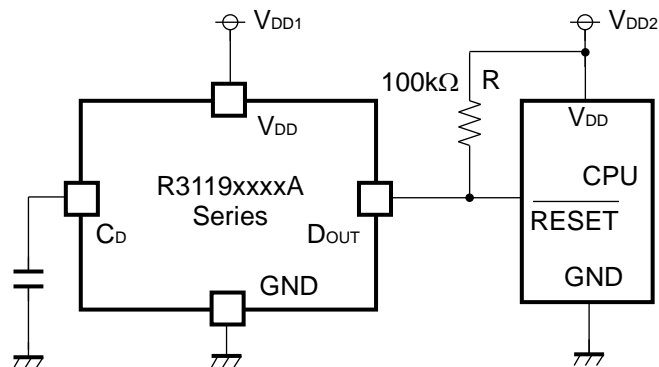

- R3119xxxxE (SENSE pin type)

(1) Input Voltage to R3119xxxxE is equal to Input Voltage to CPU

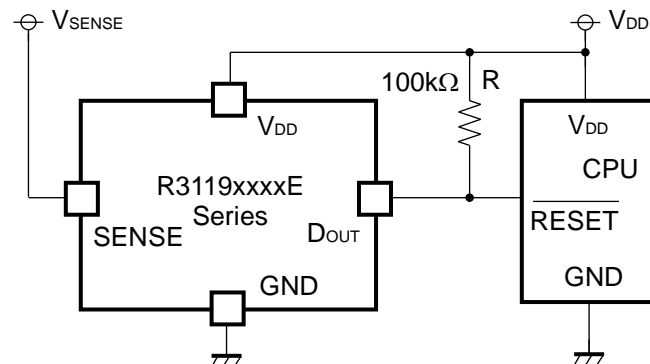

(2) Input Voltage to R3119xxxxE is unequal to Input Voltage to CPU

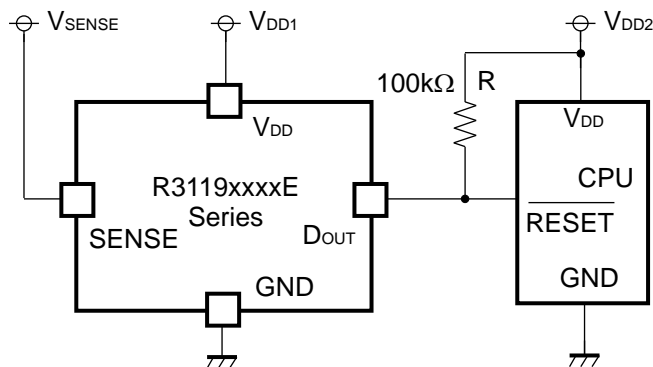

TEST CIRCUITS

- R3119xxxxA (C<sub>D</sub> pin type)

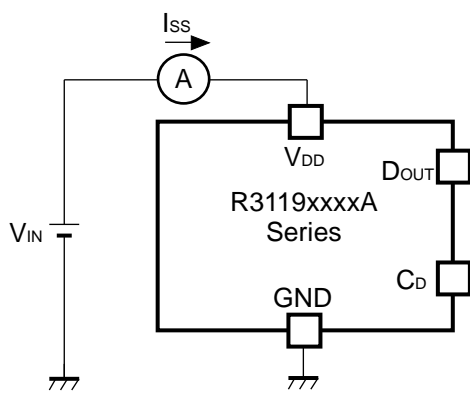

Supply Current Test Circuit

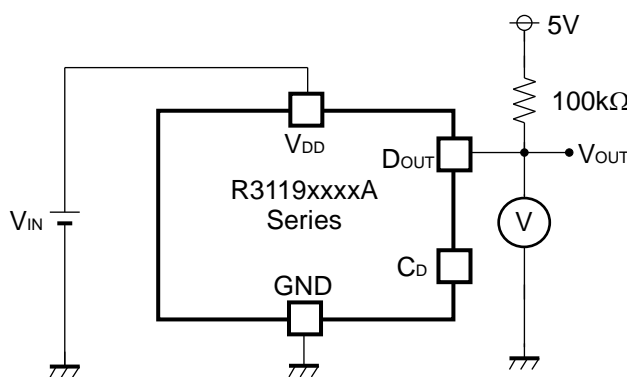

Detector Threshold Test Circuit

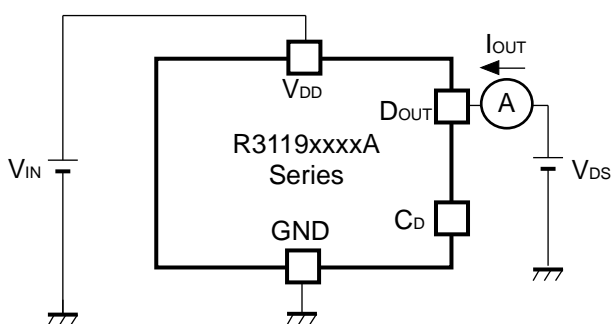

Nch Driver Output Current Test Circuit

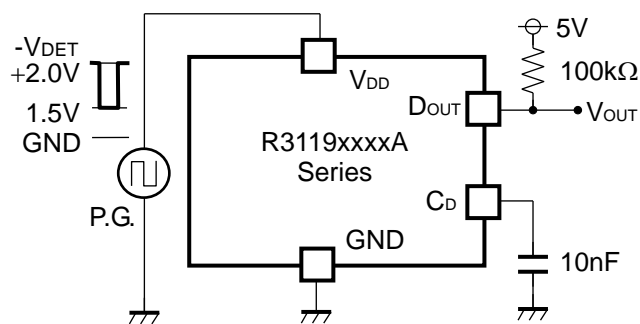

Output Delay Time Test Circuit

---

**R3119x**NO.EA-187-160229

---

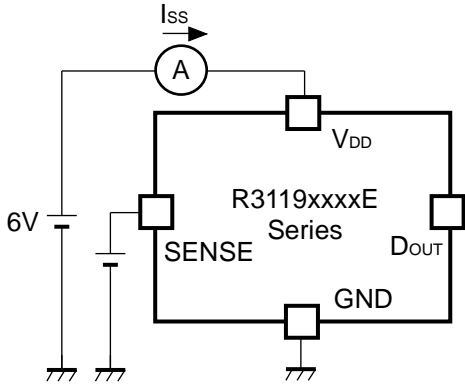
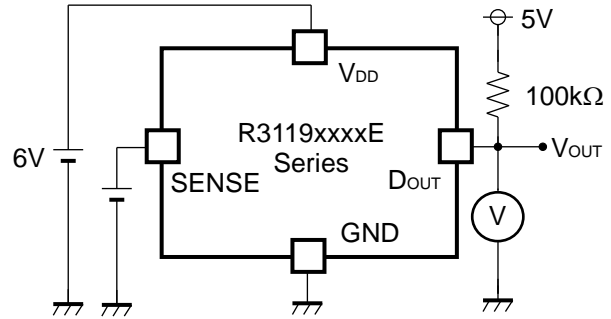
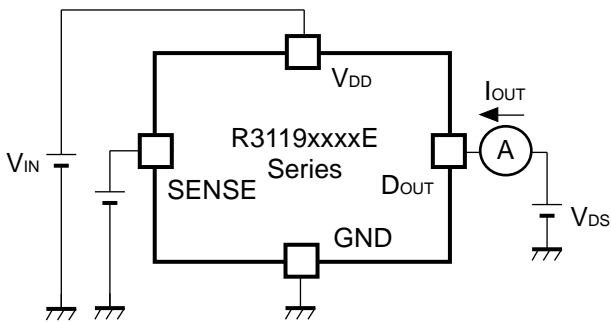
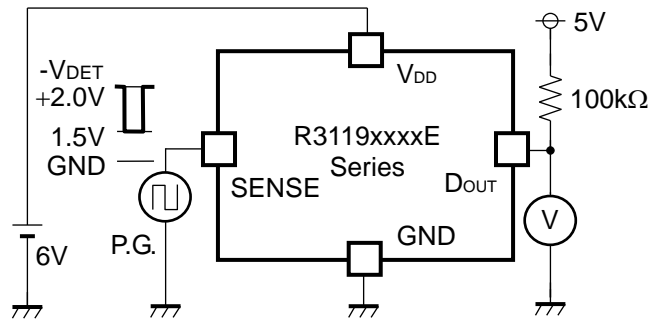
**• R3119xxxxE (SENSE pin type)****Supply Current Test Circuit****Detector Threshold Test Circuit****Nch Driver Output Current Test Circuit****Output Delay Time Test Circuit**

## TYPICAL CHARACTERISTICS

### 1) Supply Current vs. Input Voltage

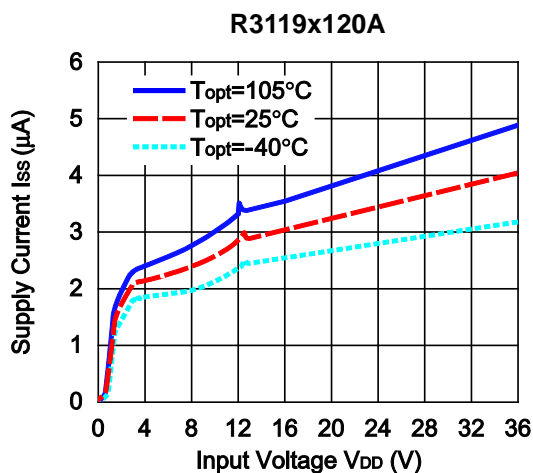
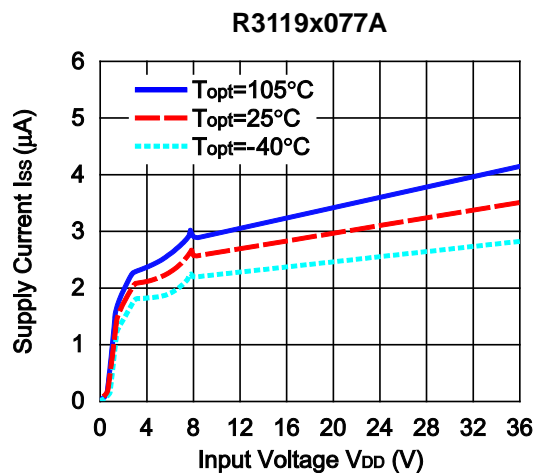
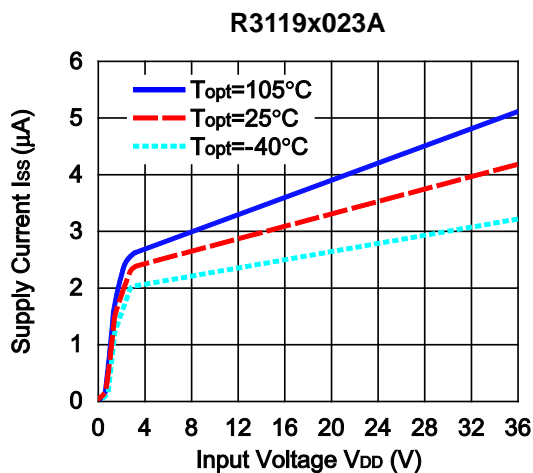

### 2) Detector Threshold vs. Temperature

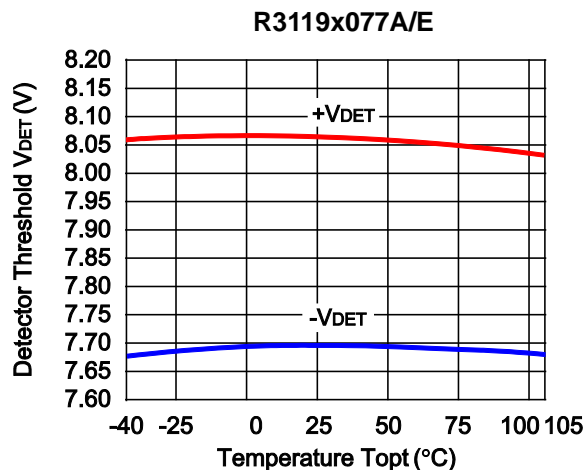
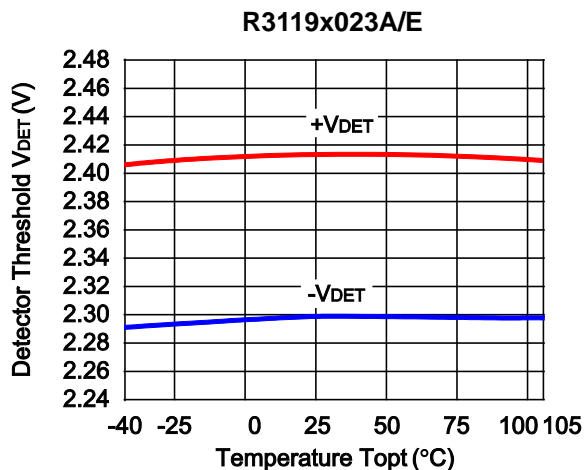

# R3119x

NO.EA-187-160229

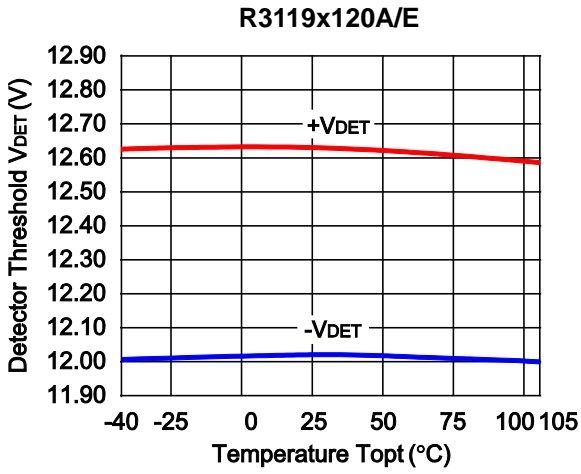

## 3) Output Voltage vs. Input Voltage

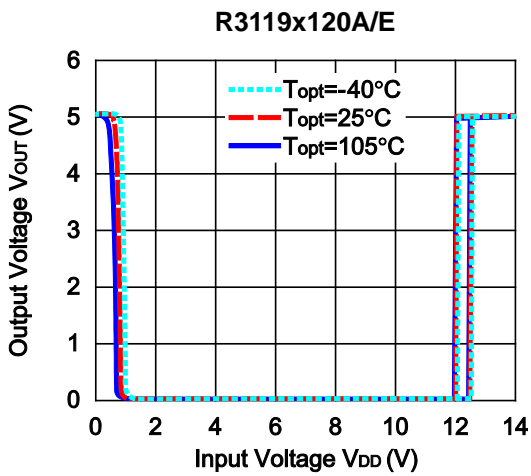
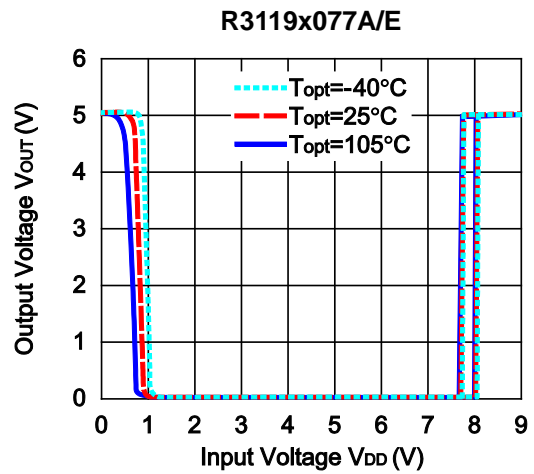
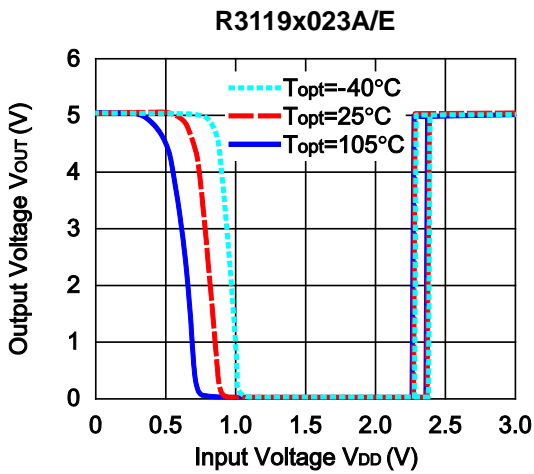



4) Nch Driver Output Current vs. Input Voltage

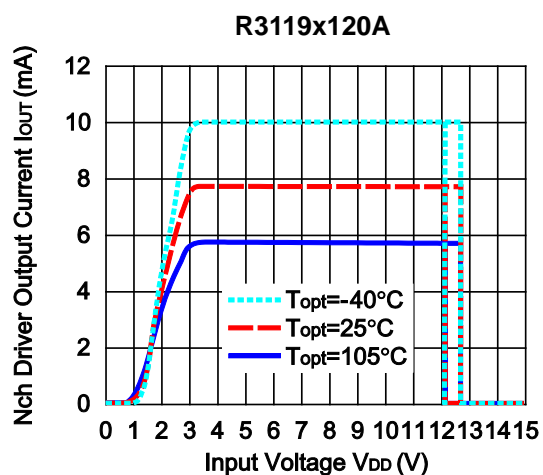
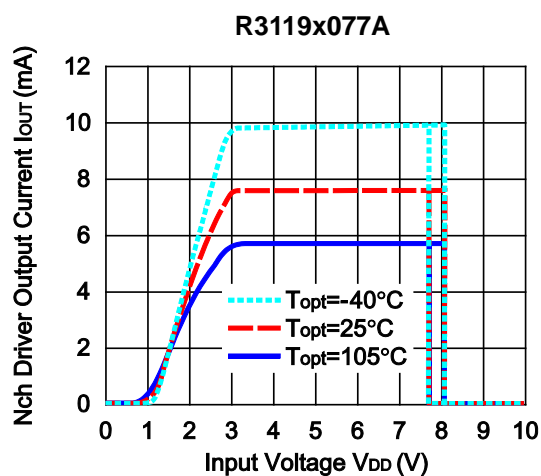
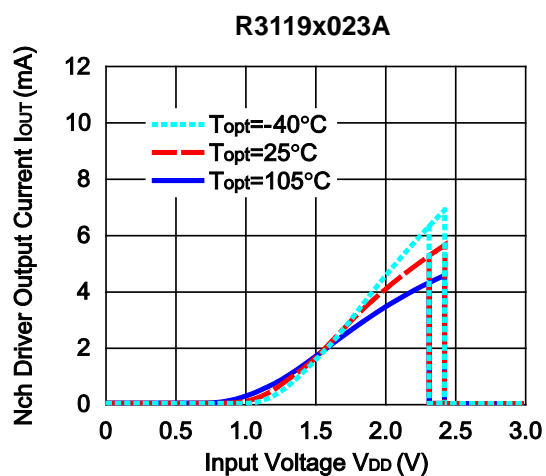

5) Nch Driver Output Current vs.  $V_{DS}$

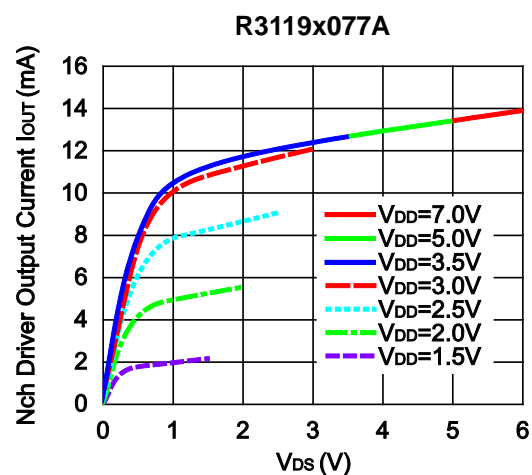
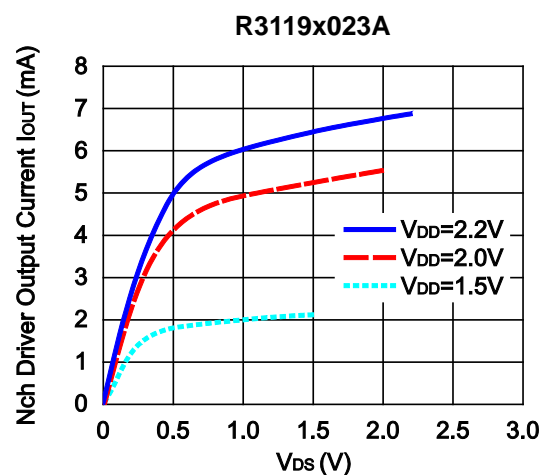

# R3119x

NO.EA-187-160229

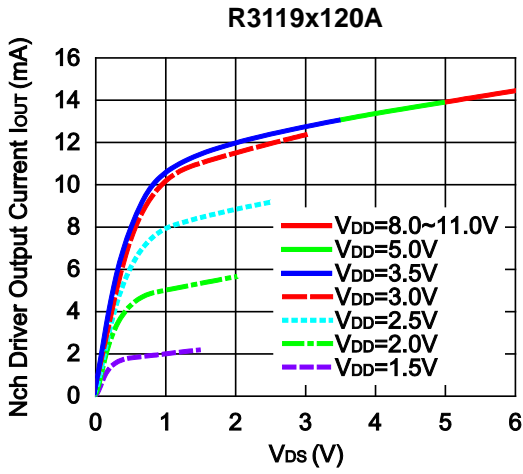

## 6) Output Delay Time vs. External Capacitance ( $T_{opt}=25^{\circ}C$ )

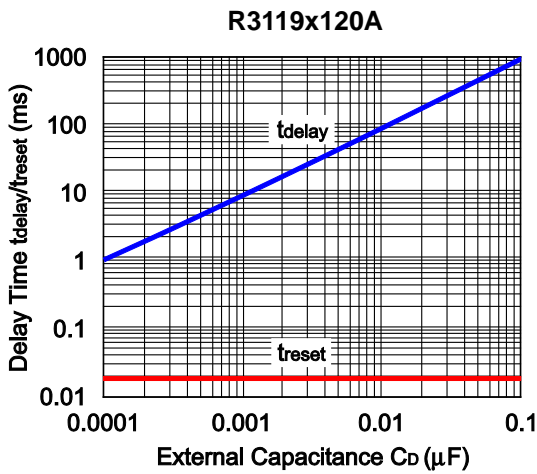
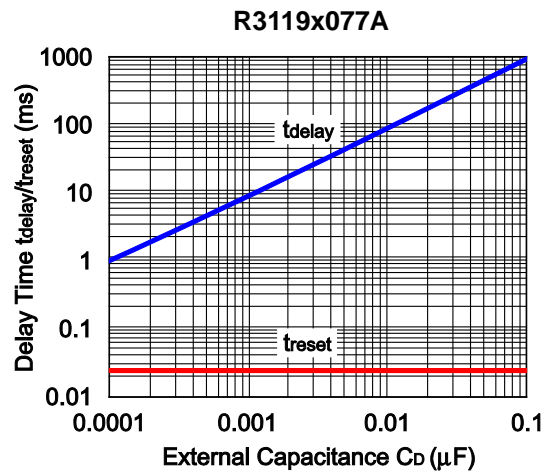
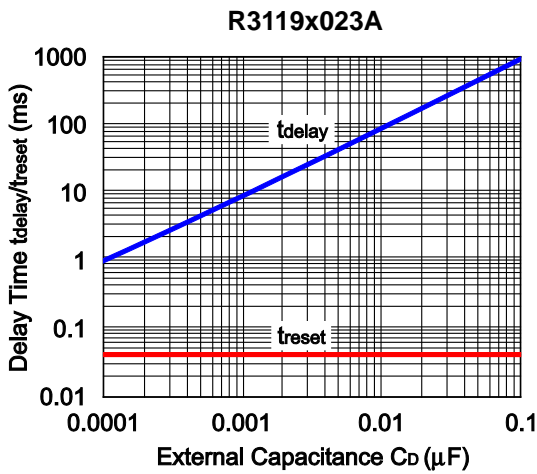

7) Output Delay Time vs. Temperature ( $C_D=0.01\mu F$ )

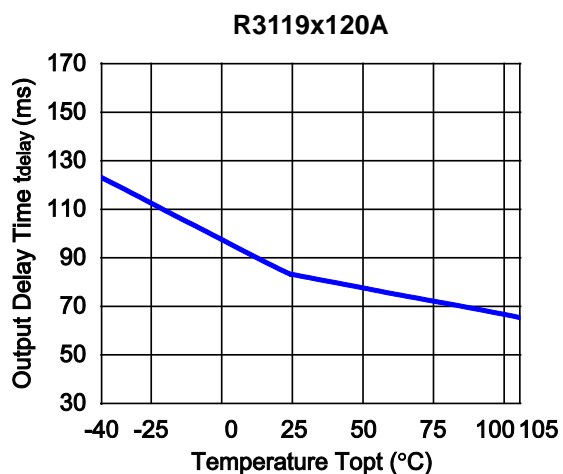
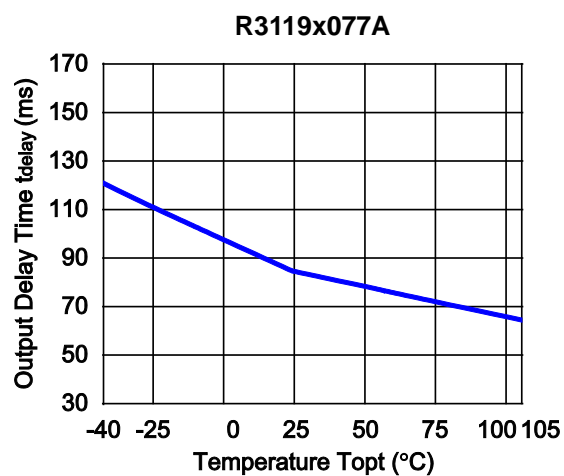
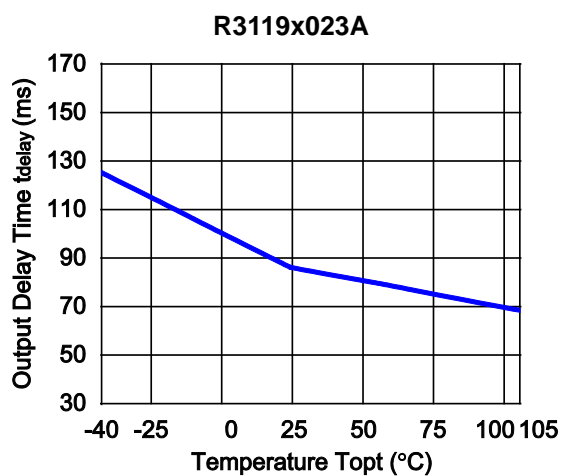

8) Supply Current vs. Input Voltage

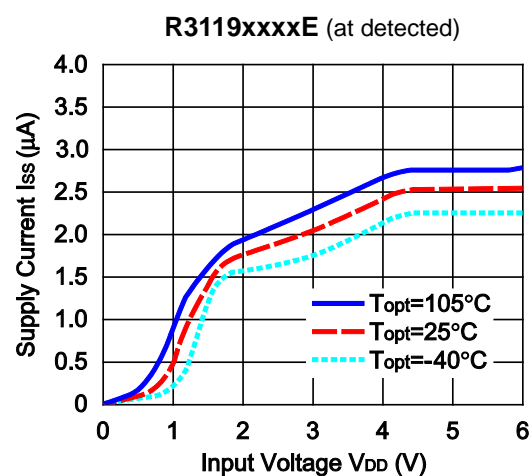
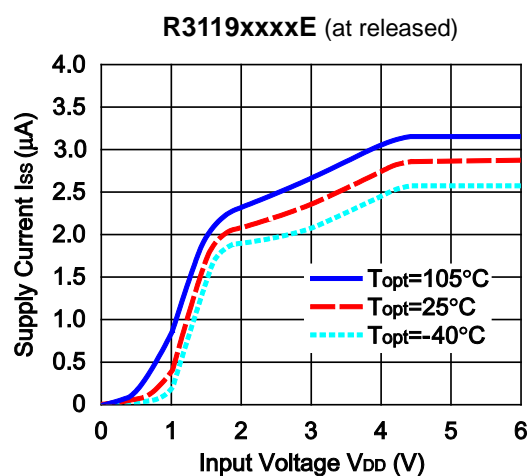

9) Detector Threshold vs. Input Voltage

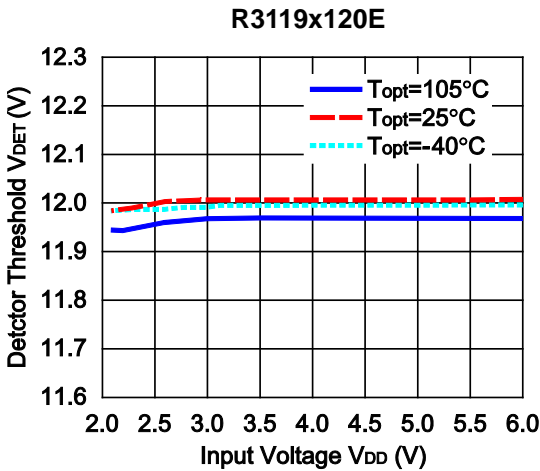
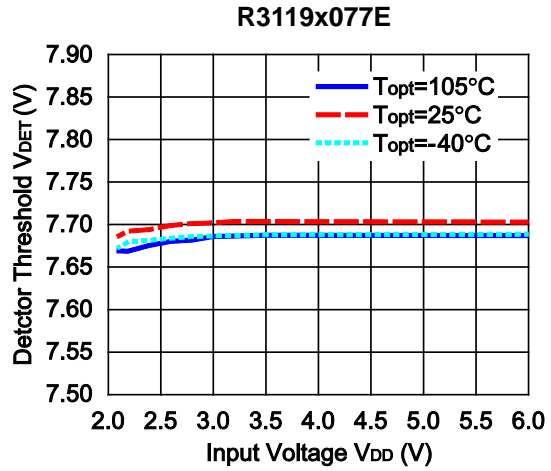
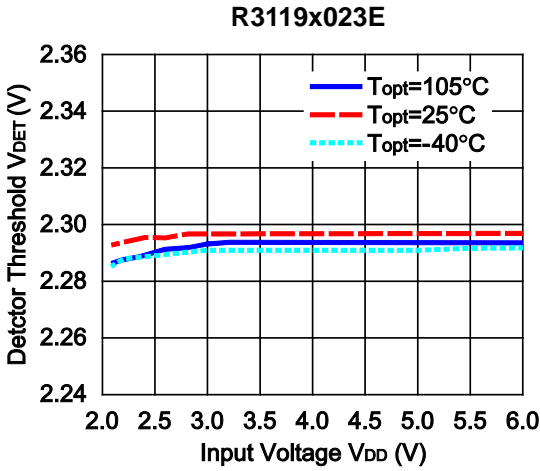

10) Detector Threshold Hysteresis vs. Input Voltage

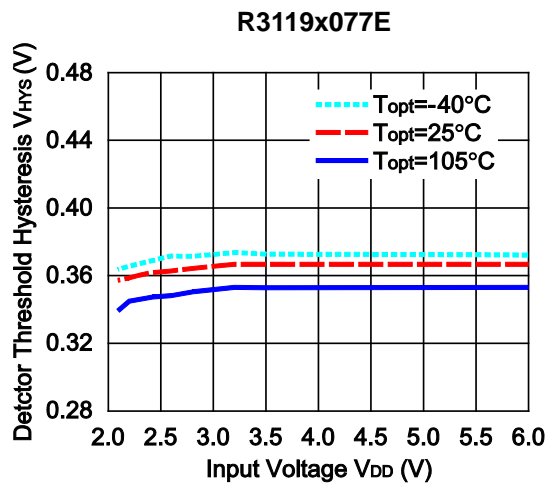
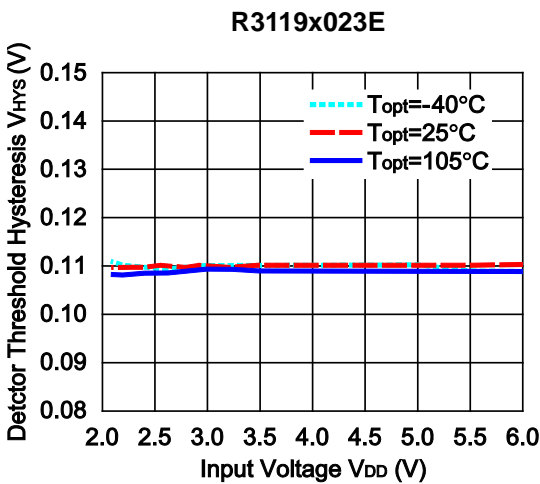

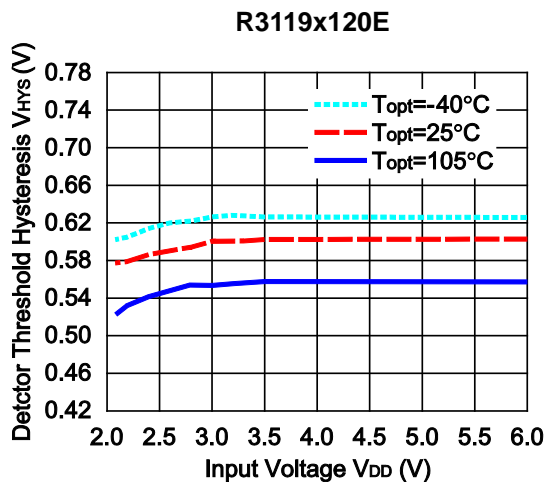

11) Output Voltage vs. SENSE pin Input Voltage ( $T_{opt}=25^{\circ}C$ ) ( $D_{OUT}$  pull up to  $V_{DD}$  with  $100k\Omega$ )

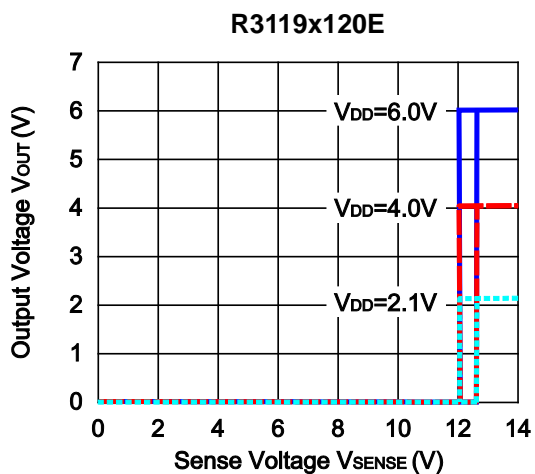
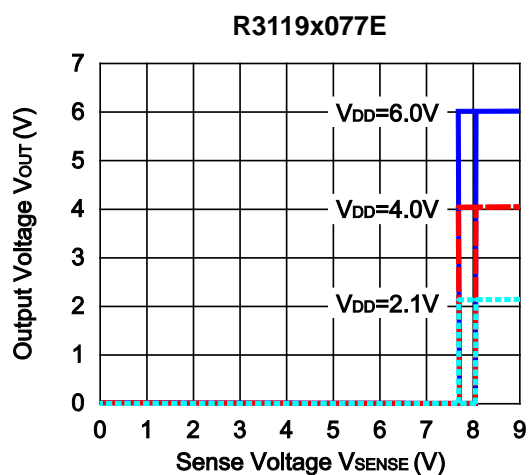
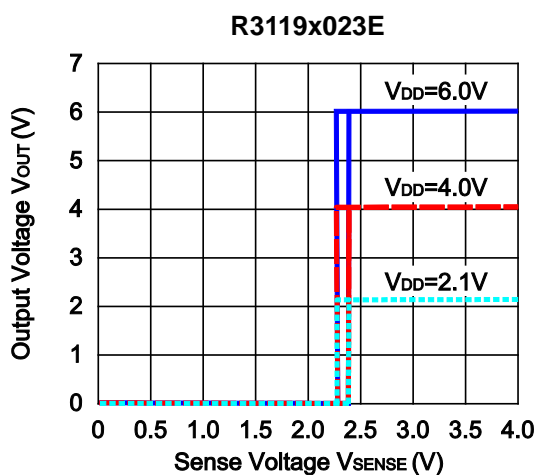

12) Nch Driver Output Current vs. Input Voltage

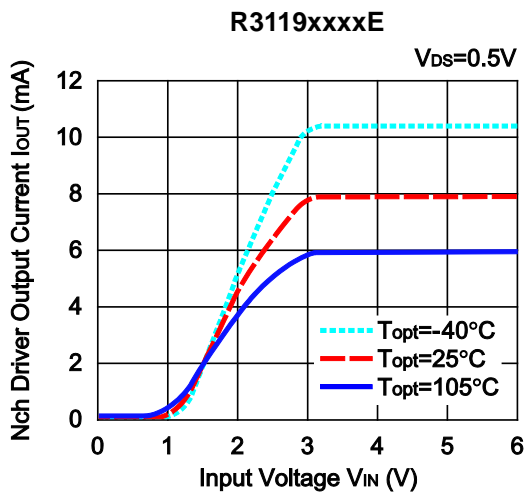

13) Nch Driver Output Current vs.  $V_{DS}$

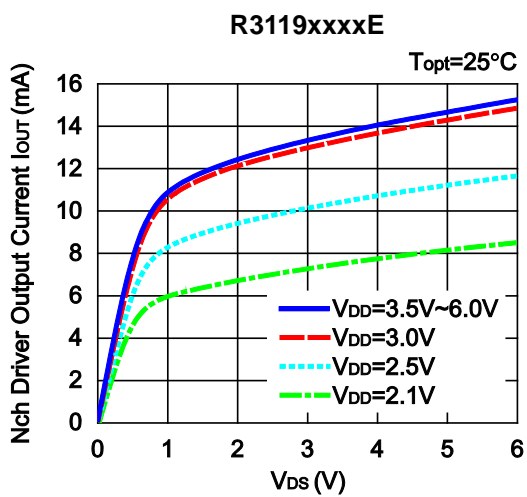

## TECHNICAL NOTES

### When connecting resistors to the device's input pin

When connecting a resistor (R1) to an input of this device, the input voltage decreases by [Device's Consumption Current] x [Resistance Value] only. And, the cross conduction current\*<sup>1</sup>, which occurs when changing from the detecting state to the release state, is decreased the input voltage by [Cross Conduction Current] x [Resistance Value] only. And then, this device will enter the re-detecting state if the input voltage reduction is larger than the difference between the detector voltage and the released voltage.

When the input resistance value is large and the VDD is gone up at mildly in the vicinity of the released voltage, repeating the above operation may result in the occurrence of output.

As shown in Figure A/B, set R1 to become 100 kΩ or less as a guide, and connect C<sub>IN</sub> of 0.1 μF and more to between the input pin and GND. Besides, make evaluations including temperature properties under the actual usage condition, with using the evaluation board like this way. As a result, make sure that the cross conduction current has no problem.

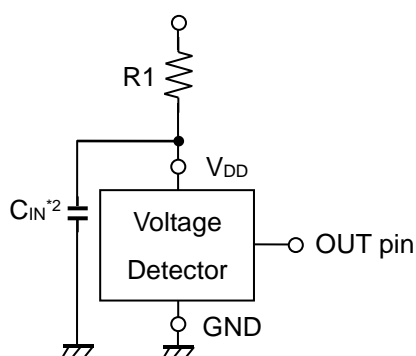

Figure A

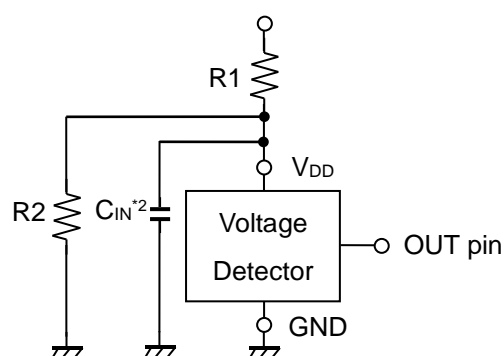

Figure B

\*<sup>1</sup> In the CMOS output type, a charging current for OUT pin is included.

\*<sup>2</sup> Note the bias dependence of capacitors.



1. The products and the product specifications described in this document are subject to change or discontinuation of production without notice for reasons such as improvement. Therefore, before deciding to use the products, please refer to Ricoh sales representatives for the latest information thereon.
2. The materials in this document may not be copied or otherwise reproduced in whole or in part without prior written consent of Ricoh.
3. Please be sure to take any necessary formalities under relevant laws or regulations before exporting or otherwise taking out of your country the products or the technical information described herein.
4. The technical information described in this document shows typical characteristics of and example application circuits for the products. The release of such information is not to be construed as a warranty of or a grant of license under Ricoh's or any third party's intellectual property rights or any other rights.
5. The products listed in this document are intended and designed for use as general electronic components in standard applications (office equipment, telecommunication equipment, measuring instruments, consumer electronic products, amusement equipment etc.). Those customers intending to use a product in an application requiring extreme quality and reliability, for example, in a highly specific application where the failure or misoperation of the product could result in human injury or death (aircraft, spacevehicle, nuclear reactor control system, traffic control system, automotive and transportation equipment, combustion equipment, safety devices, life support system etc.) should first contact us.
6. We are making our continuous effort to improve the quality and reliability of our products, but semiconductor products are likely to fail with certain probability. In order to prevent any injury to persons or damages to property resulting from such failure, customers should be careful enough to incorporate safety measures in their design, such as redundancy feature, fire containment feature and fail-safe feature. We do not assume any liability or responsibility for any loss or damage arising from misuse or inappropriate use of the products.
7. Anti-radiation design is not implemented in the products described in this document.
8. Please contact Ricoh sales representatives should you have any questions or comments concerning the products or the technical information.



**Ricoh is committed to reducing the environmental loading materials in electrical devices with a view to contributing to the protection of human health and the environment.**

Ricoh has been providing RoHS compliant products since April 1, 2006 and Halogen-free products since April 1, 2012.

**RICOH** RICOH ELECTRONIC DEVICES CO., LTD.

<http://www.e-devices.ricoh.co.jp/en/>

#### Sales & Support Offices

##### **RICOH ELECTRONIC DEVICES CO., LTD.**

###### **Higashi-Shinagawa Office (International Sales)**

3-32-3, Higashi-Shinagawa, Shinagawa-ku, Tokyo 140-8655, Japan  
Phone: +81-3-5479-2857 Fax: +81-3-5479-0502

##### **RICOH EUROPE (NETHERLANDS) B.V.**

###### **Semiconductor Support Centre**

Prof. W.H. Keesomlaan 1, 1183 DJ Amstelveen, The Netherlands  
Phone: +31-20-5474-309

##### **RICOH INTERNATIONAL B.V. - German Branch**

###### **Semiconductor Sales and Support Centre**

Oberrather Strasse 6, 40472 Düsseldorf, Germany  
Phone: +49-211-6546-0

##### **RICOH ELECTRONIC DEVICES KOREA CO., LTD.**

3F, Haesung Bldg, 504, Teheran-ro, Gangnam-gu, Seoul, 135-725, Korea  
Phone: +82-2-2135-5700 Fax: +82-2-2051-5713

##### **RICOH ELECTRONIC DEVICES SHANGHAI CO., LTD.**

Room 403, No.2 Building, No.690 Bibo Road, Pu Dong New District, Shanghai 201203,  
People's Republic of China  
Phone: +86-21-5027-3200 Fax: +86-21-5027-3299

##### **RICOH ELECTRONIC DEVICES CO., LTD.**

###### **Taipei office**

Room 109, 10F-1, No.51, Hengyang Rd., Taipei City, Taiwan (R.O.C.)  
Phone: +886-2-2313-1621/1622 Fax: +886-2-2313-1623



# Mouser Electronics

Authorized Distributor

Click to View Pricing, Inventory, Delivery & Lifecycle Information:

## Ricoh Electronics:

[R3119N120A-TR-FE](#) [R3119N025E-TR-FE](#) [R3119N031A-TR-FE](#) [R3119N082A-TR-FE](#) [R3119N045A-TR-FE](#)  
[R3119N030E-TR-FE](#) [R3119N085E-TR-FE](#) [R3119N090A-TR-FE](#) [R3119N030A-TR-FE](#) [R3119N085A-TR-FE](#)  
[R3119N070E-TR-FE](#) [R3119N070A-TR-FE](#) [R3119N042A-TR-FE](#)

Компания «Океан Электроники» предлагает заключение долгосрочных отношений при поставках импортных электронных компонентов на взаимовыгодных условиях!

Наши преимущества:

- Поставка оригинальных импортных электронных компонентов напрямую с производств Америки, Европы и Азии, а так же с крупнейших складов мира;
- Широкая линейка поставок активных и пассивных импортных электронных компонентов (более 30 млн. наименований);
- Поставка сложных, дефицитных, либо снятых с производства позиций;
- Оперативные сроки поставки под заказ (от 5 рабочих дней);
- Экспресс доставка в любую точку России;
- Помощь Конструкторского Отдела и консультации квалифицированных инженеров;
- Техническая поддержка проекта, помощь в подборе аналогов, поставка прототипов;
- Поставка электронных компонентов под контролем ВП;
- Система менеджмента качества сертифицирована по Международному стандарту ISO 9001;
- При необходимости вся продукция военного и аэрокосмического назначения проходит испытания и сертификацию в лаборатории (по согласованию с заказчиком);
- Поставка специализированных компонентов военного и аэрокосмического уровня качества (Xilinx, Altera, Analog Devices, Intersil, Interpoint, Microsemi, Actel, Aeroflex, Peregrine, VPT, Syfer, Eurofarad, Texas Instruments, MS Kennedy, Miteq, Cobham, E2V, MA-COM, Hittite, Mini-Circuits, General Dynamics и др.);

Компания «Океан Электроники» является официальным дистрибьютором и эксклюзивным представителем в России одного из крупнейших производителей разъемов военного и аэрокосмического назначения «JONHON», а так же официальным дистрибьютором и эксклюзивным представителем в России производителя высокотехнологичных и надежных решений для передачи СВЧ сигналов «FORSTAR».



## JONHON

«JONHON» (основан в 1970 г.)

Разъемы специального, военного и аэрокосмического назначения:

(Применяются в военной, авиационной, аэрокосмической, морской, железнодорожной, горно- и нефтедобывающей отраслях промышленности)

«FORSTAR» (основан в 1998 г.)

ВЧ соединители, коаксиальные кабели, кабельные сборки и микроволновые компоненты:

(Применяются в телекоммуникациях гражданского и специального назначения, в средствах связи, РЛС, а так же военной, авиационной и аэрокосмической отраслях промышленности).



Телефон: 8 (812) 309-75-97 (многоканальный)

Факс: 8 (812) 320-03-32

Электронная почта: [ocean@oceanchips.ru](mailto:ocean@oceanchips.ru)

Web: <http://oceanchips.ru/>

Адрес: 198099, г. Санкт-Петербург, ул. Калинина, д. 2, корп. 4, лит. А