

Description

The eFuse is a 5V protection device with a bidirectional switch that incorporates input slew rate control to reduce input surge current and reverse current detection to prevent discharge to VCC from VOUT. The eFuse protection features include under voltage lockout, a fixed 2.5A current limit, trimmed fast response over voltage protection and thermal shutdown. The EN/FAULT line is a tri-state bidirectional interface that can be used to disable the output by pulling the line low through an external open drain device. If a thermal fault occurs, the voltage on the pin will go to an intermediate voltage indicating a fault and it can be connected to another device to cause simultaneous shut down. The SAS pin is an ESD protected interface that allows direct external control of the eFuse. Driving the SAS pin high pulls the enable line low causing the eFuse to shutdown and enter a low quiescent current state.

The integrated Isfet latches off when the reverse current is detected. This can be reset only by triggering the under voltage lock out, by EN/FAULT pin or when voltage on the output pin (VOUT) falls below the supply pin voltage (VCC) in AP91352.

The AP91352 is available in a standard Green W-QFN3020-12 package and is RoHS compliant.

Features

- SAS Disable
 - 2.1V Signal Disables the eFuse
 - ESD Compliant to 1kV HBM and 500V CDM
- Integrated Isfet that latches off when reverse current is detected. Latch off is reset by
 - VOUT Falling below VCC
 - UVLO Trigger
 - EN/FAULT Pin
- Input Tolerant of Continuous +12V
- 50mΩ Typical Total on Resistance
- Fixed 2.5A Over Current Protection (OCP)
- Over Voltage Protection (OVP)
- Fixed 13ms +/- 20% Slew Rate Control (SRC)
- Over Temperature Protection (OTP)
- Under Voltage Lockout (UVLO)
- Thermally Efficient Low Profile Package, W-QFN3020-12
- **Totally Lead-Free & Fully RoHS Compliant (Notes 1 & 2)**
- **Halogen and Antimony Free. "Green" Device (Note 3)**

Pin Assignments

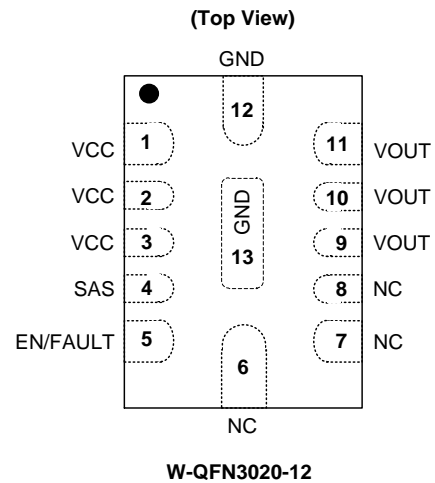

Applications

- HDD Drives
- SSD Drives
- Mother Board Power Management
- Printer Load Power Management
- Fan Drives

Notes:

1. No purposely added lead. Fully EU Directive 2002/95/EC (RoHS) & 2011/65/EU (RoHS 2) compliant.
2. See http://www.diodes.com/quality/lead_free.html for more information about Diodes Incorporated's definitions of Halogen- and Antimony-free, "Green" and Lead-free.
3. Halogen- and Antimony-free "Green" products are defined as those which contain <900ppm bromine, <900ppm chlorine (<1500ppm total Br + Cl) and <1000ppm antimony compounds.

Typical Applications Circuit

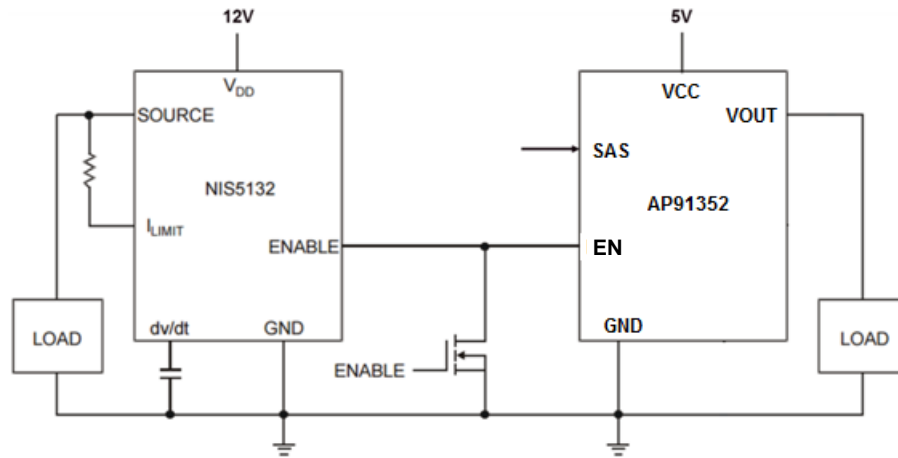

Pin Descriptions

Pin Number	Pin Name	Description
1, 2, 3	VCC	Supply input, a 1 μ F capacitor is needed to supply internal charge pump. The capacitor return should be connected directly to the GND pin.
4	SAS	SAS Disable, When this pin is pulled high to a voltage greater then 2.1V, the eFuse is turned off.
5	EN/FAULT	The EN/FAULT pin is a tri-state, bidirectional interface. It can be used to enable or disable the output of the device by pulling it to ground using an open drain device. If a thermal fault occurs, the voltage on this pin will go to an intermediate state to signal a monitoring circuit that the device is in thermal shutdown. It can also be connected to another device in this family to cause a simultaneous shutdown during thermal events.
6, 7, 8	NC	Do not connect on PCB, internally connected for production purpose
9, 10, 11	VOUT	Output: eFuse controlled output; a 20 μ F capacitor is needed for over voltage protection stability. The capacitor return should be connected directly to the GND pin.
12	GND	Ground
13	GND	Ground exposed pad

NEW PRODUCT

Functional Block Diagram

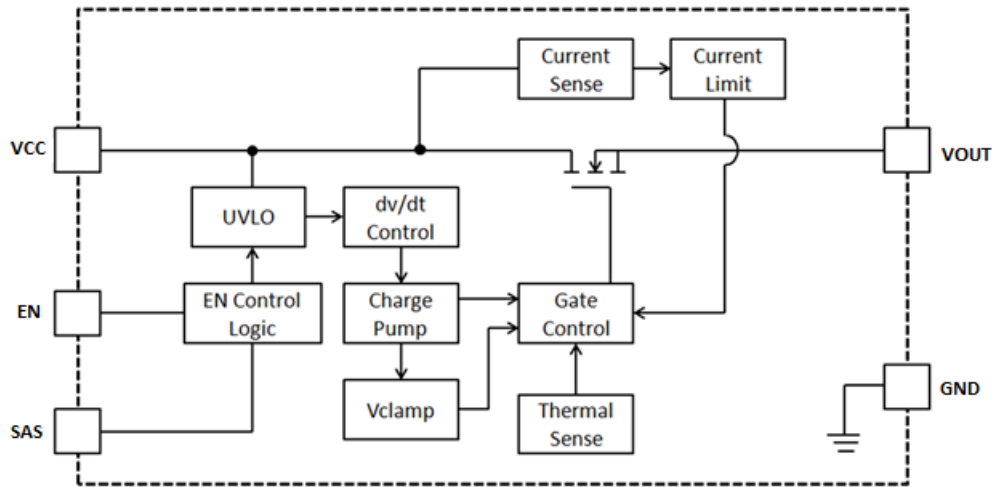

Absolute Maximum Ratings (Note 4) (@ $T_A = +25^\circ\text{C}$, unless otherwise specified.)

Symbol	Parameter		Ratings	Units
VCC	Input Voltage	Steady State	-0.3 to 12	V
		Transient (100ms)	-0.3 to 15	
EN/FAULT	Enable Voltage		-0.3 to 6	V
SAS	SAS Disable Voltage		-0.3 to 3.6	V
VOUT	VOUT Voltage		-0.3 to 7.0	V
ESD HBM	Human Body ESD Protection JESD22-A114		2000	V
ESD CDM	Charged Device Model ESD Protection JESD22-C101		1000	V
$T_{A(max)}$	Maximum Ambient Temperature		-40 to +125	$^\circ\text{C}$
$T_{J(max)}$	Maximum Junction Temperature		+150	$^\circ\text{C}$
T_{ST}	Storage Temperature		-65 to +150	$^\circ\text{C}$
P_D	Power Dissipation ($T_A = +25^\circ\text{C}$)	W-QFN3020-12	1.3	W
$R_{\theta JA}$	Thermal Resistance, Junction to Ambient (0.5 sq in)	W-QFN3020-12 (Note 5)	40	$^\circ\text{C/W}$

- Notes:
- Stresses greater than the 'Absolute Maximum Ratings' specified above may cause permanent damage to the device. These are stress ratings only; functional operation of the device at these or any other conditions exceeding those indicated in this specification is not implied. Device reliability may be affected by exposure to absolute maximum rating conditions for extended periods of time.
 - For a device surface mounted on 25mm by 25mm by 1.6mm FR4 PCB with high coverage of single sided 2oz copper, in still air conditions; the device is measured when operating in a steady state condition.

Recommended Operating Conditions (All specifications are for $-10^\circ\text{C} < T_A < +85^\circ\text{C}$, $V_{CC} = 5\text{V}$, unless otherwise noted.)

Symbol	Parameter	Min	Typ	Max	Units
VCC	Input Voltage Range	3.6	–	12	V
T_A	Operating Ambient Temperature	-40	–	+85	$^\circ\text{C}$

Electrical Characteristics (Note 6) (All specifications are for $-10^{\circ}\text{C} < T_A < +85^{\circ}\text{C}$, $V_{CC} = 5\text{V}$, unless otherwise noted.)

Symbol	Parameters	Conditions	Min	Typ	Max	Unit
Supply Current						
I _Q	VCC Supply Current	EN = High, SAS = 0, I _{LOAD} = 0A	–	–	300	μA
		Fault Latch off	–	100	–	μA
		EN = Low	–	–	100	μA
Power FET						
R _{DS(ON)}	ON Resistance	T _A = +25°C	–	50	65	mΩ
		T _J = +80°C	–	95	–	mΩ
t _{ON-DLY}	Turn-on Delay	Enable I _D = 100mA, 1A Resistive Load	–	500	–	μs
I _{DC}	Continuous Current	T _A = +25°C, 0.5 sq in copper	–	2	–	A
I _{OFF}	Off State Leakage	VCC = 12V, EN = Low	–	–	1	μA
Slew Rate Control						
SRC	Slew Rate Control	EN to VOUT = 4.7V (Note 7)	10.4	13.0	15.6	ms
Current Protection						
I _{LIM}	Current Limit	–	2.5	3.0	–	A
I _{SHORT}	Short Circuit Current	–	–	3.0	–	A
t _{LIM}	Current Limit Response	–	5.5	–	40	μs
Reverse Current Limit / Under Voltage Protection						
I _{QREVERSE}	Fast Reverse Current Limit	(Note 8)	1	–	1.7	A
t _{QREVERSE}	Fast Reverse Current Limit Response Time	VCC dv/dt = -5V/1ms	5	–	10	μs
UVLO	Under Voltage Lock Out	UVLO Rising	3.8	4.0	4.2	V
UVLO-hys	Under Voltage Hysteresis	–	–	0.3	–	V
–	Under Voltage Response	–	–	2.0	–	μs
Over Voltage Protection						
OVP	Over Voltage Clamping	–	5.5	6	6.25	V
t _{OVP}	Over Voltage Response	C _{OUT} = 20μF, dv/dt (VCC) = 0.5V/μs, VOUT < 6.5V	–	20	40	μs
Thermal Protection						
THSD	Shutdown Temperature	–	+130	+150	+200	°C
Enable/Fault						
V _L	Logic Level Low	Output Disabled (Note 7)	0.35	–	0.8	V
V _M	Logic Level Mid	Thermal Fault, Output Disabled (Note 7)	0.9	–	1.95	V
V _H	Logic Level High	Output Enabled	2.1	–	3.3	V
V _{MAX}	Maximum High State	–	3.4	–	5.2	V
I _L	Logic Low Sink Current	EN = 0V	–	-12	-20	μA
I _H	Logic Level High	EN = 3.3V	–	–	1	μA
FAN	Fan out	–	–	–	3	Units

Electrical Characteristics (Cont.) (Note 6) (All specifications are for $-10^{\circ}\text{C} < T_A < +85^{\circ}\text{C}$, $V_{CC} = 5\text{V}$, unless otherwise noted.)

Symbol	Parameters	Conditions	Min	Typ	Max	Unit
SAS Disable						
SAS _L	Logic Level Low	Output Enabled	0.35	–	1.2	V
SAS _H	Logic Level High	Output Disabled	1.3	1.9	2.1	V
SAS _{Hmax}	Maximum Pin Voltage	–	–	–	3.3	V
SAS- _{QIN}	Input Impedance	To GND	350	500	1000	kΩ
SAS-TDLY	Degitch Filter	–	2	–	50	μs
–	Human Body JESD22-A114	–	1	–	–	kV
–	Charged Device JESD22-C101	–	500	–	–	V

- Notes:
6. Typical data is measured at $T_A = +25^{\circ}\text{C}$, $V_{CC} = 5\text{V}$. The maximum and minimum parameters values over operating temperature range are not tested in production, they are guaranteed by design, characterization and process control.
 7. The slew rate control is held in reset until the input voltage is greater than the UVLO rising threshold and Enable = High. The slew rate control is reset when input voltage drops below UVLO falling threshold, Enable changes from High to Mid or Low, SA = High or reverse current detection.
 8. Reverse current detection will latch off the Isofet switch; In AP91352, this condition can be reset by under voltage lock out, by EN/FAULT and SAS pin, or when VOUT falls below the supply pin voltage (V_{CC}) by 100mV typical at $T_A = +25^{\circ}\text{C}$, $V_{CC} = 5\text{V}$.

Performance Characteristic

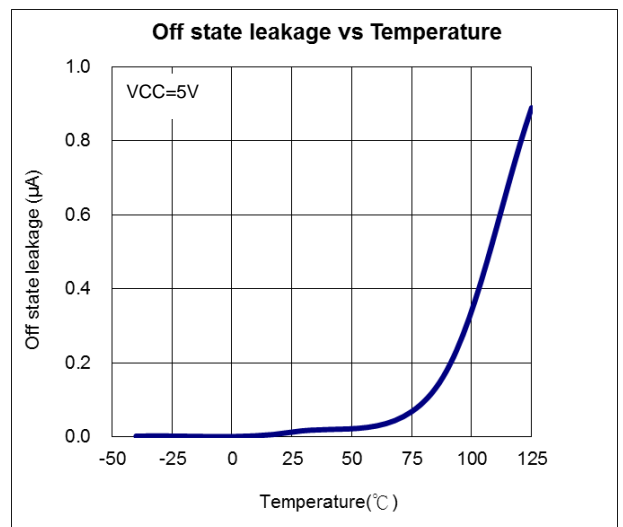
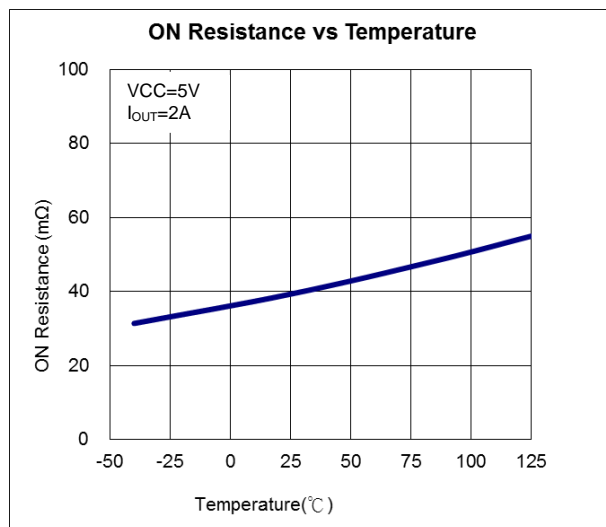
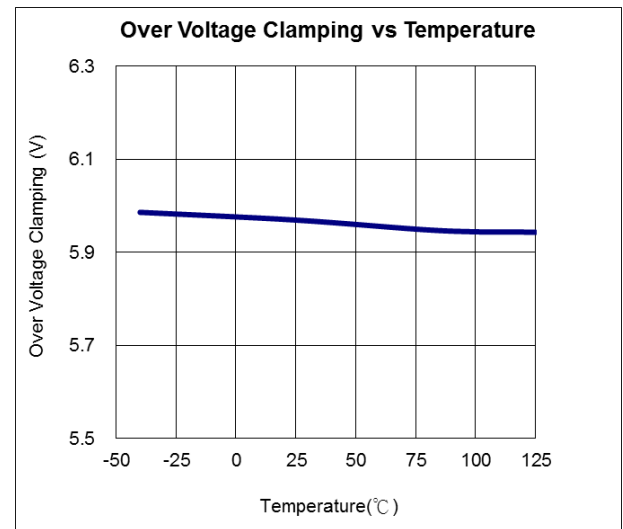
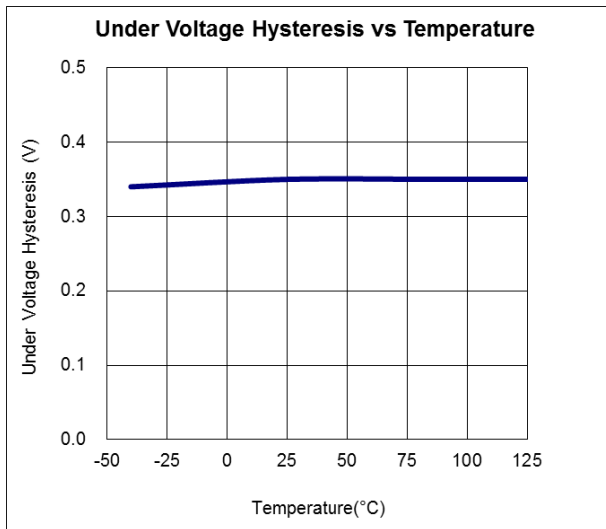
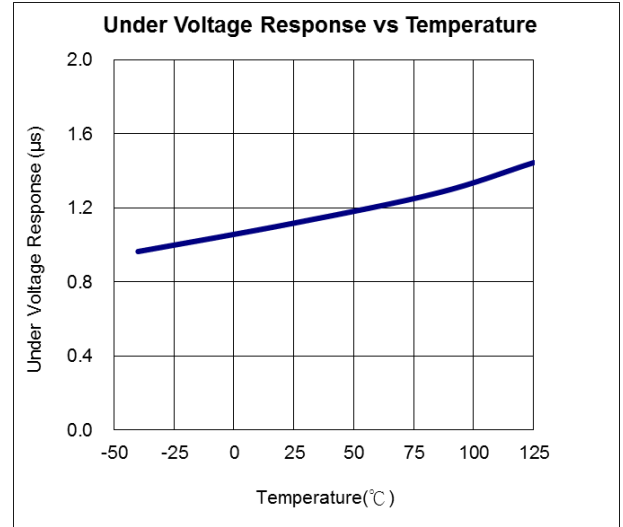
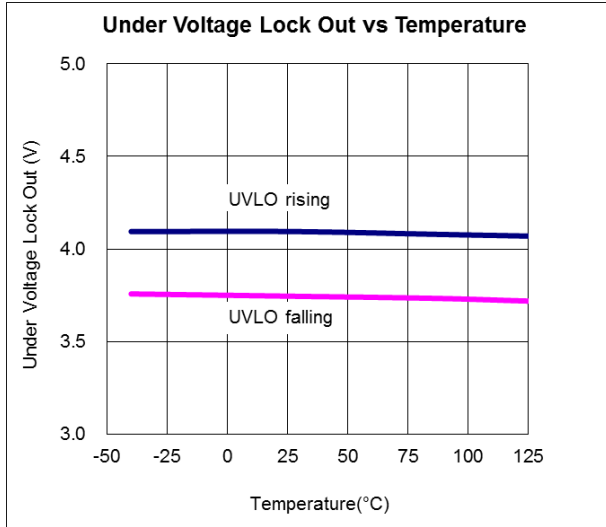

Performance Characteristic (Cont.)

NEW PRODUCT

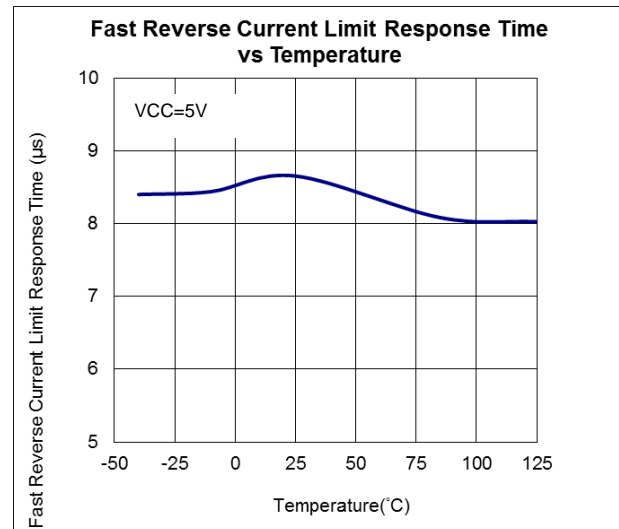
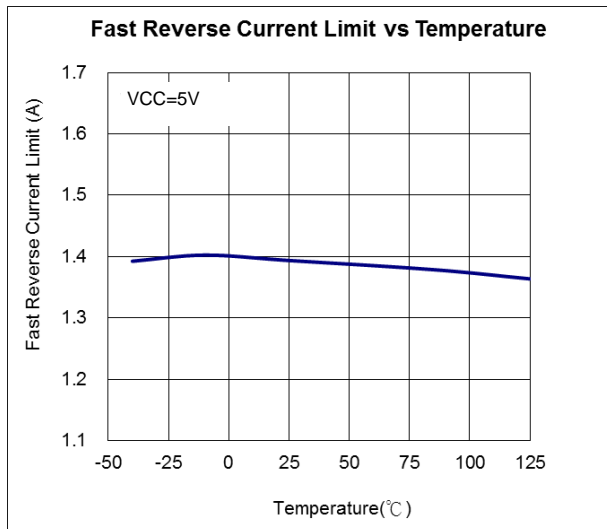
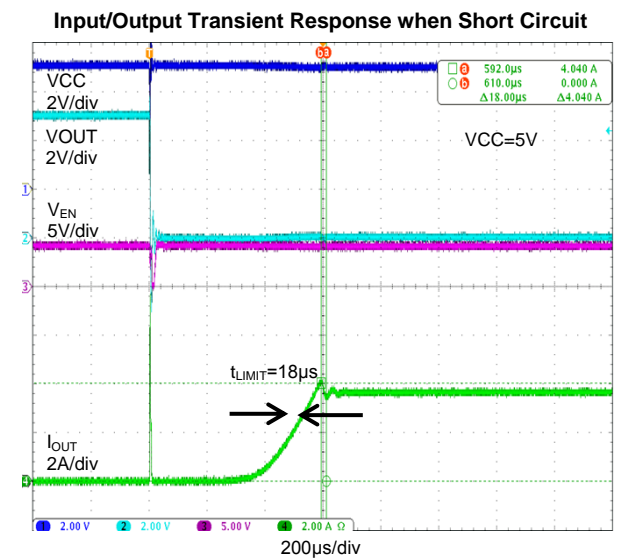
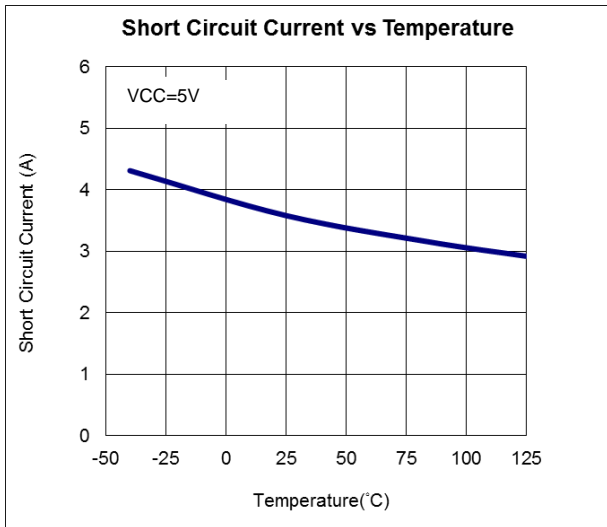
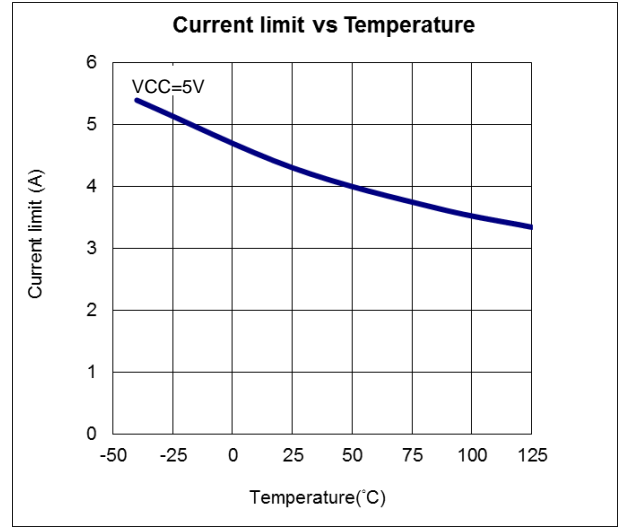
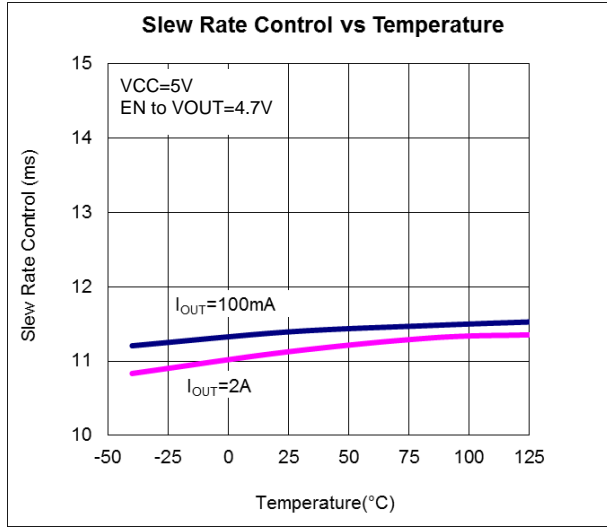

Application Note

Theory of Operation

The AP91352 is a self protected, resettable electronic fuse. It monitors the input and output voltage, the output current and the die temperature. When the AP91352 is powered up it will ramp up the output voltage based on the fixed slew rate (see above electrical spec) and current will begin to flow. The Overcurrent Protection, Overvoltage Clamp, Under Voltage Lockout and Thermal Protection are internally set.

Also, integrated reverse blocking MOSFET would prevent back-drive from an active load inadvertently causing undetermined behavior in the application.

Overvoltage Clamping

The AP91352 monitor the input voltage and clamp output voltage once it exceeds 6.25V (MAX). This will allow for transient on the input for short periods of time. If the input voltage stays above 6.25V (MAX) for extended times the voltage drop across the FET with the load current will increase the die temperature and the thermal shutdown feature will protect the device and shut it down.

Under Voltage Lock Out

The input voltage of AP91352 is monitored by an UVLO circuit (under voltage lockout) if the input voltage drops below this threshold the output transistor will be pulled into a high impedance state.

Enable/Fault

The AP91352 has a tri state EN/FAULT pin. It is used to turn on and off the device with high and low signals from a GPIO, but can also indicate a thermal fault. When the EN/FAULT pin is pulled low the output is turned off, when the EN/FAULT pin is pulled high the output is turned on. Also, the EN/FAULT pin would be internally pulled high after VCC reach UVLO. In the event of a thermal fault the EN/FAULT pin will be pulled low to an intermediate voltage by an internal circuit. This can be used to chain up to 3 efuse together, like AP91352, NIS5132 (12V effuse), or NIS5135 (5V effuse) together that during a thermal shut down the linked devices turn off as well.

Due to this fault indication capability it should not be connected to any type of logic with an internal pull up device.

AP91352 connected to a 2nd device will latch off until the EN/FAULT pin has been pulled to low and then allowed to go back up to a high signal, or SAS pin has been toggled from High to Low or if the power has been cycled. Once the part starts up again it will go through the start-up ramp determined by the internal circuit, 13ms (typ).

Symbol	Description	Enable/Fault	eFuse State	Latching
UVLO	Under Voltage Lock Out	V _L	Off	No
SAS _H	SAS Disable = 1	V _L	Off	N/A
TH _{SD}	Thermal Shutdown	V _M	Off	Yes
I _{REVERSE}	Reverse Current Protection	V _M	Off	(Note 8)
SAS _O	SAS Disable = Open	V _H	On	N/A
SAS _L	SAS Disable = 0	V _H	On	N/A
–	VCC > UVLO, No Fault	V _H	On	N/A

Table 1. EN/FAULT Signal Levels & Device Status

Thermal Protection

The AP91352 has an integrated temperature sensing circuit that protects the die in the event of over temperature. The trip point has been intentionally set high at +150°C (typ) to allow for increased trip times during high power transient events. The AP91352 will shut down current flow to the output when the die temperature reaches +150°C (typ). The AP91352 will restart after the Enable pin has been toggled or the input power has been cycled.

Even though the thermal trip point has been set high to allow for high current transients the circuit design should accomplish best thermal performance with good thermal layout of the PCB. It is not recommended to operate AP91352 above +150°C over extended periods of time.

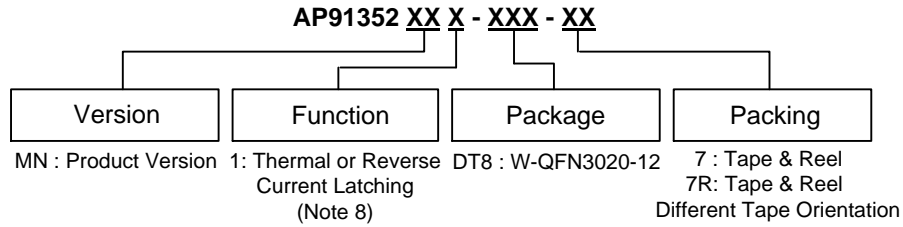
Ordering Information

Part Number	Package Code	Packaging (Note 9)	Identification Code	7" Tape and Reel	
				Quantity	Part Number Suffix
AP91352MN1-DT8-7	DT8	W-QFN3020-12	P9	3000/Tape & Reel	-7
AP91352MN1-DT8-7R	DT8	W-QFN3020-12	P9	3000/Tape & Reel	-7R

Note 9: Pad layout as shown in Diodes Incorporated's package outline PDFs, which can be found on our website at <http://www.diodes.com/package-outlines.html>.

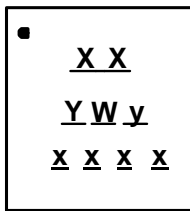
Marking Information**W-QFN3020-12****(Top View)**

- XX : Identification Code
- Y : Year : 0~9
- W : Week : A~Z : 1~26 week; a~z : 27~52 week; z represents 52 and 53 week
- y : Internal Code
- x : Internal Code

Part Number	Package	Identification Code
AP91352MN1-DT8-7	W-QFN3020-12	P9
AP91352MN1-DT8-7R	W-QFN3020-12	P9

Package Outline Dimensions

Please see <http://www.diodes.com/package-outlines.html> for the latest version.

W-QFN3020-12

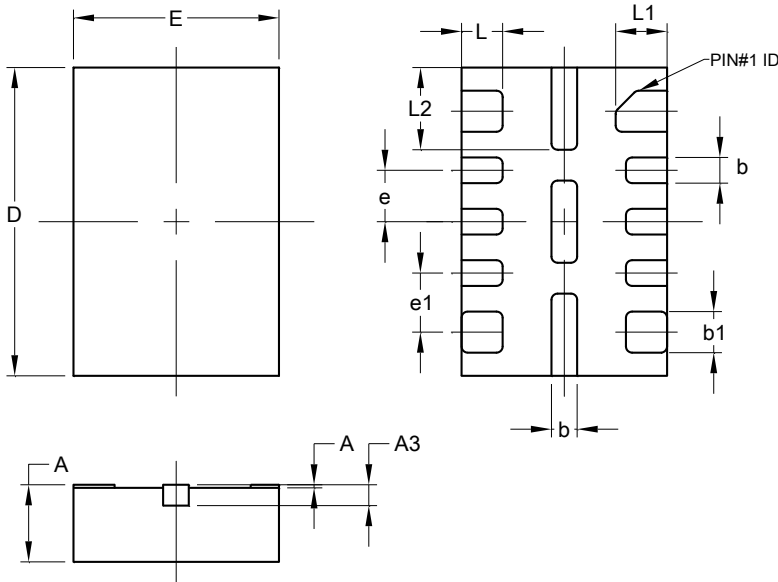

W-QFN3020-12			
Dim	Min	Max	Typ
A	0.700	0.800	-
A1	0	0.05	-
A3	0.203REF		
b	0.200	0.300	-
b1	0.350	0.450	-
D	1.900	2.100	2.000
E	2.900	3.100	3.000
e	-	-	0.500
e1	-	-	0.575
L	0.350	0.450	-
L1	0.450	0.550	-
L2	0.750	0.850	-
All Dimensions in mm			

Suggested Pad Layout

Please see <http://www.diodes.com/package-outlines.html> for the latest version.

W-QFN3020-12

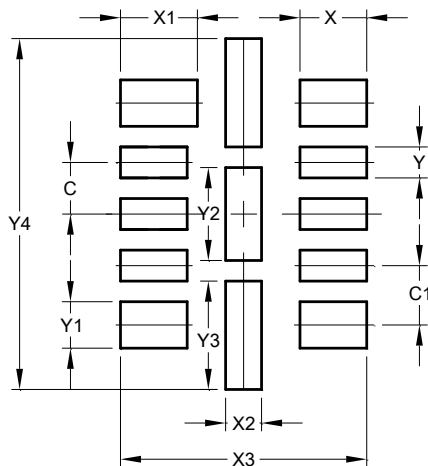

Dimensions	Value (in mm)
C	0.500
G	0.575
X	0.650
X1	0.750
X2	0.350
X3	2.400
Y	0.300
Y1	0.450
Y2	0.900
Y3	1.050
Y4	3.400

Taping Orientation

(1) Package Type: AP91352MN1-DT8-7

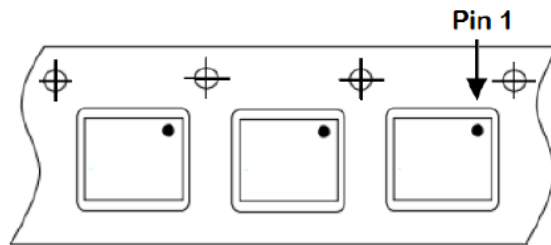

(2) Package Type: AP91352MN1-DT8-7R

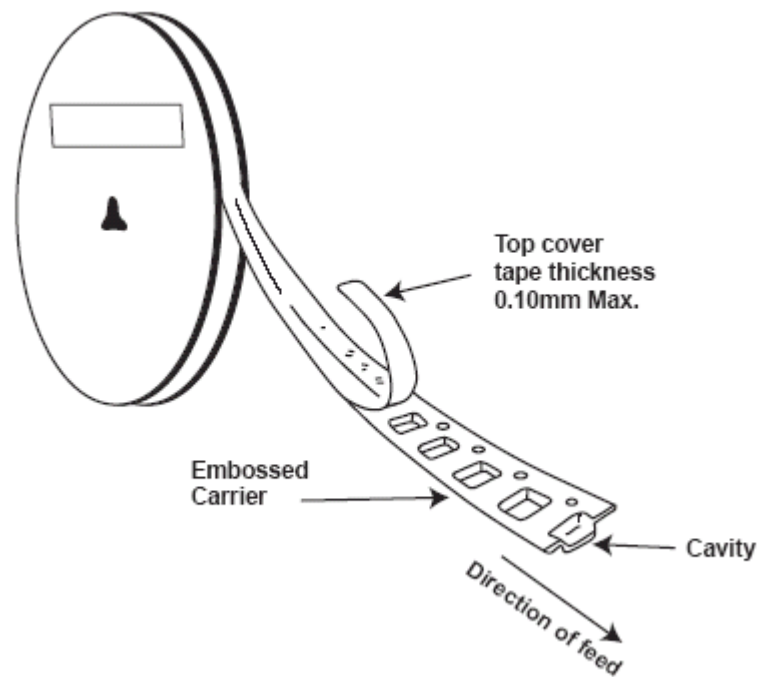
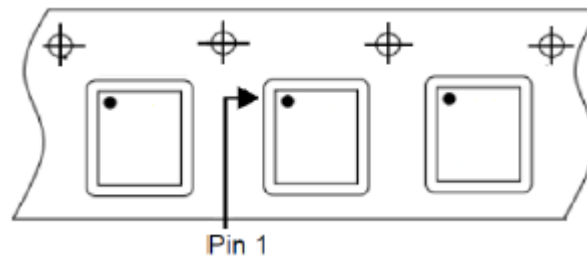

Note 10: The taping orientation of the other package type can be found on our website at <http://www.diodes.com/datasheets/ap02007.pdf>.

IMPORTANT NOTICE

DIODES INCORPORATED MAKES NO WARRANTY OF ANY KIND, EXPRESS OR IMPLIED, WITH REGARDS TO THIS DOCUMENT, INCLUDING, BUT NOT LIMITED TO, THE IMPLIED WARRANTIES OF MERCHANTABILITY AND FITNESS FOR A PARTICULAR PURPOSE (AND THEIR EQUIVALENTS UNDER THE LAWS OF ANY JURISDICTION).

Diodes Incorporated and its subsidiaries reserve the right to make modifications, enhancements, improvements, corrections or other changes without further notice to this document and any product described herein. Diodes Incorporated does not assume any liability arising out of the application or use of this document or any product described herein; neither does Diodes Incorporated convey any license under its patent or trademark rights, nor the rights of others. Any Customer or user of this document or products described herein in such applications shall assume all risks of such use and will agree to hold Diodes Incorporated and all the companies whose products are represented on Diodes Incorporated website, harmless against all damages.

Diodes Incorporated does not warrant or accept any liability whatsoever in respect of any products purchased through unauthorized sales channel. Should Customers purchase or use Diodes Incorporated products for any unintended or unauthorized application, Customers shall indemnify and hold Diodes Incorporated and its representatives harmless against all claims, damages, expenses, and attorney fees arising out of, directly or indirectly, any claim of personal injury or death associated with such unintended or unauthorized application.

Products described herein may be covered by one or more United States, international or foreign patents pending. Product names and markings noted herein may also be covered by one or more United States, international or foreign trademarks.

This document is written in English but may be translated into multiple languages for reference. Only the English version of this document is the final and determinative format released by Diodes Incorporated.

LIFE SUPPORT

Diodes Incorporated products are specifically not authorized for use as critical components in life support devices or systems without the express written approval of the Chief Executive Officer of Diodes Incorporated. As used herein:

A. Life support devices or systems are devices or systems which:

1. are intended to implant into the body, or
2. support or sustain life and whose failure to perform when properly used in accordance with instructions for use provided in the labeling can be reasonably expected to result in significant injury to the user.

B. A critical component is any component in a life support device or system whose failure to perform can be reasonably expected to cause the failure of the life support device or to affect its safety or effectiveness.

Customers represent that they have all necessary expertise in the safety and regulatory ramifications of their life support devices or systems, and acknowledge and agree that they are solely responsible for all legal, regulatory and safety-related requirements concerning their products and any use of Diodes Incorporated products in such safety-critical, life support devices or systems, notwithstanding any devices- or systems-related information or support that may be provided by Diodes Incorporated. Further, Customers must fully indemnify Diodes Incorporated and its representatives against any damages arising out of the use of Diodes Incorporated products in such safety-critical, life support devices or systems.

Copyright © 2016, Diodes Incorporated

www.diodes.com

Компания «Океан Электроники» предлагает заключение долгосрочных отношений при поставках импортных электронных компонентов на взаимовыгодных условиях!

Наши преимущества:

- Поставка оригинальных импортных электронных компонентов напрямую с производств Америки, Европы и Азии, а так же с крупнейших складов мира;
- Широкая линейка поставок активных и пассивных импортных электронных компонентов (более 30 млн. наименований);
- Поставка сложных, дефицитных, либо снятых с производства позиций;
- Оперативные сроки поставки под заказ (от 5 рабочих дней);
- Экспресс доставка в любую точку России;
- Помощь Конструкторского Отдела и консультации квалифицированных инженеров;
- Техническая поддержка проекта, помощь в подборе аналогов, поставка прототипов;
- Поставка электронных компонентов под контролем ВП;
- Система менеджмента качества сертифицирована по Международному стандарту ISO 9001;
- При необходимости вся продукция военного и аэрокосмического назначения проходит испытания и сертификацию в лаборатории (по согласованию с заказчиком);
- Поставка специализированных компонентов военного и аэрокосмического уровня качества (Xilinx, Altera, Analog Devices, Intersil, Interpoint, Microsemi, Actel, Aeroflex, Peregrine, VPT, Syfer, Eurofarad, Texas Instruments, MS Kennedy, Miteq, Cobham, E2V, MA-COM, Hittite, Mini-Circuits, General Dynamics и др.);

Компания «Океан Электроники» является официальным дистрибьютором и эксклюзивным представителем в России одного из крупнейших производителей разъемов военного и аэрокосмического назначения «JONHON», а так же официальным дистрибьютором и эксклюзивным представителем в России производителя высокотехнологичных и надежных решений для передачи СВЧ сигналов «FORSTAR».



JONHON

«JONHON» (основан в 1970 г.)

Разъемы специального, военного и аэрокосмического назначения:

(Применяются в военной, авиационной, аэрокосмической, морской, железнодорожной, горно- и нефтедобывающей отраслях промышленности)

«FORSTAR» (основан в 1998 г.)

ВЧ соединители, коаксиальные кабели,
кабельные сборки и микроволновые компоненты:

(Применяются в телекоммуникациях гражданского и специального назначения, в средствах связи, РЛС, а так же военной, авиационной и аэрокосмической отраслях промышленности).



Телефон: 8 (812) 309-75-97 (многоканальный)

Факс: 8 (812) 320-03-32

Электронная почта: ocean@oceanchips.ru

Web: <http://oceanchips.ru/>

Адрес: 198099, г. Санкт-Петербург, ул. Калинина, д. 2, корп. 4, лит. А