



**TISP8210MD BUFFERED P-GATE SCR DUAL
TISP8211MD BUFFERED N-GATE SCR DUAL**

**COMPLEMENTARY BUFFERED-GATE SCRS
FOR DUAL POLARITY SLIC OVERVOLTAGE PROTECTION**

TISP821xMD Overvoltage Protectors

High Performance Protection for SLICs with +ve & -ve Battery Supplies

TISP8210MD Negative Overvoltage Protector
 – Wide 0 to -110 V Programming Range
 – Low +5 mA Max. Gate Triggering Current
 – High -150 mA Min. Holding Current

TISP8211MD Positive Overvoltage Protector
 – Wide 0 to +110 V Programming Range
 – Low -5 mA Max. Gate Triggering Current
 – +20 mA Min. Holding Current

Rated for International Surge Wave Shapes

Wave Shape	Standard	I _{PPSM} A
2/10	GR-1089-CORE	167
10/700	ITU-T K.20/21/45	70
10/1000	GR-1089-CORE	60

.....UL Recognized Component

Circuit Application Diagram

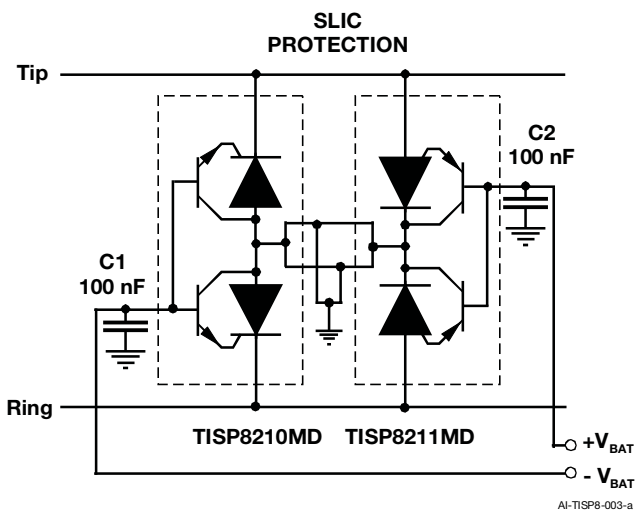

TISP8210MD 8-SOIC Package (Top View)

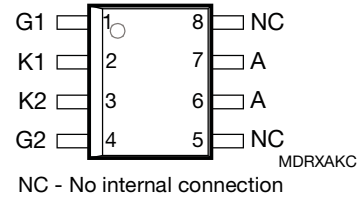

TISP8210MD Device Symbol

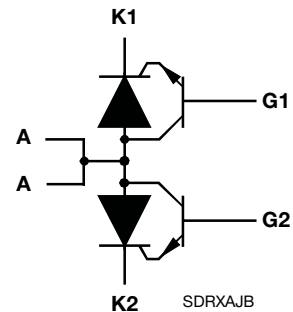

TISP8211MD 8-SOIC Package (Top View)

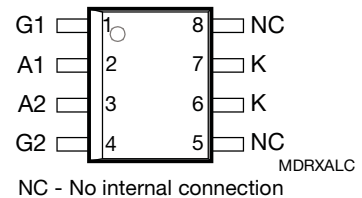

TISP8211MD Device Symbol

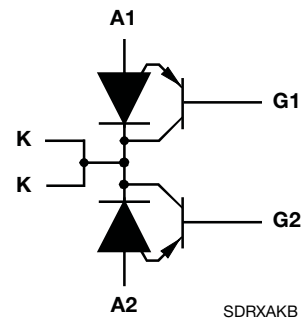

*RoHS Directive 2002/95/EC Jan 27 2003 including Annex
 JANUARY 2006 - REVISED MAY 2007
 Specifications are subject to change without notice.
 Customers should verify actual device performance in their specific applications.

TISP821xMD Overvoltage Protectors

BOURNS®

Description

The TISP8210MD / TISP8211MD protector combination has been designed to protect dual polarity supply rail SLICs (Subscriber Line Interface Circuits) against overvoltages on the telephone line caused by lightning and a.c. power contact and induction. Both devices have been designed using the latest understanding of programmable protector technology to maximize performance.

The TISP8210MD and TISP8211MD are complementary programmable protection devices. The program or gate pins (G1, G2) are connected to the positive and negative SLIC battery supplies to give protection which will track the SLIC supply levels. The integrated transistor buffer is an essential element in this type of device as the current gain of around 150 reduces battery loading to below 5 mA during a.c. power induction or power contact conditions. Additionally the Base-Emitter junction acts as a reverse blocking diode during operation preventing unnecessary loading of the power supply.

The TISP8210MD / TISP8211MD combination is designed to be used in conjunction with the 12.5 Ω Bourns® 4A12P-1AH-12R5 Line Protection Module (LPM). With this solution the application should pass Telcordia GR-1089-CORE testing with the 4A12P-1AH-12R5 acting as the overcurrent protector and coordination element.

The TISP® device plus LPM solution is designed to work in harmony with the system primary protectors. GR-1089-CORE issue 3 lists test to allow for three types of primary protection: Carbon Block (1000 V); Gas Discharge Tube (600 V) and Solid State (400 V). This solution is designed to be used with the GDT and Solid State options. Under lightning conditions the current through the 12.5 Ω LPM will be 48 A (600 V / 12.5 Ω), which is well within the 60 A capability of the TISP8210MD / TISP8211MD combination.

How to Order

Device	Package	Carrier	Order As	Marking Code	Standard Quantity
TISP8210MD	8-SOIC	Embossed Tape Reeled	TISP8210MDR-S	8210M	2500
TISP8211MD			TISP8211MDR-S	8211M	

TISP8210MD Absolute Maximum Ratings, $T_A = 25^\circ\text{C}$

Rating	Symbol	Value	Unit
Repetitive peak off-state voltage, $V_{GK} = 0$	V_{DRM}	-120	V
Repetitive peak reverse voltage, $V_{GA} = -70$ V	V_{RRM}	120	
Non-repetitive peak impulse current (see Note 1) 2/10 μs (Telcordia GR-1089-CORE, 2/10 μs voltage wave shape) 5/310 μs (ITU-T K.44, 10/700 μs voltage wave shape used in K.20/21/45) 10/1000 μs (Telcordia GR-1089-CORE, 10/1000 μs voltage wave shape)	I_{PPSM}	-167 -70 -60	A
Non-repetitive peak on-state current, 50/60 Hz (see Notes 1 and 2) 100 ms 1 s 5 s 300 s 900 s	I_{TSM}	-11 -6.5 -3.4 -1.4 -1.3	A
Junction temperature	T_J	-55 to +150	$^\circ\text{C}$
Storage temperature range	T_{stg}	-65 to +150	$^\circ\text{C}$

- NOTES: 1. Initially the protector must be in thermal equilibrium with $T_J = 25^\circ\text{C}$. The surge may be repeated after the device returns to its initial conditions.
2. These non-repetitive rated terminal currents are for the TISP8210MD and TISP8211MD together. Device (A)-terminal positive current values are conducted by the TISP8211MD and (K)-terminal negative current values by the TISP8210MD.

TISP821xMD Overvoltage Protectors

BOURNS®

TISP8211MD Absolute Maximum Ratings, $T_A = 25\text{ }^\circ\text{C}$

Rating	Symbol	Value	Unit
Repetitive peak off-state voltage, $V_{GA} = 0$	V_{DRM}	120	V
Repetitive peak reverse voltage, $V_{GK} = 70\text{ V}$	V_{RRM}	-120	
Non-repetitive peak impulse current (see Note 3) 2/10 μs (Telcordia GR-1089-CORE, 2/10 μs voltage wave shape) 5/310 μs (ITU-T K.44, 10/700 μs voltage wave shape used in K.20/21/45) 10/1000 μs (Telcordia GR-1089-CORE, 10/1000 μs voltage wave shape)	I_{PPSM}	167 70 60	A
Non-repetitive peak on-state current, 50/60 Hz (see Notes 3 and 4) 100 ms 1 s 5 s 300 s 900 s	I_{TSM}	11 6.5 3.4 1.4 1.3	A
Junction temperature	T_J	-55 to +150	$^\circ\text{C}$
Storage temperature range	T_{stg}	-65 to +150	$^\circ\text{C}$

NOTES: 3. Initially the protector must be in thermal equilibrium with $T_J = 25\text{ }^\circ\text{C}$. The surge may be repeated after the device returns to its initial conditions.

4. These non-repetitive rated terminal currents are for the TISP8210MD and TISP8211MD together. Device (A)-terminal positive current values are conducted by the TISP8211MD and (K)-terminal negative current values by the TISP8210MD.

Recommended Operating Conditions

See Figure 3		Min	Typ	Max	Unit
C1, C2	Gate decoupling capacitor	100	220		nF
R1, R2	Series resistance for Telcordia GR-1089-CORE	10	12.5		Ω

TISP8210MD Electrical Characteristics, $T_A = 25\text{ }^\circ\text{C}$

Parameter	Test Conditions	Min	Typ	Max	Unit
I_{DRM} Repetitive peak off-state current	$V_D = V_{DRM}$, $V_{GK} = 0$			-5	μA
I_{RRM} Repetitive peak reverse current	$V_R = V_{RRM}$, $V_{GA} = -70\text{ V}$			5	μA
$V_{(BO)}$ Breakover voltage	$dv/dt = -250\text{ V/ms}$, $R_{SOURCE} = 300\ \Omega$, $V_{GA} = -80\text{ V}$			-82	V
I_H Holding current	(I _K) $I_T = -1\text{ A}$, $di/dt = 1\text{ A/ms}$, $V_{GA} = -80\text{ V}$	-150			mA
I_{GT} Gate trigger current	(I _K) $I_T = -5\text{ A}$, $t_{p(g)} \geq 20\ \mu\text{s}$, $V_{GA} = -80\text{ V}$			5	mA
C_O Off-state capacitance	$f = 1\text{ MHz}$, $V_d = 1\text{ V}$, $V_D = \pm 2\text{ V}$			40	pF

TISP8211MD Electrical Characteristics, $T_A = 25\text{ }^\circ\text{C}$

Parameter	Test Conditions	Min	Typ	Max	Unit
I_{DRM} Repetitive peak off-state current	$V_D = V_{DRM}$, $V_{GA} = 0$			5	μA
I_{RRM} Repetitive peak reverse current	$V_R = V_{RRM}$, $V_{GK} = 70\text{ V}$			-5	μA
$V_{(BO)}$ Breakover voltage	$dv/dt = 250\text{ V/ms}$, $R_{SOURCE} = 300\ \Omega$, $V_{GK} = 80\text{ V}$			82	V
I_H Holding current	(I _A) $I_T = 1\text{ A}$, $di/dt = -1\text{ A/ms}$, $V_{GK} = 80\text{ V}$	20			mA
I_{GT} Gate trigger current	(I _A) $I_T = 5\text{ A}$, $t_{p(g)} \geq 20\ \mu\text{s}$, $V_{GK} = 80\text{ V}$			-5	mA
C_O Off-state capacitance	$f = 1\text{ MHz}$, $V_d = 1\text{ V}$, $V_D = \pm 2\text{ V}$			30	pF

Thermal Characteristics

Parameter	Test Conditions	Min	Typ	Max	Unit
$R_{\theta JA}$ Junction to ambient thermal resistance	$P_{tot} = 0.52\text{ W}$, $T_A = 70\text{ }^\circ\text{C}$, 5 cm^2 , FR4 PCB			160	$^\circ\text{C/W}$

JANUARY 2006 - REVISED MAY 2007

Specifications are subject to change without notice.

Customers should verify actual device performance in their specific applications.

Parameter Measurement Information

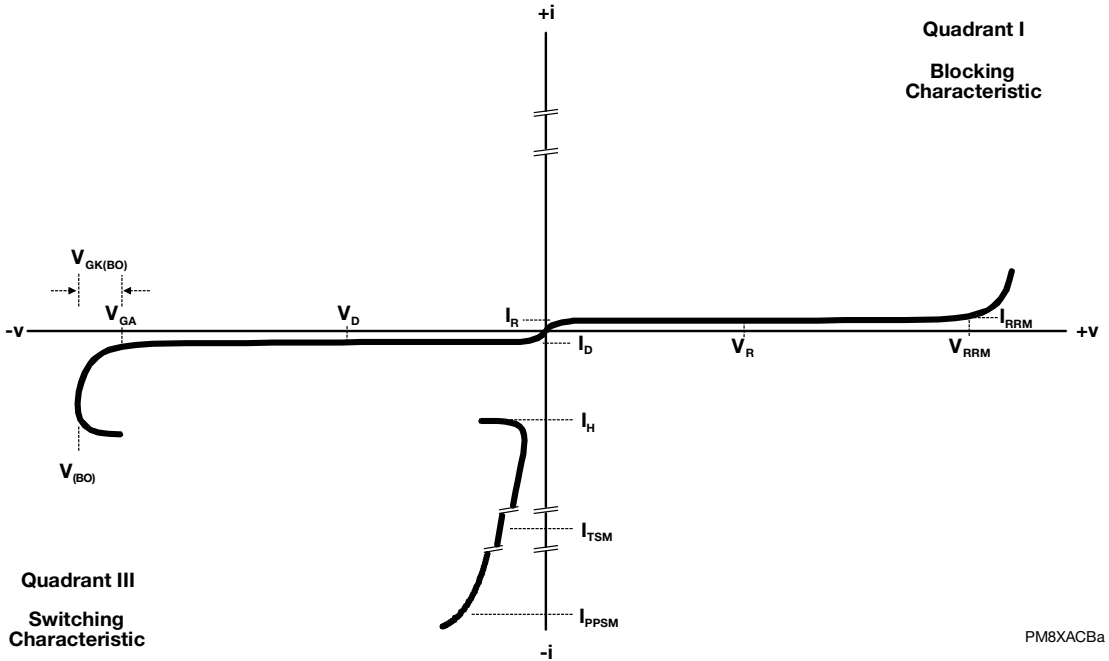

Figure 1. TISP8210MD KA Terminal Characteristic

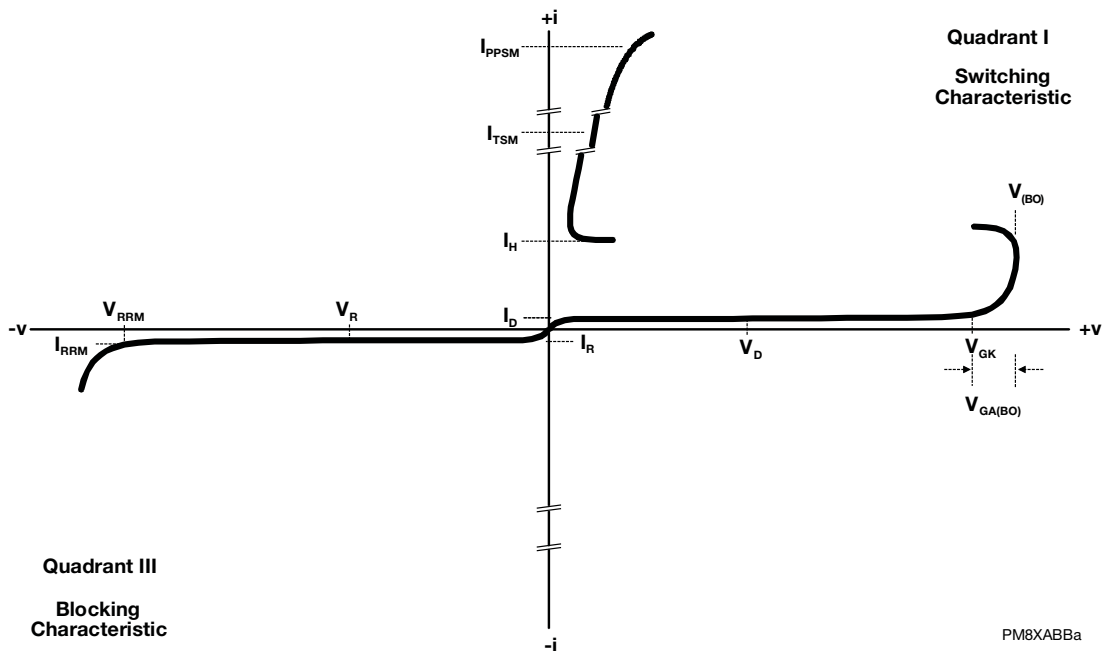
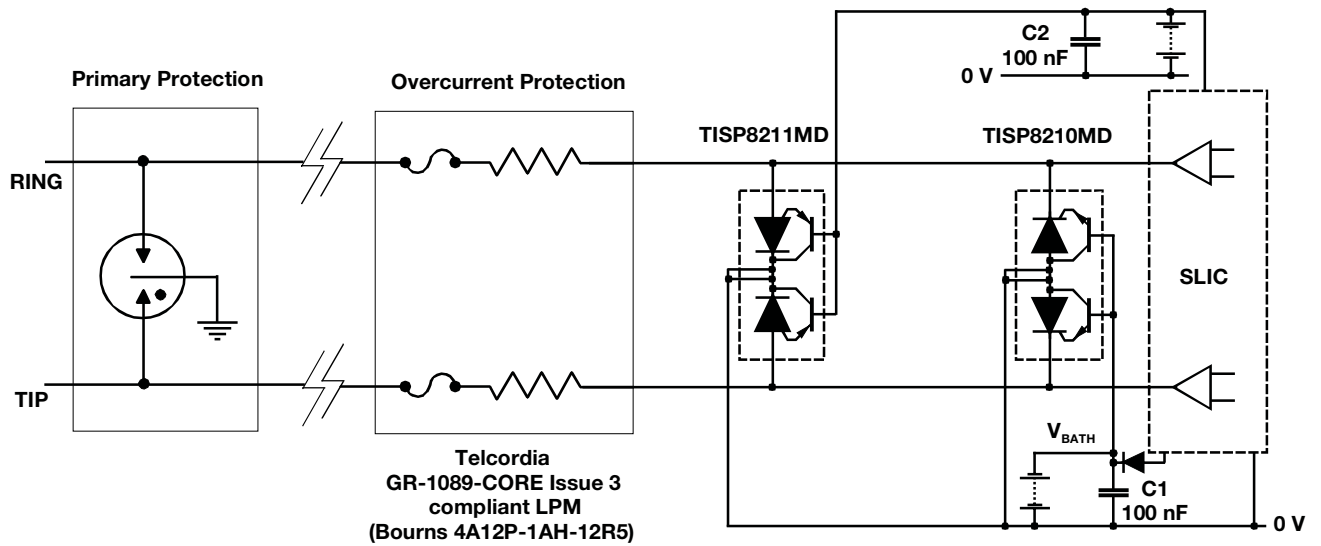

Figure 2. TISP8211MD AK Terminal Characteristic

TISP821xMD Overvoltage Protectors

BOURNS[®]

Applications Information



AI-TISP8-004-a

Figure 3. Typical Application Circuit

Bourns Sales Offices

<u>Region</u>	<u>Phone</u>	<u>Fax</u>
The Americas:	+1-951-781-5500	+1-951-781-5700
Europe:	+41-41-7685555	+41-41-7685510
Asia-Pacific:	+886-2-25624117	+886-2-25624116

Technical Assistance

<u>Region</u>	<u>Phone</u>	<u>Fax</u>
The Americas:	+1-951-781-5500	+1-951-781-5700
Europe:	+41-41-7685555	+41-41-7685510
Asia-Pacific:	+886-2-25624117	+886-2-25624116

www.bourns.com

Bourns® products are available through an extensive network of manufacturer's representatives, agents and distributors. To obtain technical applications assistance, a quotation, or to place an order, contact a Bourns representative in your area.



Reliable Electronic Solutions

"TISP" is a trademark of Bourns, Ltd., a Bourns Company, and is Registered in U.S. Patent and Trademark Office.
"Bourns" is a registered trademark of Bourns, Inc. in the U.S. and other countries.

COPYRIGHT© 2006, BOURNS, INC. LITHO IN U.S.A. e 03/06 TSP0610

JANUARY 2006 - REVISED MAY 2007

Specifications are subject to change without notice.
Customers should verify actual device performance in their specific applications.

Компания «Океан Электроники» предлагает заключение долгосрочных отношений при поставках импортных электронных компонентов на взаимовыгодных условиях!

Наши преимущества:

- Поставка оригинальных импортных электронных компонентов напрямую с производств Америки, Европы и Азии, а так же с крупнейших складов мира;
- Широкая линейка поставок активных и пассивных импортных электронных компонентов (более 30 млн. наименований);
- Поставка сложных, дефицитных, либо снятых с производства позиций;
- Оперативные сроки поставки под заказ (от 5 рабочих дней);
- Экспресс доставка в любую точку России;
- Помощь Конструкторского Отдела и консультации квалифицированных инженеров;
- Техническая поддержка проекта, помощь в подборе аналогов, поставка прототипов;
- Поставка электронных компонентов под контролем ВП;
- Система менеджмента качества сертифицирована по Международному стандарту ISO 9001;
- При необходимости вся продукция военного и аэрокосмического назначения проходит испытания и сертификацию в лаборатории (по согласованию с заказчиком);
- Поставка специализированных компонентов военного и аэрокосмического уровня качества (Xilinx, Altera, Analog Devices, Intersil, Interpoint, Microsemi, Actel, Aeroflex, Peregrine, VPT, Syfer, Eurofarad, Texas Instruments, MS Kennedy, Miteq, Cobham, E2V, MA-COM, Hittite, Mini-Circuits, General Dynamics и др.);

Компания «Океан Электроники» является официальным дистрибьютором и эксклюзивным представителем в России одного из крупнейших производителей разъемов военного и аэрокосмического назначения «JONHON», а так же официальным дистрибьютором и эксклюзивным представителем в России производителя высокотехнологичных и надежных решений для передачи СВЧ сигналов «FORSTAR».



JONHON

«JONHON» (основан в 1970 г.)

Разъемы специального, военного и аэрокосмического назначения:

(Применяются в военной, авиационной, аэрокосмической, морской, железнодорожной, горно- и нефтедобывающей отраслях промышленности)

«FORSTAR» (основан в 1998 г.)

ВЧ соединители, коаксиальные кабели, кабельные сборки и микроволновые компоненты:

(Применяются в телекоммуникациях гражданского и специального назначения, в средствах связи, РЛС, а так же военной, авиационной и аэрокосмической отраслях промышленности).



Телефон: 8 (812) 309-75-97 (многоканальный)

Факс: 8 (812) 320-03-32

Электронная почта: ocean@oceanchips.ru

Web: <http://oceanchips.ru/>

Адрес: 198099, г. Санкт-Петербург, ул. Калинина, д. 2, корп. 4, лит. А