

LT4363-1/LT4363-2

High Voltage Surge Stopper with Current Limit

DESCRIPTION

Demonstration Circuit 1935A showcases the LT[®]4363 surge stopper in a 12V, 2A application. Inputs of up to 80VDC and 1ms transients of up to 250V are limited to 16.3V at the output. The MOSFET is protected against output overloads by current limiting. Sustained overvoltage or overcurrent conditions cause the LT4363 to turn off after a timer delay. The LT4363-1 latches off and is reset by pulling SHDN low for at least 100 μ s. The LT4363-2 automatically retries after a cool down delay; retry is inhibited if OV is higher than 1.275V.

By removing 0 Ω jumpers R1C and R4C, the operation may be modified for 28V systems with an output regulation point of 34.6V in overvoltage conditions.

Design files for this circuit board are available at <http://www.linear.com/demo>

LT, LT, LTC, LTM, Linear Technology and the Linear logo are registered trademarks of Linear Technology Corporation. All other trademarks are the property of their respective owners.

PERFORMANCE SUMMARY $T_A = 25^\circ\text{C}$, R1C = R4C = 0 Ω (As Shipped)

PARAMETER	CONDITIONS	MIN	TYP	MAX	UNITS
Input Supply	Operating	5.7	12	14.7	V
	DC Survival	80			V
	1ms Transient Survival	250			V
Output Regulation Voltage		15.7	16.3	17.0	V
Undervoltage Threshold		5.2	5.6	5.7	V
Retry Inhibit Threshold		14.7	15.5	16.2	V
Current Limit		2.0	2.5	3.1	A

$T_A = 25^\circ\text{C}$, R1C = R4C = Open (Optional Field Change)

PARAMETER	CONDITIONS	MIN	TYP	MAX	UNITS
Input Supply	Operating	12.4	28	31.6	V
	DC Survival	80			V
	1ms Transient Survival	250			V
Output Regulation Voltage		33.2	34.6	35.9	V
Undervoltage Threshold		11.2	11.9	12.4	V
Retry Inhibit Threshold		31.6	33.3	34.9	V
Current Limit		2.0	2.6	3.1	A

QUICK START PROCEDURE

Danger! High voltage testing should be performed by qualified personnel only. As a safety precaution at least two people should be present during high voltage testing.

BOARD LAYOUT

DC1935A is designed to withstand 250V peak input voltage for up to 1ms. This high voltage is stood off by CSNAB, R4A, R7, R10, Q1, Q2 and Q3. Maximum input voltage is limited by Q1's 250V BV_{DSS} rating. The permissible time at 250V is limited by R7, which dissipates slightly less than 40W and is capable of doing so for at least 1ms.

The minimum spacing is limited by 1206 pad spacing where the gap between solder pads is 2mm, or just under 80mils. Thus, the spacing between the input plane and all other board traces is maintained at a minimum of 2mm. As a point of reference, a 2mm needle gap in air breaks down well above 1kV.

250V CAPABILITY

The LT4363 is rated to survive up to 100V. If input spikes did not exceed 100V, the V_{CC} pin could be connected directly to the input. Nevertheless, in some systems input voltage spikes may reach levels much higher than 100V. Operation under these conditions is made possible by limiting the voltage at the V_{CC} pin with an external filter or clamp.

The simplest clamp is a Zener diode or transient voltage suppressor (D1) and a 1k Ω series limiting resistance (R7). This arrangement is adequate for millisecond excursions of up to 250V. The voltage is limited by the breakdown of Q1 and the peak voltage rating of R7, and the time is limited by the pulse power capability of R7, D1, and Q1.

The OV and UV pins are limited to 100V absolute maximum. Practical divider ratios attenuate peak inputs of 250V to safe levels at the OV and UV pins. For the resistors used in DC1935A, the peak voltage at the UV pin is less than 60V when the input spikes to 250V. If there is an input voltage/divider ratio combination that leads to greater than 100V at OV or UV, the top of the divider may be moved to the V_{CC} clamp for protection, with a small penalty in accuracy, or a Zener clamp may be added to the affected pin.

While the input of the DC1935A can handle 250V, several points should be brought to mind. First, the dissipation of several components rises to significant levels when 250V is applied. R4 dissipation rises to near 500mW, D1 dissipates over 10W and R7 dissipates nearly 40W. These components dissipate high, destructive power even though the LT4363 regulates and then shuts down the output, saving the load and Q1 from destruction. The maximum safe DC input is 80V, limited by the dissipation of R7 and D1. Always remember that 250V should be applied only as a spike or transient, not exceeding 1ms duration.

Danger! High voltage testing should be performed by qualified personnel only. As a safety precaution at least two people should be present during high voltage testing.

DC1935A-A AND DC1935A-B STUFFING OPTIONS

The DC1935A-A is fitted with the LT4363-1 which latches off after a timer delay in the presence of overvoltage or overcurrent conditions. Once latched off the LT4363-1 version's timer executes a cool-down cycle, after which the output may be restarted by pulsing the \overline{SHDN} pin low for at least 100 μ s, or by briefly disconnecting the input supply.

The DC1935A-B is fitted with the LT4363-2 which automatically retries after its cool-down cycle. Retry is inhibited by the OV pin, if the input is greater than 15.5V.

OPERATION

The shutdown pin, \overline{SHDN} , is floating so that when power is applied to the input, the LT4363 automatically turns on.

The LT4363 protects the load from destruction by regulating the output voltage to a safe level during intervals of input overvoltage. DC1935A is designed to regulate the output at 16.3V. If the input voltage is less than 16.3V, power passes through directly to the output. The output voltage is sensed by the R1/R2 divider and the FB pin. The GATE pin controls Q1 to regulate the output voltage in the event the input rises above 16.3V.

Overcurrent is sensed by R_{SNS} and the SNS and OUT pins of the LT4363. If the load current reaches 50mV/20m Ω , the GATE pin will control Q1 to regulate the output current at 2.5A.

QUICK START PROCEDURE

In both overcurrent and overvoltage conditions, current is sourced by the TMR pin into the timer capacitor, CTMR. It charges and upon reaching 1.375V, causes the LT4363 to turn off the MOSFET. As previously mentioned the LT4363-1 version latches off, while the LT4363-2 version automatically tries to restart the load after a cool-down interval.

The timer interval before the MOSFET turns off is variable, depending on the type and severity of the fault, and ranges from 150µs to 10ms. The cool-down time is 158ms.

For the LT4363-2 version, automatic retry is inhibited by the OV pin if the input remains higher than 15.5V, as set by the R4-R5-R6 divider. For the LT4363-1 version, the OV pin becomes a ground pin (GND, Pin 7) and it is shorted to ground by a 0Ω jumper at R6. The LT4363-1 version simply latches off in response to a fault. Restart by pulling SHDN low for at least 100µs, or by briefly disconnecting the input supply.

The combined tolerances of the LT4363 and external resistor dividers are approximately 4% for output voltage regulation (FB pin), 5% for undervoltage (UV pin) and retry inhibit threshold (OV pin), and 15% for current limit.

A performance summary is shown in a table on the schematic diagram and is silk-screened on the back of the demo board for easy reference.

BOARD MODIFICATIONS

R1-2 and R4-6 may be changed to customize the UV and OV thresholds, as well as the output regulation voltage. If additional SHDN pin pull-up is desired, R9 may be populated. The board layout is designed for four other modifications.

Modification 1: 28V Operation

As shipped, DC1935A is designed for 12V operation. It may be modified for 28V operation by removing the 0Ω jumpers R1C and R4C. The resulting voltage ranges and thresholds are shown in a table on the schematic diagram and on the silkscreen.

Modification 2: Higher DC Input Capability

Provision is made for buffering the D1 shunt clamp, permitting the use of a much higher value for R7, which in turn reduces its dissipation and allows for longer overvoltage times or higher DC inputs. To modify, remove 0Ω jumper R8, install a PZTA42 for Q2 and increase R7 to 150kΩ. This arrangement can tolerate 250VDC, limited by board spacing considerations, dissipation in R7 (a 1206 resistor can dissipate 250mW), Q3's dissipation (about 750mW at 250V) and Q1's 250V BV_{DSS} rating.

Bear in mind that the circuit board's 2mm spacing is adequate for only 100V long-term continuous bias. Also note that the V_{BE} of Q2 adds to the LT4363's inherent 4V minimum operating voltage, as does the drop in R7.

Modification 3: Higher Current

For higher current applications, DC1935A may be grafted onto a separate assembly comprising a MOSFET, sense resistor and output capacitor (see Figure 1). Through-holes are included to facilitate this modification. Here is the procedure:

1. Remove Q1, R_{SNS} and C_L.
2. Connect short lengths of hook-up wire between DC1935A and the MOSFET assembly. It is imperative that a 10Ω resistor be installed at the MOSFET gate lead to replicate the function of R3.
3. Connect the input supply to the MOSFET drain, and connect the load to the output side of the sense resistor.
4. If parasitic oscillations are observed at start-up, or during voltage or current limiting, add a 100Ω/10nF snubber to the drain of the MOSFET.

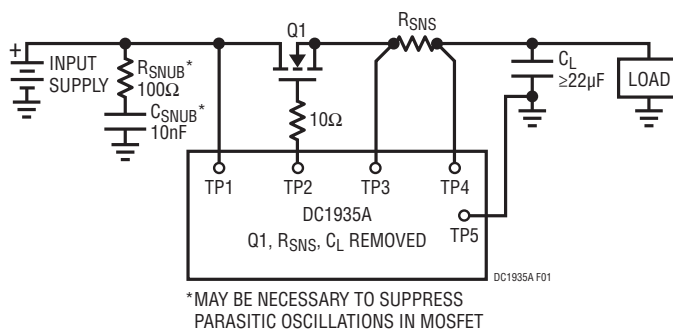

Figure 1. For High Current Applications Assemble Power Path Off-Board and Attach DC1935A Using Through-Hole Test Points

dc1935af

QUICK START PROCEDURE

Modification 4: Higher Operating Voltage

Figure 2 shows a combination of modifications 2 and 3 for high voltage operation. The power path and the V_{CC} pre-regulator are moved off-board to eliminate spacing issues.

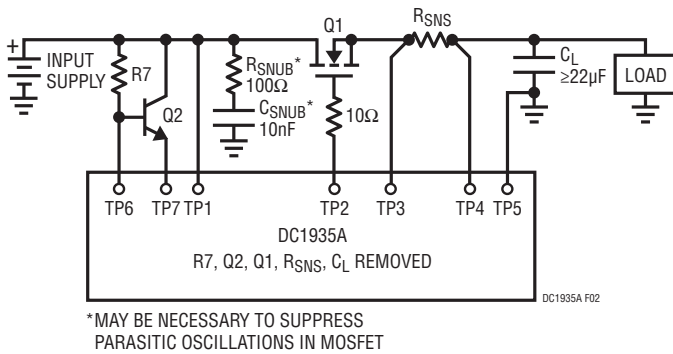

Figure 2. For Higher Input Voltage Operation, Assemble Power Path and V_{CC} Pre-Regulator (Q2 and R7) Off-Board and Attach DC1935A Using Through-Hole Test Points

TEST POINTS

A summary of the test points and their functions is shown in Table 1.

Table 1. Test Point Connections

TEST POINT	EXTERNAL CONNECTION	LT4363 PIN
1	Drain/Input	—
2	Gate	GATE
3	Sense ⁺	SNS
4	Sense ⁻	OUT
5	Ground	GND
6	Base Q2, R7	—
7	Emitter Q2	V_{CC}

SMALL TURRETS

No connection to any of the small turrets is necessary to make the board operate—the LT4363 defaults to the ON state. If the $\overline{\text{SHDN}}$ turret is left open, the board will turn on when power is applied. Short this turret to ground to turn off the LT4363.

$\overline{\text{FLT}}$ and ENOUT are open-collector outputs. If used, pull up to the output or an output-derived external logic supply. There are no pull-ups included on DC1935A. $\overline{\text{FLT}}$ and ENOUT have 100V ratings and can sink 100 μ A to less than 800mV.

TMR is brought out to a turret for the purpose of monitoring the waveform there. It may also be used to connect external timer capacitors.

QUICK START

Connect a 12V supply to input, and connect a load to output as shown in Figure 3. The circuit will turn on automatically when power is applied, and green LED D3 will show that the output is up. LED D4 indicates that input power is present. If the input voltage is increased above 16.3V, the output will shut off and D3 will extinguish. The output will remain off until the input is brought below 15.5V. Similarly, if the input voltage is decreased to less than 5.6V the output will shut off and D3 will extinguish. It will restart when the input rises above 5.7V.

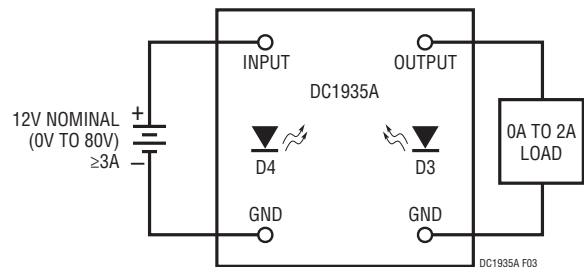

Figure 3. Basic Test Setup

To test the dynamic behavior, apply a transient to the input as shown in Figure 4. Use a storage oscilloscope to monitor both the input and the output, and use the NSG5500 trigger output to trigger the oscilloscope sweep.

QUICK START PROCEDURE

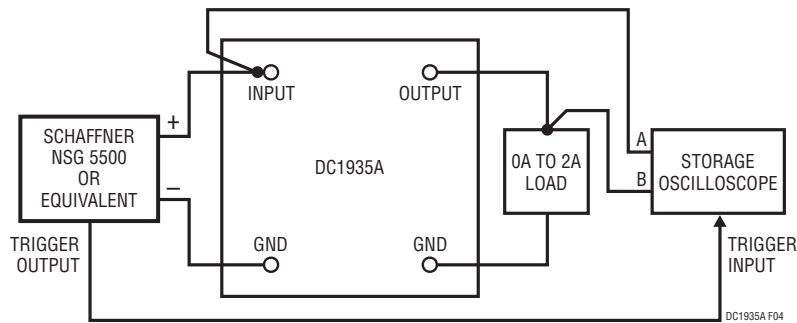

Figure 4. Testing Dynamic Behavior

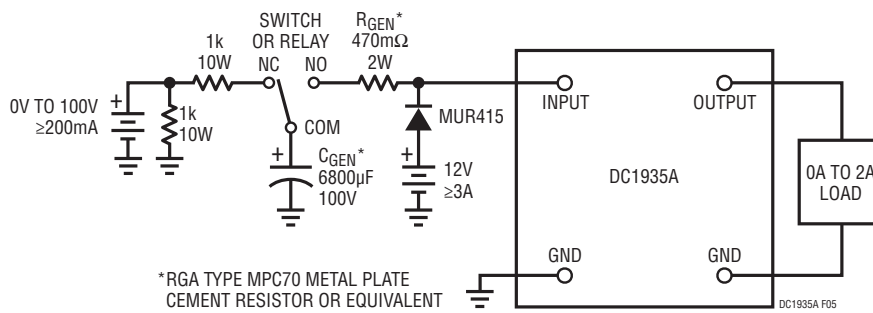

Figure 5. Simple Transient Generator

Another method of developing transients is to discharge a capacitor into the input of DC1935A, as shown in Figure 5. Monitor the behavior with a storage oscilloscope. Allow 30 seconds for complete recharging of the 6800 μ F capacitor. C_{GEN} may be varied to achieve any desired transient duration. Note that when DC1935A turns off, the input waveform will stall since the high current discharge path is disconnected. Either a SPDT switch or a relay can be used to transfer C_{GEN} from the charging supply to DC1935A. A so-called “3-way” light switch is a SPDT configuration and will survive many switching cycles in this circuit.

HIGH VOLTAGE WARNING

DC1935A is designed to handle up to 250V input. When testing the circuit behavior at these levels, beware of lethal voltages produced by transient generators and of charge stored on capacitors such as C_{GEN} in Figure 5. Further, circuit components may explode or ignite as a result of unforeseen operating conditions or component failure. Take all necessary steps to shield and protect personnel and property from these hazards.

Danger! High voltage testing should be performed by qualified personnel only. As a safety precaution at least two people should be present during high voltage testing.

DEMO MANUAL DC1935A

PARTS LIST

ITEM	QTY	REFERENCE	PART DESCRIPTION	MANUFACTURER/PART NUMBER
1	2	CTMR, CG	CAP., X7R, 47nF, 100V 20% 0805	AVX, 08051C473MAT2A
2	1	CL	CAP., ALUM., 33µF 50V 20% SMT	SUN ELECT., 50CE33LX
3	1	CSNUB	CAP., X7R, 10nF, 500V 20% 1206	AVX, 12067C103MAT2A
4	1	C2	CAP., X7R, 100nF, 100V 20% 0805	AVX, 08051C104MAT2A
5	1	C3	CAP., X7R, 10nF, 100V 20% 0805	AVX, 08051C103MAT2A
6	1	D1	DIODE, TVS, 60V, SMA	DIODES/ZETEX, SMAJ60A-13-F
7	1	D2	DIODE, CURRENT LIMITING, SOD-123	CENTRAL SEMI., CMJ2700 TR
8	2	D3, D4	LED, GREEN, SMD	PANASONIC, LN1371SGTRP
9	1	Q1	MOSFET, N-CH, 250V, D2-PAK	FAIRCHILD, FDB33N25TM
10	1	Q3	TRANSISTOR, NPN, 300V, SOT-223	NXP, PZTA42
11	1	Q4	TRANSISTOR, NPN, 40V, SOT-23	DIODES/ZETEX, MMBT3904-7-F
12	1	RG	RES., CHIP, 33Ω, 1/8W, 5% 0805	NIC, NRC10J330TRF
13	1	RSNS	RES., CHIP, SENSE, 0.020Ω, 1/4W, 5% 1206	NIC, NCST12JR020JTRF
14	1	RSNUB	RES., CHIP, 100Ω, 1/2W, 5% 1210 PULSE PROOF	NIC, NRCP25J101TRF
15	1	R1A	RES., CHIP, 118k, 1/8W, 1% 0805	NIC, NRC10F1183TRF
16	1	R1B	RES., CHIP, 143k, 1/8W, 1% 0805	NIC, NRC10F1433TRF
17	1	R1C, R4C, R8	RES., CHIP, 0Ω, 0805	NIC, NRC10Z0TRF
18	1	R2	RES., CHIP, 10k, 1/8W, 1% 0805	NIC, NRC10F1002TRF
19	1	R3	RES., CHIP, 10Ω, 1/8W, 5% 0805	NIC, NRC10J100TRF
20	1	R4A	RES., CHIP, 93.1k, 1/4W, 1% 1206	NIC, NRC12F9312TRF
21	1	R4B	RES., CHIP, 140k, 1/8W, 1% 0805	NIC, NRC10F1403TRF
22	0	R7	RES., CHIP, 1k, 1/4W, 5% 1206 PULSE PROOF	NIC, NRCP12J102TRF
23	1	R10	RES., CHIP, 270k, 1/4W, 5% 1206	NIC, NRC12J274TRF
24	1	R11	RES., CHIP, 240Ω, 1/8W, 5% 0805	NIC, NRC10J241TRF
DC1935A-A				
1	1	R5	RES., CHIP, 28k, 1/8W, 1% 0805	NIC, NRC10F2802TRF
2	1	R6	RES., CHIP, 0Ω, 0805	NIC, NRC10Z0TRF
3	1	U1	I.C., HIGH VOLTAGE SURGE STOPPER	LINEAR TECH., LT4363IDE-1
DC1935A-B				
1	1	R5	RES., CHIP, 18.2k, 1/8W, 1% 0805	NIC, NRC10F1822TRF
2	1	R6	RES., CHIP, 10k, 1/8W, 1% 0805	NIC, NRC10F1002TRF
3	1	U1	I.C., HIGH VOLTAGE SURGE STOPPER	LINEAR TECH., LT4363IDE-2

SCHEMATIC DIAGRAM

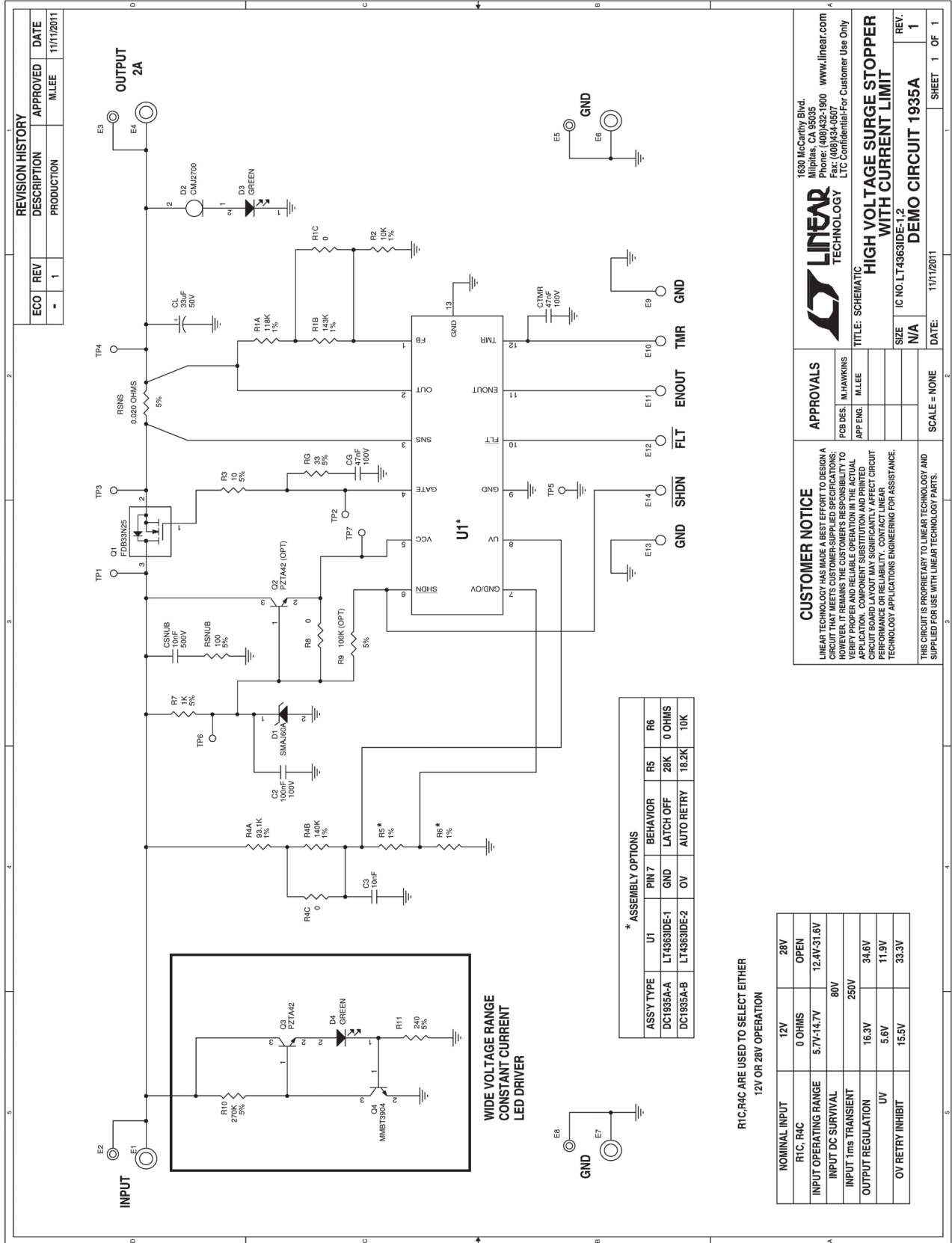

DEMO MANUAL DC1935A

DEMONSTRATION BOARD IMPORTANT NOTICE

Linear Technology Corporation (LTC) provides the enclosed product(s) under the following **AS IS** conditions:

This demonstration board (DEMO BOARD) kit being sold or provided by Linear Technology is intended for use for **ENGINEERING DEVELOPMENT OR EVALUATION PURPOSES ONLY** and is not provided by LTC for commercial use. As such, the DEMO BOARD herein may not be complete in terms of required design-, marketing-, and/or manufacturing-related protective considerations, including but not limited to product safety measures typically found in finished commercial goods. As a prototype, this product does not fall within the scope of the European Union directive on electromagnetic compatibility and therefore may or may not meet the technical requirements of the directive, or other regulations.

If this evaluation kit does not meet the specifications recited in the DEMO BOARD manual the kit may be returned within 30 days from the date of delivery for a full refund. **THE FOREGOING WARRANTY IS THE EXCLUSIVE WARRANTY MADE BY THE SELLER TO BUYER AND IS IN LIEU OF ALL OTHER WARRANTIES, EXPRESSED, IMPLIED, OR STATUTORY, INCLUDING ANY WARRANTY OF MERCHANTABILITY OR FITNESS FOR ANY PARTICULAR PURPOSE. EXCEPT TO THE EXTENT OF THIS INDEMNITY, NEITHER PARTY SHALL BE LIABLE TO THE OTHER FOR ANY INDIRECT, SPECIAL, INCIDENTAL, OR CONSEQUENTIAL DAMAGES.**

The user assumes all responsibility and liability for proper and safe handling of the goods. Further, the user releases LTC from all claims arising from the handling or use of the goods. Due to the open construction of the product, it is the user's responsibility to take any and all appropriate precautions with regard to electrostatic discharge. Also be aware that the products herein may not be regulatory compliant or agency certified (FCC, UL, CE, etc.).

No License is granted under any patent right or other intellectual property whatsoever. **LTC assumes no liability for applications assistance, customer product design, software performance, or infringement of patents or any other intellectual property rights of any kind.**

LTC currently services a variety of customers for products around the world, and therefore this transaction **is not exclusive**.

Please read the DEMO BOARD manual prior to handling the product. Persons handling this product must have electronics training and observe good laboratory practice standards. **Common sense is encouraged.**

This notice contains important safety information about temperatures and voltages. For further safety concerns, please contact a LTC application engineer.

Mailing Address:

Linear Technology
1630 McCarthy Blvd.
Milpitas, CA 95035

Copyright © 2004, Linear Technology Corporation

Компания «Океан Электроники» предлагает заключение долгосрочных отношений при поставках импортных электронных компонентов на взаимовыгодных условиях!

Наши преимущества:

- Поставка оригинальных импортных электронных компонентов напрямую с производств Америки, Европы и Азии, а так же с крупнейших складов мира;
- Широкая линейка поставок активных и пассивных импортных электронных компонентов (более 30 млн. наименований);
- Поставка сложных, дефицитных, либо снятых с производства позиций;
- Оперативные сроки поставки под заказ (от 5 рабочих дней);
- Экспресс доставка в любую точку России;
- Помощь Конструкторского Отдела и консультации квалифицированных инженеров;
- Техническая поддержка проекта, помощь в подборе аналогов, поставка прототипов;
- Поставка электронных компонентов под контролем ВП;
- Система менеджмента качества сертифицирована по Международному стандарту ISO 9001;
- При необходимости вся продукция военного и аэрокосмического назначения проходит испытания и сертификацию в лаборатории (по согласованию с заказчиком);
- Поставка специализированных компонентов военного и аэрокосмического уровня качества (Xilinx, Altera, Analog Devices, Intersil, Interpoint, Microsemi, Actel, Aeroflex, Peregrine, VPT, Syfer, Eurofarad, Texas Instruments, MS Kennedy, Miteq, Cobham, E2V, MA-COM, Hittite, Mini-Circuits, General Dynamics и др.);

Компания «Океан Электроники» является официальным дистрибьютором и эксклюзивным представителем в России одного из крупнейших производителей разъемов военного и аэрокосмического назначения «JONHON», а так же официальным дистрибьютором и эксклюзивным представителем в России производителя высокотехнологичных и надежных решений для передачи СВЧ сигналов «FORSTAR».



JONHON

«JONHON» (основан в 1970 г.)

Разъемы специального, военного и аэрокосмического назначения:

(Применяются в военной, авиационной, аэрокосмической, морской, железнодорожной, горно- и нефтедобывающей отраслях промышленности)

«FORSTAR» (основан в 1998 г.)

ВЧ соединители, коаксиальные кабели, кабельные сборки и микроволновые компоненты:

(Применяются в телекоммуникациях гражданского и специального назначения, в средствах связи, РЛС, а так же военной, авиационной и аэрокосмической отраслях промышленности).



Телефон: 8 (812) 309-75-97 (многоканальный)

Факс: 8 (812) 320-03-32

Электронная почта: ocean@oceanchips.ru

Web: <http://oceanchips.ru/>

Адрес: 198099, г. Санкт-Петербург, ул. Калинина, д. 2, корп. 4, лит. А