

DEMO BOARD MANUAL DC324

LTC1876 High Efficiency, Low Cost, 3-Output Power Supply

DESCRIPTION

Demonstration Board DC324 is a high efficiency, low cost design using the LTC[®]1876. This demo board provides three regulated outputs from a single IC: 3.3V/5A, 5V/5A and 12V/200mA, along with two LDO outputs at 3.3V and 5V. Using only a small number of surface mount components, this design is ideal for network equipment, notebook computers and other portable applications that require low profile, small board area and minimum system cost. High efficiency and low EMI are also achieved by operating the two main power stages 180° out of phase, which, in turn, results in long battery life and smaller input capacitors. All three main outputs can be adjusted externally and the 12V regulator is configured to receive its input from the 3.3V output, the 5V output or an external supply.

DC324 highlights the capabilities of the LTC1876, which incorporates a dual out-of-phase, step-down switching controller and a step-up regulator with an internal 1A, 36V switch. It uses a constant frequency, current mode architecture to provide excellent line and load regulation for all three outputs. The operating frequency of the step-down controller is DC programmable from 150kHz to 300kHz and the frequency of the step-up regulator is fixed at 1.2MHz, allowing the use of tiny, low cost capacitors and inductors. Protection features of the controller include an overvoltage soft latch, an overcurrent latch-off (which can be externally defeated) and internal current foldback for overload situations. At low output currents, two modes of operation are available: Burst Mode[™] operation to maintain high efficiency and burst disable mode to maintain constant frequency operation. The controller is also capable of very low dropout operation, with a 99% maximum duty cycle. To be compatible with battery operation, the input range of this demo board is 7.5V to 24V for the 3.3V and 5V outputs and from 3V to 10V for the 12V output. **Gerber files for this circuit board are available. Call the LTC factory.**

PERFORMANCE SUMMARY (Operating Temperature Range: 0°C to 50°C)

PARAMETERS	CONDITIONS	VALUE	
Input Voltages	Step-Down Channels ($V_{OUT} = 5V$ and $3.3V$); Limited by External MOSFET Drive and Breakdown Requirement	5.2V to 30V	
	Step-Up Channel ($V_{OUT} = 12V$)	2.6V to 11V	
Output Voltages	Step-Down Channel 1; Externally Adjustable	$5.00V \pm 0.10V$	
	Step-Down Channel 2; Externally Adjustable	$3.30V \pm 0.07V$	
	Step-Up Channel; Externally Adjustable	$12.00V \pm 0.24V$	
	5V Linear Regulator	$5.00V \pm 4\%$	
	3.3V Linear Regulator	$3.30V \pm 4\%$	
Load Currents	Step-Down Channels	0 to 5A, 6A Peak	
	Step-Up Channel	$V_{IN2} = 3.3V$	200mA
		$V_{IN2} = 10V$	600mA

PARAMETERS	CONDITIONS	VALUE
Frequencies	Step-Down Channels; Externally Adjustable; FREQSET Pin Tied to INTV _{CC}	300kHz
	Step-Up Channel; Fixed	1.2MHz
Output Ripple Voltages	Step-Down Channel 1; 20MHz BW; V _{IN} = 15V; I _O = 5A	60mV _{P-P}
	Step-Down Channel 2; 20MHz BW; V _{IN} = 15V; I _O = 5A	60mV _{P-P}
	Step-Up Channel; 20MHz BW; V _{IN2} = 5V; I _O = 200mA	50mV _{P-P}
Line Regulation	Step-Down Channel 1; V _{IN} = 7.5V to 24V	±5mV
	Step-Down Channel 2; V _{IN} = 7.5V to 24V	±5mV
	Step-Up Channel; V _{IN} = 3.3V to 10V	±5mV
Load Regulation	Step-Down Channel 1; V _{IN} = 15V; V _{OUT1} = 5.00V; I _O = 0 to 5A	-60mV
	Step-Down Channel 2; V _{IN} = 15V; V _{OUT2} = 3.30V; I _O = 0 to 5A	-60mV
	Step-Up Channel; V _{IN} = 5V; V _{OUT3} = 12.00V; I _O = 0 to 200mA	-10mV
Supply Current	V _{IN} = 15V; All Three Channels On; EXT _{VCC} = V _{OUT1}	80μA*
Shutdown Current	V _{IN} = 15V; STBYMD = 0	20μA
Standby Current	V _{IN} = 15V; 1MΩ Resistor from STBYBD to V _{IN} ; 5V INTV _{CC} and 3.3V LDO On; RUN/SS1 = RUN/SS2 = AUXSD = 0	170μA
Efficiency	V _{IN} = 15V; V _{IN2} = V _{OUT1} ; 4A Load at 5V Channel (Not Including the Supply Current to 12V Channel); 5A Load at 3.3V Channel; 200mA at 12V Channel	90%

*400μA including the supply current from EXT_{VCC}. Dynamic supply current is higher due to the gate charge being delivered at the switching frequency. See the LTC1876 data sheet for more information.

TYPICAL PERFORMANCE CHARACTERISTICS

1; 5V Channel (Both 3.3V and 12V Channels are OFF)

V _{in} (V)	I _{in} (A)	V _{out} (V)	I _{out} (A)	Eff.(%)
15	0.004	5.02	0	0
15	0.01	5.01	0.015	50.1
15	0.023	5	0.052	75.36232
15	0.041	4.99	0.102	82.76098
15	0.182	4.99	0.496	90.66081
15	0.356	4.98	1.004	93.63146
15	0.706	4.98	2.003	94.19207
15	1.066	4.98	3.002	93.49568
15	1.44	4.98	4.002	92.26833
15	1.822	4.97	4.99	90.74387

2; 3.3V Channel (Both 5V and 12V Channels are OFF)

Vin(V)	Iin(A)	Vout(V)	Iout(A)	Eff.(%)
15	0.004	3.38	0	0
15	0.008	3.37	0.014	39.31667
15	0.017	3.356	0.051	67.12
15	0.03	3.346	0.102	75.84267
15	0.131	3.339	0.505	85.81145
15	0.251	3.337	1.004	88.98667
15	0.488	3.335	2.003	91.2569
15	0.735	3.334	3.002	90.78157
15	0.995	3.329	4.001	89.24174
15	1.264	3.32	4.99	87.37764

3; 12V Channel (Both 5V and 3.3V Channels are OFF)

Vin(V)	Iin(mA)	Vout(V)	Iout(mA)	Eff.(%)
5	6	11.96	0	0
5	46	11.97	14	72.86087
5	145	11.95	51	84.06207
5	280	11.94	101	86.13857
5	336	11.94	122	86.70714
5	392	11.94	142	86.50408
5	452	11.94	163	86.11593
5	502	11.94	181	86.1012
5	563	11.94	201	85.25542

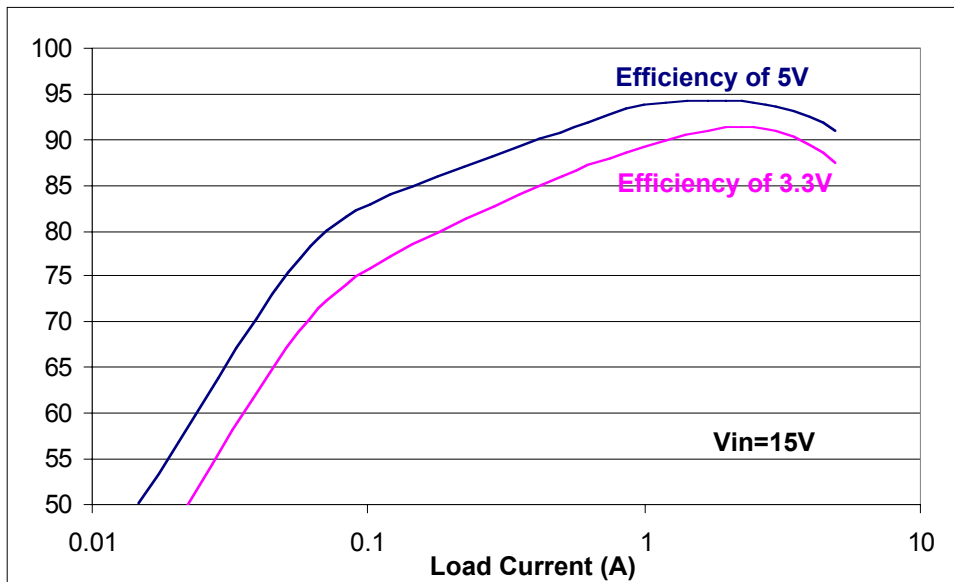

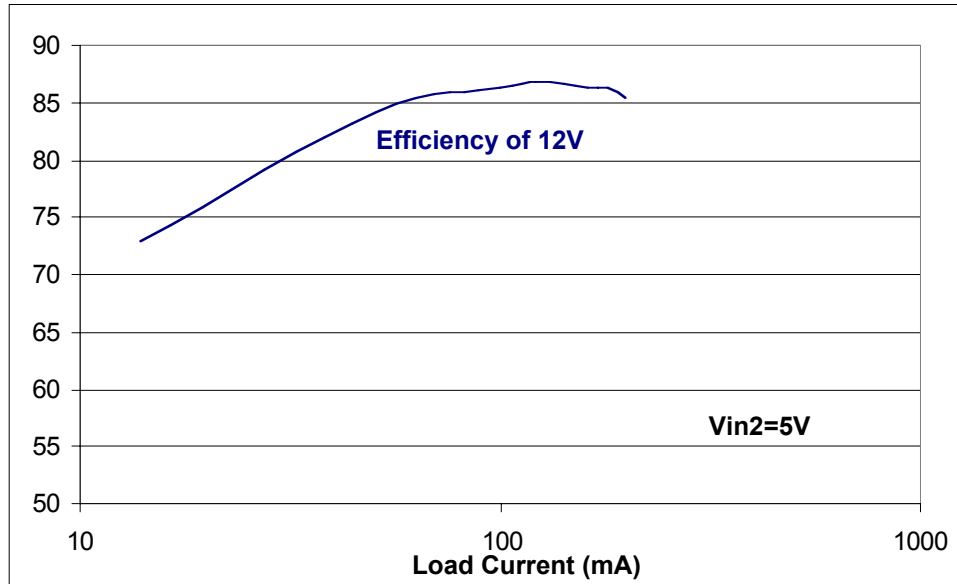

MEASUREMENT SETUP

The circuit shown in Figure 1 provides three fixed voltages: 5V, 3.3V and 12V, at currents of up to 5A, 5A and 200mA, respectively. Figure 2 illustrates the correct measurement setup to be used to verify the typical numbers found in the Performance Summary table. Small spring clip leads are very convenient for small-signal bench testing but should not be used at the current and impedance levels associated with this switching regulator. Soldered wire connections are required to properly ascertain the performance of this demonstration board. Do not tie the grounds together off the test board.

The six jumpers on the left side of the board are settable as follows: the center pin is connected to ground when the jumper is in the rightmost position. The center pin is connected to a positive bias source when the jumper is in the leftmost position. The jumper below L2 at the lower right side of the board is used to select the input supply for the step-up channel. V_{OUT2} (3.3V) is selected if this jumper is in the leftmost position and V_{OUT1} (5V) is selected if it is in the rightmost position. This jumper should be left off when a separate power supply is used through the V_{IN2} terminal near the jumper. Refer to the Jumper Configuration table for jumper functions.

QUICK START GUIDE

This demonstration board is easily set up to evaluate the performance of the LTC1876. Please follow the procedure outlined below for proper operation.

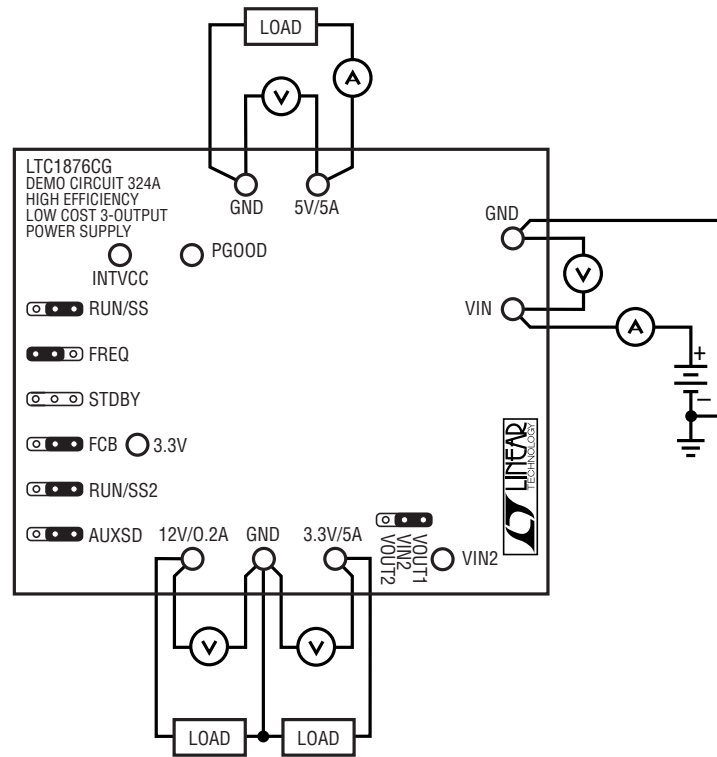

Figure 2. DC324A Test and Measurement Setup

1. Refer to Figure 2 for board orientation and proper measurement equipment setup.
2. Place the jumpers as shown in the diagram. Temporarily leave the STDBY jumper off.
3. Connect the desired loads between V_{OUT1} , V_{OUT2} and V_{OUT3} and their closest GND terminals on the board. The loads can be up to 5A for V_{OUT1} and V_{OUT2} and 200mA for V_{OUT3} . Soldered wires should be used when load current exceeds 1A in order to achieve optimum performance.
4. Connect the input power supply to the V_{IN} and GND terminals on the right edge of the board. Do not increase V_{IN} over 30V or the MOSFETs may be damaged. The recommended V_{IN} to start is $<7V$.

5. Switch on the step-down channel(s) by removing the RUN/SS1 or RUN/SS2 jumpers.
6. Measure V_{OUT1} and V_{OUT2} to verify output voltages of $5.00V \pm 0.10V$ and $3.30V \pm 0.07V$, respectively, at load currents of up to 5A each.
7. Connect the jumper below L2 to select the input supply for the step-up channel. Refer to the Measurement Setup section for proper connection. When V_{OUT1} or V_{OUT2} is selected, reduce the load level of the selected output below 4A or the total load current of the selected channel may exceed 5A.
8. Switch on the step-up channel by placing the AUXSD jumper in the leftmost position.

Active loads can cause confusing results. Refer to the active load discussion in the Operation section.

JUMPER CONFIGURATION

	Left	Right	Open
RUN/SS	Over-Current Latch-Off of Channel 1 Defeated	Channel 1 Shut Off	Over-Current Latch-Off of Channel 1 Enabled
FREQ	300kHz for Channels 1 and 2	150kHz for Channels 1 and 2	230kHz for Channels 1 and 2
STDBY	5V and 3.3V LDOs Turned On	Channels 1 and 2 Shut Off	Channels 1 and 2 Released
FCB	Discontinuous Operation Enabled at Channels 1 and 2	Forced Continuous Operation at Channels 1 and 2	Do Not Leave This Jumper Open
RUN/SS2	Over-Current Latch-Off of Channel 2 Defeated	Channel 2 Shut Off	Over-Current Latch-Off of Channel 2 Enabled
AUXSD	Channel 3 Enabled	Channel 3 Shut Off	Channel 3 Shut Off
V_{IN2}	$V_{IN2} = V_{OUT2}$ Selected	$V_{IN2} = V_{OUT1}$ Selected	A Separate Supply Selected through V_{IN2} Terminal

Item	Qty	Reference	Part Description	Manufacture / Part #
1	6	C1,C4,C7,C16,C21,C29	Capacitor, X7R 0.1uF 10V 20%	AVX 0603ZC104MAT2A
2	2	C2,C20	Capacitor, NPO 27pF 25V 5%	AVX 06033A270JAT1A
3	2	C3,C19	Capacitor, NPO 1000pF 25V 5%	AVX 06033A102JAT1A
4	1	C5	Capacitor, Alum 33uF 35V 10%	OSCON 35CV33BS
5	1	C6	Capacitor, Spcl. Poly. 47uF 6.3V 20%	PANASONIC EEFCD0J470R
6	1	C8	Capacitor, Tant. 4.7uF 10V 20%	AVX TACR475M010R
7	1	C9	Capacitor, NPO 220pF 25V 5%	AVX 06033A221JAT1A
8	1	C10	Capacitor, Spcl. Poly. 56uF 4V 20%	PANASONIC EEFCD0G560R
9	4	C11,C24,C25,C26	Capacitor, Y5V 1uF 10V 80%	AVX 0603ZG105ZAT2A
10	3	C12,C13,C18	Capacitor, X7R .01uF 10V 10%	AVX 0603ZC103KAT1A
11	2	C14,C17	Capacitor, NPO 33pF 50V 10%	AVX 06035A330KAT1A
12	1	C15	Capacitor, NPO 470pF 25V 5%	AVX 06033A471JAT1A
13	1	C22	Capacitor, Tant. 10uF 20V 20%	AVX TPSB106M020
14	1	C23	Capacitor, X7R 2.2uF 25V 20%	AVX 12103C225MAT2A
15	0	C27 (Optional)	Capacitor, X7R 10uF 35V 20%	Taiyo Yuden GMK325BJ106M
16	1	C28	Capacitor, X5R 10uF 25V 20%	Taiyo Yuden TMK432BJ106MN-T
17	2	C30,C31	Capacitor, Y5V 10uF 35V 20%	Taiyo Yuden GMK325F106ZH
18	2	D1,D4	Diode, Rectifier, 40V / 40Amp	Diodes Inc. B140B-13
19	1	D3	Schottky (Comm-Anode)	Zetex BAT54ATA
20	1	D5	Schottky Diode	Central Semi. Corp CMDSH-3
21	6	XJP1-XJP2,XJP4-XJP7	SHUNT, .079" CENTER	COMM-CON CCIJ2MM-138G
22	7	JP1-JP7	Headers, 3 pins	Comm-Conn. 2870MS-03G2
23	2	L2,L1	Inductor, 4.6uH	Sumida CEP123-4R6MC
24	1	L3	Inductor, 10uH	TOKO A920CY-100M
25	2	Q1,Q2	Mosfet N-Chan. Dual	Fairchild FDS6990A
26	2	R1,R13	Resistor, LRC 0.010 0.25W 1%	IRC LRF1206-01-R010-F
27	3	R3,R9,R14	Resistor, Chip 1M 0.06W 5%	AAC CR16-105JM
28	2	R4,R10	Resistor, Chip 20K 0.06W 1%	AAC CR16-2002FM
29	1	R5	Resistor, Chip 105K 0.06W 1%	AAC CR16-1053FM
30	6	R6,R17-R21	Resistor, Chip 10 0.06W 5%	AAC CR16-100JM
31	1	R7	Resistor, Chip 15K 0.06W 5%	AAC CR16-153JM
32	1	R8	Resistor, Chip 6.8K 0.06W 5%	AAC CR16-682JM
33	1	R11	Resistor, Chip 63.4K 0.06W 1%	AAC CR16-6342FM
34	1	R12	Resistor, Chip 10.2K 0.06W 1%	AAC CR16-1022FM

Item	Qty	Reference	Part Description	Manufacture / Part #
35	1	R15	Resistor, Chip 86.6K 0.06W 1%	AAC CR16-8662FM
36	1	R16	Resistor, Chip 100K 0.06W 5%	AAC CR16-104JM
37	11	TP1-TP11	Turret, Testpoint	Mill Max 2501-2
38	1	U1	I.C., LTC1876CG	Linear Tech. Corp. LTC1876CG
39	4		Stand-Off Nylon-Hex 4-40 1/4"	Keystone 1902A
40	4		Screw,#4-40 1/4"	Any
41	1		PRINTED CIRCUIT BOARDS	DEMO BOARD DC324A
42	1		STENCIL	STENCIL DC324A
			Note:please return empty reels.	
			Thanks.	

Компания «Океан Электроники» предлагает заключение долгосрочных отношений при поставках импортных электронных компонентов на взаимовыгодных условиях!

Наши преимущества:

- Поставка оригинальных импортных электронных компонентов напрямую с производств Америки, Европы и Азии, а так же с крупнейших складов мира;
- Широкая линейка поставок активных и пассивных импортных электронных компонентов (более 30 млн. наименований);
- Поставка сложных, дефицитных, либо снятых с производства позиций;
- Оперативные сроки поставки под заказ (от 5 рабочих дней);
- Экспресс доставка в любую точку России;
- Помощь Конструкторского Отдела и консультации квалифицированных инженеров;
- Техническая поддержка проекта, помощь в подборе аналогов, поставка прототипов;
- Поставка электронных компонентов под контролем ВП;
- Система менеджмента качества сертифицирована по Международному стандарту ISO 9001;
- При необходимости вся продукция военного и аэрокосмического назначения проходит испытания и сертификацию в лаборатории (по согласованию с заказчиком);
- Поставка специализированных компонентов военного и аэрокосмического уровня качества (Xilinx, Altera, Analog Devices, Intersil, Interpoint, Microsemi, Actel, Aeroflex, Peregrine, VPT, Syfer, Eurofarad, Texas Instruments, MS Kennedy, Miteq, Cobham, E2V, MA-COM, Hittite, Mini-Circuits, General Dynamics и др.);

Компания «Океан Электроники» является официальным дистрибьютором и эксклюзивным представителем в России одного из крупнейших производителей разъемов военного и аэрокосмического назначения «JONHON», а так же официальным дистрибьютором и эксклюзивным представителем в России производителя высокотехнологичных и надежных решений для передачи СВЧ сигналов «FORSTAR».



JONHON

«JONHON» (основан в 1970 г.)

Разъемы специального, военного и аэрокосмического назначения:

(Применяются в военной, авиационной, аэрокосмической, морской, железнодорожной, горно- и нефтедобывающей отраслях промышленности)

«FORSTAR» (основан в 1998 г.)

ВЧ соединители, коаксиальные кабели, кабельные сборки и микроволновые компоненты:

(Применяются в телекоммуникациях гражданского и специального назначения, в средствах связи, РЛС, а так же военной, авиационной и аэрокосмической отраслях промышленности).



Телефон: 8 (812) 309-75-97 (многоканальный)

Факс: 8 (812) 320-03-32

Электронная почта: ocean@oceanchips.ru

Web: <http://oceanchips.ru/>

Адрес: 198099, г. Санкт-Петербург, ул. Калинина, д. 2, корп. 4, лит. А