



LatticeSC/M Family Data Sheet

DS1004 Version 02.4, December 2011

Features

■ High Performance FPGA Fabric

- 15K to 115K four input Look-up Tables (LUT4s)
- 139 to 942 I/Os
- 700MHz global clock; 1GHz edge clocks

■ 4 to 32 High Speed SERDES and flexiPCS™ (per Device)

- Performance ranging from 600Mbps to 3.8Gbps
- Excellent Rx jitter tolerance (0.8UI at 3.125Gbps)
- Low Tx jitter (0.25UI typical at 3.125Gbps)
- Built-in Pre-emphasis and equalization
- Low power (typically 105mW per channel)
- Embedded Physical Coding Sublayer (PCS) provides pre-engineered implementation for the following standards:
 - GbE, XAUI, PCI Express, SONET, Serial RapidIO, 1G Fibre Channel, 2G Fibre Channel

■ 2Gbps High Performance PURESPEED™ I/O

- Supports the following performance bandwidths
 - Differential I/O up to 2Gbps DDR (1GHz Clock)
 - Single-ended memory interfaces up to 800Mbps
- 144 Tap programmable Input Delay (INDEL) block on every I/O dynamically aligns data to clock for robust performance
 - Dynamic bit Adaptive Input Logic (AIL) monitoring and control circuitry per pin that automatically ensures proper set-up and hold
 - Dynamic bus: uses control bus from DLL
 - Static per bit
- Electrical standards supported:
 - LVCMOS 3.3/2.5/1.8/1.5/1.2, LVTTTL
 - SSTL 3/2/18 I, II; HSTL 18/15 I, II
 - PCI, PCI-X
 - LVDS, Mini-LVDS, Bus-LVDS, MLVDS, LVPECL, RSDS
- Programmable On Die Termination (ODT)
 - Includes Thevenin Equivalent and low power V_{TT} termination options

■ Memory Intensive FPGA

- sysMEM™ embedded Block RAM

- 1 to 7.8 Mbits memory
- True Dual Port/Pseudo Dual Port/Single Port
- Dedicated FIFO logic for all block RAM
- 500MHz performance
- Additional 240K to 1.8Mbits distributed RAM

■ sysCLOCK™ Network

- Eight analog PLLs per device
 - Frequency range from 15MHz to 1GHz
 - Spread spectrum support
- 12 DLLs per device with direct control of I/O delay
 - Frequency range from 100MHz to 700MHz
- Extensive clocking network
 - 700MHz primary and 325 MHz secondary clocks
 - 1GHz I/O-connected edge clocks
- Precision Clock Divider
 - Phase matched x2 and x4 division of incoming clocks
- Dynamic Clock Select (DCS)
 - Glitch free clock MUX

■ Masked Array for Cost Optimization (MACO™) Blocks

- On-chip structured ASIC Blocks provide pre-engineered IP for low power, low cost system level integration

■ High Performance System Bus

- Ties FPGA elements together with a standard bus framework
 - Connects to peripheral user interfaces for run-time dynamic configuration

■ System Level Support

- IEEE standard 1149.1 Boundary Scan, plus ispTRACY™ internal logic analyzer
- IEEE Standard 1532 in-system configuration
- 1.2V and 1.0V operation
- Onboard oscillator for initialization and general use
- Embedded PowerPC microprocessor interface
- Low cost wire-bond and high pin count flip-chip packaging
- Low cost SPI Flash RAM configuration

Table 1-1. LatticeSC Family Selection Guide¹

Device	SC15	SC25	SC40	SC80	SC115
LUT4s (K)	15	25	40	80	115
sysMEM Blocks (18Kb)	56	104	216	308	424
Embedded Memory (Mbits)	1.03	1.92	3.98	5.68	7.8
Max. Distributed Memory (Mbits)	0.24	0.41	0.65	1.28	1.84
Number of 3.8Gbps SERDES (Max.)	8	16	16	32	32
DLLs	12	12	12	12	12
Analog PLLs	8	8	8	8	8
MACO Blocks	4	6	10	10	12
Package I/O/SERDES Combinations (1mm ball pitch)					
256-ball fpBGA (17 x 17mm)	139/4				
900-ball fpBGA (31 x 31mm)	300/8	378/8			
1020-ball fcBGA (33 x 33mm) ²		476/16	562/16		
1152-ball fcBGA (35 x 35mm) ³			604/16	660/16	660/16
1704-ball fcBGA (42.5 x 42.5mm) ³				904/32	942/32

1. The information in this preliminary data sheet is by definition not final and subject to change. Please consult the Lattice web site and your local Lattice sales office to ensure you have the latest information regarding the specifications for these products as you make critical design decisions.
2. Organic fcBGA converted to organic fcBGA revision 2 per [PCN #02A-10](#).
3. Ceramic fcBGA converted to organic fcBGA per [PCN #01A-10](#).

The LatticeSCM devices add MACO-enabled IP functionality to the base LatticeSC devices. Table 1-2 shows the type and number of each pre-engineered IP core.

Table 1-2. LatticeSCM Family

Device	SCM15	SCM25	SCM40	SCM80	SCM115
flexiMAC Blocks <ul style="list-style-type: none"> • 1GbE Mode • 10GbE Mode • PCI Express Mode 	1	2	2	2	4
SPI4.2 Blocks	1	2	2	2	2
Memory Controller Blocks <ul style="list-style-type: none"> • DDR/DDR2 DRAM Mode • QDR II/II+ SRAM Mode • RLDRAM I • RLDRAM II CIO/SIO 	1	2	2	2	2
Low-Speed CDR Blocks	0	0	2	2	2
PCI Express LTSSM (PHY) Blocks	1	0	2	2	2

Note: See each IP core user's guide for more information about support for specific LatticeSCM devices.

Introduction

The LatticeSC family of FPGAs combines a high-performance FPGA fabric, high-speed SERDES, high-performance I/Os and large embedded RAM in a single industry leading architecture. This FPGA family is fabricated in a state of the art technology to provide one of the highest performing FPGAs in the industry.

This family of devices includes features to meet the needs of today's communication network systems. These features include SERDES with embedded advance PCS (Physical Coding sub-layer), up to 7.8 Mbits of sysMEM embedded block RAM, dedicated logic to support system level standards such as RAPIDIO, SPI4.2, SFI-4, UTOPIA, XGMII and CSIX. The devices in this family feature clock multiply, divide and phase shift PLLs, numerous

DLLs and dynamic glitch free clock MUXs which are required in today's high end system designs. High-speed, high-bandwidth I/O make this family ideal for high-throughput systems.

The ispLEVER® design tool from Lattice allows large complex designs to be efficiently implemented using the LatticeSC family of FPGA devices. Synthesis library support for LatticeSC is available for popular logic synthesis tools. The ispLEVER tool uses the synthesis tool output along with the constraints from its floor planning tools to place and route the design in the LatticeSC device. The ispLEVER tool extracts the timing from the routing and back-annotates it into the design for timing verification.

Lattice provides many pre-designed IP (Intellectual Property) ispLeverCORE™ modules for the LatticeSC family. By using these IPs as standardized blocks, designers are free to concentrate on the unique aspects of their design, increasing their productivity.

Innovative high-performance FPGA architecture, high-speed SERDES with PCS support, sysMEM embedded memory and high performance I/O are combined in the LatticeSC to provide excellent performance for today's leading edge systems designs. Table 1-3 details the performance of several common functions implemented within the LatticeSC.

Table1-3. Speed Performance for Typical Functions¹

Functions	Performance (MHz) ²
32-bit Address Decoder	539
64-bit Address Decoder	517
32:1 Multiplexer	779
64-bit Adder (ripple)	353
32x8 Distributed Single Port (SP) RAM	768
64-bit Counter (up or down counter, non-loadable)	369
True Dual-Port 1024x18 bits	372
FIFO Port A: x36 bits, B: x9 bits	375

1. For additional information, see Typical Building BLock Function Performance table in this data sheet.
2. Advance information (-7 speed grade).

Architecture Overview

The LatticeSC architecture contains an array of logic blocks surrounded by Programmable I/O Cells (PIC). Interspersed between the rows of logic blocks are rows of sysMEM Embedded Block RAM (EBR). The upper left and upper right corners of the devices contain SERDES blocks and their associated PCS blocks, as shown in Figure 2-1.

Top left and top right corner of the device contain blocks of SERDES. Each block of SERDES contains four channels (quad). Each channel contains a single serializer and de-serializer, synchronization and word alignment logic. The SERDES quad connects with the Physical Coding Sub-layer (PCS) blocks that contain logic to simultaneously perform alignment, coding, de-coding and other functions. The SERDES quad block has separate supply, ground and reference voltage pins.

The PICs contain logic to facilitate the conditioning of signals to and from the I/O before they leave or enter the FPGA fabric. The block provides DDR and shift register capabilities that act as a gearbox between high speed I/O and the FPGA fabric. The blocks also contain programmable Adaptive Input Logic that adjusts the delay applied to signals as they enter the device to optimize setup and hold times and ensure robust performance.

sysMEM EBRs are large dedicated fast memory blocks. They can be configured as RAM, ROM or FIFO. These blocks have dedicated logic to simplify the implementation of FIFOs.

The PFU, PIC and EBR blocks are arranged in a two-dimensional grid with rows and columns as shown in Figure 2-1. These blocks are connected with many vertical and horizontal routing channel resources. The place and route software tool automatically allocates these routing resources.

The corners contain the sysCLOCK Analog Phase Locked Loop (PLL) and Delay Locked Loop (DLL) Blocks. The PLLs have multiply, divide and phase shifting capability; they are used to manage the phase relationship of the clocks. The LatticeSC architecture provides eight analog PLLs per device and 12 DLLs. The DLLs provide a simple delay capability and can also be used to calibrate other delays within the device.

Every device in the family has a JTAG Port with internal Logic Analyzer (ispTRACY) capability. The sysCONFIG™ port which allows for serial or parallel device configuration. The system bus simplifies the connections of the external microprocessor to the device for tasks such as SERDES and PCS configuration or interface to the general FPGA logic. The LatticeSC devices use 1.2V as their core voltage operation with 1.0V operation also possible.

Figure 2-1. Simplified Block Diagram (Top Level)

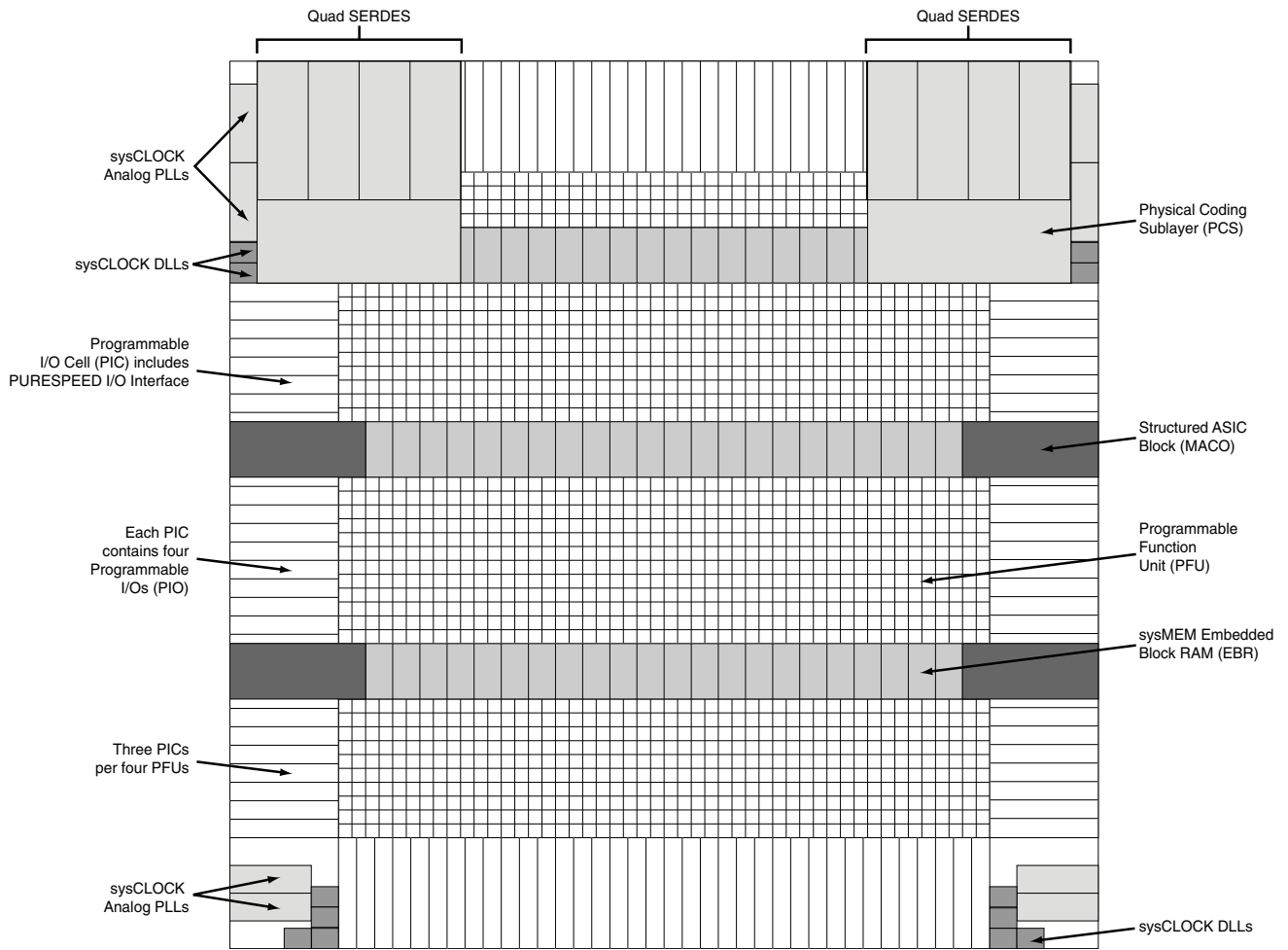

PFU Blocks

The core of the LatticeSC devices consists of PFU blocks. The PFUs can be programmed to perform Logic, Arithmetic, Distributed RAM and Distributed ROM functions.

Each PFU block consists of four interconnected slices, numbered 0-3 as shown in Figure 2-2. All the interconnections to and from PFU blocks are from routing. There are 53 inputs and 25 outputs associated with each PFU block.

Figure 2-2. PFU Diagram

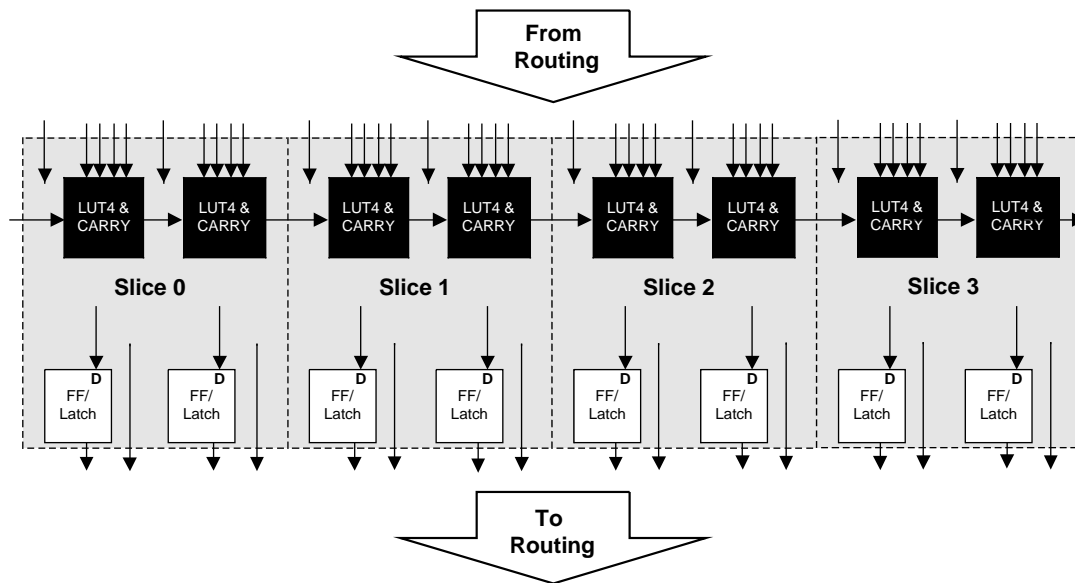

Slice

Each slice contains two LUT4 lookup tables feeding two registers (programmed to be in FF or Latch mode), and some associated logic that allows the LUTs to be combined to implement 5, 6, 7 and 8 Input LUTs (LUT5, LUT6, LUT7 and LUT8). There is control logic to perform set/reset functions (programmable as synchronous/asynchronous), clock select, chip-select and wider RAM/ROM functions. Figure 2-3 shows an overview of the internal logic of the slice. The registers in the slice can be configured for positive/negative and edge/level clocks.

There are 14 input signals: 13 signals from routing and one from the carry-chain (from adjacent slice or PFU). There are seven outputs: six to routing and one to carry-chain (to adjacent PFU). Table 2-1 lists the signals associated with each slice.

Figure 2-3. Slice Diagram

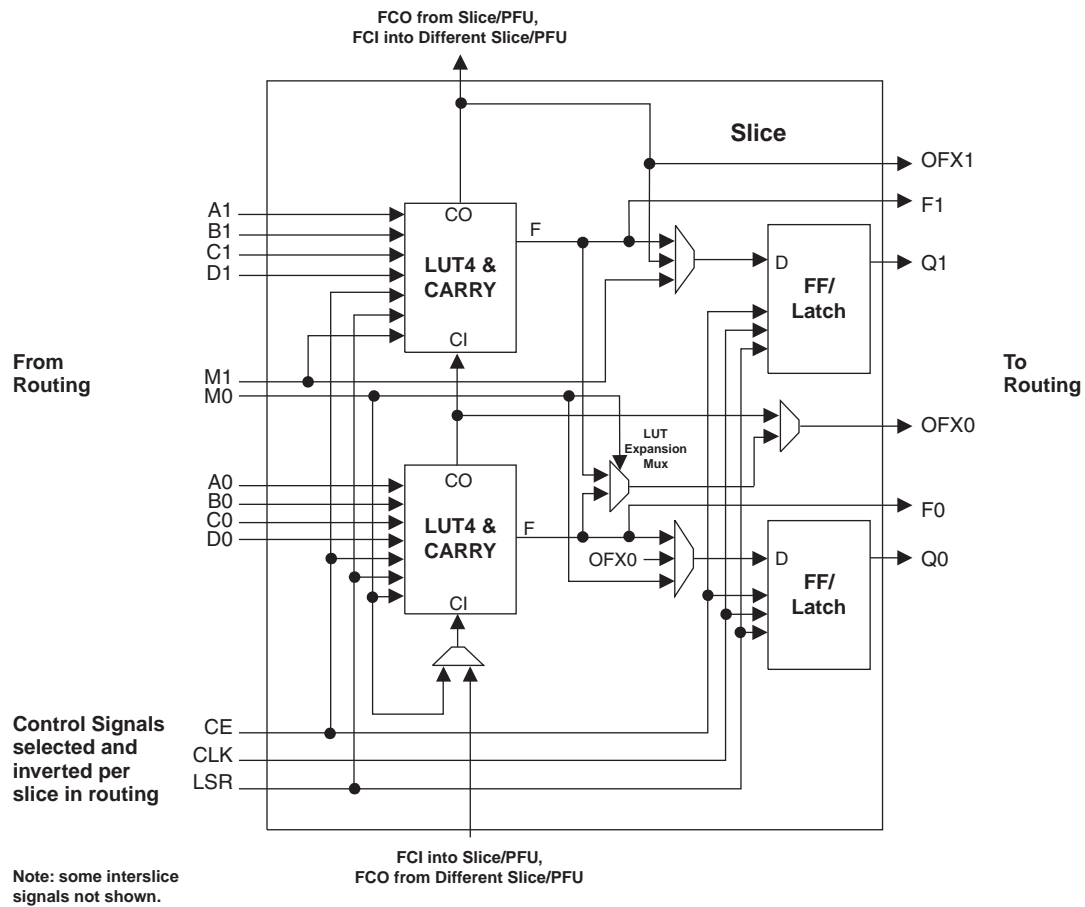

Table 2-1. Slice Signal Descriptions

Function	Type	Signal Names	Description
Input	Data signal	A0, B0, C0, D0	Inputs to LUT4
Input	Data signal	A1, B1, C1, D1	Inputs to LUT4
Input	Multi-purpose	M0	Multipurpose Input
Input	Multi-purpose	M1	Multipurpose Input
Input	Control signal	CE	Clock Enable
Input	Control signal	LSR	Local Set/Reset
Input	Control signal	CLK	System Clock
Input	Inter-PFU signal	FCI	Fast Carry In ¹
Output	Data signals	F0, F1	LUT4 output register bypass signals
Output	Data signals	Q0, Q1	Register Outputs
Output	Data signals	OFX0	Output of a LUT5 MUX
Output	Data signals	OFX1	Output of a LUT6, LUT7, LUT8 ² MUX depending on the slice
Output	Inter-PFU signal	FCO	For the right most PFU the fast carry chain output ²

1. See Figure 2-2 for connection details.

2. Requires two PFUs.

Modes of Operation

Each Slice is capable of four modes of operation: Logic, Ripple, RAM and ROM. Table 2-2 lists the modes and the capability of the Slice blocks.

Table 2-2. Slice Modes

	Logic	Ripple	RAM	ROM
PFU Slice	LUT 4x2 or LUT 5x1	2-bit Arithmetic Unit	SPR 16x2 DPR 16x2	ROM 16x2

Logic Mode

In this mode, the LUTs in each Slice are configured as combinatorial lookup tables. A LUT4 can have 16 possible input combinations. Any logic function with four inputs can be generated by programming this lookup table. Since there are two LUT4s per Slice, a LUT5 can be constructed within one Slice. Larger lookup tables such as LUT6, LUT7 and LUT8 can be constructed by concatenating other Slices in the PFU.

Ripple Mode

Ripple mode allows the efficient implementation of small arithmetic functions. In ripple mode, the following functions can be implemented by each Slice:

- Addition 2-bit
- Subtraction 2-bit
- Up counter 2-bit
- Down counter 2-bit
- Comparator functions of A and B inputs
 - A greater-than-or-equal-to B
 - A not-equal-to B
 - A less-than-or-equal-to B

Ripple Mode includes an optional configuration that performs arithmetic using fast carry chain methods. In this configuration (also referred to as CCU2 mode) two additional signals, Carry Generate and Carry Propagate, are generated on a per slice basis to allow fast arithmetic functions to be constructed by concatenating Slices.

RAM Mode

In this mode, distributed RAM can be constructed using each LUT block as a 16x1-bit memory. Through the combination of LUTs and Slices, a variety of different memories can be constructed.

The Lattice design tools support the creation of a variety of different size memories. Where appropriate, the software will construct these using distributed memory primitives that represent the capabilities of the Slice. Table 2-3 shows the number of Slices required to implement different distributed RAM primitives. Dual port memories involve the pairing of two Slices, one Slice functions as the read-write port. The other companion Slice supports the read-only port. For more information on RAM mode, please see details of additional technical documentation at the end of this data sheet.

Table 2-3. Number of Slices Required For Implementing Distributed RAM

	SPR16x2	DPR16x2
Number of Slices	1	2

Note: SPR = Single Port RAM, DPR = Dual Port RAM

ROM Mode

The ROM mode uses the same principal as the RAM modes, but without the Write port. Pre-loading is accomplished through the programming interface during configuration.

PFU Modes of Operation

Slices can be combined within a PFU to form larger functions. Table 2-4 tabulates these modes and documents the functionality possible at the PFU level.

Table 2-4. PFU Modes of Operation

Logic	Ripple	RAM	ROM
LUT 4x8 or MUX 2x1 x 8	2-bit Add x 4	SPR 16x2 x 4 DPR 16x2 x 2	ROM 16x1 x 8
LUT 5x4 or MUX 4x1 x 4	2-bit Sub x 4	SPR 16x4 x 2 DPR 16x4 x 1	ROM 16x2 x 4
LUT 6x2 or MUX 8x1 x 2	2-bit Counter x 4	SPR 16x8 x 1	ROM 16x4 x 2
LUT 7x1 or MUX 16x1 x 1	2-bit Comp x 4		ROM 16x8 x 1

Routing

There are many resources provided in the LatticeSC devices to route signals individually or as busses with related control signals. The routing resources consist of switching circuitry, buffers and metal interconnect (routing) segments.

The inter-PFU connections are made with x1 (spans two PFU), x2 (spans three PFU) and x6 (spans seven PFU) resources. The x1 and x2 connections provide fast and efficient connections in horizontal, vertical and diagonal directions. All connections are buffered to ensure high-speed operation even with long high-fanout connections.

The ispLEVER design tool takes the output of the synthesis tool and places and routes the design. Generally, the place and route tool is completely automatic, although an interactive routing editor is available to optimize the design.

sysCLOCK Network

The LatticeSC devices have three distinct clock networks for use in distributing high-performance clocks within the device: primary clocks, secondary clocks and edge clocks. In addition to these dedicated clock networks, users are free to route clocks within the device using the general purpose routing. Figure 2-4 shows the clock resources available to each slice.

Figure 2-4. Slice Clock Selection

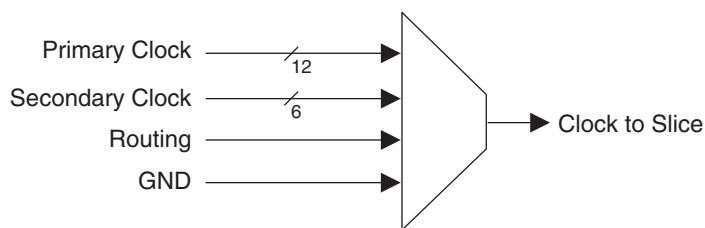

Note: GND is available to switch off the network.

Primary Clock Sources

LatticeSC devices have a wide variety of primary clock sources available. Primary clocks sources consists of the following:

- Primary clock input pins
- Edge clock input pins
- Two outputs per DLL

- Two outputs per PLL
- Clock divider outputs
- Digital Clock Select (DCS) block outputs
- Three outputs per SERDES quad

Figure 2-5 shows the arrangement of the primary clock sources.

Figure 2-5. Clock Sources

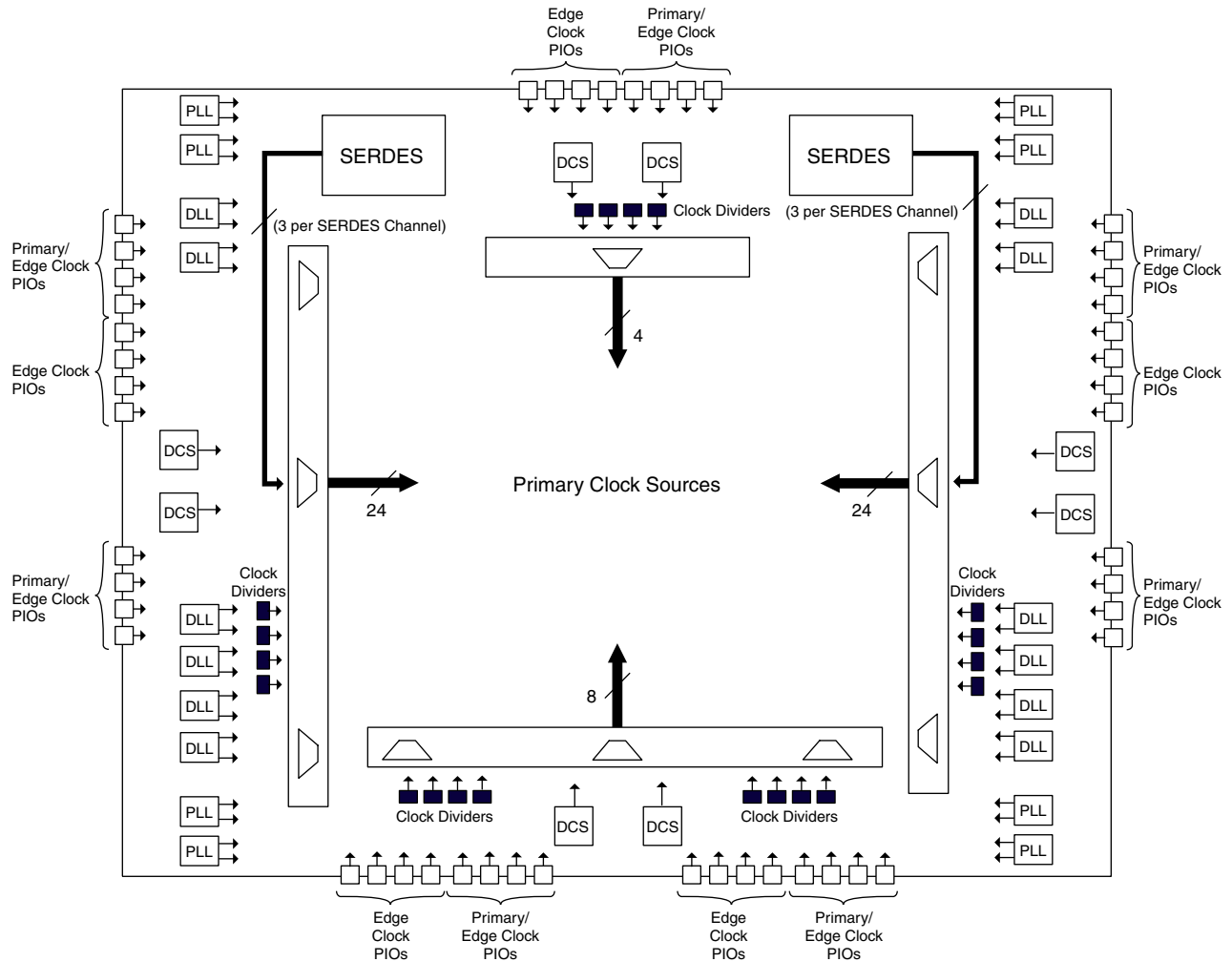

Primary Clock Routing

The clock routing structure in LatticeSC devices consists of 12 Primary Clock lines per quadrant. The primary clocks are generated from 64:1 MUXs located in each quadrant. Three of the inputs to each 64:1 MUX comes from local routing, one is connected to GND and rest of the 60 inputs are from the primary clock sources. Figure 2-6 shows this clock routing.

Figure 2-6. Per Quadrant Clock Selection

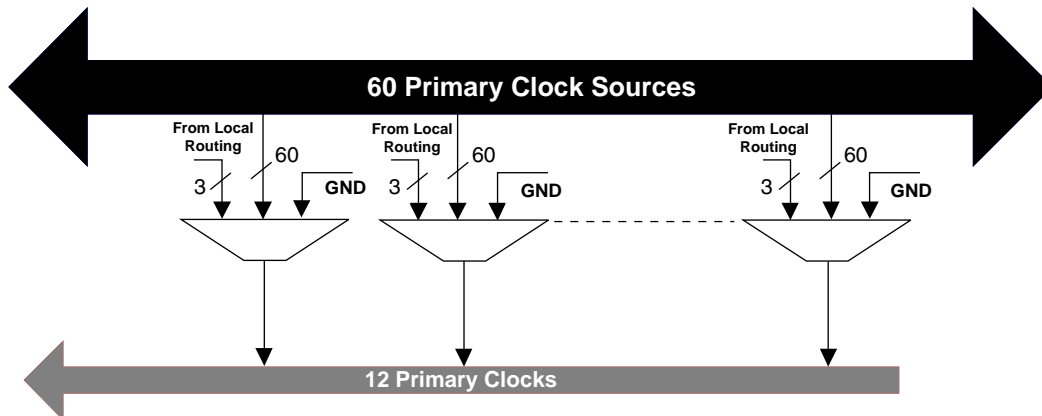

Note: GND is available to switch off the network.

Secondary Clocks

In addition to the primary clock network and edge clocks the LatticeSC devices also contain a secondary clock network. Built of X6 style routing elements this secondary clock network is ideal for routing slower speed clock and control signals throughout the device preserving high-speed clock networks for the most timing critical signals.

Edge Clocks

LatticeSC devices have a number of high-speed edge clocks that are intended for use with the PIOs in the implementation of high-speed interfaces. There are eight edge clocks per bank for the top and bottom of the device. The left and right sides have eight edge clocks per side for both banks located on that side. Figure 2-7 shows the arrangement of edge clocks.

Edge clock resources can be driven from a variety of sources. Edge clock resources can be driven from:

- Edge clock PIOs in the same bank
- Primary clock PIOs in the same bank
- Routing
- Adjacent PLLs and DLLs
- ELSR output from the clock divider

Figure 2-7. Edge Clock Resources

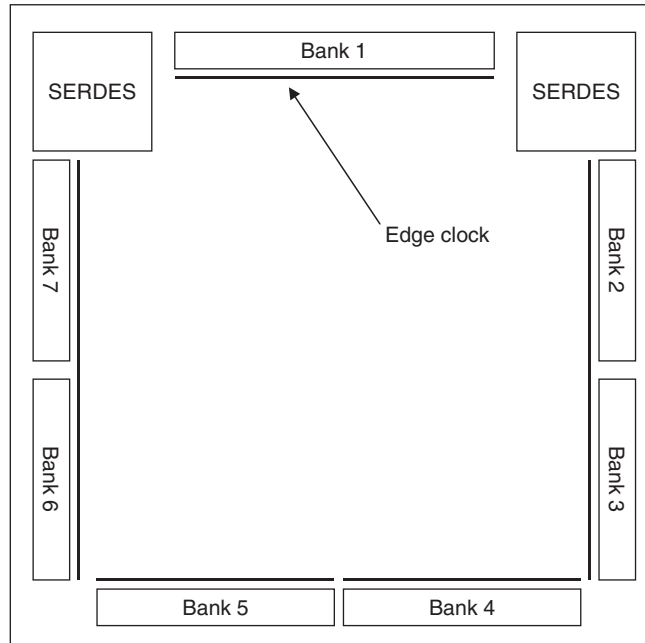

Precision Clock Divider

Each set of edge clocks has four high-speed dividers associated with it. These are intended for generating a slower speed system clock from the high-speed edge clock. The block operates in a DIV2 or DIV4 mode and maintains a known phase relationship between the divided down clock and high-speed clock based on the release of its reset signal. The clock dividers can be fed from selected PIOs, PLLs and routing. The clock divider outputs serve as primary clock sources. This circuit also generates an edge local set/reset (ELSR) signal which is fed to the PIOs via the edge clock network and is used for the rest of the I/O gearing logic.

Figure 2-8. Clock Divider Circuit

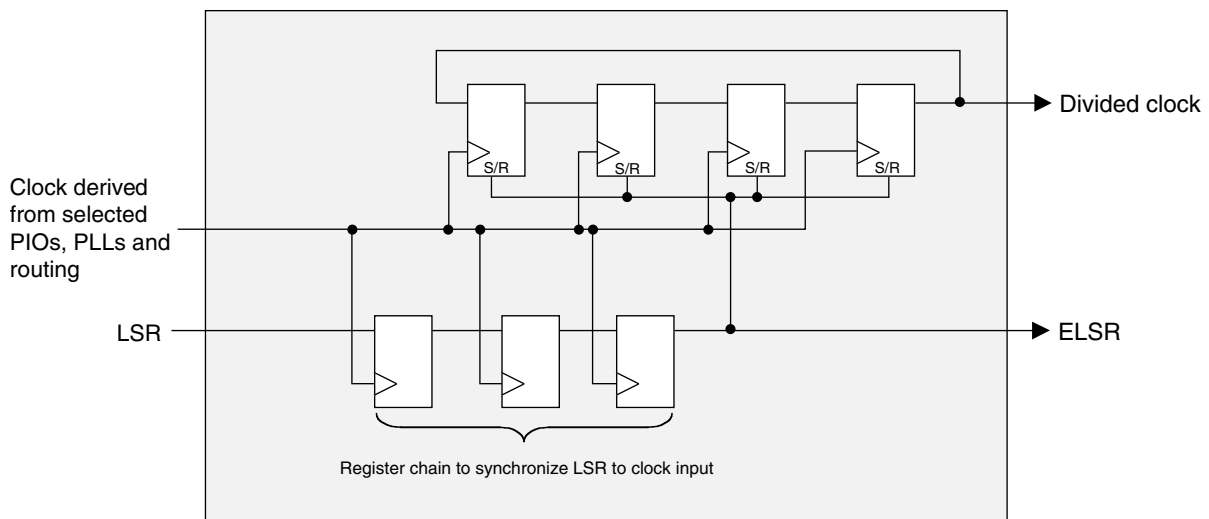

Dynamic Clock Select (DCS)

The DCS is a global clock buffer with smart multiplexer functions. It takes two independent input clock sources and outputs a clock signal without any glitches or runt pulses. This is achieved irrespective of where the select signal is

toggled. There are eight DCS blocks per device, located in pairs at the center of each side. Figure 2-9 illustrates the DCS Block diagram.

Figure 2-9. DCS Block Diagram

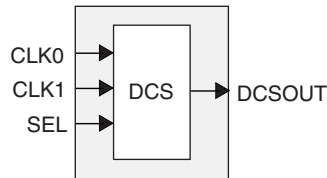
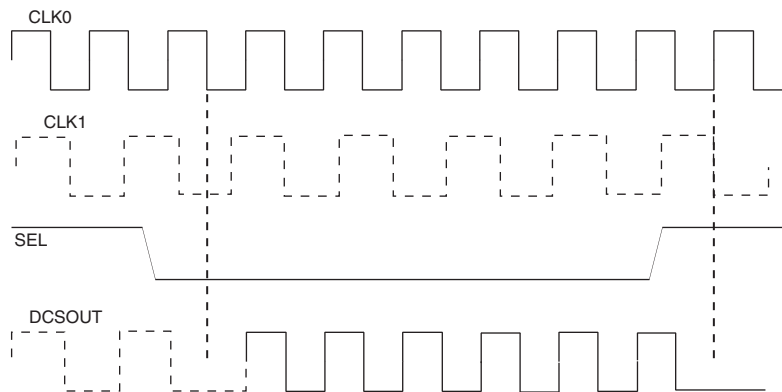

Figure 2-10 shows timing waveforms for one of the DCS operating modes. The DCS block can be programmed to other modes. For more information on the DCS, please see details of additional technical documentation at the end of this data sheet.

Figure 2-10. DCS Waveforms



Clock Boosting

There are programmable delays available in the clock signal paths in the PFU, PIC and EBR blocks. These allow setup and clock-to-output times to be traded to meet critical timing without slowing the system clock. If this feature is enabled then the design tool automatically uses these delays to improve timing performance.

Global Set/Reset

There is a global set/reset (GSR) network on the device that is distributed to all FFs, PLLs, DLLs and other blocks on the device. This GSR network can operate in two modes:

- a) asynchronous - no clock is required to get into or out of the reset state.
- b) synchronous - The global GSR net is synchronized to a user selected clock. In this mode it continues to be asynchronous to get into the reset state, but is synchronous to get out of the reset state. This allows all registers on the device to become operational in the same clock period. The synchronous GSR goes out of reset in two cycles from the clock edge where the setup time of the FF was met (not from the GSR being released).

sysCLOCK Phase Locked Loops (PLLs)

The sysCLOCK PLLs provide the ability to synthesize clock frequencies. Each PLL has four dividers associated with it: input clock divider, feedback divider and two clock output dividers. The input divider is used to divide the input clock signal, while the feedback divider is used to multiply the input clock signal.

The setup and hold times of the device can be improved by programming a delay in the feedback or input path of the PLL which will advance or delay the output clock with reference to the input clock. This delay can be either programmed during configuration or can be adjusted dynamically.

The Phase Select block can modify the phase of the clock signal if desired. The Spread Spectrum block supports the modulation of the PLL output frequency. This reduces the peak energy in the fundamental and its harmonics providing for lower EMI (Electro Magnetic Interference).

The sysCLOCK PLL can be configured at power-up and then, if desired, reconfigured dynamically through the serial memory interface bus which connects with the on-chip system bus. For example, the user can select inputs, loop filters, divider setting, delay settings and phase shift settings. The user can also directly access the SMI bus through the routing.

The PLL clock input, from pin or routing, feeds into an input divider. There are four sources of feedback signal to the feedback divider: from the clock net, directly from the voltage controlled oscillator (VCO) output, from the routing or from an external pin. The signal from the input clock divider and the feedback divider are passed through the programmable delay before entering the phase frequency detector (PFD) unit. The output of this PFD is used to control the voltage controlled oscillator. There is a PLL_LOCK signal to indicate that VCO has locked on to the input clock signal. Figure 2-11 shows the sysCLOCK PLL diagram.

Figure 2-11. PLL Diagram

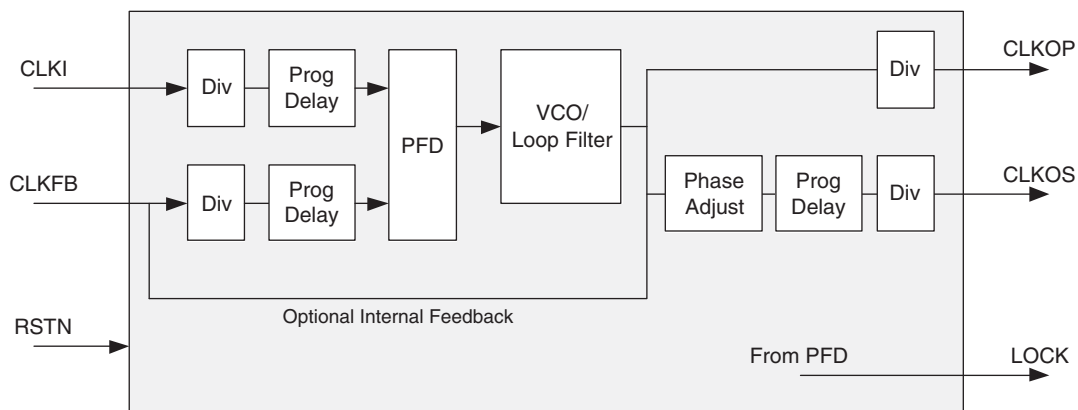

For more information on the PLL, please see details of additional technical documentation at the end of this data sheet.

Spread Spectrum Clocking (SSC)

The PLL supports spread spectrum clocking to reduce peak EMI by using “down-spread” modulation. The spread spectrum operation will vary the output frequency (at 30KHz to 500KHz) in a range that is between its nominal value, down to a frequency that is a programmable 1%, 2%, or 3% lower than normal.

Digital Locked Loop (DLLs)

In addition to PLLs, the LatticeSC devices have up to 12 DLLs per device. DLLs assist in the management of clocks and strobes. DLLs are well suited to applications where the clock may be stopped or transferring jitter from input to output is important, for example forward clocked interfaces. PLLs are good for applications requiring the lowest output jitter or jitter filtering. All DLL outputs are routed as primary/edge clock sources.

The DLL has two independent clock outputs, CLKOP and CLKOS. These outputs can individually select one of the outputs from the tapped delay line. The CLKOS has optional fine phase shift and divider blocks to allow this output to be further modified, if required. The fine phase shift block allows the CLKOS output to phase shifted a further 45, 22.5 or 11.25 degrees relative to its normal position. LOCK output signal is asserted when the DLL is locked. The ALU HOLD signal setting allows users to freeze the DLL at its current delay setting.

There is a Digital Control (DCNTL) bus available from the DLL block. This Digital Control bus is available to the delay lines in the PIC blocks in the adjacent banks. The UDDCNTL signal allows the user to latch the current value on the digital control bus.

Figure 2-12 shows the DLL block diagram of the DLL inputs and outputs. The output of the phase frequency detector controls an arithmetic logic unit (ALU) to add or subtract one delay tap. The digital output of this ALU is used to control the delay value of the delay chain and this digital code is transmitted via the DCNTL bus.

The sysCLOCK DLL can be configured at power-up, then, if desired, reconfigured dynamically through the Serial Memory Interface bus which interfaces with the on-chip Microprocessor Interface (MPI) bus. In addition, users can drive the SMI interface from routing if desired.

The user can configure the DLL for many common functions such as clock injection match and single delay cell. Lattice provides primitives in its design for time reference delay (DDR memory) and clock injection delay removal.

Figure 2-12. DLL Diagram

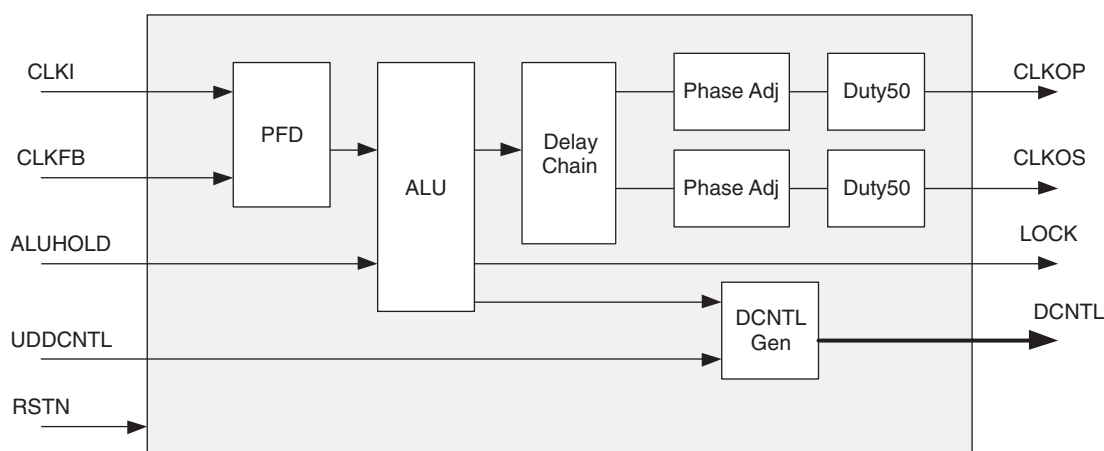

PLL/DLL Cascading

The LatticeSC devices have been designed to allow certain combinations of PLL and DLL cascading. The allowable combinations are as follows:

- PLL to PLL
- PLL to DLL
- DLL to DLL
- DLL to PLL

DLLs are used to shift the clock in relation to the data for source synchronous inputs. PLLs are used for frequency synthesis and clock generation for source synchronous interfaces. Cascading PLL and DLL blocks allows applications to utilize the unique benefits of both DLL and PLLs.

When cascading the DLL to the PLL, the DLL can be used to drive the PLL to create fine phase shifts of an input clock signal. Figure 2-13 shows a shift of all outputs for CLKOP and CLKOS out in time.

Figure 2-13. DLL to PLL

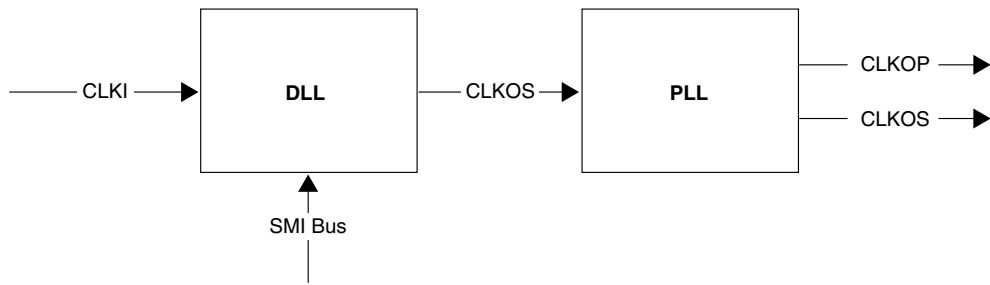

Figure 2-14 shows a shift of only CLKOP out in time.

Figure 2-14. PLL to DLL

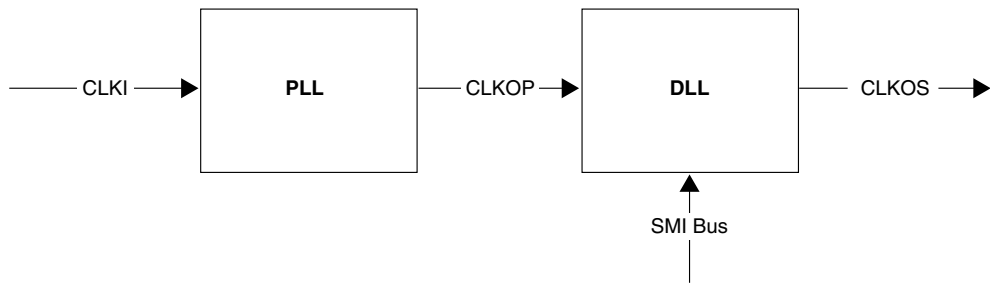
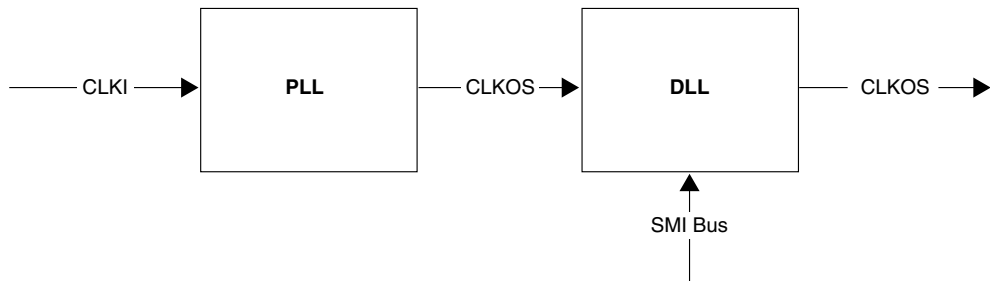

Figure 2-15 shows a shift of only CLKOS out in time.

Figure 2-15. PLL to DLL



For further information on the DLL, please see details of additional technical documentation at the end of this data sheet.

sysMEM Memory Block

The sysMEM block can implement single port, true dual port, pseudo dual port or FIFO memories. Dedicated FIFO support logic allows the LatticeSC devices to efficiently implement FIFOs without consuming LUTs or routing resources for flag generation. Each block can be used in a variety of depths and widths as shown in Table 2-5. Memory with ranges from x1 to x18 in all modes: single port, pseudo-dual port and FIFO also providing x36.

Table 2-5. sysMEM Block Configurations

Memory Mode	Configurations
Single Port	16,384 x 1 8,192 x 2 4,096 x 4 2,048 x 9 1,024 x 18 512 x 36
True Dual Port	16,384 x 1 8,192 x 2 4,096 x 4 2,048 x 9 1,024 x 18
Pseudo Dual Port	16,384 x 1 8,192 x 2 4,096 x 4 2,048 x 9 1,024 x 18 512 x 36
FIFO	16,384 x 1 8,192 x 2 4,096 x 4 2,048 x 9 1,024 x 18 512 x 36

Bus Size Matching

All of the multi-port memory modes support different widths on each of the ports. The RAM bits are mapped LSB word 0 to MSB word 0, LSB word 1 to MSB word 1 and so on. Although the word size and number of words for each port varies, this mapping scheme applies to each port.

RAM Initialization and ROM Operation

If desired, the contents of the RAM can be pre-loaded during device configuration. By preloading the RAM block during the chip configuration cycle and disabling the write controls, the sysMEM block can also be utilized as a ROM.

Single, Dual and Pseudo-Dual Port Modes

In all the sysMEM RAM modes the input data and address for the ports are registered at the input of the memory array. The output data of the memory is optionally registered at the output. A clock is required even in asynchronous read mode.

The EBR memory supports two forms of write behavior for dual port operation:

1. **Normal** — data on the output appears only during a read cycle. During a write cycle, the data (at the current address) does not appear on the output.
2. **Write Through** — a copy of the input data appears at the output of the same port.

FIFO Configuration

The FIFO has a write port with Data-in, WCE, WE and WCLK signals. There is a separate read port with Data-out, RCE, RE and RCLK signals. The FIFO internally generates Almost Full, Full, Almost Empty, and Empty Flags. The Full and Almost Full flags are registered with WCLK. The Empty and Almost Empty flags are registered with RCLK.

EBR Asynchronous Reset

EBR asynchronous reset or GSR (if used) can only be applied if all clock enables are low for a clock cycle before the reset is applied and released a clock cycle after the low-to-high transition of the reset, as shown in Figure 2-16.

Figure 2-16. EBR Asynchronous Reset (Including GSR) Timing Diagram

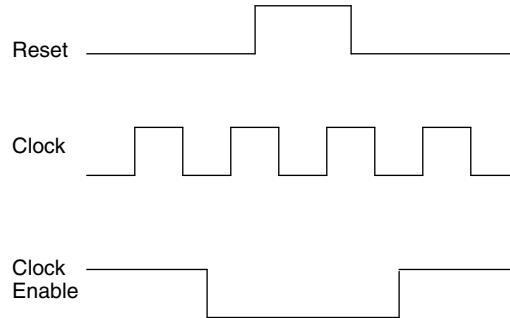

If all clock enables remain enabled, the EBR asynchronous reset or GSR may only be applied and released after the EBR read and write clock inputs are in a steady state condition for a minimum of $1/f_{MAX}$ (EBR clock). The reset release must adhere to the EBR synchronous reset setup time before the next active read or write clock edge.

If an EBR is pre-loaded during configuration, the GSR input must be disabled or the release of the GSR during device Wake Up must occur before the release of the device I/Os becoming active.

These instructions apply to all EBR RAM, ROM, FIFO and shift register implementations. For the EBR FIFO mode, the GSR signal is always enabled and the WE and RE signals act like the clock enable signals in Figure 2-16. The reset timing rules apply to the RPRreset input vs. the RE input and the RST input vs. the WE and RE inputs. Both RST and RPRreset are always asynchronous EBR inputs. For the EBR shift register mode, the GSR signal is always enabled and the local RESET pin is always asynchronous.

Note that there are no reset restrictions if the EBR synchronous reset is used and the EBR GSR input is disabled. For more information about on-chip memory, see TN1094, [On-Chip Memory Usage Guide for LatticeSC Devices](#).

Programmable I/O Cells (PIC)

Each PIC contains four PIOs connected to their respective PURESPEED I/O Buffer which are then connected to the PADs as shown in Figure 2-17. The PIO Block supplies the output data (DO) and the Tri-state control signal (TO) to PURESPEED I/O buffer, and receives input (DI) from the buffer. The PIO contains advanced capabilities to allow the support of speeds up to 2Gbps. These include dedicated shift and DDR logic and adaptive input logic. The dedicated resources simplify the design of robust interfaces.

Figure 2-17. PIC Diagram

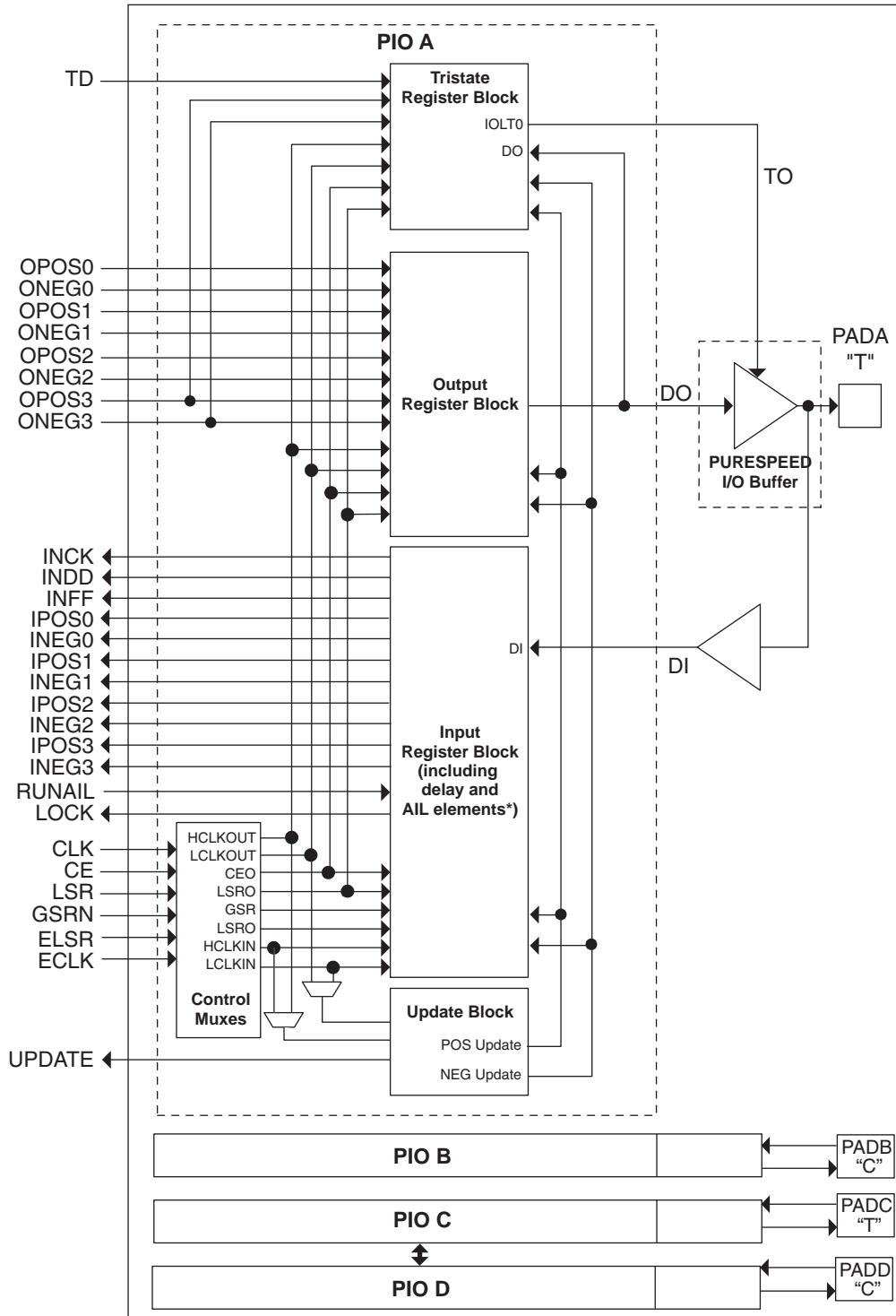

*AIL only on A or C pads located on the left, right and bottom of the device.

The A/B PIOs on the left and the right of the device can be paired to form a differentiated driver. The A/B and C/D PIOs on all sides of the device can be paired to form differential receivers. Either A or C PIOs on all sides except the one on top also provide a connection to an adaptive input logic capability that facilitates the implementation of

high-speed interfaces in the LatticeSC devices. Figure 2-18 shows how differential receivers and drivers are arranged between PIOs.

Figure 2-18. Differential Drivers and Receivers

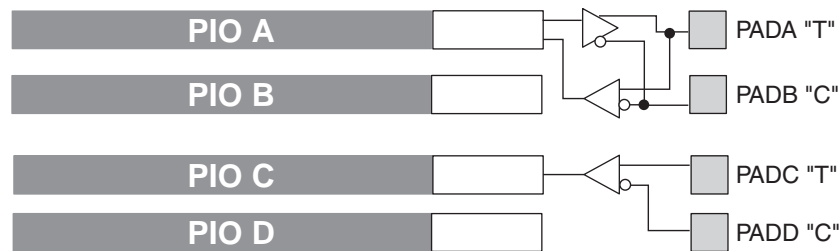

*Differential Driver only available on right and left of the device.

PIO

The PIO contains five blocks: an input register block, output register block, tristate register block, update block, and a control logic block. These blocks contain registers for both single data rate (SDR), double data rate (DDR), and shift register operation along with the necessary clock and selection logic.

Input Register Block

The input register block contains delay elements and registers that can be used to condition signals before they are passed to the device core. Figure 2-20 show the diagram of the input register block. The signal from the PURE-SPEED I/O buffer (DI) enters the input register block and can be used for three purposes, as a source for the combinatorial (INDD) and clock outputs (INCK), the input into the SDR register/latch block and the input to the delay block. The output of the delay block can be used as combinatorial (INDD) and clock (INCK) outputs, an input to the DDR/Shift Register Block or an input into the SDR register block.

Input SDR Register/Latch Block

The SDR register/latch block has a latch and a register/latch that can be used in a variety of combinations to provide a registered or latched output (INFF). The latch operates off high-speed input clocks and latches data on the positive going edge. The register/latch operates off the low-speed input clock and registers/latches data on the positive going edge. Both the latch and the register/latch have a clock enable input that is driven by the input clock enable. In addition both have a variety of programmable options for set/reset including, set or reset, asynchronous or synchronous Local Set Reset LSR (LSR has precedence over CE) and Global Set Reset GSR enable or disable. The register and latch LSR inputs are driven from LSRI, which is generated from the PIO control MUX. The GSR inputs are driven from the GSR output of the PIO control MUX, which allows the global set-reset to be disabled on a PIO basis.

Input Delay Block

The delay block uses 144 tapped delay lines to obtain coarse and fine delay resolution. These delays can be adjusted during configuration or automatically via DLL or AIL blocks. The Adaptive Input Logic (AIL) uses this delay block to adjust automatically the delay in the data path to ensure that it has sufficient setup and hold time.

The delay line in this block matches the delay line that is used in the 12 on-chip DLLs. The delay line can be set via configuration bits or driven from a calibration bus that allows the setting to be controlled either from one of the on-chip DLLs or user logic. Controlling the delay from one of the on-chip DLLs allow the delay to be calibrated to the DLL clock and hence compensated for the variations in process, voltage and temperature.

Adaptive Input Logic (AIL) Overview

The Adaptive Input Logic (AIL) provides the ability of the input logic to dynamically find a solution by monitoring multiple samples of the input data. The input data signal from the input buffer is run through a delay chain. Data, transitions, jitter, noise are all contained inside of the delay chain. The AIL will then search the delay chain for a clean sampling point for data. Once found the AIL will monitor and walk with the data dynamically. This novel approach of using a delay chain to create multiple copies of the data provides a lower power solution than oversampling data with a higher speed clock. Figure 2-19 provides a high level view of the AIL methodology.

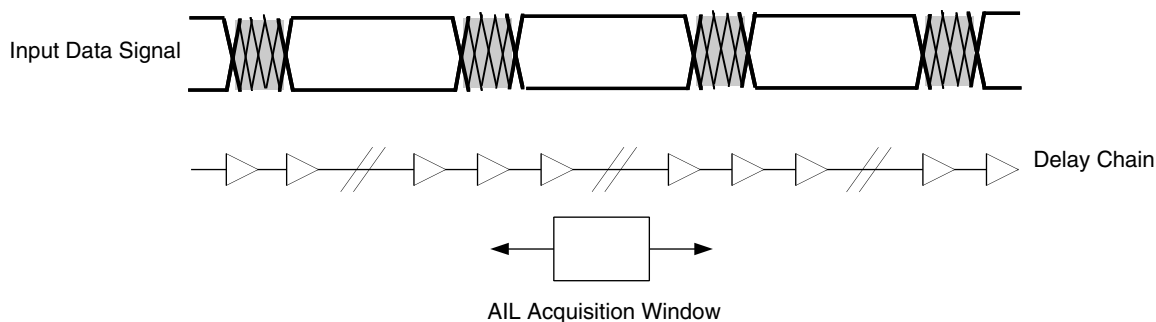
Figure 2-19. LatticeSC AIL Delay of Input Data Waveform

The AIL slides the acquisition window through the delay chain searching for stable data based solely on data transitions. A specific training pattern is not required to perform this bit alignment, simply data transitions. The size of the acquisition window is user-selectable allowing the AIL to operate over the full range of the PURESPEED I/O range. Based on dynamic user control the AIL can either continuously adjust the window location based on data edge detection or it can be locked to a specific delay.

The AIL operates on single data and double data rate interfaces and is available on most FPGA input pins on the LatticeSC device and all buffer types. The AIL block is low power using only 0.003 mW/MHz typical (6 mW @ 2 Gbps) for PRBS 2^7 data. Multiple AIL inputs can be used to create a bus with a FPGA circuit to realign the bus to a common clock cycle. The FPGA circuit to realign the bus is required and is provided by Lattice as a reference design.

For more information on the LatticeSC AIL please refer to TN1158 [LatticeSC PURESPEED I/O Adaptive Input Logic User's Guide](#).

Input DDR/Shift Block

The DDR/Shift block contains registers and associated logic that support DDR and shift register functions using the high-speed clock and the associated transfer to the low-speed clock domain. It functions as a gearbox allowing high-speed incoming data to be passed into the FPGA fabric. Each PIO supports DDR and x2 shift functions. If desired PIOs A and B or C and D can be combined to form x4 shift functions. The PIOs A and C on the left, right and bottom of the device also contain an optional Adaptive Input Logic (AIL) element. This logic automatically aligns incoming data with the clock allowing for easy design of high-speed interfaces. Figure 2-21 shows a simplified block diagram of the shift register block. The shift block in conjunction with the update and clock divider blocks automatically handles the hand off between the low-speed and high-speed clock domains.

Figure 2-20. Input Register Block¹

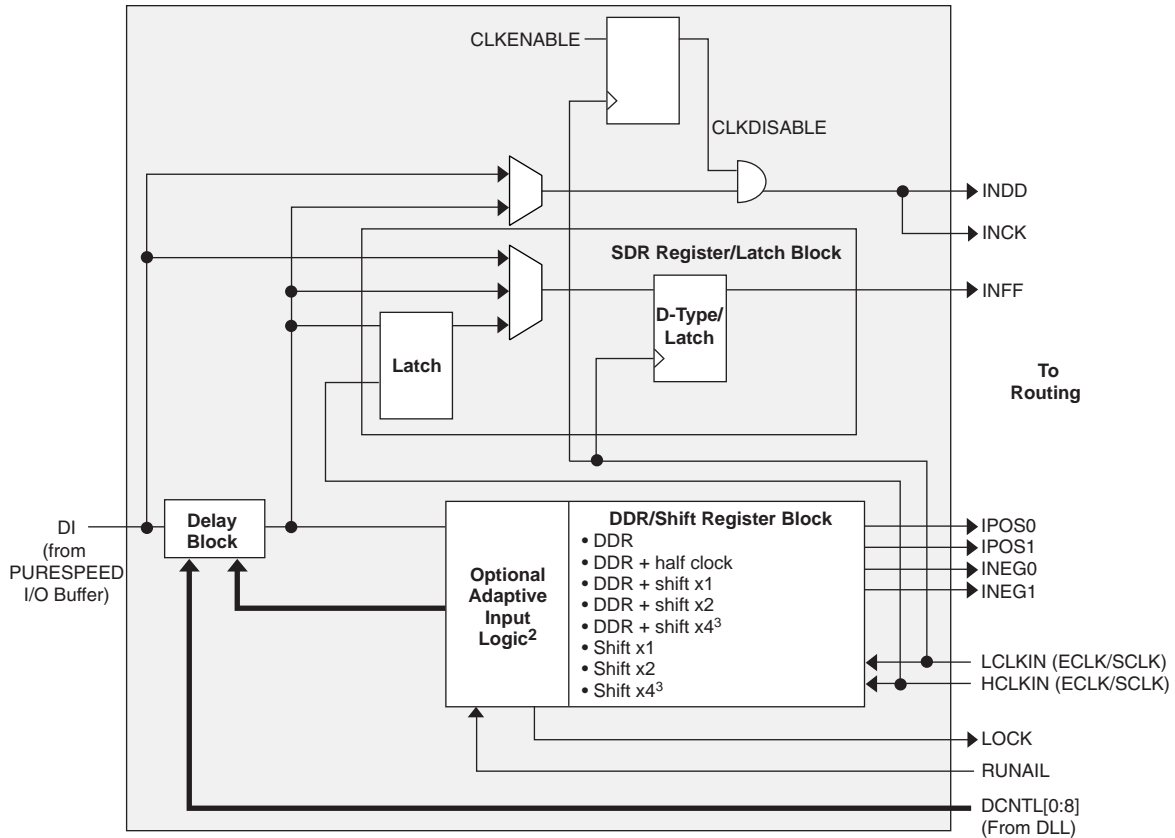

1. UPDATE, Set and Reset not shown for clarity
2. Adaptive input logic is only available in selected PIO
3. By four shift modes utilize DDR/shift register block from paired PIO.
4. CLKDISABLE is used to block the transitions on the DQS pin during post-amble. Its main use is to disable DQS (typically found in DDR memory interfaces) or other clock signals. It can also be used to disable any/all input signals to save power.

Figure 2-21. Input DDR/Shift Register Block

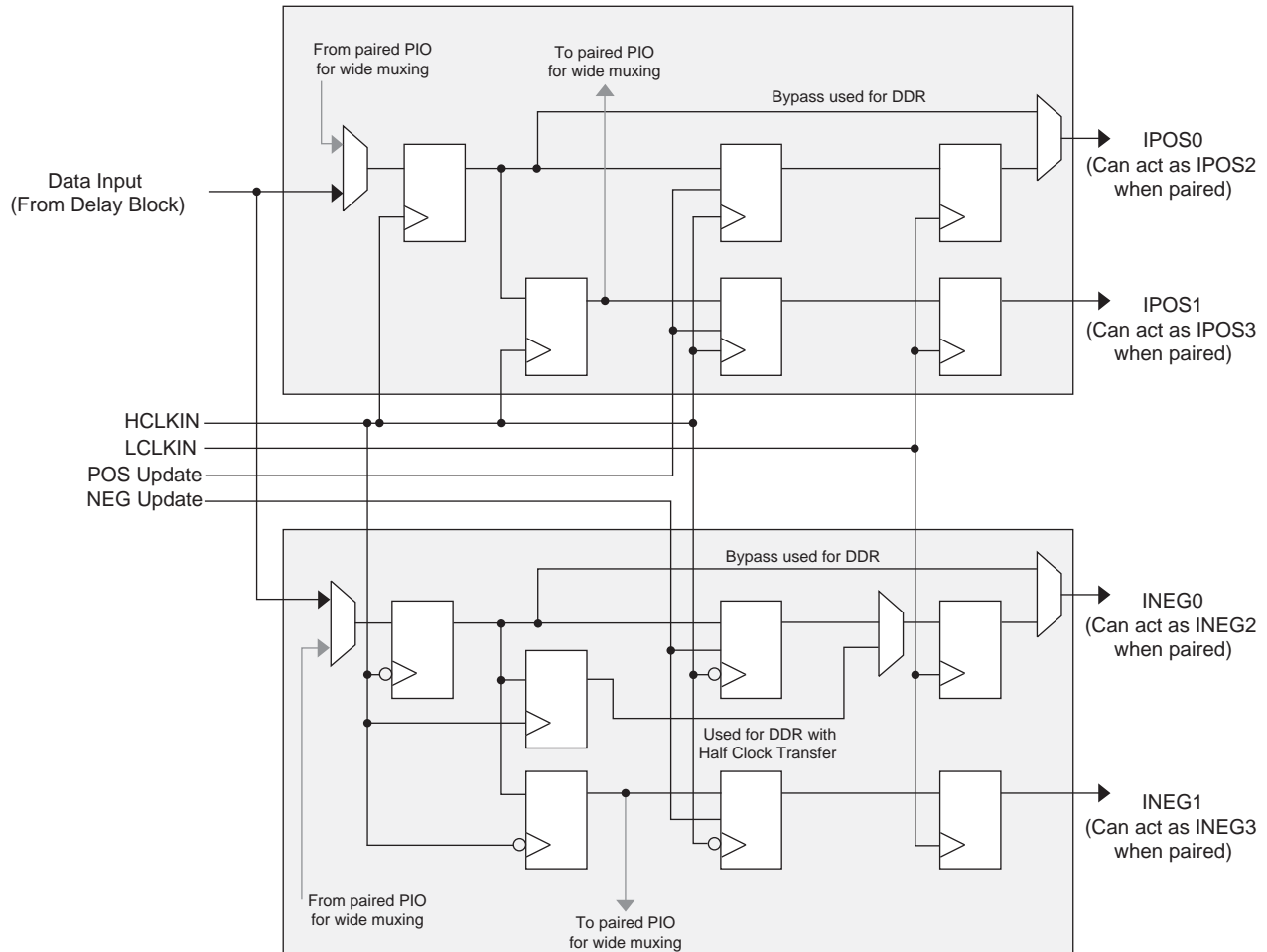

Output Register Block

The output register block provides the ability to register signals from the core of the device before they are passed to the PURESPEED I/O buffers. The block contains a register for SDR operation and a group of registers for DDR and shift register operation. The output signal (DO) can be derived directly from one of the inputs (bypass mode), the SDR register or the DDR/shift register block. Figure 2-22 shows the diagram of the Output Register Block.

Output SDR Register/Latch Block

The SDR register operates on the positive edge of the high-speed clock. It has clock enable that is driven by the clock enable output signal generated by the control MUX. In addition it has a variety of programmable options for set/reset including, set or reset, asynchronous or synchronous Local Set Reset LSR (LSR has precedence over CE) and Global Set Reset GSR enable or disable. The register LSR input is driven from LSRO, which is generated from the PIO control MUX. The GSR inputs is driven from the GSR output of the PIO control MUX, which allows the global set-reset to be disabled on a PIO basis.

Output DDR/Shift Block

The DDR/Shift block contains registers and associated logic that support DDR and shift register functions using the high-speed clock and the associated transfer from the low-speed clock domain. It functions as a gearbox allowing low-speed parallel data from the FPGA fabric be output as a higher speed serial stream. Each PIO supports DDR and x2 shift functions. If desired PIOs A and B or C and D can be combined to form x4 shift functions. Figure 2-22 shows a simplified block diagram of the shift register block.

Figure 2-22. Output Register Block¹

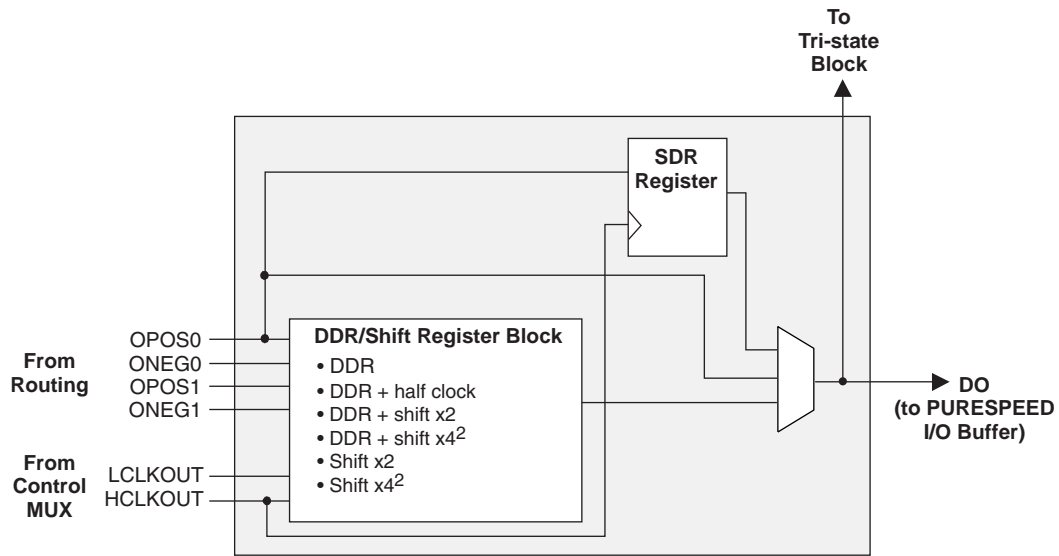

- Notes:
1. CE, Update, Set and Reset not shown for clarity.
 2. By four shift modes utilizes DDR/Shift register block from paired PIO.
 3. DDR/Shift register block shared with tristate block.

Figure 2-23. Output/Tristate DDR/Shift Register Block

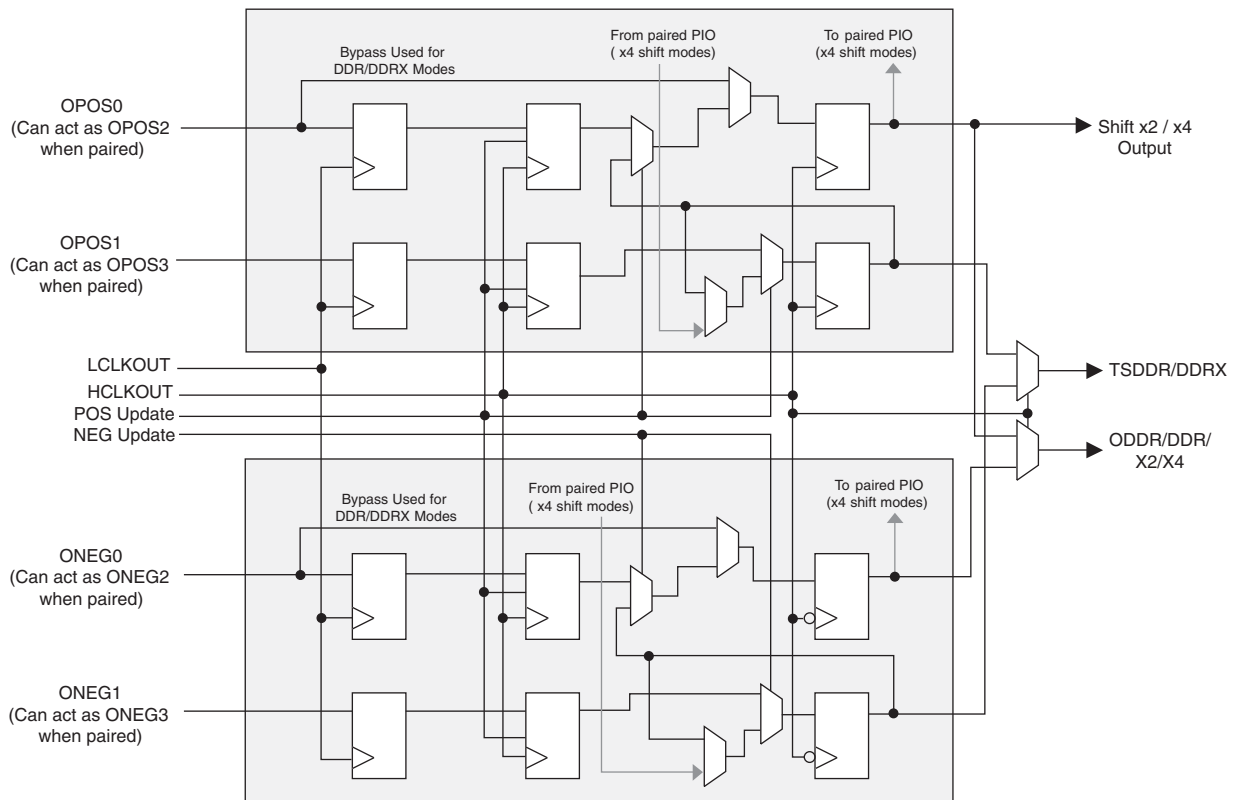

Tristate Register Block

The tristate register block provides the ability to register tri-state control signals from the core of the device before they are passed to the PURESPEED I/O buffers. The block contains a register for SDR operation and a group of three registers for DDR and shift register operation. The output signal tri-state control signal (TO) can be derived directly from one of the inputs (bypass mode), the SDR shift register, the DDR registers or the data associated with the buffer (for open drain emulation). Figure 2-24 shows the diagram of the Tristate Register Block.

Tristate SDR Register/Latch Block

The SDR register operates on the positive edge of the high-speed clock. In it has a variety of programmable options for set/reset including, set or reset, asynchronous or synchronous Local Set Reset LSR and Global Set Reset GSR enable or disable. The register LSR input is driven from LSRO, which is generated from the PIO control MUX. The GSR input is driven from the GSR output of the PIO control MUX, which allows the global set-reset to be disabled on a PIO basis.

Tristate DDR/Shift Register Block

The DDR/Shift block is shared with the output block allowing DDR support using the high-speed clock and the associated transfer from the low-speed clock domain. It functions as a gearbox allowing low-speed parallel data from the FPGA fabric to provide a high-speed tri-state control stream.

There is a special mode for DDR-II memory interfaces where the termination is controlled by the output tristate signal. During WRITE cycle when the FPGA is driving the lines, the parallel terminations are turned off. During READ cycle when the FPGA is receiving data, the parallel terminations are turned on.

Figure 2-24. Tristate Register Block¹

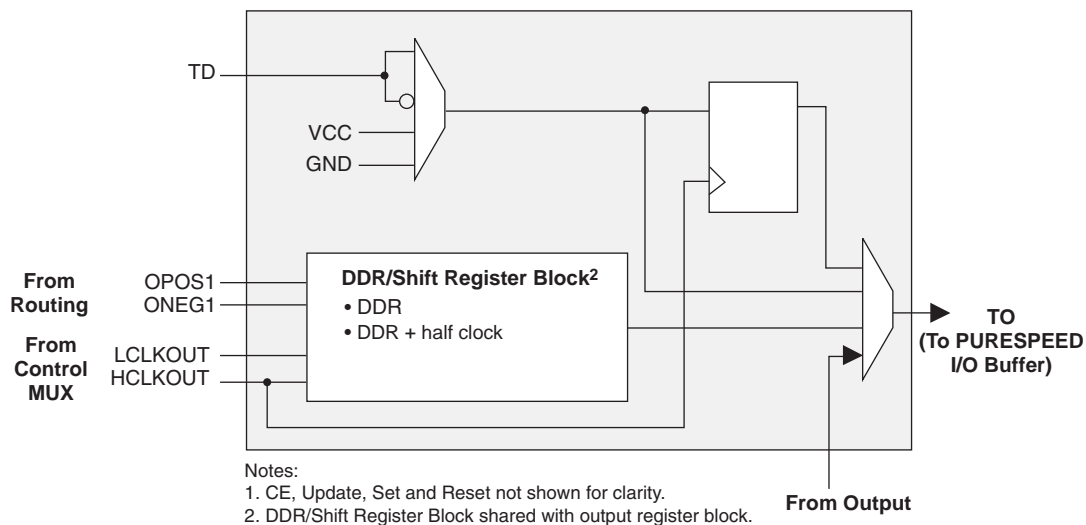

I/O Architecture Rules

Table 2-6 shows the PIO usage for x1, x2, x4 gearing. The checkmarks in the columns show the specific PIOs that are used for each gearing mode. When using x2 or x4 gearing, any PIO which is not used for gearing can still be used as an output.

Table 2-6. Input/Output/Tristate Gearing Resource Rules

PIO	Input/Output Logic			Tri-State/Bidi	
	x1	x2	x4	x1	x2/x4
A	?	?	?	?	N/A
B	?	No I/O Logic	No I/O Logic	?	N/A
C	?	?	No I/O Logic	?	N/A
D	?	No I/O Logic	No I/O Logic	?	N/A

Note: Pin can still be used without I/O logic.

Control Logic Block

The control logic block allows the modification of control signals selected by the routing before they are used in the PIO. It can optionally invert all signals passing through it except the Global Set/Reset. Global Set/Reset can be enabled or disabled. It can route either the edge clock or the clock to the high-speed clock nets. The clock provided to the PIO by routing is used as the slow-speed clocks. In addition this block contains delays that can be inserted in the clock nets to enable Lattice’s unique cycle boosting capability.

Update Block

The update block is used to generate the POS update and NEG update signals used by the DDR/Shift register blocks within the PIO. Note the update block is only required in shift modes. This is required in order to do the high speed to low speed handoff. One of these update signals is also selected and output from the PIC as the signal UPDATE. It consists of a shift chain that operates off either the high-speed input or output clock. The values of each register in the chain are set or reset depending on the desired mode of operation. The set/reset signal is generated from either the edge reset ELSR or the local reset LSR. These signals are optionally inverted by the Control Logic Block and provided to the update block as ELSRUP and LSRUP. The Lattice design tools automatically configure and connect the update block when one of the DDR or shift register primitives is used.

Figure 2-25. Update Block

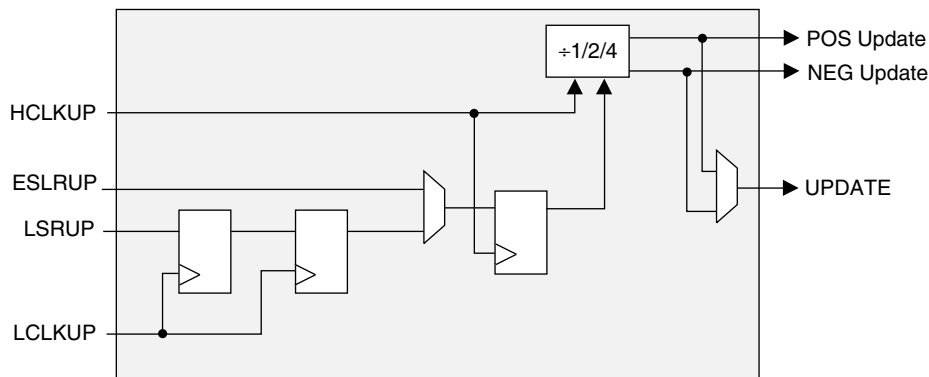

PURESPEED I/O Buffer

Each I/O is associated with a flexible buffer referred to as PURESPEED I/O buffer. These buffers are arranged around the periphery of the device in seven groups referred to as Banks. The PURESPEED I/O buffers allow users to implement the wide variety of standards that are found in today’s systems including LVCMOS, SSTL, HSTL, LVDS and LVPECL. The availability of programmable on-chip termination for both input and output use, further enhances the utility of these buffers.

PURESPEED I/O Buffer Banks

LatticeSC devices have seven PURESPEED I/O buffer banks; each is capable of supporting multiple I/O standards. Each PURESPEED I/O bank has its own I/O supply voltage (V_{CCIO}), and two voltage references V_{REF1} and V_{REF2} resources allowing each bank to be completely independent from each other. Figure 2-26 shows the seven banks and their associated supplies. Table 2-7 lists the maximum number of I/Os per bank for the whole LatticeSC family.

In the LatticeSC devices, single-ended output buffers and ratioed input buffers (LVTTTL, LVCMOS, PCI33 and PCIX33) are powered using V_{CCIO} . In addition to the bank V_{CCIO} supplies, the LatticeSC devices have a V_{CC} core logic power supply, and a V_{CCAUX} supply that power all differential and referenced buffers. V_{CCAUX} also powers a predriver of single-ended output buffers to enhance buffer performance.

Each bank can support up to two separate VREF voltages, VREF1 and VREF2 that set the threshold for the referenced input buffers. In the LatticeSC devices any I/O pin in a bank can be configured to be a dedicated reference voltage supply pin. Each I/O is individually configurable based on the bank's supply and reference voltages.

Differential drivers have user selectable internal or external bias. External bias is brought in by the VREF1 pin in the bank. External bias for differential buffers is needed for applications that requires tighter than standard output common mode range.

Since a bank can have only one external bias circuit for differential drivers, LVDS and RSDS differential outputs can be mixed in a bank.

If a differential driver is configured in a bank, one pin in that bank becomes a DIFFR pin. This DIFFR pin must be connected to ground via an external 1K +/-1% ohm resistor. Note that differential drivers are not supported in banks 1, 4 and 5.

In addition, there are dedicated Terminating Supply (V_{TT}) pins to be used as terminating voltage for one of the two ways to perform parallel terminations. These V_{TT} pins are available in banks 2-7, these pins are not available in some packages. When VTT termination is not required, or used to provide the common mode termination voltage (VCMT), these pins can be left unconnected on the device. If the internal or external VCMT function for differential input termination is used, the VTT pins should be unconnected and allowed to float.

There are further restrictions on the use of V_{TT} pins, for additional details refer to technical information at the end of this data sheet.

Figure 2-26. LatticeSC Banks

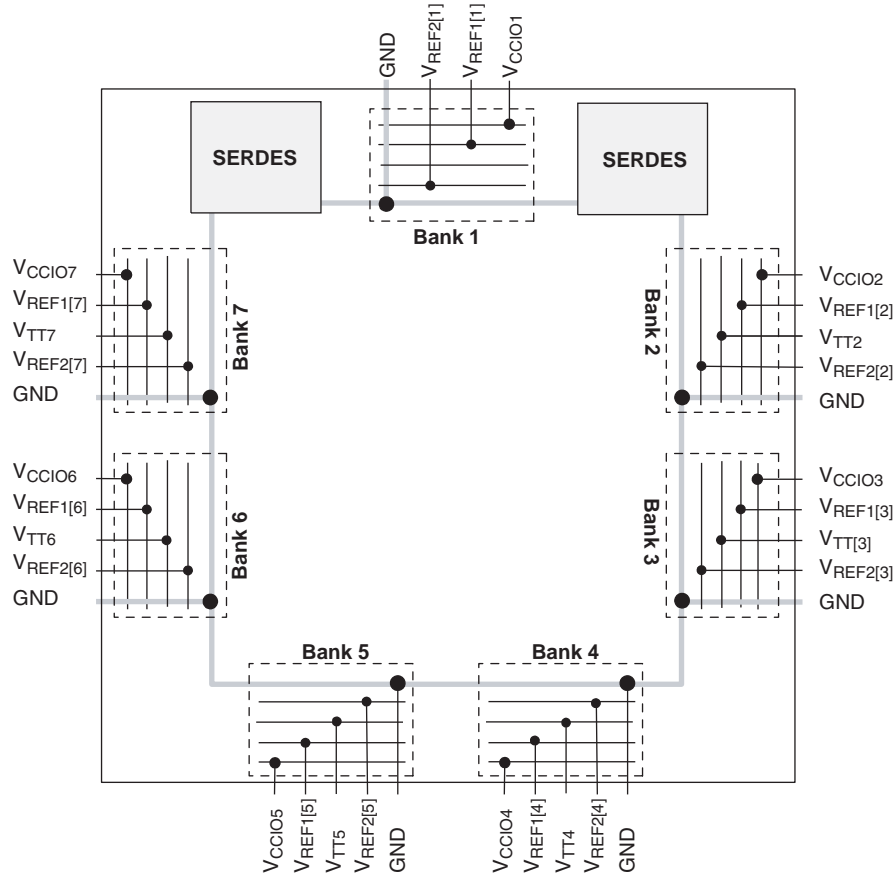

Table 2-7. Maximum Number of I/Os Per Bank in LatticeSC Family

Device	LFSC/M15	LFSC/M25	LFSC/M40	LFSC/M80	LFSC/M115
Bank1	104	80	136	80	136
Bank2	28	36	60	96	136
Bank3	60	84	96	132	156
Bank4	72	100	124	184	208
Bank5	72	100	124	184	208
Bank6	60	84	96	132	156
Bank7	28	36	60	96	136

Note: Not all the I/Os of the Banks are available in all the packages

The LatticeSC devices contain three types of PURESPEED I/O buffers:

1. **Left and Right Sides (Banks 2, 3, 6 and 7)**

These buffers can support LVCMOS standards up to 2.5V. A differential output driver (for LVDS and RSDS) is provided on all primary PIO pairs (A and B) and differential receivers are available on all pairs. Complimentary drivers are available. Adaptive input logic is available on PIOs A or C.

2. **Top Side (Bank 1)**

These buffers can support LVCMOS standards up to 3.3V, including PCI33, PCI-X33 and SSTL-33. Differential receivers are provided on all PIO pairs but differential drivers for LVDS and RSDS are not available. Adaptive input logic is not available on this side. Complimentary output drivers are available.

3. Bottom Side (Banks 4 and 5)

These buffers can support LVCMOS standards up to 3.3V, including PCI33, PCI-X33 and SSTL-33. Differential receivers are provided on all PIO pairs but true HLVDS and RSDS differential drivers are not available. Adaptive input logic is available on PIOs A or C.

Table 2-8 lists the standards supported by each side.

Table 2-8. I/O Standards Supported by Different Banks

Description	Top Side Banks 1	Right Side Banks 2-3	Bottom Side Banks 4-5	Left Side Banks 6-7
I/O Buffer Type	Single-ended, Differential Receiver	Single-ended, Differential Receiver and Driver	Single-ended, Differential Receiver	Single-ended, Differential Receiver and Driver
Output Standards Supported	LVTTTL LVCMOS33 LVCMOS25 LVCMOS18 LVCMOS15 LVCMOS12 SSTL18_I, II SSTL25_I, II SSTL33_I, II HSTL15_I, II, III ¹ , IV ¹ HSTL18_I, II, III ¹ , IV ¹ SSTL18D_I, II SSTL25D_I, II SSTL33D_I, II HSTL15D_I, II HSTL18D_I, II PCI33 PCIX15 PCIX33 AGP1X33 AGP2X33 MLVDS/BLVDS GTL ² , GTL+ ²	LVCMOS25 LVCMOS18 LVCMOS15 LVCMOS12 SSTL18_I, II SSTL25_I, II HSTL15_I, III HSTL18_I, II, III PCIX15 SSTL18D_I, II SSTL25D_I, II HSTL15D_I, II HSTL18D_I, II LVDS/RSDS Mini-LVDS MLVDS/BLVDS GTL ² , GTL+ ²	LVTTTL LVCMOS33 LVCMOS25 LVCMOS18 LVCMOS15 LVCMOS12 SSTL18_I, II SSTL25_I, II SSTL33_I, II HSTL15_I, II, III ¹ , IV ¹ HSTL18_I, II, III ¹ , IV ¹ SSTL18D_I, II SSTL25D_I, II SSTL33D_I, II HSTL15D_I, II HSTL18D_I, II PCI33 PCIX15 PCIX33 AGP1X33 AGP2X33 MLVDS/BLVDS GTL ² , GTL+ ²	LVCMOS25 LVCMOS18 LVCMOS15 LVCMOS12 SSTL18_I, II SSTL25_I, II HSTL15_I, III HSTL18_I, II, III PCIX15 SSTL18D_I, II SSTL25D_I, II HSTL15D_I, II HSTL18D_I, II LVDS/RSDS Mini-LVDS MLVDS/BLVDS GTL ² , GTL+ ²
Input Standards Supported	Single-ended, Differential	Single-ended, Differential	Single-ended, Differential	Single-ended, Differential
Clock Inputs	Single-ended, Differential	Single-ended, Differential	Single-ended, Differential	Single-ended, Differential
Differential Output Support via Emulation	LVDS/MLVDS/BLVDS/ LVPECL	MLVDS/BLVDS/ LVPECL	LVDS/MLVDS/BLVDS/ LVPECL	MLVDS/BLVDS/ LVPECL
ALL Support	No	Yes	Yes	Yes

1. Input only.

2. Input only. Outputs supported by bussing multiple outputs together.

Supported Standards

The LatticeSC PURESPEED I/O buffer supports both single-ended and differential standards. Single-ended standards can be further subdivided into LVCMOS, LVTTTL and other standards. The buffers support the LVTTTL, LVCMOS 12, 15, 18, 25 and 33 standards. In the LVCMOS and LVTTTL modes, the buffer has individually configurable options for drive strength, termination resistance, bus maintenance (weak pull-up, weak pull-down, or a bus-keeper latch) and open drain. Other single-ended standards supported include SSTL, HSTL, GTL (input only), GTL+ (input only), PCI33, PCIX33, PCIX15, AGP-1X33 and AGP-2X33. Differential standards supported include LVDS, RSDS, BLVDS, MLVDS, LVPECL, differential SSTL and differential HSTL. Tables 12 and 13 show the I/O standards (together with their supply and reference voltages) supported by the LatticeSC devices. The tables also provide the available internal termination schemes. For further information on utilizing the PURESPEED I/O buffer to support a variety of standards please see details of additional technical documentation at the end of this data sheet.

Table 2-9. Supported Input Standards

Input Standard	V _{REF} (Nom.)	V _{CCIO} ¹ (Nom.)	On-chip Termination
Single Ended Interfaces			
LVTTTL33 ³	—	3.3	None
LVC MOS 33, 25, 18, 15, 12 ³	—	3.3/2.5/1.8/1.5/1.2	None
PCI33, PCIX33, AGP1X33 ³	—	3.3	None
PCIX15	0.75	1.5 ²	None / V _{CCIO} /2: 50, 60/ V _{TT} : 60, 75, 120, 210
AGP2X33	1.32	—	None
HSTL18_I, II	0.9	1.8 ²	None / V _{CCIO} /2: 50, 60/ V _{TT} : 60, 75, 120, 210
HSTL18_III, IV	1.08	1.8 ²	None / V _{CCIO} : 50
HSTL15_I, II	0.75	1.5 ²	None / V _{CCIO} /2: 50, 60/ V _{TT} : 60, 75, 120, 210
HSTL15_III, IV	0.9	1.5 ²	None / V _{CCIO} : 50
SSTL33_I, II	1.5	3.3	None
SSTL25_I, II	1.25	2.5 ²	None / V _{CCIO} /2: 50, 60/ V _{TT} : 60, 75, 120, 210
SSTL18_I, II	0.9	1.8 ²	None / V _{CCIO} /2: 50, 60/ V _{TT} : 60, 75, 120, 210
GTL+, GTL	1.0 / 0.8	1.5 / 1.2 ²	None / V _{CCIO} : 50
Differential Interfaces			
SSTL18D_I, II	—	1.8 ²	None / Diff: 120, 150, 220, 420/ Diff to V _{CMT} : 120, 150, 220, 420 / V _{CCIO} /2: 50, 60/ V _{TT} : 60, 75, 120, 210
SSTL25D_I, II	—	2.5 ²	None / Diff: 120, 150, 220, 420/ Diff to V _{CMT} : 120, 150, 220, 420 / V _{CCIO} /2: 50, 60/ V _{TT} : 60, 75, 120, 210
SSTL33D_I, II	—	3.3	None
HSTL15D_I, II	—	1.5 ²	None / Diff: 120, 150, 220, 420/ Diff to V _{CMT} : 120, 150, 220, 420 / V _{CCIO} /2: 50, 60/ V _{TT} : 60, 75, 120, 210
HSTL18D_I, II	—	1.8 ²	None / Diff: 120, 150, 220, 420/ Diff to V _{CMT} : 120, 150, 220, 420 / V _{CCIO} /2: 50, 60/ V _{TT} : 60, 75, 120, 210
LVDS	—	—	None / Diff: 120, 150, 220, 240/ Diff to V _{CMT} : 120, 150, 220, 240
Mini-LVDS	—	—	None / Diff: 120, 150 / Diff to V _{CMT} : 120, 150
BLVDS25	—	—	None
MLVDS25	—	—	None
RSDS	—	—	None / Diff: 120, 150, 220, 240/ Diff to V _{CMT} : 120, 150, 220, 240
LVPECL33	—	≤2.5	None / Diff: 120, 150, 220, 240/ Diff to V _{CMT} : 120, 150, 220, 240

1. When not specified V_{CCIO} can be set anywhere in the valid operating range.

2. V_{CCIO} needed for on-chip termination to V_{CCIO}/2 or V_{CCIO} only. V_{CCIO} is not specified for off-chip termination or V_{TT} termination.

3. All ratioed input buffers and dedicated pin input buffers include hysteresis with a typical value of 50mV.

Table 2-10. Supported Output Standards⁴

Output Standard	Drive	V _{CCIO} (Nom)	On-chip Output Termination
Single-ended Interfaces			
LVTTTL/D ¹	8mA, 16mA, 24mA	3.3	None.
LVC MOS33/D ¹	8mA, 16mA, 24mA	3.3	None
LVC MOS25/D ^{1,2}	4mA, 8mA, 12mA, 16mA,	2.5	None, series: 25, 33, 50, 100
LVC MOS18/D ^{1,2}	4mA, 8mA, 12mA, 16mA,	1.8	None, series: 25, 33, 50, 100
LVC MOS15/D ^{1,2}	4mA, 8mA, 12mA, 16mA,	1.5	None, series: 25, 33, 50, 100
LVC MOS12/D ^{1,2}	2mA, 4mA, 8mA, 12mA	1.2	None, series: 25, 33, 50, 100
PCIX15	N/A	1.5	None
PCI33, PCIX33, AGP1X33, AGP2X33	N/A	3.3	None
HSTL18_I	N/A	1.8	None, series: 50
HSTL18_II	N/A	1.8	None, series: 25, series + parallel to V _{CCIO} / 2: 25 + 60
HSTL15_I	N/A	1.5	None, series: 50
HSTL15_II	N/A	1.5	None, series: 25, series + parallel to V _{CCIO} / 2: 25 + 60
SSTL33_I	N/A	3.3	None
SSTL33_II	N/A	3.3	None
SSTL25_I	N/A	2.5	None, series: 50
SSTL25_II	N/A	2.5	None, series: 33, series + parallel to V _{CCIO} / 2: 33+ 60
SSTL18_I	N/A	1.8	None, series: 33
SSTL18_II	N/A	1.8	None, series: 33, series + parallel to V _{CCIO} / 2: 33+ 60
Differential Interfaces			
SSTL18D_I	N/A	1.8	None, series: 33
SSTL25D_I	N/A	2.5	None, series: 50
SSTL18D_II, SSTL25D_II	N/A	1.2/2.5/3.3	None, series: 33, series + parallel to V _{CCIO} / 2: 33+ 60
SSTL33D_I, II	N/A	3.3	None
HSTL15D_I, HSTL18D_I	N/A	1.5/1.8	None, series: 50
HST15D_II, HSTL18D_II	N/A	1.5/1.8	None, series: 25, series + parallel to V _{CCIO} / 2: 25 + 60
LVDS	2mA, 3.5mA, 4mA, 6mA	N/A	None
Mini-LVDS	3.5mA, 4mA, 6mA	N/A	None
BLVDS25	N/A	N/A	None
MLVDS25	N/A	N/A	None
LVPECL33 ³	N/A	3.3	None
RSDS	2mA, 3.5mA, 4mA, 6mA	N/A	None

1. D refers to open drain capability.

2. User can select either drive current or driver impedances but not both.

3. Emulated with external resistors.

4. No GTL or GTL+ support.

PCI Clamp

A programmable PCI clamp is available on the top and bottom banks of the device. The PCI clamp can be turned "ON" or "OFF" on each pin independently. The PCI clamp is used when implementing a 3.3V PCI interface. The

PCI Specification, Revision 2.2 requires the use of clamping diodes for 3.3V operation. For more information on the PCI interface, please refer to the PCI Specification, Revision 2.2.

Programmable Slew Rate Control

All output and bidirectional buffers have an optional programmable output slew rate control that can be configured for either low noise or high-speed performance. Each I/O pin has an individual slew rate control. This allows designers to specify slew rate control on a pin-by-pin basis. This slew rate control affects both the rising and falling edges.

Programmable Termination

Many of the I/O standards supported by the LatticeSC devices require termination at the transmitter, receiver or both. The SC devices provide the capability to implement many kinds of termination on-chip, minimizing stub lengths and hence improving performance. Utilizing this feature also has the benefit of reducing the number of discrete components required on the circuit board. The termination schemes can be split into two categories single-ended and differential.

Single Ended Termination

Single Ended Outputs: The SC devices support a number of different terminations for single ended outputs:

- Series
- Parallel to V_{CCIO} or GND
- Parallel to $V_{CCIO}/2$
- Parallel to $V_{CCIO}/2$ combined with series

Figure 2-27 shows the single ended output schemes that are supported. The nominal values of the termination resistors are shown in Table 2-10.

Figure 2-27. Output Termination Schemes

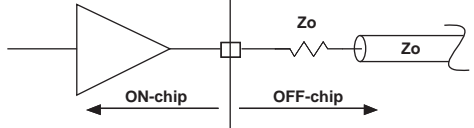
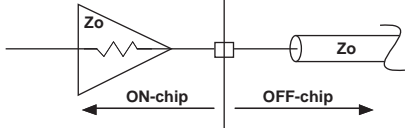
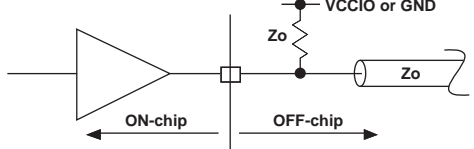
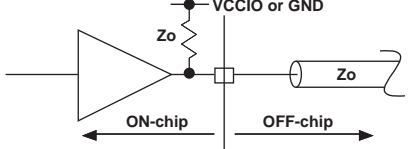
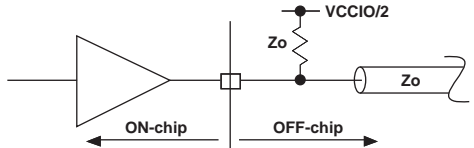
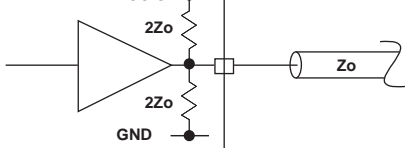
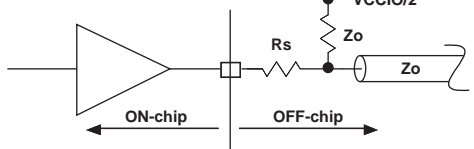
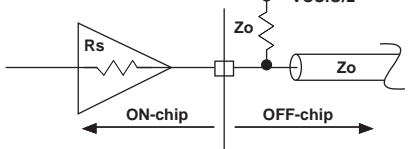
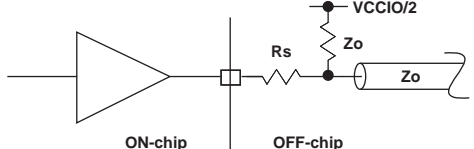
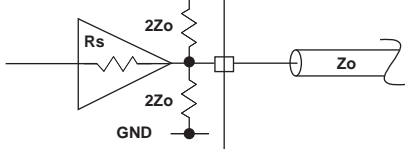
Termination Type	Discrete Off-Chip Solution	Lattice On-Chip Solution
Series termination (controlled output impedance)		
Parallel termination to V _{CCIO} or parallel driving end		
Parallel termination to V _{CCIO} /2 driving end		
Combined series + parallel termination to V _{CCIO} /2 at driving end (only series termination moved on-chip)		
Combined series + parallel to V _{CCIO} /2 driving end		

Single Ended Inputs: The SC devices support a number of different termination schemes for single ended inputs:

- Parallel to V_{CCIO} or GND
- Parallel to $V_{CCIO}/2$
- Parallel to V_{TT}

Figure 2-28 shows the single ended input schemes that are supported. The nominal values of the termination resistors are shown in Table 2-9.

Figure 2-28. Input Termination Schemes

Termination Type	Discrete Off-Chip Solution	Lattice On-Chip Solution
Parallel termination to V_{CCIO} , or parallel to GND receiving end		
Parallel termination to $V_{CCIO}/2$ receiving end		
Parallel termination to V_{TT} at receiving end		

In many situations designers can chose whether to use Thevenin or parallel to V_{TT} termination. The Thevenin approach has the benefit of not requiring a termination voltage to be applied to the device. The parallel to V_{TT} approach consumes less power.

VTT Termination Resources

Each I/O bank, except bank 1, has a number of V_{TT} pins that must be connected if V_{TT} is used. Note V_{TT} pins can sink or source current and the power supply they are connected to must be able to handle the relatively high currents associated with the termination circuits. Note: V_{TT} is not available in all package styles.

On-chip parallel termination to V_{TT} is supported at the receiving end only. On-chip parallel output termination to V_{TT} is not supported.

The V_{TT} internal bus is also connected to the internal V_{CMT} node. Thus in one bank designers can implement either V_{TT} termination or V_{CMT} termination for differential inputs.

DDRII/RLDRAMII Termination Support

The DDR II memory and RLDRAMII (in Bidirection Data mode) standards require that the on-chip termination to V_{TT} be turned on when a pin is an input and off when the pin is an output. The LatticeSC devices contain the required circuitry to support this behavior. For additional detail refer to technical information at the end of the data sheet.

Differential Input Termination

The LatticeSC device allows two types of differential termination. The first is a single resistor across the differential inputs. The second is a center-tapped system where each input is terminated to the on-chip termination bus V_{CMT} . The V_{CMT} bus is DC-coupled through an internal capacitor to ground.

Figure 2-29 shows the differential termination schemes and Table 2-9 shows the nominal values of the termination resistors.

Figure 2-29. Differential Termination Scheme

Termination Type	Discrete Off-Chip Solution	Lattice On-Chip Solution
Differential termination		
Differential and common mode termination		

Calibration

There are two calibration sources that are associated with the termination scheme used in the LatticeSC devices:

- DIFFR – This pin occurs in each bank that supports differential drivers and must be connected through a 1K+/-1% resistor to ground if differential outputs are used. Note that differential drivers are not supported in banks 1, 4 and 5.
- XRES – There is one of these pins per device. It is used for several functions including calibrating on-chip termination. This pin should always be connected through a 1K+/-1% resistor to ground.

The LatticeSC devices support two modes of calibration:

- Continuous – In this mode the SC devices continually calibrate the termination resistances. Calibration happens several times a second. Using this mode ensures that termination resistances remain calibrated as the silicon junction temperature changes.
- User Request – In this mode the calibration circuit operates continuously. However, the termination resistor values are only updated on the assertion of the calibration_update signal available to the core logic.

For more information on calibration, refer to the details of additional technical documentation at the end of this data sheet.

Hot Socketing

The LatticeSC devices have been carefully designed to ensure predictable behavior during power-up and power-down. To ensure proper power sequencing, care must be taken during power-up and power-down as described below. During power-up and power-down sequences, the I/Os remain in tristate until the power supply voltage is high enough to ensure reliable operation. In addition, leakage into I/O pins is controlled to within specified limits,

this allows for easy integration with the rest of the system. These capabilities make the LatticeSC ideal for many multiple power supply and hot-swap applications. The maximum current during hot socketing is 4mA. See Hot Socketing Specifications in Chapter 3 of this data sheet.

Power-Up Requirements

To prevent high power supply and input pin currents, each VCC, VCC12, VCCAUX, VCCIO and VCCJ power supplies must have a monotonic ramp up time of 75 ms or less to reach its minimum operating voltage. Apart from VCC and VCC12, which have an additional requirement, and VCCIO and VCCAUX, which also have an additional requirement, the VCC, VCC12, VCCAUX, VCCIO and VCCJ power supplies can ramp up in any order, with no restriction on the time between them. However, the ramp time for each must be 75 ms or less. Configuration of the device will not proceed until the last power supply has reached its minimum operating voltage.

Additional Requirement for VCC and VCC12:

VCC12 must always be higher than VCC. This condition must be maintained at ALL times, including during power-up and power-down. Note that for 1.2V only operation, it is advisable to source both of these supplies from the same power supply.

Additional Requirement for VCCIO and VCCAUX:

If any VCCIOs are 1.2/1.5/1.8V, then VCCAUX MUST be applied before them. If any VCCIO is 1.2/1.5/1.8V and is powered up before VCCAUX, then when VCCAUX is powered up, it may drag VCCIO up with it as it crosses through the VCCIO value. (Note: If the VCCIO supply is capable of sinking current, as well as the more usual sourcing capability, this behavior is eliminated. However, the amount of current that the supply needs to sink is unknown and is likely to be in the hundreds of milliamps range).

Power-Down Requirements

To prevent high power supply and input pin currents, power must be removed monotonically from either VCC or VCCAUX (and must reach the power-down trip point of 0.5V for VCC, 0.95V for VCCAUX) before power is removed monotonically from VCC12, any of the VCCIOs, or VCCJ. Note that VCC12 can be removed at the same time as VCC, but it cannot be removed earlier. In many applications, VCC and VCC12 will be sourced from the same power supply and so will be removed together. For systems where disturbance of the user pins is a don't care condition, the power supplies can be removed in any order as long as they power down monotonically within 200ms of each other.

Additionally, if any banks have VCCIO=3.3V nominal (potentially banks 1, 4, 5) then VCCIO for those banks must not be lower than VCCAUX during power-down. The normal variation in ramp-up times of power supplies and voltage regulators is not a concern here.

Note: The SERDES power supplies are NOT included in these requirements and have no specific sequencing requirements. However, when using the SERDES with VDDIB or VDDOB that is greater than 1.2V (1.5V nominal for example), the SERDES should not be left in a steady state condition with the 1.5V power applied and the 1.2V power not applied. Both the 1.2V and 1.5V power should be applied to the SERDES at nominally the same time. The normal variation in the ramp-up times of power supplies and voltage regulators is not a concern here.

SERDES Power Supply Sequencing Requirements

When using the SERDES with 1.5V VDDIB or VDDOB supplies, the SERDES should not be left in a steady state condition with the 1.5V power applied and the 1.2V power not applied. Both the 1.2V and the 1.5V power should be applied to the SERDES at nominally the same time. The normal variation in ramp-up times of power supplies and voltage regulators is not a concern.

Additional Requirement for SERDES Power Supply

All VCC12 pins need to be connected on all devices independent of functionality used on the device. This analog supply is used by both the RX and TX portions of the SERDES and is used to control the core SERDES logic regardless of the SERDES being used in the design. VDDIB and VDDOB are used as supplies for the terminations on the CML input and output buffers. If a particular channel is not used, these can be UNCONNECTED (floating).

VDDAX25 needs to be connected independent of the use of the SERDES. This supply is used to control the SERDES CML I/O regardless of the SERDES being used in the design.

Supported Source Synchronous Interfaces

The LatticeSC devices contain a variety of hardware, such as delay elements, DDR registers and PLLs, to simplify the implementation of Source Synchronous interfaces. Table 2-11 lists Source Synchronous and DDR/QDR standards supported in the LatticeSC. For additional detail refer to technical information at the end of the data sheet.

Table 2-11. Source Synchronous Standards Table¹

Source Synchronous Standard	Clocking	Speeds (MHz)	Data Rate (Mbps)
RapidIO	DDR	500	1000
SPI4.2 (POS-PHY4)/NPSI	DDR	500	1000
SFI4/XSBI	DDR SDR	334 667	667
XGMII	DDR	156.25	312
CSIX	SDR	250	250
QDRII/QDRII+ memory interface	DDR	300	600
DDR memory interface	DDR	240	480
DDRII memory interface	DDR	333	667
RLDRAM memory interface	DDR	400	800

1. Memory width is dependent on the system design and limited by the number of I/Os in the device.

flexiPCS™ (Physical Coding Sublayer Block)

flexiPCS Functionality

The LatticeSC family combines a high-performance FPGA fabric, high-performance I/Os and large embedded RAM in a single industry leading architecture. LatticeSC devices also feature up to 32 channels of embedded SERDES with associated Physical Coding Sublayer (PCS) logic. The flexiPCS logic can be configured to support numerous industry standard high-speed data transfer protocols.

Each channel of flexiPCS logic contains dedicated transmit and receive SERDES for high-speed, full-duplex serial data transfers at data rates up to 3.8 Gbps. The PCS logic in each channel can be configured to support an array of popular data protocols including SONET (STS-12/STS-12c, STS-48/STS-48c, and TFI-5 support of 10 Gbps or above), Gigabit Ethernet (compliant to the IEEE 100BASE-X specification), 1.02 or 2.04 Gbps Fibre Channel, PCI-Express, and Serial RapidIO. In addition, the protocol based logic can be fully or partially bypassed in a number of configurations to allow users flexibility in designing their own high-speed data interface.

Protocols requiring data rates above 3.8 Gbps can be accommodated by dedicating either one pair or all four channels in one flexiPCS quad block to one data link. One quad can support full-duplex serial data transfers at data rates up to 15.2 Gbps. A single flexiPCS quad can be configured to support 10Gb Ethernet (with a fully compliant XAUI interface), 10Gb Fibre Channel, and x4 PCI-Express and 4x RapidIO.

The flexiPCS also provides bypass modes that allow a direct 8-bit or 10-bit interface from the SERDES to the FPGA logic which can also be geared to run at 1/2 speed for a 16-bit or 20-bit interface to the FPGA logic. Each SERDES pin can be DC coupled independently and can allow for both high-speed and low-speed operation down to DC rates on the same SERDES pin, as required by some Serial Digital Video applications.

The ispLEVER design tools from Lattice support all modes of the flexiPCS. Most modes are dedicated to applications associated with a specific industry standard data protocol. Other more general purpose modes allow a user to define their own operation. With ispLEVER, the user can define the mode for each quad in a design. Nine modes are currently supported by the ispLEVER design flow:

- 8-bit SERDES Only
- 10-bit SERDES Only
- SONET (STS-12/STS-48)
- Gigabit Ethernet
- Fibre Channel
- XAUI
- Serial RapidIO
- PCI-Express
- Generic 8b10b

flexiPCS Quad

The flexiPCS logic is arranged in quads containing logic for four independent full-duplex data channels. Each device in the LatticeSC family has up to eight quads of flexiPCS logic. The LatticeSC Family Selection Guide table on the first page of this data sheet contains the number of flexiPCS channels present on the chip. Note that in some packages (particularly lower pin count packages), not all channels from all quads on a given device may be bonded to package pins.

Each quad supports up to four channels of full-duplex data and can be programmed into any one of several protocol based modes. Each quad requires its own reference clock which can be sourced externally or from the FPGA logic. The user can utilize between one and four channels in a quad, depending on the application.

Figure 2-30 shows an example of four flexiPCS quads in a LatticeSC device. Quads are labeled according to the address of their software controlled registers.

Figure 2-30. LatticeSC flexiPCS

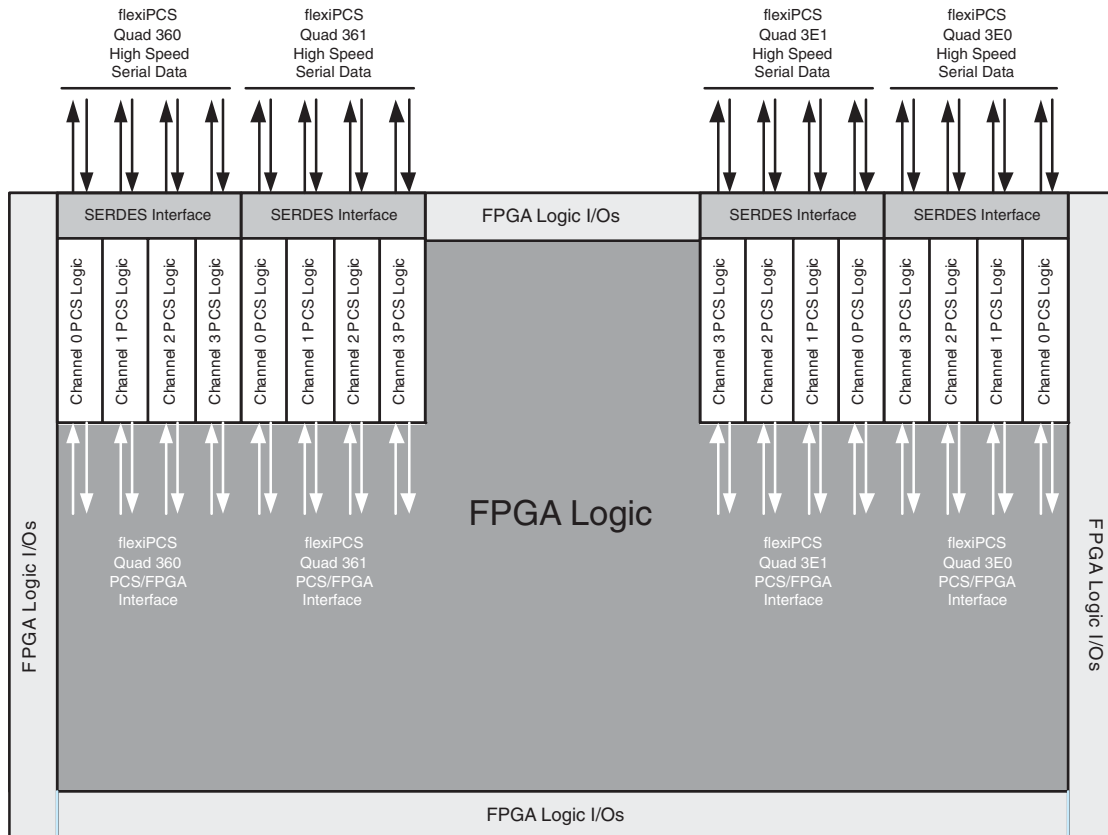

Since each quad has its own reference clock, different quads can support different standards on the same chip. This feature makes the LatticeSC family of devices ideal for bridging between different standards.

flexiPCS quads are not dedicated solely to industry standard protocols. Each quad (and each channel within a quad) can be programmed for many user defined data manipulation modes. For example, modes governing user-defined word alignment and multi-channel alignment can be programmed for non-standard protocol applications.

For more information on the functions and use of the flexiPCS, refer to the [LatticeSC/M Family flexiPCS Data Sheet](#).

System Bus

Each LatticeSC device connects the FPGA elements with a standardized bus framework referred to as a System Bus. Multiple bus masters optimize system performance by sharing resources between different bus masters such as the MPI and configuration logic. The wide data bus configuration of 32 bits with 4-bit parity supports high-bandwidth, data intensive applications.

There are two types of interfaces on the System Bus, master and slave. A master interface has the ability to perform actions on the bus, such as writes and reads to and from a specific address. A slave interface responds to the actions of a master by accepting data and address on a write and providing data on a read. The System Bus has a memory map which describes each of the slave peripherals that is connected on the bus. Using the addresses listed in the memory map, a master interface can access each of the slave peripherals on the System Bus. Any and all peripherals on the System Bus can be used at the same time. Table 2-12 list all of the available user peripherals on the System Bus after device power-up.

Table 2-12. System Bus User Peripherals

Peripheral	Name	Interface Type
Micro Processor Interface	MPI	Master
User Master Interface	UMI	Master
User Slave Interface	USI	Slave
Serial Management Interface (PLL, DLL, User Logic)	SMI	Slave
Physical Coding Sublayer	PCS	Slave
Direct FPGA Access	DFA	Slave

The peripherals listed in Table 2-12 can be added when the System Bus module is created using Module IP/Manager (ispLEVER Module/IP Manager).

Figure 2-31 also lists the existing peripherals on the System Bus. The gray boxes are available only during configuration. Refer to Lattice technical note TN1080, [LatticeSC sysCONFIG Usage Guide](#), for configuration options. The Status and Config box refers to internal System Bus registers. This document presents all the interfaces listed in Table 2-12 in detail to help the user utilize the desired functions of the System Bus.

Figure 2-31. LatticeSC System Bus Interfaces

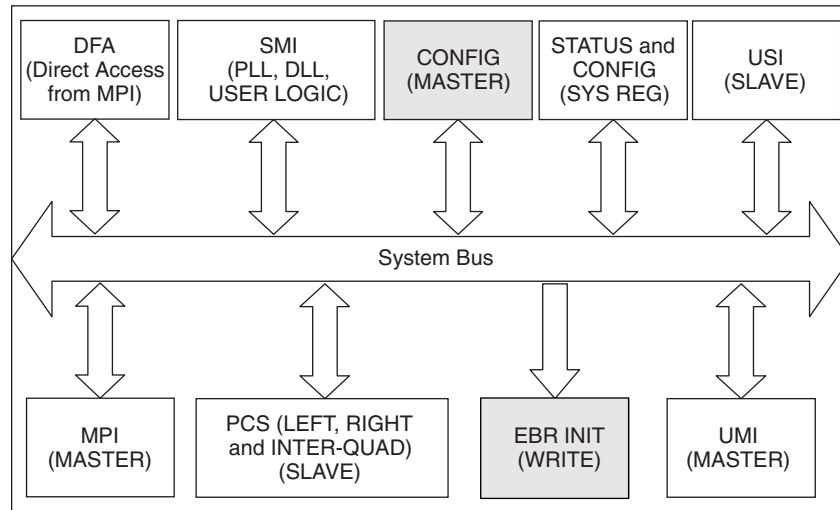

Several interfaces exist between the System Bus and other FPGA elements. The MPI interface acts as a bridge between the external microprocessor bus and System Bus. The MPI may work in an independent clock domain from the System Bus if the System Bus clock is not sourced from the external microprocessor clock. Pipelined operation allows high-speed memory interface to the EBR and peripheral access without the requirement for additional cycles on the bus. Burst transfers allow optimal use of the memory interface by giving advance information of the nature of the transfers.

Details for the majority of the peripherals can be found in the associated technical documentation, see details at the end of this data sheet. Additional details of the MPI are provided below.

Microprocessor Interface (MPI)

The LatticeSC family devices have a dedicated synchronous MPI function block. The MPI is programmable to operate with PowerPC/PowerQUICC MPC860/MPC8260 series microprocessors. The MPI implements an 8-, 16-, or 32-bit interface with 1-bit, 2-bit, or 4-bit parity to the host processor (PowerPC) that can be used for configuration and read-back of the FPGA as well as for user-defined data processing and general monitoring of FPGA functions.

The control portion of the MPI is available following power-up of the FPGA if the mode pins specify MPI mode, even if the FPGA is not yet configured. The width of the data port is selectable among 8-, 16-, or 32-bit and the parity bus can be 1-, 2-, or 4-bit. In configuration mode the data and parity bus width are related to the state of the M[0:3] mode pins. For post-configuration use, the MPI must be included in the configuration bit stream by using an MPI library element in your design from the ispLEVER primitive library, or by setting the bit of the MPI configuration control register prior to the start of configuration. The user can also enable and disable the parity bus through the configuration bit stream. These pads can be used as general I/O when they are not needed for MPI use.

The MPI block also provides the capability to interface directly to the FPGA fabric with a databus after configuration. The bus protocol is still handled by the MPI block but the direct FPGA access allows high-speed block data transfers such as DMA transactions. Figure 2-32 shows one of the ways a PowerPC is connected to MPI.

Figure 2-32. PowerPCI and MPI Schematic

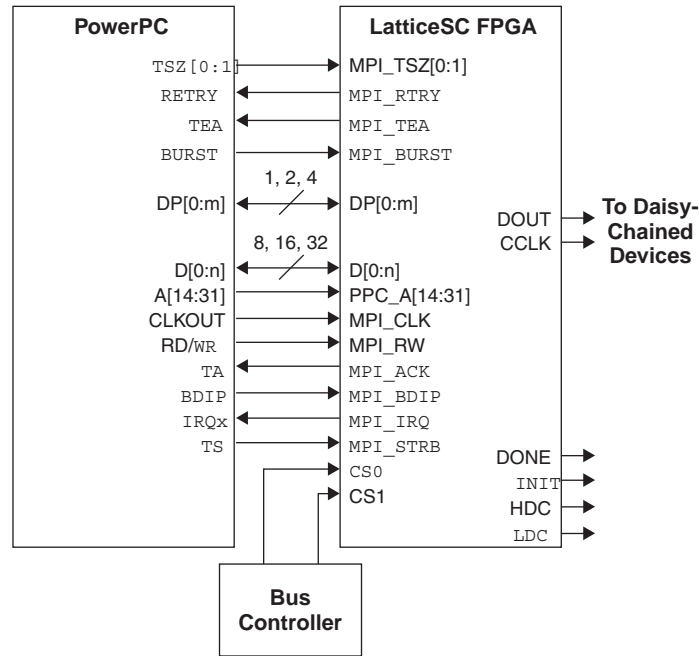

Configuration and Testing

The following section describes the configuration and testing features of the LatticeSC family of devices.

IEEE 1149.1-Compliant Boundary Scan Testability

All LatticeSC devices have boundary scan cells that are accessed through an IEEE 1149.1 compliant test access port (TAP). This allows functional testing of the circuit board, on which the device is mounted, through a serial scan path that can access all critical logic nodes. Internal registers are linked internally, allowing test data to be shifted in and loaded directly onto test nodes, or test data to be captured and shifted out for verification. The test access port consists of dedicated I/Os: TDI, TDO, TCK and TMS. The test access port has its own supply voltage V_{CCJ} and can operate with LVCMOS33, 25 and 18 standards. For additional detail refer to technical information at the end of the data sheet.

Device Configuration

All LatticeSC devices contain three possible ports that can be used for device configuration. The serial port, which supports bit-wide configuration, and the sysCONFIG port that supports both byte-wide and serial configuration. The MPI port supports 8-bit, 16-bit or 32-bit configuration.

The serial port supports both the IEEE Std. 1149.1 Boundary Scan specification and the IEEE Std. 1532 In-System Configuration specification. The sysCONFIG port is a 20-pin interface with six of the I/Os used as dedicated pins and the rest being dual-use pins. When sysCONFIG mode is not used, these dual-use pins are available for general purpose I/O. All I/Os for the sysCONFIG and MPI ports are in I/O bank #1.

On power-up, the FPGA SRAM is ready to be configured with the sysCONFIG port active. The IEEE 1149.1 serial mode can be activated any time after power-up by sending the appropriate command through the TAP port. Once a configuration port is selected, that port is locked and another configuration port cannot be activated until the next re-initialization sequence. For additional detail refer to technical information at the end of the data sheet.

Internal Logic Analyzer Capability (ispTRACY)

All LatticeSC devices support an internal logic analyzer diagnostic feature. The diagnostic features provide capabilities similar to an external logic analyzer, such as programmable event and trigger condition and deep trace memory. This feature is enabled by Lattice's ispTRACY. The ispTRACY utility is added into the user design at compile time. For additional detail refer to technical information at the end of the data sheet.

Temperature Sensing

Lattice provides a way to monitor the die temperature by using a temperature-sensing diode that is designed into every LatticeSC device. The difference in V_{BE} of the diode at two different forward currents varies with temperature. This relationship is shown in Figure 2-33. The accuracy of the temperature-sensing diode is typically $\pm 10^{\circ}\text{C}$.

On packages that include PROBE_GND, the most accurate measurements will occur between the TEMP pin and the PROBE_GND pin. On packages that do not include PROBE_GND, measurements should be made between the TEMP pin and board ground.

This temperature-sensing diode is designed to work with an external temperature sensor such as the Maxim 1617A. The Maxim 1617A is configured to measure difference in V_{BE} (of the temperature-sensing diode) at $10\mu\text{A}$ and at $100\mu\text{A}$. This difference in V_{BE} voltage varies with temperature at approximately $1.64\text{ mV}/^{\circ}\text{C}$. A typical device with a 85°C junction temperature will measure approximately 593mV . For additional detail refer to TN1115, [Temperature Sensing Diode in LatticeSC Devices](#).

Figure 2-33. Sensing Diode Typical Characteristics

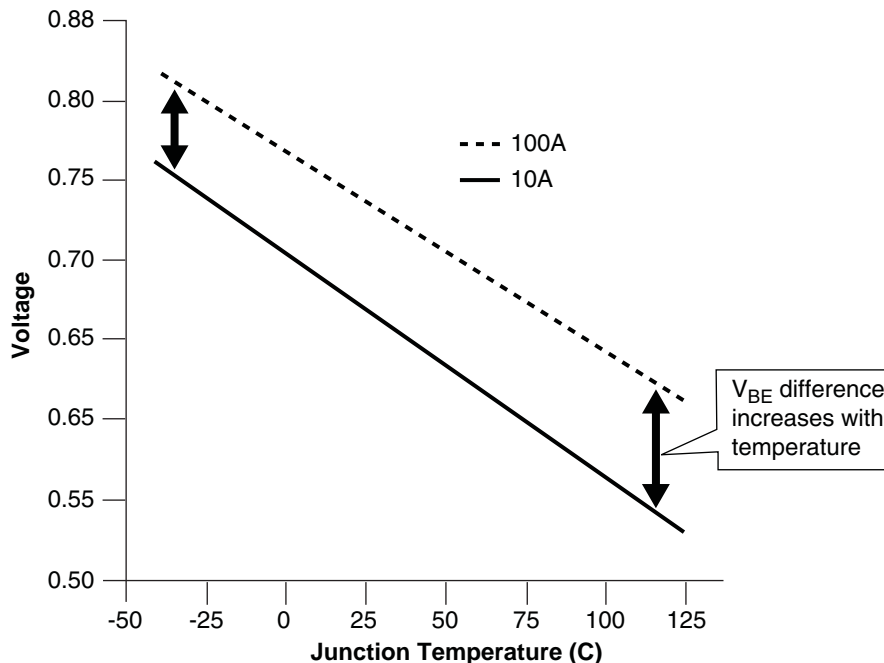

Oscillator

Every LatticeSC device has an internal CMOS oscillator, which is used as a master serial clock for configuration and is also available as a potential general purpose clock (MCK) for the FPGA core. There is a K divider (divide by 2/4/8/16/32/64/128) available with this oscillator to get lower MCK frequencies. This clock is available as a general purpose clock signal to the software routing tool. For additional detail refer to technical information at the end of the data sheet.

Density Shifting

The LatticeSC family has been designed to ensure that different density devices in the same package have the same pin-out. Furthermore, the architecture ensures a high success rate when performing design migration from lower density parts to higher density parts. In many cases, it is also possible to shift a lower utilization design targeted for a high-density device to a lower density device. However, the exact details of the final resource utilization will impact the likely success in each case.

Absolute Maximum Ratings

Supply Voltage V_{CC} , V_{CC12} , V_{DDIB} , V_{DDOB}	-0.5 to 1.6V
Supply Voltage V_{CCAUX} , V_{DDAX25} , V_{TT}	-0.5 to 2.75V
Supply Voltage V_{CCJ}	-0.5 to 3.6V
Supply Voltage V_{CCIO} (Banks 1, 4, 5)	-0.5 to 3.6V
Supply Voltage V_{CCIO} (Banks 2, 3, 6, 7)	-0.5 to 2.75V
Input or I/O Tristate Voltage Applied (Banks 1, 4, 5)	-0.5 to 3.6V
Input or I/O Tristate Voltage Applied (Banks 2, 3, 6, 7)	-0.5 to 2.75V
Storage Temperature (Ambient)	-65 to 150°C
Junction Temperature Under Bias (Tj)	+125°C

Notes:

1. Stress above those listed under the “Absolute Maximum Ratings” may cause permanent damage to the device. Functional operation of the device at these or any other conditions above those indicated in the operational sections of this specification is not implied.
2. Compliance with the Lattice Thermal Management document is required.
3. All voltages referenced to GND.
4. Undershoot and overshoot of -2V to (VIHMAX +2) volts is permitted for a duration of <20ns.

Recommended Operating Conditions

Symbol	Parameter	Min.	Max.	Units
V_{CC}^5	Core Supply Voltage (Nominal 1.2V Operation)	0.95	1.26	V
V_{CCAUX}^6	Programmable I/O Auxiliary Supply Voltage	2.375	2.625	V
$V_{CCIO}^{1,2,5,6}$	Programmable I/O Driver Supply Voltage (Banks 1, 4, 5)	1.14	3.45	V
$V_{CCIO}^{1,2,5,6}$	Programmable I/O Driver Supply Voltage (Banks 2, 3, 6, 7)	1.14	2.625	V
$V_{CC12}^{4,5}$	Internal 1.2V Power Supply Voltage for Configuration Logic and FPGA PLL, SERDES PLL Power Supply Voltage and SERDES Analog Supply Voltage	1.14	1.26	V
V_{DDIB}	SERDES Input Buffer Supply Voltage	1.14	1.575	V
V_{DDOB}	SERDES Output Buffer Supply Voltage	1.14	1.575	V
V_{DDAX25}	SERDES Termination Auxiliary Supply Voltage	2.375	2.625	V
$V_{CCJ}^{1,5}$	Supply Voltage for IEEE 1149.1 Test Access Port	1.71	3.45	V
$V_{TT}^{2,3}$	Programmable I/O Termination Power Supply	0.5	$V_{CCAUX} - 0.5$	V
t_{JCOM}	Junction Temperature, Commercial Operation	0	+85	C
t_{JIND}	Junction Temperature, Industrial Operation	-40	105	C

1. If V_{CCIO} or V_{CCJ} is set to 2.5V, they must be connected to the same power supply as V_{CCAUX} .
2. See recommended voltages by I/O standard in subsequent table.
3. When V_{TT} termination is not required, or used to provide the common mode termination voltage (V_{CMT}), these pins can be left unconnected on the device.
4. V_{CC12} cannot be lower than V_{CC} at any time. For 1.2V operation, it is recommended that the V_{CC} and V_{CC12} supplies be tied together with proper noise decoupling between the digital VCC and analog VCC12 supplies.
5. V_{CC} , V_{CCIO} (all banks), V_{CC12} and V_{CCJ} must reach their minimum values before configuration will proceed.
6. If V_{CCIO} for a bank is nominally 1.2V/1.5V/1.8V, then V_{CCAUX} must always be higher than V_{CCIO} during power up.

© 2011 Lattice Semiconductor Corp. All Lattice trademarks, registered trademarks, patents, and disclaimers are as listed at www.latticesemi.com/legal. All other brand or product names are trademarks or registered trademarks of their respective holders. The specifications and information herein are subject to change without notice.

Power Supply Ramp Rates

Symbol	Parameter	Condition	Min.	Typ.	Max	Units
t_{RAMP}	Power supply ramp rates for all power supplies	Over process, voltage, temperature	3.45	—	—	mV/ μ s
			—	—	75	ms

- See the Power-up and Power-Down requirements section for more details on power sequencing.
- From 0.5V to minimum operating voltage.

Hot Socketing Specifications¹

Symbol	Parameter	Condition	Min.	Typ.	Max	Units
I_{DK}	Programmable and dedicated Input or I/O leakage current ^{2, 3, 4, 5, 6}	$0 \leq V_{\text{IN}} \leq V_{\text{IH}} (\text{MAX})$	—	—	± 1500	μ A
I_{HDIN}	SERDES average input current when device powered down and inputs driven ⁷		—	—	4	mA

- See Hot Socket power up/down information in Chapter 2 of this document.
- Assumes monotonic rise/fall rates for all power supplies.
- Sensitive to power supply sequencing as described in hot socketing section.
- Assumes power supplies are between 0 and maximum recommended operations conditions.
- IDK is additive to I_{PU} , I_{PD} or I_{BH} .
- Represents DC conditions. For the first 20ns after hot insertion, current specification is 8 mA.
- Assumes that the device is powered down with all supplies grounded, both P and N inputs driven by a CML driver with maximum allowed VDDOB of 1.575V, 8b/10b data and internal AC coupling.

DC Electrical Characteristics⁵

Over Recommended Operating Conditions

Symbol	Parameter	Condition	Min. ³	Typ.	Max.	Units
$I_{\text{IL}}, I_{\text{IH}}^1$	Input or I/O Low leakage	$0 \leq V_{\text{IN}} \leq V_{\text{IH}} (\text{MAX})$	—	—	10	μ A
I_{PU}	I/O Active Pull-up Current	$0 \leq V_{\text{IN}} \leq 0.7 V_{\text{CCIO}}$	-30	—	-210	μ A
I_{PD}	I/O Active Pull-down Current	$V_{\text{IL}} (\text{MAX}) \leq V_{\text{IN}} \leq V_{\text{IH}} (\text{MAX})$	30	—	210	μ A
I_{BHLS}	Bus Hold Low Sustaining Current	$V_{\text{IN}} = V_{\text{IL}} (\text{MAX})$	30	—	—	μ A
I_{BHHS}	Bus Hold High Sustaining Current	$V_{\text{IN}} = 0.7V_{\text{CCIO}}$	-30	—	—	μ A
I_{BHLO}	Bus Hold Low Overdrive Current	$0 \leq V_{\text{IN}} \leq V_{\text{IH}} (\text{MAX})$	—	—	210	μ A
I_{BHLH}	Bus Hold High Overdrive Current	$0 \leq V_{\text{IN}} \leq V_{\text{IH}} (\text{MAX})$	—	—	-210	μ A
I_{CL}	PCI Low Clamp Current	$-3 < V_{\text{IN}} \leq -1$	$-25 + (V_{\text{IN}} + 1)/0.015$	—	—	mA
I_{CH}	PCI High Clamp Current	$V_{\text{CC}} + 4 > V_{\text{IN}} \geq V_{\text{CC}} + 1$	$25 + (V_{\text{IN}} - V_{\text{CC}} - 1)/0.015$	—	—	mA
V_{BHT}	Bus Hold trip Points	$0 \leq V_{\text{IN}} \leq V_{\text{IH}} (\text{MAX})$	$V_{\text{IL}} (\text{MAX})$	—	$V_{\text{IH}} (\text{MIN})$	V
C1	I/O Capacitance ²	$V_{\text{CCIO}} = 3.3\text{V}, 2.5\text{V}, 1.8\text{V}, 1.5\text{V}, 1.2\text{V},$ $V_{\text{CC}} = 1.2\text{V}, V_{\text{CCIP2}} = 1.2\text{V},$ $V_{\text{CCAUX}} = 2.5, V_{\text{IO}} = 0 \text{ to } V_{\text{IH}} (\text{MAX})$	—	8	—	pf
C3 ²	Dedicated Input Capacitance ²	$V_{\text{CCIO}} = 3.3\text{V}, 2.5\text{V}, 1.8\text{V}, 1.5\text{V}, 1.2\text{V},$ $V_{\text{CC}} = 1.2\text{V}, V_{\text{CCIP2}} = 1.2\text{V},$ $V_{\text{CCAUX}} = 2.5, V_{\text{IO}} = 0 \text{ to } V_{\text{IH}} (\text{MAX})$	—	6	—	pf

- Input or I/O leakage current is measured with the pin configured as an input or as an I/O with the output driver tri-stated. It is not measured with the output driver active. Bus maintenance circuits are disabled.
- $T_{\text{A}} 25^{\circ}\text{C}$, $f = 1.0\text{MHz}$
- I_{PU} , I_{PD} , I_{BHLS} and I_{BHHS} have minimum values of 15 or $-15\mu\text{A}$ if V_{CCIO} is set to 1.2V nominal.
- This table does not apply to SERDES pins.
- For programmable I/Os.

Initialization and Standby Supply Current

The table below indicates initialization and standby supply current while operating at 85°C junction temperature (T_J), which is the high end of the commercial temperature range, and 105°C, which is the high end of the industrial temperature range. This data assumes all outputs are tri-stated and all inputs are configured as LVCMOS and held at V_{CCIO} or GND. The remaining SERDES supply current for V_{DDIB} and V_{DDOB} is detailed in the SERDES section of this data sheet. For power at your design temperature, it is recommended to use the Power Calculator tool which is accessible in ispLEVER or can be used as a standalone tool. For more information on supply current, see the reference to additional technical documentation available at the end of this data sheet.

Over Recommended Operating Conditions

Symbol	Condition	Parameter	Device	25°C	85°C		105°C	Units	
				Typ. ¹	Max. ²		Max. ²		
				All	-5, -6	-7	-5, -6		
I_{CC}	(VCC = 1.2V +/- 5%)	Core Operating Power Supply Current	LFSC/M15	65	449	678	755	mA	
			LFSC/M25	113	798	1255	1343	mA	
			LFSC/M40	159	1178	2006	1981	mA	
			LFSC/M80	276	2122	3827	3569	mA	
			LFSC/M115	454	3376	—	5679	mA	
	(VCC = 1.0V +/- 5%)	Core Operating Power Supply Current	LFSC/M15	45	312	471	524	mA	
			LFSC/M25	79	554	872	933	mA	
			LFSC/M40	110	818	1393	1375	mA	
			LFSC/M80	191	1473	2658	2478	mA	
			LFSC/M115	315	2344	—	3943	mA	
I_{CC12}		1.2V Power Supply Current for Configuration Logic, FPGA PLL, SERDES PLL and SERDES Analog Supplies	LFSC/M15	23	39	59	35	mA	
			LFSC/M25	25	50	78	56	mA	
			LFSC/M40	31	78	133	89	mA	
			LFSC/M80	50	108	195	123	mA	
			LFSC/M115	65	131	—	154	mA	
I_{CCAUX}		Auxiliary Operating Power Supply Current	LFSC/M15	7	12	19	14	mA	
			LFSC/M25	9	16	25	18	mA	
			LFSC/M40	12	23	39	25	mA	
			LFSC/M80	13	25	45	23	mA	
			LFSC/M115	16	27	—	26	mA	
I_{CCIO} and I_{CCJ}		Bank Power Supply Current (per bank)	LFSC/M15	0.1	0.2	0.3	0.2	mA	
			LFSC/M25	0.3	0.6	1.0	0.7	mA	
			LFSC/M40	0.4	0.9	1.5	1.0	mA	
			LFSC/M80	0.5	1.1	2.1	1.3	mA	
			LFSC/M115	0.7	1.5	—	1.8	mA	

1. I_{CC} is specified at $T_J = 25^\circ\text{C}$ and typical V_{CC} .

2. I_{CC} is specified at the respective commercial and industrial maximum T_J and V_{CC} limits.

PURESPEED I/O Recommended Operating Conditions

Standard	V _{CCIO} (V)			V _{REF} (V)		
	Min.	Typ.	Max.	Min.	Typ.	Max.
LVC MOS 33	3.135	3.3	3.465	—	—	—
LVC MOS 25	2.375	2.5	2.625	—	—	—
LVC MOS 18	1.71	1.8	1.89	—	—	—
LVC MOS 15	1.425	1.5	1.575	—	—	—
LVC MOS 12	1.14	1.2	1.26	—	—	—
LV TTL	3.135	3.3	3.465	—	—	—
PCI33	3.135	3.3	3.465	—	—	—
PCIX33	3.135	3.3	3.465	—	—	—
PCIX15	1.425	1.5	1.575	0.49V _{CCIO}	0.5V _{CCIO}	0.51V _{CCIO}
AGP1X33	3.135	3.3	3.465	—	—	—
AGP2X33	3.135	3.3	3.465	0.39V _{CCIO}	0.4V _{CCIO}	0.41V _{CCIO}
SSTL18_I, II ³	1.71	1.8	1.89	0.833	0.9	0.969
SSTL25_I, II ³	2.375	2.5	2.625	1.15	1.25	1.35
SSTL33_I, II ³	3.135	3.3	3.465	1.3	1.5	1.7
HSTL15_I, II ³	1.425	1.5	1.575	0.68	0.75	0.9
HSTL15_III ^{1,3} and IV ^{1,3}	1.425	1.5	1.575	0.68	0.9	0.9
HSTL 18_I ³ , II ³	1.71	1.8	1.89	0.816	0.9	1.08
HSTL 18_III ^{1,3} , IV ^{1,3}	1.71	1.8	1.89	0.816	1.08	1.08
GTL12 ^{1,3} , GTLPLUS15 ^{1,3}	—	—	—	0.882	1.0	1.122
LVDS	—	—	—	—	—	—
Mini-LVDS	—	—	—	—	—	—
RSDS	—	—	—	—	—	—
LVPECL33 (outputs) ²	3.135	3.3	3.465	—	—	—
LVPECL33 (inputs) ^{2,4}	—	≤ 2.5	—	—	—	—
BLVDS25 ^{2,3}	2.375	2.5	2.625	—	—	—
MLVDS25 ^{2,3}	2.375	2.5	2.625	—	—	—
SSTL18D_I ³ , II ³	1.71	1.8	1.89	—	—	—
SSTL25D_I ³ , II ³	2.375	2.5	2.625	—	—	—
SSTL33D_I ³ , II ³	3.135	3.3	3.465	—	—	—
HSTL15D_I ³ , II ³	1.425	1.5	1.575	—	—	—
HSTL18D_I ³ , II ³	1.71	1.8	1.89	—	—	—

1. Input only.

2. Inputs on chip. Outputs are implemented with the addition of external resistors.

3. Input for this standard does not depend on the value of V_{CCIO}.

4. Inputs for this standard cannot be in 3.3V VCCIO banks (≤ 2.5V only).

PURESPEED I/O Single-Ended DC Electrical Characteristics

Over Recommended Operating Conditions

Input/Output Standard	V_{IL}		V_{IH}		V_{OL} Max. (V)	V_{OH} Min. (V)	I_{OL} (mA)	I_{OH} (mA)
	Min. (V)	Max. (V)	Min. (V)	Max. (V)				
LVC MOS 33	-0.3	0.8	2	3.465	0.4	2.4	24, 16, 8	-24, -16, -8
					0.2	$V_{CCIO} - 0.2$	0.1	-0.1
LV TTL	-0.3	0.8	2	3.465	0.4	2.4	24, 16, 8	-24, -16, -8
					0.2	$V_{CCIO} - 0.2$	0.1	-0.1
LVC MOS 25	-0.3	0.7	1.7	2.65	0.4	$V_{CCIO} - 0.4$	16, 12, 8, 4	-16, -12, -8, -4
					0.2	$V_{CCIO} - 0.2$	0.1	-0.1
LVC MOS 18	-0.3	$0.35V_{CCIO}$	$0.65V_{CCIO}$	2.65	0.4	$V_{CCIO} - 0.4$	16, 12, 8, 4	-16, -12, -8, -4
					0.2	$V_{CCIO} - 0.2$	0.1	-0.1
LVC MOS 15	-0.3	$0.35V_{CCIO}$	$0.65V_{CCIO}$	2.65	0.4	$V_{CCIO} - 0.4$	16, 12, 8, 4	-16, -12, -8, -4
					0.2	$V_{CCIO} - 0.2$	0.1	-0.1
LVC MOS 12	-0.3	$0.35V_{CCIO}$	$0.65V_{CCIO}$	2.65	0.3	$V_{CCIO} - 0.3$	12, 8, 4, 2	-12, -8, -4, -2
					0.2	$V_{CCIO} - 0.2$	0.1	-0.1
PCIX15	-0.3	$0.3V_{CCIO}$	$0.5V_{CCIO}$	1.5	$0.1V_{CCIO}$	$0.9V_{CCIO}$	1.5	-0.5
PCI33	-0.3	$0.3V_{CCIO}$	$0.5V_{CCIO}$	3.465	$0.1V_{CCIO}$	$0.9V_{CCIO}$	1.5	-0.5
PCIX33	-0.3	$0.35V_{CCIO}$	$0.5V_{CCIO}$	3.465	$0.1V_{CCIO}$	$0.9V_{CCIO}$	1.5	-0.5
AGP-1X, AGP-2X	-0.3	$0.3V_{CCIO}$	$0.5V_{CCIO}$	3.465	$0.1V_{CCIO}$	$0.9V_{CCIO}$	1.5	-0.5
SSTL3_I	-0.3	$V_{REF} - 0.2$	$V_{REF} + 0.2$	3.465	0.7	$V_{CCIO} - 1.1$	8	-8
SSTS3_I OST ²	-0.3	$V_{REF} - 0.2$	$V_{REF} + 0.2$	3.465	0.9	$V_{CCIO} - 1.3$	8	-8
SSTL3_II	-0.3	$V_{REF} - 0.2$	$V_{REF} + 0.2$	3.465	0.5	$V_{CCIO} - 0.9$	16	-16
SSTL3_II OST ²	-0.3	$V_{REF} - 0.2$	$V_{REF} + 0.2$	3.465	0.9	$V_{CCIO} - 0.13$	16	-16
SSTL2_I	-0.3	$V_{REF} - 0.18$	$V_{REF} + 0.18$	2.65	0.54	$V_{CCIO} - 0.62$	7.6	-7.6
SSTL2_I OST ²	-0.3	$V_{REF} - 0.18$	$V_{REF} + 0.18$	2.65	0.73	$V_{CCIO} - 0.81$	7.6	-7.6
SSTL2_II	-0.3	$V_{REF} - 0.18$	$V_{REF} + 0.18$	2.65	0.35	$V_{CCIO} - 0.43$	15.2	-15.2
SSTL2_II OST ²	-0.3	$V_{REF} - 0.18$	$V_{REF} + 0.18$	2.65	0.73	$V_{CCIO} - 0.81$	15.2	-15.2
SSTL18_I	-0.3	$V_{REF} - 0.125$	$V_{REF} + 0.125$	2.65	0.28	$V_{CCIO} - 0.28$	13.4	-13.4
SSTL18_II	-0.3	$V_{REF} - 0.125$	$V_{REF} + 0.125$	2.65	0.28	$V_{CCIO} - 0.28$	13.4	-13.4
HSTL15_I	-0.3	$V_{REF} - 0.1$	$V_{REF} + 0.1$	2.65	0.4	$V_{CCIO} - 0.4$	8	-8
HSTL15_II	-0.3	$V_{REF} - 0.1$	$V_{REF} + 0.1$	2.65	0.4	$V_{CCIO} - 0.4$	16	-16
HSTL15_III ¹	-0.3	$V_{REF} - 0.1$	$V_{REF} + 0.1$	2.65	N/A	N/A	N/A	N/A
HSTL15_IV ¹	-0.3	$V_{REF} - 0.1$	$V_{REF} + 0.1$	2.65	N/A	N/A	N/A	N/A
HSTL18_I	-0.3	$V_{REF} - 0.1$	$V_{REF} + 0.1$	2.65	0.4	$V_{CCIO} - 0.4$	9.6	-9.6
HSTL18_II	-0.3	$V_{REF} - 0.1$	$V_{REF} + 0.1$	2.65	0.4	$V_{CCIO} - 0.4$	19.2	-19.2
HSTL18_III ¹	-0.3	$V_{REF} - 0.1$	$V_{REF} + 0.1$	2.65	N/A	N/A	N/A	N/A
HSTL18_IV ¹	-0.3	$V_{REF} - 0.1$	$V_{REF} + 0.1$	2.65	N/A	N/A	N/A	N/A
GTL12 ¹ , GTLPLUS15 ¹	-0.3	$V_{REF} - 0.2$	$V_{REF} + 0.2$	N/A	N/A	N/A	N/A	N/A

1. Input only.

2. Input with on-chip series termination.

PURESPEED I/O Differential Electrical Characteristics**LVDS****Over Recommended Operating Conditions**

Parameter Symbol	Parameter Description	Test Conditions	Min.	Typ.	Max.	Units
V_{INP}, V_{INM}	Input voltage		0	—	2.4	V
V_{THD}	Differential input threshold (Q-Q)		+/-100	—	—	mV
V_{CM}	Input common mode voltage		0.05	1.2	2.35	V
I_{IN}	Input current	Power on or power off	—	—	+/-10	μ A
V_{OH}	Output high voltage for V_{OP} or V_{OM}	$R_T = 100$ Ohm	—	1.38	1.60	V
V_{OL}	Output low voltage for V_{OP} or V_{OM}	$R_T = 100$ Ohm	0.9V	1.03	—	V
V_{OD}	Output voltage differential	$(V_{OP} - V_{OM}), R_T = 100$ Ohm	250	350	450	mV
ΔV_{OD}	Change in V_{OD} between high and low		—	—	50	mV
V_{OS}	Output voltage offset	$(V_{OP} - V_{OM})/2, R_T = 100$ Ohm	1.125	1.20	1.375	V
ΔV_{OS}	Change in V_{OS} between H and L		—	—	50	mV
I_{SAB}	Output short circuit current	$V_{OD} = 0V$ Driver outputs shorted	—	—	12	mA
T_R, T_F	Output rise and fall times, 20% to 80%	—	—	500	ps	T_R, T_F

Notes:

1. Data is for 3.5mA differential current drive. Other differential driver current options are available.
2. If the low power mode of the input buffer is used, the minimum V_{CM} is 600 mV.

Mini-LVDS**Over Recommended Operating Conditions**

Parameter Symbol	Description	Min.	Typ.	Max.	Units
Z_O	Single-ended PCB trace impedance	30	50	75	ohms
R_T	Differential termination resistance	60	100	150	ohms
V_{OD}	Output voltage, differential, $ V_{OP} - V_{OM} $	300	—	600	mV
V_{OS}	Output voltage, common mode, $ V_{OP} + V_{OM} /2$	1	1.2	1.4	V
ΔV_{OD}	Change in V_{OD} , between H and L	—	—	50	mV
ΔV_{ID}	Change in V_{OS} , between H and L	—	—	50	mV
V_{THD}	Input voltage, differential, $ V_{INP} - V_{INM} $	200	—	600	mV
V_{CM}	Input voltage, common mode, $ V_{INP} + V_{INM} /2$	$0.3+(V_{THD}/2)$	—	$2.1-(V_{THD}/2)$	
T_R, T_F	Output rise and fall times, 20% to 80%	—	—	500	ps
T_{ODUTY}	Output clock duty cycle	45	—	55	%
T_{IDUTY}	Input clock duty cycle	40	—	60	%

Note: Data is for 6mA differential current drive. Other differential driver current options are available.

RSDS**Over Recommended Operating Conditions**

Parameter Symbol	Description	Min.	Typ.	Max.	Units
V_{OD}	Output voltage, differential, $R_T = 100$ ohms	100	200	600	mV
V_{OS}	Output voltage, common mode	0.5	1.2	1.5	V
I_{RSDS}	Differential driver output current	1	2	6	mA
V_{THD}	Input voltage differential	100	—	—	mV
V_{CM}	Input common mode voltage	0.3	—	1.5	V
T_R, T_F	Output rise and fall times, 20% to 80%	—	500	—	ps
T_{ODUTY}	Output clock duty cycle	45	50	55	%

Note: Data is for 2mA drive. Other differential driver current options are available.

Differential HSTL and SSTL

Differential HSTL and SSTL outputs are implemented as a pair of complementary single-ended outputs. All allowable single-ended output classes (class I and class II) are supported in this mode.

MLVDS

The LatticeSC devices support the MLVDS standard. This industry standard is emulated using controlled impedance complementary LVCMOS outputs in conjunction with a parallel external resistor across the driver outputs. MLVDS is intended for use when multi-drop and bi-directional multi-point differential signaling is required. The scheme shown in Figure 3-1 is one possible solution for bi-directional multi-point differential signals.

Figure 3-1. MLVDS Multi-Point Output Example

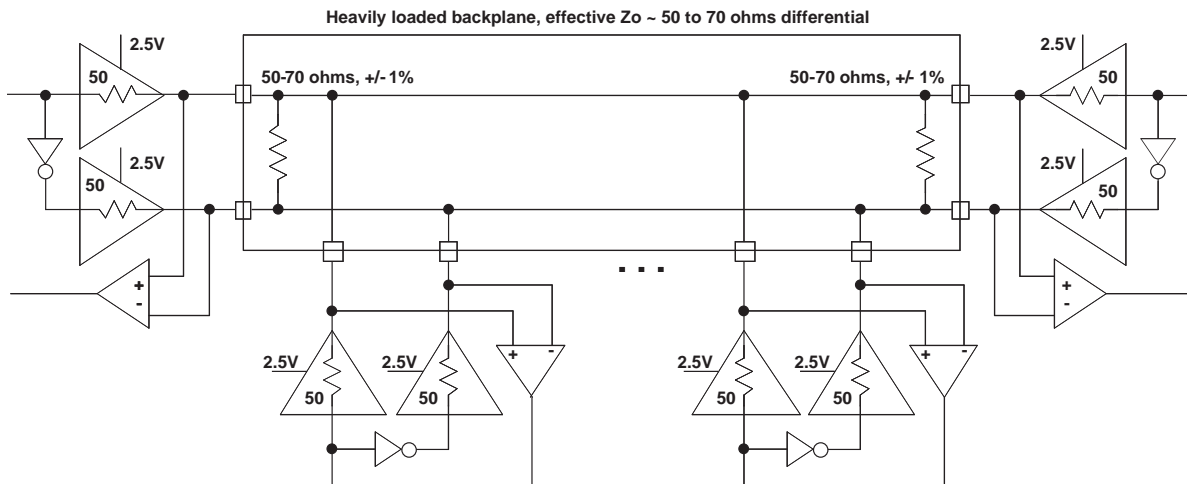

Table 3-1. MLVDS DC Conditions¹

Over Recommended Operating Conditions

Symbol	Description	Nominal		Units
		Zo = 50	Zo = 70	
Z _{OUT}	Output impedance	50	50	ohm
R _{TLEFT}	Left end termination	50	70	ohm
R _{TRIGHT}	Right end termination	50	70	ohm
V _{OH}	Output high voltage	1.50	1.575	V
V _{OL}	Output low voltage	1.00	0.925	V
V _{OD}	Output differential voltage	0.50	0.65	V
V _{CM}	Output common mode voltage	1.25	1.25	V
I _{DC}	DC output current	20.0	18.5	mA

1. For input buffer, see LVDS table.

BLVDS

The LatticeSC devices support BLVDS standard. This standard is emulated using controlled impedance complementary LVCMOS outputs in conjunction with a parallel external resistor across the driver outputs. BLVDS is intended for use when multi-drop and bi-directional multi-point differential signaling is required. The scheme shown in Figure 3-2 is one possible solution for bi-directional multi-point differential signals.

Figure 3-2. BLVDS Multi-point Output Example

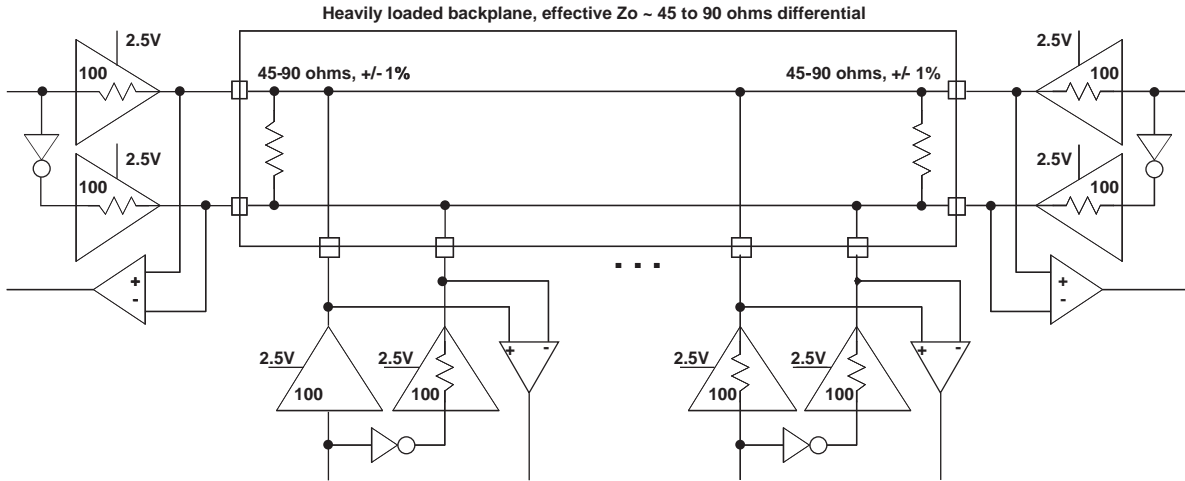

Table 3-2. BLVDS DC Conditions¹

Over Recommended Operating Conditions

Symbol	Description	Nominal		Units
		$Z_o = 45$	$Z_o = 90$	
Z_{OUT}	Output impedance	100	100	ohm
R_{TLEFT}	Left end termination	45	90	ohm
R_{TRIGHT}	Right end termination	45	90	ohm
V_{OH}	Output high voltage	1.375	1.48	V
V_{OL}	Output low voltage	1.125	1.02	V
V_{OD}	Output differential voltage	0.25	0.46	V
V_{CM}	Output common mode voltage	1.25	1.25	V
I_{DC}	DC output current	11.2	10.2	mA

1. For input buffer, see LVDS table.

LVPECL

The LatticeSC devices support differential LVPECL standard. This standard is emulated using controlled impedance complementary LVCMOS outputs in conjunction with a parallel resistor across the driver outputs. The scheme shown in Figure 3-3 is one possible solution for point-to-point signals.

Figure 3-3. Differential LVPECL

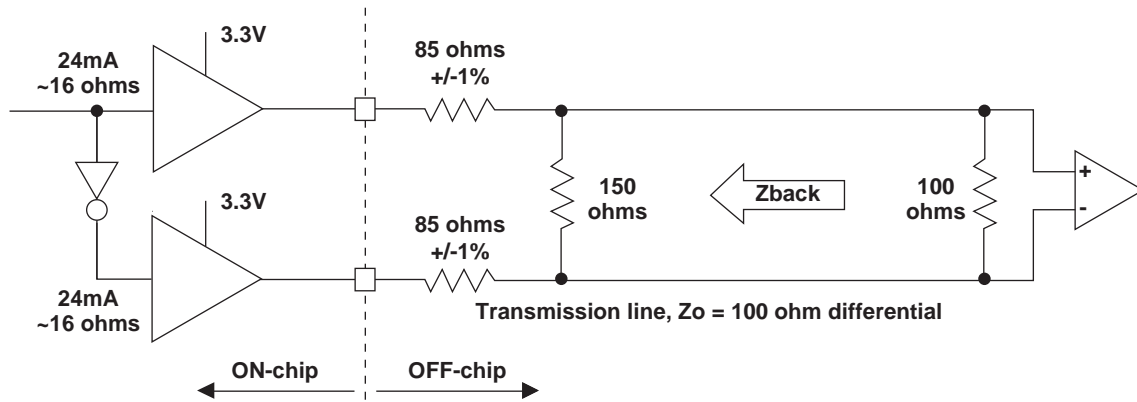

Table 3-3. LVPECL DC Conditions¹

Over Recommended Operating Conditions

Symbol	Description	Nominal	Units
Z_{OUT}	Output impedance	16	ohm
R_S	Driver series resistor	85	ohm
R_P	Driver parallel resistor	150	ohm
R_T	Receiver termination	100	ohm
V_{OH}	Output high voltage	2.03	V
V_{OL}	Output low voltage	1.27	V
V_{OD}	Output differential voltage	0.76	V
V_{CM}	Output common mode voltage	1.65	V
Z_{BACK}	Back impedance	86	ohm
I_{DC}	DC output current	12.6	mA

1. For input buffer, see LVDS table.

For further information on LVPECL, BLVDS, MLVDS and other differential interfaces please see details of additional technical documentation at the end of this data sheet.

On-die Differential Common Mode Termination

Symbol	Description	Min.	Typ.	Max.	Units
C_{CMT}	Capacitance V_{CMT} to GND	—	40	—	pF

Typical Building Block Function Performance

Over Recommended Commercial Operating Conditions at VCC = 1.2V +/- 5%

Pin to Pin Performance (LVCMOS25 12 mA Drive)

Function	-7*	Units
Basic Functions		
32-bit Decoder	6.65	ns
Combinatorial (Pin to LUT to Pin)	5.58	ns
Embedded Memory Functions (Single Port RAM)		
Pin to EBR Input Register Setup (Global Clock)	1.66	ns
EBR Output Clock to Pin (Global Clock)	8.54	ns
Distributed (PFU) RAM (Single Port RAM)		
Pin to PFU RAM Register Setup (Global Clock)	1.32	ns
PFU RAM Clock to Pin (Global Clock)	6.83	ns

*Typical performance per function

Register-to-Register Performance

Function	-7*	Units
Basic Functions		
32-Bit Decoder	539	MHz
64-Bit Decoder	517	MHz
16:1 MUX	1003	MHz
32:1 MUX	798	MHz
16-Bit Adder	672	MHz
64-Bit Adder	353	MHz
16-Bit Counter	719	MHz
64-Bit Counter	369	MHz
32x8 SP RAM (PFU, Output Registered)	768	MHz
128x8 SP RAM (PFU, Output Registered)	545	MHz
Embedded Memory Functions		
Single Port RAM (512x36 Bits)	372	MHz
True Dual Port RAM 1024x18 Bits (No EBR Out Reg)	326	MHz
True dual port RAM 1024x18 Bits (EBR Reg)	372	MHz
FIFO port (A: x36 bits, B: x9 Bits, No EBR Out Reg)	353	MHz
FIFO port (A: x36 bits, B: x9 Bits, EBR Reg)	375	MHz
True DP RAM Width Cascading (1024x72)	372	MHz
DSP Functions		
9x9 1-stage Multiplier	209	MHz
18x18 1-Stage Multiplier	155	MHz
9x9 3-Stage Pipelined Multiplier	373	MHz
18x18 4-Stage Pipelined Multiplier	314	MHz
9x9 Constant Multiplier	372	MHz

*Typical performance per function

Switching Characteristics

All devices are 100% functionally tested. Listed below are representative values of internal and external timing parameters. For more specific, more precise, and worst-case guaranteed data at a particular temperature and voltage, use the values reported by the static timing analyzer in the ispLEVER design tool from Lattice and back-annotate to the simulation net list.

LatticeSC/M External Switching Characteristics³

Over Recommended Commercial Operating Conditions at VCC = 1.2V +/- 5%

Parameter	Description	-7		-6		-5		Units
		Min.	Max.	Min.	Max.	Min.	Max.	
General I/O Pin Parameters (using Primary Clock without PLL)²								
t _{CO}	Global Clock Input to Output - PIO Output Register	2.83	5.74	2.83	6.11	2.83	6.49	ns
t _{SU}	Global Clock Input Setup - PIO Input Register without fixed input delay	-0.66	—	-0.66	—	-0.66	—	ns
t _H	Global Clock Input Hold - PIO Input Register without fixed input delay	1.73	—	1.95	—	2.16	—	ns
t _{SU_IDLY}	Global Clock Input Setup - PIO Input Register with input delay	0.86	—	1.03	—	1.20	—	ns
t _{H_IDLY}	Global Clock Input Hold - PIO Input Register with input delay	-0.17	—	-0.17	—	-0.17	—	ns
f _{MAX_PFU}	Global Clock frequency of PFU register	—	700	—	700	—	700	MHz
f _{MAX_IO}	Global Clock frequency of I/O register	—	1000	—	1000	—	1000	MHz
t _{GC_SKEW}	Global Clock skew	—	89	—	103	—	116	ps
General I/O Pin Parameters (using Primary Clock with PLL)^{1,2}								
t _{CO}	Global Clock Input to Output - PIO Output Register	2.25	4.81	2.25	5.08	2.25	5.37	ns
t _{SU}	Global Clock Input Setup - PIO Input Register without fixed input delay	-0.07	—	-0.07	—	-0.07	—	ns
t _H	Global Clock Input Hold - PIO Input Register without fixed input delay	0.80	—	0.93	—	1.04	—	ns
General I/O Pin Parameters (using Edge Clock without PLL)²								
t _{CO}	Edge Clock Input to Output - PIO Output Register	2.38	4.77	2.38	5.04	2.38	5.33	ns
t _{SU}	Edge Clock Input Setup - PIO Input Register without fixed input delay	-0.08	—	-0.08	—	-0.08	—	ns
t _H	Edge Clock Input Hold - PIO Input Register	0.49	—	0.58	—	0.66	—	ns
t _{SU_IDLY}	Edge Clock Input Setup - PIO Input Register with input delay	0.81	—	0.97	—	1.12	—	ns
t _{H_IDLY}	Edge Clock Input Hold - PIO Input Register with input delay	-0.34	—	-0.34	—	-0.34	—	ns
t _{EC_SKEW}	Edge Clock skew	—	28	—	32	—	36	ps
General I/O Pin Parameters (using Latch FF without PLL)²								
t _{SU}	Latch FF, Input Setup - PIO Input Register without fixed input delay	-0.14	—	-0.14	—	-0.14	—	ns
t _H	Latch FF, Input Hold - PIO Input Register without fixed input delay	0.58	—	0.68	—	0.77	—	ns
t _{SU_IDLY}	Latch FF, Input Setup - PIO Input Register with input delay	0.70	—	0.68	—	0.77	—	ns
t _{H_IDLY}	Latch FF, Input Hold - PIO Input Register with input delay	-0.30	—	-0.30	—	-0.30	—	ns

1. No PLL delay tuning (clock injection removal mode, system clock feedback).
 2. Using LVCMOS25 12mA I/O. Timing adders for other supported I/O technologies are specified in the LatticeSC Family Timing Adders table.
 3. Complete Timing Parameters for a user design are incorporated when running ispLEVER. This is a sampling of the key timing parameters. Timing specs are for non-AIL applications.

LatticeSC/M Family Timing Adders

Over Recommended Operating Conditions at VCC = 1.2V +/- 5%

Buffer Type	Description	-7		-6		-5		Units
		Min.	Max.	Min.	Max.	Min.	Max.	
Input Adjusters								
LVDS	LVDS	-0.031	-0.031	-0.011	-0.011	0.009	0.009	ns
RSDS	RSDS	-0.031	-0.031	-0.011	-0.011	0.009	0.009	ns
BLVDS25	BLVDS	-0.031	-0.031	-0.011	-0.011	0.009	0.009	ns
MLVDS25	MLVDS	-0.031	-0.031	-0.011	-0.011	0.009	0.009	ns
LVPECL33	LVPECL	-0.031	-0.031	-0.011	-0.011	0.009	0.009	ns
HSTL18_I	HSTL_18 class I	-0.013	-0.015	0.015	0.007	0.042	0.029	ns
HSTL18_II	HSTL_18 class II	-0.013	-0.015	0.015	0.007	0.042	0.029	ns
HSTL18_III	HSTL_18 class III	-0.016	-0.018	0.008	0.003	0.032	0.023	ns
HSTL18_IV	HSTL_18 class IV	-0.016	-0.018	0.008	0.003	0.032	0.023	ns
HSTL18D_I	Differential HSTL 18 class I	0.006	0.001	0.029	0.024	0.052	0.046	ns
HSTL18D_II	Differential HSTL 18 class II	0.006	0.001	0.029	0.024	0.052	0.046	ns
HSTL15_I	HSTL_15 class I	-0.005	-0.016	0.026	-0.001	0.057	0.014	ns
HSTL15_II	HSTL_15 class II	-0.005	-0.016	0.026	-0.001	0.057	0.014	ns
HSTL15_III	HSTL_15 class III	-0.013	-0.015	0.015	0.007	0.042	0.029	ns
HSTL15_IV	HSTL_15 class IV	-0.013	-0.015	0.015	0.007	0.042	0.029	ns
HSTL15D_I	Differential HSTL 15 class I	-0.021	-0.022	0.001	-0.009	0.022	0.003	ns
HSTL15D_II	Differential HSTL 15 class II	-0.021	-0.022	0.001	-0.009	0.022	0.003	ns
SSTL33_I	SSTL_3 class I	-0.036	-0.061	-0.181	-0.313	-0.326	-0.565	ns
SSTL33_II	SSTL_3 class II	-0.036	-0.061	-0.181	-0.313	-0.326	-0.565	ns
SSTL33D_I	Differential SSTL_3 class I	0.012	0.012	0.034	0.028	0.055	0.043	ns
SSTL33D_II	Differential SSTL_3 class II	0.012	0.012	0.034	0.028	0.055	0.043	ns
SSTL25_I	SSTL_2 class I	0.003	-0.008	0.03	0.011	0.058	0.03	ns
SSTL25_II	SSTL_2 class II	0.003	-0.008	0.03	0.011	0.058	0.03	ns
SSTL25D_I	Differential SSTL_2 class I	0.006	0	0.031	0.023	0.056	0.046	ns
SSTL25D_II	Differential SSTL_2 class II	0.006	0	0.031	0.023	0.056	0.046	ns
SSTL18_I	SSTL_18 class I	-0.013	-0.015	0.015	0.007	0.042	0.029	ns
SSTL18_II	SSTL_18 class II	-0.013	-0.015	0.015	0.007	0.042	0.029	ns
SSTL18D_I	Differential SSTL_18 class I	0.006	0.001	0.029	0.024	0.052	0.046	ns
SSTL18D_II	Differential SSTL_18 class II	0.006	0.001	0.029	0.024	0.052	0.046	ns
LVTTTL33	LVTTTL	0.034	0.034	-0.05	-0.05	-0.134	-0.134	ns
LVC MOS33	LVC MOS 3.3	0.034	0.034	-0.05	-0.05	-0.134	-0.134	ns
LVC MOS25	LVC MOS 2.5	0	0	0	0	0	0	ns
LVC MOS18	LVC MOS 1.8	-0.068	-0.068	-0.087	-0.087	-0.105	-0.105	ns
LVC MOS15	LVC MOS 1.5	-0.131	-0.131	-0.186	-0.186	-0.241	-0.241	ns
LVC MOS12	LVC MOS 1.2	-0.238	-0.238	-0.364	-0.364	-0.49	-0.49	ns
PCI33	PCI	0.034	0.034	-0.05	-0.05	-0.134	-0.134	ns
PCIX33	PCI-X 3.3	0.034	0.034	-0.05	-0.05	-0.134	-0.134	ns
PCIX15	PCI-X 1.5	-0.005	-0.016	0.026	-0.001	0.057	0.014	ns
AGP1X33	AGP-1X 3.3	0.034	0.034	-0.05	-0.05	-0.134	-0.134	ns
AGP2X33	AGP-2X	-0.036	-0.061	-0.181	-0.313	-0.326	-0.565	ns

LatticeSC/M Family Timing Adders (Continued)

Over Recommended Operating Conditions at VCC = 1.2V +/- 5%

Buffer Type	Description	-7		-6		-5		Units
		Min.	Max.	Min.	Max.	Min.	Max.	
GTLPLUS15	GTLPLUS15	-0.013	-0.017	0.012	0.004	0.037	0.024	ns
GTL12	GTL12	-0.063	-0.071	-0.007	-0.048	0.056	-0.032	ns
Output Adjusters								
LVDS	LVDS	0.708	0.854	0.856	1.021	1.005	1.189	ns
RSDS	RSDS	0.708	0.854	0.856	1.021	1.005	1.189	ns
BLVDS25	BLVDS	-0.129	0.05	-0.136	0.069	-0.136	0.083	ns
MLVDS25	MLVDS	-0.059	0.059	-0.057	0.096	-0.054	0.133	ns
LVPECL33	LVPECL	-0.334	-0.181	-0.325	-1.389	-0.315	-2.598	ns
HSTL18_I	HSTL_18 class I	0.132	0.209	0.153	0.24	0.175	0.272	ns
HSTL18_II	HSTL_18 class II	0.24	0.176	0.268	0.255	0.298	0.333	ns
HSTL18D_I	Differential HSTL 18 class I	0.132	0.209	0.153	0.24	0.175	0.272	ns
HSTL18D_II	Differential HSTL 18 class II	0.24	0.176	0.268	0.255	0.298	0.333	ns
HSTL15_I	HSTL_15 class I	0.096	0.172	0.112	0.198	0.129	0.224	ns
HSTL15_II	HSTL_15 class II	0.208	0.131	0.233	0.203	0.259	0.275	ns
HSTL15D_I	Differential HSTL 15 class I	0.096	0.172	0.112	0.198	0.129	0.224	ns
HSTL15D_II	Differential HSTL 15 class II	0.208	0.131	0.233	0.203	0.259	0.275	ns
SSTL33_I	SSTL_3 class I	0.133	0.177	0.11	0.166	0.088	0.154	ns
SSTL33_II	SSTL_3 class II	0.173	0.247	0.164	0.253	0.156	0.258	ns
SSTL33D_I	Differential SSTL_3 class I	0.133	0.177	0.11	0.166	0.088	0.154	ns
SSTL33D_II	Differential SSTL_3 class II	0.173	0.247	0.164	0.253	0.156	0.258	ns
SSTL25_I	SSTL_2 class I	0.215	0.125	0.239	0.228	0.264	0.331	ns
SSTL25_II	SSTL_2 class II	0.277	0.181	0.311	0.284	0.345	0.387	ns
SSTL25D_I	Differential SSTL_2 class I	0.215	0.125	0.239	0.228	0.264	0.331	ns
SSTL25D_II	Differential SSTL_2 class II	0.277	0.181	0.311	0.284	0.345	0.387	ns
SSTL18_I	SSTL_2 class I	0.16	0.081	0.179	0.173	0.199	0.265	ns
SSTL18_II	SSTL_2 class II	0.238	0.15	0.263	0.244	0.295	0.338	ns
SSTL18D_I	Differential SSTL_2 class I	0.16	0.081	0.179	0.173	0.199	0.265	ns
SSTL18D_II	Differential SSTL_2 class II	0.238	0.15	0.263	0.244	0.295	0.338	ns
LVTTTL33_8mA	LVTTTL 8mA drive	-0.346	-0.165	-0.496	-0.296	-0.646	-0.428	ns
LVTTTL33_16mA	LVTTTL 16mA drive	-0.11	-0.18	-0.218	-0.32	-0.325	-0.46	ns
LVTTTL33_24mA	LVTTTL 24mA drive	-0.012	-0.18	-0.099	-0.321	-0.185	-0.463	ns
LVC MOS33_8mA	LVC MOS 3.3 8mA drive	-0.346	-0.165	-0.496	-0.296	-0.646	-0.428	ns
LVC MOS33_16mA	LVC MOS 3.3 16mA drive	-0.11	-0.18	-0.218	-0.32	-0.325	-0.46	ns
LVC MOS33_24mA	LVC MOS 3.3 24mA drive	-0.012	-0.18	-0.099	-0.321	-0.185	-0.463	ns
LVC MOS25_4mA	LVC MOS 2.5 4mA drive	-0.174	0.004	-0.195	0.002	-0.215	0	ns
LVC MOS25_8mA	LVC MOS 2.5 8mA drive	0	0	0	0	0	0	ns
LVC MOS25_12mA	LVC MOS 2.5 12mA drive	0.094	-0.025	0.107	0.096	0.12	0.216	ns
LVC MOS25_16mA	LVC MOS 2.5 16mA drive	0.145	-0.054	0.162	0.063	0.181	0.179	ns
LVC MOS25_OD	LVC MOS 2.5 open drain	0.073	-0.125	0.081	-0.081	0.091	-0.09	ns
LVC MOS18_4mA	LVC MOS 1.8 4mA drive	-0.278	-0.099	-0.312	-0.115	-0.345	-0.131	ns
LVC MOS18_8mA	LVC MOS 1.8 8mA drive	-0.073	-0.078	-0.078	-0.084	-0.083	-0.089	ns

LatticeSC/M Family Timing Adders (Continued)

Over Recommended Operating Conditions at VCC = 1.2V +/- 5%

Buffer Type	Description	-7		-6		-5		Units
		Min.	Max.	Min.	Max.	Min.	Max.	
LVC MOS18_12mA	LVC MOS 1.8 12mA drive	0.024	-0.106	0.019	-0.004	0.016	0.099	ns
LVC MOS18_16mA	LVC MOS 1.8 16mA drive	0.074	-0.134	0.08	-0.022	0.088	0.089	ns
LVC MOS18_OD	LVC MOS 1.8 open drain	0.002	-0.206	0	-0.196	-0.002	-0.221	ns
LVC MOS15_4mA	LVC MOS 1.5 4mA drive	-0.344	-0.164	-0.379	-0.186	-0.412	-0.209	ns
LVC MOS15_8mA	LVC MOS 1.5 8mA drive	-0.125	-0.137	-0.145	-0.157	-0.164	-0.176	ns
LVC MOS15_12mA	LVC MOS 1.5 12mA drive	-0.027	-0.166	-0.043	-0.07	-0.059	0.026	ns
LVC MOS15_16mA	LVC MOS 1.5 16mA drive	0.025	-0.195	0.013	-0.089	0.003	0.017	ns
LVC MOS15_OD	LVC MOS 1.5 open drain	-0.047	-0.267	-0.067	-0.267	-0.087	-0.299	ns
LVC MOS12_2mA	LVC MOS 1.2 2mA drive	-0.473	-0.293	-0.505	-0.317	-0.537	-0.34	ns
LVC MOS12_4mA	LVC MOS 1.2 4mA drive	-0.218	-0.239	-0.25	-0.271	-0.28	-0.303	ns
LVC MOS12_8mA	LVC MOS 1.2 8mA drive	-0.109	-0.269	-0.143	-0.181	-0.176	-0.093	ns
LVC MOS12_12mA	LVC MOS 1.2 12mA drive	-0.054	-0.3	-0.085	-0.203	-0.114	-0.106	ns
LVC MOS12_OD	LVC MOS 1.2 open drain	-0.126	-0.371	-0.166	-0.398	-0.204	-0.43	ns
PCI33	PCI	-0.216	-0.791	-0.417	-1.263	-0.618	-1.735	ns
PCIX33	PCI-X 3.3	-0.216	-0.791	-0.417	-1.263	-0.618	-1.735	ns
PCIX15	PCI-X 1.5	0.208	0.227	0.233	0.312	0.259	0.398	ns
AGP1X33	AGP-1X 3.3	-0.216	-0.791	-0.417	-1.263	-0.618	-1.735	ns
AGP2X33	AGP-2X	-0.216	-0.791	-0.417	-1.263	-0.618	-1.735	ns

LatticeSC/M Internal Timing Parameters¹

Over Recommended Commercial Operating Conditions at VCC = 1.2V +/- 5%

Parameter	Symbol	Description	-7		-6		-5		Units
			Min.	Max.	Min.	Max.	Min.	Max.	
PFU Logic Mode Timing									
t _{LUT4_PFU}	CTOF_DEL	LUT4 delay (A to D inputs to F output)	—	0.045	—	0.050	—	0.054	ns
t _{LUT5_PFU}	MTOOFX_DEL	LUT5 delay (inputs to output)	—	0.152	—	0.172	—	0.192	ns
t _{LSR_PFU}	LSR_DEL	Set/Reset to output (asynchronous)	—	0.378	—	0.426	—	0.474	ns
t _{SUM_PFU}	M_SET	Clock to Mux (M0,M1) input setup time	0.113	—	0.131	—	0.148	—	ns
t _{HM_PFU}	M_HLD	Clock to Mux (M0,M1) input hold time	-0.041	—	-0.046	—	-0.052	—	ns
t _{SUD_PFU}	DIN_SET	Clock to D input setup time	0.072	—	0.083	—	0.094	—	ns
t _{HD_PFU}	DIN_HLD	Clock to D input hold time	-0.028	—	-0.032	—	-0.035	—	ns
t _{CK2Q_PFU}	REG_DEL	Clock to Q delay, D-type register configuration	—	0.224	—	0.252	—	0.279	ns
t _{LE2Q_PFU}	LTCH_DEL	Clock to Q delay latch configuration	—	0.294	—	0.331	—	0.367	ns
t _{LD2Q_PFU}	TLTCH_DEL	D to Q throughput delay when latch is enabled	—	0.300	—	0.338	—	0.376	ns
PFU Memory Mode Timing									
t _{CORAM_PFU}	CLKTOF_DEL	Clock to Output	—	0.575	—	0.649	—	0.724	ns
t _{SUDATA_PFU}	DIN_SET	Data Setup Time	-0.024	—	-0.026	—	-0.027	—	ns
t _{HDATA_PFU}	DIN_HLD	Data Hold Time	0.075	—	0.084	—	0.094	—	ns
t _{SUADDR_PFU}	WAD_SET	Address Setup Time	-0.176	—	-0.196	—	-0.215	—	ns
t _{HADDR_PFU}	WAD_HLD	Address Hold Time	0.110	—	0.124	—	0.138	—	ns
t _{SUWREN_PFU}	WE_SET	Write/Read Enable Setup Time	0.014	—	0.019	—	0.024	—	ns
t _{HWREN_PFU}	WE_HLD	Write/Read Enable Hold Time	0.078	—	0.086	—	0.094	—	ns
PIC Timing									
PIO Input/Output Buffer Timing									
t _{IN_PIO}	IN_DEL	Input Buffer Delay(LVCMOS25)	—	0.578	—	0.661	—	0.744	ns
t _{OUT_PIO}	DOPADI_DEL	Output Buffer Delay(LVCMOS25)	—	2.712	—	3.027	—	3.395	ns
t _{SUI_PIO}	DIN_SET	Input Register Setup Time (Data Before Clock)	0.277	—	0.312	—	0.348	—	ns
t _{HI_PIO}	DIN_HLD	Input Register Hold Time (Data after Clock)	-0.267	—	-0.306	—	-0.345	—	ns
t _{COO_PIO}	CK_DEL	Output Register Clock to Output Delay	—	0.513	—	0.571	—	0.639	ns
t _{SUCE_PIO}	CE_SET	Input Register Clock Enable Setup Time	—	0.000	—	0.000	—	0.000	ns
t _{HCE_PIO}	CE_HLD	Input Register Clock Enable Hold Time	—	0.129	—	0.145	—	0.161	ns
t _{SULSR_PIO}	LSR_SET	Set/Reset Setup Time	0.057	—	0.060	—	0.063	—	ns
t _{HLSR_PIO}	LSR_HLD	Set/Reset Hold Time	-0.151	—	-0.159	—	-0.169	—	ns
t _{LE2Q_PIO}	CK_DEL	Input Register Clock to Q delay latch configuration	—	0.335	—	0.372	—	0.410	ns
t _{LD2Q_PIO}	DIN_DEL	Input Register D to Q throughput delay when latch is enabled	—	0.578	—	0.647	—	0.717	ns

LatticeSC/M Internal Timing Parameters¹ (Continued)

Over Recommended Commercial Operating Conditions at VCC = 1.2V +/- 5%

Parameter	Symbol	Description	-7		-6		-5		Units
			Min.	Max.	Min.	Max.	Min.	Max.	
EBR Timing									
t _{CO_EBR}	CK_Q_DEL	Clock (Read) to output from Address or Data	—	1.900	—	2.116	—	2.335	ns
t _{COO_EBR}	CK_Q_DEL	Clock (Write) to output from EBR output Register	0.390	—	0.444	—	0.498	—	ns
t _{SUDATA_EBR}	D_CK_SET	Setup Data to EBR Memory (Write clk)	-0.173	—	-0.192	—	-0.210	—	ns
t _{HDATA_EBR}	D_CK_HLD	Hold Data to EBR Memory (Write clk)	0.276	—	0.305	—	0.335	—	ns
t _{SUADDR_EBR}	A_CK_SET	Setup Address to EBR Memory (Write clk)	-0.165	—	-0.182	—	-0.200	—	ns
t _{HADDR_EBR}	A_CK_HLD	Hold Address to EBR Memory (Write clk)	0.269	—	0.298	—	0.327	—	ns
t _{SUWREN_EBR}	CE_CK_SET	Setup Write/Read Enable to EBR Memory (Write/Read clk)	0.225	—	0.226	—	0.226	—	ns
t _{HWREN_EBR}	CE_CK_HLD	Hold Write/Read Enable to EBR Memory (write/read clk)	0.073	—	0.095	—	0.116	—	ns
t _{SUCE_EBR}	CS_CK_SET	Clock Enable Setup Time to EBR Output Register (Read clk)	0.261	—	0.269	—	0.276	—	ns
t _{HCE_EBR}	CS_CK_HLD	Clock Enable Hold Time to EBR Output Register (Read clk)	0.023	—	0.039	—	0.055	—	ns
t _{RSTO_EBR}	RESET_Q_DEL	Reset To Output Delay Time from EBR Output Register (asynchronous)	—	0.589	—	0.673	—	0.757	ns
Cycle Boosting Timing									
t _{DEL1}	DEL1	Cycle boosting delay 1 applies to PIO, PFU, EBR	—	0.480	—	0.524	—	0.570	ns
t _{DEL2}	DEL2	Cycle boosting delay 2 applies to PIO, PFU, EBR	—	0.922	—	1.005	—	1.090	ns
t _{DEL3}	DEL3	Cycle boosting delay 3 applies to PIO, PFU, EBR	—	1.366	—	1.488	—	1.612	ns

1. Complete timing parameters for a user design will be incorporated when running ispLEVER. This is a sampling of the key timing parameters.

Input Delay Block/AIL Timing

Parameter	Description	Min.	Typ.	Max.	Units
t_{FDEL}	Fine delay time	35	45	80	ps
t_{CDEL}	Coarse delay time	1120	1440	2560	ps
$j_{t_{AIL}}$	AIL jitter tolerance	$1 - ((N^1 * t_{FDEL}) / (\text{Clock Period}))$			UI

1. N = number of fine delays used in a particular AIL setting

GSR Timing

Parameter	Description	VCC	-7		-6		-5		Units
			Min.	Max.	Min.	Max.	Min.	Max.	
$t_{SYNC_GSR_MAX}$	Maximum operating frequency for synchronous GSR	1.14V	—	438	—	417	—	398	MHz
		0.95V	—	378	—	355	—	337	MHz
$t_{ASYNC_GSR_MPW}$	Minimum pulse width of asynchronous input	—	—	—	—	—	3.3	—	ns

Note: Synchronous GSR goes out of reset in two cycles from the clock edge where the setup time of the FF was met.

Internal System Bus Timing

Parameter	Description	-7		-6		-5		Units
		Min.	Max.	Min.	Max.	Min.	Max.	
t_{HCLK}	Maximum operating frequency for internal system bus HCLK.	—	200	—	200	—	200	MHz

Note: There is no minimum frequency. If HCLK is sourced from the embedded oscillator, the minimum frequency limitation of the oscillator/divider is about 0.3 MHz. Refer to the oscillator data for missing configuration modes.

Timing Diagrams

PFU Timing Diagrams

Figure 3-4. Slice Single/Dual Port Write Cycle Timing

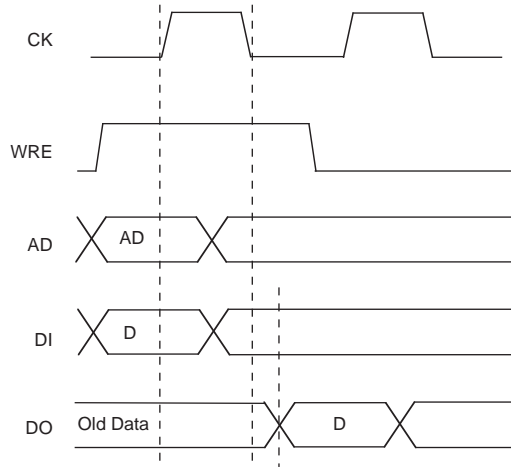

Notes:

- Rising Edge for latching WREN, WAD and DATAIN.
- WREN must continue past falling edge clock.
- Data output occurs on negative edge.

Figure 3-5. Slice Single/Dual Port Read Cycle Timing

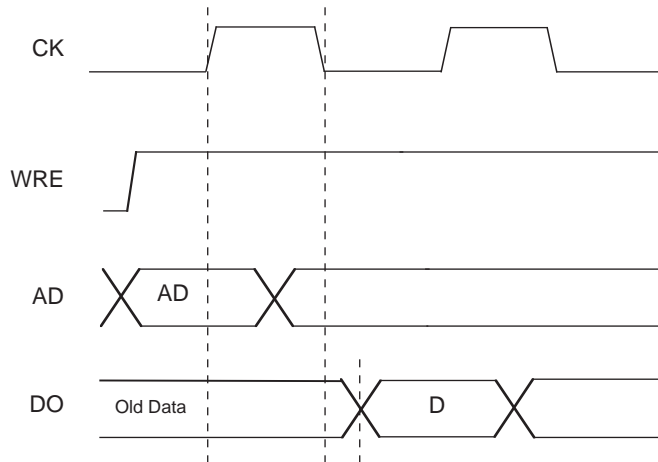

EBR Memory Timing Diagrams

Figure 3-6. Read Mode

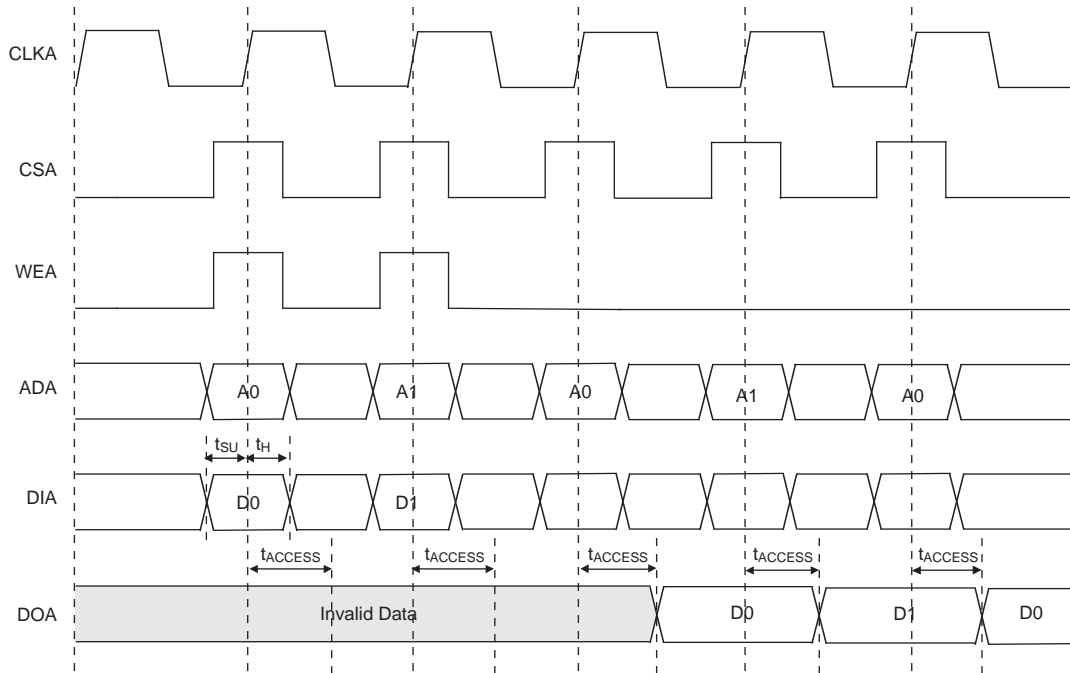

Note: Input data and address are registered at the positive edge of the clock and output data appears after the positive of the clock.

Figure 3-7. Read Mode with Input Registers Only

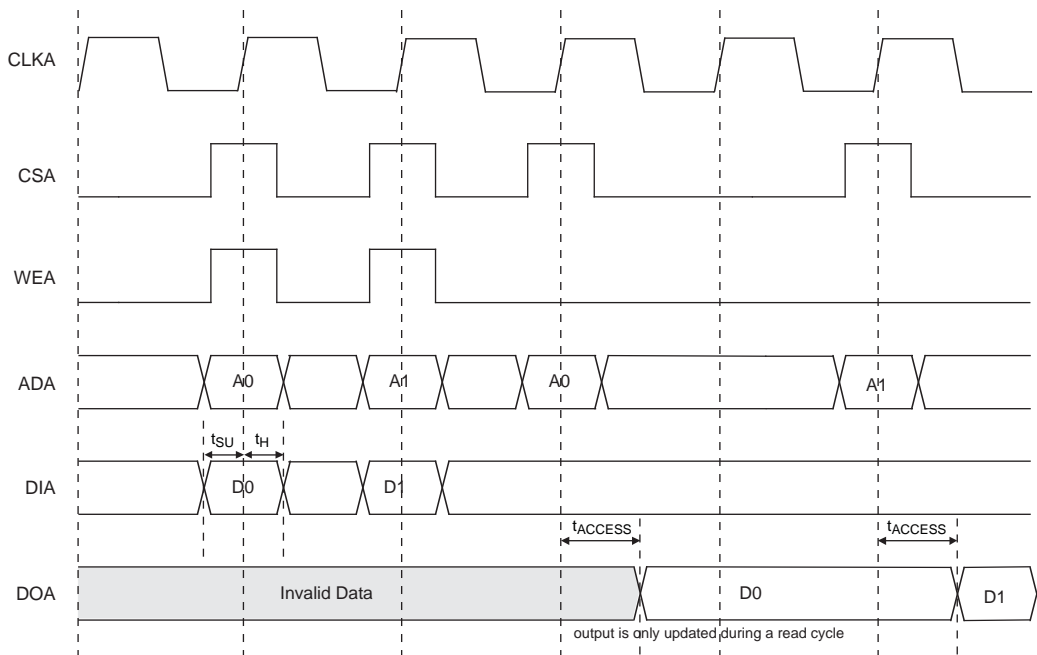

Figure 3-8. Read Mode with Input and Output Registers

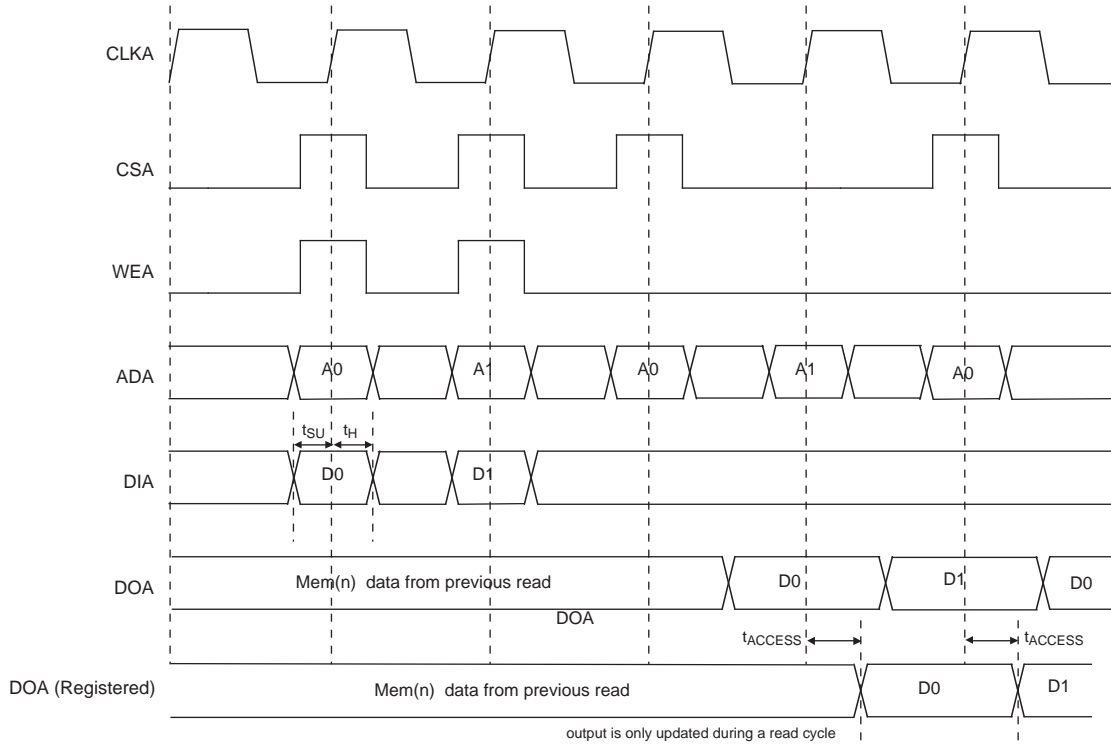
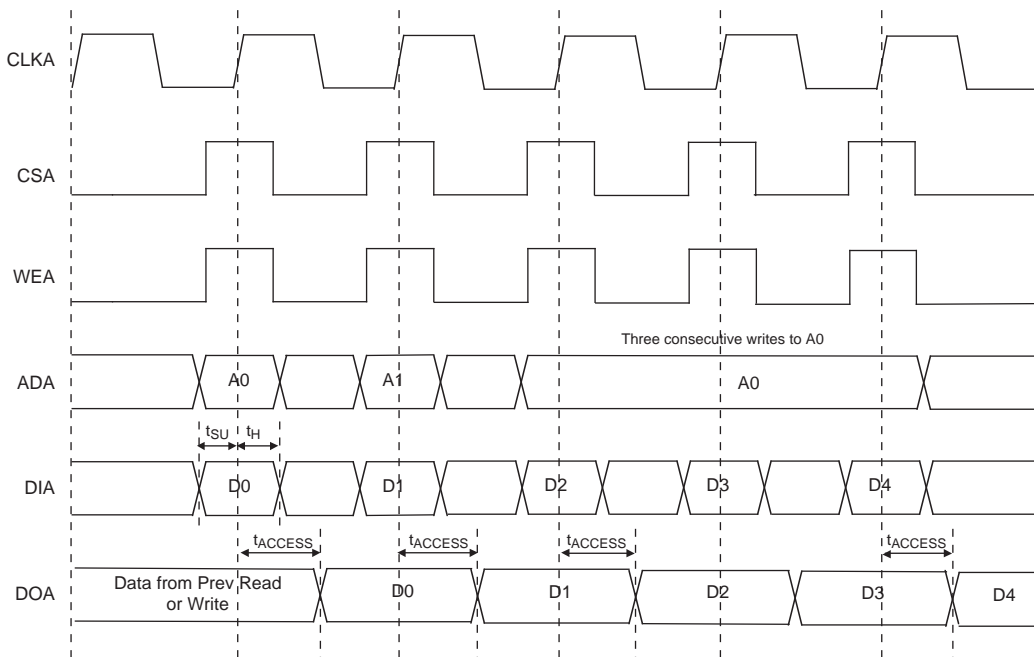
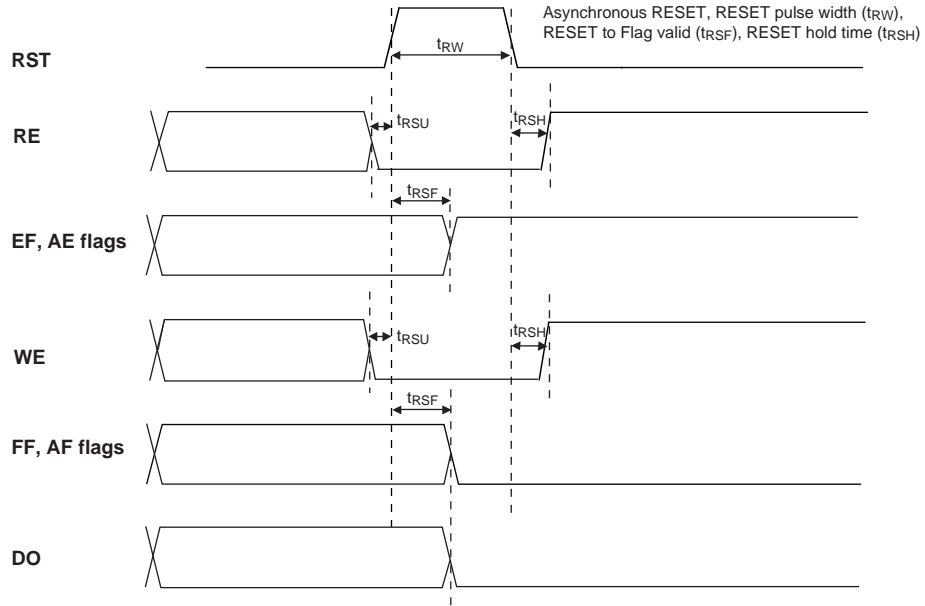

Figure 3-9. Write Through (SP Read/Write On Port A, Input Registers Only)



Note: Input data and address are registered at the positive edge of the clock and output data appears after the positive of the clock.

Figure 3-10. FIFO Reset Waveform



Note: RE and WE must be deactivated t_{RSU} before the Positive FIFO reset edge and enabled t_{RSH} after the FIFO reset negative edge.

Figure 3-11. Read Pointer Reset Waveform

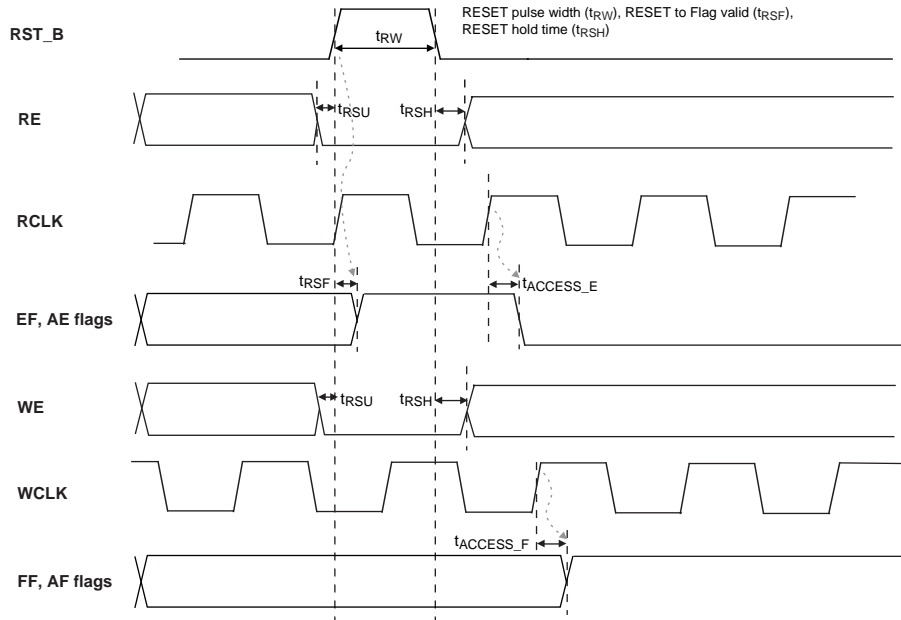

Note: RE and WE must be deactivated t_{RSU} before the Positive FIFO reset edge and enabled t_{RSH} after the FIFO reset negative edge.

Figure 3-12. Waveforms First Read after Full Flag

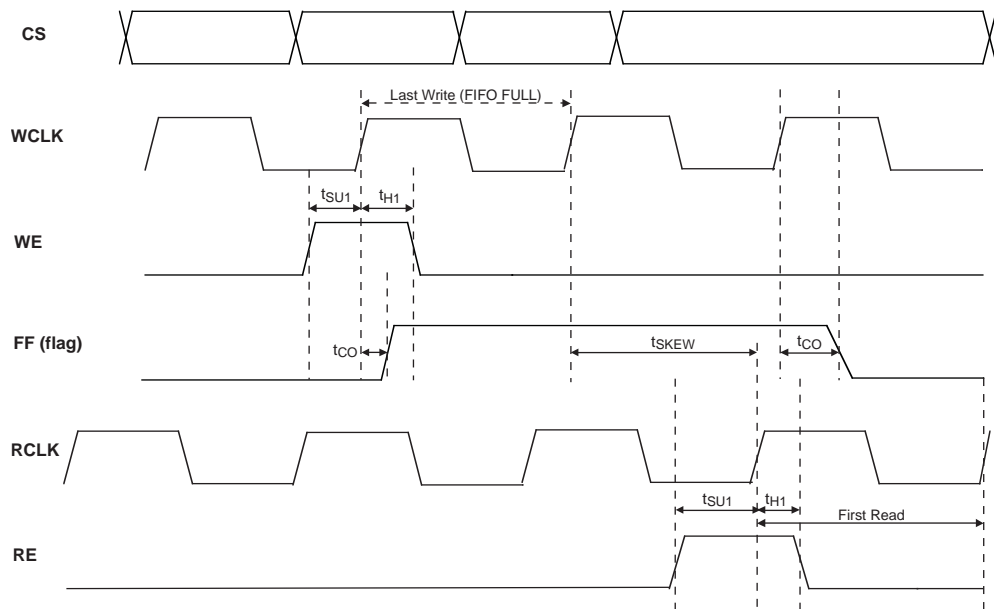
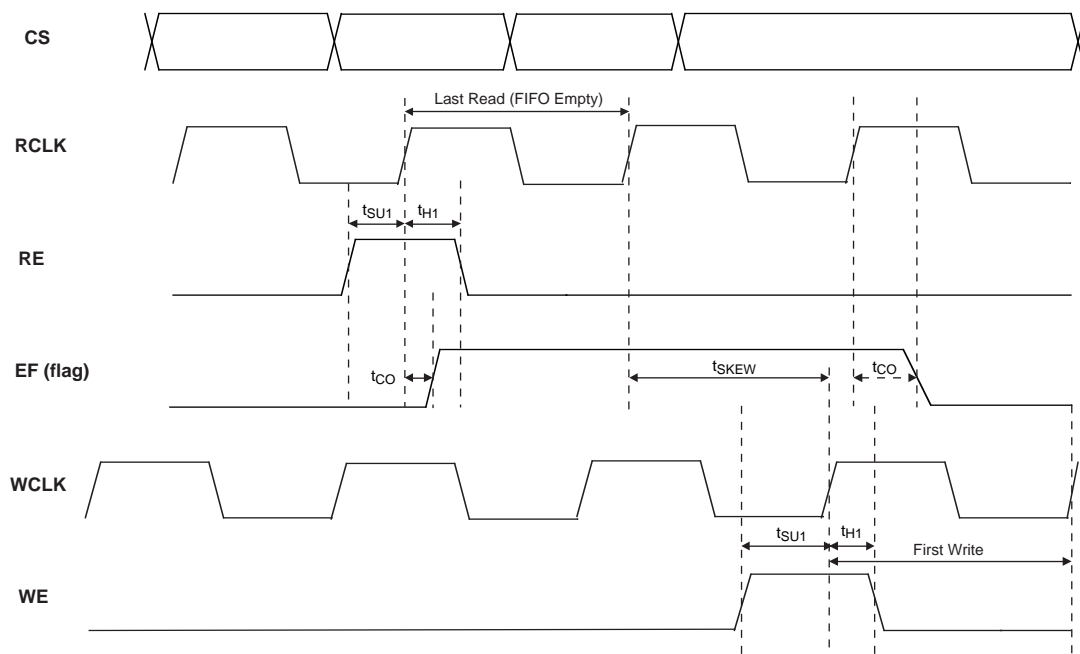

Figure 3-13. Waveform First Write after Empty Flag



sysCLOCK PLL Timing

Over Recommended Operating Conditions

Parameter	Description	Conditions	Min.	Typ	Max.	Units
f _{IN}	Input Clock Frequency (CLKI, CLKFB)		2	—	1000	MHz
f _{OUT}	Output Clock Frequency (CLKOP, CLKOS)		1.5625	—	1000	MHz
f _{VCO}	PLL VCO Frequency		100	—	1000	MHz
f _{PFD}	Phase Detector Input Frequency		2	—	700	MHz
AC Characteristics						
t _{DT}	Output Clock Duty Cycle	Default duty cycle selected (at 50% levels)	45	—	55	%
t _{OPJIT} ¹	Output Clock Period Jitter	2 MHz ≤ f _{PFD} ≤ 10 MHz	—	—	200	ps
		f _{PFD} > 10 MHz	—	—	100	ps
t _{CPJIT} ¹	Output Clock Cycle-to-Cycle Jitter		—	—	100	ps
t _{SKEW}	Output Clock-to-Clock Skew (Between Two Outputs with the Same Phase Setting)		—	—	20	ps
t _{LOCK}	PLL Lock-in Time		—	—	1	ms
t _{IPJIT}	Input Clock Period Jitter		—	—	±250	ps
t _{HI}	Input Clock High Time	At 80% level	350	—	—	ps
t _{LO}	Input Clock Low Time	At 20% level	350	—	—	ps
t _{RSWA}	Analog Reset Signal Pulse Width		100	—	—	ns
t _{RSWD}	Digital Reset Signal Pulse Width		3	—	—	ns
t _{DEL}	Timeshift Delay Step Size		40	80	120	ps
t _{RANGE}	Timeshift Delay Range		—	+/- 560	—	ps
f _{SS}	Spread Spectrum Modulation Frequency		30	—	500	KHz
% Spread	Percentage Downspread for SS Mode		0.5	—	1.5	%
	VCO Clock Phase Adjustment Accuracy		-5	—	5	°

1. Values are measured with FPGA logic active, no additional I/Os toggling and REFCLK total jitter = 30 ps

sysCLOCK DLL Timing**Over Recommended Operating Conditions**

Parameter	Description	Conditions	Min.	Typ.	Max.	Units
f_{IN}	Input Clock Frequency (CLKI, CLKFB)		100	—	700	MHz
f_{OUTOP}	Output Clock Frequency (CLKOP)		100	—	700	MHz
f_{OUTOS}	Output Clock Frequency (CLKOS)		25	—	700	MHz
AC Characteristics						
t_{DUTY}	Output Clock Duty Cycle	Output Clock Duty Cycle (at 50% levels, 50% duty cycle input clock, duty cycle correction turned off, time reference delay mode)	38	—	62	%
t_{DUTYRD}	Output Clock Duty Cycle	Output Clock Duty Cycle (at 50% levels, arbitrary duty cycle input clock, duty cycle correction turned on, time reference delay mode)	45	—	55	%
$t_{DUTYCIR}$	Output Clock Duty Cycle	Output Clock Duty Cycle (at 50% levels, arbitrary duty cycle input clock, duty cycle correction turned on, clock injection removal mode)	40	—	60	%
t_{OPJIT}^1	Output Clock Period Jitter		—	—	200	ps
t_{CPJIT}^1	Output Clock Cycle-to-Cycle Jitter		—	—	200	ps
t_{SKEW}	Output Clock to Clock Skew (Between Two Outputs with the Same Phase Setting)		—	—	100	ps
t_{LOCK}	DLL Lock-in Time		8	—	18500	cycles
t_{IDUTY}	Input Clock Duty Cycle	Applies to all operating conditions	35	—	65	%
t_{IPJIT}	Input Clock Period Jitter		—	—	+/- 250	ps
t_{HI}	Input Clock High Time	At 80% level	500	—	—	ps
t_{LO}	Input Clock Low Time	At 20% level	500	—	—	ps
t_{RSWD}	Reset Signal Pulse Width		3	—	—	ns
t_{FDEL}	Timeshift Delay Step Size		35	45	80	ps
t_{DLL}	Delay Through the DLL when No Delay Taps are Chosen but Not in Bypass Mode.		—	760	—	ps

1. Values are measured with FPGA logic active, no additional I/Os toggling and REFCLK total jitter = 30 ps.

LatticeSC/M sysCONFIG Port Timing

Over Recommended Operating Conditions

Parameter	Description	Min.	Max.	Units
General Configuration Timing				
t _S MODE	M[3:0] Setup Time to INITN High	0	—	ns
t _H MODE	M[3:0] Hold Time from INITN High	600	—	ns
t _{RW}	RESETN Pulse Width Low to Start Reconfiguration (1.2 V)	50 (or 100 at 0.95V)	—	ns
t _{PGW}	PROGRAMN Pulse Width Low to Start Reconfiguration (1.2 V)	50 (or 100 at 0.95V)	—	ns
f _{ESB_CLK_FRQ}	System Bus ESB_CLK Frequency (No Wait States)	—	133	MHz
sysCONFIG Master Parallel Configuration Mode				
t _S M	D[7:0] Setup Time to RCLK High	6	—	ns
t _H M	D[7:0] Hold Time to RCLK High	0	—	ns
t _{CL} M	RCLK Low Time (Non-compressed Bitstreams)	0.5	0.5	CCLK periods
	RCLK Low Time (Compressed Bitstreams)	0.5	7.5	CCLK periods
t _{CH} M	RCLK High Time	0.5	0.5	CCLK periods
sysCONFIG SPI Port				
t _{CF} GX	INITN High to CSCK Low	—	80	ns
t _{CS} SPI	INITN High to CSSPIN Low	0	2	μs
t _S CK	CSCK Low before CSSPIN Low	0	—	ns
t _{SO} CDO	CSCK Low to Output Valid	—	15	ns
t _{CS} PID	CSSPIN Low to CSCK high Setup Time	—	15	ns
f _{MA} XSPI	Max CCLK Frequency - SPI Flash Fast Read Opcode (0x0B) (SPIFASTN=0)	—	50	MHz
t _{SU} SPI	SOSPI/D0 Data Setup Time Before CSCK	7	—	ns
t _H SPI	SOSPI/D0 Data Hold Time After CSCK	2	—	ns
	Master Clock Frequency	Selected value - 30%	Selected value + 30%	MHz
	Duty Cycle	40	60	%
sysCONFIG Master Serial Configuration Mode				
t _S M	DIN Setup Time	4.4	—	ns
t _H M	DIN Hold Time	0	—	ns
f _C M	CCLK Frequency (No Divider)	90	190	MHz
f _{C_DIV}	CCLK Frequency (Div 128)	0.70	1.48	MHz
t _D	CCLK to DOUT Delay	—	7.5	ns
sysCONFIG Master Parallel Configuration Mode				
t _{AV} M	RCLK to Address Valid	—	10	ns
t _S M	D[7:0] Setup Time to RCLK High	6	—	ns
t _H M	D[7:0] Hold Time to RCLK High	0	—	ns
t _{CL} M	RCLK Low Time (Non-compressed Bitstream)	7.5	7.5	CCLK periods
	RCLK Low Time (Compressed Bitstream)	0.5	63.5	CCLK periods
t _{CH} M	RCLK High Time	0.5	0.5	CCLK periods
t _D M	CCLK to DOUT	—	7.5	ns

LatticeSC/M sysCONFIG Port Timing (Continued)

Over Recommended Operating Conditions

Parameter	Description	Min.	Max.	Units
sysCONFIG Asynchronous Peripheral Configuration Mode				
t_{WRAP}	WRN, CS0N and CS1 Pulse Width	5	-	ns
t_{SAP}	D[7:0] Setup Time	1.5	-	ns
t_{RDYAP}	RDY Delay	—	8	ns
t_{BAP}	RDY Low	1	8	CCLK periods
t_{WR2AP}	Earliest WRN After RDY Goes High	0	—	ns
t_{DENAP}	RDN to D[7:0] Enable/Disable	—	7.5	ns
t_{DAP}	CCLK to DOUT	—	7.5	ns
sysCONFIG Slave Serial Configuration Mode				
t_{SSS}	DIN Setup Time	5.2	—	ns
t_{HSS}	DIN Hold Time	0	—	ns
t_{CHSS}	CCLK High Time	3.75	—	ns
t_{CLSS}	CCLK Low Time	3.75	—	ns
f_{CSS}	CCLK Frequency	—	150	MHz
t_{DSS}	CCLK to DOUT	—	7.5	ns
sysCONFIG Slave Parallel Configuration Mode				
t_{S1SP}	CS0N, CS1, WRN Setup Time	5.2	—	ns
t_{H1SP}	CS0N, CS1, WRN Hold Time	0	—	ns
t_{S2SP}	D[7:0] Setup Time	5.2	—	ns
t_{H2SP}	D[7:0] Hold Time	0	—	ns
t_{CHSP}	CCLK High Time	3.75	—	ns
t_{CL}	CCLK Low Time	3.75	—	ns
f_{CSP}	CCLK Frequency	—	150	MHz

sysCONFIG MPI Port

Parameter	Description	-7		-6		-5		Units
		Min.	Max.	Min.	Max.	Min.	Max.	
$t_{MPICTRL_SET}$	MPI Control (MPCSTRBN, MPCWRN, MPCCLK, etc.) to MPCCLK Setup Time	4.9	—	5.2	—	5.5	—	ns
t_{MPIADR_SET}	MPI Address to MPCCLK Setup Time	3.9	—	4.2	—	4.5	—	ns
t_{MPIDAT_SET}	MPI Write Data to MPCCLK Setup Time	4.9	—	5.2	—	5.5	—	ns
$t_{MPIDPAR_SET}$	MPI Write Parity Data to MPCCLK Setup Time	3.9	—	4.2	—	4.5	—	ns
t_{MPI_HLD}	All Hold Times	0	—	0	—	0	—	ns
$t_{MPICTRL_DEL}$	MPCCLK to MPI Control (MPCTA, MPC-TEA, MPCRETRY)	—	5.6	—	6.7	—	8.7	ns
t_{MPIDAT_DEL}	MPCCLK to MPI Data	—	5.6	—	6.7	—	8.7	ns
$t_{MPIDPAR_DEL}$	MPCCLK to MPI Parity Data	—	4.9	—	5.7	—	7.7	ns
$f_{MPI_CLK_FRQ}$	MPCCLK Frequency	—	100	—	83	—	66	MHz

JTAG Port Timing Specifications

Over Recommended Operating Conditions

Symbol	Parameter	Min.	Max.	Units
f_{MAX}		—	25	MHz
t_{BTCP}	TCK [BSCAN] Clock Pulse Width	40	—	ns
t_{BTCPH}	TCK [BSCAN] Clock Pulse Width High	20	—	ns
t_{BTCPL}	TCK [BSCAN] Clock Pulse Width Low	20	—	ns
t_{BTS}	TCK [BSCAN] Setup Time	8	—	ns
t_{BTH}	TCK [BSCAN] Hold Time	10	—	ns
t_{BTRF}	TCK [BSCAN] Rise/Fall Time	50	—	mV/ns
t_{BTCO}	TAP Controller Falling Edge of Clock to Valid Output	—	10	ns
$t_{BTCODIS}$	TAP Controller Falling Edge of Clock to Valid Disable	—	10	ns
t_{BTCOEN}	TAP Controller Falling Edge of Clock to Valid Enable	—	10	ns
t_{BTCRS}	BSCAN Test Capture Register Setup Time	8	—	ns
t_{BTCRH}	BSCAN Test Capture Register Hold Time	10	—	ns
t_{BUTCO}	BSCAN Test Update Register, Falling Edge of Clock to Valid Output	—	25	ns
$t_{BTUODIS}$	BSCAN Test Update Register, Falling Edge of Clock to Valid Disable	—	25	ns
$t_{BTUPOEN}$	BSCAN Test Update Register, Falling Edge of Clock to Valid Enable	—	25	ns

Figure 3-14. JTAG Port Timing Waveforms

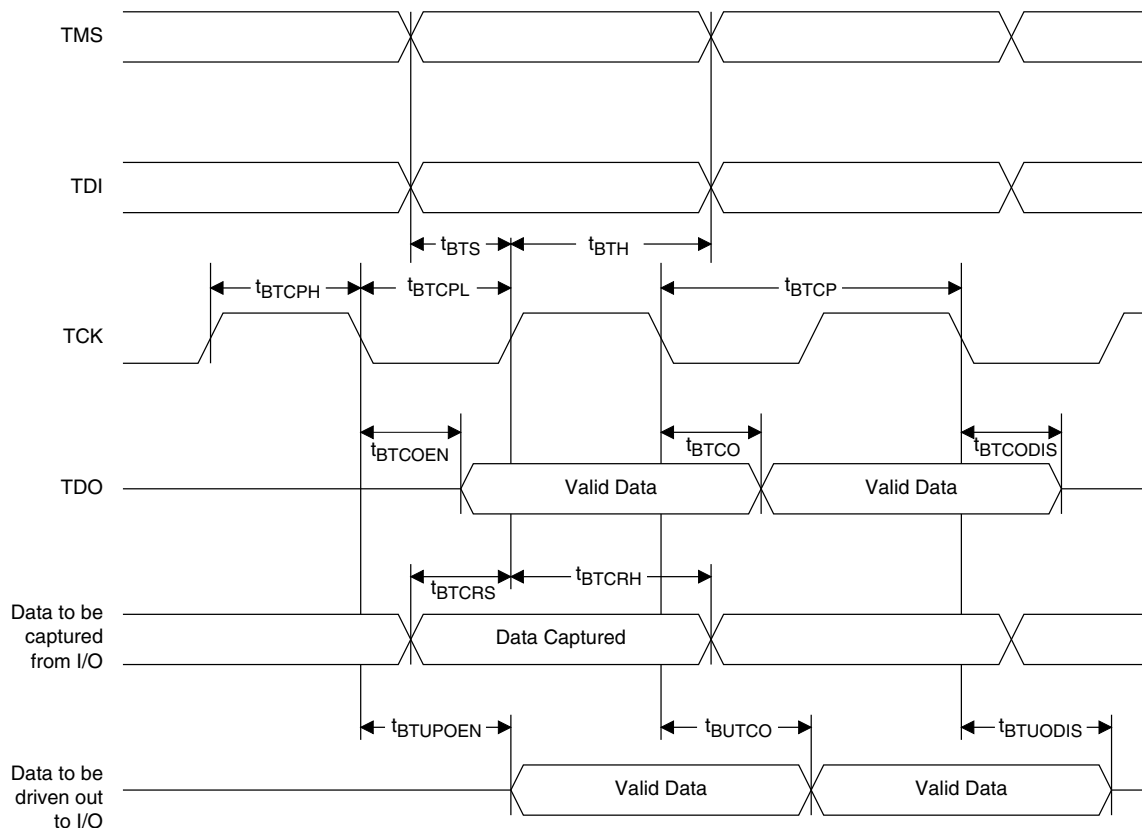

Switching Test Conditions

Figure 3-15 shows the output test load that is used for AC testing. The specific values for resistance, capacitance, voltage, and other test conditions are shown in Table 3-4.

Figure 3-15. Output Test Load, LVTTTL and LVCMOS Standards

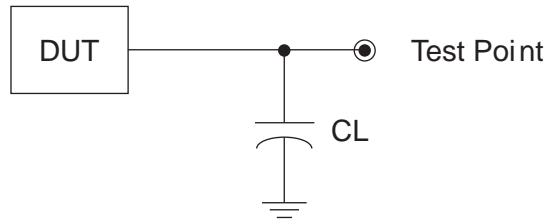

Table 3-4. Test Fixture Required Components, Non-Terminated Interfaces

Test Condition	C _L	Timing Ref.	V _T
LVTTTL and other LVCMOS settings (L -> H, H -> L)	30pF	LVCMOS 3.3 = 1.5V	—
		LVCMOS 2.5 = V _{CCIO} /2	—
		LVCMOS 1.8 = V _{CCIO} /2	—
		LVCMOS 1.5 = V _{CCIO} /2	—
		LVCMOS 1.2 = V _{CCIO} /2	—
LVCMOS 2.5 I/O (Z -> H)	30pF	V _{CCIO} /2	V _{OL}
LVCMOS 2.5 I/O (Z -> L)		V _{CCIO} /2	V _{OH}
LVCMOS 2.5 I/O (H -> Z)		V _{OH} - 0.15	V _{OL}
LVCMOS 2.5 I/O (L -> Z)		V _{OL} + 0.15	V _{OH}

Note: Output test conditions for all other interfaces are determined by the respective standards.

Signal Descriptions

Signal Name	I/O	Description
General Purpose		
P[Edge] [Row/Column Number*]_[A/B/C/D]	I/O	<p>[Edge] indicates the edge of the device on which the pad is located. Valid edge designations are L (Left), B (Bottom), R (Right), T (Top).</p> <p>[Row/Column Number] indicates the PIC row or the column of the device on which the PIC exists. When Edge is T (Top) or (Bottom), only need to specify Row Number. When Edge is L (Left) or R (Right), only need to specify Column Number.</p> <p>[A/B/C/D] indicates the PIO within the PIC to which the pad is connected.</p> <p>Some of these user programmable pins are shared with special function pins. These pin when not used as special purpose pins can be programmed as I/Os for user logic.</p> <p>During configuration the user-programmable I/Os are tri-stated with an internal pull-up resistor enabled. If any pin is not used (or not bonded to a package pin), it is also tri-stated with an internal pull-up resistor enabled after configuration.</p>
VREF1_x, VREF2_x	—	The reference supply pins for I/O bank x. Any I/O pin in a bank can be assigned as a reference supply pin, but software defaults use designated pin.
NC	—	No connect. NC pins should not be connected to any active signals, VCC or GND.
Non-SERDES Power Supplies		
VCCIOx	—	VCCIO - The power supply pins for I/O bank x. Dedicated pins.
VCC12 ¹	—	1.2V supply for configuration logic, PLLs and SERDES Rx, Tx and PLL. All VCC12 pins must be connected. As VCC12 supplies power for analog circuitry, VCC12 should be quiet and isolated from noisy digital board supplies.
VTT_x	—	Termination voltage for bank x. When VTT termination is not required, or used to provide the common mode termination voltage (VCMT), these pins can be left unconnected on the device. VCMT function is not used in the bank. If the internal or external VCMT function for differential input termination is used, the VTT pins should be unconnected and allowed to float.
GND	—	GND - Ground. Dedicated pins. All grounds must be electrically connected at the board level.
VCC	—	VCC - The power supply pins for core logic. Dedicated pins (1.2V/1.0V).
VCCAUX	—	VCCAUX - Auxiliary power supply pin - powers all differential and referenced input buffers. Dedicated pins (2.5V).
VCCJ	—	VCCJ - The power supply pin for JTAG Test Access Port.
PROBE_VCC	—	VCC signal - Connected to internal VCC node. Can be used for feedback to control an external board power converter. Can be unconnected if not used.

© 2008 Lattice Semiconductor Corp. All Lattice trademarks, registered trademarks, patents, and disclaimers are as listed at www.latticesemi.com/legal. All other brand or product names are trademarks or registered trademarks of their respective holders. The specifications and information herein are subject to change without notice.

Signal Descriptions (Cont.)

Signal Name	I/O	Description
PROBE_GND	—	GND signal - Connected to internal VSS node. Can be used for feedback to control an external board power converter. Can be unconnected if not used.
PLL and Clock Functions (Used as user-programmable I/O pins when not in use for PLL, DLL or clock pins.)		
[LOC]_PLL[T, C]_FB_[A/B]	I	PLL feedback input. Pull-ups are enabled on input pins during configuration. [LOC] indicates the corner the PLL is located in: ULC (upper left), URC (upper right), LLC (lower left) and LRC (lower right). [T, C] indicates whether input is true or complement. [A, B] indicates PLL reference within the corner.
[LOC]_DLL[T, C]_FB_[C, D, E, F]	I	DLL feedback input. Pull-ups are enabled on input pins during configuration. [LOC] indicates the corner the DLL is located in: ULC (upper left), URC (upper right), LLC (lower left) and LRC (lower right). [T/C] indicates whether input is true or complement. [C, D, E, F] indicates DLL reference within a corner. Note: E and F are only available on the lower corners.
[LOC]_PLL[T, C]_IN[A/B]	I	PLL reference clock input. Pull-ups are enabled on input pins during configuration. [LOC] indicates the corner the PLL is located in: ULC (upper left corner), URC (upper right corner), LLC (lower left corner) and LRC (lower right corner). [T, C] indicates whether input is true or complement. [A, B] indicates PLL reference within the corner.
[LOC]_DLL[T, C]_IN[C, D, E, F]		DLL reference clock inputs. Pull-ups are enabled on input pins during configuration. [LOC] indicates the corner the DLL is located in: ULC (upper left corner), URC (upper right corner), LLC (lower left corner) and LRC (lower right corner). [T/C] indicates whether input is true or complement. [C, D, E, F] indicates DLL reference within a corner. Note: E and F are only available on the lower corners. PCKLxy_[0:3] can drive primary clocks, edge clocks, and CLKDIVs. PCKLxy_[4:7] can only drive edge clocks.
PCKLxy_z		General clock inputs. x indicates whether T (true) or C (complement). y indicates the I/O bank the clock is associated with. z indicates the clock number within a bank.
Test and Programming (Dedicated pins. Pull-up is enabled on input pins during configuration.)		
TMS	I	Test Mode Select input, used to control the 1149.1 state machine.
TCK	I	Test Clock input pin, used to clock the 1149.1 state machine.
TDI	I	Test Data in pin, used to load data into device using 1149.1 state machine. After power-up, this TAP port can be activated for configuration by sending appropriate command. (Note: once a configuration port is selected it is locked. Another configuration port cannot be selected until the power-up sequence).
TDO	O	Output pin -Test Data out pin used to shift data out of device using 1149.1.
Configuration Pads (Dedicated pins. Used during sysCONFIG.)		
M[3:0]	I	Mode pins used to specify configuration modes values latched on rising edge of INITN.
INITN	I/O	Open Drain pin - Indicates the FPGA is ready to be configured. During configuration, a pull-up is enabled that will pull the I/O above 1.5V.
PROGRAMN	I	Initiates configuration sequence when asserted low. This pin always has an active pull-up.
DONE	I/O	Open Drain pin - Indicates that the configuration sequence is complete, and the startup sequence is in progress.
CCLK	I/O	Configuration Clock for configuring an FPGA in sysCONFIG mode.

Signal Descriptions (Cont.)

Signal Name	I/O	Description
RESETN		Reset. (Also sent to general routing). During configuration it resets the configuration state machine. After configuration this pin can perform the global set/reset (GSR) functions or can be used as a general input pin.
CFGIRQN	O	MPI Interrupt request active low signal is controlled by system bus interrupt controller and may be sourced from any bus error or MPI configuration error. It can be connected to one of MPC860 IRQ pins.
TSALLN	I	Tristates all I/O.
Configuration Pads (User I/O if not used. Used during sysCONFIG.)		
HDC/SI	O	High During Configuration is output high until configuration is complete. It is used as a control output, indicating that configuration is not complete. For SPI modes, this pin is used to download the read command and initial read address into the Flash memory device on the falling edge of SCK. This pin will be connected to SI of the memory. If the SPI mode is used, the 8-bit instruction code 0x03 will be downloaded followed by a 24-bit starting address of 0x000000 or a non-zero stat address for partial reconfiguration. If the SPIX mode has been selected, the 8-bit instruction captured on D[7:0] at power-up will be shifted in and followed by a 32-bit starting address of 0x000000.
LDCN/SCS	O	Low During Configuration is output low until configuration is complete. It is used as a control output, indicating that configuration is not complete. For SPI modes, this is an active low chip select for Flash memories. It will go active after INITN goes high but before SCK begins. During power up LDCN will be low. Once INITN goes high, LDCN will go high for 100ns-200ns after which time it will go back low and configuration can begin. During the 100ns-200ns period, the read instruction will be latched for SPIX mode.
DOUT	O	Serial data output that can drive the D0/DIN of daisy-chained slave devices. The data-stream from this output will propagate preamble bits of the bitstream to daisy-chained devices. Data out on DOUT changes on the rising edge of CCLK.
QOUT/CEON	O	During daisy-chaining configuration, QOUT is the serial data output that can drive the D0/DIN of daisy-chained slave devices that do not propagate preamble bits. Data out on QOUT changes on the rising edge of CCLK. During parallel-chaining configuration, active low CEON enables the cascaded slave device to receive bitstream data.
RDN	I	Used in the asynchronous peripheral configuration mode. A low on RDN changes D[7:3] into status outputs. WRN and RDN should not be used simultaneously. If they are, the write strobe overrides.
WRN	I	When the FPGA is selected, a low on the write strobe, WRN, loads the data on D[7:0] inputs into an internal data buffer.
CS0N CS1	I	Used in the asynchronous peripheral, slave parallel and MPI modes. The FPGA is selected when CS0N is low and CS1 is high. During configuration, a pull-up is enabled on both except with MPI DMA access control.
A[21:0]	I/O	In master parallel mode, A[21:0] is an output and will address the configuration EPROMs up to 4 MB space. For MPI configuration mode, A[17:0] will be the MPI address MPL_ADDR[31:14], A[19:18] will be the transfer size and A[21:20] will be the burst mode and burst in process.

Signal Descriptions (Cont.)

Signal Name	I/O	Description
D[n:0]	I/O	In parallel configuration modes, D[7:0] receives configuration data, and each pin is pull-up enabled. For slave serial mode, D0 is the data input. D[7:3] is the output internal status for peripheral mode when RDN is low. D[7:0] is also the first byte of MPI data pins. In MPI configuration mode, MPI selectable data bus width from 8 and 16-bit. Driven by a bus master in a write transaction. Driven by MPI in a read transaction.
DP[m:0]	I/O	MPI selectable parity data bus width from 1, 2, and 3-bit DP[0] for D[7:0], DP[1] for D[15:8], and DP[2] for D[23:16].
BUSYN/RCLK/SCK	O	During configuration in peripheral mode, high on BUSYN indicates another byte can be written to the FPGA. If a read operation is done when the device is selected, the same status is also available on D[7] in asynchronous peripheral mode. During configuration in slave parallel mode, low on BUSYN inhibits the external host from sending new data. The output is used by slave parallel and master serial modes only for decompression. During configuration in master parallel and master byte modes, RCLK is a read clock output signal to an external memory. The RCLK frequency is the same as CCLK when used with uncompressed bit-streams. RCLK will be 1/8 the frequency of CCLK when the bitstream is compressed. During configuration in SPI modes, SCK is generated by the device and connected to the CLK input of the FLASH memory.
MPI Interface (Dedicated pin)		
MPI_IRQ_N	O	MPI Interrupt request active low signal is controlled by system bus interrupt controller and may be sourced from any bus error or MPI configuration error. It can be connected to one of MPC860 IRQ pins.
MPI Interface (User I/O if MPI is not used.)		
MPI_CS0N MPI_CS1	I	MPI chip select pins, active low on MPI_CS0N while active high on MPI_CS1. Both have to be active during the whole transfer data phase. During transfer address phase, both can be inactive so that the decoding for them from address can be slow. If they are active during address phase, one cycle can be saved for sync read.
MPI_CLK	I	This is the PowerPC bus clock. It can be a source of the clock for embedded system bus. If MPI_CLK is used as system bus clock, MPI will be set into sync mode by default. All of the operation on PowerPC side of MPI are synchronized to the rising edge of this clock.
MPI_TSIZE[1:0]	I	Driven by a bus master to indicate the data transfer size for the transaction. 01 for byte, 10 for half-word, and 00 for word.
MPI_WR_N	I	Driven high indicates that a read access is in progress. Driven low indicates that a write access is in process.
MPI_BURST	I	Driven active low indicates that a burst transfer is in progress. Driven high indicates that the current transfer is not a burst.
MPI_BDIP	I	Active low "Burst Data in Process" is driven by a PowerPC processor. Asserted indicates that the second beat in front of the current one is requested by the master. Negated before the burst transfer ends to abort the burst data phase.

Signal Descriptions (Cont.)

Signal Name	I/O	Description
MPI_STRBN	I	Driven active low indicates the start of a transaction on the PowerPC bus. MPI will strobe the address bus at next rising edge of clock.
MPI_ADDR[31:14]	I	Address bus driven by a PowerPC bus master. Only 18-bit width is needed. It has to be the least significant bit of the PowerPC 32-bit address A[31:14].
MPI_DAT[n:0]	I/O	Selectable data bus width from 8, and 16-bit. Driven by a bus master in a write transaction. Driven by MPI in a read transaction.
MPI_PAR[m:0]	I/O	Selectable parity bus width from 1, 2, and 3-bit. MPI_DP[0] for MPI_D[7:0], MPI_DP[1] for MPI_D[15:8] and MPI_DP[2] for MPI_D[23:16].
MPI_TA	O	Transfer acknowledge. Driven active low indicates that MPI received the data on the write cycle or returned data on the read cycle.
MPI_TEA	O	Transfer Error Acknowledge. Driven active low indicates that MPI detects a bus error on the internal system bus for current transaction.
MPI_RETRY	O	Active low MPI Retry requests the MPC860 to relinquish the bus and retry the cycle.
Multi-chip Alignment (User I/O if not used.)		
MCA_DONE_OUT	O	Multi-chip alignment done output (to second MCA chip)
MCA_DONE_IN	I	Multi-chip alignment done input (from second MCA chip)
MCA_CLK_P[1:2]_OUT	O	Multi-chip alignment clock [1:2] output (sourced by MCA master chip)
MCA_CLK_P[1:2]_IN	I	Multi-chip alignment clock [1:2] input (from MCA master chip)
TEMP	—	Temperature sensing diode pin. Dedicated pin. Accuracy is typically +/- 10°C.
Miscellaneous Dedicated Pins		
XRES	—	External reference resistor between this pin and ground. The reference resistor is used to calibrate the programmable terminating resistors used in the I/Os. Dedicated pin. Value: 1K ± 1% ohm.
DIFFRx	—	Only used if a differential driver is used in a bank. This DIFFRx must be connected to ground via an external 1K ±1% ohm resistor for all banks that have a differential driver.
SERDES Block (Dedicated Pins)		
[A:D]_HDINPx_[L/R]	I	High-speed input (positive) channel x on left [L] or right [R] side of device. PCS quad is defined in the dual function name column of the Logic Signal Connection table.
[A:D]_HDINNx_[L/R]	I	High-speed input (negative) channel x on left [L] or right [R] side of device. PCS quad is defined in the dual function name column of the Logic Signal Connection table.
[A:D]_HDOUTPx_[L/R]	O	High-speed output (positive) channel x on left [L] or right [R] side of device. PCS quad is defined in the dual function name column of the Logic Signal Connection table.
[A:D]_HDOUTNx_[L/R]	O	High-speed output (negative) channel x on left [L] or right [R] side of device. PCS quad is defined in the dual function name column of the Logic Signal Connection table.
[A:D]_REFCLKP_[L/R]	I	Ref clock input (positive), aux channel on left [L] or right [R] side of device.
[A:D]_REFCLKN_[L/R]	I	Ref clock input (negative), aux channel on left [L] or right [R] side of device.

Signal Descriptions (Cont.)

Signal Name	I/O	Description
RESP_[ULC/URC]	—	Calibration resistor to be placed between this pin and either ground or RESPN_[ULC/URC]. RESPN_[ULC/URC] is available on select packages. If available, connection of calibration resistor between RESP_[ULC/URC] and RESPN_[ULC/URC] takes precedence over connection of calibration resistor between RESP_[ULC/URC] and ground. Note: only one per side of the device. Value: 4.02K ohm +/- 1% ohm.
RESPN_[ULC/URC]	—	Available on selected packages. If available, calibration resistor should be placed between RESP_[ULC/URC] and RESPN_[ULC/URC] instead of between RESP_[ULC/URC] and ground. Note: only one per side of the device. Value: 4.02K ohm +/- 1% ohm.
[A:D]_VDDIBx_[L/R]	—	Input buffer power supply for channel x (1.2V/1.5V) on left [L] or right [R] side of device.
[A:D]_VDDOBx_[L/R]	—	Output buffer power supply for channel x (1.2V/1.5V) on left [L] or right [R] side of device.
[A:D]_VDDAX25_[L/R]	—	Auxiliary power for input and output termination (2.5V) on left [L] or right [R] side of device.

1. The ispLEVER software tools may specify VDDR_X, VD_{DTX}, VD_{DP} and VCCL pins. These pins should be considered VCC12 pins.
Note: Signals listed as Signal A / Signal B define the same physical pin that is used for different functions based on configuration mode.

Pin Information Summary

Pin Type		256 fpBGA	900 fpBGA		1020 fcBGA	
		LFSC/M15	LFSC/M15	LFSC/M25	LFSC/M25	LFSC/M40
Single Ended User I/O		139	300	378	476	562
Differential Pair User I/O		60	141	182	235	277
LVDS Output Pairs		22	44	60	60	78
Configuration	Dedicated	9	11	11	11	11
	Muxes/MPI sysBus	0	55	55	55	72
JTAG (excluding VCCJ)		4	4	4	4	4
Dedicated Pins		2	4	4	4	4
VCC		10	46	46	40	40
VCC12		10	35	35	36	36
VCCAUX		10	36	36	32	32
VCCIO	Bank 1	3	18	18	10	10
	Bank 2	2	14	14	8	8
	Bank 3	2	15	15	10	10
	Bank 4	3	15	15	10	10
	Bank 5	3	15	15	10	10
	Bank 6	2	15	15	10	10
	Bank 7	2	16	16	8	8
VTT	Bank 2	0	2	2	2	2
	Bank 3	0	3	3	3	3
	Bank 4	0	3	3	3	3
	Bank 5	0	3	3	3	3
	Bank 6	0	3	3	3	3
	Bank 7	0	2	2	2	2
GND		26	177	177	134	134
NC		0	102	24	92	6
Single Ended User / Differential I/O per Bank	Bank 1	21/8	63/30	63/30	68/32	68/32
	Bank 2	15/7	26/13	30/15	34/17	54/27
	Bank 3	19/8	43/20	62/29	84/42	94/47
	Bank 4	25/11	50/22	66/32	84/41	99/48
	Bank 5	25/11	49/23	65/32	88/44	99/49
	Bank 6	19/8	43/20	62/29	84/42	94/47
	Bank 7	15/7	26/13	30/15	34/17	54/27
LVDS Output Pairs Per Bank	Bank 2	5	7	9	9	15
	Bank 3	6	15	21	21	24
	Bank 6	6	15	21	21	24
	Bank 7	5	7	9	9	15
VCCJ		1	1	1	1	1
SERDES (signal + power supply)		28	60	60	108	108
Total		256	900	900	1020	1152

Pin Information Summary (Cont.)

Pin Type		1152 fcBGA			1704 fcBGA	
		LFSC/M40	LFSC/M80	LFSC/M115	LFSC/M80	LFSC/M115
Single Ended User I/O		604	660	660	904	942
Differential Pair User I/O		302	330	330	452	470
LVDS Output Pairs		78	102	102	114	132
Configuration	Dedicated	11	11	11	11	11
	Muxes/MPI sysBus	72	72	72	72	72
JTAG (excluding VCCJ)		4	4	4	4	4
Dedicated Pins		4	4	4	4	4
VCC		44	44	44	76	76
VCC12		52	52	52	88	88
VCCAUX		38	38	38	52	52
VCCIO	Bank 1	10	10	10	10	10
	Bank 2	9	9	9	12	12
	Bank 3	12	12	12	14	14
	Bank 4	12	12	12	14	14
	Bank 5	12	12	12	14	14
	Bank 6	12	12	12	14	14
	Bank 7	9	9	9	12	12
VTT	Bank 2	3	3	3	4	4
	Bank 3	3	3	3	4	4
	Bank 4	3	3	3	5	5
	Bank 5	3	3	3	5	5
	Bank 6	3	3	3	4	4
	Bank 7	3	3	3	4	4
GND		130	130	130	184	184
NC		62	6	6	52	14
Single Ended User / Differential I/O per Bank	Bank 1	80/40	80/40	80/40	80/40	80/40
	Bank 2	60/30	76/38	76/38	96/48	103/51
	Bank 3	96/48	108/54	108/54	132/66	144/72
	Bank 4	106/53	106/53	106/53	184/92	184/92
	Bank 5	106/53	106/53	106/53	184/92	184/92
	Bank 6	96/48	108/54	108/54	132/66	144/72
	Bank 7	60/30	76/38	76/38	96/48	103/51
LVDS Output Pairs Per Bank	Bank 2	15	21	21	24	27
	Bank 3	24	30	30	33	39
	Bank 6	24	30	30	33	39
	Bank 7	15	21	21	24	27
VCCJ		1	1	1	1	1
SERDES (signal + power supply)		108	108	108	212	212
Total		1152	1152	1152	1704	1704

LFSC/M15 Logic Signal Connections: 256 fpBGA^{1,2}

Ball Number	LFSC/M15		
	Ball Function	VCCIO Bank	Dual Function
E4	A_VDDAX25_L	-	
B1	A_REFCLKP_L	-	
C1	A_REFCLKN_L	-	
D2	RESP_ULC	-	
F5	RESETN	1	
D1	DONE	1	
E1	INITN	1	
E2	M0	1	
E3	M1	1	
E5	M2	1	
E6	M3	1	
F2	PL15A	7	ULC_PLLT_IN_A/ULC_PLLT_FB_B
F1	PL15B	7	ULC_PLLC_IN_A/ULC_PLLC_FB_B
F3	PL17A	7	ULC_DLLT_IN_C/ULC_DLLT_FB_D
G1	PL17B	7	ULC_DLLC_IN_C/ULC_DLLC_FB_D
G4	PL18D	7	VREF2_7
H3	PL22A	7	
H2	PL22B	7	
H5	PL22C	7	VREF1_7
G5	PL22D	7	DIFFR_7
H1	PL23A	7	PCLKT7_1
J1	PL23B	7	PCLKC7_1
J2	PL24A	7	PCLKT7_0
J3	PL24B	7	PCLKC7_0
H4	PL24C	7	PCLKT7_2
H6	PL24D	7	PCLKC7_2
J4	PL26A	6	PCLKT6_0
K5	PL26B	6	PCLKC6_0
J5	PL26C	6	PCLKT6_1
J6	PL26D	6	PCLKC6_1
K1	PL28A	6	
L1	PL28B	6	
L4	PL28C	6	PCLKT6_2
K4	PL28D	6	PCLKC6_2
L2	PL31C	6	VREF1_6
L3	PL35A	6	
M3	PL35B	6	
M2	PL35D	6	DIFFR_6
M1	PL37A	6	
N1	PL37B	6	
P2	PL41D	6	VREF2_6
M5	PL43A	6	

LFSC/M15 Logic Signal Connections: 256 fpBGA^{1,2} (Cont.)

Ball Number	LFSC/M15		
	Ball Function	VCCIO Bank	Dual Function
M4	PL43B	6	
P1	PL45A	6	LLC_DLLT_IN_F/LLC_DLLT_FB_E
R1	PL45B	6	LLC_DLLC_IN_F/LLC_DLLC_FB_E
R2	XRES	-	
P3	TEMP	6	
R3	PB3A	5	LLC_PLLT_IN_A/LLC_PLLT_FB_B
N4	PB3B	5	LLC_PLLC_IN_A/LLC_PLLC_FB_B
T3	PB3C	5	LLC_DLLT_IN_C/LLC_DLLT_FB_D
T2	PB3D	5	LLC_DLLC_IN_C/LLC_DLLC_FB_D
N5	PB5D	5	VREF1_5
P5	PB8A	5	
R5	PB8B	5	
T4	PB9A	5	
T5	PB9B	5	
R6	PB12A	5	PCLKT5_3
T6	PB12B	5	PCLKC5_3
L5	PB13C	5	
P6	PB15A	5	PCLKT5_0
T7	PB15B	5	PCLKC5_0
M7	PB15D	5	VREF2_5
R8	PB16A	5	PCLKT5_1
T8	PB16B	5	PCLKC5_1
N7	PB17A	5	PCLKT5_2
N8	PB17B	5	PCLKC5_2
R9	PB20A	5	
T9	PB20B	5	
M8	PB21A	5	
M9	PB21B	5	
P8	PB24A	5	
P9	PB24B	5	
T10	PB28A	4	
R11	PB28B	4	
N9	PB31A	4	
N10	PB31B	4	
T11	PB32A	4	
R12	PB32B	4	
P11	PB35A	4	PCLKT4_2
M10	PB35B	4	PCLKC4_2
T12	PB36A	4	PCLKT4_1
P12	PB36B	4	PCLKC4_1
T13	PB37A	4	PCLKT4_0
T14	PB37B	4	PCLKC4_0
R15	PB37C	4	VREF2_4

LFSC/M15 Logic Signal Connections: 256 fpBGA^{1,2} (Cont.)

Ball Number	LFSC/M15		
	Ball Function	VCCIO Bank	Dual Function
N12	PB39C	4	
T15	PB40A	4	PCLKT4_3
R16	PB40B	4	PCLKC4_3
L12	PB43A	4	
M12	PB43B	4	
P16	PB44A	4	
N16	PB44B	4	
R14	PB47C	4	VREF1_4
P15	PB48A	4	LRC_DLLT_IN_C/LRC_DLLT_FB_D
M13	PB48B	4	LRC_DLLC_IN_C/LRC_DLLC_FB_D
N13	PB49A	4	LRC_PLLT_IN_A/LRC_PLLT_FB_B
P14	PB49B	4	LRC_PLLC_IN_A/LRC_PLLC_FB_B
M16	PR45B	3	LRC_DLLC_IN_F/LRC_DLLC_FB_E
L16	PR45A	3	LRC_DLLT_IN_F/LRC_DLLT_FB_E
M14	PR43B	3	
M15	PR43A	3	
K16	PR41D	3	VREF2_3
J16	PR37B	3	
H16	PR37A	3	
L13	PR35D	3	DIFFR_3
L14	PR35B	3	
L15	PR35A	3	
K12	PR31C	3	VREF1_3
J13	PR28D	3	PCLKC3_2
K13	PR28C	3	PCLKT3_2
H15	PR28B	3	
F16	PR28A	3	
J11	PR26D	3	PCLKC3_1
J12	PR26C	3	PCLKT3_1
J15	PR26B	3	PCLKC3_0
J14	PR26A	3	PCLKT3_0
E16	PR24D	2	PCLKC2_2
D16	PR24C	2	PCLKT2_2
H11	PR24B	2	PCLKC2_0
H12	PR24A	2	PCLKT2_0
H13	PR23B	2	PCLKC2_1
H14	PR23A	2	PCLKT2_1
G12	PR22D	2	DIFFR_2
G13	PR22C	2	VREF1_2
F8	PR22B	2	
F9	PR22A	2	
G16	PR18D	2	VREF2_2
F15	PR17B	2	URC_DLLC_IN_C/URC_DLLC_FB_D

LFSC/M15 Logic Signal Connections: 256 fpBGA^{1,2} (Cont.)

Ball Number	LFSC/M15		
	Ball Function	VCCIO Bank	Dual Function
F14	PR17A	2	URC_DLLT_IN_C/URC_DLLT_FB_D
E15	PR15B	2	URC_PLLC_IN_A/URC_PLLC_FB_B
E14	PR15A	2	URC_PLLT_IN_A/URC_PLLT_FB_B
D9	VCCJ	-	
C16	TDO	-	TDO
B15	TMS	-	
B16	TCK	-	
E13	TDI	-	
C14	PROGRAMN	1	
C15	CCLK	1	
A15	PT43D	1	HDC/SI
A14	PT43C	1	LDCN/SCS
B14	PT41A	1	CS1
E12	PT39B	1	CS0N
D13	PT39A	1	RDN
D12	PT37D	1	WRN
E10	PT37C	1	D7
C11	PT37B	1	D6
D10	PT37A	1	D5
A13	PT36D	1	D4
B12	PT36C	1	D3
A12	PT35B	1	D2
C12	PT35A	1	D1
A11	PT33B	1	D0
B11	PT33A	1	QOUT/CEON
E9	PT32D	1	VREF2_1
E8	PT32B	1	DOUT
D8	PT28C	1	BUSYN/RCLK/SCK
A10	PT27B	1	PCLKC1_0
C10	PT27A	1	PCLKT1_0
E7	PT21C	1	VREF1_1
C9	A_VDDIB3_L	-	
A9	A_HDINP3_L	-	PCS 360 CH 3 IN P
B9	A_HDINN3_L	-	PCS 360 CH 3 IN N
A8	A_HDOUDP3_L	-	PCS 360 CH 3 OUT P
B8	A_HDOUIN3_L	-	PCS 360 CH 3 OUT N
C8	A_VDDOB3_L	-	
B7	A_HDOUIN2_L	-	PCS 360 CH 2 OUT N
C7	A_VDDOB2_L	-	
A7	A_HDOUDP2_L	-	PCS 360 CH 2 OUT P
B6	A_HDINN2_L	-	PCS 360 CH 2 IN N
A6	A_HDINP2_L	-	PCS 360 CH 2 IN P
C6	A_VDDIB2_L	-	

LFSC/M15 Logic Signal Connections: 256 fpBGA^{1,2} (Cont.)

Ball Number	LFSC/M15		
	Ball Function	VCCIO Bank	Dual Function
C5	A_VDDIB1_L	-	
A5	A_HDINP1_L	-	PCS 360 CH 1 IN P
B5	A_HDINN1_L	-	PCS 360 CH 1 IN N
A4	A_HDOUTP1_L	-	PCS 360 CH 1 OUT P
B4	A_HDOUTN1_L	-	PCS 360 CH 1 OUT N
C4	A_VDDOB1_L	-	
B3	A_HDOUTN0_L	-	PCS 360 CH 0 OUT N
C3	A_VDDOB0_L	-	
A3	A_HDOUTP0_L	-	PCS 360 CH 0 OUT P
B2	A_HDINN0_L	-	PCS 360 CH 0 IN N
A2	A_HDINP0_L	-	PCS 360 CH 0 IN P
C2	A_VDDIB0_L	-	
A1	GND	-	
A16	GND	-	
B10	GND	-	
C13	GND	-	
D15	GND	-	
D3	GND	-	
E11	GND	-	
F13	GND	-	
G14	GND	-	
G2	GND	-	
G8	GND	-	
H10	GND	-	
J7	GND	-	
K15	GND	-	
K3	GND	-	
K9	GND	-	
M6	GND	-	
N11	GND	-	
N14	GND	-	
N2	GND	-	
P10	GND	-	
P4	GND	-	
R13	GND	-	
R7	GND	-	
G10	VCC	-	
G7	VCC	-	
G9	VCC	-	
H7	VCC	-	
H8	VCC	-	
H9	VCC	-	
J10	VCC	-	
J8	VCC	-	

LFSC/M15 Logic Signal Connections: 256 fpBGA^{1,2} (Cont.)

Ball Number	LFSC/M15		
	Ball Function	VCCIO Bank	Dual Function
J9	VCC	-	
K8	VCC	-	
F6	VCC12	-	
F11	VCC12	-	
L11	VCC12	-	
L6	VCC12	-	
K7	VCC12	-	
K10	VCC12	-	
F10	VCCAUX	-	
F7	VCCAUX	-	
T1	GND	-	
G11	VCCAUX	-	
K11	VCCAUX	-	
L10	VCCAUX	-	
L9	VCCAUX	-	
L7	VCCAUX	-	
L8	VCCAUX	-	
T16	GND	-	
G6	VCCAUX	-	
K6	VCCAUX	-	
B13	VCCIO1	-	
D11	VCCIO1	-	
D14	VCCIO1	-	
F12	VCCIO2	-	
G15	VCCIO2	-	
K14	VCCIO3	-	
N15	VCCIO3	-	
M11	VCCIO4	-	
P13	VCCIO4	-	
R10	VCCIO4	-	
N6	VCCIO5	-	
P7	VCCIO5	-	
R4	VCCIO5	-	
K2	VCCIO6	-	
N3	VCCIO6	-	
F4	VCCIO7	-	
G3	VCCIO7	-	
D4	VCC12	-	
D7	VCC12	-	
D5	VCC12	-	
D6	VCC12	-	

1. Differential pair grouping within a PIC is A (True) and B (Complement) and C (True) and D (Complement).
 2. The LatticeSC/M15 in a 256-pin package does not support an MPI interface.

LFSC/M15, LFSC/M25 Logic Signal Connections: 900 fpBGA^{1,2}

Ball Number	LFSC/M15			LFSC/M25		
	Ball Function	VCCIO Bank	Dual Function	Ball Function	VCCIO Bank	Dual Function
F7	A_VDDAX25_L	-		A_VDDAX25_L	-	
B1	A_REFCLKP_L	-		A_REFCLKP_L	-	
C1	A_REFCLKN_L	-		A_REFCLKN_L	-	
D5	VCC12	-		VCC12	-	
A2	RESP_ULC	-		RESP_ULC	-	
E5	VCC12	-		VCC12	-	
D4	VCC12	-		VCC12	-	
H5	RESETN	1		RESETN	1	
H6	TSALLN	1		TSALLN	1	
G6	DONE	1		DONE	1	
G5	INITN	1		INITN	1	
F5	M0	1		M0	1	
F6	M1	1		M1	1	
F4	M2	1		M2	1	
E4	M3	1		M3	1	
D3	PL15A	7	ULC_PLLT_IN_A/ULC_PLLT_FB_B	PL16A	7	ULC_PLLT_IN_A/ULC_PLLT_FB_B
D2	PL15B	7	ULC_PLLC_IN_A/ULC_PLLC_FB_B	PL16B	7	ULC_PLLC_IN_A/ULC_PLLC_FB_B
J6	PL15C	7		PL16C	7	
J5	PL15D	7		PL16D	7	
E3	PL17A	7	ULC_DLLT_IN_C/ULC_DLLT_FB_D	PL17A	7	ULC_DLLT_IN_C/ULC_DLLT_FB_D
E2	PL17B	7	ULC_DLLC_IN_C/ULC_DLLC_FB_D	PL17B	7	ULC_DLLC_IN_C/ULC_DLLC_FB_D
K4	PL17C	7	ULC_PLLT_IN_B/ULC_PLLT_FB_A	PL17C	7	ULC_PLLT_IN_B/ULC_PLLT_FB_A
J4	PL17D	7	ULC_PLLC_IN_B/ULC_PLLC_FB_A	PL17D	7	ULC_PLLC_IN_B/ULC_PLLC_FB_A
F3	PL18A	7	ULC_DLLT_IN_D/ULC_DLLT_FB_C	PL18A	7	ULC_DLLT_IN_D/ULC_DLLT_FB_C
G3	PL18B	7	ULC_DLLC_IN_D/ULC_DLLC_FB_C	PL18B	7	ULC_DLLC_IN_D/ULC_DLLC_FB_C
K5	PL18C	7		PL18C	7	
K6	PL18D	7	VREF2_7	PL18D	7	VREF2_7
F2	PL19A	7		PL22A	7	
F1	PL19B	7		PL22B	7	
E1	PL19C	7		PL22C	7	
D1	PL19D	7		PL22D	7	
K3	PL22A	7		PL25A	7	
L3	PL22B	7		PL25B	7	
L6	PL22C	7	VREF1_7	PL25C	7	VREF1_7
M6	PL22D	7	DIFFR_7	PL25D	7	DIFFR_7
J1	PL23A	7	PCLKT7_1	PL26A	7	PCLKT7_1
K1	PL23B	7	PCLKC7_1	PL26B	7	PCLKC7_1
L1	PL24A	7	PCLKT7_0	PL27A	7	PCLKT7_0
M1	PL24B	7	PCLKC7_0	PL27B	7	PCLKC7_0
P8	PL24C	7	PCLKT7_2	PL27C	7	PCLKT7_2
R8	PL24D	7	PCLKC7_2	PL27D	7	PCLKC7_2
N2	PL26A	6	PCLKT6_0	PL29A	6	PCLKT6_0
N1	PL26B	6	PCLKC6_0	PL29B	6	PCLKC6_0
R7	PL26C	6	PCLKT6_1	PL29C	6	PCLKT6_1
R6	PL26D	6	PCLKC6_1	PL29D	6	PCLKC6_1

LFSC/M15, LFSC/M25 Logic Signal Connections: 900 fpBGA^{1,2} (Cont.)

Ball Number	LFSC/M15			LFSC/M25		
	Ball Function	VCCIO Bank	Dual Function	Ball Function	VCCIO Bank	Dual Function
N3	PL27A	6		PL30A	6	
P3	PL27B	6		PL30B	6	
P4	PL27C	6	PCLKT6_3	PL30C	6	PCLKT6_3
P2	PL28A	6		PL31A	6	
R2	PL28B	6		PL31B	6	
T3	PL28C	6	PCLKT6_2	PL31C	6	PCLKT6_2
R3	PL28D	6	PCLKC6_2	PL31D	6	PCLKC6_2
P1	PL31A	6		PL34A	6	
R1	PL31B	6		PL34B	6	
R5	PL31C	6	VREF1_6	PL34C	6	VREF1_6
R4	PL31D	6		PL34D	6	
T2	PL32A	6		PL35A	6	
U2	PL32B	6		PL35B	6	
T1	PL33A	6		PL38A	6	
U1	PL33B	6		PL38B	6	
V1	PL35A	6		PL42A	6	
W1	PL35B	6		PL42B	6	
V6	PL35D	6	DIFFR_6	PL42D	6	DIFFR_6
V2	PL36A	6		PL43A	6	
W2	PL36B	6		PL43B	6	
Y1	PL37A	6		PL44A	6	
AA1	PL37B	6		PL44B	6	
AB1	PL39A	6		PL48A	6	
AC1	PL39B	6		PL48B	6	
Y5	PL40A	6		PL49A	6	
Y6	PL40B	6		PL49B	6	
AD2	PL41A	6		PL51A	6	
AE2	PL41B	6		PL51B	6	
AB5	PL41D	6	VREF2_6	PL51D	6	VREF2_6
AC3	PL43A	6		PL52A	6	
AD3	PL43B	6		PL52B	6	
AF1	PL44A	6		PL55A	6	
AG1	PL44B	6		PL55B	6	
AB6	PL44C	6	LLC_DLLT_IN_E/LLC_DLLT_FB_F	PL55C	6	LLC_DLLT_IN_E/LLC_DLLT_FB_F
AC5	PL44D	6	LLC_DLLC_IN_E/LLC_DLLC_FB_F	PL55D	6	LLC_DLLC_IN_E/LLC_DLLC_FB_F
AF2	PL45A	6	LLC_DLLT_IN_F/LLC_DLLT_FB_E	PL57A	6	LLC_DLLT_IN_F/LLC_DLLT_FB_E
AG2	PL45B	6	LLC_DLLC_IN_F/LLC_DLLC_FB_E	PL57B	6	LLC_DLLC_IN_F/LLC_DLLC_FB_E
AC6	PL45C	6	LLC_PLLT_IN_B/LLC_PLLT_FB_A	PL57C	6	LLC_PLLT_IN_B/LLC_PLLT_FB_A
AC7	PL45D	6	LLC_PLLC_IN_B/LLC_PLLC_FB_A	PL57D	6	LLC_PLLC_IN_B/LLC_PLLC_FB_A
AE4	XRES	-		XRES	-	
AG4	VCC12	-		VCC12	-	
AD5	TEMP	6		TEMP	6	
AF5	VCC12	-		VCC12	-	
AH1	PB3A	5	LLC_PLLT_IN_A/LLC_PLLT_FB_B	PB3A	5	LLC_PLLT_IN_A/LLC_PLLT_FB_B
AJ1	PB3B	5	LLC_PLLC_IN_A/LLC_PLLC_FB_B	PB3B	5	LLC_PLLC_IN_A/LLC_PLLC_FB_B

LFSC/M15, LFSC/M25 Logic Signal Connections: 900 fpBGA^{1,2} (Cont.)

Ball Number	LFSC/M15			LFSC/M25		
	Ball Function	VCCIO Bank	Dual Function	Ball Function	VCCIO Bank	Dual Function
AF4	PB3C	5	LLC_DLLT_IN_C/LLC_DLLT_FB_D	PB3C	5	LLC_DLLT_IN_C/LLC_DLLT_FB_D
AE5	PB3D	5	LLC_DLLC_IN_C/LLC_DLLC_FB_D	PB3D	5	LLC_DLLC_IN_C/LLC_DLLC_FB_D
AG3	PB4A	5	LLC_DLLT_IN_D/LLC_DLLT_FB_C	PB4A	5	LLC_DLLT_IN_D/LLC_DLLT_FB_C
AH2	PB4B	5	LLC_DLLC_IN_D/LLC_DLLC_FB_C	PB4B	5	LLC_DLLC_IN_D/LLC_DLLC_FB_C
AD6	PB4C	5		PB4C	5	
AJ2	PB5A	5		PB5A	5	
AK2	PB5B	5		PB5B	5	
AD7	PB5C	5		PB5C	5	
AD8	PB5D	5	VREF1_5	PB5D	5	VREF1_5
AH3	PB7A	5		PB11A	5	
AJ3	PB7B	5		PB11B	5	
AF9	PB7C	5		PB11C	5	
AE10	PB7D	5		PB11D	5	
AK3	PB8A	5		PB12A	5	
AJ4	PB8B	5		PB12B	5	
AE11	PB9A	5		PB13A	5	
AF10	PB9B	5		PB13B	5	
AK4	PB11A	5		PB16A	5	
AK5	PB11B	5		PB16B	5	
AH10	PB12A	5	PCLKT5_3	PB20A	5	PCLKT5_3
AH11	PB12B	5	PCLKC5_3	PB20B	5	PCLKC5_3
AF13	PB12C	5	PCLKT5_4	PB20C	5	PCLKT5_4
AE14	PB12D	5	PCLKC5_4	PB20D	5	PCLKC5_4
AK6	PB13A	5	PCLKT5_5	PB21A	5	PCLKT5_5
AK7	PB13B	5	PCLKC5_5	PB21B	5	PCLKC5_5
AF14	PB13C	5		PB21C	5	
AJ11	PB15A	5	PCLKT5_0	PB23A	5	PCLKT5_0
AJ12	PB15B	5	PCLKC5_0	PB23B	5	PCLKC5_0
AH13	PB15D	5	VREF2_5	PB23D	5	VREF2_5
AK8	PB16A	5	PCLKT5_1	PB24A	5	PCLKT5_1
AK9	PB16B	5	PCLKC5_1	PB24B	5	PCLKC5_1
AH14	PB17A	5	PCLKT5_2	PB25A	5	PCLKT5_2
AG14	PB17B	5	PCLKC5_2	PB25B	5	PCLKC5_2
AK10	PB19A	5		PB28A	5	
AK11	PB19B	5		PB28B	5	
AH15	PB20A	5		PB29A	5	
AG15	PB20B	5		PB29B	5	
AH12	PB21A	5		PB31A	5	
AJ13	PB21B	5		PB31B	5	
AD15	PB21C	5		PB31C	5	
AE15	PB21D	5		PB31D	5	
AK12	PB23A	5		PB32A	5	
AK13	PB23B	5		PB32B	5	
AJ14	PB24A	5		PB33A	5	
AJ15	PB24B	5		PB33B	5	

LFSC/M15, LFSC/M25 Logic Signal Connections: 900 fpBGA^{1,2} (Cont.)

Ball Number	LFSC/M15			LFSC/M25		
	Ball Function	VCCIO Bank	Dual Function	Ball Function	VCCIO Bank	Dual Function
AK14	PB25A	5		PB35A	5	
AK15	PB25B	5		PB35B	5	
AK16	PB27A	4		PB37A	4	
AK17	PB27B	4		PB37B	4	
AJ16	PB28A	4		PB38A	4	
AJ17	PB28B	4		PB38B	4	
AE16	PB28C	4		PB38C	4	
AH16	PB29A	4		PB39A	4	
AG16	PB29B	4		PB39B	4	
AK18	PB31A	4		PB41A	4	
AK19	PB31B	4		PB41B	4	
AH17	PB32A	4		PB42A	4	
AH18	PB32B	4		PB42B	4	
AG17	PB32D	4		PB42D	4	
AJ18	PB33A	4		PB43A	4	
AJ19	PB33B	4		PB43B	4	
AK20	PB35A	4	PCLKT4_2	PB46A	4	PCLKT4_2
AK21	PB35B	4	PCLKC4_2	PB46B	4	PCLKC4_2
AF18	PB36A	4	PCLKT4_1	PB47A	4	PCLKT4_1
AG18	PB36B	4	PCLKC4_1	PB47B	4	PCLKC4_1
AJ20	PB37A	4	PCLKT4_0	PB49A	4	PCLKT4_0
AJ21	PB37B	4	PCLKC4_0	PB49B	4	PCLKC4_0
AG19	PB37C	4	VREF2_4	PB49C	4	VREF2_4
AK22	PB39A	4	PCLKT4_5	PB51A	4	PCLKT4_5
AK23	PB39B	4	PCLKC4_5	PB51B	4	PCLKC4_5
AH19	PB39C	4		PB51C	4	
AK24	PB40A	4	PCLKT4_3	PB52A	4	PCLKT4_3
AK25	PB40B	4	PCLKC4_3	PB52B	4	PCLKC4_3
AE19	PB40C	4	PCLKT4_4	PB52C	4	PCLKT4_4
AE20	PB40D	4	PCLKC4_4	PB52D	4	PCLKC4_4
AE21	PB41A	4		PB53A	4	
AF21	PB41B	4		PB53B	4	
AG21	PB43A	4		PB55A	4	
AG22	PB43B	4		PB55B	4	
AH22	PB44A	4		PB56A	4	
AH23	PB44B	4		PB56B	4	
AH21	PB44C	4		PB56C	4	
AK28	PB45A	4		PB60A	4	
AK29	PB45B	4		PB60B	4	
AE22	PB45C	4		PB60C	4	
AJ28	PB47A	4		PB67A	4	
AH28	PB47B	4		PB67B	4	
AE24	PB47C	4	VREF1_4	PB67C	4	VREF1_4
AE25	PB47D	4		PB67D	4	
AJ29	PB48A	4	LRC_DLLT_IN_C/LRC_DLLT_FB_D	PB68A	4	LRC_DLLT_IN_C/LRC_DLLT_FB_D

LFSC/M15, LFSC/M25 Logic Signal Connections: 900 fpBGA^{1,2} (Cont.)

Ball Number	LFSC/M15			LFSC/M25		
	Ball Function	VCCIO Bank	Dual Function	Ball Function	VCCIO Bank	Dual Function
AH29	PB48B	4	LRC_DLLC_IN_C/LRC_DLLC_FB_D	PB68B	4	LRC_DLLC_IN_C/LRC_DLLC_FB_D
AE26	PB48C	4		PB68C	4	
AD25	PB48D	4		PB68D	4	
AJ30	PB49A	4	LRC_PLLT_IN_A/LRC_PLLT_FB_B	PB69A	4	LRC_PLLT_IN_A/LRC_PLLT_FB_B
AH30	PB49B	4	LRC_PLLC_IN_A/LRC_PLLC_FB_B	PB69B	4	LRC_PLLC_IN_A/LRC_PLLC_FB_B
AG28	PB49C	4	LRC_DLLT_IN_D/LRC_DLLT_FB_C	PB69C	4	LRC_DLLT_IN_D/LRC_DLLT_FB_C
AG29	PB49D	4	LRC_DLLC_IN_D/LRC_DLLC_FB_C	PB69D	4	LRC_DLLC_IN_D/LRC_DLLC_FB_C
AF26	VCC12	-		VCC12	-	
AD27	PROBE_VCC	-		PROBE_VCC	-	
AG27	VCC12	-		VCC12	-	
AE28	PROBE_GND	-		PROBE_GND	-	
AC25	PR45D	3	LRC_PLLC_IN_B/LRC_PLLC_FB_A	PR57D	3	LRC_PLLC_IN_B/LRC_PLLC_FB_A
AD26	PR45C	3	LRC_PLLT_IN_B/LRC_PLLT_FB_A	PR57C	3	LRC_PLLT_IN_B/LRC_PLLT_FB_A
AF28	PR45B	3	LRC_DLLC_IN_F/LRC_DLLC_FB_E	PR57B	3	LRC_DLLC_IN_F/LRC_DLLC_FB_E
AF29	PR45A	3	LRC_DLLT_IN_F/LRC_DLLT_FB_E	PR57A	3	LRC_DLLT_IN_F/LRC_DLLT_FB_E
AC26	PR44D	3	LRC_DLLC_IN_E/LRC_DLLC_FB_F	PR55D	3	LRC_DLLC_IN_E/LRC_DLLC_FB_F
AB26	PR44C	3	LRC_DLLT_IN_E/LRC_DLLT_FB_F	PR55C	3	LRC_DLLT_IN_E/LRC_DLLT_FB_F
AG30	PR44B	3		PR55B	3	
AF30	PR44A	3		PR55A	3	
AC28	PR43B	3		PR52B	3	
AB28	PR43A	3		PR52A	3	
AB27	PR41D	3	VREF2_3	PR51D	3	VREF2_3
AE30	PR41B	3		PR51B	3	
AD30	PR41A	3		PR51A	3	
AB25	PR40B	3		PR49B	3	
AA25	PR40A	3		PR49A	3	
AA30	PR39B	3		PR48B	3	
Y30	PR39A	3		PR48A	3	
W29	PR37B	3		PR44B	3	
V29	PR37A	3		PR44A	3	
U30	PR36B	3		PR43B	3	
T30	PR36A	3		PR43A	3	
V25	PR35D	3	DIFFR_3	PR42D	3	DIFFR_3
W28	PR35B	3		PR42B	3	
V28	PR35A	3		PR42A	3	
R30	PR33B	3		PR38B	3	
P30	PR33A	3		PR38A	3	
N30	PR32B	3		PR35B	3	
M29	PR32A	3		PR35A	3	
U26	PR31D	3		PR34D	3	
T26	PR31C	3	VREF1_3	PR34C	3	VREF1_3
U28	PR31B	3		PR34B	3	
T28	PR31A	3		PR34A	3	
M30	PR28D	3	PCLKC3_2	PR31D	3	PCLKC3_2
L29	PR28C	3	PCLKT3_2	PR31C	3	PCLKT3_2

LFSC/M15, LFSC/M25 Logic Signal Connections: 900 fpBGA^{1,2} (Cont.)

Ball Number	LFSC/M15			LFSC/M25		
	Ball Function	VCCIO Bank	Dual Function	Ball Function	VCCIO Bank	Dual Function
R29	PR28B	3		PR31B	3	
P29	PR28A	3		PR31A	3	
P27	PR27C	3	PCLKT3_3	PR30C	3	PCLKT3_3
N29	PR27B	3		PR30B	3	
N28	PR27A	3		PR30A	3	
R25	PR26D	3	PCLKC3_1	PR29D	3	PCLKC3_1
R26	PR26C	3	PCLKT3_1	PR29C	3	PCLKT3_1
R28	PR26B	3	PCLKC3_0	PR29B	3	PCLKC3_0
P28	PR26A	3	PCLKT3_0	PR29A	3	PCLKT3_0
N27	PR24D	2	PCLKC2_2	PR27D	2	PCLKC2_2
P26	PR24C	2	PCLKT2_2	PR27C	2	PCLKT2_2
L30	PR24B	2	PCLKC2_0	PR27B	2	PCLKC2_0
K30	PR24A	2	PCLKT2_0	PR27A	2	PCLKT2_0
J30	PR23B	2	PCLKC2_1	PR26B	2	PCLKC2_1
H30	PR23A	2	PCLKT2_1	PR26A	2	PCLKT2_1
M26	PR22D	2	DIFFR_2	PR25D	2	DIFFR_2
M25	PR22C	2	VREF1_2	PR25C	2	VREF1_2
G29	PR22B	2		PR25B	2	
F29	PR22A	2		PR25A	2	
H28	PR19D	2		PR22D	2	
J28	PR19C	2		PR22C	2	
E30	PR19B	2		PR22B	2	
E29	PR19A	2		PR22A	2	
L26	PR18D	2	VREF2_2	PR18D	2	VREF2_2
L25	PR18C	2		PR18C	2	
F28	PR18B	2	URC_DLLC_IN_D/URC_DLLC_FB_C	PR18B	2	URC_DLLC_IN_D/URC_DLLC_FB_C
G28	PR18A	2	URC_DLLT_IN_D/URC_DLLT_FB_C	PR18A	2	URC_DLLT_IN_D/URC_DLLT_FB_C
K26	PR17D	2	URC_PLLC_IN_B/URC_PLLC_FB_A	PR17D	2	URC_PLLC_IN_B/URC_PLLC_FB_A
K25	PR17C	2	URC_PLLT_IN_B/URC_PLLT_FB_A	PR17C	2	URC_PLLT_IN_B/URC_PLLT_FB_A
D30	PR17B	2	URC_DLLC_IN_C/URC_DLLC_FB_D	PR17B	2	URC_DLLC_IN_C/URC_DLLC_FB_D
D29	PR17A	2	URC_DLLT_IN_C/URC_DLLT_FB_D	PR17A	2	URC_DLLT_IN_C/URC_DLLT_FB_D
G26	PR15D	2		PR16D	2	
H26	PR15C	2		PR16C	2	
E28	PR15B	2	URC_PLLC_IN_A/URC_PLLC_FB_B	PR16B	2	URC_PLLC_IN_A/URC_PLLC_FB_B
D28	PR15A	2	URC_PLLT_IN_A/URC_PLLT_FB_B	PR16A	2	URC_PLLT_IN_A/URC_PLLT_FB_B
J25	VCCJ	-		VCCJ	-	
H25	TDO	-	TDO	TDO	-	TDO
J26	TMS	-		TMS	-	
G25	TCK	-		TCK	-	
G24	TDI	-		TDI	-	
F26	PROGRAMN	1		PROGRAMN	1	
H24	MPIIRQN	1	CFGIRQN/MPI_IRQ_N	MPIIRQN	1	CFGIRQN/MPI_IRQ_N
F25	CCLK	1		CCLK	1	
D27	VCC12	-		VCC12	-	
E26	VCC12	-		VCC12	-	

LFSC/M15, LFSC/M25 Logic Signal Connections: 900 fpBGA^{1,2} (Cont.)

Ball Number	LFSC/M15			LFSC/M25		
	Ball Function	VCCIO Bank	Dual Function	Ball Function	VCCIO Bank	Dual Function
A29	RESP_URC	-		RESP_URC	-	
D26	VCC12	-		VCC12	-	
C30	A_REFCLKN_R	-		A_REFCLKN_R	-	
B30	A_REFCLKP_R	-		A_REFCLKP_R	-	
F24	A_VDDAX25_R	-		A_VDDAX25_R	-	
D25	VCC12	-		VCC12	-	
C28	A_VDDIB0_R	-		A_VDDIB0_R	-	
B28	A_HDINP0_R	-	PCS 3E0 CH 0 IN P	A_HDINP0_R	-	PCS 3E0 CH 0 IN P
B27	A_HDINN0_R	-	PCS 3E0 CH 0 IN N	A_HDINN0_R	-	PCS 3E0 CH 0 IN N
E25	VCC12	-		VCC12	-	
A28	A_HDOUTP0_R	-	PCS 3E0 CH 0 OUT P	A_HDOUTP0_R	-	PCS 3E0 CH 0 OUT P
C27	A_VDDOB0_R	-		A_VDDOB0_R	-	
A27	A_HDOUTN0_R	-	PCS 3E0 CH 0 OUT N	A_HDOUTN0_R	-	PCS 3E0 CH 0 OUT N
C26	A_VDDOB1_R	-		A_VDDOB1_R	-	
A26	A_HDOUTN1_R	-	PCS 3E0 CH 1 OUT N	A_HDOUTN1_R	-	PCS 3E0 CH 1 OUT N
D24	VCC12	-		VCC12	-	
A25	A_HDOUTP1_R	-	PCS 3E0 CH 1 OUT P	A_HDOUTP1_R	-	PCS 3E0 CH 1 OUT P
B26	A_HDINN1_R	-	PCS 3E0 CH 1 IN N	A_HDINN1_R	-	PCS 3E0 CH 1 IN N
B25	A_HDINP1_R	-	PCS 3E0 CH 1 IN P	A_HDINP1_R	-	PCS 3E0 CH 1 IN P
E24	VCC12	-		VCC12	-	
C25	A_VDDIB1_R	-		A_VDDIB1_R	-	
D23	VCC12	-		VCC12	-	
C24	A_VDDIB2_R	-		A_VDDIB2_R	-	
B24	A_HDINP2_R	-	PCS 3E0 CH 2 IN P	A_HDINP2_R	-	PCS 3E0 CH 2 IN P
B23	A_HDINN2_R	-	PCS 3E0 CH 2 IN N	A_HDINN2_R	-	PCS 3E0 CH 2 IN N
E23	VCC12	-		VCC12	-	
A24	A_HDOUTP2_R	-	PCS 3E0 CH 2 OUT P	A_HDOUTP2_R	-	PCS 3E0 CH 2 OUT P
C23	A_VDDOB2_R	-		A_VDDOB2_R	-	
A23	A_HDOUTN2_R	-	PCS 3E0 CH 2 OUT N	A_HDOUTN2_R	-	PCS 3E0 CH 2 OUT N
C22	A_VDDOB3_R	-		A_VDDOB3_R	-	
A22	A_HDOUTN3_R	-	PCS 3E0 CH 3 OUT N	A_HDOUTN3_R	-	PCS 3E0 CH 3 OUT N
D22	VCC12	-		VCC12	-	
A21	A_HDOUTP3_R	-	PCS 3E0 CH 3 OUT P	A_HDOUTP3_R	-	PCS 3E0 CH 3 OUT P
B22	A_HDINN3_R	-	PCS 3E0 CH 3 IN N	A_HDINN3_R	-	PCS 3E0 CH 3 IN N
B21	A_HDINP3_R	-	PCS 3E0 CH 3 IN P	A_HDINP3_R	-	PCS 3E0 CH 3 IN P
E22	VCC12	-		VCC12	-	
C21	A_VDDIB3_R	-		A_VDDIB3_R	-	
G22	PT43D	1	HDC/SI	PT49D	1	HDC/SI
F22	PT43C	1	LDCN/SCS	PT49C	1	LDCN/SCS
B20	PT41B	1	D8/MPI_DATA8	PT49B	1	D8/MPI_DATA8
B19	PT41A	1	CS1/MPI_CS1	PT49A	1	CS1/MPI_CS1
A20	PT40D	1	D9/MPI_DATA9	PT47D	1	D9/MPI_DATA9
A19	PT40C	1	D10/MPI_DATA10	PT47C	1	D10/MPI_DATA10
D19	PT39B	1	CS0N/MPI_CS0N	PT47B	1	CS0N/MPI_CS0N
D18	PT39A	1	RDN/MPI_STRB_N	PT47A	1	RDN/MPI_STRB_N

LFSC/M15, LFSC/M25 Logic Signal Connections: 900 fpBGA^{1,2} (Cont.)

Ball Number	LFSC/M15			LFSC/M25		
	Ball Function	VCCIO Bank	Dual Function	Ball Function	VCCIO Bank	Dual Function
F19	PT37D	1	WRN/MPI_WR_N	PT46D	1	WRN/MPI_WR_N
F18	PT37C	1	D7/MPI_DATA7	PT46C	1	D7/MPI_DATA7
C18	PT37B	1	D6/MPI_DATA6	PT46B	1	D6/MPI_DATA6
C17	PT37A	1	D5/MPI_DATA5	PT46A	1	D5/MPI_DATA5
E17	PT36D	1	D4/MPI_DATA4	PT45D	1	D4/MPI_DATA4
E16	PT36C	1	D3/MPI_DATA3	PT45C	1	D3/MPI_DATA3
G18	PT35B	1	D2/MPI_DATA2	PT45B	1	D2/MPI_DATA2
G17	PT35A	1	D1/MPI_DATA1	PT45A	1	D1/MPI_DATA1
B18	PT33B	1	D0/MPI_DATA0	PT43B	1	D0/MPI_DATA0
B17	PT33A	1	QOUT/CEON	PT43A	1	QOUT/CEON
G16	PT32D	1	VREF2_1	PT42D	1	VREF2_1
A18	PT32B	1	DOUT	PT42B	1	DOUT
A17	PT32A	1	MCA_DONE_IN	PT42A	1	MCA_DONE_IN
H18	PT31B	1	MCA_CLK_P1_OUT	PT41B	1	MCA_CLK_P1_OUT
H17	PT31A	1	MCA_CLK_P1_IN	PT41A	1	MCA_CLK_P1_IN
D17	PT29B	1	MCA_CLK_P2_OUT	PT39B	1	MCA_CLK_P2_OUT
D16	PT29A	1	MCA_CLK_P2_IN	PT39A	1	MCA_CLK_P2_IN
F17	PT28D	1	MCA_DONE_OUT	PT38D	1	MCA_DONE_OUT
F16	PT28C	1	BUSYN/RCLK/SCK	PT38C	1	BUSYN/RCLK/SCK
C16	PT28B	1	DP0/MPI_PAR0	PT38B	1	DP0/MPI_PAR0
C15	PT28A	1	MPI_TA	PT38A	1	MPI_TA
B16	PT27B	1	PCLKC1_0	PT37B	1	PCLKC1_0
B15	PT27A	1	PCLKT1_0/MPI_CLK	PT37A	1	PCLKT1_0/MPI_CLK
H16	PT25D	1	DP3/PCLKC1_4/MPI_PAR3	PT35D	1	DP3/PCLKC1_4/MPI_PAR3
A16	PT25B	1	MPI_RETRY	PT35B	1	MPI_RETRY
A15	PT25A	1	A0/MPI_ADDR14	PT35A	1	A0/MPI_ADDR14
G15	PT24D	1	A1/MPI_ADDR15	PT33D	1	A1/MPI_ADDR15
F15	PT24C	1	A2/MPI_ADDR16	PT33C	1	A2/MPI_ADDR16
E15	PT24B	1	A3/MPI_ADDR17	PT33B	1	A3/MPI_ADDR17
D15	PT24A	1	A4/MPI_ADDR18	PT33A	1	A4/MPI_ADDR18
C14	PT23B	1	A5/MPI_ADDR19	PT32B	1	A5/MPI_ADDR19
C13	PT23A	1	A6/MPI_ADDR20	PT32A	1	A6/MPI_ADDR20
H14	PT21C	1	VREF1_1	PT31C	1	VREF1_1
B14	PT21B	1	A7/MPI_ADDR21	PT31B	1	A7/MPI_ADDR21
B13	PT21A	1	A8/MPI_ADDR22	PT31A	1	A8/MPI_ADDR22
G14	PT20B	1	A9/MPI_ADDR23	PT29B	1	A9/MPI_ADDR23
F14	PT20A	1	A10/MPI_ADDR24	PT29A	1	A10/MPI_ADDR24
A14	PT19B	1	A11/MPI_ADDR25	PT28B	1	A11/MPI_ADDR25
A13	PT19A	1	A12/MPI_ADDR26	PT28A	1	A12/MPI_ADDR26
G13	PT17D	1	D11/MPI_DATA11	PT27D	1	D11/MPI_DATA11
H13	PT17C	1	D12/MPI_DATA12	PT27C	1	D12/MPI_DATA12
E14	PT17B	1	A13/MPI_ADDR27	PT27B	1	A13/MPI_ADDR27
E13	PT17A	1	A14/MPI_ADDR28	PT27A	1	A14/MPI_ADDR28
G12	PT15D	1	A16/MPI_ADDR30	PT25D	1	A16/MPI_ADDR30
G11	PT15C	1	D13/MPI_DATA13	PT25C	1	D13/MPI_DATA13

LFSC/M15, LFSC/M25 Logic Signal Connections: 900 fpBGA^{1,2} (Cont.)

Ball Number	LFSC/M15			LFSC/M25		
	Ball Function	VCCIO Bank	Dual Function	Ball Function	VCCIO Bank	Dual Function
D14	PT15B	1	A15/MPI_ADDR29	PT25B	1	A15/MPI_ADDR29
D13	PT15A	1	A17/MPI_ADDR31	PT25A	1	A17/MPI_ADDR31
F12	PT13D	1	A19/MPI_TSIZ1	PT24D	1	A19/MPI_TSIZ1
F13	PT13C	1	A20/MPI_BDIP	PT24C	1	A20/MPI_BDIP
B12	PT11B	1	A18/MPI_TSIZ0	PT24B	1	A18/MPI_TSIZ0
B11	PT11A	1	MPI_TEA	PT24A	1	MPI_TEA
E12	PT10D	1	D14/MPI_DATA14	PT23D	1	D14/MPI_DATA14
D12	PT10C	1	DP1/MPI_PAR1	PT23C	1	DP1/MPI_PAR1
G10	PT9B	1	A21/MPI_BURST	PT23B	1	A21/MPI_BURST
G9	PT9A	1	D15/MPI_DATA15	PT23A	1	D15/MPI_DATA15
C10	A_VDDIB3_L	-		A_VDDIB3_L	-	
E9	VCC12	-		VCC12	-	
B10	A_HDINP3_L	-	PCS 360 CH 3 IN P	A_HDINP3_L	-	PCS 360 CH 3 IN P
B9	A_HDINN3_L	-	PCS 360 CH 3 IN N	A_HDINN3_L	-	PCS 360 CH 3 IN N
A10	A_HDOUTP3_L	-	PCS 360 CH 3 OUT P	A_HDOUTP3_L	-	PCS 360 CH 3 OUT P
D9	VCC12	-		VCC12	-	
A9	A_HDOUTN3_L	-	PCS 360 CH 3 OUT N	A_HDOUTN3_L	-	PCS 360 CH 3 OUT N
C9	A_VDDOB3_L	-		A_VDDOB3_L	-	
A8	A_HDOUTN2_L	-	PCS 360 CH 2 OUT N	A_HDOUTN2_L	-	PCS 360 CH 2 OUT N
C8	A_VDDOB2_L	-		A_VDDOB2_L	-	
A7	A_HDOUTP2_L	-	PCS 360 CH 2 OUT P	A_HDOUTP2_L	-	PCS 360 CH 2 OUT P
E8	VCC12	-		VCC12	-	
B8	A_HDINN2_L	-	PCS 360 CH 2 IN N	A_HDINN2_L	-	PCS 360 CH 2 IN N
B7	A_HDINP2_L	-	PCS 360 CH 2 IN P	A_HDINP2_L	-	PCS 360 CH 2 IN P
C7	A_VDDIB2_L	-		A_VDDIB2_L	-	
D8	VCC12	-		VCC12	-	
C6	A_VDDIB1_L	-		A_VDDIB1_L	-	
E7	VCC12	-		VCC12	-	
B6	A_HDINP1_L	-	PCS 360 CH 1 IN P	A_HDINP1_L	-	PCS 360 CH 1 IN P
B5	A_HDINN1_L	-	PCS 360 CH 1 IN N	A_HDINN1_L	-	PCS 360 CH 1 IN N
A6	A_HDOUTP1_L	-	PCS 360 CH 1 OUT P	A_HDOUTP1_L	-	PCS 360 CH 1 OUT P
D7	VCC12	-		VCC12	-	
A5	A_HDOUTN1_L	-	PCS 360 CH 1 OUT N	A_HDOUTN1_L	-	PCS 360 CH 1 OUT N
C5	A_VDDOB1_L	-		A_VDDOB1_L	-	
A4	A_HDOUTN0_L	-	PCS 360 CH 0 OUT N	A_HDOUTN0_L	-	PCS 360 CH 0 OUT N
C4	A_VDDOB0_L	-		A_VDDOB0_L	-	
A3	A_HDOUTP0_L	-	PCS 360 CH 0 OUT P	A_HDOUTP0_L	-	PCS 360 CH 0 OUT P
E6	VCC12	-		VCC12	-	
B4	A_HDINN0_L	-	PCS 360 CH 0 IN N	A_HDINN0_L	-	PCS 360 CH 0 IN N
B3	A_HDINP0_L	-	PCS 360 CH 0 IN P	A_HDINP0_L	-	PCS 360 CH 0 IN P
C3	A_VDDIB0_L	-		A_VDDIB0_L	-	
D6	VCC12	-		VCC12	-	
L5	NC	-		PL21A	7	
M5	NC	-		PL21B	7	
G2	NC	-		PL20A	7	

LFSC/M15, LFSC/M25 Logic Signal Connections: 900 fpBGA^{1,2} (Cont.)

Ball Number	LFSC/M15			LFSC/M25		
	Ball Function	VCCIO Bank	Dual Function	Ball Function	VCCIO Bank	Dual Function
G1	NC	-		PL20B	7	
M4	NC	-		NC	-	
J3	NC	-		NC	-	
P5	NC	-		NC	-	
W5	NC	-		PL48C	6	
T6	NC	-		PL35C	6	
U3	NC	-		PL36A	6	
V3	NC	-		PL36B	6	
T5	NC	-		PL39A	6	
T4	NC	-		PL39B	6	
V5	NC	-		PL43C	6	
U6	NC	-		PL42C	6	
U4	NC	-		PL40A	6	
U5	NC	-		PL40B	6	
V4	NC	-		PL43D	6	
Y2	NC	-		PL47A	6	
AA2	NC	-		PL47B	6	
W3	NC	-		PL47D	6	
Y3	NC	-		PL47C	6	
AB3	NC	-		NC	-	
AC4	NC	-		PL53A	6	
AD4	NC	-		PL53B	6	
AE3	NC	-		PL56A	6	
AF3	NC	-		PL56B	6	
AF7	NC	-		PB7A	5	
AF6	NC	-		PB7B	5	
AH4	NC	-		PB8A	5	
AG5	NC	-		PB8B	5	
AF8	NC	-		PB9A	5	
AG8	NC	-		PB9B	5	
AG7	NC	-		NC	-	
AG10	NC	-		NC	-	
AF12	NC	-		NC	-	
AH7	NC	-		PB15A	5	
AE13	NC	-		PB15D	5	
AG13	NC	-		PB23C	5	
AH8	NC	-		PB15B	5	
AJ5	NC	-		PB17A	5	
AJ6	NC	-		PB17B	5	
AF15	NC	-		PB21D	5	
AJ7	NC	-		PB19A	5	
AJ8	NC	-		PB19B	5	
AE12	NC	-		PB15C	5	
AF16	NC	-		PB38D	4	
AF19	NC	-		PB49D	4	

LFSC/M15, LFSC/M25 Logic Signal Connections: 900 fpBGA^{1,2} (Cont.)

Ball Number	LFSC/M15			LFSC/M25		
	Ball Function	VCCIO Bank	Dual Function	Ball Function	VCCIO Bank	Dual Function
AH20	NC	-		PB51D	4	
AK27	NC	-		NC	-	
AJ24	NC	-		NC	-	
AF17	NC	-		PB42C	4	
AH27	NC	-		PB61B	4	
AD23	NC	-		PB57A	4	
AE23	NC	-		PB57B	4	
AH24	NC	-		PB59A	4	
AH25	NC	-		PB59B	4	
AH26	NC	-		PB61A	4	
AF24	NC	-		PB63A	4	
AG24	NC	-		PB63B	4	
AG25	NC	-		PB64A	4	
AF25	NC	-		PB64B	4	
AG26	NC	-		PB65A	4	
AF27	NC	-		PB65B	4	
AD28	NC	-		PR56B	3	
AC27	NC	-		PR56A	3	
AE29	NC	-		PR53B	3	
AD29	NC	-		PR53A	3	
AB30	NC	-		NC	-	
AA28	NC	-		NC	-	
Y27	NC	-		PR47C	3	
W27	NC	-		PR47D	3	
V30	NC	-		PR47A	3	
W30	NC	-		PR47B	3	
W26	NC	-		PR43D	3	
V26	NC	-		PR43C	3	
U25	NC	-		PR42C	3	
T27	NC	-		PR40B	3	
R27	NC	-		PR40A	3	
V27	NC	-		PR39B	3	
U27	NC	-		PR39A	3	
U29	NC	-		PR36B	3	
T29	NC	-		PR36A	3	
T24	NC	-		PR35C	3	
Y25	NC	-		PR48C	3	
P24	NC	-		NC	-	
K28	NC	-		NC	-	
P23	NC	-		NC	-	
L28	NC	-		NC	-	
M27	NC	-		PR21B	2	
L27	NC	-		PR21A	2	
H27	NC	-		PR20B	2	
G27	NC	-		PR20A	2	

LFSC/M15, LFSC/M25 Logic Signal Connections: 900 fpBGA^{1, 2} (Cont.)

Ball Number	LFSC/M15			LFSC/M25		
	Ball Function	VCCIO Bank	Dual Function	Ball Function	VCCIO Bank	Dual Function
E19	NC	-		NC	-	
G21	NC	-		NC	-	
G20	NC	-		NC	-	
G19	NC	-		NC	-	
F9	NC	-		NC	-	
A11	NC	-		NC	-	
G7	NC	-		NC	-	
AH9	NC	-		NC	-	
H8	VCC12	-		VCC12	-	
T8	VCC12	-		VCC12	-	
AB9	VCC12	-		VCC12	-	
AC8	VCC12	-		VCC12	-	
AB22	VCC12	-		VCC12	-	
AC23	VCC12	-		VCC12	-	
R23	VCC12	-		VCC12	-	
H23	VCC12	-		VCC12	-	
H15	VCC12	-		VCC12	-	
L24	VTT_2	2		VTT_2	2	
T23	VTT_2	2		VTT_2	2	
AC24	VTT_3	3		VTT_3	3	
T25	VTT_3	3		VTT_3	3	
W25	VTT_3	3		VTT_3	3	
AD24	VTT_4	4		VTT_4	4	
AE17	VTT_4	4		VTT_4	4	
AE18	VTT_4	4		VTT_4	4	
AC15	VTT_5	5		VTT_5	5	
AD16	VTT_5	5		VTT_5	5	
AE9	VTT_5	5		VTT_5	5	
AA6	VTT_6	6		VTT_6	6	
T7	VTT_6	6		VTT_6	6	
W6	VTT_6	6		VTT_6	6	
L7	VTT_7	7		VTT_7	7	
P7	VTT_7	7		VTT_7	7	
AA10	VCC	-		VCC	-	
AA11	VCC	-		VCC	-	
AA12	VCC	-		VCC	-	
AA13	VCC	-		VCC	-	
AA14	VCC	-		VCC	-	
AA17	VCC	-		VCC	-	
AA18	VCC	-		VCC	-	
AA19	VCC	-		VCC	-	
AA20	VCC	-		VCC	-	
AA21	VCC	-		VCC	-	
AA22	VCC	-		VCC	-	
AA9	VCC	-		VCC	-	

LFSC/M15, LFSC/M25 Logic Signal Connections: 900 fpBGA^{1, 2} (Cont.)

Ball Number	LFSC/M15			LFSC/M25		
	Ball Function	VCCIO Bank	Dual Function	Ball Function	VCCIO Bank	Dual Function
AB10	VCC	-		VCC	-	
AB21	VCC	-		VCC	-	
J10	VCC	-		VCC	-	
J21	VCC	-		VCC	-	
K10	VCC	-		VCC	-	
K11	VCC	-		VCC	-	
K12	VCC	-		VCC	-	
K13	VCC	-		VCC	-	
K14	VCC	-		VCC	-	
K17	VCC	-		VCC	-	
K18	VCC	-		VCC	-	
K19	VCC	-		VCC	-	
K20	VCC	-		VCC	-	
K21	VCC	-		VCC	-	
K22	VCC	-		VCC	-	
K9	VCC	-		VCC	-	
L10	VCC	-		VCC	-	
L21	VCC	-		VCC	-	
M10	VCC	-		VCC	-	
M21	VCC	-		VCC	-	
N10	VCC	-		VCC	-	
N21	VCC	-		VCC	-	
P10	VCC	-		VCC	-	
P21	VCC	-		VCC	-	
U10	VCC	-		VCC	-	
U21	VCC	-		VCC	-	
V10	VCC	-		VCC	-	
V21	VCC	-		VCC	-	
W10	VCC	-		VCC	-	
W21	VCC	-		VCC	-	
Y10	VCC	-		VCC	-	
Y21	VCC	-		VCC	-	
H11	VCCAUX	-		VCCAUX	-	
H12	VCCAUX	-		VCCAUX	-	
H19	VCCAUX	-		VCCAUX	-	
H20	VCCAUX	-		VCCAUX	-	
M23	VCCAUX	-		VCCAUX	-	
M24	VCCAUX	-		VCCAUX	-	
N23	VCCAUX	-		VCCAUX	-	
N24	VCCAUX	-		VCCAUX	-	
U23	VCCAUX	-		VCCAUX	-	
U24	VCCAUX	-		VCCAUX	-	
V23	VCCAUX	-		VCCAUX	-	
V24	VCCAUX	-		VCCAUX	-	
W23	VCCAUX	-		VCCAUX	-	

LFSC/M15, LFSC/M25 Logic Signal Connections: 900 fpBGA^{1, 2} (Cont.)

Ball Number	LFSC/M15			LFSC/M25		
	Ball Function	VCCIO Bank	Dual Function	Ball Function	VCCIO Bank	Dual Function
W24	VCCAUX	-		VCCAUX	-	
AC17	VCCAUX	-		VCCAUX	-	
AC18	VCCAUX	-		VCCAUX	-	
AC19	VCCAUX	-		VCCAUX	-	
AD17	VCCAUX	-		VCCAUX	-	
AD18	VCCAUX	-		VCCAUX	-	
AD19	VCCAUX	-		VCCAUX	-	
AC12	VCCAUX	-		VCCAUX	-	
AC13	VCCAUX	-		VCCAUX	-	
AC14	VCCAUX	-		VCCAUX	-	
AD12	VCCAUX	-		VCCAUX	-	
AD13	VCCAUX	-		VCCAUX	-	
AD14	VCCAUX	-		VCCAUX	-	
U7	VCCAUX	-		VCCAUX	-	
U8	VCCAUX	-		VCCAUX	-	
V7	VCCAUX	-		VCCAUX	-	
V8	VCCAUX	-		VCCAUX	-	
W7	VCCAUX	-		VCCAUX	-	
W8	VCCAUX	-		VCCAUX	-	
M7	VCCAUX	-		VCCAUX	-	
M8	VCCAUX	-		VCCAUX	-	
N7	VCCAUX	-		VCCAUX	-	
N8	VCCAUX	-		VCCAUX	-	
H10	VCCIO1	-		VCCIO1	-	
H21	VCCIO1	-		VCCIO1	-	
H22	VCCIO1	-		VCCIO1	-	
H9	VCCIO1	-		VCCIO1	-	
J11	VCCIO1	-		VCCIO1	-	
J12	VCCIO1	-		VCCIO1	-	
J13	VCCIO1	-		VCCIO1	-	
J14	VCCIO1	-		VCCIO1	-	
J15	VCCIO1	-		VCCIO1	-	
J16	VCCIO1	-		VCCIO1	-	
J17	VCCIO1	-		VCCIO1	-	
J18	VCCIO1	-		VCCIO1	-	
J19	VCCIO1	-		VCCIO1	-	
J20	VCCIO1	-		VCCIO1	-	
J23	VCCIO2	-		VCCIO2	-	
J24	VCCIO2	-		VCCIO2	-	
K23	VCCIO2	-		VCCIO2	-	
K24	VCCIO2	-		VCCIO2	-	
L22	VCCIO2	-		VCCIO2	-	
L23	VCCIO2	-		VCCIO2	-	
M22	VCCIO2	-		VCCIO2	-	
N22	VCCIO2	-		VCCIO2	-	

LFSC/M15, LFSC/M25 Logic Signal Connections: 900 fpBGA^{1, 2} (Cont.)

Ball Number	LFSC/M15			LFSC/M25		
	Ball Function	VCCIO Bank	Dual Function	Ball Function	VCCIO Bank	Dual Function
P22	VCCIO2	-		VCCIO2	-	
R22	VCCIO2	-		VCCIO2	-	
AA23	VCCIO3	-		VCCIO3	-	
AA24	VCCIO3	-		VCCIO3	-	
AB23	VCCIO3	-		VCCIO3	-	
AB24	VCCIO3	-		VCCIO3	-	
T22	VCCIO3	-		VCCIO3	-	
U22	VCCIO3	-		VCCIO3	-	
V22	VCCIO3	-		VCCIO3	-	
W22	VCCIO3	-		VCCIO3	-	
Y22	VCCIO3	-		VCCIO3	-	
Y23	VCCIO3	-		VCCIO3	-	
Y24	VCCIO3	-		VCCIO3	-	
AB16	VCCIO4	-		VCCIO4	-	
AB17	VCCIO4	-		VCCIO4	-	
AB18	VCCIO4	-		VCCIO4	-	
AB19	VCCIO4	-		VCCIO4	-	
AB20	VCCIO4	-		VCCIO4	-	
AC20	VCCIO4	-		VCCIO4	-	
AC21	VCCIO4	-		VCCIO4	-	
AC22	VCCIO4	-		VCCIO4	-	
AD20	VCCIO4	-		VCCIO4	-	
AD21	VCCIO4	-		VCCIO4	-	
AD22	VCCIO4	-		VCCIO4	-	
AB11	VCCIO5	-		VCCIO5	-	
AB12	VCCIO5	-		VCCIO5	-	
AB13	VCCIO5	-		VCCIO5	-	
AB14	VCCIO5	-		VCCIO5	-	
AB15	VCCIO5	-		VCCIO5	-	
AC10	VCCIO5	-		VCCIO5	-	
AC11	VCCIO5	-		VCCIO5	-	
AC9	VCCIO5	-		VCCIO5	-	
AD10	VCCIO5	-		VCCIO5	-	
AD11	VCCIO5	-		VCCIO5	-	
AD9	VCCIO5	-		VCCIO5	-	
AA7	VCCIO6	-		VCCIO6	-	
AA8	VCCIO6	-		VCCIO6	-	
AB7	VCCIO6	-		VCCIO6	-	
AB8	VCCIO6	-		VCCIO6	-	
T9	VCCIO6	-		VCCIO6	-	
U9	VCCIO6	-		VCCIO6	-	
V9	VCCIO6	-		VCCIO6	-	
W9	VCCIO6	-		VCCIO6	-	
Y7	VCCIO6	-		VCCIO6	-	
Y8	VCCIO6	-		VCCIO6	-	

LFSC/M15, LFSC/M25 Logic Signal Connections: 900 fpBGA^{1,2} (Cont.)

Ball Number	LFSC/M15			LFSC/M25		
	Ball Function	VCCIO Bank	Dual Function	Ball Function	VCCIO Bank	Dual Function
Y9	VCCIO6	-		VCCIO6	-	
J7	VCCIO7	-		VCCIO7	-	
J8	VCCIO7	-		VCCIO7	-	
K7	VCCIO7	-		VCCIO7	-	
K8	VCCIO7	-		VCCIO7	-	
L8	VCCIO7	-		VCCIO7	-	
L9	VCCIO7	-		VCCIO7	-	
M9	VCCIO7	-		VCCIO7	-	
N9	VCCIO7	-		VCCIO7	-	
P9	VCCIO7	-		VCCIO7	-	
R9	VCCIO7	-		VCCIO7	-	
A1	GND	-		GND	-	
A30	GND	-		GND	-	
AA15	GND	-		GND	-	
AA16	GND	-		GND	-	
AK1	GND	-		GND	-	
AK30	GND	-		GND	-	
K15	GND	-		GND	-	
K16	GND	-		GND	-	
L11	GND	-		GND	-	
L12	GND	-		GND	-	
L13	GND	-		GND	-	
L14	GND	-		GND	-	
L15	GND	-		GND	-	
L16	GND	-		GND	-	
L17	GND	-		GND	-	
L18	GND	-		GND	-	
L19	GND	-		GND	-	
L20	GND	-		GND	-	
M11	GND	-		GND	-	
M12	GND	-		GND	-	
M13	GND	-		GND	-	
M14	GND	-		GND	-	
M15	GND	-		GND	-	
M16	GND	-		GND	-	
M17	GND	-		GND	-	
M18	GND	-		GND	-	
M19	GND	-		GND	-	
M20	GND	-		GND	-	
N11	GND	-		GND	-	
N12	GND	-		GND	-	
N13	GND	-		GND	-	
N14	GND	-		GND	-	
N15	GND	-		GND	-	
N16	GND	-		GND	-	

LFSC/M15, LFSC/M25 Logic Signal Connections: 900 fpBGA^{1, 2} (Cont.)

Ball Number	LFSC/M15			LFSC/M25		
	Ball Function	VCCIO Bank	Dual Function	Ball Function	VCCIO Bank	Dual Function
N17	GND	-		GND	-	
N18	GND	-		GND	-	
N19	GND	-		GND	-	
N20	GND	-		GND	-	
P11	GND	-		GND	-	
P12	GND	-		GND	-	
P13	GND	-		GND	-	
P14	GND	-		GND	-	
P15	GND	-		GND	-	
P16	GND	-		GND	-	
P17	GND	-		GND	-	
P18	GND	-		GND	-	
P19	GND	-		GND	-	
P20	GND	-		GND	-	
R10	GND	-		GND	-	
R11	GND	-		GND	-	
R12	GND	-		GND	-	
R13	GND	-		GND	-	
R14	GND	-		GND	-	
R15	GND	-		GND	-	
R16	GND	-		GND	-	
R17	GND	-		GND	-	
R18	GND	-		GND	-	
R19	GND	-		GND	-	
R20	GND	-		GND	-	
R21	GND	-		GND	-	
T10	GND	-		GND	-	
T11	GND	-		GND	-	
T12	GND	-		GND	-	
T13	GND	-		GND	-	
T14	GND	-		GND	-	
T15	GND	-		GND	-	
T16	GND	-		GND	-	
T17	GND	-		GND	-	
T18	GND	-		GND	-	
T19	GND	-		GND	-	
T20	GND	-		GND	-	
T21	GND	-		GND	-	
U11	GND	-		GND	-	
U12	GND	-		GND	-	
U13	GND	-		GND	-	
U14	GND	-		GND	-	
U15	GND	-		GND	-	
U16	GND	-		GND	-	
U17	GND	-		GND	-	

LFSC/M15, LFSC/M25 Logic Signal Connections: 900 fpBGA^{1,2} (Cont.)

Ball Number	LFSC/M15			LFSC/M25		
	Ball Function	VCCIO Bank	Dual Function	Ball Function	VCCIO Bank	Dual Function
U18	GND	-		GND	-	
U19	GND	-		GND	-	
U20	GND	-		GND	-	
V11	GND	-		GND	-	
V12	GND	-		GND	-	
V13	GND	-		GND	-	
V14	GND	-		GND	-	
V15	GND	-		GND	-	
V16	GND	-		GND	-	
V17	GND	-		GND	-	
V18	GND	-		GND	-	
V19	GND	-		GND	-	
V20	GND	-		GND	-	
W11	GND	-		GND	-	
W12	GND	-		GND	-	
W13	GND	-		GND	-	
W14	GND	-		GND	-	
W15	GND	-		GND	-	
W16	GND	-		GND	-	
W17	GND	-		GND	-	
W18	GND	-		GND	-	
W19	GND	-		GND	-	
W20	GND	-		GND	-	
Y11	GND	-		GND	-	
Y12	GND	-		GND	-	
Y13	GND	-		GND	-	
Y14	GND	-		GND	-	
Y15	GND	-		GND	-	
Y16	GND	-		GND	-	
Y17	GND	-		GND	-	
Y18	GND	-		GND	-	
Y19	GND	-		GND	-	
Y20	GND	-		GND	-	
H2	VCCIO7	-		VCCIO7	-	
N4	VCCIO7	-		VCCIO7	-	
N6	VCCIO7	-		VCCIO7	-	
J2	VCCIO7	-		VCCIO7	-	
L2	VCCIO7	-		VCCIO7	-	
H4	VCCIO7	-		VCCIO7	-	
AB2	VCCIO6	-		VCCIO6	-	
AD1	VCCIO6	-		VCCIO6	-	
W4	VCCIO6	-		VCCIO6	-	
AA4	VCCIO6	-		VCCIO6	-	
AE7	VCCIO5	-		VCCIO5	-	
AH6	VCCIO5	-		VCCIO5	-	

LFSC/M15, LFSC/M25 Logic Signal Connections: 900 fpBGA^{1,2} (Cont.)

Ball Number	LFSC/M15			LFSC/M25		
	Ball Function	VCCIO Bank	Dual Function	Ball Function	VCCIO Bank	Dual Function
AG11	VCCIO5	-		VCCIO5	-	
AJ9	VCCIO5	-		VCCIO5	-	
AJ23	VCCIO4	-		VCCIO4	-	
AG20	VCCIO4	-		VCCIO4	-	
AJ26	VCCIO4	-		VCCIO4	-	
AG23	VCCIO4	-		VCCIO4	-	
AC29	VCCIO3	-		VCCIO3	-	
AA26	VCCIO3	-		VCCIO3	-	
Y28	VCCIO3	-		VCCIO3	-	
AA29	VCCIO3	-		VCCIO3	-	
G30	VCCIO2	-		VCCIO2	-	
J29	VCCIO2	-		VCCIO2	-	
K27	VCCIO2	-		VCCIO2	-	
N25	VCCIO2	-		VCCIO2	-	
F20	VCCIO1	-		VCCIO1	-	
C19	VCCIO1	-		VCCIO1	-	
C12	VCCIO1	-		VCCIO1	-	
F11	VCCIO1	-		VCCIO1	-	
H1	GND	-		GND	-	
L4	GND	-		GND	-	
M3	GND	-		GND	-	
N5	GND	-		GND	-	
K2	GND	-		GND	-	
M2	GND	-		GND	-	
P6	GND	-		GND	-	
G4	GND	-		GND	-	
H3	GND	-		GND	-	
AC2	GND	-		GND	-	
AA3	GND	-		GND	-	
AE1	GND	-		GND	-	
Y4	GND	-		GND	-	
AB4	GND	-		GND	-	
AA5	GND	-		GND	-	
AE6	GND	-		GND	-	
AE8	GND	-		GND	-	
AH5	GND	-		GND	-	
AG9	GND	-		GND	-	
AG6	GND	-		GND	-	
AF11	GND	-		GND	-	
AG12	GND	-		GND	-	
AJ10	GND	-		GND	-	
AK26	GND	-		GND	-	
AJ22	GND	-		GND	-	
AF20	GND	-		GND	-	
AJ25	GND	-		GND	-	

LFSC/M15, LFSC/M25 Logic Signal Connections: 900 fpBGA^{1, 2} (Cont.)

Ball Number	LFSC/M15			LFSC/M25		
	Ball Function	VCCIO Bank	Dual Function	Ball Function	VCCIO Bank	Dual Function
AJ27	GND	-		GND	-	
AF23	GND	-		GND	-	
AF22	GND	-		GND	-	
AE27	GND	-		GND	-	
AA27	GND	-		GND	-	
AB29	GND	-		GND	-	
Y26	GND	-		GND	-	
AC30	GND	-		GND	-	
Y29	GND	-		GND	-	
F30	GND	-		GND	-	
E27	GND	-		GND	-	
F27	GND	-		GND	-	
P25	GND	-		GND	-	
H29	GND	-		GND	-	
K29	GND	-		GND	-	
R24	GND	-		GND	-	
M28	GND	-		GND	-	
J27	GND	-		GND	-	
N26	GND	-		GND	-	
E20	GND	-		GND	-	
E21	GND	-		GND	-	
F21	GND	-		GND	-	
F23	GND	-		GND	-	
G23	GND	-		GND	-	
D21	GND	-		GND	-	
D20	GND	-		GND	-	
E18	GND	-		GND	-	
C20	GND	-		GND	-	
C11	GND	-		GND	-	
A12	GND	-		GND	-	
E11	GND	-		GND	-	
F8	GND	-		GND	-	
G8	GND	-		GND	-	
D11	GND	-		GND	-	
D10	GND	-		GND	-	
H7	GND	-		GND	-	
F10	GND	-		GND	-	
E10	GND	-		GND	-	
AC16	NC	-		NC	-	
J22	VCC	-		VCC	-	
J9	VCC	-		VCC	-	
B2	NC	-		NC	-	
C2	RESPN_ULC	-		RESPN_ULC	-	
C29	RESPN_URC	-		RESPN_URC	-	

LFSC/M15, LFSC/M25 Logic Signal Connections: 900 fpBGA^{1, 2} (Cont.)

Ball Number	LFSC/M15			LFSC/M25		
	Ball Function	VCCIO Bank	Dual Function	Ball Function	VCCIO Bank	Dual Function
B29	NC	-		NC	-	

1. Differential pair grouping within a PIC is A (True) and B (Complement) and C (True) and D (Complement).
2. The LatticeSC/M15 and LatticeSC/M25 in a 900-pin package supports a 16-bit MPI interface.

LFSC/M25, LFSC/M40 Logic Signal Connections: 1020 fcBGA^{1,2}

Ball Number	LFSC/M25			LFSC/M40		
	Ball Function	VCCIO Bank	Dual Function	Ball Function	VCCIO Bank	Dual Function
C28	A_REFCLKP_L	-		A_REFCLKP_L	-	
D28	A_REFCLKN_L	-		A_REFCLKN_L	-	
B28	VCC12	-		VCC12	-	
F28	RESP_ULC	-		RESP_ULC	-	
J21	RESETN	1		RESETN	1	
J20	TSALLN	1		TSALLN	1	
K20	DONE	1		DONE	1	
K21	INITN	1		INITN	1	
K23	M0	1		M0	1	
J23	M1	1		M1	1	
J24	M2	1		M2	1	
K24	M3	1		M3	1	
K25	PL16A	7	ULC_PLLT_IN_A/ULC_PLLT_FB_B	PL16A	7	ULC_PLLT_IN_A/ULC_PLLT_FB_B
J25	PL16B	7	ULC_PLLC_IN_A/ULC_PLLC_FB_B	PL16B	7	ULC_PLLC_IN_A/ULC_PLLC_FB_B
K26	PL16C	7		PL16C	7	
K27	PL16D	7		PL16D	7	
D32	PL17A	7	ULC_DLLT_IN_C/ULC_DLLT_FB_D	PL17A	7	ULC_DLLT_IN_C/ULC_DLLT_FB_D
D31	PL17B	7	ULC_DLLC_IN_C/ULC_DLLC_FB_D	PL17B	7	ULC_DLLC_IN_C/ULC_DLLC_FB_D
M23	PL17C	7	ULC_PLLT_IN_B/ULC_PLLT_FB_A	PL17C	7	ULC_PLLT_IN_B/ULC_PLLT_FB_A
N23	PL17D	7	ULC_PLLC_IN_B/ULC_PLLC_FB_A	PL17D	7	ULC_PLLC_IN_B/ULC_PLLC_FB_A
E32	PL18A	7	ULC_DLLT_IN_D/ULC_DLLT_FB_C	PL18A	7	ULC_DLLT_IN_D/ULC_DLLT_FB_C
E31	PL18B	7	ULC_DLLC_IN_D/ULC_DLLC_FB_C	PL18B	7	ULC_DLLC_IN_D/ULC_DLLC_FB_C
J28	PL18C	7		PL18C	7	
K28	PL18D	7	VREF2_7	PL18D	7	VREF2_7
F32	PL20A	7		PL21A	7	
F31	PL20B	7		PL21B	7	
L25	PL20C	7		PL21C	7	
L26	PL20D	7		PL21D	7	
G31	PL21A	7		PL22A	7	
G32	PL21B	7		PL22B	7	
J29	PL22A	7		PL25A	7	
H29	PL22B	7		PL25B	7	
M25	PL22C	7		PL25C	7	
N25	PL22D	7		PL25D	7	
H31	PL25A	7		PL23A	7	
H32	PL25B	7		PL23B	7	
M24	PL25C	7	VREF1_7	PL23C	7	VREF1_7
N24	PL25D	7	DIFFR_7	PL23D	7	DIFFR_7
L32	PL26A	7	PCLKT7_1	PL35A	7	PCLKT7_1
M32	PL26B	7	PCLKC7_1	PL35B	7	PCLKC7_1
R25	PL26C	7	PCLKT7_3	PL35C	7	PCLKT7_3
R24	PL26D	7	PCLKC7_3	PL35D	7	PCLKC7_3
N31	PL27A	7	PCLKT7_0	PL36A	7	PCLKT7_0
N32	PL27B	7	PCLKC7_0	PL36B	7	PCLKC7_0
P27	PL27C	7	PCLKT7_2	PL36C	7	PCLKT7_2
P28	PL27D	7	PCLKC7_2	PL36D	7	PCLKC7_2
P30	PL29A	6	PCLKT6_0	PL38A	6	PCLKT6_0
P29	PL29B	6	PCLKC6_0	PL38B	6	PCLKC6_0
T23	PL29C	6	PCLKT6_1	PL38C	6	PCLKT6_1
T24	PL29D	6	PCLKC6_1	PL38D	6	PCLKC6_1

LFSC/M25, LFSC/M40 Logic Signal Connections: 1020 fcBGA^{1,2} (Cont.)

Ball Number	LFSC/M25			LFSC/M40		
	Ball Function	VCCIO Bank	Dual Function	Ball Function	VCCIO Bank	Dual Function
P32	PL30A	6		PL39A	6	
P31	PL30B	6		PL39B	6	
R28	PL30C	6	PCLKT6_3	PL39C	6	PCLKT6_3
T28	PL30D	6	PCLKC6_3	PL39D	6	PCLKC6_3
R30	PL31A	6		PL40A	6	
R29	PL31B	6		PL40B	6	
T25	PL31C	6	PCLKT6_2	PL40C	6	PCLKT6_2
T26	PL31D	6	PCLKC6_2	PL40D	6	PCLKC6_2
R31	PL34A	6		PL43A	6	
R32	PL34B	6		PL43B	6	
U23	PL34C	6	VREF1_6	PL43C	6	VREF1_6
U24	PL34D	6		PL43D	6	
T31	PL35A	6		PL44A	6	
T32	PL35B	6		PL44B	6	
T27	PL35C	6		PL44C	6	
U28	PL35D	6		PL44D	6	
U32	PL36A	6		PL45A	6	
U31	PL36B	6		PL45B	6	
U26	PL36C	6		PL45C	6	
U25	PL36D	6		PL45D	6	
V32	PL38A	6		PL47A	6	
V31	PL38B	6		PL47B	6	
V24	PL38C	6		PL47C	6	
V23	PL38D	6		PL47D	6	
V29	PL39A	6		PL48A	6	
V30	PL39B	6		PL48B	6	
U27	PL39C	6		PL48C	6	
V28	PL39D	6		PL48D	6	
W30	PL40A	6		PL49A	6	
W29	PL40B	6		PL49B	6	
V25	PL40C	6		PL49C	6	
W26	PL40D	6		PL49D	6	
W31	PL42A	6		PL51A	6	
Y31	PL42B	6		PL51B	6	
W27	PL42C	6		PL51C	6	
Y27	PL42D	6	DIFFR_6	PL51D	6	DIFFR_6
W28	PL43A	6		PL52A	6	
Y28	PL43B	6		PL52B	6	
Y26	PL43C	6		PL52C	6	
W25	PL43D	6		PL52D	6	
W32	PL44A	6		PL53A	6	
Y32	PL44B	6		PL53B	6	
AB28	PL44C	6		PL53C	6	
AA28	PL44D	6		PL53D	6	
AB32	PL47A	6		PL60A	6	
AA32	PL47B	6		PL60B	6	
AB27	PL47C	6		PL60C	6	
AC27	PL47D	6		PL60D	6	
AD31	PL48A	6		PL61A	6	
AC31	PL48B	6		PL61B	6	

LFSC/M25, LFSC/M40 Logic Signal Connections: 1020 fcBGA^{1,2} (Cont.)

Ball Number	LFSC/M25			LFSC/M40		
	Ball Function	VCCIO Bank	Dual Function	Ball Function	VCCIO Bank	Dual Function
Y24	PL48C	6		PL61C	6	
Y23	PL48D	6		PL61D	6	
AD29	PL49A	6		PL62A	6	
AD30	PL49B	6		PL62B	6	
AF28	PL49C	6		PL62C	6	
AE28	PL49D	6		PL62D	6	
AC28	PL51A	6		PL65A	6	
AD28	PL51B	6		PL65B	6	
AB26	PL51C	6		PL65C	6	
AC26	PL51D	6	VREF2_6	PL65D	6	VREF2_6
AC32	PL52A	6		PL66A	6	
AD32	PL52B	6		PL66B	6	
AA24	PL52C	6		PL66C	6	
AA23	PL52D	6		PL66D	6	
AE30	PL53A	6		PL67A	6	
AE29	PL53B	6		PL67B	6	
AC25	PL53C	6		PL67C	6	
AB25	PL53D	6		PL67D	6	
AE31	PL55A	6		PL69A	6	
AE32	PL55B	6		PL69B	6	
AE26	PL55C	6	LLC_DLLT_IN_E/LLC_DLLT_FB_F	PL69C	6	LLC_DLLT_IN_E/LLC_DLLT_FB_F
AE27	PL55D	6	LLC_DLLC_IN_E/LLC_DLLC_FB_F	PL69D	6	LLC_DLLC_IN_E/LLC_DLLC_FB_F
AF32	PL56A	6		PL70A	6	
AF31	PL56B	6		PL70B	6	
AC24	PL56C	6		PL70C	6	
AD25	PL56D	6		PL70D	6	
AG32	PL57A	6	LLC_DLLT_IN_F/LLC_DLLT_FB_E	PL71A	6	LLC_DLLT_IN_F/LLC_DLLT_FB_E
AG31	PL57B	6	LLC_DLLC_IN_F/LLC_DLLC_FB_E	PL71B	6	LLC_DLLC_IN_F/LLC_DLLC_FB_E
AC23	PL57C	6	LLC_PLLT_IN_B/LLC_PLLT_FB_A	PL71C	6	LLC_PLLT_IN_B/LLC_PLLT_FB_A
AD24	PL57D	6	LLC_PLLC_IN_B/LLC_PLLC_FB_A	PL71D	6	LLC_PLLC_IN_B/LLC_PLLC_FB_A
AH32	XRES	-		XRES	-	
AH31	TEMP	6		TEMP	6	
AJ32	PB3A	5	LLC_PLLT_IN_A/LLC_PLLT_FB_B	PB3A	5	LLC_PLLT_IN_A/LLC_PLLT_FB_B
AK32	PB3B	5	LLC_PLLC_IN_A/LLC_PLLC_FB_B	PB3B	5	LLC_PLLC_IN_A/LLC_PLLC_FB_B
AF27	PB3C	5	LLC_DLLT_IN_C/LLC_DLLT_FB_D	PB3C	5	LLC_DLLT_IN_C/LLC_DLLT_FB_D
AG28	PB3D	5	LLC_DLLC_IN_C/LLC_DLLC_FB_D	PB3D	5	LLC_DLLC_IN_C/LLC_DLLC_FB_D
AK31	PB4A	5	LLC_DLLT_IN_D/LLC_DLLT_FB_C	PB4A	5	LLC_DLLT_IN_D/LLC_DLLT_FB_C
AL31	PB4B	5	LLC_DLLC_IN_D/LLC_DLLC_FB_C	PB4B	5	LLC_DLLC_IN_D/LLC_DLLC_FB_C
AE25	PB4C	5		PB4C	5	
AE24	PB4D	5		PB4D	5	
AK30	PB5A	5		PB5A	5	
AL30	PB5B	5		PB5B	5	
AD23	PB5C	5		PB5C	5	
AE23	PB5D	5	VREF1_5	PB5D	5	VREF1_5
AK29	PB7A	5		PB7A	5	
AL29	PB7B	5		PB7B	5	
AF26	PB7C	5		PB7C	5	
AF25	PB7D	5		PB7D	5	
AJ28	PB8A	5		PB8A	5	
AK28	PB8B	5		PB8B	5	

LFSC/M25, LFSC/M40 Logic Signal Connections: 1020 fcBGA^{1,2} (Cont.)

Ball Number	LFSC/M25			LFSC/M40		
	Ball Function	VCCIO Bank	Dual Function	Ball Function	VCCIO Bank	Dual Function
AJ31	PB9A	5		PB9A	5	
AH30	PB9B	5		PB9B	5	
AM30	PB11A	5		PB11A	5	
AM29	PB11B	5		PB11B	5	
AH29	PB11C	5		PB11C	5	
AH28	PB11D	5		PB11D	5	
AJ27	PB12A	5		PB13A	5	
AK27	PB12B	5		PB13B	5	
AE22	PB12C	5		PB13C	5	
AF23	PB12D	5		PB13D	5	
AL28	PB13A	5		PB15A	5	
AL27	PB13B	5		PB15B	5	
AC21	PB13C	5		PB15C	5	
AD21	PB13D	5		PB15D	5	
AM28	PB15A	5		PB17A	5	
AM27	PB15B	5		PB17B	5	
AG23	PB15C	5		PB17C	5	
AF22	PB15D	5		PB17D	5	
AG26	PB16A	5		PB19A	5	
AG25	PB16B	5		PB19B	5	
AL26	PB17A	5		PB22A	5	
AM26	PB17B	5		PB22B	5	
AJ24	PB19A	5		PB25A	5	
AK24	PB19B	5		PB25B	5	
AE21	PB19C	5		PB25C	5	
AE20	PB19D	5		PB25D	5	
AJ22	PB20A	5	PCLKT5_3	PB30A	5	PCLKT5_3
AK22	PB20B	5	PCLKC5_3	PB30B	5	PCLKC5_3
AG22	PB20C	5	PCLKT5_4	PB30C	5	PCLKT5_4
AH22	PB20D	5	PCLKC5_4	PB30D	5	PCLKC5_4
AL23	PB21A	5	PCLKT5_5	PB31A	5	PCLKT5_5
AL22	PB21B	5	PCLKC5_5	PB31B	5	PCLKC5_5
AH23	PB21C	5		PB31C	5	
AH24	PB21D	5		PB31D	5	
AJ21	PB23A	5	PCLKT5_0	PB33A	5	PCLKT5_0
AK21	PB23B	5	PCLKC5_0	PB33B	5	PCLKC5_0
AE19	PB23C	5		PB33C	5	
AF19	PB23D	5	VREF2_5	PB33D	5	VREF2_5
AM23	PB24A	5	PCLKT5_1	PB34A	5	PCLKT5_1
AM22	PB24B	5	PCLKC5_1	PB34B	5	PCLKC5_1
AH25	PB24C	5	PCLKT5_6	PB34C	5	PCLKT5_6
AH26	PB24D	5	PCLKC5_6	PB34D	5	PCLKC5_6
AL21	PB25A	5	PCLKT5_2	PB35A	5	PCLKT5_2
AL20	PB25B	5	PCLKC5_2	PB35B	5	PCLKC5_2
AG20	PB25C	5	PCLKT5_7	PB35C	5	PCLKT5_7
AG19	PB25D	5	PCLKC5_7	PB35D	5	PCLKC5_7
AJ19	PB28A	5		PB37A	5	
AK19	PB28B	5		PB37B	5	
AD18	PB28C	5		PB37C	5	
AE18	PB28D	5		PB37D	5	

LFSC/M25, LFSC/M40 Logic Signal Connections: 1020 fcBGA^{1,2} (Cont.)

Ball Number	LFSC/M25			LFSC/M40		
	Ball Function	VCCIO Bank	Dual Function	Ball Function	VCCIO Bank	Dual Function
AM21	PB29A	5		PB38A	5	
AM20	PB29B	5		PB38B	5	
AH21	PB29C	5		PB38C	5	
AH20	PB29D	5		PB38D	5	
AJ18	PB31A	5		PB39A	5	
AK18	PB31B	5		PB39B	5	
AH19	PB31C	5		PB39C	5	
AH18	PB31D	5		PB39D	5	
AL19	PB32A	5		PB41A	5	
AM19	PB32B	5		PB41B	5	
AH17	PB32C	5		PB41C	5	
AG17	PB32D	5		PB41D	5	
AL18	PB33A	5		PB42A	5	
AM18	PB33B	5		PB42B	5	
AC17	PB33C	5		PB42C	5	
AD17	PB33D	5		PB42D	5	
AL17	PB35A	5		PB43A	5	
AM17	PB35B	5		PB43B	5	
AE17	PB35C	5		PB43C	5	
AF17	PB35D	5		PB43D	5	
AM16	PB37A	4		PB45A	4	
AL16	PB37B	4		PB45B	4	
AF16	PB37C	4		PB45C	4	
AE16	PB37D	4		PB45D	4	
AM15	PB38A	4		PB46A	4	
AL15	PB38B	4		PB46B	4	
AD16	PB38C	4		PB46C	4	
AC16	PB38D	4		PB46D	4	
AM14	PB39A	4		PB47A	4	
AL14	PB39B	4		PB47B	4	
AG16	PB39C	4		PB47C	4	
AH16	PB39D	4		PB47D	4	
AK15	PB41A	4		PB49A	4	
AJ15	PB41B	4		PB49B	4	
AH15	PB41C	4		PB49C	4	
AH14	PB41D	4		PB49D	4	
AM13	PB42A	4		PB50A	4	
AM12	PB42B	4		PB50B	4	
AH13	PB42C	4		PB50C	4	
AH12	PB42D	4		PB50D	4	
AK14	PB43A	4		PB51A	4	
AJ14	PB43B	4		PB51B	4	
AE15	PB43C	4		PB51C	4	
AD15	PB43D	4		PB51D	4	
AL13	PB46A	4	PCLKT4_2	PB53A	4	PCLKT4_2
AL12	PB46B	4	PCLKC4_2	PB53B	4	PCLKC4_2
AG14	PB46C	4	PCLKT4_7	PB53C	4	PCLKT4_7
AG13	PB46D	4	PCLKC4_7	PB53D	4	PCLKC4_7
AM11	PB47A	4	PCLKT4_1	PB54A	4	PCLKT4_1
AM10	PB47B	4	PCLKC4_1	PB54B	4	PCLKC4_1

LFSC/M25, LFSC/M40 Logic Signal Connections: 1020 fcBGA^{1,2} (Cont.)

Ball Number	LFSC/M25			LFSC/M40		
	Ball Function	VCCIO Bank	Dual Function	Ball Function	VCCIO Bank	Dual Function
AH11	PB47C	4	PCLKT4_6	PB54C	4	PCLKT4_6
AH10	PB47D	4	PCLKC4_6	PB54D	4	PCLKC4_6
AK12	PB49A	4	PCLKT4_0	PB55A	4	PCLKT4_0
AJ12	PB49B	4	PCLKC4_0	PB55B	4	PCLKC4_0
AF14	PB49C	4	VREF2_4	PB55C	4	VREF2_4
AE14	PB49D	4		PB55D	4	
AL11	PB51A	4	PCLKT4_5	PB57A	4	PCLKT4_5
AL10	PB51B	4	PCLKC4_5	PB57B	4	PCLKC4_5
AH9	PB51C	4		PB57C	4	
AH8	PB51D	4		PB57D	4	
AK11	PB52A	4	PCLKT4_3	PB58A	4	PCLKT4_3
AJ11	PB52B	4	PCLKC4_3	PB58B	4	PCLKC4_3
AH7	PB52C	4	PCLKT4_4	PB58C	4	PCLKT4_4
AH6	PB52D	4	PCLKC4_4	PB58D	4	PCLKC4_4
AK8	PB53A	4		PB67A	4	
AJ8	PB53B	4		PB67B	4	
AF11	PB53C	4		PB67C	4	
AD12	PB55A	4		PB69A	4	
AE12	PB55B	4		PB69B	4	
AM6	PB56A	4		PB70A	4	
AM5	PB56B	4		PB70B	4	
AC12	PB56C	4		PB70C	4	
AL6	PB57A	4		PB73A	4	
AL5	PB57B	4		PB73B	4	
AG7	PB59A	4		PB74A	4	
AG8	PB59B	4		PB74B	4	
AK6	PB60A	4		PB75A	4	
AJ6	PB60B	4		PB75B	4	
AF10	PB60C	4		PB75C	4	
AE11	PB60D	4		PB75D	4	
AM4	PB61A	4		PB77A	4	
AM3	PB61B	4		PB77B	4	
AH5	PB63A	4		PB78A	4	
AH4	PB63B	4		PB78B	4	
AK5	PB64A	4		PB79A	4	
AJ5	PB64B	4		PB79B	4	
AF8	PB64C	4		PB79C	4	
AF7	PB64D	4		PB79D	4	
AL4	PB65A	4		PB81A	4	
AL3	PB65B	4		PB81B	4	
AG5	PB65C	4		PB81C	4	
AF6	PB65D	4		PB81D	4	
AK3	PB67A	4		PB82A	4	
AJ3	PB67B	4		PB82B	4	
AE10	PB67C	4	VREF1_4	PB82C	4	VREF1_4
AD10	PB67D	4		PB82D	4	
AL2	PB68A	4	LRC_DLLT_IN_C/LRC_DLLT_FB_D	PB83A	4	LRC_DLLT_IN_C/LRC_DLLT_FB_D
AK2	PB68B	4	LRC_DLLC_IN_C/LRC_DLLC_FB_D	PB83B	4	LRC_DLLC_IN_C/LRC_DLLC_FB_D
AE9	PB68C	4		PB83C	4	
AE8	PB68D	4		PB83D	4	

LFSC/M25, LFSC/M40 Logic Signal Connections: 1020 fcBGA^{1,2} (Cont.)

Ball Number	LFSC/M25			LFSC/M40		
	Ball Function	VCCIO Bank	Dual Function	Ball Function	VCCIO Bank	Dual Function
AJ1	PB69A	4	LRC_PLLT_IN_A/LRC_PLLT_FB_B	PB85A	4	LRC_PLLT_IN_A/LRC_PLLT_FB_B
AK1	PB69B	4	LRC_PLLC_IN_A/LRC_PLLC_FB_B	PB85B	4	LRC_PLLC_IN_A/LRC_PLLC_FB_B
AJ2	PB69C	4	LRC_DLLT_IN_D/LRC_DLLT_FB_C	PB85C	4	LRC_DLLT_IN_D/LRC_DLLT_FB_C
AH3	PB69D	4	LRC_DLLC_IN_D/LRC_DLLC_FB_C	PB85D	4	LRC_DLLC_IN_D/LRC_DLLC_FB_C
AH1	PROBE_VCC	-		PROBE_VCC	-	
AH2	PROBE_GND	-		PROBE_GND	-	
AD9	PR57D	3	LRC_PLLC_IN_B/LRC_PLLC_FB_A	PR71D	3	LRC_PLLC_IN_B/LRC_PLLC_FB_A
AC10	PR57C	3	LRC_PLLT_IN_B/LRC_PLLT_FB_A	PR71C	3	LRC_PLLT_IN_B/LRC_PLLT_FB_A
AG2	PR57B	3	LRC_DLLC_IN_F/LRC_DLLC_FB_E	PR71B	3	LRC_DLLC_IN_F/LRC_DLLC_FB_E
AG1	PR57A	3	LRC_DLLT_IN_F/LRC_DLLT_FB_E	PR71A	3	LRC_DLLT_IN_F/LRC_DLLT_FB_E
AD8	PR56D	3		PR70D	3	
AC9	PR56C	3		PR70C	3	
AF2	PR56B	3		PR70B	3	
AF1	PR56A	3		PR70A	3	
AE6	PR55D	3	LRC_DLLC_IN_E/LRC_DLLC_FB_F	PR69D	3	LRC_DLLC_IN_E/LRC_DLLC_FB_F
AE7	PR55C	3	LRC_DLLT_IN_E/LRC_DLLT_FB_F	PR69C	3	LRC_DLLT_IN_E/LRC_DLLT_FB_F
AE1	PR55B	3		PR69B	3	
AE2	PR55A	3		PR69A	3	
AB8	PR53D	3		PR67D	3	
AC8	PR53C	3		PR67C	3	
AE4	PR53B	3		PR67B	3	
AE3	PR53A	3		PR67A	3	
AA10	PR52D	3		PR66D	3	
AA9	PR52C	3		PR66C	3	
AD1	PR52B	3		PR66B	3	
AC1	PR52A	3		PR66A	3	
AC7	PR51D	3	VREF2_3	PR65D	3	VREF2_3
AB7	PR51C	3		PR65C	3	
AD5	PR51B	3		PR65B	3	
AC5	PR51A	3		PR65A	3	
AE5	PR49D	3		PR62D	3	
AF5	PR49C	3		PR62C	3	
AD3	PR49B	3		PR62B	3	
AD4	PR49A	3		PR62A	3	
Y10	PR48D	3		PR61D	3	
Y9	PR48C	3		PR61C	3	
AC2	PR48B	3		PR61B	3	
AD2	PR48A	3		PR61A	3	
AC6	PR47D	3		PR60D	3	
AB6	PR47C	3		PR60C	3	
AA1	PR47B	3		PR60B	3	
AB1	PR47A	3		PR60A	3	
AA5	PR44D	3		PR53D	3	
AB5	PR44C	3		PR53C	3	
Y1	PR44B	3		PR53B	3	
W1	PR44A	3		PR53A	3	
W8	PR43D	3		PR52D	3	
Y7	PR43C	3		PR52C	3	
Y5	PR43B	3		PR52B	3	
W5	PR43A	3		PR52A	3	

LFSC/M25, LFSC/M40 Logic Signal Connections: 1020 fcBGA^{1,2} (Cont.)

Ball Number	LFSC/M25			LFSC/M40		
	Ball Function	VCCIO Bank	Dual Function	Ball Function	VCCIO Bank	Dual Function
Y6	PR42D	3	DIFFR_3	PR51D	3	DIFFR_3
W6	PR42C	3		PR51C	3	
Y2	PR42B	3		PR51B	3	
W2	PR42A	3		PR51A	3	
W7	PR40D	3		PR49D	3	
V8	PR40C	3		PR49C	3	
W4	PR40B	3		PR49B	3	
W3	PR40A	3		PR49A	3	
V5	PR39D	3		PR48D	3	
U6	PR39C	3		PR48C	3	
V3	PR39B	3		PR48B	3	
V4	PR39A	3		PR48A	3	
V10	PR38D	3		PR47D	3	
V9	PR38C	3		PR47C	3	
V2	PR38B	3		PR47B	3	
V1	PR38A	3		PR47A	3	
U8	PR36D	3		PR45D	3	
U7	PR36C	3		PR45C	3	
U2	PR36B	3		PR45B	3	
U1	PR36A	3		PR45A	3	
U5	PR35D	3		PR44D	3	
T6	PR35C	3		PR44C	3	
T1	PR35B	3		PR44B	3	
T2	PR35A	3		PR44A	3	
U9	PR34D	3		PR43D	3	
U10	PR34C	3	VREF1_3	PR43C	3	VREF1_3
R1	PR34B	3		PR43B	3	
R2	PR34A	3		PR43A	3	
T7	PR31D	3	PCLKC3_2	PR40D	3	PCLKC3_2
T8	PR31C	3	PCLKT3_2	PR40C	3	PCLKT3_2
R4	PR31B	3		PR40B	3	
R3	PR31A	3		PR40A	3	
T5	PR30D	3	PCLKC3_3	PR39D	3	PCLKC3_3
R5	PR30C	3	PCLKT3_3	PR39C	3	PCLKT3_3
P2	PR30B	3		PR39B	3	
P1	PR30A	3		PR39A	3	
T9	PR29D	3	PCLKC3_1	PR38D	3	PCLKC3_1
T10	PR29C	3	PCLKT3_1	PR38C	3	PCLKT3_1
P4	PR29B	3	PCLKC3_0	PR38B	3	PCLKC3_0
P3	PR29A	3	PCLKT3_0	PR38A	3	PCLKT3_0
P5	PR27D	2	PCLKC2_2	PR36D	2	PCLKC2_2
P6	PR27C	2	PCLKT2_2	PR36C	2	PCLKT2_2
N1	PR27B	2	PCLKC2_0	PR36B	2	PCLKC2_0
N2	PR27A	2	PCLKT2_0	PR36A	2	PCLKT2_0
R9	PR26D	2	PCLKC2_3	PR35D	2	PCLKC2_3
R8	PR26C	2	PCLKT2_3	PR35C	2	PCLKT2_3
M1	PR26B	2	PCLKC2_1	PR35B	2	PCLKC2_1
L1	PR26A	2	PCLKT2_1	PR35A	2	PCLKT2_1
N9	PR25D	2	DIFFR_2	PR23D	2	DIFFR_2
M9	PR25C	2	VREF1_2	PR23C	2	VREF1_2

LFSC/M25, LFSC/M40 Logic Signal Connections: 1020 fcBGA^{1,2} (Cont.)

Ball Number	LFSC/M25			LFSC/M40		
	Ball Function	VCCIO Bank	Dual Function	Ball Function	VCCIO Bank	Dual Function
H1	PR25B	2		PR23B	2	
H2	PR25A	2		PR23A	2	
N8	PR22D	2		PR25D	2	
M8	PR22C	2		PR25C	2	
H4	PR22B	2		PR25B	2	
J4	PR22A	2		PR25A	2	
G1	PR21B	2		PR22B	2	
G2	PR21A	2		PR22A	2	
L7	PR20D	2		PR21D	2	
L8	PR20C	2		PR21C	2	
F2	PR20B	2		PR21B	2	
F1	PR20A	2		PR21A	2	
K5	PR18D	2	VREF2_2	PR18D	2	VREF2_2
J5	PR18C	2		PR18C	2	
E2	PR18B	2	URC_DLLC_IN_D/URC_DLLC_FB_C	PR18B	2	URC_DLLC_IN_D/URC_DLLC_FB_C
E1	PR18A	2	URC_DLLT_IN_D/URC_DLLT_FB_C	PR18A	2	URC_DLLT_IN_D/URC_DLLT_FB_C
N10	PR17D	2	URC_PLLC_IN_B/URC_PLLC_FB_A	PR17D	2	URC_PLLC_IN_B/URC_PLLC_FB_A
M10	PR17C	2	URC_PLLT_IN_B/URC_PLLT_FB_A	PR17C	2	URC_PLLT_IN_B/URC_PLLT_FB_A
D2	PR17B	2	URC_DLLC_IN_C/URC_DLLC_FB_D	PR17B	2	URC_DLLC_IN_C/URC_DLLC_FB_D
D1	PR17A	2	URC_DLLT_IN_C/URC_DLLT_FB_D	PR17A	2	URC_DLLT_IN_C/URC_DLLT_FB_D
K6	PR16D	2		PR16D	2	
K7	PR16C	2		PR16C	2	
J8	PR16B	2	URC_PLLC_IN_A/URC_PLLC_FB_B	PR16B	2	URC_PLLC_IN_A/URC_PLLC_FB_B
K8	PR16A	2	URC_PLLT_IN_A/URC_PLLT_FB_B	PR16A	2	URC_PLLT_IN_A/URC_PLLT_FB_B
J10	VCCJ	-		VCCJ	-	
J9	TDO	-	TDO	TDO	-	TDO
K9	TMS	-		TMS	-	
J12	TCK	-		TCK	-	
J13	TDI	-		TDI	-	
K12	PROGRAMN	1		PROGRAMN	1	
K13	MPIIRQN	1	CFGIRQN/MPI_IRQ_N	MPIIRQN	1	CFGIRQN/MPI_IRQ_N
K10	CCLK	1		CCLK	1	
F5	RESP_URC	-		RESP_URC	-	
B5	VCC12	-		VCC12	-	
D5	A_REFCLKN_R	-		A_REFCLKN_R	-	
C5	A_REFCLKP_R	-		A_REFCLKP_R	-	
B2	A_VDDIB0_R	-		A_VDDIB0_R	-	
C1	A_HDINP0_R	-	PCS 3E0 CH 0 IN P	A_HDINP0_R	-	PCS 3E0 CH 0 IN P
C2	A_HDINN0_R	-	PCS 3E0 CH 0 IN N	A_HDINN0_R	-	PCS 3E0 CH 0 IN N
A3	A_HDOUTP0_R	-	PCS 3E0 CH 0 OUT P	A_HDOUTP0_R	-	PCS 3E0 CH 0 OUT P
D3	A_VDDOB0_R	-		A_VDDOB0_R	-	
B3	A_HDOUTN0_R	-	PCS 3E0 CH 0 OUT N	A_HDOUTN0_R	-	PCS 3E0 CH 0 OUT N
D4	A_VDDOB1_R	-		A_VDDOB1_R	-	
B4	A_HDOUTN1_R	-	PCS 3E0 CH 1 OUT N	A_HDOUTN1_R	-	PCS 3E0 CH 1 OUT N
A4	A_HDOUTP1_R	-	PCS 3E0 CH 1 OUT P	A_HDOUTP1_R	-	PCS 3E0 CH 1 OUT P
H5	A_HDINN1_R	-	PCS 3E0 CH 1 IN N	A_HDINN1_R	-	PCS 3E0 CH 1 IN N
G5	A_HDINP1_R	-	PCS 3E0 CH 1 IN P	A_HDINP1_R	-	PCS 3E0 CH 1 IN P
F4	A_VDDIB1_R	-		A_VDDIB1_R	-	
H6	A_VDDIB2_R	-		A_VDDIB2_R	-	
F6	A_HDINP2_R	-	PCS 3E0 CH 2 IN P	A_HDINP2_R	-	PCS 3E0 CH 2 IN P

LFSC/M25, LFSC/M40 Logic Signal Connections: 1020 fcBGA^{1,2} (Cont.)

Ball Number	LFSC/M25			LFSC/M40		
	Ball Function	VCCIO Bank	Dual Function	Ball Function	VCCIO Bank	Dual Function
G6	A_HDINN2_R	-	PCS 3E0 CH 2 IN N	A_HDINN2_R	-	PCS 3E0 CH 2 IN N
A6	A_HDOUTP2_R	-	PCS 3E0 CH 2 OUT P	A_HDOUTP2_R	-	PCS 3E0 CH 2 OUT P
D6	A_VDDOB2_R	-		A_VDDOB2_R	-	
B6	A_HDOUTN2_R	-	PCS 3E0 CH 2 OUT N	A_HDOUTN2_R	-	PCS 3E0 CH 2 OUT N
D7	A_VDDOB3_R	-		A_VDDOB3_R	-	
B7	A_HDOUTN3_R	-	PCS 3E0 CH 3 OUT N	A_HDOUTN3_R	-	PCS 3E0 CH 3 OUT N
A7	A_HDOUTP3_R	-	PCS 3E0 CH 3 OUT P	A_HDOUTP3_R	-	PCS 3E0 CH 3 OUT P
G7	A_HDINN3_R	-	PCS 3E0 CH 3 IN N	A_HDINN3_R	-	PCS 3E0 CH 3 IN N
F7	A_HDINP3_R	-	PCS 3E0 CH 3 IN P	A_HDINP3_R	-	PCS 3E0 CH 3 IN P
H7	A_VDDIB3_R	-		A_VDDIB3_R	-	
H8	B_VDDIB0_R	-		B_VDDIB0_R	-	
F8	B_HDINP0_R	-	PCS 3E1 CH 0 IN P	B_HDINP0_R	-	PCS 3E1 CH 0 IN P
G8	B_HDINN0_R	-	PCS 3E1 CH 0 IN N	B_HDINN0_R	-	PCS 3E1 CH 0 IN N
A8	B_HDOUTP0_R	-	PCS 3E1 CH 0 OUT P	B_HDOUTP0_R	-	PCS 3E1 CH 0 OUT P
D8	B_VDDOB0_R	-		B_VDDOB0_R	-	
B8	B_HDOUTN0_R	-	PCS 3E1 CH 0 OUT N	B_HDOUTN0_R	-	PCS 3E1 CH 0 OUT N
D9	B_VDDOB1_R	-		B_VDDOB1_R	-	
B9	B_HDOUTN1_R	-	PCS 3E1 CH 1 OUT N	B_HDOUTN1_R	-	PCS 3E1 CH 1 OUT N
A9	B_HDOUTP1_R	-	PCS 3E1 CH 1 OUT P	B_HDOUTP1_R	-	PCS 3E1 CH 1 OUT P
H10	B_HDINN1_R	-	PCS 3E1 CH 1 IN N	B_HDINN1_R	-	PCS 3E1 CH 1 IN N
G10	B_HDINP1_R	-	PCS 3E1 CH 1 IN P	B_HDINP1_R	-	PCS 3E1 CH 1 IN P
H9	B_VDDIB1_R	-		B_VDDIB1_R	-	
H11	B_VDDIB2_R	-		B_VDDIB2_R	-	
F11	B_HDINP2_R	-	PCS 3E1 CH 2 IN P	B_HDINP2_R	-	PCS 3E1 CH 2 IN P
G11	B_HDINN2_R	-	PCS 3E1 CH 2 IN N	B_HDINN2_R	-	PCS 3E1 CH 2 IN N
A11	B_HDOUTP2_R	-	PCS 3E1 CH 2 OUT P	B_HDOUTP2_R	-	PCS 3E1 CH 2 OUT P
D11	B_VDDOB2_R	-		B_VDDOB2_R	-	
B11	B_HDOUTN2_R	-	PCS 3E1 CH 2 OUT N	B_HDOUTN2_R	-	PCS 3E1 CH 2 OUT N
D12	B_VDDOB3_R	-		B_VDDOB3_R	-	
B12	B_HDOUTN3_R	-	PCS 3E1 CH 3 OUT N	B_HDOUTN3_R	-	PCS 3E1 CH 3 OUT N
A12	B_HDOUTP3_R	-	PCS 3E1 CH 3 OUT P	B_HDOUTP3_R	-	PCS 3E1 CH 3 OUT P
G12	B_HDINN3_R	-	PCS 3E1 CH 3 IN N	B_HDINN3_R	-	PCS 3E1 CH 3 IN N
F12	B_HDINP3_R	-	PCS 3E1 CH 3 IN P	B_HDINP3_R	-	PCS 3E1 CH 3 IN P
H12	B_VDDIB3_R	-		B_VDDIB3_R	-	
B10	VCC12	-		VCC12	-	
D10	B_REFCLKN_R	-		B_REFCLKN_R	-	
C10	B_REFCLKP_R	-		B_REFCLKP_R	-	
J15	PT49D	1	HDC/SI	PT61D	1	HDC/SI
K15	PT49C	1	LDCN/SCS	PT61C	1	LDCN/SCS
E13	PT49B	1	D8/MPI_DATA8	PT59B	1	D8/MPI_DATA8
F13	PT49A	1	CS1/MPI_CS1	PT59A	1	CS1/MPI_CS1
H13	PT47D	1	D9/MPI_DATA9	PT58D	1	D9/MPI_DATA9
G13	PT47C	1	D10/MPI_DATA10	PT58C	1	D10/MPI_DATA10
E14	PT47B	1	CS0N/MPI_CS0N	PT57B	1	CS0N/MPI_CS0N
F14	PT47A	1	RDN/MPI_STRB_N	PT57A	1	RDN/MPI_STRB_N
H14	PT46D	1	WRN/MPI_WR_N	PT55D	1	WRN/MPI_WR_N
G14	PT46C	1	D7/MPI_DATA7	PT55C	1	D7/MPI_DATA7
D13	PT46B	1	D6/MPI_DATA6	PT55B	1	D6/MPI_DATA6
D14	PT46A	1	D5/MPI_DATA5	PT55A	1	D5/MPI_DATA5
E15	PT45D	1	D4/MPI_DATA4	PT54D	1	D4/MPI_DATA4

LFSC/M25, LFSC/M40 Logic Signal Connections: 1020 fcBGA^{1,2} (Cont.)

Ball Number	LFSC/M25			LFSC/M40		
	Ball Function	VCCIO Bank	Dual Function	Ball Function	VCCIO Bank	Dual Function
E16	PT45C	1	D3/MPI_DATA3	PT54C	1	D3/MPI_DATA3
C13	PT45B	1	D2/MPI_DATA2	PT53B	1	D2/MPI_DATA2
C14	PT45A	1	D1/MPI_DATA1	PT53A	1	D1/MPI_DATA1
B14	PT43B	1	D0/MPI_DATA0	PT51B	1	D0/MPI_DATA0
B13	PT43A	1	QOUT/CEON	PT51A	1	QOUT/CEON
L13	PT42D	1	VREF2_1	PT50D	1	VREF2_1
C15	PT42B	1	DOUT	PT50B	1	DOUT
D15	PT42A	1	MCA_DONE_IN	PT50A	1	MCA_DONE_IN
J16	PT41B	1	MCA_CLK_P1_OUT	PT49B	1	MCA_CLK_P1_OUT
K16	PT41A	1	MCA_CLK_P1_IN	PT49A	1	MCA_CLK_P1_IN
H15	PT39D	1	D21/PCLKC1_1/MPI_DATA21	PT47D	1	D21/PCLKC1_1/MPI_DATA21
H16	PT39C	1	D22/PCLKT1_1/MPI_DATA22	PT47C	1	D22/PCLKT1_1/MPI_DATA22
A14	PT39B	1	MCA_CLK_P2_OUT	PT47B	1	MCA_CLK_P2_OUT
A13	PT39A	1	MCA_CLK_P2_IN	PT47A	1	MCA_CLK_P2_IN
G16	PT38D	1	MCA_DONE_OUT	PT46D	1	MCA_DONE_OUT
F16	PT38C	1	BUSYN/RCLK/SCK	PT46C	1	BUSYN/RCLK/SCK
B16	PT38B	1	DP0/MPI_PAR0	PT46B	1	DP0/MPI_PAR0
B15	PT38A	1	MPI_TA	PT46A	1	MPI_TA
L16	PT37C	1	DP2/MPI_PAR2	PT45C	1	DP2/MPI_PAR2
A16	PT37B	1	PCLKC1_0	PT45B	1	PCLKC1_0
A15	PT37A	1	PCLKT1_0/MPI_CLK	PT45A	1	PCLKT1_0/MPI_CLK
L17	PT35C	1	D24/PCLKT1_4/MPI_DATA24	PT43C	1	D24/PCLKT1_4/MPI_DATA24
A17	PT35B	1	MPI_RETRY	PT43B	1	MPI_RETRY
A18	PT35A	1	A0/MPI_ADDR14	PT43A	1	A0/MPI_ADDR14
F17	PT33D	1	A1/MPI_ADDR15	PT42D	1	A1/MPI_ADDR15
G17	PT33C	1	A2/MPI_ADDR16	PT42C	1	A2/MPI_ADDR16
B17	PT33B	1	A3/MPI_ADDR17	PT42B	1	A3/MPI_ADDR17
B18	PT33A	1	A4/MPI_ADDR18	PT42A	1	A4/MPI_ADDR18
H17	PT32D	1	D25/PCLKC1_5/MPI_DATA25	PT41D	1	D25/PCLKC1_5/MPI_DATA25
H18	PT32C	1	D26/PCLKT1_5/MPI_DATA26	PT41C	1	D26/PCLKT1_5/MPI_DATA26
A19	PT32B	1	A5/MPI_ADDR19	PT41B	1	A5/MPI_ADDR19
A20	PT32A	1	A6/MPI_ADDR20	PT41A	1	A6/MPI_ADDR20
L20	PT31C	1	VREF1_1	PT39C	1	VREF1_1
J17	PT31B	1	A7/MPI_ADDR21	PT39B	1	A7/MPI_ADDR21
K17	PT31A	1	A8/MPI_ADDR22	PT39A	1	A8/MPI_ADDR22
C18	PT29B	1	A9/MPI_ADDR23	PT38B	1	A9/MPI_ADDR23
D18	PT29A	1	A10/MPI_ADDR24	PT38A	1	A10/MPI_ADDR24
B19	PT28B	1	A11/MPI_ADDR25	PT37B	1	A11/MPI_ADDR25
B20	PT28A	1	A12/MPI_ADDR26	PT37A	1	A12/MPI_ADDR26
E17	PT27D	1	D11/MPI_DATA11	PT35D	1	D11/MPI_DATA11
E18	PT27C	1	D12/MPI_DATA12	PT35C	1	D12/MPI_DATA12
C20	PT27B	1	A13/MPI_ADDR27	PT35B	1	A13/MPI_ADDR27
C19	PT27A	1	A14/MPI_ADDR28	PT35A	1	A14/MPI_ADDR28
H19	PT25D	1	A16/MPI_ADDR30	PT33D	1	A16/MPI_ADDR30
G19	PT25C	1	D13/MPI_DATA13	PT33C	1	D13/MPI_DATA13
D20	PT25B	1	A15/MPI_ADDR29	PT33B	1	A15/MPI_ADDR29
D19	PT25A	1	A17/MPI_ADDR31	PT33A	1	A17/MPI_ADDR31
H20	PT24D	1	A19/MPI_TSIZ1	PT30D	1	A19/MPI_TSIZ1
G20	PT24C	1	A20/MPI_BDIP	PT30C	1	A20/MPI_BDIP
E19	PT24B	1	A18/MPI_TSIZ0	PT30B	1	A18/MPI_TSIZ0

LFSC/M25, LFSC/M40 Logic Signal Connections: 1020 fcBGA^{1,2} (Cont.)

Ball Number	LFSC/M25			LFSC/M40		
	Ball Function	VCCIO Bank	Dual Function	Ball Function	VCCIO Bank	Dual Function
F19	PT24A	1	MPI_TEA	PT30A	1	MPI_TEA
J18	PT23D	1	D14/MPI_DATA14	PT28D	1	D14/MPI_DATA14
K18	PT23C	1	DP1/MPI_PAR1	PT28C	1	DP1/MPI_PAR1
E20	PT23B	1	A21/MPI_BURST	PT27B	1	A21/MPI_BURST
F20	PT23A	1	D15/MPI_DATA15	PT27A	1	D15/MPI_DATA15
C23	B_REFCLKP_L	-		B_REFCLKP_L	-	
D23	B_REFCLKN_L	-		B_REFCLKN_L	-	
B23	VCC12	-		VCC12	-	
H21	B_VDDIB3_L	-		B_VDDIB3_L	-	
F21	B_HDINP3_L	-	PCS 361 CH 3 IN P	B_HDINP3_L	-	PCS 361 CH 3 IN P
G21	B_HDINN3_L	-	PCS 361 CH 3 IN N	B_HDINN3_L	-	PCS 361 CH 3 IN N
A21	B_HDOUTP3_L	-	PCS 361 CH 3 OUT P	B_HDOUTP3_L	-	PCS 361 CH 3 OUT P
B21	B_HDOUTN3_L	-	PCS 361 CH 3 OUT N	B_HDOUTN3_L	-	PCS 361 CH 3 OUT N
D21	B_VDDOB3_L	-		B_VDDOB3_L	-	
B22	B_HDOUTN2_L	-	PCS 361 CH 2 OUT N	B_HDOUTN2_L	-	PCS 361 CH 2 OUT N
D22	B_VDDOB2_L	-		B_VDDOB2_L	-	
A22	B_HDOUTP2_L	-	PCS 361 CH 2 OUT P	B_HDOUTP2_L	-	PCS 361 CH 2 OUT P
G22	B_HDINN2_L	-	PCS 361 CH 2 IN N	B_HDINN2_L	-	PCS 361 CH 2 IN N
F22	B_HDINP2_L	-	PCS 361 CH 2 IN P	B_HDINP2_L	-	PCS 361 CH 2 IN P
H22	B_VDDIB2_L	-		B_VDDIB2_L	-	
H24	B_VDDIB1_L	-		B_VDDIB1_L	-	
G23	B_HDINP1_L	-	PCS 361 CH 1 IN P	B_HDINP1_L	-	PCS 361 CH 1 IN P
H23	B_HDINN1_L	-	PCS 361 CH 1 IN N	B_HDINN1_L	-	PCS 361 CH 1 IN N
A24	B_HDOUTP1_L	-	PCS 361 CH 1 OUT P	B_HDOUTP1_L	-	PCS 361 CH 1 OUT P
B24	B_HDOUTN1_L	-	PCS 361 CH 1 OUT N	B_HDOUTN1_L	-	PCS 361 CH 1 OUT N
D24	B_VDDOB1_L	-		B_VDDOB1_L	-	
B25	B_HDOUTN0_L	-	PCS 361 CH 0 OUT N	B_HDOUTN0_L	-	PCS 361 CH 0 OUT N
D25	B_VDDOB0_L	-		B_VDDOB0_L	-	
A25	B_HDOUTP0_L	-	PCS 361 CH 0 OUT P	B_HDOUTP0_L	-	PCS 361 CH 0 OUT P
G25	B_HDINN0_L	-	PCS 361 CH 0 IN N	B_HDINN0_L	-	PCS 361 CH 0 IN N
F25	B_HDINP0_L	-	PCS 361 CH 0 IN P	B_HDINP0_L	-	PCS 361 CH 0 IN P
H25	B_VDDIB0_L	-		B_VDDIB0_L	-	
H26	A_VDDIB3_L	-		A_VDDIB3_L	-	
F26	A_HDINP3_L	-	PCS 360 CH 3 IN P	A_HDINP3_L	-	PCS 360 CH 3 IN P
G26	A_HDINN3_L	-	PCS 360 CH 3 IN N	A_HDINN3_L	-	PCS 360 CH 3 IN N
A26	A_HDOUTP3_L	-	PCS 360 CH 3 OUT P	A_HDOUTP3_L	-	PCS 360 CH 3 OUT P
B26	A_HDOUTN3_L	-	PCS 360 CH 3 OUT N	A_HDOUTN3_L	-	PCS 360 CH 3 OUT N
D26	A_VDDOB3_L	-		A_VDDOB3_L	-	
B27	A_HDOUTN2_L	-	PCS 360 CH 2 OUT N	A_HDOUTN2_L	-	PCS 360 CH 2 OUT N
D27	A_VDDOB2_L	-		A_VDDOB2_L	-	
A27	A_HDOUTP2_L	-	PCS 360 CH 2 OUT P	A_HDOUTP2_L	-	PCS 360 CH 2 OUT P
G27	A_HDINN2_L	-	PCS 360 CH 2 IN N	A_HDINN2_L	-	PCS 360 CH 2 IN N
F27	A_HDINP2_L	-	PCS 360 CH 2 IN P	A_HDINP2_L	-	PCS 360 CH 2 IN P
H27	A_VDDIB2_L	-		A_VDDIB2_L	-	
F29	A_VDDIB1_L	-		A_VDDIB1_L	-	
G28	A_HDINP1_L	-	PCS 360 CH 1 IN P	A_HDINP1_L	-	PCS 360 CH 1 IN P
H28	A_HDINN1_L	-	PCS 360 CH 1 IN N	A_HDINN1_L	-	PCS 360 CH 1 IN N
A29	A_HDOUTP1_L	-	PCS 360 CH 1 OUT P	A_HDOUTP1_L	-	PCS 360 CH 1 OUT P
B29	A_HDOUTN1_L	-	PCS 360 CH 1 OUT N	A_HDOUTN1_L	-	PCS 360 CH 1 OUT N
D29	A_VDDOB1_L	-		A_VDDOB1_L	-	

LFSC/M25, LFSC/M40 Logic Signal Connections: 1020 fcBGA^{1,2} (Cont.)

Ball Number	LFSC/M25			LFSC/M40		
	Ball Function	VCCIO Bank	Dual Function	Ball Function	VCCIO Bank	Dual Function
B30	A_HDOUTN0_L	-	PCS 360 CH 0 OUT N	A_HDOUTN0_L	-	PCS 360 CH 0 OUT N
D30	A_VDDOB0_L	-		A_VDDOB0_L	-	
A30	A_HDOUTP0_L	-	PCS 360 CH 0 OUT P	A_HDOUTP0_L	-	PCS 360 CH 0 OUT P
C31	A_HDINN0_L	-	PCS 360 CH 0 IN N	A_HDINN0_L	-	PCS 360 CH 0 IN N
C32	A_HDINP0_L	-	PCS 360 CH 0 IN P	A_HDINP0_L	-	PCS 360 CH 0 IN P
B31	A_VDDIB0_L	-		A_VDDIB0_L	-	
AL25	NC	-		PB26A	5	
AL24	NC	-		PB26B	5	
AG27	NC	-		PB26C	5	
AH27	NC	-		PB26D	5	
AM25	NC	-		PB27A	5	
AM24	NC	-		PB27B	5	
AL9	NC	-		PB62A	4	
AL8	NC	-		PB62B	4	
AK9	NC	-		PB63A	4	
AJ9	NC	-		PB63B	4	
AG10	NC	-		PB63C	4	
AG11	NC	-		PB63D	4	
J30	NC	-		PL26A	7	
H30	NC	-		PL26B	7	
M28	NC	-		PL26C	7	
N28	NC	-		PL26D	7	
J32	NC	-		PL27A	7	
J31	NC	-		PL27B	7	
N26	NC	-		PL27C	7	
N27	NC	-		PL27D	7	
K31	NC	-		PL29A	7	
K32	NC	-		PL29B	7	
P25	NC	-		PL29C	7	
P26	NC	-		PL29D	7	
L27	NC	-		PL22C	7	
L28	NC	-		PL22D	7	
M29	NC	-		PL30A	7	
L29	NC	-		PL30B	7	
M30	NC	-		PL31A	7	
L30	NC	-		PL31B	7	
L31	NC	-		PL34A	7	
M31	NC	-		PL34B	7	
AA29	NC	-		PL56A	6	
AA30	NC	-		PL56B	6	
AB31	NC	-		PL57A	6	
AA31	NC	-		PL57B	6	
AG30	NC	-		PL57C	6	
AG29	NC	-		PL57D	6	
AB29	NC	-		PL58A	6	
AB30	NC	-		PL58B	6	
Y25	NC	-		PL58C	6	
AA25	NC	-		PL58D	6	
AA8	NC	-		PR58D	3	
Y8	NC	-		PR58C	3	

LFSC/M25, LFSC/M40 Logic Signal Connections: 1020 fcBGA^{1,2} (Cont.)

Ball Number	LFSC/M25			LFSC/M40		
	Ball Function	VCCIO Bank	Dual Function	Ball Function	VCCIO Bank	Dual Function
AB3	NC	-		PR58B	3	
AB4	NC	-		PR58A	3	
AG4	NC	-		PR57D	3	
AG3	NC	-		PR57C	3	
AA2	NC	-		PR57B	3	
AB2	NC	-		PR57A	3	
AA3	NC	-		PR56B	3	
AA4	NC	-		PR56A	3	
L5	NC	-		PR22D	2	
L6	NC	-		PR22C	2	
M2	NC	-		PR34B	2	
L2	NC	-		PR34A	2	
L3	NC	-		PR31B	2	
M3	NC	-		PR31A	2	
L4	NC	-		PR30B	2	
M4	NC	-		PR30A	2	
P7	NC	-		PR29D	2	
P8	NC	-		PR29C	2	
K1	NC	-		PR29B	2	
K2	NC	-		PR29A	2	
N6	NC	-		PR27D	2	
N7	NC	-		PR27C	2	
J2	NC	-		PR27B	2	
J1	NC	-		PR27A	2	
N5	NC	-		PR26D	2	
M5	NC	-		PR26C	2	
H3	NC	-		PR26B	2	
J3	NC	-		PR26A	2	
A5	VDDAX25_R	-		VDDAX25_R	-	
A28	VDDAX25_L	-		VDDAX25_L	-	
AJ25	NC	-		PB21A	5	
AK25	NC	-		PB21B	5	
AF20	NC	-		PB27C	5	
AG6	NC	-		PB62C	4	
AM7	NC	-		PB66A	4	
AL7	NC	-		PB66B	4	
AD13	NC	-		PB66C	4	
AC13	NC	-		PB66D	4	
AC20	NC	-		PB22C	5	
AD20	NC	-		PB22D	5	
AM9	NC	-		PB61A	4	
AM8	NC	-		PB61B	4	
AF13	NC	-		PB61C	4	
AE13	NC	-		PB61D	4	
E30	VCC12	-		VCC12	-	
E29	VCC12	-		VCC12	-	
E27	VCC12	-		VCC12	-	
E26	VCC12	-		VCC12	-	
E25	VCC12	-		VCC12	-	
E24	VCC12	-		VCC12	-	

LFSC/M25, LFSC/M40 Logic Signal Connections: 1020 fcBGA^{1,2} (Cont.)

Ball Number	LFSC/M25			LFSC/M40		
	Ball Function	VCCIO Bank	Dual Function	Ball Function	VCCIO Bank	Dual Function
E22	VCC12	-		VCC12	-	
E21	VCC12	-		VCC12	-	
E3	VCC12	-		VCC12	-	
E4	VCC12	-		VCC12	-	
E6	VCC12	-		VCC12	-	
E7	VCC12	-		VCC12	-	
E8	VCC12	-		VCC12	-	
E9	VCC12	-		VCC12	-	
E11	VCC12	-		VCC12	-	
E12	VCC12	-		VCC12	-	
A23	GND	-		GND	-	
A31	GND	-		GND	-	
AA13	GND	-		GND	-	
AA15	GND	-		GND	-	
AA18	GND	-		GND	-	
AA20	GND	-		GND	-	
AA26	GND	-		GND	-	
AA6	GND	-		GND	-	
AB10	GND	-		GND	-	
AB24	GND	-		GND	-	
AC14	GND	-		GND	-	
AC22	GND	-		GND	-	
AC29	GND	-		GND	-	
AC3	GND	-		GND	-	
AD11	GND	-		GND	-	
AD19	GND	-		GND	-	
AD27	GND	-		GND	-	
AD7	GND	-		GND	-	
AF12	GND	-		GND	-	
AF18	GND	-		GND	-	
AF24	GND	-		GND	-	
AF30	GND	-		GND	-	
AF4	GND	-		GND	-	
AG15	GND	-		GND	-	
AG21	GND	-		GND	-	
AG9	GND	-		GND	-	
AJ10	GND	-		GND	-	
AJ16	GND	-		GND	-	
AJ20	GND	-		GND	-	
AJ26	GND	-		GND	-	
AJ29	GND	-		GND	-	
AJ4	GND	-		GND	-	
AK13	GND	-		GND	-	
AK17	GND	-		GND	-	
AK23	GND	-		GND	-	
AK7	GND	-		GND	-	
AL1	GND	-		GND	-	
AL32	GND	-		GND	-	
AM2	GND	-		GND	-	
AM31	GND	-		GND	-	

LFSC/M25, LFSC/M40 Logic Signal Connections: 1020 fcBGA^{1,2} (Cont.)

Ball Number	LFSC/M25			LFSC/M40		
	Ball Function	VCCIO Bank	Dual Function	Ball Function	VCCIO Bank	Dual Function
B1	GND	-		GND	-	
B32	GND	-		GND	-	
C11	GND	-		GND	-	
C12	GND	-		GND	-	
C16	GND	-		GND	-	
C21	GND	-		GND	-	
C22	GND	-		GND	-	
C24	GND	-		GND	-	
C25	GND	-		GND	-	
C26	GND	-		GND	-	
C27	GND	-		GND	-	
C29	GND	-		GND	-	
C3	GND	-		GND	-	
C30	GND	-		GND	-	
C4	GND	-		GND	-	
C6	GND	-		GND	-	
C7	GND	-		GND	-	
C8	GND	-		GND	-	
C9	GND	-		GND	-	
D17	GND	-		GND	-	
F18	GND	-		GND	-	
F3	GND	-		GND	-	
F30	GND	-		GND	-	
F9	GND	-		GND	-	
G15	GND	-		GND	-	
G24	GND	-		GND	-	
G29	GND	-		GND	-	
G3	GND	-		GND	-	
J14	GND	-		GND	-	
J22	GND	-		GND	-	
J26	GND	-		GND	-	
J6	GND	-		GND	-	
K11	GND	-		GND	-	
K19	GND	-		GND	-	
K30	GND	-		GND	-	
K4	GND	-		GND	-	
L23	GND	-		GND	-	
L9	GND	-		GND	-	
M13	GND	-		GND	-	
M15	GND	-		GND	-	
M18	GND	-		GND	-	
M20	GND	-		GND	-	
M27	GND	-		GND	-	
M7	GND	-		GND	-	
N12	GND	-		GND	-	
N14	GND	-		GND	-	
N19	GND	-		GND	-	
N21	GND	-		GND	-	
N29	GND	-		GND	-	
N3	GND	-		GND	-	

LFSC/M25, LFSC/M40 Logic Signal Connections: 1020 fcBGA^{1,2} (Cont.)

Ball Number	LFSC/M25			LFSC/M40		
	Ball Function	VCCIO Bank	Dual Function	Ball Function	VCCIO Bank	Dual Function
P10	GND	-		GND	-	
P13	GND	-		GND	-	
P15	GND	-		GND	-	
P18	GND	-		GND	-	
P20	GND	-		GND	-	
P24	GND	-		GND	-	
R12	GND	-		GND	-	
R14	GND	-		GND	-	
R16	GND	-		GND	-	
R17	GND	-		GND	-	
R19	GND	-		GND	-	
R21	GND	-		GND	-	
R26	GND	-		GND	-	
R6	GND	-		GND	-	
T15	GND	-		GND	-	
T18	GND	-		GND	-	
T30	GND	-		GND	-	
T4	GND	-		GND	-	
U15	GND	-		GND	-	
U18	GND	-		GND	-	
U29	GND	-		GND	-	
U3	GND	-		GND	-	
V12	GND	-		GND	-	
V14	GND	-		GND	-	
V16	GND	-		GND	-	
V17	GND	-		GND	-	
V19	GND	-		GND	-	
V21	GND	-		GND	-	
V27	GND	-		GND	-	
V7	GND	-		GND	-	
W13	GND	-		GND	-	
W15	GND	-		GND	-	
W18	GND	-		GND	-	
W20	GND	-		GND	-	
W23	GND	-		GND	-	
W9	GND	-		GND	-	
Y12	GND	-		GND	-	
Y14	GND	-		GND	-	
Y19	GND	-		GND	-	
Y21	GND	-		GND	-	
Y30	GND	-		GND	-	
Y4	GND	-		GND	-	
N13	VCC	-		VCC	-	
N15	VCC	-		VCC	-	
N16	VCC	-		VCC	-	
N17	VCC	-		VCC	-	
N18	VCC	-		VCC	-	
N20	VCC	-		VCC	-	
P14	VCC	-		VCC	-	
P16	VCC	-		VCC	-	

LFSC/M25, LFSC/M40 Logic Signal Connections: 1020 fcBGA^{1,2} (Cont.)

Ball Number	LFSC/M25			LFSC/M40		
	Ball Function	VCCIO Bank	Dual Function	Ball Function	VCCIO Bank	Dual Function
P17	VCC	-		VCC	-	
P19	VCC	-		VCC	-	
R13	VCC	-		VCC	-	
R15	VCC	-		VCC	-	
R18	VCC	-		VCC	-	
R20	VCC	-		VCC	-	
T13	VCC	-		VCC	-	
T14	VCC	-		VCC	-	
T16	VCC	-		VCC	-	
T17	VCC	-		VCC	-	
T19	VCC	-		VCC	-	
T20	VCC	-		VCC	-	
U13	VCC	-		VCC	-	
U14	VCC	-		VCC	-	
U16	VCC	-		VCC	-	
U17	VCC	-		VCC	-	
U19	VCC	-		VCC	-	
U20	VCC	-		VCC	-	
V13	VCC	-		VCC	-	
V15	VCC	-		VCC	-	
V18	VCC	-		VCC	-	
V20	VCC	-		VCC	-	
W14	VCC	-		VCC	-	
W16	VCC	-		VCC	-	
W17	VCC	-		VCC	-	
W19	VCC	-		VCC	-	
Y13	VCC	-		VCC	-	
Y15	VCC	-		VCC	-	
Y16	VCC	-		VCC	-	
Y17	VCC	-		VCC	-	
Y18	VCC	-		VCC	-	
Y20	VCC	-		VCC	-	
C17	VCCIO1	-		VCCIO1	-	
D16	VCCIO1	-		VCCIO1	-	
F15	VCCIO1	-		VCCIO1	-	
F24	VCCIO1	-		VCCIO1	-	
G18	VCCIO1	-		VCCIO1	-	
G9	VCCIO1	-		VCCIO1	-	
J11	VCCIO1	-		VCCIO1	-	
J19	VCCIO1	-		VCCIO1	-	
K14	VCCIO1	-		VCCIO1	-	
K22	VCCIO1	-		VCCIO1	-	
G4	VCCIO2	-		VCCIO2	-	
J7	VCCIO2	-		VCCIO2	-	
K3	VCCIO2	-		VCCIO2	-	
L10	VCCIO2	-		VCCIO2	-	
M6	VCCIO2	-		VCCIO2	-	
N4	VCCIO2	-		VCCIO2	-	
P9	VCCIO2	-		VCCIO2	-	
R7	VCCIO2	-		VCCIO2	-	

LFSC/M25, LFSC/M40 Logic Signal Connections: 1020 fcBGA^{1,2} (Cont.)

Ball Number	LFSC/M25			LFSC/M40		
	Ball Function	VCCIO Bank	Dual Function	Ball Function	VCCIO Bank	Dual Function
AA7	VCCIO3	-		VCCIO3	-	
AB9	VCCIO3	-		VCCIO3	-	
AC4	VCCIO3	-		VCCIO3	-	
AD6	VCCIO3	-		VCCIO3	-	
AF3	VCCIO3	-		VCCIO3	-	
T3	VCCIO3	-		VCCIO3	-	
U4	VCCIO3	-		VCCIO3	-	
V6	VCCIO3	-		VCCIO3	-	
W10	VCCIO3	-		VCCIO3	-	
Y3	VCCIO3	-		VCCIO3	-	
AC11	VCCIO4	-		VCCIO4	-	
AD14	VCCIO4	-		VCCIO4	-	
AF15	VCCIO4	-		VCCIO4	-	
AF9	VCCIO4	-		VCCIO4	-	
AG12	VCCIO4	-		VCCIO4	-	
AJ13	VCCIO4	-		VCCIO4	-	
AJ7	VCCIO4	-		VCCIO4	-	
AK10	VCCIO4	-		VCCIO4	-	
AK16	VCCIO4	-		VCCIO4	-	
AK4	VCCIO4	-		VCCIO4	-	
AC19	VCCIO5	-		VCCIO5	-	
AD22	VCCIO5	-		VCCIO5	-	
AF21	VCCIO5	-		VCCIO5	-	
AG18	VCCIO5	-		VCCIO5	-	
AG24	VCCIO5	-		VCCIO5	-	
AJ17	VCCIO5	-		VCCIO5	-	
AJ23	VCCIO5	-		VCCIO5	-	
AJ30	VCCIO5	-		VCCIO5	-	
AK20	VCCIO5	-		VCCIO5	-	
AK26	VCCIO5	-		VCCIO5	-	
AA27	VCCIO6	-		VCCIO6	-	
AB23	VCCIO6	-		VCCIO6	-	
AC30	VCCIO6	-		VCCIO6	-	
AD26	VCCIO6	-		VCCIO6	-	
AF29	VCCIO6	-		VCCIO6	-	
T29	VCCIO6	-		VCCIO6	-	
U30	VCCIO6	-		VCCIO6	-	
V26	VCCIO6	-		VCCIO6	-	
W24	VCCIO6	-		VCCIO6	-	
Y29	VCCIO6	-		VCCIO6	-	
G30	VCCIO7	-		VCCIO7	-	
J27	VCCIO7	-		VCCIO7	-	
K29	VCCIO7	-		VCCIO7	-	
L24	VCCIO7	-		VCCIO7	-	
M26	VCCIO7	-		VCCIO7	-	
N30	VCCIO7	-		VCCIO7	-	
P23	VCCIO7	-		VCCIO7	-	
R27	VCCIO7	-		VCCIO7	-	
AA11	VCCAUX	-		VCCAUX	-	
AA12	VCCAUX	-		VCCAUX	-	

LFSC/M25, LFSC/M40 Logic Signal Connections: 1020 fcBGA^{1,2} (Cont.)

Ball Number	LFSC/M25			LFSC/M40		
	Ball Function	VCCIO Bank	Dual Function	Ball Function	VCCIO Bank	Dual Function
AA21	VCCAUX	-		VCCAUX	-	
AA22	VCCAUX	-		VCCAUX	-	
AB11	VCCAUX	-		VCCAUX	-	
AB12	VCCAUX	-		VCCAUX	-	
AB15	VCCAUX	-		VCCAUX	-	
AB16	VCCAUX	-		VCCAUX	-	
AB17	VCCAUX	-		VCCAUX	-	
AB18	VCCAUX	-		VCCAUX	-	
AB21	VCCAUX	-		VCCAUX	-	
AB22	VCCAUX	-		VCCAUX	-	
L11	VCCAUX	-		VCCAUX	-	
L12	VCCAUX	-		VCCAUX	-	
L14	VCCAUX	-		VCCAUX	-	
L15	VCCAUX	-		VCCAUX	-	
L18	VCCAUX	-		VCCAUX	-	
L19	VCCAUX	-		VCCAUX	-	
L21	VCCAUX	-		VCCAUX	-	
L22	VCCAUX	-		VCCAUX	-	
M11	VCCAUX	-		VCCAUX	-	
M12	VCCAUX	-		VCCAUX	-	
M21	VCCAUX	-		VCCAUX	-	
M22	VCCAUX	-		VCCAUX	-	
P11	VCCAUX	-		VCCAUX	-	
P22	VCCAUX	-		VCCAUX	-	
R11	VCCAUX	-		VCCAUX	-	
R22	VCCAUX	-		VCCAUX	-	
V11	VCCAUX	-		VCCAUX	-	
V22	VCCAUX	-		VCCAUX	-	
W11	VCCAUX	-		VCCAUX	-	
W22	VCCAUX	-		VCCAUX	-	
N11	VTT_2	2		VTT_2	2	
R10	VTT_2	2		VTT_2	2	
T11	VTT_3	3		VTT_3	3	
U11	VTT_3	3		VTT_3	3	
Y11	VTT_3	3		VTT_3	3	
AB13	VTT_4	4		VTT_4	4	
AB14	VTT_4	4		VTT_4	4	
AC15	VTT_4	4		VTT_4	4	
AB19	VTT_5	5		VTT_5	5	
AB20	VTT_5	5		VTT_5	5	
AC18	VTT_5	5		VTT_5	5	
T22	VTT_6	6		VTT_6	6	
U22	VTT_6	6		VTT_6	6	
Y22	VTT_6	6		VTT_6	6	
N22	VTT_7	7		VTT_7	7	
R23	VTT_7	7		VTT_7	7	
M17	VCC12	-		VCC12	-	
M16	VCC12	-		VCC12	-	
T12	VCC12	-		VCC12	-	
T21	VCC12	-		VCC12	-	

LFSC/M25, LFSC/M40 Logic Signal Connections: 1020 fcBGA^{1,2} (Cont.)

Ball Number	LFSC/M25			LFSC/M40		
	Ball Function	VCCIO Bank	Dual Function	Ball Function	VCCIO Bank	Dual Function
U12	VCC12	-		VCC12	-	
U21	VCC12	-		VCC12	-	
AA16	VCC12	-		VCC12	-	
AA17	VCC12	-		VCC12	-	
M14	VCC12	-		VCC12	-	
P12	VCC12	-		VCC12	-	
W12	VCC12	-		VCC12	-	
AA14	VCC12	-		VCC12	-	
AA19	VCC12	-		VCC12	-	
W21	VCC12	-		VCC12	-	
P21	VCC12	-		VCC12	-	
M19	VCC12	-		VCC12	-	
A2	GND	-		GND	-	
A10	GND	-		GND	-	
E28	NC	-		NC	-	
E5	NC	-		NC	-	
F10	NC	-		NC	-	
E10	NC	-		NC	-	
E23	NC	-		NC	-	
F23	NC	-		NC	-	

1. Differential pair grouping within a PIC is A (True) and B (Complement) and C (True) and D (Complement).
2. The LatticeSC/M25 and LatticeSC/M40 in a 1020-pin package support a 16-bit MPI interface.

LFSC/M40, LFSC/M80 Logic Signal Connections: 1152 fcBGA^{1,2}

Ball Number	LFSC/M40			LFSC/M80		
	Ball Function	VCCIO Bank	Dual Function	Ball Function	VCCIO Bank	Dual Function
G27	A_REFCLKP_L	-		A_REFCLKP_L	-	
H27	A_REFCLKN_L	-		A_REFCLKN_L	-	
H25	VCC12	-		VCC12	-	
H26	RESP_ULC	-		RESP_ULC	-	
B33	RESETN	1		RESETN	1	
C34	TSALLN	1		TSALLN	1	
D34	DONE	1		DONE	1	
C33	INITN	1		INITN	1	
J27	M0	1		M0	1	
K27	M1	1		M1	1	
M26	M2	1		M2	1	
L26	M3	1		M3	1	
F30	PL16A	7	ULC_PLLT_IN_A/ULC_PLLT_FB_B	PL16A	7	ULC_PLLT_IN_A/ULC_PLLT_FB_B
G30	PL16B	7	ULC_PLLC_IN_A/ULC_PLLC_FB_B	PL16B	7	ULC_PLLC_IN_A/ULC_PLLC_FB_B
H28	PL16C	7		PL16C	7	
J28	PL16D	7		PL16D	7	
F31	PL17A	7	ULC_DLLT_IN_C/ULC_DLLT_FB_D	PL17A	7	ULC_DLLT_IN_C/ULC_DLLT_FB_D
G31	PL17B	7	ULC_DLLC_IN_C/ULC_DLLC_FB_D	PL17B	7	ULC_DLLC_IN_C/ULC_DLLC_FB_D
N25	PL17C	7	ULC_PLLT_IN_B/ULC_PLLT_FB_A	PL17C	7	ULC_PLLT_IN_B/ULC_PLLT_FB_A
P25	PL17D	7	ULC_PLLC_IN_B/ULC_PLLC_FB_A	PL17D	7	ULC_PLLC_IN_B/ULC_PLLC_FB_A
D33	PL18A	7	ULC_DLLT_IN_D/ULC_DLLT_FB_C	PL18A	7	ULC_DLLT_IN_D/ULC_DLLT_FB_C
E33	PL18B	7	ULC_DLLC_IN_D/ULC_DLLC_FB_C	PL18B	7	ULC_DLLC_IN_D/ULC_DLLC_FB_C
H29	PL18C	7		PL18C	7	
J29	PL18D	7	VREF2_7	PL18D	7	VREF2_7
F32	PL21A	7		PL20A	7	
G32	PL21B	7		PL20B	7	
P26	PL21C	7		PL20C	7	
N26	PL21D	7		PL20D	7	
H30	PL22A	7		PL21A	7	
J30	PL22B	7		PL21B	7	
L28	PL22C	7		PL21C	7	
M28	PL22D	7		PL21D	7	
J31	PL23A	7		PL29A	7	
K31	PL23B	7		PL29B	7	
L27	PL23C	7	VREF1_7	PL29C	7	VREF1_7
M27	PL23D	7	DIFFR_7	PL29D	7	DIFFR_7
J32	PL25A	7		PL31A	7	
K32	PL25B	7		PL31B	7	
L29	PL25C	7		PL31C	7	
M29	PL25D	7		PL31D	7	
H33	PL26A	7		PL33A	7	
J33	PL26B	7		PL33B	7	
N27	PL26C	7		PL33C	7	
P27	PL26D	7		PL33D	7	
K33	PL27A	7		PL35A	7	

LFSC/M40, LFSC/M80 Logic Signal Connections: 1152 fcBGA^{1,2} (Cont.)

Ball Number	LFSC/M40			LFSC/M80		
	Ball Function	VCCIO Bank	Dual Function	Ball Function	VCCIO Bank	Dual Function
L33	PL27B	7		PL35B	7	
M30	PL27C	7		PL35C	7	
N30	PL27D	7		PL35D	7	
M31	PL29A	7		PL37A	7	
N31	PL29B	7		PL37B	7	
P24	PL29C	7		PL37C	7	
R24	PL29D	7		PL37D	7	
M33	PL30A	7		PL42A	7	
N33	PL30B	7		PL42B	7	
U25	PL30C	7		PL42C	7	
T25	PL30D	7		PL42D	7	
L34	PL31A	7		PL43A	7	
M34	PL31B	7		PL43B	7	
P29	PL31C	7		PL43C	7	
R29	PL31D	7		PL43D	7	
N34	PL34A	7		PL46A	7	
P34	PL34B	7		PL46B	7	
R27	PL34C	7		PL46C	7	
T27	PL34D	7		PL46D	7	
R32	PL35A	7	PCLKT7_1	PL47A	7	PCLKT7_1
R31	PL35B	7	PCLKC7_1	PL47B	7	PCLKC7_1
U24	PL35C	7	PCLKT7_3	PL47C	7	PCLKT7_3
T24	PL35D	7	PCLKC7_3	PL47D	7	PCLKC7_3
P33	PL36A	7	PCLKT7_0	PL48A	7	PCLKT7_0
R33	PL36B	7	PCLKC7_0	PL48B	7	PCLKC7_0
T26	PL36C	7	PCLKT7_2	PL48C	7	PCLKT7_2
U26	PL36D	7	PCLKC7_2	PL48D	7	PCLKC7_2
T32	PL38A	6	PCLKT6_0	PL50A	6	PCLKT6_0
T31	PL38B	6	PCLKC6_0	PL50B	6	PCLKC6_0
U29	PL38C	6	PCLKT6_1	PL50C	6	PCLKT6_1
V29	PL38D	6	PCLKC6_1	PL50D	6	PCLKC6_1
T30	PL39A	6		PL51A	6	
U30	PL39B	6		PL51B	6	
U27	PL39C	6	PCLKT6_3	PL51C	6	PCLKT6_3
V27	PL39D	6	PCLKC6_3	PL51D	6	PCLKC6_3
R34	PL40A	6		PL52A	6	
T34	PL40B	6		PL52B	6	
U28	PL40C	6	PCLKT6_2	PL52C	6	PCLKT6_2
V28	PL40D	6	PCLKC6_2	PL52D	6	PCLKC6_2
V30	PL43A	6		PL55A	6	
W30	PL43B	6		PL55B	6	
W27	PL43C	6	VREF1_6	PL55C	6	VREF1_6
Y27	PL43D	6		PL55D	6	
T33	PL44A	6		PL56A	6	
U33	PL44B	6		PL56B	6	

LFSC/M40, LFSC/M80 Logic Signal Connections: 1152 fcBGA^{1,2} (Cont.)

Ball Number	LFSC/M40			LFSC/M80		
	Ball Function	VCCIO Bank	Dual Function	Ball Function	VCCIO Bank	Dual Function
V25	PL44C	6		PL56C	6	
W25	PL44D	6		PL56D	6	
U34	PL45A	6		PL57A	6	
V34	PL45B	6		PL57B	6	
V26	PL45C	6		PL57C	6	
W26	PL45D	6		PL57D	6	
V33	PL47A	6		PL60A	6	
W33	PL47B	6		PL60B	6	
V24	PL47C	6		PL60C	6	
W24	PL47D	6		PL60D	6	
W31	PL48A	6		PL63A	6	
Y31	PL48B	6		PL63B	6	
Y29	PL48C	6		PL63C	6	
AA29	PL48D	6		PL63D	6	
Y33	PL49A	6		PL65A	6	
AA33	PL49B	6		PL65B	6	
Y28	PL49C	6		PL65C	6	
AA28	PL49D	6		PL65D	6	
AB32	PL51A	6		PL76A	6	
AC32	PL51B	6		PL76B	6	
AA26	PL51C	6		PL76C	6	
AA27	PL51D	6	DIFFR_6	PL76D	6	DIFFR_6
AB31	PL52A	6		PL77A	6	
AC31	PL52B	6		PL77B	6	
Y24	PL52C	6		PL77C	6	
AA24	PL52D	6		PL77D	6	
AE34	PL53A	6		PL78A	6	
AF34	PL53B	6		PL78B	6	
AB30	PL53C	6		PL78C	6	
AC30	PL53D	6		PL78D	6	
AD33	PL56A	6		PL80A	6	
AE33	PL56B	6		PL80B	6	
AD30	PL56C	6		PL80C	6	
AE30	PL56D	6		PL80D	6	
AE32	PL57A	6		PL81A	6	
AF32	PL57B	6		PL81B	6	
AA25	PL57C	6		PL81C	6	
AB25	PL57D	6		PL81D	6	
AJ34	PL58A	6		PL82A	6	
AK34	PL58B	6		PL82B	6	
AB27	PL58C	6		PL82C	6	
AC27	PL58D	6		PL82D	6	
AF33	PL60A	6		PL84A	6	
AG33	PL60B	6		PL84B	6	
AC29	PL60C	6		PL84C	6	

LFSC/M40, LFSC/M80 Logic Signal Connections: 1152 fcBGA^{1,2} (Cont.)

Ball Number	LFSC/M40			LFSC/M80		
	Ball Function	VCCIO Bank	Dual Function	Ball Function	VCCIO Bank	Dual Function
AD29	PL60D	6		PL84D	6	
AE31	PL61A	6		PL85A	6	
AF31	PL61B	6		PL85B	6	
AF30	PL61C	6		PL85C	6	
AF29	PL61D	6		PL85D	6	
AH33	PL62A	6		PL86A	6	
AJ33	PL62B	6		PL86B	6	
AC28	PL62C	6		PL86C	6	
AD28	PL62D	6		PL86D	6	
AH32	PL65A	6		PL89A	6	
AJ32	PL65B	6		PL89B	6	
AD27	PL65C	6		PL89C	6	
AE27	PL65D	6	VREF2_6	PL89D	6	VREF2_6
AG34	PL66A	6		PL90A	6	
AH34	PL66B	6		PL90B	6	
AC26	PL66C	6		PL90C	6	
AB26	PL66D	6		PL90D	6	
AK33	PL67A	6		PL91A	6	
AL33	PL67B	6		PL91B	6	
AG30	PL67C	6		PL91C	6	
AH30	PL67D	6		PL91D	6	
AL34	PL69A	6		PL93A	6	
AM34	PL69B	6		PL93B	6	
AJ30	PL69C	6	LLC_DLLT_IN_E/LLC_DLLT_FB_F	PL93C	6	LLC_DLLT_IN_E/LLC_DLLT_FB_F
AK30	PL69D	6	LLC_DLLC_IN_E/LLC_DLLC_FB_F	PL93D	6	LLC_DLLC_IN_E/LLC_DLLC_FB_F
AJ31	PL70A	6		PL94A	6	
AH31	PL70B	6		PL94B	6	
AD26	PL70C	6		PL94C	6	
AD25	PL70D	6		PL94D	6	
AL32	PL71A	6	LLC_DLLT_IN_F/LLC_DLLT_FB_E	PL95A	6	LLC_DLLT_IN_F/LLC_DLLT_FB_E
AL31	PL71B	6	LLC_DLLC_IN_F/LLC_DLLC_FB_E	PL95B	6	LLC_DLLC_IN_F/LLC_DLLC_FB_E
AG29	PL71C	6	LLC_PLLT_IN_B/LLC_PLLT_FB_A	PL95C	6	LLC_PLLT_IN_B/LLC_PLLT_FB_A
AG28	PL71D	6	LLC_PLLC_IN_B/LLC_PLLC_FB_A	PL95D	6	LLC_PLLC_IN_B/LLC_PLLC_FB_A
AF28	XRES	-		XRES	-	
AF27	TEMP	6		TEMP	6	
AM33	PB3A	5	LLC_PLLT_IN_A/LLC_PLLT_FB_B	PB3A	5	LLC_PLLT_IN_A/LLC_PLLT_FB_B
AN33	PB3B	5	LLC_PLLC_IN_A/LLC_PLLC_FB_B	PB3B	5	LLC_PLLC_IN_A/LLC_PLLC_FB_B
AH29	PB3C	5	LLC_DLLT_IN_C/LLC_DLLT_FB_D	PB3C	5	LLC_DLLT_IN_C/LLC_DLLT_FB_D
AJ29	PB3D	5	LLC_DLLC_IN_C/LLC_DLLC_FB_D	PB3D	5	LLC_DLLC_IN_C/LLC_DLLC_FB_D
AM32	PB4A	5	LLC_DLLT_IN_D/LLC_DLLT_FB_C	PB4A	5	LLC_DLLT_IN_D/LLC_DLLT_FB_C
AM31	PB4B	5	LLC_DLLC_IN_D/LLC_DLLC_FB_C	PB4B	5	LLC_DLLC_IN_D/LLC_DLLC_FB_C
AG27	PB4C	5		PB4C	5	
AG26	PB4D	5		PB4D	5	
AL29	PB5A	5		PB5A	5	
AL28	PB5B	5		PB5B	5	

LFSC/M40, LFSC/M80 Logic Signal Connections: 1152 fcBGA^{1,2} (Cont.)

Ball Number	LFSC/M40			LFSC/M80		
	Ball Function	VCCIO Bank	Dual Function	Ball Function	VCCIO Bank	Dual Function
AH27	PB5C	5		PB5C	5	
AH26	PB5D	5	VREF1_5	PB5D	5	VREF1_5
AN32	PB7A	5		PB7A	5	
AP32	PB7B	5		PB7B	5	
AF25	PB7C	5		PB7C	5	
AE25	PB7D	5		PB7D	5	
AN31	PB8A	5		PB9A	5	
AN30	PB8B	5		PB9B	5	
AK29	PB8C	5		PB9C	5	
AK28	PB8D	5		PB9D	5	
AP31	PB9A	5		PB11A	5	
AP30	PB9B	5		PB11B	5	
AD24	PB9C	5		PB11C	5	
AE24	PB9D	5		PB11D	5	
AM29	PB11A	5		PB13A	5	
AM28	PB11B	5		PB13B	5	
AJ27	PB11C	5		PB13C	5	
AJ26	PB11D	5		PB13D	5	
AP29	PB13A	5		PB15A	5	
AP28	PB13B	5		PB15B	5	
AK27	PB13C	5		PB15C	5	
AK26	PB13D	5		PB15D	5	
AN29	PB15A	5		PB17A	5	
AN28	PB15B	5		PB17B	5	
AG25	PB15C	5		PB17C	5	
AG24	PB15D	5		PB17D	5	
AL26	PB17A	5		PB19A	5	
AL25	PB17B	5		PB19B	5	
AG23	PB17C	5		PB19C	5	
AG22	PB17D	5		PB19D	5	
AN27	PB19A	5		PB21A	5	
AN26	PB19B	5		PB21B	5	
AF24	PB19C	5		PB21C	5	
AF23	PB19D	5		PB21D	5	
AP27	PB22A	5		PB24A	5	
AP26	PB22B	5		PB24B	5	
AK25	PB22C	5		PB24C	5	
AK24	PB22D	5		PB24D	5	
AN25	PB25A	5		PB27A	5	
AN24	PB25B	5		PB27B	5	
AE22	PB25C	5		PB27C	5	
AE21	PB25D	5		PB27D	5	
AM26	PB26A	5		PB29A	5	
AM25	PB26B	5		PB29B	5	
AF22	PB26C	5		PB29C	5	

LFSC/M40, LFSC/M80 Logic Signal Connections: 1152 fcBGA^{1,2} (Cont.)

Ball Number	LFSC/M40			LFSC/M80		
	Ball Function	VCCIO Bank	Dual Function	Ball Function	VCCIO Bank	Dual Function
AF21	PB26D	5		PB29D	5	
AN23	PB27A	5		PB45A	5	
AN22	PB27B	5		PB45B	5	
AP23	PB29A	5		PB55A	5	
AP22	PB29B	5		PB55B	5	
AG21	PB29C	5		PB55C	5	
AG20	PB29D	5		PB55D	5	
AP25	PB30A	5	PCLKT5_3	PB48A	5	PCLKT5_3
AP24	PB30B	5	PCLKC5_3	PB48B	5	PCLKC5_3
AD21	PB30C	5	PCLKT5_4	PB48C	5	PCLKT5_4
AD20	PB30D	5	PCLKC5_4	PB48D	5	PCLKC5_4
AL23	PB31A	5	PCLKT5_5	PB49A	5	PCLKT5_5
AL22	PB31B	5	PCLKC5_5	PB49B	5	PCLKC5_5
AH24	PB31C	5		PB49C	5	
AH23	PB31D	5		PB49D	5	
AM23	PB33A	5	PCLKT5_0	PB51A	5	PCLKT5_0
AM22	PB33B	5	PCLKC5_0	PB51B	5	PCLKC5_0
AJ24	PB33C	5		PB51C	5	
AJ23	PB33D	5	VREF2_5	PB51D	5	VREF2_5
AN21	PB34A	5	PCLKT5_1	PB52A	5	PCLKT5_1
AN20	PB34B	5	PCLKC5_1	PB52B	5	PCLKC5_1
AE19	PB34C	5	PCLKT5_6	PB52C	5	PCLKT5_6
AD19	PB34D	5	PCLKC5_6	PB52D	5	PCLKC5_6
AK21	PB35A	5	PCLKT5_2	PB53A	5	PCLKT5_2
AK20	PB35B	5	PCLKC5_2	PB53B	5	PCLKC5_2
AK23	PB35C	5	PCLKT5_7	PB53C	5	PCLKT5_7
AK22	PB35D	5	PCLKC5_7	PB53D	5	PCLKC5_7
AL20	PB37A	5		PB56A	5	
AL19	PB37B	5		PB56B	5	
AG19	PB37C	5		PB56C	5	
AF19	PB37D	5		PB56D	5	
AP21	PB38A	5		PB57A	5	
AP20	PB38B	5		PB57B	5	
AH21	PB38C	5		PB57C	5	
AH20	PB38D	5		PB57D	5	
AM20	PB39A	5		PB59A	5	
AM19	PB39B	5		PB59B	5	
AJ21	PB39C	5		PB59C	5	
AJ20	PB39D	5		PB59D	5	
AK19	PB41A	5		PB60A	5	
AK18	PB41B	5		PB60B	5	
AE18	PB41C	5		PB60C	5	
AD18	PB41D	5		PB60D	5	
AN19	PB42A	5		PB61A	5	
AN18	PB42B	5		PB61B	5	

LFSC/M40, LFSC/M80 Logic Signal Connections: 1152 fcBGA^{1,2} (Cont.)

Ball Number	LFSC/M40			LFSC/M80		
	Ball Function	VCCIO Bank	Dual Function	Ball Function	VCCIO Bank	Dual Function
AG18	PB42C	5		PB61C	5	
AF18	PB42D	5		PB61D	5	
AP19	PB43A	5		PB63A	5	
AP18	PB43B	5		PB63B	5	
AJ18	PB43C	5		PB63C	5	
AH18	PB43D	5		PB63D	5	
AP17	PB45A	4		PB65A	4	
AP16	PB45B	4		PB65B	4	
AJ17	PB45C	4		PB65C	4	
AH17	PB45D	4		PB65D	4	
AN17	PB46A	4		PB66A	4	
AN16	PB46B	4		PB66B	4	
AE17	PB46C	4		PB66C	4	
AD17	PB46D	4		PB66D	4	
AK17	PB47A	4		PB67A	4	
AK16	PB47B	4		PB67B	4	
AG17	PB47C	4		PB67C	4	
AF17	PB47D	4		PB67D	4	
AM16	PB49A	4		PB69A	4	
AM15	PB49B	4		PB69B	4	
AJ15	PB49C	4		PB69C	4	
AJ14	PB49D	4		PB69D	4	
AL16	PB50A	4		PB70A	4	
AL15	PB50B	4		PB70B	4	
AG16	PB50C	4		PB70C	4	
AF16	PB50D	4		PB70D	4	
AP15	PB51A	4		PB71A	4	
AP14	PB51B	4		PB71B	4	
AH15	PB51C	4		PB71C	4	
AH14	PB51D	4		PB71D	4	
AN15	PB53A	4	PCLKT4_2	PB74A	4	PCLKT4_2
AN14	PB53B	4	PCLKC4_2	PB74B	4	PCLKC4_2
AE16	PB53C	4	PCLKT4_7	PB74C	4	PCLKT4_7
AD16	PB53D	4	PCLKC4_7	PB74D	4	PCLKC4_7
AK15	PB54A	4	PCLKT4_1	PB75A	4	PCLKT4_1
AK14	PB54B	4	PCLKC4_1	PB75B	4	PCLKC4_1
AG15	PB54C	4	PCLKT4_6	PB75C	4	PCLKT4_6
AG14	PB54D	4	PCLKC4_6	PB75D	4	PCLKC4_6
AM13	PB55A	4	PCLKT4_0	PB77A	4	PCLKT4_0
AM12	PB55B	4	PCLKC4_0	PB77B	4	PCLKC4_0
AJ12	PB55C	4	VREF2_4	PB77C	4	VREF2_4
AJ11	PB55D	4		PB77D	4	
AL13	PB57A	4	PCLKT4_5	PB79A	4	PCLKT4_5
AL12	PB57B	4	PCLKC4_5	PB79B	4	PCLKC4_5
AH12	PB57C	4		PB79C	4	

LFSC/M40, LFSC/M80 Logic Signal Connections: 1152 fcBGA^{1,2} (Cont.)

Ball Number	LFSC/M40			LFSC/M80		
	Ball Function	VCCIO Bank	Dual Function	Ball Function	VCCIO Bank	Dual Function
AH11	PB57D	4		PB79D	4	
AN13	PB58A	4	PCLKT4_3	PB80A	4	PCLKT4_3
AN12	PB58B	4	PCLKC4_3	PB80B	4	PCLKC4_3
AD14	PB58C	4	PCLKT4_4	PB80C	4	PCLKT4_4
AD15	PB58D	4	PCLKC4_4	PB80D	4	PCLKC4_4
AP13	PB61A	4		PB73A	4	
AP12	PB61B	4		PB73B	4	
AK13	PB61C	4		PB73C	4	
AK12	PB61D	4		PB73D	4	
AP11	PB62A	4		PB83A	4	
AP10	PB62B	4		PB83B	4	
AN11	PB63A	4		PB99A	4	
AN10	PB63B	4		PB99B	4	
AF14	PB63C	4		PB99C	4	
AF13	PB63D	4		PB99D	4	
AM10	PB67A	4		PB101A	4	
AM9	PB67B	4		PB101B	4	
AE14	PB67C	4		PB101C	4	
AE13	PB67D	4		PB101D	4	
AP9	PB69A	4		PB104A	4	
AP8	PB69B	4		PB104B	4	
AK11	PB69C	4		PB104C	4	
AK10	PB69D	4		PB104D	4	
AL10	PB70A	4		PB107A	4	
AL9	PB70B	4		PB107B	4	
AF12	PB70C	4		PB107C	4	
AF11	PB70D	4		PB107D	4	
AN9	PB73A	4		PB109A	4	
AN8	PB73B	4		PB109B	4	
AG11	PB73C	4		PB109C	4	
AG10	PB73D	4		PB109D	4	
AP7	PB74A	4		PB111A	4	
AP6	PB74B	4		PB111B	4	
AG13	PB74C	4		PB111C	4	
AG12	PB74D	4		PB111D	4	
AN7	PB75A	4		PB113A	4	
AN6	PB75B	4		PB113B	4	
AK9	PB75C	4		PB113C	4	
AK8	PB75D	4		PB113D	4	
AP5	PB77A	4		PB115A	4	
AP4	PB77B	4		PB115B	4	
AD11	PB77C	4		PB115C	4	
AE11	PB77D	4		PB115D	4	
AM7	PB78A	4		PB117A	4	
AM6	PB78B	4		PB117B	4	

LFSC/M40, LFSC/M80 Logic Signal Connections: 1152 fcBGA^{1,2} (Cont.)

Ball Number	LFSC/M40			LFSC/M80		
	Ball Function	VCCIO Bank	Dual Function	Ball Function	VCCIO Bank	Dual Function
AJ9	PB78C	4		PB117C	4	
AJ8	PB78D	4		PB117D	4	
AP3	PB79A	4		PB119A	4	
AN3	PB79B	4		PB119B	4	
AF10	PB79C	4		PB119C	4	
AE10	PB79D	4		PB119D	4	
AL7	PB81A	4		PB121A	4	
AL6	PB81B	4		PB121B	4	
AK7	PB81C	4		PB121C	4	
AK6	PB81D	4		PB121D	4	
AN5	PB82A	4		PB123A	4	
AN4	PB82B	4		PB123B	4	
AH9	PB82C	4	VREF1_4	PB123C	4	VREF1_4
AH8	PB82D	4		PB123D	4	
AM3	PB83A	4	LRC_DLLT_IN_C/LRC_DLLT_FB_D	PB124A	4	LRC_DLLT_IN_C/LRC_DLLT_FB_D
AM4	PB83B	4	LRC_DLLC_IN_C/LRC_DLLC_FB_D	PB124B	4	LRC_DLLC_IN_C/LRC_DLLC_FB_D
AG9	PB83C	4		PB124C	4	
AG8	PB83D	4		PB124D	4	
AN2	PB85A	4	LRC_PLLT_IN_A/LRC_PLLT_FB_B	PB125A	4	LRC_PLLT_IN_A/LRC_PLLT_FB_B
AM2	PB85B	4	LRC_PLLC_IN_A/LRC_PLLC_FB_B	PB125B	4	LRC_PLLC_IN_A/LRC_PLLC_FB_B
AJ6	PB85C	4	LRC_DLLT_IN_D/LRC_DLLT_FB_C	PB125C	4	LRC_DLLT_IN_D/LRC_DLLT_FB_C
AH6	PB85D	4	LRC_DLLC_IN_D/LRC_DLLC_FB_C	PB125D	4	LRC_DLLC_IN_D/LRC_DLLC_FB_C
AF7	PROBE_VCC	-		PROBE_VCC	-	
AF8	PROBE_GND	-		PROBE_GND	-	
AG7	PR71D	3	LRC_PLLC_IN_B/LRC_PLLC_FB_A	PR95D	3	LRC_PLLC_IN_B/LRC_PLLC_FB_A
AG6	PR71C	3	LRC_PLLT_IN_B/LRC_PLLT_FB_A	PR95C	3	LRC_PLLT_IN_B/LRC_PLLT_FB_A
AL4	PR71B	3	LRC_DLLC_IN_F/LRC_DLLC_FB_E	PR95B	3	LRC_DLLC_IN_F/LRC_DLLC_FB_E
AL3	PR71A	3	LRC_DLLT_IN_F/LRC_DLLT_FB_E	PR95A	3	LRC_DLLT_IN_F/LRC_DLLT_FB_E
AD10	PR70D	3		PR94D	3	
AD9	PR70C	3		PR94C	3	
AH4	PR70B	3		PR94B	3	
AJ4	PR70A	3		PR94A	3	
AK5	PR69D	3	LRC_DLLC_IN_E/LRC_DLLC_FB_F	PR93D	3	LRC_DLLC_IN_E/LRC_DLLC_FB_F
AJ5	PR69C	3	LRC_DLLT_IN_E/LRC_DLLT_FB_F	PR93C	3	LRC_DLLT_IN_E/LRC_DLLT_FB_F
AM1	PR69B	3		PR93B	3	
AL1	PR69A	3		PR93A	3	
AH5	PR67D	3		PR91D	3	
AG5	PR67C	3		PR91C	3	
AL2	PR67B	3		PR91B	3	
AK2	PR67A	3		PR91A	3	
AB9	PR66D	3		PR90D	3	
AC9	PR66C	3		PR90C	3	
AH1	PR66B	3		PR90B	3	
AG1	PR66A	3		PR90A	3	
AE8	PR65D	3	VREF2_3	PR89D	3	VREF2_3

LFSC/M40, LFSC/M80 Logic Signal Connections: 1152 fcBGA^{1,2} (Cont.)

Ball Number	LFSC/M40			LFSC/M80		
	Ball Function	VCCIO Bank	Dual Function	Ball Function	VCCIO Bank	Dual Function
AD8	PR65C	3		PR89C	3	
AJ3	PR65B	3		PR89B	3	
AH3	PR65A	3		PR89A	3	
AD7	PR62D	3		PR86D	3	
AC7	PR62C	3		PR86C	3	
AJ2	PR62B	3		PR86B	3	
AH2	PR62A	3		PR86A	3	
AF6	PR61D	3		PR85D	3	
AF5	PR61C	3		PR85C	3	
AF4	PR61B	3		PR85B	3	
AE4	PR61A	3		PR85A	3	
AD6	PR60D	3		PR84D	3	
AC6	PR60C	3		PR84C	3	
AG2	PR60B	3		PR84B	3	
AF2	PR60A	3		PR84A	3	
AC8	PR58D	3		PR82D	3	
AB8	PR58C	3		PR82C	3	
AK1	PR58B	3		PR82B	3	
AJ1	PR58A	3		PR82A	3	
AB10	PR57D	3		PR81D	3	
AA10	PR57C	3		PR81C	3	
AF3	PR57B	3		PR81B	3	
AE3	PR57A	3		PR81A	3	
AE5	PR56D	3		PR80D	3	
AD5	PR56C	3		PR80C	3	
AE2	PR56B	3		PR80B	3	
AD2	PR56A	3		PR80A	3	
AC5	PR53D	3		PR78D	3	
AB5	PR53C	3		PR78C	3	
AF1	PR53B	3		PR78B	3	
AE1	PR53A	3		PR78A	3	
AA11	PR52D	3		PR77D	3	
Y11	PR52C	3		PR77C	3	
AC4	PR52B	3		PR77B	3	
AB4	PR52A	3		PR77A	3	
AA8	PR51D	3	DIFFR_3	PR76D	3	DIFFR_3
AA9	PR51C	3		PR76C	3	
AC3	PR51B	3		PR76B	3	
AB3	PR51A	3		PR76A	3	
AA7	PR49D	3		PR65D	3	
Y7	PR49C	3		PR65C	3	
AA2	PR49B	3		PR65B	3	
Y2	PR49A	3		PR65A	3	
AA6	PR48D	3		PR63D	3	
Y6	PR48C	3		PR63C	3	

LFSC/M40, LFSC/M80 Logic Signal Connections: 1152 fcBGA^{1,2} (Cont.)

Ball Number	LFSC/M40			LFSC/M80		
	Ball Function	VCCIO Bank	Dual Function	Ball Function	VCCIO Bank	Dual Function
Y4	PR48B	3		PR63B	3	
W4	PR48A	3		PR63A	3	
W11	PR47D	3		PR60D	3	
V11	PR47C	3		PR60C	3	
W2	PR47B	3		PR60B	3	
V2	PR47A	3		PR60A	3	
W9	PR45D	3		PR57D	3	
V9	PR45C	3		PR57C	3	
V1	PR45B	3		PR57B	3	
U1	PR45A	3		PR57A	3	
W10	PR44D	3		PR56D	3	
V10	PR44C	3		PR56C	3	
U2	PR44B	3		PR56B	3	
T2	PR44A	3		PR56A	3	
Y8	PR43D	3		PR55D	3	
W8	PR43C	3	VREF1_3	PR55C	3	VREF1_3
W5	PR43B	3		PR55B	3	
V5	PR43A	3		PR55A	3	
V7	PR40D	3	PCLKC3_2	PR52D	3	PCLKC3_2
U7	PR40C	3	PCLKT3_2	PR52C	3	PCLKT3_2
T1	PR40B	3		PR52B	3	
R1	PR40A	3		PR52A	3	
V8	PR39D	3	PCLKC3_3	PR51D	3	PCLKC3_3
U8	PR39C	3	PCLKT3_3	PR51C	3	PCLKT3_3
U5	PR39B	3		PR51B	3	
T5	PR39A	3		PR51A	3	
V6	PR38D	3	PCLKC3_1	PR50D	3	PCLKC3_1
U6	PR38C	3	PCLKT3_1	PR50C	3	PCLKT3_1
T4	PR38B	3	PCLKC3_0	PR50B	3	PCLKC3_0
T3	PR38A	3	PCLKT3_0	PR50A	3	PCLKT3_0
U9	PR36D	2	PCLKC2_2	PR48D	2	PCLKC2_2
T9	PR36C	2	PCLKT2_2	PR48C	2	PCLKT2_2
R2	PR36B	2	PCLKC2_0	PR48B	2	PCLKC2_0
P2	PR36A	2	PCLKT2_0	PR48A	2	PCLKT2_0
T11	PR35D	2	PCLKC2_3	PR47D	2	PCLKC2_3
U11	PR35C	2	PCLKT2_3	PR47C	2	PCLKT2_3
R4	PR35B	2	PCLKC2_1	PR47B	2	PCLKC2_1
R3	PR35A	2	PCLKT2_1	PR47A	2	PCLKT2_1
T8	PR34D	2		PR46D	2	
R8	PR34C	2		PR46C	2	
P1	PR34B	2		PR46B	2	
N1	PR34A	2		PR46A	2	
R6	PR31D	2		PR43D	2	
P6	PR31C	2		PR43C	2	
M1	PR31B	2		PR43B	2	

LFSC/M40, LFSC/M80 Logic Signal Connections: 1152 fcBGA^{1,2} (Cont.)

Ball Number	LFSC/M40			LFSC/M80		
	Ball Function	VCCIO Bank	Dual Function	Ball Function	VCCIO Bank	Dual Function
L1	PR31A	2		PR43A	2	
T10	PR30D	2		PR42D	2	
U10	PR30C	2		PR42C	2	
N2	PR30B	2		PR42B	2	
M2	PR30A	2		PR42A	2	
R11	PR29D	2		PR37D	2	
P11	PR29C	2		PR37C	2	
N4	PR29B	2		PR37B	2	
M4	PR29A	2		PR37A	2	
N5	PR27D	2		PR35D	2	
M5	PR27C	2		PR35C	2	
L2	PR27B	2		PR35B	2	
K2	PR27A	2		PR35A	2	
P8	PR26D	2		PR33D	2	
N8	PR26C	2		PR33C	2	
J2	PR26B	2		PR33B	2	
H2	PR26A	2		PR33A	2	
M6	PR25D	2		PR31D	2	
L6	PR25C	2		PR31C	2	
K3	PR25B	2		PR31B	2	
J3	PR25A	2		PR31A	2	
M8	PR23D	2	DIFFR_2	PR29D	2	DIFFR_2
L8	PR23C	2	VREF1_2	PR29C	2	VREF1_2
K4	PR23B	2		PR29B	2	
J4	PR23A	2		PR29A	2	
M7	PR22D	2		PR21D	2	
L7	PR22C	2		PR21C	2	
J5	PR22B	2		PR21B	2	
H5	PR22A	2		PR21A	2	
N9	PR21D	2		PR20D	2	
P9	PR21C	2		PR20C	2	
G3	PR21B	2		PR20B	2	
F3	PR21A	2		PR20A	2	
J6	PR18D	2	VREF2_2	PR18D	2	VREF2_2
H6	PR18C	2		PR18C	2	
E2	PR18B	2	URC_DLLC_IN_D/URC_DLLC_FB_C	PR18B	2	URC_DLLC_IN_D/URC_DLLC_FB_C
D2	PR18A	2	URC_DLLT_IN_D/URC_DLLT_FB_C	PR18A	2	URC_DLLT_IN_D/URC_DLLT_FB_C
P10	PR17D	2	URC_PLLC_IN_B/URC_PLLC_FB_A	PR17D	2	URC_PLLC_IN_B/URC_PLLC_FB_A
N10	PR17C	2	URC_PLLT_IN_B/URC_PLLT_FB_A	PR17C	2	URC_PLLT_IN_B/URC_PLLT_FB_A
G4	PR17B	2	URC_DLLC_IN_C/URC_DLLC_FB_D	PR17B	2	URC_DLLC_IN_C/URC_DLLC_FB_D
F4	PR17A	2	URC_DLLT_IN_C/URC_DLLT_FB_D	PR17A	2	URC_DLLT_IN_C/URC_DLLT_FB_D
J7	PR16D	2		PR16D	2	
H7	PR16C	2		PR16C	2	
G5	PR16B	2	URC_PLLC_IN_A/URC_PLLC_FB_B	PR16B	2	URC_PLLC_IN_A/URC_PLLC_FB_B
F5	PR16A	2	URC_PLLT_IN_A/URC_PLLT_FB_B	PR16A	2	URC_PLLT_IN_A/URC_PLLT_FB_B

LFSC/M40, LFSC/M80 Logic Signal Connections: 1152 fcBGA^{1,2} (Cont.)

Ball Number	LFSC/M40			LFSC/M80		
	Ball Function	VCCIO Bank	Dual Function	Ball Function	VCCIO Bank	Dual Function
C2	VCCJ	-		VCCJ	-	
M9	TDO	-	TDO	TDO	-	TDO
L9	TMS	-		TMS	-	
D1	TCK	-		TCK	-	
C1	TDI	-		TDI	-	
J8	PROGRAMN	1		PROGRAMN	1	
K8	MPIIRQN	1	CFGIRQN/MPI_IRQ_N	MPIIRQN	1	CFGIRQN/MPI_IRQ_N
B2	CCLK	1		CCLK	1	
H9	RESP_URC	-		RESP_URC	-	
H10	VCC12	-		VCC12	-	
H8	A_REFCLKN_R	-		A_REFCLKN_R	-	
G8	A_REFCLKP_R	-		A_REFCLKP_R	-	
C3	VCC12	-		VCC12	-	
D3	A_VDDIB0_R	-		A_VDDIB0_R	-	
A3	A_HDINP0_R	-	PCS 3E0 CH 0 IN P	A_HDINP0_R	-	PCS 3E0 CH 0 IN P
B3	A_HDINN0_R	-	PCS 3E0 CH 0 IN N	A_HDINN0_R	-	PCS 3E0 CH 0 IN N
E5	VCC12	-		VCC12	-	
A4	A_HDOUTP0_R	-	PCS 3E0 CH 0 OUT P	A_HDOUTP0_R	-	PCS 3E0 CH 0 OUT P
F6	A_VDDOB0_R	-		A_VDDOB0_R	-	
B4	A_HDOUTN0_R	-	PCS 3E0 CH 0 OUT N	A_HDOUTN0_R	-	PCS 3E0 CH 0 OUT N
F7	A_VDDOB1_R	-		A_VDDOB1_R	-	
B5	A_HDOUTN1_R	-	PCS 3E0 CH 1 OUT N	A_HDOUTN1_R	-	PCS 3E0 CH 1 OUT N
E6	VCC12	-		VCC12	-	
A5	A_HDOUTP1_R	-	PCS 3E0 CH 1 OUT P	A_HDOUTP1_R	-	PCS 3E0 CH 1 OUT P
B6	A_HDINN1_R	-	PCS 3E0 CH 1 IN N	A_HDINN1_R	-	PCS 3E0 CH 1 IN N
A6	A_HDINP1_R	-	PCS 3E0 CH 1 IN P	A_HDINP1_R	-	PCS 3E0 CH 1 IN P
C6	VCC12	-		VCC12	-	
D4	A_VDDIB1_R	-		A_VDDIB1_R	-	
C7	VCC12	-		VCC12	-	
D5	A_VDDIB2_R	-		A_VDDIB2_R	-	
A7	A_HDINP2_R	-	PCS 3E0 CH 2 IN P	A_HDINP2_R	-	PCS 3E0 CH 2 IN P
B7	A_HDINN2_R	-	PCS 3E0 CH 2 IN N	A_HDINN2_R	-	PCS 3E0 CH 2 IN N
E7	VCC12	-		VCC12	-	
A8	A_HDOUTP2_R	-	PCS 3E0 CH 2 OUT P	A_HDOUTP2_R	-	PCS 3E0 CH 2 OUT P
F8	A_VDDOB2_R	-		A_VDDOB2_R	-	
B8	A_HDOUTN2_R	-	PCS 3E0 CH 2 OUT N	A_HDOUTN2_R	-	PCS 3E0 CH 2 OUT N
F9	A_VDDOB3_R	-		A_VDDOB3_R	-	
B9	A_HDOUTN3_R	-	PCS 3E0 CH 3 OUT N	A_HDOUTN3_R	-	PCS 3E0 CH 3 OUT N
E8	VCC12	-		VCC12	-	
A9	A_HDOUTP3_R	-	PCS 3E0 CH 3 OUT P	A_HDOUTP3_R	-	PCS 3E0 CH 3 OUT P
B10	A_HDINN3_R	-	PCS 3E0 CH 3 IN N	A_HDINN3_R	-	PCS 3E0 CH 3 IN N
A10	A_HDINP3_R	-	PCS 3E0 CH 3 IN P	A_HDINP3_R	-	PCS 3E0 CH 3 IN P
C10	VCC12	-		VCC12	-	
D6	A_VDDIB3_R	-		A_VDDIB3_R	-	
G10	VCC12	-		VCC12	-	

LFSC/M40, LFSC/M80 Logic Signal Connections: 1152 fcBGA^{1,2} (Cont.)

Ball Number	LFSC/M40			LFSC/M80		
	Ball Function	VCCIO Bank	Dual Function	Ball Function	VCCIO Bank	Dual Function
D7	B_VDDIB0_R	-		B_VDDIB0_R	-	
E10	B_HDINP0_R	-	PCS 3E1 CH 0 IN P	B_HDINP0_R	-	PCS 3E1 CH 0 IN P
F10	B_HDINN0_R	-	PCS 3E1 CH 0 IN N	B_HDINN0_R	-	PCS 3E1 CH 0 IN N
K10	VCC12	-		VCC12	-	
A11	B_HDOUTP0_R	-	PCS 3E1 CH 0 OUT P	B_HDOUTP0_R	-	PCS 3E1 CH 0 OUT P
D10	B_VDDOB0_R	-		B_VDDOB0_R	-	
B11	B_HDOUTN0_R	-	PCS 3E1 CH 0 OUT N	B_HDOUTN0_R	-	PCS 3E1 CH 0 OUT N
D11	B_VDDOB1_R	-		B_VDDOB1_R	-	
B12	B_HDOUTN1_R	-	PCS 3E1 CH 1 OUT N	B_HDOUTN1_R	-	PCS 3E1 CH 1 OUT N
L10	VCC12	-		VCC12	-	
A12	B_HDOUTP1_R	-	PCS 3E1 CH 1 OUT P	B_HDOUTP1_R	-	PCS 3E1 CH 1 OUT P
F11	B_HDINN1_R	-	PCS 3E1 CH 1 IN N	B_HDINN1_R	-	PCS 3E1 CH 1 IN N
E11	B_HDINP1_R	-	PCS 3E1 CH 1 IN P	B_HDINP1_R	-	PCS 3E1 CH 1 IN P
G11	VCC12	-		VCC12	-	
D8	B_VDDIB1_R	-		B_VDDIB1_R	-	
G12	VCC12	-		VCC12	-	
D9	B_VDDIB2_R	-		B_VDDIB2_R	-	
E12	B_HDINP2_R	-	PCS 3E1 CH 2 IN P	B_HDINP2_R	-	PCS 3E1 CH 2 IN P
F12	B_HDINN2_R	-	PCS 3E1 CH 2 IN N	B_HDINN2_R	-	PCS 3E1 CH 2 IN N
K11	VCC12	-		VCC12	-	
A13	B_HDOUTP2_R	-	PCS 3E1 CH 2 OUT P	B_HDOUTP2_R	-	PCS 3E1 CH 2 OUT P
D12	B_VDDOB2_R	-		B_VDDOB2_R	-	
B13	B_HDOUTN2_R	-	PCS 3E1 CH 2 OUT N	B_HDOUTN2_R	-	PCS 3E1 CH 2 OUT N
D13	B_VDDOB3_R	-		B_VDDOB3_R	-	
B14	B_HDOUTN3_R	-	PCS 3E1 CH 3 OUT N	B_HDOUTN3_R	-	PCS 3E1 CH 3 OUT N
L11	VCC12	-		VCC12	-	
A14	B_HDOUTP3_R	-	PCS 3E1 CH 3 OUT P	B_HDOUTP3_R	-	PCS 3E1 CH 3 OUT P
F13	B_HDINN3_R	-	PCS 3E1 CH 3 IN N	B_HDINN3_R	-	PCS 3E1 CH 3 IN N
E13	B_HDINP3_R	-	PCS 3E1 CH 3 IN P	B_HDINP3_R	-	PCS 3E1 CH 3 IN P
G13	VCC12	-		VCC12	-	
E9	B_VDDIB3_R	-		B_VDDIB3_R	-	
L13	VCC12	-		VCC12	-	
J11	B_REFCLKN_R	-		B_REFCLKN_R	-	
H11	B_REFCLKP_R	-		B_REFCLKP_R	-	
M15	PT61D	1	HDC/SI	PT77D	1	HDC/SI
M16	PT61C	1	LDCN/SCS	PT77C	1	LDCN/SCS
F14	PT59B	1	D8/MPI_DATA8	PT77B	1	D8/MPI_DATA8
G14	PT59A	1	CS1/MPI_CS1	PT77A	1	CS1/MPI_CS1
L15	PT58D	1	D9/MPI_DATA9	PT75D	1	D9/MPI_DATA9
L14	PT58C	1	D10/MPI_DATA10	PT75C	1	D10/MPI_DATA10
D14	PT57B	1	CS0N/MPI_CS0N	PT75B	1	CS0N/MPI_CS0N
E14	PT57A	1	RDN/MPI_STRB_N	PT75A	1	RDN/MPI_STRB_N
L16	PT55D	1	WRN/MPI_WR_N	PT74D	1	WRN/MPI_WR_N
K16	PT55C	1	D7/MPI_DATA7	PT74C	1	D7/MPI_DATA7
G15	PT55B	1	D6/MPI_DATA6	PT74B	1	D6/MPI_DATA6

LFSC/M40, LFSC/M80 Logic Signal Connections: 1152 fcBGA^{1,2} (Cont.)

Ball Number	LFSC/M40			LFSC/M80		
	Ball Function	VCCIO Bank	Dual Function	Ball Function	VCCIO Bank	Dual Function
F15	PT55A	1	D5/MPI_DATA5	PT74A	1	D5/MPI_DATA5
K14	PT54D	1	D4/MPI_DATA4	PT73D	1	D4/MPI_DATA4
K13	PT54C	1	D3/MPI_DATA3	PT73C	1	D3/MPI_DATA3
B15	PT53B	1	D2/MPI_DATA2	PT73B	1	D2/MPI_DATA2
A15	PT53A	1	D1/MPI_DATA1	PT73A	1	D1/MPI_DATA1
J14	PT51D	1	D16/PCLKC1_3/MPI_DATA16	PT71D	1	D16/PCLKC1_3/MPI_DATA16
H14	PT51C	1	D17/PCLKT1_3/MPI_DATA17	PT71C	1	D17/PCLKT1_3/MPI_DATA17
A16	PT51B	1	D0/MPI_DATA0	PT71B	1	D0/MPI_DATA0
B16	PT51A	1	QOUT/CEON	PT71A	1	QOUT/CEON
J13	PT50D	1	VREF2_1	PT70D	1	VREF2_1
H13	PT50C	1	D18/MPI_DATA18	PT70C	1	D18/MPI_DATA18
D15	PT50B	1	DOUT	PT70B	1	DOUT
E15	PT50A	1	MCA_DONE_IN	PT70A	1	MCA_DONE_IN
J16	PT49D	1	D19/PCLKC1_2/MPI_DATA19	PT69D	1	D19/PCLKC1_2/MPI_DATA19
J17	PT49C	1	D20/PCLKT1_2/MPI_DATA20	PT69C	1	D20/PCLKT1_2/MPI_DATA20
D16	PT49B	1	MCA_CLK_P1_OUT	PT69B	1	MCA_CLK_P1_OUT
E16	PT49A	1	MCA_CLK_P1_IN	PT69A	1	MCA_CLK_P1_IN
H15	PT47D	1	D21/PCLKC1_1/MPI_DATA21	PT67D	1	D21/PCLKC1_1/MPI_DATA21
H16	PT47C	1	D22/PCLKT1_1/MPI_DATA22	PT67C	1	D22/PCLKT1_1/MPI_DATA22
C15	PT47B	1	MCA_CLK_P2_OUT	PT67B	1	MCA_CLK_P2_OUT
C16	PT47A	1	MCA_CLK_P2_IN	PT67A	1	MCA_CLK_P2_IN
L17	PT46D	1	MCA_DONE_OUT	PT66D	1	MCA_DONE_OUT
K17	PT46C	1	BUSYN/RCLK/SCK	PT66C	1	BUSYN/RCLK/SCK
E17	PT46B	1	DP0/MPI_PAR0	PT66B	1	DP0/MPI_PAR0
F17	PT46A	1	MPI_TA	PT66A	1	MPI_TA
G17	PT45D	1	D23/MPI_DATA23	PT65D	1	D23/MPI_DATA23
H17	PT45C	1	DP2/MPI_PAR2	PT65C	1	DP2/MPI_PAR2
A17	PT45B	1	PCLKC1_0	PT65B	1	PCLKC1_0
B17	PT45A	1	PCLKT1_0/MPI_CLK	PT65A	1	PCLKT1_0/MPI_CLK
G18	PT43D	1	DP3/PCLKC1_4/MPI_PAR3	PT63D	1	DP3/PCLKC1_4/MPI_PAR3
H18	PT43C	1	D24/PCLKT1_4/MPI_DATA24	PT63C	1	D24/PCLKT1_4/MPI_DATA24
E18	PT43B	1	MPI_RETRY	PT63B	1	MPI_RETRY
F18	PT43A	1	A0/MPI_ADDR14	PT63A	1	A0/MPI_ADDR14
J18	PT42D	1	A1/MPI_ADDR15	PT61D	1	A1/MPI_ADDR15
J19	PT42C	1	A2/MPI_ADDR16	PT61C	1	A2/MPI_ADDR16
C20	PT42B	1	A3/MPI_ADDR17	PT61B	1	A3/MPI_ADDR17
C19	PT42A	1	A4/MPI_ADDR18	PT61A	1	A4/MPI_ADDR18
K18	PT41D	1	D25/PCLKC1_5/MPI_DATA25	PT60D	1	D25/PCLKC1_5/MPI_DATA25
L18	PT41C	1	D26/PCLKT1_5/MPI_DATA26	PT60C	1	D26/PCLKT1_5/MPI_DATA26
D19	PT41B	1	A5/MPI_ADDR19	PT60B	1	A5/MPI_ADDR19
E19	PT41A	1	A6/MPI_ADDR20	PT60A	1	A6/MPI_ADDR20
H19	PT39D	1	D27/MPI_DATA27	PT59D	1	D27/MPI_DATA27
H20	PT39C	1	VREF1_1	PT59C	1	VREF1_1
A18	PT39B	1	A7/MPI_ADDR21	PT59B	1	A7/MPI_ADDR21
B18	PT39A	1	A8/MPI_ADDR22	PT59A	1	A8/MPI_ADDR22

LFSC/M40, LFSC/M80 Logic Signal Connections: 1152 fcBGA^{1,2} (Cont.)

Ball Number	LFSC/M40			LFSC/M80		
	Ball Function	VCCIO Bank	Dual Function	Ball Function	VCCIO Bank	Dual Function
H21	PT38D	1	D28/PCLKC1_6/MPI_DATA28	PT57D	1	D28/PCLKC1_6/MPI_DATA28
J21	PT38C	1	D29/PCLKT1_6/MPI_DATA29	PT57C	1	D29/PCLKT1_6/MPI_DATA29
A19	PT38B	1	A9/MPI_ADDR23	PT57B	1	A9/MPI_ADDR23
B19	PT38A	1	A10/MPI_ADDR24	PT57A	1	A10/MPI_ADDR24
H22	PT37D	1	D30/PCLKC1_7/MPI_DATA30	PT56D	1	D30/PCLKC1_7/MPI_DATA30
J22	PT37C	1	D31/PCLKT1_7/MPI_DATA31	PT56C	1	D31/PCLKT1_7/MPI_DATA31
F20	PT37B	1	A11/MPI_ADDR25	PT56B	1	A11/MPI_ADDR25
G20	PT37A	1	A12/MPI_ADDR26	PT56A	1	A12/MPI_ADDR26
K21	PT35D	1	D11/MPI_DATA11	PT55D	1	D11/MPI_DATA11
K22	PT35C	1	D12/MPI_DATA12	PT55C	1	D12/MPI_DATA12
A20	PT35B	1	A13/MPI_ADDR27	PT55B	1	A13/MPI_ADDR27
B20	PT35A	1	A14/MPI_ADDR28	PT55A	1	A14/MPI_ADDR28
L21	PT33D	1	A16/MPI_ADDR30	PT53D	1	A16/MPI_ADDR30
L20	PT33C	1	D13/MPI_DATA13	PT53C	1	D13/MPI_DATA13
D20	PT33B	1	A15/MPI_ADDR29	PT53B	1	A15/MPI_ADDR29
E20	PT33A	1	A17/MPI_ADDR31	PT53A	1	A17/MPI_ADDR31
L19	PT30D	1	A19/MPI_TSIZ1	PT52D	1	A19/MPI_TSIZ1
K19	PT30C	1	A20/MPI_BDIP	PT52C	1	A20/MPI_BDIP
D21	PT30B	1	A18/MPI_TSIZ0	PT52B	1	A18/MPI_TSIZ0
E21	PT30A	1	MPI_TEA	PT52A	1	MPI_TEA
M20	PT28D	1	D14/MPI_DATA14	PT51D	1	D14/MPI_DATA14
M19	PT28C	1	DP1/MPI_PAR1	PT51C	1	DP1/MPI_PAR1
F21	PT27B	1	A21/MPI_BURST	PT51B	1	A21/MPI_BURST
G21	PT27A	1	D15/MPI_DATA15	PT51A	1	D15/MPI_DATA15
H24	B_REFCLKP_L	-		B_REFCLKP_L	-	
J24	B_REFCLKN_L	-		B_REFCLKN_L	-	
L22	VCC12	-		VCC12	-	
E26	B_VDDIB3_L	-		B_VDDIB3_L	-	
G22	VCC12	-		VCC12	-	
E22	B_HDINP3_L	-	PCS 361 CH 3 IN P	B_HDINP3_L	-	PCS 361 CH 3 IN P
F22	B_HDINN3_L	-	PCS 361 CH 3 IN N	B_HDINN3_L	-	PCS 361 CH 3 IN N
A21	B_HDOUTP3_L	-	PCS 361 CH 3 OUT P	B_HDOUTP3_L	-	PCS 361 CH 3 OUT P
L24	VCC12	-		VCC12	-	
B21	B_HDOUTN3_L	-	PCS 361 CH 3 OUT N	B_HDOUTN3_L	-	PCS 361 CH 3 OUT N
D22	B_VDDOB3_L	-		B_VDDOB3_L	-	
B22	B_HDOUTN2_L	-	PCS 361 CH 2 OUT N	B_HDOUTN2_L	-	PCS 361 CH 2 OUT N
D23	B_VDDOB2_L	-		B_VDDOB2_L	-	
A22	B_HDOUTP2_L	-	PCS 361 CH 2 OUT P	B_HDOUTP2_L	-	PCS 361 CH 2 OUT P
K24	VCC12	-		VCC12	-	
F23	B_HDINN2_L	-	PCS 361 CH 2 IN N	B_HDINN2_L	-	PCS 361 CH 2 IN N
E23	B_HDINP2_L	-	PCS 361 CH 2 IN P	B_HDINP2_L	-	PCS 361 CH 2 IN P
D26	B_VDDIB2_L	-		B_VDDIB2_L	-	
G23	VCC12	-		VCC12	-	
D27	B_VDDIB1_L	-		B_VDDIB1_L	-	
G24	VCC12	-		VCC12	-	

LFSC/M40, LFSC/M80 Logic Signal Connections: 1152 fcBGA^{1,2} (Cont.)

Ball Number	LFSC/M40			LFSC/M80		
	Ball Function	VCCIO Bank	Dual Function	Ball Function	VCCIO Bank	Dual Function
E24	B_HDINP1_L	-	PCS 361 CH 1 IN P	B_HDINP1_L	-	PCS 361 CH 1 IN P
F24	B_HDINN1_L	-	PCS 361 CH 1 IN N	B_HDINN1_L	-	PCS 361 CH 1 IN N
A23	B_HDOUTP1_L	-	PCS 361 CH 1 OUT P	B_HDOUTP1_L	-	PCS 361 CH 1 OUT P
L25	VCC12	-		VCC12	-	
B23	B_HDOUTN1_L	-	PCS 361 CH 1 OUT N	B_HDOUTN1_L	-	PCS 361 CH 1 OUT N
D24	B_VDDOB1_L	-		B_VDDOB1_L	-	
B24	B_HDOUTN0_L	-	PCS 361 CH 0 OUT N	B_HDOUTN0_L	-	PCS 361 CH 0 OUT N
D25	B_VDDOB0_L	-		B_VDDOB0_L	-	
A24	B_HDOUTP0_L	-	PCS 361 CH 0 OUT P	B_HDOUTP0_L	-	PCS 361 CH 0 OUT P
K25	VCC12	-		VCC12	-	
F25	B_HDINN0_L	-	PCS 361 CH 0 IN N	B_HDINN0_L	-	PCS 361 CH 0 IN N
E25	B_HDINP0_L	-	PCS 361 CH 0 IN P	B_HDINP0_L	-	PCS 361 CH 0 IN P
D28	B_VDDIB0_L	-		B_VDDIB0_L	-	
G25	VCC12	-		VCC12	-	
D29	A_VDDIB3_L	-		A_VDDIB3_L	-	
C25	VCC12	-		VCC12	-	
A25	A_HDINP3_L	-	PCS 360 CH 3 IN P	A_HDINP3_L	-	PCS 360 CH 3 IN P
B25	A_HDINN3_L	-	PCS 360 CH 3 IN N	A_HDINN3_L	-	PCS 360 CH 3 IN N
A26	A_HDOUTP3_L	-	PCS 360 CH 3 OUT P	A_HDOUTP3_L	-	PCS 360 CH 3 OUT P
E27	VCC12	-		VCC12	-	
B26	A_HDOUTN3_L	-	PCS 360 CH 3 OUT N	A_HDOUTN3_L	-	PCS 360 CH 3 OUT N
F26	A_VDDOB3_L	-		A_VDDOB3_L	-	
B27	A_HDOUTN2_L	-	PCS 360 CH 2 OUT N	A_HDOUTN2_L	-	PCS 360 CH 2 OUT N
F27	A_VDDOB2_L	-		A_VDDOB2_L	-	
A27	A_HDOUTP2_L	-	PCS 360 CH 2 OUT P	A_HDOUTP2_L	-	PCS 360 CH 2 OUT P
E28	VCC12	-		VCC12	-	
B28	A_HDINN2_L	-	PCS 360 CH 2 IN N	A_HDINN2_L	-	PCS 360 CH 2 IN N
A28	A_HDINP2_L	-	PCS 360 CH 2 IN P	A_HDINP2_L	-	PCS 360 CH 2 IN P
D30	A_VDDIB2_L	-		A_VDDIB2_L	-	
C28	VCC12	-		VCC12	-	
D31	A_VDDIB1_L	-		A_VDDIB1_L	-	
C29	VCC12	-		VCC12	-	
A29	A_HDINP1_L	-	PCS 360 CH 1 IN P	A_HDINP1_L	-	PCS 360 CH 1 IN P
B29	A_HDINN1_L	-	PCS 360 CH 1 IN N	A_HDINN1_L	-	PCS 360 CH 1 IN N
A30	A_HDOUTP1_L	-	PCS 360 CH 1 OUT P	A_HDOUTP1_L	-	PCS 360 CH 1 OUT P
E29	VCC12	-		VCC12	-	
B30	A_HDOUTN1_L	-	PCS 360 CH 1 OUT N	A_HDOUTN1_L	-	PCS 360 CH 1 OUT N
F28	A_VDDOB1_L	-		A_VDDOB1_L	-	
B31	A_HDOUTN0_L	-	PCS 360 CH 0 OUT N	A_HDOUTN0_L	-	PCS 360 CH 0 OUT N
F29	A_VDDOB0_L	-		A_VDDOB0_L	-	
A31	A_HDOUTP0_L	-	PCS 360 CH 0 OUT P	A_HDOUTP0_L	-	PCS 360 CH 0 OUT P
E30	VCC12	-		VCC12	-	
B32	A_HDINN0_L	-	PCS 360 CH 0 IN N	A_HDINN0_L	-	PCS 360 CH 0 IN N
A32	A_HDINP0_L	-	PCS 360 CH 0 IN P	A_HDINP0_L	-	PCS 360 CH 0 IN P
D32	A_VDDIB0_L	-		A_VDDIB0_L	-	

LFSC/M40, LFSC/M80 Logic Signal Connections: 1152 fcBGA^{1,2} (Cont.)

Ball Number	LFSC/M40			LFSC/M80		
	Ball Function	VCCIO Bank	Dual Function	Ball Function	VCCIO Bank	Dual Function
C32	VCC12	-		VCC12	-	
E34	NC	-		PL22A	7	
F34	NC	-		PL22B	7	
F33	NC	-		PL24A	7	
G33	NC	-		PL24B	7	
K30	NC	-		PL25A	7	
L30	NC	-		PL25B	7	
G34	NC	-		PL26A	7	
H34	NC	-		PL26B	7	
M32	NC	-		PL39A	7	
N32	NC	-		PL39B	7	
P28	NC	-		PL39C	7	
R28	NC	-		PL39D	7	
J34	NC	-		PL41A	7	
K34	NC	-		PL41B	7	
P30	NC	-		PL41C	7	
R30	NC	-		PL41D	7	
W34	NC	-		PL59A	6	
Y34	NC	-		PL59B	6	
W32	NC	-		PL61A	6	
Y32	NC	-		PL61B	6	
AA34	NC	-		PL64A	6	
AB34	NC	-		PL64B	6	
AC34	NC	-		PL67A	6	
AD34	NC	-		PL67B	6	
Y30	NC	-		PL68A	6	
AA30	NC	-		PL68B	6	
AB33	NC	-		PL69A	6	
AC33	NC	-		PL69B	6	
AC2	NC	-		PR69B	3	
AB2	NC	-		PR69A	3	
AA5	NC	-		PR68B	3	
Y5	NC	-		PR68A	3	
AD1	NC	-		PR67B	3	
AC1	NC	-		PR67A	3	
AB1	NC	-		PR64B	3	
AA1	NC	-		PR64A	3	
Y3	NC	-		PR61B	3	
W3	NC	-		PR61A	3	
Y1	NC	-		PR59B	3	
W1	NC	-		PR59A	3	
R5	NC	-		PR41D	2	
P5	NC	-		PR41C	2	
K1	NC	-		PR41B	2	
J1	NC	-		PR41A	2	

LFSC/M40, LFSC/M80 Logic Signal Connections: 1152 fcBGA^{1,2} (Cont.)

Ball Number	LFSC/M40			LFSC/M80		
	Ball Function	VCCIO Bank	Dual Function	Ball Function	VCCIO Bank	Dual Function
R7	NC	-		PR39D	2	
P7	NC	-		PR39C	2	
N3	NC	-		PR39B	2	
M3	NC	-		PR39A	2	
H1	NC	-		PR26B	2	
G1	NC	-		PR26A	2	
L5	NC	-		PR25B	2	
K5	NC	-		PR25A	2	
G2	NC	-		PR24B	2	
F2	NC	-		PR24A	2	
F1	NC	-		PR22B	2	
E1	NC	-		PR22A	2	
A2	GND	-		GND	-	
A33	GND	-		GND	-	
AA15	GND	-		GND	-	
AA20	GND	-		GND	-	
AA32	GND	-		GND	-	
AA4	GND	-		GND	-	
AB28	GND	-		GND	-	
AB6	GND	-		GND	-	
AC11	GND	-		GND	-	
AC18	GND	-		GND	-	
AC25	GND	-		GND	-	
AD23	GND	-		GND	-	
AD3	GND	-		GND	-	
AD31	GND	-		GND	-	
AE12	GND	-		GND	-	
AE15	GND	-		GND	-	
AE29	GND	-		GND	-	
AE7	GND	-		GND	-	
AE9	GND	-		GND	-	
AF20	GND	-		GND	-	
AF26	GND	-		GND	-	
AG32	GND	-		GND	-	
AG4	GND	-		GND	-	
AH13	GND	-		GND	-	
AH19	GND	-		GND	-	
AH25	GND	-		GND	-	
AH7	GND	-		GND	-	
AJ10	GND	-		GND	-	
AJ16	GND	-		GND	-	
AJ22	GND	-		GND	-	
AJ28	GND	-		GND	-	
AK3	GND	-		GND	-	
AK31	GND	-		GND	-	

LFSC/M40, LFSC/M80 Logic Signal Connections: 1152 fcBGA^{1,2} (Cont.)

Ball Number	LFSC/M40			LFSC/M80		
	Ball Function	VCCIO Bank	Dual Function	Ball Function	VCCIO Bank	Dual Function
AL11	GND	-		GND	-	
AL17	GND	-		GND	-	
AL21	GND	-		GND	-	
AL27	GND	-		GND	-	
AL5	GND	-		GND	-	
AM14	GND	-		GND	-	
AM18	GND	-		GND	-	
AM24	GND	-		GND	-	
AM30	GND	-		GND	-	
AM8	GND	-		GND	-	
AN1	GND	-		GND	-	
AN34	GND	-		GND	-	
AP2	GND	-		GND	-	
AP33	GND	-		GND	-	
B1	GND	-		GND	-	
B34	GND	-		GND	-	
C11	GND	-		GND	-	
C12	GND	-		GND	-	
C13	GND	-		GND	-	
C14	GND	-		GND	-	
C17	GND	-		GND	-	
C21	GND	-		GND	-	
C22	GND	-		GND	-	
C23	GND	-		GND	-	
C24	GND	-		GND	-	
C26	GND	-		GND	-	
C27	GND	-		GND	-	
C30	GND	-		GND	-	
C31	GND	-		GND	-	
C4	GND	-		GND	-	
C5	GND	-		GND	-	
C8	GND	-		GND	-	
C9	GND	-		GND	-	
D18	GND	-		GND	-	
E32	GND	-		GND	-	
E4	GND	-		GND	-	
F19	GND	-		GND	-	
G16	GND	-		GND	-	
G29	GND	-		GND	-	
G7	GND	-		GND	-	
H3	GND	-		GND	-	
H31	GND	-		GND	-	
J10	GND	-		GND	-	
J15	GND	-		GND	-	
J26	GND	-		GND	-	

LFSC/M40, LFSC/M80 Logic Signal Connections: 1152 fcBGA^{1,2} (Cont.)

Ball Number	LFSC/M40			LFSC/M80		
	Ball Function	VCCIO Bank	Dual Function	Ball Function	VCCIO Bank	Dual Function
K20	GND	-		GND	-	
K23	GND	-		GND	-	
K26	GND	-		GND	-	
K28	GND	-		GND	-	
K6	GND	-		GND	-	
K9	GND	-		GND	-	
L12	GND	-		GND	-	
L32	GND	-		GND	-	
L4	GND	-		GND	-	
M10	GND	-		GND	-	
M17	GND	-		GND	-	
M24	GND	-		GND	-	
N29	GND	-		GND	-	
N7	GND	-		GND	-	
P15	GND	-		GND	-	
P20	GND	-		GND	-	
P3	GND	-		GND	-	
P31	GND	-		GND	-	
R10	GND	-		GND	-	
R14	GND	-		GND	-	
R16	GND	-		GND	-	
R19	GND	-		GND	-	
R21	GND	-		GND	-	
R26	GND	-		GND	-	
T15	GND	-		GND	-	
T17	GND	-		GND	-	
T18	GND	-		GND	-	
T20	GND	-		GND	-	
T28	GND	-		GND	-	
T6	GND	-		GND	-	
U16	GND	-		GND	-	
U19	GND	-		GND	-	
U23	GND	-		GND	-	
U32	GND	-		GND	-	
U4	GND	-		GND	-	
V12	GND	-		GND	-	
V16	GND	-		GND	-	
V19	GND	-		GND	-	
V3	GND	-		GND	-	
V31	GND	-		GND	-	
W15	GND	-		GND	-	
W17	GND	-		GND	-	
W18	GND	-		GND	-	
W20	GND	-		GND	-	
W29	GND	-		GND	-	

LFSC/M40, LFSC/M80 Logic Signal Connections: 1152 fcBGA^{1,2} (Cont.)

Ball Number	LFSC/M40			LFSC/M80		
	Ball Function	VCCIO Bank	Dual Function	Ball Function	VCCIO Bank	Dual Function
W7	GND	-		GND	-	
AA14	VCC	-		VCC	-	
AA16	VCC	-		VCC	-	
AA17	VCC	-		VCC	-	
AA18	VCC	-		VCC	-	
AA19	VCC	-		VCC	-	
AA21	VCC	-		VCC	-	
AB13	VCC	-		VCC	-	
AB22	VCC	-		VCC	-	
N13	VCC	-		VCC	-	
N22	VCC	-		VCC	-	
P14	VCC	-		VCC	-	
P16	VCC	-		VCC	-	
P17	VCC	-		VCC	-	
P18	VCC	-		VCC	-	
P19	VCC	-		VCC	-	
P21	VCC	-		VCC	-	
R15	VCC	-		VCC	-	
R17	VCC	-		VCC	-	
R18	VCC	-		VCC	-	
R20	VCC	-		VCC	-	
T14	VCC	-		VCC	-	
T16	VCC	-		VCC	-	
T19	VCC	-		VCC	-	
T21	VCC	-		VCC	-	
U14	VCC	-		VCC	-	
U15	VCC	-		VCC	-	
U17	VCC	-		VCC	-	
U18	VCC	-		VCC	-	
U20	VCC	-		VCC	-	
U21	VCC	-		VCC	-	
V14	VCC	-		VCC	-	
V15	VCC	-		VCC	-	
V17	VCC	-		VCC	-	
V18	VCC	-		VCC	-	
V20	VCC	-		VCC	-	
V21	VCC	-		VCC	-	
W14	VCC	-		VCC	-	
W16	VCC	-		VCC	-	
W19	VCC	-		VCC	-	
W21	VCC	-		VCC	-	
Y15	VCC	-		VCC	-	
Y17	VCC	-		VCC	-	
Y18	VCC	-		VCC	-	
Y20	VCC	-		VCC	-	

LFSC/M40, LFSC/M80 Logic Signal Connections: 1152 fcBGA^{1,2} (Cont.)

Ball Number	LFSC/M40			LFSC/M80		
	Ball Function	VCCIO Bank	Dual Function	Ball Function	VCCIO Bank	Dual Function
AB15	VCC12	-		VCC12	-	
AB20	VCC12	-		VCC12	-	
N15	VCC12	-		VCC12	-	
N20	VCC12	-		VCC12	-	
R13	VCC12	-		VCC12	-	
R22	VCC12	-		VCC12	-	
Y13	VCC12	-		VCC12	-	
Y22	VCC12	-		VCC12	-	
AA12	VCCAUX	-		VCCAUX	-	
AA23	VCCAUX	-		VCCAUX	-	
AB12	VCCAUX	-		VCCAUX	-	
AB16	VCCAUX	-		VCCAUX	-	
AB17	VCCAUX	-		VCCAUX	-	
AB18	VCCAUX	-		VCCAUX	-	
AB19	VCCAUX	-		VCCAUX	-	
AB23	VCCAUX	-		VCCAUX	-	
AC12	VCCAUX	-		VCCAUX	-	
AC13	VCCAUX	-		VCCAUX	-	
Y19	GND	-		GND	-	
AC14	VCCAUX	-		VCCAUX	-	
AC17	VCCAUX	-		VCCAUX	-	
AC21	VCCAUX	-		VCCAUX	-	
AC22	VCCAUX	-		VCCAUX	-	
AC23	VCCAUX	-		VCCAUX	-	
M13	VCCAUX	-		VCCAUX	-	
M14	VCCAUX	-		VCCAUX	-	
M18	VCCAUX	-		VCCAUX	-	
M21	VCCAUX	-		VCCAUX	-	
M22	VCCAUX	-		VCCAUX	-	
N12	VCCAUX	-		VCCAUX	-	
N16	VCCAUX	-		VCCAUX	-	
N17	VCCAUX	-		VCCAUX	-	
N18	VCCAUX	-		VCCAUX	-	
N19	VCCAUX	-		VCCAUX	-	
N23	VCCAUX	-		VCCAUX	-	
P12	VCCAUX	-		VCCAUX	-	
P23	VCCAUX	-		VCCAUX	-	
T13	VCCAUX	-		VCCAUX	-	
T22	VCCAUX	-		VCCAUX	-	
U12	VCCAUX	-		VCCAUX	-	
U13	VCCAUX	-		VCCAUX	-	
U22	VCCAUX	-		VCCAUX	-	
V13	VCCAUX	-		VCCAUX	-	
V22	VCCAUX	-		VCCAUX	-	
V23	VCCAUX	-		VCCAUX	-	

LFSC/M40, LFSC/M80 Logic Signal Connections: 1152 fcBGA^{1,2} (Cont.)

Ball Number	LFSC/M40			LFSC/M80		
	Ball Function	VCCIO Bank	Dual Function	Ball Function	VCCIO Bank	Dual Function
W13	VCCAUX	-		VCCAUX	-	
W22	VCCAUX	-		VCCAUX	-	
Y21	GND	-		GND	-	
Y25	GND	-		GND	-	
C18	VCCIO1	-		VCCIO1	-	
D17	VCCIO1	-		VCCIO1	-	
F16	VCCIO1	-		VCCIO1	-	
G19	VCCIO1	-		VCCIO1	-	
J20	VCCIO1	-		VCCIO1	-	
K12	VCCIO1	-		VCCIO1	-	
K15	VCCIO1	-		VCCIO1	-	
L23	VCCIO1	-		VCCIO1	-	
Y9	GND	-		GND	-	
J9	VCCIO1	-		VCCIO1	-	
E3	VCCIO2	-		VCCIO2	-	
G6	VCCIO2	-		VCCIO2	-	
H4	VCCIO2	-		VCCIO2	-	
K7	VCCIO2	-		VCCIO2	-	
L3	VCCIO2	-		VCCIO2	-	
M11	VCCIO2	-		VCCIO2	-	
N6	VCCIO2	-		VCCIO2	-	
P4	VCCIO2	-		VCCIO2	-	
R9	VCCIO2	-		VCCIO2	-	
AA3	VCCIO3	-		VCCIO3	-	
AB7	VCCIO3	-		VCCIO3	-	
AC10	VCCIO3	-		VCCIO3	-	
AD4	VCCIO3	-		VCCIO3	-	
AE6	VCCIO3	-		VCCIO3	-	
AG3	VCCIO3	-		VCCIO3	-	
AK4	VCCIO3	-		VCCIO3	-	
T7	VCCIO3	-		VCCIO3	-	
U3	VCCIO3	-		VCCIO3	-	
V4	VCCIO3	-		VCCIO3	-	
W6	VCCIO3	-		VCCIO3	-	
Y10	VCCIO3	-		VCCIO3	-	
AD12	VCCIO4	-		VCCIO4	-	
AF15	VCCIO4	-		VCCIO4	-	
AF9	VCCIO4	-		VCCIO4	-	
AH10	VCCIO4	-		VCCIO4	-	
AH16	VCCIO4	-		VCCIO4	-	
AJ13	VCCIO4	-		VCCIO4	-	
AJ7	VCCIO4	-		VCCIO4	-	
AL14	VCCIO4	-		VCCIO4	-	
AL8	VCCIO4	-		VCCIO4	-	
AM11	VCCIO4	-		VCCIO4	-	

LFSC/M40, LFSC/M80 Logic Signal Connections: 1152 fcBGA^{1,2} (Cont.)

Ball Number	LFSC/M40			LFSC/M80		
	Ball Function	VCCIO Bank	Dual Function	Ball Function	VCCIO Bank	Dual Function
AM17	VCCIO4	-		VCCIO4	-	
AM5	VCCIO4	-		VCCIO4	-	
AE20	VCCIO5	-		VCCIO5	-	
AE23	VCCIO5	-		VCCIO5	-	
AE26	VCCIO5	-		VCCIO5	-	
AH22	VCCIO5	-		VCCIO5	-	
AH28	VCCIO5	-		VCCIO5	-	
AJ19	VCCIO5	-		VCCIO5	-	
AJ25	VCCIO5	-		VCCIO5	-	
AL18	VCCIO5	-		VCCIO5	-	
AL24	VCCIO5	-		VCCIO5	-	
AL30	VCCIO5	-		VCCIO5	-	
AM21	VCCIO5	-		VCCIO5	-	
AM27	VCCIO5	-		VCCIO5	-	
AA31	VCCIO6	-		VCCIO6	-	
AB29	VCCIO6	-		VCCIO6	-	
AC24	VCCIO6	-		VCCIO6	-	
AD32	VCCIO6	-		VCCIO6	-	
AE28	VCCIO6	-		VCCIO6	-	
AG31	VCCIO6	-		VCCIO6	-	
AK32	VCCIO6	-		VCCIO6	-	
T29	VCCIO6	-		VCCIO6	-	
U31	VCCIO6	-		VCCIO6	-	
V32	VCCIO6	-		VCCIO6	-	
W28	VCCIO6	-		VCCIO6	-	
Y26	VCCIO6	-		VCCIO6	-	
E31	VCCIO7	-		VCCIO7	-	
G28	VCCIO7	-		VCCIO7	-	
H32	VCCIO7	-		VCCIO7	-	
K29	VCCIO7	-		VCCIO7	-	
L31	VCCIO7	-		VCCIO7	-	
M25	VCCIO7	-		VCCIO7	-	
N28	VCCIO7	-		VCCIO7	-	
P32	VCCIO7	-		VCCIO7	-	
R25	VCCIO7	-		VCCIO7	-	
J25	VCCIO1	-		VCCIO1	-	
N11	VTT_2	2		VTT_2	2	
R12	VTT_2	2		VTT_2	2	
T12	VTT_2	2		VTT_2	2	
AB11	VTT_3	3		VTT_3	3	
W12	VTT_3	3		VTT_3	3	
Y12	VTT_3	3		VTT_3	3	
AC15	VTT_4	4		VTT_4	4	
AC16	VTT_4	4		VTT_4	4	
AD13	VTT_4	4		VTT_4	4	

LFSC/M40, LFSC/M80 Logic Signal Connections: 1152 fcBGA^{1, 2} (Cont.)

Ball Number	LFSC/M40			LFSC/M80		
	Ball Function	VCCIO Bank	Dual Function	Ball Function	VCCIO Bank	Dual Function
AC19	VTT_5	5		VTT_5	5	
AC20	VTT_5	5		VTT_5	5	
AD22	VTT_5	5		VTT_5	5	
AB24	VTT_6	6		VTT_6	6	
W23	VTT_6	6		VTT_6	6	
Y23	VTT_6	6		VTT_6	6	
N24	VTT_7	7		VTT_7	7	
R23	VTT_7	7		VTT_7	7	
T23	VTT_7	7		VTT_7	7	
M12	VDDAX25_R	-		VDDAX25_R	-	
M23	VDDAX25_L	-		VDDAX25_L	-	
Y16	GND	-		GND	-	
Y14	GND	-		GND	-	
N21	VCC12	-		VCC12	-	
P22	VCC12	-		VCC12	-	
AA22	VCC12	-		VCC12	-	
AB21	VCC12	-		VCC12	-	
AB14	VCC12	-		VCC12	-	
AA13	VCC12	-		VCC12	-	
P13	VCC12	-		VCC12	-	
N14	VCC12	-		VCC12	-	
G26	NC	-		NC	-	
G9	NC	-		NC	-	
J12	NC	-		NC	-	
H12	NC	-		NC	-	
H23	NC	-		NC	-	
J23	NC	-		NC	-	

1. Differential pair grouping within a PCI is A (True) and B (complement) and C (True) and D (Complement).
2. The LatticeSC/M40 and LatticeSC/M80 in an 1152-pin package support a 32-bit MPI interface.

LFSC/M115 Logic Signal Connections: 1152 fcBGA^{1,2}

Ball Number	LFSC/M115		
	Ball Function	VCCIO Bank	Dual Function
G27	A_REFCLKP_L	-	
H27	A_REFCLKN_L	-	
H25	VCC12	-	
H26	RESP_ULC	-	
B33	RESETN	1	
C34	TSALLN	1	
D34	DONE	1	
C33	INITN	1	
J27	M0	1	
K27	M1	1	
M26	M2	1	
L26	M3	1	
F30	PL15A	7	ULC_PLLT_IN_A/ULC_PLLT_FB_B
G30	PL15B	7	ULC_PLLC_IN_A/ULC_PLLC_FB_B
H28	PL15C	7	
J28	PL15D	7	
F31	PL17A	7	ULC_DLLT_IN_C/ULC_DLLT_FB_D
G31	PL17B	7	ULC_DLLC_IN_C/ULC_DLLC_FB_D
N25	PL17C	7	ULC_PLLT_IN_B/ULC_PLLT_FB_A
P25	PL17D	7	ULC_PLLC_IN_B/ULC_PLLC_FB_A
D33	PL18A	7	ULC_DLLT_IN_D/ULC_DLLT_FB_C
E33	PL18B	7	ULC_DLLC_IN_D/ULC_DLLC_FB_C
H29	PL18C	7	
J29	PL18D	7	VREF2_7
F32	PL19A	7	
G32	PL19B	7	
P26	PL19C	7	
N26	PL19D	7	
H30	PL26A	7	
J30	PL26B	7	
L28	PL26C	7	
M28	PL26D	7	
J31	PL43A	7	
K31	PL43B	7	
L27	PL43C	7	VREF1_7
M27	PL43D	7	DIFFR_7
J32	PL45A	7	
K32	PL45B	7	
L29	PL45C	7	
M29	PL45D	7	
H33	PL47A	7	
J33	PL47B	7	

LFSC/M115 Logic Signal Connections: 1152 fcBGA^{1, 2}

Ball Number	LFSC/M115		
	Ball Function	VCCIO Bank	Dual Function
N27	PL47C	7	
P27	PL47D	7	
K33	PL49A	7	
L33	PL49B	7	
M30	PL49C	7	
N30	PL49D	7	
M31	PL51A	7	
N31	PL51B	7	
P24	PL51C	7	
R24	PL51D	7	
M33	PL56A	7	
N33	PL56B	7	
U25	PL56C	7	
T25	PL56D	7	
L34	PL57A	7	
M34	PL57B	7	
P29	PL57C	7	
R29	PL57D	7	
N34	PL60A	7	
P34	PL60B	7	
R27	PL60C	7	
T27	PL60D	7	
R32	PL61A	7	PCLKT7_1
R31	PL61B	7	PCLKC7_1
U24	PL61C	7	PCLKT7_3
T24	PL61D	7	PCLKC7_3
P33	PL62A	7	PCLKT7_0
R33	PL62B	7	PCLKC7_0
T26	PL62C	7	PCLKT7_2
U26	PL62D	7	PCLKC7_2
T32	PL64A	6	PCLKT6_0
T31	PL64B	6	PCLKC6_0
U29	PL64C	6	PCLKT6_1
V29	PL64D	6	PCLKC6_1
T30	PL65A	6	
U30	PL65B	6	
U27	PL65C	6	PCLKT6_3
V27	PL65D	6	PCLKC6_3
R34	PL66A	6	
T34	PL66B	6	
U28	PL66C	6	PCLKT6_2
V28	PL66D	6	PCLKC6_2
V30	PL69A	6	

LFSC/M115 Logic Signal Connections: 1152 fcBGA^{1,2}

Ball Number	LFSC/M115		
	Ball Function	VCCIO Bank	Dual Function
W30	PL69B	6	
W27	PL69C	6	VREF1_6
Y27	PL69D	6	
T33	PL70A	6	
U33	PL70B	6	
V25	PL70C	6	
W25	PL70D	6	
U34	PL71A	6	
V34	PL71B	6	
V26	PL71C	6	
W26	PL71D	6	
V33	PL74A	6	
W33	PL74B	6	
V24	PL74C	6	
W24	PL74D	6	
W31	PL77A	6	
Y31	PL77B	6	
Y29	PL77C	6	
AA29	PL77D	6	
Y33	PL79A	6	
AA33	PL79B	6	
Y28	PL79C	6	
AA28	PL79D	6	
AB32	PL90A	6	
AC32	PL90B	6	
AA26	PL90C	6	
AA27	PL90D	6	DIFFR_6
AB31	PL91A	6	
AC31	PL91B	6	
Y24	PL91C	6	
AA24	PL91D	6	
AE34	PL92A	6	
AF34	PL92B	6	
AB30	PL92C	6	
AC30	PL92D	6	
AD33	PL94A	6	
AE33	PL94B	6	
AD30	PL94C	6	
AE30	PL94D	6	
AE32	PL96A	6	
AF32	PL96B	6	
AA25	PL96C	6	
AB25	PL96D	6	

LFSC/M115 Logic Signal Connections: 1152 fcBGA^{1, 2}

Ball Number	LFSC/M115		
	Ball Function	VCCIO Bank	Dual Function
AJ34	PL98A	6	
AK34	PL98B	6	
AB27	PL98C	6	
AC27	PL98D	6	
AF33	PL99A	6	
AG33	PL99B	6	
AC29	PL99C	6	
AD29	PL99D	6	
AE31	PL103A	6	
AF31	PL103B	6	
AF30	PL103C	6	
AF29	PL103D	6	
AH33	PL104A	6	
AJ33	PL104B	6	
AC28	PL104C	6	
AD28	PL104D	6	
AH32	PL107A	6	
AJ32	PL107B	6	
AD27	PL107C	6	
AE27	PL107D	6	VREF2_6
AG34	PL109A	6	
AH34	PL109B	6	
AC26	PL109C	6	
AB26	PL109D	6	
AK33	PL112A	6	
AL33	PL112B	6	
AG30	PL112C	6	
AH30	PL112D	6	
AL34	PL115A	6	
AM34	PL115B	6	
AJ30	PL115C	6	LLC_DLLT_IN_E/LLC_DLLT_FB_F
AK30	PL115D	6	LLC_DLLC_IN_E/LLC_DLLC_FB_F
AJ31	PL116A	6	
AH31	PL116B	6	
AD26	PL116C	6	
AD25	PL116D	6	
AL32	PL117A	6	LLC_DLLT_IN_F/LLC_DLLT_FB_E
AL31	PL117B	6	LLC_DLLC_IN_F/LLC_DLLC_FB_E
AG29	PL117C	6	LLC_PLLT_IN_B/LLC_PLLT_FB_A
AG28	PL117D	6	LLC_PLLC_IN_B/LLC_PLLC_FB_A
AF28	XRES	-	
AF27	TEMP	6	
AM33	PB3A	5	LLC_PLLT_IN_A/LLC_PLLT_FB_B

LFSC/M115 Logic Signal Connections: 1152 fcBGA^{1, 2}

Ball Number	LFSC/M115		
	Ball Function	VCCIO Bank	Dual Function
AN33	PB3B	5	LLC_PLLC_IN_A/LLC_PLLC_FB_B
AH29	PB3C	5	LLC_DLLT_IN_C/LLC_DLLT_FB_D
AJ29	PB3D	5	LLC_DLLC_IN_C/LLC_DLLC_FB_D
AM32	PB4A	5	LLC_DLLT_IN_D/LLC_DLLT_FB_C
AM31	PB4B	5	LLC_DLLC_IN_D/LLC_DLLC_FB_C
AG27	PB4C	5	
AG26	PB4D	5	
AL29	PB5A	5	
AL28	PB5B	5	
AH27	PB5C	5	
AH26	PB5D	5	VREF1_5
AN32	PB7A	5	
AP32	PB7B	5	
AF25	PB7C	5	
AE25	PB7D	5	
AN31	PB11A	5	
AN30	PB11B	5	
AK29	PB11C	5	
AK28	PB11D	5	
AP31	PB12A	5	
AP30	PB12B	5	
AD24	PB12C	5	
AE24	PB12D	5	
AM29	PB15A	5	
AM28	PB15B	5	
AJ27	PB15C	5	
AJ26	PB15D	5	
AP29	PB16A	5	
AP28	PB16B	5	
AK27	PB16C	5	
AK26	PB16D	5	
AN29	PB19A	5	
AN28	PB19B	5	
AG25	PB19C	5	
AG24	PB19D	5	
AL26	PB20A	5	
AL25	PB20B	5	
AG23	PB20C	5	
AG22	PB20D	5	
AN27	PB23A	5	
AN26	PB23B	5	
AF24	PB23C	5	
AF23	PB23D	5	

LFSC/M115 Logic Signal Connections: 1152 fcBGA^{1, 2}

Ball Number	LFSC/M115		
	Ball Function	VCCIO Bank	Dual Function
AP27	PB26A	5	
AP26	PB26B	5	
AK25	PB26C	5	
AK24	PB26D	5	
AN25	PB29A	5	
AN24	PB29B	5	
AE22	PB29C	5	
AE21	PB29D	5	
AM26	PB31A	5	
AM25	PB31B	5	
AF22	PB31C	5	
AF21	PB31D	5	
AN23	PB47A	5	
AN22	PB47B	5	
AP23	PB57A	5	
AP22	PB57B	5	
AG21	PB57C	5	
AG20	PB57D	5	
AP25	PB50A	5	PCLKT5_3
AP24	PB50B	5	PCLKC5_3
AD21	PB50C	5	PCLKT5_4
AD20	PB50D	5	PCLKC5_4
AL23	PB51A	5	PCLKT5_5
AL22	PB51B	5	PCLKC5_5
AH24	PB51C	5	
AH23	PB51D	5	
AM23	PB53A	5	PCLKT5_0
AM22	PB53B	5	PCLKC5_0
AJ24	PB53C	5	
AJ23	PB53D	5	VREF2_5
AN21	PB54A	5	PCLKT5_1
AN20	PB54B	5	PCLKC5_1
AE19	PB54C	5	PCLKT5_6
AD19	PB54D	5	PCLKC5_6
AK21	PB55A	5	PCLKT5_2
AK20	PB55B	5	PCLKC5_2
AK23	PB55C	5	PCLKT5_7
AK22	PB55D	5	PCLKC5_7
AL20	PB58A	5	
AL19	PB58B	5	
AG19	PB58C	5	
AF19	PB58D	5	
AP21	PB61A	5	

LFSC/M115 Logic Signal Connections: 1152 fcBGA^{1, 2}

Ball Number	LFSC/M115		
	Ball Function	VCCIO Bank	Dual Function
AP20	PB61B	5	
AH21	PB61C	5	
AH20	PB61D	5	
AM20	PB63A	5	
AM19	PB63B	5	
AJ21	PB63C	5	
AJ20	PB63D	5	
AK19	PB66A	5	
AK18	PB66B	5	
AE18	PB66C	5	
AD18	PB66D	5	
AN19	PB69A	5	
AN18	PB69B	5	
AG18	PB69C	5	
AF18	PB69D	5	
AP19	PB71A	5	
AP18	PB71B	5	
AJ18	PB71C	5	
AH18	PB71D	5	
AP17	PB73A	4	
AP16	PB73B	4	
AJ17	PB73C	4	
AH17	PB73D	4	
AN17	PB75A	4	
AN16	PB75B	4	
AE17	PB75C	4	
AD17	PB75D	4	
AK17	PB78A	4	
AK16	PB78B	4	
AG17	PB78C	4	
AF17	PB78D	4	
AM16	PB81A	4	
AM15	PB81B	4	
AJ15	PB81C	4	
AJ14	PB81D	4	
AL16	PB83A	4	
AL15	PB83B	4	
AG16	PB83C	4	
AF16	PB83D	4	
AP15	PB86A	4	
AP14	PB86B	4	
AH15	PB86C	4	
AH14	PB86D	4	

LFSC/M115 Logic Signal Connections: 1152 fcBGA^{1, 2}

Ball Number	LFSC/M115		
	Ball Function	VCCIO Bank	Dual Function
AN15	PB89A	4	PCLKT4_2
AN14	PB89B	4	PCLKC4_2
AE16	PB89C	4	PCLKT4_7
AD16	PB89D	4	PCLKC4_7
AK15	PB90A	4	PCLKT4_1
AK14	PB90B	4	PCLKC4_1
AG15	PB90C	4	PCLKT4_6
AG14	PB90D	4	PCLKC4_6
AM13	PB91A	4	PCLKT4_0
AM12	PB91B	4	PCLKC4_0
AJ12	PB91C	4	VREF2_4
AJ11	PB91D	4	
AL13	PB93A	4	PCLKT4_5
AL12	PB93B	4	PCLKC4_5
AH12	PB93C	4	
AH11	PB93D	4	
AN13	PB94A	4	PCLKT4_3
AN12	PB94B	4	PCLKC4_3
AD14	PB94C	4	PCLKT4_4
AD15	PB94D	4	PCLKC4_4
AP13	PB87A	4	
AP12	PB87B	4	
AK13	PB87C	4	
AK12	PB87D	4	
AP11	PB97A	4	
AP10	PB97B	4	
AN11	PB113A	4	
AN10	PB113B	4	
AF14	PB113C	4	
AF13	PB113D	4	
AM10	PB115A	4	
AM9	PB115B	4	
AE14	PB115C	4	
AE13	PB115D	4	
AP9	PB118A	4	
AP8	PB118B	4	
AK11	PB118C	4	
AK10	PB118D	4	
AL10	PB121A	4	
AL9	PB121B	4	
AF12	PB121C	4	
AF11	PB121D	4	
AN9	PB123A	4	

LFSC/M115 Logic Signal Connections: 1152 fcBGA^{1, 2}

Ball Number	LFSC/M115		
	Ball Function	VCCIO Bank	Dual Function
AN8	PB123B	4	
AG11	PB123C	4	
AG10	PB123D	4	
AP7	PB125A	4	
AP6	PB125B	4	
AG13	PB125C	4	
AG12	PB125D	4	
AN7	PB127A	4	
AN6	PB127B	4	
AK9	PB127C	4	
AK8	PB127D	4	
AP5	PB129A	4	
AP4	PB129B	4	
AD11	PB129C	4	
AE11	PB129D	4	
AM7	PB131A	4	
AM6	PB131B	4	
AJ9	PB131C	4	
AJ8	PB131D	4	
AP3	PB133A	4	
AN3	PB133B	4	
AF10	PB133C	4	
AE10	PB133D	4	
AL7	PB135A	4	
AL6	PB135B	4	
AK7	PB135C	4	
AK6	PB135D	4	
AN5	PB138A	4	
AN4	PB138B	4	
AH9	PB138C	4	VREF1_4
AH8	PB138D	4	
AM3	PB139A	4	LRC_DLLT_IN_C/LRC_DLLT_FB_D
AM4	PB139B	4	LRC_DLLC_IN_C/LRC_DLLC_FB_D
AG9	PB139C	4	
AG8	PB139D	4	
AN2	PB141A	4	LRC_PLLT_IN_A/LRC_PLLT_FB_B
AM2	PB141B	4	LRC_PLCC_IN_A/LRC_PLCC_FB_B
AJ6	PB141C	4	LRC_DLLT_IN_D/LRC_DLLT_FB_C
AH6	PB141D	4	LRC_DLLC_IN_D/LRC_DLLC_FB_C
AF7	PROBE_VCC	-	
AF8	PROBE_GND	-	
AG7	PR117D	3	LRC_PLCC_IN_B/LRC_PLCC_FB_A
AG6	PR117C	3	LRC_PLLT_IN_B/LRC_PLLT_FB_A

LFSC/M115 Logic Signal Connections: 1152 fcBGA^{1, 2}

Ball Number	LFSC/M115		
	Ball Function	VCCIO Bank	Dual Function
AL4	PR117B	3	LRC_DLLC_IN_F/LRC_DLLC_FB_E
AL3	PR117A	3	LRC_DLLT_IN_F/LRC_DLLT_FB_E
AD10	PR116D	3	
AD9	PR116C	3	
AH4	PR116B	3	
AJ4	PR116A	3	
AK5	PR115D	3	LRC_DLLC_IN_E/LRC_DLLC_FB_F
AJ5	PR115C	3	LRC_DLLT_IN_E/LRC_DLLT_FB_F
AM1	PR115B	3	
AL1	PR115A	3	
AH5	PR112D	3	
AG5	PR112C	3	
AL2	PR112B	3	
AK2	PR112A	3	
AB9	PR109D	3	
AC9	PR109C	3	
AH1	PR109B	3	
AG1	PR109A	3	
AE8	PR107D	3	VREF2_3
AD8	PR107C	3	
AJ3	PR107B	3	
AH3	PR107A	3	
AD7	PR104D	3	
AC7	PR104C	3	
AJ2	PR104B	3	
AH2	PR104A	3	
AF6	PR103D	3	
AF5	PR103C	3	
AF4	PR103B	3	
AE4	PR103A	3	
AD6	PR99D	3	
AC6	PR99C	3	
AG2	PR99B	3	
AF2	PR99A	3	
AC8	PR98D	3	
AB8	PR98C	3	
AK1	PR98B	3	
AJ1	PR98A	3	
AB10	PR96D	3	
AA10	PR96C	3	
AF3	PR96B	3	
AE3	PR96A	3	
AE5	PR94D	3	

LFSC/M115 Logic Signal Connections: 1152 fcBGA^{1, 2}

Ball Number	LFSC/M115		
	Ball Function	VCCIO Bank	Dual Function
AD5	PR94C	3	
AE2	PR94B	3	
AD2	PR94A	3	
AC5	PR92D	3	
AB5	PR92C	3	
AF1	PR92B	3	
AE1	PR92A	3	
AA11	PR91D	3	
Y11	PR91C	3	
AC4	PR91B	3	
AB4	PR91A	3	
AA8	PR90D	3	DIFFR_3
AA9	PR90C	3	
AC3	PR90B	3	
AB3	PR90A	3	
AA7	PR79D	3	
Y7	PR79C	3	
AA2	PR79B	3	
Y2	PR79A	3	
AA6	PR77D	3	
Y6	PR77C	3	
Y4	PR77B	3	
W4	PR77A	3	
W11	PR74D	3	
V11	PR74C	3	
W2	PR74B	3	
V2	PR74A	3	
W9	PR71D	3	
V9	PR71C	3	
V1	PR71B	3	
U1	PR71A	3	
W10	PR70D	3	
V10	PR70C	3	
U2	PR70B	3	
T2	PR70A	3	
Y8	PR69D	3	
W8	PR69C	3	VREF1_3
W5	PR69B	3	
V5	PR69A	3	
V7	PR66D	3	PCLKC3_2
U7	PR66C	3	PCLKT3_2
T1	PR66B	3	
R1	PR66A	3	

LFSC/M115 Logic Signal Connections: 1152 fcBGA^{1,2}

Ball Number	LFSC/M115		
	Ball Function	VCCIO Bank	Dual Function
V8	PR65D	3	PCLKC3_3
U8	PR65C	3	PCLKT3_3
U5	PR65B	3	
T5	PR65A	3	
V6	PR64D	3	PCLKC3_1
U6	PR64C	3	PCLKT3_1
T4	PR64B	3	PCLKC3_0
T3	PR64A	3	PCLKT3_0
U9	PR62D	2	PCLKC2_2
T9	PR62C	2	PCLKT2_2
R2	PR62B	2	PCLKC2_0
P2	PR62A	2	PCLKT2_0
T11	PR61D	2	PCLKC2_3
U11	PR61C	2	PCLKT2_3
R4	PR61B	2	PCLKC2_1
R3	PR61A	2	PCLKT2_1
T8	PR60D	2	
R8	PR60C	2	
P1	PR60B	2	
N1	PR60A	2	
R6	PR57D	2	
P6	PR57C	2	
M1	PR57B	2	
L1	PR57A	2	
T10	PR56D	2	
U10	PR56C	2	
N2	PR56B	2	
M2	PR56A	2	
R11	PR51D	2	
P11	PR51C	2	
N4	PR51B	2	
M4	PR51A	2	
N5	PR49D	2	
M5	PR49C	2	
L2	PR49B	2	
K2	PR49A	2	
P8	PR47D	2	
N8	PR47C	2	
J2	PR47B	2	
H2	PR47A	2	
M6	PR45D	2	
L6	PR45C	2	
K3	PR45B	2	

LFSC/M115 Logic Signal Connections: 1152 fcBGA^{1,2}

Ball Number	LFSC/M115		
	Ball Function	VCCIO Bank	Dual Function
J3	PR45A	2	
M8	PR43D	2	DIFFR_2
L8	PR43C	2	VREF1_2
K4	PR43B	2	
J4	PR43A	2	
M7	PR26D	2	
L7	PR26C	2	
J5	PR26B	2	
H5	PR26A	2	
N9	PR19D	2	
P9	PR19C	2	
G3	PR19B	2	
F3	PR19A	2	
J6	PR18D	2	VREF2_2
H6	PR18C	2	
E2	PR18B	2	URC_DLLC_IN_D/URC_DLLC_FB_C
D2	PR18A	2	URC_DLLT_IN_D/URC_DLLT_FB_C
P10	PR17D	2	URC_PLLC_IN_B/URC_PLLC_FB_A
N10	PR17C	2	URC_PLLT_IN_B/URC_PLLT_FB_A
G4	PR17B	2	URC_DLLC_IN_C/URC_DLLC_FB_D
F4	PR17A	2	URC_DLLT_IN_C/URC_DLLT_FB_D
J7	PR15D	2	
H7	PR15C	2	
G5	PR15B	2	URC_PLLC_IN_A/URC_PLLC_FB_B
F5	PR15A	2	URC_PLLT_IN_A/URC_PLLT_FB_B
C2	VCCJ	-	
M9	TDO	-	TDO
L9	TMS	-	
D1	TCK	-	
C1	TDI	-	
J8	PROGRAMN	1	
K8	MPIIRQN	1	CFGIRQN/MPI_IRQ_N
B2	CCLK	1	
H9	RESP_URC	-	
H10	VCC12	-	
H8	A_REFCLKN_R	-	
G8	A_REFCLKP_R	-	
C3	VCC12	-	
D3	A_VDDIB0_R	-	
A3	A_HDINP0_R	-	PCS 3E0 CH 0 IN P
B3	A_HDINN0_R	-	PCS 3E0 CH 0 IN N
E5	VCC12	-	
A4	A_HDOUTP0_R	-	PCS 3E0 CH 0 OUT P

LFSC/M115 Logic Signal Connections: 1152 fcBGA^{1,2}

Ball Number	LFSC/M115		
	Ball Function	VCCIO Bank	Dual Function
F6	A_VDDOB0_R	-	
B4	A_HDOUTN0_R	-	PCS 3E0 CH 0 OUT N
F7	A_VDDOB1_R	-	
B5	A_HDOUTN1_R	-	PCS 3E0 CH 1 OUT N
E6	VCC12	-	
A5	A_HDOUTP1_R	-	PCS 3E0 CH 1 OUT P
B6	A_HDINN1_R	-	PCS 3E0 CH 1 IN N
A6	A_HDINP1_R	-	PCS 3E0 CH 1 IN P
C6	VCC12	-	
D4	A_VDDIB1_R	-	
C7	VCC12	-	
D5	A_VDDIB2_R	-	
A7	A_HDINP2_R	-	PCS 3E0 CH 2 IN P
B7	A_HDINN2_R	-	PCS 3E0 CH 2 IN N
E7	VCC12	-	
A8	A_HDOUTP2_R	-	PCS 3E0 CH 2 OUT P
F8	A_VDDOB2_R	-	
B8	A_HDOUTN2_R	-	PCS 3E0 CH 2 OUT N
F9	A_VDDOB3_R	-	
B9	A_HDOUTN3_R	-	PCS 3E0 CH 3 OUT N
E8	VCC12	-	
A9	A_HDOUTP3_R	-	PCS 3E0 CH 3 OUT P
B10	A_HDINN3_R	-	PCS 3E0 CH 3 IN N
A10	A_HDINP3_R	-	PCS 3E0 CH 3 IN P
C10	VCC12	-	
D6	A_VDDIB3_R	-	
G10	VCC12	-	
D7	B_VDDIB0_R	-	
E10	B_HDINP0_R	-	PCS 3E1 CH 0 IN P
F10	B_HDINN0_R	-	PCS 3E1 CH 0 IN N
K10	VCC12	-	
A11	B_HDOUTP0_R	-	PCS 3E1 CH 0 OUT P
D10	B_VDDOB0_R	-	
B11	B_HDOUTN0_R	-	PCS 3E1 CH 0 OUT N
D11	B_VDDOB1_R	-	
B12	B_HDOUTN1_R	-	PCS 3E1 CH 1 OUT N
L10	VCC12	-	
A12	B_HDOUTP1_R	-	PCS 3E1 CH 1 OUT P
F11	B_HDINN1_R	-	PCS 3E1 CH 1 IN N
E11	B_HDINP1_R	-	PCS 3E1 CH 1 IN P
G11	VCC12	-	
D8	B_VDDIB1_R	-	
G12	VCC12	-	

LFSC/M115 Logic Signal Connections: 1152 fcBGA^{1,2}

Ball Number	LFSC/M115		
	Ball Function	VCCIO Bank	Dual Function
D9	B_VDDIB2_R	-	
E12	B_HDINP2_R	-	PCS 3E1 CH 2 IN P
F12	B_HDINN2_R	-	PCS 3E1 CH 2 IN N
K11	VCC12	-	
A13	B_HDOUTP2_R	-	PCS 3E1 CH 2 OUT P
D12	B_VDDOB2_R	-	
B13	B_HDOUTN2_R	-	PCS 3E1 CH 2 OUT N
D13	B_VDDOB3_R	-	
B14	B_HDOUTN3_R	-	PCS 3E1 CH 3 OUT N
L11	VCC12	-	
A14	B_HDOUTP3_R	-	PCS 3E1 CH 3 OUT P
F13	B_HDINN3_R	-	PCS 3E1 CH 3 IN N
E13	B_HDINP3_R	-	PCS 3E1 CH 3 IN P
G13	VCC12	-	
E9	B_VDDIB3_R	-	
L13	VCC12	-	
J11	B_REFCLKN_R	-	
H11	B_REFCLKP_R	-	
M15	PT93D	1	HDC/SI
M16	PT93C	1	LDCN/SCS
F14	PT93B	1	D8/MPI_DATA8
G14	PT93A	1	CS1/MPI_CS1
L15	PT90D	1	D9/MPI_DATA9
L14	PT90C	1	D10/MPI_DATA10
D14	PT90B	1	CS0N/MPI_CS0N
E14	PT90A	1	RDN/MPI_STRB_N
L16	PT89D	1	WRN/MPI_WR_N
K16	PT89C	1	D7/MPI_DATA7
G15	PT89B	1	D6/MPI_DATA6
F15	PT89A	1	D5/MPI_DATA5
K14	PT87D	1	D4/MPI_DATA4
K13	PT87C	1	D3/MPI_DATA3
B15	PT87B	1	D2/MPI_DATA2
A15	PT87A	1	D1/MPI_DATA1
J14	PT86D	1	D16/PCLKC1_3/MPI_DATA16
H14	PT86C	1	D17/PCLKT1_3/MPI_DATA17
A16	PT86B	1	D0/MPI_DATA0
B16	PT86A	1	QOUT/CEON
J13	PT83D	1	VREF2_1
H13	PT83C	1	D18/MPI_DATA18
D15	PT83B	1	DOUT
E15	PT83A	1	MCA_DONE_IN
J16	PT81D	1	D19/PCLKC1_2/MPI_DATA19

LFSC/M115 Logic Signal Connections: 1152 fcBGA^{1, 2}

Ball Number	LFSC/M115		
	Ball Function	VCCIO Bank	Dual Function
J17	PT81C	1	D20/PCLKT1_2/MPI_DATA20
D16	PT81B	1	MCA_CLK_P1_OUT
E16	PT81A	1	MCA_CLK_P1_IN
H15	PT78D	1	D21/PCLKC1_1/MPI_DATA21
H16	PT78C	1	D22/PCLKT1_1/MPI_DATA22
C15	PT78B	1	MCA_CLK_P2_OUT
C16	PT78A	1	MCA_CLK_P2_IN
L17	PT75D	1	MCA_DONE_OUT
K17	PT75C	1	BUSYN/RCLK/SCK
E17	PT75B	1	DP0/MPI_PAR0
F17	PT75A	1	MPI_TA
G17	PT73D	1	D23/MPI_DATA23
H17	PT73C	1	DP2/MPI_PAR2
A17	PT73B	1	PCLKC1_0
B17	PT73A	1	PCLKT1_0/MPI_CLK
G18	PT71D	1	DP3/PCLKC1_4/MPI_PAR3
H18	PT71C	1	D24/PCLKT1_4/MPI_DATA24
E18	PT71B	1	MPI_RETRY
F18	PT71A	1	A0/MPI_ADDR14
J18	PT69D	1	A1/MPI_ADDR15
J19	PT69C	1	A2/MPI_ADDR16
C20	PT69B	1	A3/MPI_ADDR17
C19	PT69A	1	A4/MPI_ADDR18
K18	PT66D	1	D25/PCLKC1_5/MPI_DATA25
L18	PT66C	1	D26/PCLKT1_5/MPI_DATA26
D19	PT66B	1	A5/MPI_ADDR19
E19	PT66A	1	A6/MPI_ADDR20
H19	PT63D	1	D27/MPI_DATA27
H20	PT63C	1	VREF1_1
A18	PT63B	1	A7/MPI_ADDR21
B18	PT63A	1	A8/MPI_ADDR22
H21	PT61D	1	D28/PCLKC1_6/MPI_DATA28
J21	PT61C	1	D29/PCLKT1_6/MPI_DATA29
A19	PT61B	1	A9/MPI_ADDR23
B19	PT61A	1	A10/MPI_ADDR24
H22	PT58D	1	D30/PCLKC1_7/MPI_DATA30
J22	PT58C	1	D31/PCLKT1_7/MPI_DATA31
F20	PT58B	1	A11/MPI_ADDR25
G20	PT58A	1	A12/MPI_ADDR26
K21	PT57D	1	D11/MPI_DATA11
K22	PT57C	1	D12/MPI_DATA12
A20	PT57B	1	A13/MPI_ADDR27
B20	PT57A	1	A14/MPI_ADDR28

LFSC/M115 Logic Signal Connections: 1152 fcBGA^{1, 2}

Ball Number	LFSC/M115		
	Ball Function	VCCIO Bank	Dual Function
L21	PT55D	1	A16/MPI_ADDR30
L20	PT55C	1	D13/MPI_DATA13
D20	PT55B	1	A15/MPI_ADDR29
E20	PT55A	1	A17/MPI_ADDR31
L19	PT54D	1	A19/MPI_TSIZ1
K19	PT54C	1	A20/MPI_BDIP
D21	PT54B	1	A18/MPI_TSIZ0
E21	PT54A	1	MPI_TEA
M20	PT51D	1	D14/MPI_DATA14
M19	PT51C	1	DP1/MPI_PAR1
F21	PT51B	1	A21/MPI_BURST
G21	PT51A	1	D15/MPI_DATA15
H24	B_REFCLKP_L	-	
J24	B_REFCLKN_L	-	
L22	VCC12	-	
E26	B_VDDIB3_L	-	
G22	VCC12	-	
E22	B_HDINP3_L	-	PCS 361 CH 3 IN P
F22	B_HDINN3_L	-	PCS 361 CH 3 IN N
A21	B_HDOUTP3_L	-	PCS 361 CH 3 OUT P
L24	VCC12	-	
B21	B_HDOUTN3_L	-	PCS 361 CH 3 OUT N
D22	B_VDDOB3_L	-	
B22	B_HDOUTN2_L	-	PCS 361 CH 2 OUT N
D23	B_VDDOB2_L	-	
A22	B_HDOUTP2_L	-	PCS 361 CH 2 OUT P
K24	VCC12	-	
F23	B_HDINN2_L	-	PCS 361 CH 2 IN N
E23	B_HDINP2_L	-	PCS 361 CH 2 IN P
D26	B_VDDIB2_L	-	
G23	VCC12	-	
D27	B_VDDIB1_L	-	
G24	VCC12	-	
E24	B_HDINP1_L	-	PCS 361 CH 1 IN P
F24	B_HDINN1_L	-	PCS 361 CH 1 IN N
A23	B_HDOUTP1_L	-	PCS 361 CH 1 OUT P
L25	VCC12	-	
B23	B_HDOUTN1_L	-	PCS 361 CH 1 OUT N
D24	B_VDDOB1_L	-	
B24	B_HDOUTN0_L	-	PCS 361 CH 0 OUT N
D25	B_VDDOB0_L	-	
A24	B_HDOUTP0_L	-	PCS 361 CH 0 OUT P
K25	VCC12	-	

LFSC/M115 Logic Signal Connections: 1152 fcBGA^{1, 2}

Ball Number	LFSC/M115		
	Ball Function	VCCIO Bank	Dual Function
F25	B_HDINN0_L	-	PCS 361 CH 0 IN N
E25	B_HDINP0_L	-	PCS 361 CH 0 IN P
D28	B_VDDIB0_L	-	
G25	VCC12	-	
D29	A_VDDIB3_L	-	
C25	VCC12	-	
A25	A_HDINP3_L	-	PCS 360 CH 3 IN P
B25	A_HDINN3_L	-	PCS 360 CH 3 IN N
A26	A_HDOUTP3_L	-	PCS 360 CH 3 OUT P
E27	VCC12	-	
B26	A_HDOUTN3_L	-	PCS 360 CH 3 OUT N
F26	A_VDDOB3_L	-	
B27	A_HDOUTN2_L	-	PCS 360 CH 2 OUT N
F27	A_VDDOB2_L	-	
A27	A_HDOUTP2_L	-	PCS 360 CH 2 OUT P
E28	VCC12	-	
B28	A_HDINN2_L	-	PCS 360 CH 2 IN N
A28	A_HDINP2_L	-	PCS 360 CH 2 IN P
D30	A_VDDIB2_L	-	
C28	VCC12	-	
D31	A_VDDIB1_L	-	
C29	VCC12	-	
A29	A_HDINP1_L	-	PCS 360 CH 1 IN P
B29	A_HDINN1_L	-	PCS 360 CH 1 IN N
A30	A_HDOUTP1_L	-	PCS 360 CH 1 OUT P
E29	VCC12	-	
B30	A_HDOUTN1_L	-	PCS 360 CH 1 OUT N
F28	A_VDDOB1_L	-	
B31	A_HDOUTN0_L	-	PCS 360 CH 0 OUT N
F29	A_VDDOB0_L	-	
A31	A_HDOUTP0_L	-	PCS 360 CH 0 OUT P
E30	VCC12	-	
B32	A_HDINN0_L	-	PCS 360 CH 0 IN N
A32	A_HDINP0_L	-	PCS 360 CH 0 IN P
D32	A_VDDIB0_L	-	
C32	VCC12	-	
E34	PL30A	7	
F34	PL30B	7	
F33	PL34A	7	
G33	PL34B	7	
K30	PL38A	7	
L30	PL38B	7	
G34	PL40A	7	

LFSC/M115 Logic Signal Connections: 1152 fcBGA^{1, 2}

Ball Number	LFSC/M115		
	Ball Function	VCCIO Bank	Dual Function
H34	PL40B	7	
M32	PL53A	7	
N32	PL53B	7	
P28	PL53C	7	
R28	PL53D	7	
J34	PL55A	7	
K34	PL55B	7	
P30	PL55C	7	
R30	PL55D	7	
W34	PL73A	6	
Y34	PL73B	6	
W32	PL75A	6	
Y32	PL75B	6	
AA34	PL78A	6	
AB34	PL78B	6	
AC34	PL81A	6	
AD34	PL81B	6	
Y30	PL82A	6	
AA30	PL82B	6	
AB33	PL83A	6	
AC33	PL83B	6	
AC2	PR83B	3	
AB2	PR83A	3	
AA5	PR82B	3	
Y5	PR82A	3	
AD1	PR81B	3	
AC1	PR81A	3	
AB1	PR78B	3	
AA1	PR78A	3	
Y3	PR75B	3	
W3	PR75A	3	
Y1	PR73B	3	
W1	PR73A	3	
R5	PR55D	2	
P5	PR55C	2	
K1	PR55B	2	
J1	PR55A	2	
R7	PR53D	2	
P7	PR53C	2	
N3	PR53B	2	
M3	PR53A	2	
H1	PR40B	2	
G1	PR40A	2	

LFSC/M115 Logic Signal Connections: 1152 fcBGA^{1,2}

Ball Number	LFSC/M115		
	Ball Function	VCCIO Bank	Dual Function
L5	PR38B	2	
K5	PR38A	2	
G2	PR34B	2	
F2	PR34A	2	
F1	PR30B	2	
E1	PR30A	2	
A2	GND	-	
A33	GND	-	
AA15	GND	-	
AA20	GND	-	
AA32	GND	-	
AA4	GND	-	
AB28	GND	-	
AB6	GND	-	
AC11	GND	-	
AC18	GND	-	
AC25	GND	-	
AD23	GND	-	
AD3	GND	-	
AD31	GND	-	
AE12	GND	-	
AE15	GND	-	
AE29	GND	-	
AE7	GND	-	
AE9	GND	-	
AF20	GND	-	
AF26	GND	-	
AG32	GND	-	
AG4	GND	-	
AH13	GND	-	
AH19	GND	-	
AH25	GND	-	
AH7	GND	-	
AJ10	GND	-	
AJ16	GND	-	
AJ22	GND	-	
AJ28	GND	-	
AK3	GND	-	
AK31	GND	-	
AL11	GND	-	
AL17	GND	-	
AL21	GND	-	
AL27	GND	-	

LFSC/M115 Logic Signal Connections: 1152 fcBGA^{1, 2}

Ball Number	LFSC/M115		
	Ball Function	VCCIO Bank	Dual Function
AL5	GND	-	
AM14	GND	-	
AM18	GND	-	
AM24	GND	-	
AM30	GND	-	
AM8	GND	-	
AN1	GND	-	
AN34	GND	-	
AP2	GND	-	
AP33	GND	-	
B1	GND	-	
B34	GND	-	
C11	GND	-	
C12	GND	-	
C13	GND	-	
C14	GND	-	
C17	GND	-	
C21	GND	-	
C22	GND	-	
C23	GND	-	
C24	GND	-	
C26	GND	-	
C27	GND	-	
C30	GND	-	
C31	GND	-	
C4	GND	-	
C5	GND	-	
C8	GND	-	
C9	GND	-	
D18	GND	-	
E32	GND	-	
E4	GND	-	
F19	GND	-	
G16	GND	-	
G29	GND	-	
G7	GND	-	
H3	GND	-	
H31	GND	-	
J10	GND	-	
J15	GND	-	
J26	GND	-	
K20	GND	-	
K23	GND	-	

LFSC/M115 Logic Signal Connections: 1152 fcBGA^{1, 2}

Ball Number	LFSC/M115		
	Ball Function	VCCIO Bank	Dual Function
K26	GND	-	
K28	GND	-	
K6	GND	-	
K9	GND	-	
L12	GND	-	
L32	GND	-	
L4	GND	-	
M10	GND	-	
M17	GND	-	
M24	GND	-	
N29	GND	-	
N7	GND	-	
P15	GND	-	
P20	GND	-	
P3	GND	-	
P31	GND	-	
R10	GND	-	
R14	GND	-	
R16	GND	-	
R19	GND	-	
R21	GND	-	
R26	GND	-	
T15	GND	-	
T17	GND	-	
T18	GND	-	
T20	GND	-	
T28	GND	-	
T6	GND	-	
U16	GND	-	
U19	GND	-	
U23	GND	-	
U32	GND	-	
U4	GND	-	
V12	GND	-	
V16	GND	-	
V19	GND	-	
V3	GND	-	
V31	GND	-	
W15	GND	-	
W17	GND	-	
W18	GND	-	
W20	GND	-	
W29	GND	-	

LFSC/M115 Logic Signal Connections: 1152 fcBGA^{1, 2}

Ball Number	LFSC/M115		
	Ball Function	VCCIO Bank	Dual Function
W7	GND	-	
AA14	VCC	-	
AA16	VCC	-	
AA17	VCC	-	
AA18	VCC	-	
AA19	VCC	-	
AA21	VCC	-	
AB13	VCC	-	
AB22	VCC	-	
N13	VCC	-	
N22	VCC	-	
P14	VCC	-	
P16	VCC	-	
P17	VCC	-	
P18	VCC	-	
P19	VCC	-	
P21	VCC	-	
R15	VCC	-	
R17	VCC	-	
R18	VCC	-	
R20	VCC	-	
T14	VCC	-	
T16	VCC	-	
T19	VCC	-	
T21	VCC	-	
U14	VCC	-	
U15	VCC	-	
U17	VCC	-	
U18	VCC	-	
U20	VCC	-	
U21	VCC	-	
V14	VCC	-	
V15	VCC	-	
V17	VCC	-	
V18	VCC	-	
V20	VCC	-	
V21	VCC	-	
W14	VCC	-	
W16	VCC	-	
W19	VCC	-	
W21	VCC	-	
Y15	VCC	-	
Y17	VCC	-	

LFSC/M115 Logic Signal Connections: 1152 fcBGA^{1, 2}

Ball Number	LFSC/M115		
	Ball Function	VCCIO Bank	Dual Function
Y18	VCC	-	
Y20	VCC	-	
AB15	VCC12	-	
AB20	VCC12	-	
N15	VCC12	-	
N20	VCC12	-	
R13	VCC12	-	
R22	VCC12	-	
Y13	VCC12	-	
Y22	VCC12	-	
AA12	VCCAUX	-	
AA23	VCCAUX	-	
AB12	VCCAUX	-	
AB16	VCCAUX	-	
AB17	VCCAUX	-	
AB18	VCCAUX	-	
AB19	VCCAUX	-	
AB23	VCCAUX	-	
AC12	VCCAUX	-	
AC13	VCCAUX	-	
Y19	GND	-	
AC14	VCCAUX	-	
AC17	VCCAUX	-	
AC21	VCCAUX	-	
AC22	VCCAUX	-	
AC23	VCCAUX	-	
M13	VCCAUX	-	
M14	VCCAUX	-	
M18	VCCAUX	-	
M21	VCCAUX	-	
M22	VCCAUX	-	
N12	VCCAUX	-	
N16	VCCAUX	-	
N17	VCCAUX	-	
N18	VCCAUX	-	
N19	VCCAUX	-	
N23	VCCAUX	-	
P12	VCCAUX	-	
P23	VCCAUX	-	
T13	VCCAUX	-	
T22	VCCAUX	-	
U12	VCCAUX	-	
U13	VCCAUX	-	

LFSC/M115 Logic Signal Connections: 1152 fcBGA^{1, 2}

Ball Number	LFSC/M115		
	Ball Function	VCCIO Bank	Dual Function
U22	VCCAUX	-	
V13	VCCAUX	-	
V22	VCCAUX	-	
V23	VCCAUX	-	
W13	VCCAUX	-	
W22	VCCAUX	-	
Y21	GND	-	
Y25	GND	-	
C18	VCCIO1	-	
D17	VCCIO1	-	
F16	VCCIO1	-	
G19	VCCIO1	-	
J20	VCCIO1	-	
K12	VCCIO1	-	
K15	VCCIO1	-	
L23	VCCIO1	-	
Y9	GND	-	
J9	VCCIO1	-	
E3	VCCIO2	-	
G6	VCCIO2	-	
H4	VCCIO2	-	
K7	VCCIO2	-	
L3	VCCIO2	-	
M11	VCCIO2	-	
N6	VCCIO2	-	
P4	VCCIO2	-	
R9	VCCIO2	-	
AA3	VCCIO3	-	
AB7	VCCIO3	-	
AC10	VCCIO3	-	
AD4	VCCIO3	-	
AE6	VCCIO3	-	
AG3	VCCIO3	-	
AK4	VCCIO3	-	
T7	VCCIO3	-	
U3	VCCIO3	-	
V4	VCCIO3	-	
W6	VCCIO3	-	
Y10	VCCIO3	-	
AD12	VCCIO4	-	
AF15	VCCIO4	-	
AF9	VCCIO4	-	
AH10	VCCIO4	-	

LFSC/M115 Logic Signal Connections: 1152 fcBGA^{1, 2}

Ball Number	LFSC/M115		
	Ball Function	VCCIO Bank	Dual Function
AH16	VCCIO4	-	
AJ13	VCCIO4	-	
AJ7	VCCIO4	-	
AL14	VCCIO4	-	
AL8	VCCIO4	-	
AM11	VCCIO4	-	
AM17	VCCIO4	-	
AM5	VCCIO4	-	
AE20	VCCIO5	-	
AE23	VCCIO5	-	
AE26	VCCIO5	-	
AH22	VCCIO5	-	
AH28	VCCIO5	-	
AJ19	VCCIO5	-	
AJ25	VCCIO5	-	
AL18	VCCIO5	-	
AL24	VCCIO5	-	
AL30	VCCIO5	-	
AM21	VCCIO5	-	
AM27	VCCIO5	-	
AA31	VCCIO6	-	
AB29	VCCIO6	-	
AC24	VCCIO6	-	
AD32	VCCIO6	-	
AE28	VCCIO6	-	
AG31	VCCIO6	-	
AK32	VCCIO6	-	
T29	VCCIO6	-	
U31	VCCIO6	-	
V32	VCCIO6	-	
W28	VCCIO6	-	
Y26	VCCIO6	-	
E31	VCCIO7	-	
G28	VCCIO7	-	
H32	VCCIO7	-	
K29	VCCIO7	-	
L31	VCCIO7	-	
M25	VCCIO7	-	
N28	VCCIO7	-	
P32	VCCIO7	-	
R25	VCCIO7	-	
J25	VCCIO1	-	
N11	VTT_2	2	

LFSC/M115 Logic Signal Connections: 1152 fcBGA^{1, 2}

Ball Number	LFSC/M115		
	Ball Function	VCCIO Bank	Dual Function
R12	VTT_2	2	
T12	VTT_2	2	
AB11	VTT_3	3	
W12	VTT_3	3	
Y12	VTT_3	3	
AC15	VTT_4	4	
AC16	VTT_4	4	
AD13	VTT_4	4	
AC19	VTT_5	5	
AC20	VTT_5	5	
AD22	VTT_5	5	
AB24	VTT_6	6	
W23	VTT_6	6	
Y23	VTT_6	6	
N24	VTT_7	7	
R23	VTT_7	7	
T23	VTT_7	7	
M12	VDDAX25_R	-	
M23	VDDAX25_L	-	
Y16	GND	-	
Y14	GND	-	
N21	VCC12	-	
P22	VCC12	-	
AA22	VCC12	-	
AB21	VCC12	-	
AB14	VCC12	-	
AA13	VCC12	-	
P13	VCC12	-	
N14	VCC12	-	
G26	NC	-	
G9	NC	-	
J12	NC	-	
H12	NC	-	
H23	NC	-	
J23	NC	-	

1. Differential pair grouping within a PCI is A (True) and B (complement) and C (True) and D (Complement).
 2. The LatticeSC/M115 in an 1152-pin package supports a 32-bit MPI interface.

LFSC/M80, LFSC/M115 Logic Signal Connections: 1704 fcBGA^{1,2}

Ball Number	LFSC/M80			LFSC/M115		
	Ball Function	VCCIO Bank	Dual Function	Ball Function	VCCIO Bank	Dual Function
G34	A_REFCLKP_L	-		A_REFCLKP_L	-	
H34	A_REFCLKN_L	-		A_REFCLKN_L	-	
N30	VCC12	-		VCC12	-	
H33	RESP_ULC	-		RESP_ULC	-	
P25	RESETN	1		RESETN	1	
P26	TSALLN	1		TSALLN	1	
P31	DONE	1		DONE	1	
P23	INITN	1		INITN	1	
P30	M0	1		M0	1	
P22	M1	1		M1	1	
P24	M2	1		M2	1	
R22	M3	1		M3	1	
J37	PL16A	7	ULC_PLLT_IN_A/ULC_PLLT_FB_B	PL15A	7	ULC_PLLT_IN_A/ULC_PLLT_FB_B
J38	PL16B	7	ULC_PLLC_IN_A/ULC_PLLC_FB_B	PL15B	7	ULC_PLLC_IN_A/ULC_PLLC_FB_B
P32	PL16C	7		PL15C	7	
R32	PL16D	7		PL15D	7	
G40	PL17A	7	ULC_DLLT_IN_C/ULC_DLLT_FB_D	PL17A	7	ULC_DLLT_IN_C/ULC_DLLT_FB_D
H40	PL17B	7	ULC_DLLC_IN_C/ULC_DLLC_FB_D	PL17B	7	ULC_DLLC_IN_C/ULC_DLLC_FB_D
N33	PL17C	7	ULC_PLLT_IN_B/ULC_PLLT_FB_A	PL17C	7	ULC_PLLT_IN_B/ULC_PLLT_FB_A
P33	PL17D	7	ULC_PLLC_IN_B/ULC_PLLC_FB_A	PL17D	7	ULC_PLLC_IN_B/ULC_PLLC_FB_A
G41	PL18A	7	ULC_DLLT_IN_D/ULC_DLLT_FB_C	PL18A	7	ULC_DLLT_IN_D/ULC_DLLT_FB_C
H41	PL18B	7	ULC_DLLC_IN_D/ULC_DLLC_FB_C	PL18B	7	ULC_DLLC_IN_D/ULC_DLLC_FB_C
T29	PL18C	7		PL18C	7	
U29	PL18D	7	VREF2_7	PL18D	7	VREF2_7
G42	PL20A	7		PL19A	7	
H42	PL20B	7		PL19B	7	
M34	PL20C	7		PL19C	7	
M35	PL20D	7		PL19D	7	
K37	PL21A	7		PL26A	7	
L37	PL21B	7		PL26B	7	
N34	PL21C	7		PL26C	7	
P34	PL21D	7		PL26D	7	
K38	PL22A	7		PL30A	7	
L38	PL22B	7		PL30B	7	
T33	PL22C	7		PL30C	7	
R33	PL22D	7		PL30D	7	
J41	PL24A	7		PL34A	7	
K41	PL24B	7		PL34B	7	
U31	PL24C	7		PL34C	7	
V31	PL24D	7		PL34D	7	
K42	PL25A	7		PL38A	7	
J42	PL25B	7		PL38B	7	
J36	PL25C	7		PL38C	7	
K36	PL25D	7		PL38D	7	
N38	PL26A	7		PL40A	7	

LFSC/M80, LFSC/M115 Logic Signal Connections: 1704 fcBGA^{1,2} (Cont.)

Ball Number	LFSC/M80			LFSC/M115		
	Ball Function	VCCIO Bank	Dual Function	Ball Function	VCCIO Bank	Dual Function
P38	PL26B	7		PL40B	7	
N35	PL26C	7		PL40C	7	
N36	PL26D	7		PL40D	7	
N39	PL29A	7		PL43A	7	
P39	PL29B	7		PL43B	7	
R34	PL29C	7	VREF1_7	PL43C	7	VREF1_7
T34	PL29D	7	DIFFR_7	PL43D	7	DIFFR_7
L41	PL30A	7		PL44A	7	
M41	PL30B	7		PL44B	7	
W29	PL30C	7		PL44C	7	
Y29	PL30D	7		PL44D	7	
L42	PL31A	7		PL45A	7	
M42	PL31B	7		PL45B	7	
U32	PL31C	7		PL45C	7	
V32	PL31D	7		PL45D	7	
R37	PL33A	7		PL47A	7	
T37	PL33B	7		PL47B	7	
M36	PL33C	7		PL47C	7	
M37	PL33D	7		PL47D	7	
P40	PL34A	7		PL48A	7	
N40	PL34B	7		PL48B	7	
R35	PL34C	7		PL48C	7	
T35	PL34D	7		PL48D	7	
N41	PL35A	7		PL49A	7	
P41	PL35B	7		PL49B	7	
V33	PL35C	7		PL49C	7	
U33	PL35D	7		PL49D	7	
R38	PL37A	7		PL51A	7	
T38	PL37B	7		PL51B	7	
R36	PL37C	7		PL51C	7	
T36	PL37D	7		PL51D	7	
N42	PL38A	7		PL52A	7	
P42	PL38B	7		PL52B	7	
Y31	PL38C	7		PL52C	7	
AA31	PL38D	7		PL52D	7	
U37	PL39A	7		PL53A	7	
V37	PL39B	7		PL53B	7	
U34	PL39C	7		PL53C	7	
V34	PL39D	7		PL53D	7	
U39	PL41A	7		PL55A	7	
T39	PL41B	7		PL55B	7	
V35	PL41C	7		PL55C	7	
W35	PL41D	7		PL55D	7	
R41	PL42A	7		PL56A	7	
T41	PL42B	7		PL56B	7	

LFSC/M80, LFSC/M115 Logic Signal Connections: 1704 fcBGA^{1,2} (Cont.)

Ball Number	LFSC/M80			LFSC/M115		
	Ball Function	VCCIO Bank	Dual Function	Ball Function	VCCIO Bank	Dual Function
W33	PL42C	7		PL56C	7	
Y33	PL42D	7		PL56D	7	
W37	PL43A	7		PL57A	7	
Y37	PL43B	7		PL57B	7	
Y32	PL43C	7		PL57C	7	
AA32	PL43D	7		PL57D	7	
U38	PL46A	7		PL60A	7	
V38	PL46B	7		PL60B	7	
W34	PL46C	7		PL60C	7	
Y34	PL46D	7		PL60D	7	
T40	PL47A	7	PCLKT7_1	PL61A	7	PCLKT7_1
U40	PL47B	7	PCLKC7_1	PL61B	7	PCLKC7_1
AA33	PL47C	7	PCLKT7_3	PL61C	7	PCLKT7_3
AB33	PL47D	7	PCLKC7_3	PL61D	7	PCLKC7_3
R42	PL48A	7	PCLKT7_0	PL62A	7	PCLKT7_0
T42	PL48B	7	PCLKC7_0	PL62B	7	PCLKC7_0
AA34	PL48C	7	PCLKT7_2	PL62C	7	PCLKT7_2
AB34	PL48D	7	PCLKC7_2	PL62D	7	PCLKC7_2
U41	PL50A	6	PCLKT6_0	PL64A	6	PCLKT6_0
V41	PL50B	6	PCLKC6_0	PL64B	6	PCLKC6_0
V36	PL50C	6	PCLKT6_1	PL64C	6	PCLKT6_1
W36	PL50D	6	PCLKC6_1	PL64D	6	PCLKC6_1
U42	PL51A	6		PL65A	6	
V42	PL51B	6		PL65B	6	
AB31	PL51C	6	PCLKT6_3	PL65C	6	PCLKT6_3
AC31	PL51D	6	PCLKC6_3	PL65D	6	PCLKC6_3
W38	PL52A	6		PL66A	6	
Y38	PL52B	6		PL66B	6	
AA35	PL52C	6	PCLKT6_2	PL66C	6	PCLKT6_2
AB35	PL52D	6	PCLKC6_2	PL66D	6	PCLKC6_2
W39	PL55A	6		PL69A	6	
Y39	PL55B	6		PL69B	6	
AB32	PL55C	6	VREF1_6	PL69C	6	VREF1_6
AC32	PL55D	6		PL69D	6	
W40	PL56A	6		PL70A	6	
Y40	PL56B	6		PL70B	6	
AA36	PL56C	6		PL70C	6	
AB36	PL56D	6		PL70D	6	
W41	PL57A	6		PL71A	6	
Y41	PL57B	6		PL71B	6	
AA37	PL57C	6		PL71C	6	
AB37	PL57D	6		PL71D	6	
W42	PL59A	6		PL73A	6	
Y42	PL59B	6		PL73B	6	
AC33	PL59C	6		PL73C	6	

LFSC/M80, LFSC/M115 Logic Signal Connections: 1704 fcBGA^{1,2} (Cont.)

Ball Number	LFSC/M80			LFSC/M115		
	Ball Function	VCCIO Bank	Dual Function	Ball Function	VCCIO Bank	Dual Function
AD33	PL59D	6		PL73D	6	
AA38	PL60A	6		PL74A	6	
AB38	PL60B	6		PL74B	6	
AC29	PL60C	6		PL74C	6	
AD29	PL60D	6		PL74D	6	
AA41	PL61A	6		PL75A	6	
AB41	PL61B	6		PL75B	6	
AC34	PL61C	6		PL75C	6	
AD34	PL61D	6		PL75D	6	
AA42	PL63A	6		PL77A	6	
AB42	PL63B	6		PL77B	6	
AC37	PL63C	6		PL77C	6	
AD37	PL63D	6		PL77D	6	
AC38	PL64A	6		PL78A	6	
AD38	PL64B	6		PL78B	6	
AD36	PL64C	6		PL78C	6	
AE36	PL64D	6		PL78D	6	
AC39	PL65A	6		PL79A	6	
AD39	PL65B	6		PL79B	6	
AD35	PL65C	6		PL79C	6	
AE35	PL65D	6		PL79D	6	
AC40	PL67A	6		PL81A	6	
AD40	PL67B	6		PL81B	6	
AE37	PL67C	6		PL81C	6	
AF37	PL67D	6		PL81D	6	
AC41	PL68A	6		PL82A	6	
AD41	PL68B	6		PL82B	6	
AE34	PL68C	6		PL82C	6	
AF34	PL68D	6		PL82D	6	
AC42	PL69A	6		PL83A	6	
AD42	PL69B	6		PL83B	6	
AE33	PL69C	6		PL83C	6	
AF33	PL69D	6		PL83D	6	
AE38	PL72A	6		PL86A	6	
AF38	PL72B	6		PL86B	6	
AE32	PL72C	6		PL86C	6	
AF32	PL72D	6		PL86D	6	
AE41	PL73A	6		PL87A	6	
AF41	PL73B	6		PL87B	6	
AE31	PL73C	6		PL87C	6	
AF31	PL73D	6		PL87D	6	
AE42	PL74A	6		PL88A	6	
AF42	PL74B	6		PL88B	6	
AG37	PL74C	6		PL88C	6	
AH37	PL74D	6		PL88D	6	

LFSC/M80, LFSC/M115 Logic Signal Connections: 1704 fcBGA^{1,2} (Cont.)

Ball Number	LFSC/M80			LFSC/M115		
	Ball Function	VCCIO Bank	Dual Function	Ball Function	VCCIO Bank	Dual Function
AF40	PL76A	6		PL90A	6	
AG40	PL76B	6		PL90B	6	
AG36	PL76C	6		PL90C	6	
AH36	PL76D	6	DIFFR_6	PL90D	6	DIFFR_6
AF39	PL77A	6		PL91A	6	
AG39	PL77B	6		PL91B	6	
AF29	PL77C	6		PL91C	6	
AG29	PL77D	6		PL91D	6	
AH42	PL78A	6		PL92A	6	
AG42	PL78B	6		PL92B	6	
AG35	PL78C	6		PL92C	6	
AH35	PL78D	6		PL92D	6	
AG41	PL80A	6		PL94A	6	
AH41	PL80B	6		PL94B	6	
AG34	PL80C	6		PL94C	6	
AH34	PL80D	6		PL94D	6	
AJ42	PL81A	6		PL96A	6	
AK42	PL81B	6		PL96B	6	
AG33	PL81C	6		PL96C	6	
AH33	PL81D	6		PL96D	6	
AJ41	PL82A	6		PL98A	6	
AK41	PL82B	6		PL98B	6	
AJ37	PL82C	6		PL98C	6	
AK37	PL82D	6		PL98D	6	
AJ40	PL84A	6		PL99A	6	
AK40	PL84B	6		PL99B	6	
AJ34	PL84C	6		PL99C	6	
AK34	PL84D	6		PL99D	6	
AJ38	PL85A	6		PL103A	6	
AK38	PL85B	6		PL103B	6	
AH32	PL85C	6		PL103C	6	
AJ32	PL85D	6		PL103D	6	
AL42	PL86A	6		PL104A	6	
AM42	PL86B	6		PL104B	6	
AK36	PL86C	6		PL104C	6	
AL36	PL86D	6		PL104D	6	
AL38	PL89A	6		PL107A	6	
AM38	PL89B	6		PL107B	6	
AJ33	PL89C	6		PL107C	6	
AK33	PL89D	6	VREF2_6	PL107D	6	VREF2_6
AN42	PL90A	6		PL109A	6	
AP42	PL90B	6		PL109B	6	
AH31	PL90C	6		PL109C	6	
AJ31	PL90D	6		PL109D	6	
AN41	PL91A	6		PL112A	6	

LFSC/M80, LFSC/M115 Logic Signal Connections: 1704 fcBGA^{1,2} (Cont.)

Ball Number	LFSC/M80			LFSC/M115		
	Ball Function	VCCIO Bank	Dual Function	Ball Function	VCCIO Bank	Dual Function
AP41	PL91B	6		PL112B	6	
AK35	PL91C	6		PL112C	6	
AL35	PL91D	6		PL112D	6	
AN38	PL93A	6		PL115A	6	
AP38	PL93B	6		PL115B	6	
AL37	PL93C	6	LLC_DLLT_IN_E/LLC_DLLT_FB_F	PL115C	6	LLC_DLLT_IN_E/LLC_DLLT_FB_F
AM37	PL93D	6	LLC_DLLC_IN_E/LLC_DLLC_FB_F	PL115D	6	LLC_DLLC_IN_E/LLC_DLLC_FB_F
AR41	PL94A	6		PL116A	6	
AT41	PL94B	6		PL116B	6	
AN37	PL94C	6		PL116C	6	
AP37	PL94D	6		PL116D	6	
AR39	PL95A	6	LLC_DLLT_IN_F/LLC_DLLT_FB_E	PL117A	6	LLC_DLLT_IN_F/LLC_DLLT_FB_E
AR40	PL95B	6	LLC_DLLC_IN_F/LLC_DLLC_FB_E	PL117B	6	LLC_DLLC_IN_F/LLC_DLLC_FB_E
AN36	PL95C	6	LLC_PLLT_IN_B/LLC_PLLT_FB_A	PL117C	6	LLC_PLLT_IN_B/LLC_PLLT_FB_A
AP36	PL95D	6	LLC_PLLC_IN_B/LLC_PLLC_FB_A	PL117D	6	LLC_PLLC_IN_B/LLC_PLLC_FB_A
AT40	XRES	-		XRES	-	
AU41	TEMP	6		TEMP	6	
AU42	PB3A	5	LLC_PLLT_IN_A/LLC_PLLT_FB_B	PB3A	5	LLC_PLLT_IN_A/LLC_PLLT_FB_B
AV42	PB3B	5	LLC_PLLC_IN_A/LLC_PLLC_FB_B	PB3B	5	LLC_PLLC_IN_A/LLC_PLLC_FB_B
AL33	PB3C	5	LLC_DLLT_IN_C/LLC_DLLT_FB_D	PB3C	5	LLC_DLLT_IN_C/LLC_DLLT_FB_D
AL34	PB3D	5	LLC_DLLC_IN_C/LLC_DLLC_FB_D	PB3D	5	LLC_DLLC_IN_C/LLC_DLLC_FB_D
AU38	PB4A	5	LLC_DLLT_IN_D/LLC_DLLT_FB_C	PB4A	5	LLC_DLLT_IN_D/LLC_DLLT_FB_C
AV38	PB4B	5	LLC_DLLC_IN_D/LLC_DLLC_FB_C	PB4B	5	LLC_DLLC_IN_D/LLC_DLLC_FB_C
AM34	PB4C	5		PB4C	5	
AM33	PB4D	5		PB4D	5	
AV41	PB5A	5		PB5A	5	
AW41	PB5B	5		PB5B	5	
AK30	PB5C	5		PB5C	5	
AK29	PB5D	5	VREF1_5	PB5D	5	VREF1_5
AW42	PB7A	5		PB7A	5	
AY42	PB7B	5		PB7B	5	
AR37	PB7C	5		PB7C	5	
AR38	PB7D	5		PB7D	5	
AV40	PB8A	5		PB9A	5	
AV39	PB8B	5		PB9B	5	
AN35	PB8C	5		PB9C	5	
AN34	PB8D	5		PB9D	5	
AW40	PB9A	5		PB11A	5	
AY40	PB9B	5		PB11B	5	
AP34	PB9C	5		PB11C	5	
AP35	PB9D	5		PB11D	5	
AW39	PB11A	5		PB12A	5	
AW38	PB11B	5		PB12B	5	
AL32	PB11C	5		PB12C	5	
AL31	PB11D	5		PB12D	5	

LFSC/M80, LFSC/M115 Logic Signal Connections: 1704 fcBGA^{1,2} (Cont.)

Ball Number	LFSC/M80			LFSC/M115		
	Ball Function	VCCIO Bank	Dual Function	Ball Function	VCCIO Bank	Dual Function
AY41	PB12A	5		PB13A	5	
BA41	PB12B	5		PB13B	5	
AT39	PB12C	5		PB13C	5	
AT38	PB12D	5		PB13D	5	
AV37	PB13A	5		PB15A	5	
AV36	PB13B	5		PB15B	5	
AM31	PB13C	5		PB15C	5	
AM32	PB13D	5		PB15D	5	
BA40	PB15A	5		PB16A	5	
BB40	PB15B	5		PB16B	5	
AM29	PB15C	5		PB16C	5	
AL29	PB15D	5		PB16D	5	
AY39	PB16A	5		PB17A	5	
AY38	PB16B	5		PB17B	5	
AN33	PB16C	5		PB17C	5	
AN32	PB16D	5		PB17D	5	
BA39	PB17A	5		PB19A	5	
BA38	PB17B	5		PB19B	5	
AT37	PB17C	5		PB19C	5	
AT36	PB17D	5		PB19D	5	
AW36	PB19A	5		PB20A	5	
AW35	PB19B	5		PB20B	5	
AM28	PB19C	5		PB20C	5	
AL28	PB19D	5		PB20D	5	
BB38	PB20A	5		PB21A	5	
BB39	PB20B	5		PB21B	5	
AR34	PB20C	5		PB21C	5	
AR33	PB20D	5		PB21D	5	
AV35	PB21A	5		PB23A	5	
AV34	PB21B	5		PB23B	5	
AT33	PB21C	5		PB23C	5	
AT34	PB21D	5		PB23D	5	
BA37	PB23A	5		PB25A	5	
BA36	PB23B	5		PB25B	5	
AP33	PB23C	5		PB25C	5	
AP32	PB23D	5		PB25D	5	
AY36	PB24A	5		PB26A	5	
AY35	PB24B	5		PB26B	5	
AN31	PB24C	5		PB26C	5	
AN30	PB24D	5		PB26D	5	
BB37	PB25A	5		PB27A	5	
BB36	PB25B	5		PB27B	5	
AP31	PB25C	5		PB27C	5	
AP30	PB25D	5		PB27D	5	
AV33	PB27A	5		PB29A	5	

LFSC/M80, LFSC/M115 Logic Signal Connections: 1704 fcBGA^{1,2} (Cont.)

Ball Number	LFSC/M80			LFSC/M115		
	Ball Function	VCCIO Bank	Dual Function	Ball Function	VCCIO Bank	Dual Function
AV32	PB27B	5		PB29B	5	
AU36	PB27C	5		PB29C	5	
AU37	PB27D	5		PB29D	5	
BA35	PB28A	5		PB30A	5	
BA34	PB28B	5		PB30B	5	
AJ26	PB28C	5		PB30C	5	
AJ27	PB28D	5		PB30D	5	
AW33	PB29A	5		PB31A	5	
AW32	PB29B	5		PB31B	5	
AU35	PB29C	5		PB31C	5	
AU34	PB29D	5		PB31D	5	
BB35	PB31A	5		PB33A	5	
BB34	PB31B	5		PB33B	5	
AN29	PB31C	5		PB33C	5	
AP29	PB31D	5		PB33D	5	
AY33	PB32A	5		PB34A	5	
AY32	PB32B	5		PB34B	5	
AR31	PB32C	5		PB34C	5	
AR30	PB32D	5		PB34D	5	
AV31	PB33A	5		PB35A	5	
AV30	PB33B	5		PB35B	5	
AN28	PB33C	5		PB35C	5	
AP28	PB33D	5		PB35D	5	
BA33	PB35A	5		PB37A	5	
BA32	PB35B	5		PB37B	5	
AT30	PB35C	5		PB37C	5	
AT31	PB35D	5		PB37D	5	
BB33	PB36A	5		PB38A	5	
BB32	PB36B	5		PB38B	5	
AM26	PB36C	5		PB38C	5	
AL26	PB36D	5		PB38D	5	
AW30	PB37A	5		PB39A	5	
AW29	PB37B	5		PB39B	5	
AP27	PB37C	5		PB39C	5	
AN27	PB37D	5		PB39D	5	
BA31	PB39A	5		PB41A	5	
BA30	PB39B	5		PB41B	5	
AU32	PB39C	5		PB41C	5	
AU33	PB39D	5		PB41D	5	
BB31	PB40A	5		PB42A	5	
BB30	PB40B	5		PB42B	5	
AR28	PB40C	5		PB42C	5	
AR27	PB40D	5		PB42D	5	
AV29	PB41A	5		PB43A	5	
AV28	PB41B	5		PB43B	5	

LFSC/M80, LFSC/M115 Logic Signal Connections: 1704 fcBGA^{1,2} (Cont.)

Ball Number	LFSC/M80			LFSC/M115		
	Ball Function	VCCIO Bank	Dual Function	Ball Function	VCCIO Bank	Dual Function
AP26	PB41C	5		PB43C	5	
AN26	PB41D	5		PB43D	5	
AY30	PB43A	5		PB45A	5	
AY29	PB43B	5		PB45B	5	
AU30	PB43C	5		PB45C	5	
AU31	PB43D	5		PB45D	5	
AV27	PB44A	5		PB46A	5	
AV26	PB44B	5		PB46B	5	
AT28	PB44C	5		PB46C	5	
AT27	PB44D	5		PB46D	5	
BA29	PB45A	5		PB47A	5	
BA28	PB45B	5		PB47B	5	
AL25	PB45C	5		PB47C	5	
AM25	PB45D	5		PB47D	5	
BB29	PB47A	5		PB49A	5	
BB28	PB47B	5		PB49B	5	
AN25	PB47C	5		PB49C	5	
AP25	PB47D	5		PB49D	5	
AY27	PB48A	5	PCLKT5_3	PB50A	5	PCLKT5_3
AY26	PB48B	5	PCLKC5_3	PB50B	5	PCLKC5_3
AT25	PB48C	5	PCLKT5_4	PB50C	5	PCLKT5_4
AT24	PB48D	5	PCLKC5_4	PB50D	5	PCLKC5_4
AW27	PB49A	5	PCLKT5_5	PB51A	5	PCLKT5_5
AW26	PB49B	5	PCLKC5_5	PB51B	5	PCLKC5_5
AU29	PB49C	5		PB51C	5	
AU28	PB49D	5		PB51D	5	
BB27	PB51A	5	PCLKT5_0	PB53A	5	PCLKT5_0
BB26	PB51B	5	PCLKC5_0	PB53B	5	PCLKC5_0
AR25	PB51C	5		PB53C	5	
AR24	PB51D	5	VREF2_5	PB53D	5	VREF2_5
BA27	PB52A	5	PCLKT5_1	PB54A	5	PCLKT5_1
BA26	PB52B	5	PCLKC5_1	PB54B	5	PCLKC5_1
AP24	PB52C	5	PCLKT5_6	PB54C	5	PCLKT5_6
AN24	PB52D	5	PCLKC5_6	PB54D	5	PCLKC5_6
AV25	PB53A	5	PCLKT5_2	PB55A	5	PCLKT5_2
AV24	PB53B	5	PCLKC5_2	PB55B	5	PCLKC5_2
AU27	PB53C	5	PCLKT5_7	PB55C	5	PCLKT5_7
AU26	PB53D	5	PCLKC5_7	PB55D	5	PCLKC5_7
BA25	PB55A	5		PB57A	5	
BA24	PB55B	5		PB57B	5	
AU24	PB55C	5		PB57C	5	
AU25	PB55D	5		PB57D	5	
BB24	PB56A	5		PB58A	5	
BB25	PB56B	5		PB58B	5	
AM23	PB56C	5		PB58C	5	

LFSC/M80, LFSC/M115 Logic Signal Connections: 1704 fcBGA^{1,2} (Cont.)

Ball Number	LFSC/M80			LFSC/M115		
	Ball Function	VCCIO Bank	Dual Function	Ball Function	VCCIO Bank	Dual Function
AL23	PB56D	5		PB58D	5	
AW24	PB57A	5		PB61A	5	
AW23	PB57B	5		PB61B	5	
AN23	PB57C	5		PB61C	5	
AP23	PB57D	5		PB61D	5	
AY23	PB59A	5		PB63A	5	
AY24	PB59B	5		PB63B	5	
AU23	PB59C	5		PB63C	5	
AU22	PB59D	5		PB63D	5	
AV23	PB60A	5		PB66A	5	
AV22	PB60B	5		PB66B	5	
AM22	PB60C	5		PB66C	5	
AL22	PB60D	5		PB66D	5	
BA23	PB61A	5		PB69A	5	
BA22	PB61B	5		PB69B	5	
AN22	PB61C	5		PB69C	5	
AP22	PB61D	5		PB69D	5	
BB23	PB63A	5		PB71A	5	
BB22	PB63B	5		PB71B	5	
AT22	PB63C	5		PB71C	5	
AR22	PB63D	5		PB71D	5	
BB21	PB65A	4		PB73A	4	
BB20	PB65B	4		PB73B	4	
AR21	PB65C	4		PB73C	4	
AT21	PB65D	4		PB73D	4	
BA21	PB66A	4		PB75A	4	
BA20	PB66B	4		PB75B	4	
AP21	PB66C	4		PB75C	4	
AN21	PB66D	4		PB75D	4	
AV21	PB67A	4		PB78A	4	
AV20	PB67B	4		PB78B	4	
AM21	PB67C	4		PB78C	4	
AL21	PB67D	4		PB78D	4	
AY20	PB69A	4		PB81A	4	
AY19	PB69B	4		PB81B	4	
AU21	PB69C	4		PB81C	4	
AU20	PB69D	4		PB81D	4	
AW20	PB70A	4		PB83A	4	
AW19	PB70B	4		PB83B	4	
AP20	PB70C	4		PB83C	4	
AN20	PB70D	4		PB83D	4	
BB19	PB71A	4		PB86A	4	
BB18	PB71B	4		PB86B	4	
AM20	PB71C	4		PB86C	4	
AL20	PB71D	4		PB86D	4	

LFSC/M80, LFSC/M115 Logic Signal Connections: 1704 fcBGA^{1,2} (Cont.)

Ball Number	LFSC/M80			LFSC/M115		
	Ball Function	VCCIO Bank	Dual Function	Ball Function	VCCIO Bank	Dual Function
BA19	PB73A	4		PB87A	4	
BA18	PB73B	4		PB87B	4	
AU19	PB73C	4		PB87C	4	
AU18	PB73D	4		PB87D	4	
AV19	PB74A	4	PCLKT4_2	PB89A	4	PCLKT4_2
AV18	PB74B	4	PCLKC4_2	PB89B	4	PCLKC4_2
AN19	PB74C	4	PCLKT4_7	PB89C	4	PCLKT4_7
AP19	PB74D	4	PCLKC4_7	PB89D	4	PCLKC4_7
BB17	PB75A	4	PCLKT4_1	PB90A	4	PCLKT4_1
BB16	PB75B	4	PCLKC4_1	PB90B	4	PCLKC4_1
AT19	PB75C	4	PCLKT4_6	PB90C	4	PCLKT4_6
AT18	PB75D	4	PCLKC4_6	PB90D	4	PCLKC4_6
BA17	PB77A	4	PCLKT4_0	PB91A	4	PCLKT4_0
BA16	PB77B	4	PCLKC4_0	PB91B	4	PCLKC4_0
AR19	PB77C	4	VREF2_4	PB91C	4	VREF2_4
AR18	PB77D	4		PB91D	4	
AY17	PB79A	4	PCLKT4_5	PB93A	4	PCLKT4_5
AY16	PB79B	4	PCLKC4_5	PB93B	4	PCLKC4_5
AN18	PB79C	4		PB93C	4	
AP18	PB79D	4		PB93D	4	
AW17	PB80A	4	PCLKT4_3	PB94A	4	PCLKT4_3
AW16	PB80B	4	PCLKC4_3	PB94B	4	PCLKC4_3
AU17	PB80C	4	PCLKT4_4	PB94C	4	PCLKT4_4
AU16	PB80D	4	PCLKC4_4	PB94D	4	PCLKC4_4
AV17	PB81A	4		PB95A	4	
AV16	PB81B	4		PB95B	4	
AL18	PB81C	4		PB95C	4	
AM18	PB81D	4		PB95D	4	
BB15	PB83A	4		PB97A	4	
BB14	PB83B	4		PB97B	4	
AP17	PB83C	4		PB97C	4	
AN17	PB83D	4		PB97D	4	
BA15	PB84A	4		PB98A	4	
BA14	PB84B	4		PB98B	4	
AT16	PB84C	4		PB98C	4	
AT15	PB84D	4		PB98D	4	
AV15	PB85A	4		PB99A	4	
AV14	PB85B	4		PB99B	4	
AR16	PB85C	4		PB99C	4	
AR15	PB85D	4		PB99D	4	
AY14	PB87A	4		PB101A	4	
AY13	PB87B	4		PB101B	4	
AU15	PB87C	4		PB101C	4	
AU14	PB87D	4		PB101D	4	
BB13	PB88A	4		PB102A	4	

LFSC/M80, LFSC/M115 Logic Signal Connections: 1704 fcBGA^{1,2} (Cont.)

Ball Number	LFSC/M80			LFSC/M115		
	Ball Function	VCCIO Bank	Dual Function	Ball Function	VCCIO Bank	Dual Function
BB12	PB88B	4		PB102B	4	
AM17	PB88C	4		PB102C	4	
AL17	PB88D	4		PB102D	4	
AW14	PB89A	4		PB103A	4	
AW13	PB89B	4		PB103B	4	
AP16	PB89C	4		PB103C	4	
AN16	PB89D	4		PB103D	4	
BA13	PB91A	4		PB105A	4	
BA12	PB91B	4		PB105B	4	
AU13	PB91C	4		PB105C	4	
AU12	PB91D	4		PB105D	4	
BB11	PB92A	4		PB106A	4	
BB10	PB92B	4		PB106B	4	
AP15	PB92C	4		PB106C	4	
AN15	PB92D	4		PB106D	4	
AV13	PB93A	4		PB107A	4	
AV12	PB93B	4		PB107B	4	
AT13	PB93C	4		PB107C	4	
AT12	PB93D	4		PB107D	4	
BA11	PB95A	4		PB109A	4	
BA10	PB95B	4		PB109B	4	
AR13	PB95C	4		PB109C	4	
AR12	PB95D	4		PB109D	4	
AY11	PB96A	4		PB110A	4	
AY10	PB96B	4		PB110B	4	
AP14	PB96C	4		PB110C	4	
AN14	PB96D	4		PB110D	4	
BB9	PB97A	4		PB111A	4	
BB8	PB97B	4		PB111B	4	
AU11	PB97C	4		PB111C	4	
AU10	PB97D	4		PB111D	4	
AW11	PB99A	4		PB113A	4	
AW10	PB99B	4		PB113B	4	
AJ16	PB99C	4		PB113C	4	
AJ17	PB99D	4		PB113D	4	
BA9	PB100A	4		PB114A	4	
BA8	PB100B	4		PB114B	4	
AM15	PB100C	4		PB114C	4	
AL15	PB100D	4		PB114D	4	
AV11	PB101A	4		PB115A	4	
AV10	PB101B	4		PB115B	4	
AP13	PB101C	4		PB115C	4	
AP12	PB101D	4		PB115D	4	
BB7	PB103A	4		PB117A	4	
BB6	PB103B	4		PB117B	4	

LFSC/M80, LFSC/M115 Logic Signal Connections: 1704 fcBGA^{1,2} (Cont.)

Ball Number	LFSC/M80			LFSC/M115		
	Ball Function	VCCIO Bank	Dual Function	Ball Function	VCCIO Bank	Dual Function
AU9	PB103C	4		PB117C	4	
AU8	PB103D	4		PB117D	4	
AY8	PB104A	4		PB118A	4	
AY7	PB104B	4		PB118B	4	
AU7	PB104C	4		PB118C	4	
AU6	PB104D	4		PB118D	4	
BA7	PB105A	4		PB119A	4	
BA6	PB105B	4		PB119B	4	
AN13	PB105C	4		PB119C	4	
AN12	PB105D	4		PB119D	4	
AV9	PB107A	4		PB121A	4	
AV8	PB107B	4		PB121B	4	
AT10	PB107C	4		PB121C	4	
AT9	PB107D	4		PB121D	4	
AW8	PB108A	4		PB122A	4	
AW7	PB108B	4		PB122B	4	
AP11	PB108C	4		PB122C	4	
AP10	PB108D	4		PB122D	4	
BB5	PB109A	4		PB123A	4	
BB4	PB109B	4		PB123B	4	
AR10	PB109C	4		PB123C	4	
AR9	PB109D	4		PB123D	4	
BA5	PB111A	4		PB125A	4	
BA4	PB111B	4		PB125B	4	
AT7	PB111C	4		PB125C	4	
AT6	PB111D	4		PB125D	4	
BB3	PB112A	4		PB126A	4	
BA3	PB112B	4		PB126B	4	
AM14	PB112C	4		PB126C	4	
AL14	PB112D	4		PB126D	4	
AY5	PB113A	4		PB127A	4	
AY4	PB113B	4		PB127B	4	
AN11	PB113C	4		PB127C	4	
AN10	PB113D	4		PB127D	4	
AV7	PB115A	4		PB129A	4	
AV6	PB115B	4		PB129B	4	
AM12	PB115C	4		PB129C	4	
AM11	PB115D	4		PB129D	4	
AW5	PB116A	4		PB130A	4	
AW4	PB116B	4		PB130B	4	
AT5	PB116C	4		PB130C	4	
AT4	PB116D	4		PB130D	4	
AY2	PB117A	4		PB131A	4	
BA2	PB117B	4		PB131B	4	
AP9	PB117C	4		PB131C	4	

LFSC/M80, LFSC/M115 Logic Signal Connections: 1704 fcBGA^{1,2} (Cont.)

Ball Number	LFSC/M80			LFSC/M115		
	Ball Function	VCCIO Bank	Dual Function	Ball Function	VCCIO Bank	Dual Function
AP8	PB117D	4		PB131D	4	
AY3	PB119A	4		PB133A	4	
AW3	PB119B	4		PB133B	4	
AR6	PB119C	4		PB133C	4	
AR5	PB119D	4		PB133D	4	
AU5	PB120A	4		PB134A	4	
AV5	PB120B	4		PB134B	4	
AL12	PB120C	4		PB134C	4	
AL11	PB120D	4		PB134D	4	
AV3	PB121A	4		PB135A	4	
AV4	PB121B	4		PB135B	4	
AN9	PB121C	4		PB135C	4	
AN8	PB121D	4		PB135D	4	
AW1	PB123A	4		PB138A	4	
AY1	PB123B	4		PB138B	4	
AK14	PB123C	4	VREF1_4	PB138C	4	VREF1_4
AK13	PB123D	4		PB138D	4	
AV2	PB124A	4	LRC_DLLT_IN_C/LRC_DLLT_FB_D	PB139A	4	LRC_DLLT_IN_C/LRC_DLLT_FB_D
AW2	PB124B	4	LRC_DLLC_IN_C/LRC_DLLC_FB_D	PB139B	4	LRC_DLLC_IN_C/LRC_DLLC_FB_D
AM10	PB124C	4		PB139C	4	
AM9	PB124D	4		PB139D	4	
AV1	PB125A	4	LRC_PLLT_IN_A/LRC_PLLT_FB_B	PB141A	4	LRC_PLLT_IN_A/LRC_PLLT_FB_B
AU1	PB125B	4	LRC_PLLC_IN_A/LRC_PLLC_FB_B	PB141B	4	LRC_PLLC_IN_A/LRC_PLLC_FB_B
AL10	PB125C	4	LRC_DLLT_IN_D/LRC_DLLT_FB_C	PB141C	4	LRC_DLLT_IN_D/LRC_DLLT_FB_C
AL9	PB125D	4	LRC_DLLC_IN_D/LRC_DLLC_FB_C	PB141D	4	LRC_DLLC_IN_D/LRC_DLLC_FB_C
AT3	PROBE_VCC	-		PROBE_VCC	-	
AU2	PROBE_GND	-		PROBE_GND	-	
AP7	PR95D	3	LRC_PLLC_IN_B/LRC_PLLC_FB_A	PR117D	3	LRC_PLLC_IN_B/LRC_PLLC_FB_A
AN7	PR95C	3	LRC_PLLT_IN_B/LRC_PLLT_FB_A	PR117C	3	LRC_PLLT_IN_B/LRC_PLLT_FB_A
AR3	PR95B	3	LRC_DLLC_IN_F/LRC_DLLC_FB_E	PR117B	3	LRC_DLLC_IN_F/LRC_DLLC_FB_E
AR4	PR95A	3	LRC_DLLT_IN_F/LRC_DLLT_FB_E	PR117A	3	LRC_DLLT_IN_F/LRC_DLLT_FB_E
AP6	PR94D	3		PR116D	3	
AN6	PR94C	3		PR116C	3	
AT2	PR94B	3		PR116B	3	
AR2	PR94A	3		PR116A	3	
AM6	PR93D	3	LRC_DLLC_IN_E/LRC_DLLC_FB_F	PR115D	3	LRC_DLLC_IN_E/LRC_DLLC_FB_F
AL6	PR93C	3	LRC_DLLT_IN_E/LRC_DLLT_FB_F	PR115C	3	LRC_DLLT_IN_E/LRC_DLLT_FB_F
AP5	PR93B	3		PR115B	3	
AN5	PR93A	3		PR115A	3	
AL8	PR91D	3		PR112D	3	
AK8	PR91C	3		PR112C	3	
AP2	PR91B	3		PR112B	3	
AN2	PR91A	3		PR112A	3	
AJ12	PR90D	3		PR109D	3	
AH12	PR90C	3		PR109C	3	

LFSC/M80, LFSC/M115 Logic Signal Connections: 1704 fcBGA^{1,2} (Cont.)

Ball Number	LFSC/M80			LFSC/M115		
	Ball Function	VCCIO Bank	Dual Function	Ball Function	VCCIO Bank	Dual Function
AP1	PR90B	3		PR109B	3	
AN1	PR90A	3		PR109A	3	
AK10	PR89D	3	VREF2_3	PR107D	3	VREF2_3
AJ10	PR89C	3		PR107C	3	
AM5	PR89B	3		PR107B	3	
AL5	PR89A	3		PR107A	3	
AL7	PR86D	3		PR104D	3	
AK7	PR86C	3		PR104C	3	
AM1	PR86B	3		PR104B	3	
AL1	PR86A	3		PR104A	3	
AJ11	PR85D	3		PR103D	3	
AH11	PR85C	3		PR103C	3	
AK5	PR85B	3		PR103B	3	
AJ5	PR85A	3		PR103A	3	
AK9	PR84D	3		PR99D	3	
AJ9	PR84C	3		PR99C	3	
AK3	PR84B	3		PR99B	3	
AJ3	PR84A	3		PR99A	3	
AK6	PR82D	3		PR98D	3	
AJ6	PR82C	3		PR98C	3	
AK2	PR82B	3		PR98B	3	
AJ2	PR82A	3		PR98A	3	
AH10	PR81D	3		PR96D	3	
AG10	PR81C	3		PR96C	3	
AK1	PR81B	3		PR96B	3	
AJ1	PR81A	3		PR96A	3	
AH9	PR80D	3		PR94D	3	
AG9	PR80C	3		PR94C	3	
AH2	PR80B	3		PR94B	3	
AG2	PR80A	3		PR94A	3	
AH8	PR78D	3		PR92D	3	
AG8	PR78C	3		PR92C	3	
AG1	PR78B	3		PR92B	3	
AH1	PR78A	3		PR92A	3	
AG14	PR77D	3		PR91D	3	
AF14	PR77C	3		PR91C	3	
AG4	PR77B	3		PR91B	3	
AF4	PR77A	3		PR91A	3	
AH7	PR76D	3	DIFFR_3	PR90D	3	DIFFR_3
AG7	PR76C	3		PR90C	3	
AG3	PR76B	3		PR90B	3	
AF3	PR76A	3		PR90A	3	
AH6	PR74D	3		PR88D	3	
AG6	PR74C	3		PR88C	3	
AF1	PR74B	3		PR88B	3	

LFSC/M80, LFSC/M115 Logic Signal Connections: 1704 fcBGA^{1,2} (Cont.)

Ball Number	LFSC/M80			LFSC/M115		
	Ball Function	VCCIO Bank	Dual Function	Ball Function	VCCIO Bank	Dual Function
AE1	PR74A	3		PR88A	3	
AF12	PR73D	3		PR87D	3	
AE12	PR73C	3		PR87C	3	
AF2	PR73B	3		PR87B	3	
AE2	PR73A	3		PR87A	3	
AF11	PR72D	3		PR86D	3	
AE11	PR72C	3		PR86C	3	
AF5	PR72B	3		PR86B	3	
AE5	PR72A	3		PR86A	3	
AF10	PR69D	3		PR83D	3	
AE10	PR69C	3		PR83C	3	
AD1	PR69B	3		PR83B	3	
AC1	PR69A	3		PR83A	3	
AF9	PR68D	3		PR82D	3	
AE9	PR68C	3		PR82C	3	
AD2	PR68B	3		PR82B	3	
AC2	PR68A	3		PR82A	3	
AF6	PR67D	3		PR81D	3	
AE6	PR67C	3		PR81C	3	
AD3	PR67B	3		PR81B	3	
AC3	PR67A	3		PR81A	3	
AE8	PR65D	3		PR79D	3	
AD8	PR65C	3		PR79C	3	
AD4	PR65B	3		PR79B	3	
AC4	PR65A	3		PR79A	3	
AE7	PR64D	3		PR78D	3	
AD7	PR64C	3		PR78C	3	
AD5	PR64B	3		PR78B	3	
AC5	PR64A	3		PR78A	3	
AD6	PR63D	3		PR77D	3	
AC6	PR63C	3		PR77C	3	
AB1	PR63B	3		PR77B	3	
AA1	PR63A	3		PR77A	3	
AD9	PR61D	3		PR75D	3	
AC9	PR61C	3		PR75C	3	
AB2	PR61B	3		PR75B	3	
AA2	PR61A	3		PR75A	3	
AD14	PR60D	3		PR74D	3	
AC14	PR60C	3		PR74C	3	
AB5	PR60B	3		PR74B	3	
AA5	PR60A	3		PR74A	3	
AD10	PR59D	3		PR73D	3	
AC10	PR59C	3		PR73C	3	
Y1	PR59B	3		PR73B	3	
W1	PR59A	3		PR73A	3	

LFSC/M80, LFSC/M115 Logic Signal Connections: 1704 fcBGA^{1,2} (Cont.)

Ball Number	LFSC/M80			LFSC/M115		
	Ball Function	VCCIO Bank	Dual Function	Ball Function	VCCIO Bank	Dual Function
AB6	PR57D	3		PR71D	3	
AA6	PR57C	3		PR71C	3	
Y2	PR57B	3		PR71B	3	
W2	PR57A	3		PR71A	3	
AB7	PR56D	3		PR70D	3	
AA7	PR56C	3		PR70C	3	
Y3	PR56B	3		PR70B	3	
W3	PR56A	3		PR70A	3	
AC11	PR55D	3		PR69D	3	
AB11	PR55C	3	VREF1_3	PR69C	3	VREF1_3
Y4	PR55B	3		PR69B	3	
W4	PR55A	3		PR69A	3	
AB8	PR52D	3	PCLKC3_2	PR66D	3	PCLKC3_2
AA8	PR52C	3	PCLKT3_2	PR66C	3	PCLKT3_2
Y5	PR52B	3		PR66B	3	
W5	PR52A	3		PR66A	3	
AC12	PR51D	3	PCLKC3_3	PR65D	3	PCLKC3_3
AB12	PR51C	3	PCLKT3_3	PR65C	3	PCLKT3_3
V1	PR51B	3		PR65B	3	
U1	PR51A	3		PR65A	3	
W7	PR50D	3	PCLKC3_1	PR64D	3	PCLKC3_1
V7	PR50C	3	PCLKT3_1	PR64C	3	PCLKT3_1
V2	PR50B	3	PCLKC3_0	PR64B	3	PCLKC3_0
U2	PR50A	3	PCLKT3_0	PR64A	3	PCLKT3_0
AB9	PR48D	2	PCLKC2_2	PR62D	2	PCLKC2_2
AA9	PR48C	2	PCLKT2_2	PR62C	2	PCLKT2_2
T1	PR48B	2	PCLKC2_0	PR62B	2	PCLKC2_0
R1	PR48A	2	PCLKT2_0	PR62A	2	PCLKT2_0
AB10	PR47D	2	PCLKC2_3	PR61D	2	PCLKC2_3
AA10	PR47C	2	PCLKT2_3	PR61C	2	PCLKT2_3
U3	PR47B	2	PCLKC2_1	PR61B	2	PCLKC2_1
T3	PR47A	2	PCLKT2_1	PR61A	2	PCLKT2_1
Y9	PR46D	2		PR60D	2	
W9	PR46C	2		PR60C	2	
V5	PR46B	2		PR60B	2	
U5	PR46A	2		PR60A	2	
AA11	PR43D	2		PR57D	2	
Y11	PR43C	2		PR57C	2	
Y6	PR43B	2		PR57B	2	
W6	PR43A	2		PR57A	2	
Y10	PR42D	2		PR56D	2	
W10	PR42C	2		PR56C	2	
T2	PR42B	2		PR56B	2	
R2	PR42A	2		PR56A	2	
W8	PR41D	2		PR55D	2	

LFSC/M80, LFSC/M115 Logic Signal Connections: 1704 fcBGA^{1,2} (Cont.)

Ball Number	LFSC/M80			LFSC/M115		
	Ball Function	VCCIO Bank	Dual Function	Ball Function	VCCIO Bank	Dual Function
V8	PR41C	2		PR55C	2	
T4	PR41B	2		PR55B	2	
U4	PR41A	2		PR55A	2	
V9	PR39D	2		PR53D	2	
U9	PR39C	2		PR53C	2	
V6	PR39B	2		PR53B	2	
U6	PR39A	2		PR53A	2	
AA12	PR38D	2		PR52D	2	
Y12	PR38C	2		PR52C	2	
P1	PR38B	2		PR52B	2	
N1	PR38A	2		PR52A	2	
T7	PR37D	2		PR51D	2	
R7	PR37C	2		PR51C	2	
T5	PR37B	2		PR51B	2	
R5	PR37A	2		PR51A	2	
U10	PR35D	2		PR49D	2	
V10	PR35C	2		PR49C	2	
P2	PR35B	2		PR49B	2	
N2	PR35A	2		PR49A	2	
T8	PR34D	2		PR48D	2	
R8	PR34C	2		PR48C	2	
N3	PR34B	2		PR48B	2	
P3	PR34A	2		PR48A	2	
M6	PR33D	2		PR47D	2	
M7	PR33C	2		PR47C	2	
T6	PR33B	2		PR47B	2	
R6	PR33A	2		PR47A	2	
V11	PR31D	2		PR45D	2	
U11	PR31C	2		PR45C	2	
M1	PR31B	2		PR45B	2	
L1	PR31A	2		PR45A	2	
Y14	PR30D	2		PR44D	2	
W14	PR30C	2		PR44C	2	
M2	PR30B	2		PR44B	2	
L2	PR30A	2		PR44A	2	
T9	PR29D	2	DIFFR_2	PR43D	2	DIFFR_2
R9	PR29C	2	VREF1_2	PR43C	2	VREF1_2
P4	PR29B	2		PR43B	2	
N4	PR29A	2		PR43A	2	
N7	PR26D	2		PR40D	2	
N8	PR26C	2		PR40C	2	
P5	PR26B	2		PR40B	2	
N5	PR26A	2		PR40A	2	
K7	PR25D	2		PR38D	2	
J7	PR25C	2		PR38C	2	

LFSC/M80, LFSC/M115 Logic Signal Connections: 1704 fcBGA^{1,2} (Cont.)

Ball Number	LFSC/M80			LFSC/M115		
	Ball Function	VCCIO Bank	Dual Function	Ball Function	VCCIO Bank	Dual Function
J1	PR25B	2		PR38B	2	
K1	PR25A	2		PR38A	2	
V12	PR24D	2		PR34D	2	
U12	PR24C	2		PR34C	2	
K2	PR24B	2		PR34B	2	
J2	PR24A	2		PR34A	2	
R10	PR22D	2		PR30D	2	
T10	PR22C	2		PR30C	2	
L5	PR22B	2		PR30B	2	
K5	PR22A	2		PR30A	2	
P9	PR21D	2		PR26D	2	
N9	PR21C	2		PR26C	2	
L6	PR21B	2		PR26B	2	
K6	PR21A	2		PR26A	2	
M8	PR20D	2		PR19D	2	
M9	PR20C	2		PR19C	2	
H1	PR20B	2		PR19B	2	
G1	PR20A	2		PR19A	2	
U14	PR18D	2	VREF2_2	PR18D	2	VREF2_2
T14	PR18C	2		PR18C	2	
H2	PR18B	2	URC_DLLC_IN_D/URC_DLLC_FB_C	PR18B	2	URC_DLLC_IN_D/URC_DLLC_FB_C
G2	PR18A	2	URC_DLLT_IN_D/URC_DLLT_FB_C	PR18A	2	URC_DLLT_IN_D/URC_DLLT_FB_C
P10	PR17D	2	URC_PLLC_IN_B/URC_PLLC_FB_A	PR17D	2	URC_PLLC_IN_B/URC_PLLC_FB_A
N10	PR17C	2	URC_PLLT_IN_B/URC_PLLT_FB_A	PR17C	2	URC_PLLT_IN_B/URC_PLLT_FB_A
H3	PR17B	2	URC_DLLC_IN_C/URC_DLLC_FB_D	PR17B	2	URC_DLLC_IN_C/URC_DLLC_FB_D
G3	PR17A	2	URC_DLLT_IN_C/URC_DLLT_FB_D	PR17A	2	URC_DLLT_IN_C/URC_DLLT_FB_D
R11	PR16D	2		PR15D	2	
P11	PR16C	2		PR15C	2	
J5	PR16B	2	URC_PLLC_IN_A/URC_PLLC_FB_B	PR15B	2	URC_PLLC_IN_A/URC_PLLC_FB_B
J6	PR16A	2	URC_PLLT_IN_A/URC_PLLT_FB_B	PR15A	2	URC_PLLT_IN_A/URC_PLLT_FB_B
P18	VCCJ	-		VCCJ	-	
P19	TDO	-	TDO	TDO	-	TDO
R21	TMS	-		TMS	-	
P20	TCK	-		TCK	-	
P12	TDI	-		TDI	-	
P17	PROGRAMN	1		PROGRAMN	1	
P21	MPIIRQN	1	CFGIRQN/MPI_IRQ_N	MPIIRQN	1	CFGIRQN/MPI_IRQ_N
P13	CCLK	1		CCLK	1	
H10	RESP_URC	-		RESP_URC	-	
N13	VCC12	-		VCC12	-	
H9	A_REFCLKN_R	-		A_REFCLKN_R	-	
G9	A_REFCLKP_R	-		A_REFCLKP_R	-	
F2	VCC12	-		VCC12	-	
H4	A_VDDIB0_R	-		A_VDDIB0_R	-	
C1	A_HDINP0_R	-	PCS 3E0 CH 0 IN P	A_HDINP0_R	-	PCS 3E0 CH 0 IN P

LFSC/M80, LFSC/M115 Logic Signal Connections: 1704 fcBGA^{1,2} (Cont.)

Ball Number	LFSC/M80			LFSC/M115		
	Ball Function	VCCIO Bank	Dual Function	Ball Function	VCCIO Bank	Dual Function
D1	A_HDINN0_R	-	PCS 3E0 CH 0 IN N	A_HDINN0_R	-	PCS 3E0 CH 0 IN N
F1	VCC12	-		VCC12	-	
A3	A_HDOUTP0_R	-	PCS 3E0 CH 0 OUT P	A_HDOUTP0_R	-	PCS 3E0 CH 0 OUT P
E1	A_VDDOB0_R	-		A_VDDOB0_R	-	
B3	A_HDOUTN0_R	-	PCS 3E0 CH 0 OUT N	A_HDOUTN0_R	-	PCS 3E0 CH 0 OUT N
C2	A_VDDOB1_R	-		A_VDDOB1_R	-	
A4	A_HDOUTN1_R	-	PCS 3E0 CH 1 OUT N	A_HDOUTN1_R	-	PCS 3E0 CH 1 OUT N
B2	VCC12	-		VCC12	-	
B4	A_HDOUTP1_R	-	PCS 3E0 CH 1 OUT P	A_HDOUTP1_R	-	PCS 3E0 CH 1 OUT P
E3	A_HDINN1_R	-	PCS 3E0 CH 1 IN N	A_HDINN1_R	-	PCS 3E0 CH 1 IN N
D3	A_HDINP1_R	-	PCS 3E0 CH 1 IN P	A_HDINP1_R	-	PCS 3E0 CH 1 IN P
M10	VCC12	-		VCC12	-	
E2	A_VDDIB1_R	-		A_VDDIB1_R	-	
J11	VCC12	-		VCC12	-	
M11	A_VDDIB2_R	-		A_VDDIB2_R	-	
D4	A_HDINP2_R	-	PCS 3E0 CH 2 IN P	A_HDINP2_R	-	PCS 3E0 CH 2 IN P
E4	A_HDINN2_R	-	PCS 3E0 CH 2 IN N	A_HDINN2_R	-	PCS 3E0 CH 2 IN N
K9	VCC12	-		VCC12	-	
A5	A_HDOUTP2_R	-	PCS 3E0 CH 2 OUT P	A_HDOUTP2_R	-	PCS 3E0 CH 2 OUT P
D2	A_VDDOB2_R	-		A_VDDOB2_R	-	
B5	A_HDOUTN2_R	-	PCS 3E0 CH 2 OUT N	A_HDOUTN2_R	-	PCS 3E0 CH 2 OUT N
L10	A_VDDOB3_R	-		A_VDDOB3_R	-	
B6	A_HDOUTN3_R	-	PCS 3E0 CH 3 OUT N	A_HDOUTN3_R	-	PCS 3E0 CH 3 OUT N
G6	VCC12	-		VCC12	-	
A6	A_HDOUTP3_R	-	PCS 3E0 CH 3 OUT P	A_HDOUTP3_R	-	PCS 3E0 CH 3 OUT P
E5	A_HDINN3_R	-	PCS 3E0 CH 3 IN N	A_HDINN3_R	-	PCS 3E0 CH 3 IN N
D5	A_HDINP3_R	-	PCS 3E0 CH 3 IN P	A_HDINP3_R	-	PCS 3E0 CH 3 IN P
K12	VCC12	-		VCC12	-	
L13	A_VDDIB3_R	-		A_VDDIB3_R	-	
N14	VCC12	-		VCC12	-	
F9	B_VDDIB0_R	-		B_VDDIB0_R	-	
D6	B_HDINP0_R	-	PCS 3E1 CH 0 IN P	B_HDINP0_R	-	PCS 3E1 CH 0 IN P
E6	B_HDINN0_R	-	PCS 3E1 CH 0 IN N	B_HDINN0_R	-	PCS 3E1 CH 0 IN N
J8	VCC12	-		VCC12	-	
B7	B_HDOUTP0_R	-	PCS 3E1 CH 0 OUT P	B_HDOUTP0_R	-	PCS 3E1 CH 0 OUT P
G4	B_VDDOB0_R	-		B_VDDOB0_R	-	
A7	B_HDOUTN0_R	-	PCS 3E1 CH 0 OUT N	B_HDOUTN0_R	-	PCS 3E1 CH 0 OUT N
K8	B_VDDOB1_R	-		B_VDDOB1_R	-	
A8	B_HDOUTN1_R	-	PCS 3E1 CH 1 OUT N	B_HDOUTN1_R	-	PCS 3E1 CH 1 OUT N
L9	VCC12	-		VCC12	-	
B8	B_HDOUTP1_R	-	PCS 3E1 CH 1 OUT P	B_HDOUTP1_R	-	PCS 3E1 CH 1 OUT P
E7	B_HDINN1_R	-	PCS 3E1 CH 1 IN N	B_HDINN1_R	-	PCS 3E1 CH 1 IN N
D7	B_HDINP1_R	-	PCS 3E1 CH 1 IN P	B_HDINP1_R	-	PCS 3E1 CH 1 IN P
F10	VCC12	-		VCC12	-	
K13	B_VDDIB1_R	-		B_VDDIB1_R	-	

LFSC/M80, LFSC/M115 Logic Signal Connections: 1704 fcBGA^{1,2} (Cont.)

Ball Number	LFSC/M80			LFSC/M115		
	Ball Function	VCCIO Bank	Dual Function	Ball Function	VCCIO Bank	Dual Function
K14	VCC12	-		VCC12	-	
H11	B_VDDIB2_R	-		B_VDDIB2_R	-	
D8	B_HDINP2_R	-	PCS 3E1 CH 2 IN P	B_HDINP2_R	-	PCS 3E1 CH 2 IN P
E8	B_HDINN2_R	-	PCS 3E1 CH 2 IN N	B_HDINN2_R	-	PCS 3E1 CH 2 IN N
G5	VCC12	-		VCC12	-	
B9	B_HDOUDP2_R	-	PCS 3E1 CH 2 OUT P	B_HDOUDP2_R	-	PCS 3E1 CH 2 OUT P
L12	B_VDDOB2_R	-		B_VDDOB2_R	-	
A9	B_HDOU2N2_R	-	PCS 3E1 CH 2 OUT N	B_HDOU2N2_R	-	PCS 3E1 CH 2 OUT N
C5	B_VDDOB3_R	-		B_VDDOB3_R	-	
A10	B_HDOU2N3_R	-	PCS 3E1 CH 3 OUT N	B_HDOU2N3_R	-	PCS 3E1 CH 3 OUT N
H5	VCC12	-		VCC12	-	
B10	B_HDOU2P3_R	-	PCS 3E1 CH 3 OUT P	B_HDOU2P3_R	-	PCS 3E1 CH 3 OUT P
E9	B_HDINN3_R	-	PCS 3E1 CH 3 IN N	B_HDINN3_R	-	PCS 3E1 CH 3 IN N
D9	B_HDINP3_R	-	PCS 3E1 CH 3 IN P	B_HDINP3_R	-	PCS 3E1 CH 3 IN P
J13	VCC12	-		VCC12	-	
H12	B_VDDIB3_R	-		B_VDDIB3_R	-	
J12	VCC12	-		VCC12	-	
M14	B_REFCLKN_R	-		B_REFCLKN_R	-	
L14	B_REFCLKP_R	-		B_REFCLKP_R	-	
J14	VCC12	-		VCC12	-	
G12	C_VDDIB0_R	-		C_VDDIB0_R	-	
D10	C_HDINP0_R	-	PCS 3E2 CH 0 IN P	C_HDINP0_R	-	PCS 3E2 CH 0 IN P
E10	C_HDINN0_R	-	PCS 3E2 CH 0 IN N	C_HDINN0_R	-	PCS 3E2 CH 0 IN N
H6	VCC12	-		VCC12	-	
B11	C_HDOU2P0_R	-	PCS 3E2 CH 0 OUT P	C_HDOU2P0_R	-	PCS 3E2 CH 0 OUT P
M12	C_VDDOB0_R	-		C_VDDOB0_R	-	
A11	C_HDOU2N0_R	-	PCS 3E2 CH 0 OUT N	C_HDOU2N0_R	-	PCS 3E2 CH 0 OUT N
L11	C_VDDOB1_R	-		C_VDDOB1_R	-	
A12	C_HDOU2N1_R	-	PCS 3E2 CH 1 OUT N	C_HDOU2N1_R	-	PCS 3E2 CH 1 OUT N
K11	VCC12	-		VCC12	-	
B12	C_HDOU2P1_R	-	PCS 3E2 CH 1 OUT P	C_HDOU2P1_R	-	PCS 3E2 CH 1 OUT P
E11	C_HDINN1_R	-	PCS 3E2 CH 1 IN N	C_HDINN1_R	-	PCS 3E2 CH 1 IN N
D11	C_HDINP1_R	-	PCS 3E2 CH 1 IN P	C_HDINP1_R	-	PCS 3E2 CH 1 IN P
H13	VCC12	-		VCC12	-	
C6	C_VDDIB1_R	-		C_VDDIB1_R	-	
H15	VCC12	-		VCC12	-	
G13	C_VDDIB2_R	-		C_VDDIB2_R	-	
D12	C_HDINP2_R	-	PCS 3E2 CH 2 IN P	C_HDINP2_R	-	PCS 3E2 CH 2 IN P
E12	C_HDINN2_R	-	PCS 3E2 CH 2 IN N	C_HDINN2_R	-	PCS 3E2 CH 2 IN N
J9	VCC12	-		VCC12	-	
B13	C_HDOU2P2_R	-	PCS 3E2 CH 2 OUT P	C_HDOU2P2_R	-	PCS 3E2 CH 2 OUT P
K10	C_VDDOB2_R	-		C_VDDOB2_R	-	
A13	C_HDOU2N2_R	-	PCS 3E2 CH 2 OUT N	C_HDOU2N2_R	-	PCS 3E2 CH 2 OUT N
J10	C_VDDOB3_R	-		C_VDDOB3_R	-	
A14	C_HDOU2N3_R	-	PCS 3E2 CH 3 OUT N	C_HDOU2N3_R	-	PCS 3E2 CH 3 OUT N

LFSC/M80, LFSC/M115 Logic Signal Connections: 1704 fcBGA^{1,2} (Cont.)

Ball Number	LFSC/M80			LFSC/M115		
	Ball Function	VCCIO Bank	Dual Function	Ball Function	VCCIO Bank	Dual Function
F5	VCC12	-		VCC12	-	
B14	C_HDOUTP3_R	-	PCS 3E2 CH 3 OUT P	C_HDOUTP3_R	-	PCS 3E2 CH 3 OUT P
E13	C_HDINN3_R	-	PCS 3E2 CH 3 IN N	C_HDINN3_R	-	PCS 3E2 CH 3 IN N
D13	C_HDINP3_R	-	PCS 3E2 CH 3 IN P	C_HDINP3_R	-	PCS 3E2 CH 3 IN P
F12	VCC12	-		VCC12	-	
G14	C_VDDIB3_R	-		C_VDDIB3_R	-	
F11	VCC12	-		VCC12	-	
K15	C_REFCLKN_R	-		C_REFCLKN_R	-	
J15	C_REFCLKP_R	-		C_REFCLKP_R	-	
G15	VCC12	-		VCC12	-	
H16	D_VDDIB0_R	-		D_VDDIB0_R	-	
D14	D_HDINP0_R	-	PCS 3E3 CH 0 IN P	D_HDINP0_R	-	PCS 3E3 CH 0 IN P
E14	D_HDINN0_R	-	PCS 3E3 CH 0 IN N	D_HDINN0_R	-	PCS 3E3 CH 0 IN N
F6	VCC12	-		VCC12	-	
B15	D_HDOUTP0_R	-	PCS 3E3 CH 0 OUT P	D_HDOUTP0_R	-	PCS 3E3 CH 0 OUT P
M13	D_VDDOB0_R	-		D_VDDOB0_R	-	
A15	D_HDOUTN0_R	-	PCS 3E3 CH 0 OUT N	D_HDOUTN0_R	-	PCS 3E3 CH 0 OUT N
F8	D_VDDOB1_R	-		D_VDDOB1_R	-	
A16	D_HDOUTN1_R	-	PCS 3E3 CH 1 OUT N	D_HDOUTN1_R	-	PCS 3E3 CH 1 OUT N
F7	VCC12	-		VCC12	-	
B16	D_HDOUTP1_R	-	PCS 3E3 CH 1 OUT P	D_HDOUTP1_R	-	PCS 3E3 CH 1 OUT P
F15	D_HDINN1_R	-	PCS 3E3 CH 1 IN N	D_HDINN1_R	-	PCS 3E3 CH 1 IN N
E15	D_HDINP1_R	-	PCS 3E3 CH 1 IN P	D_HDINP1_R	-	PCS 3E3 CH 1 IN P
K17	VCC12	-		VCC12	-	
F13	D_VDDIB1_R	-		D_VDDIB1_R	-	
C14	VCC12	-		VCC12	-	
C15	D_VDDIB2_R	-		D_VDDIB2_R	-	
D16	D_HDINP2_R	-	PCS 3E3 CH 2 IN P	D_HDINP2_R	-	PCS 3E3 CH 2 IN P
E16	D_HDINN2_R	-	PCS 3E3 CH 2 IN N	D_HDINN2_R	-	PCS 3E3 CH 2 IN N
C11	VCC12	-		VCC12	-	
B17	D_HDOUTP2_R	-	PCS 3E3 CH 2 OUT P	D_HDOUTP2_R	-	PCS 3E3 CH 2 OUT P
C9	D_VDDOB2_R	-		D_VDDOB2_R	-	
A17	D_HDOUTN2_R	-	PCS 3E3 CH 2 OUT N	D_HDOUTN2_R	-	PCS 3E3 CH 2 OUT N
D17	D_VDDOB3_R	-		D_VDDOB3_R	-	
A18	D_HDOUTN3_R	-	PCS 3E3 CH 3 OUT N	D_HDOUTN3_R	-	PCS 3E3 CH 3 OUT N
C17	VCC12	-		VCC12	-	
B18	D_HDOUTP3_R	-	PCS 3E3 CH 3 OUT P	D_HDOUTP3_R	-	PCS 3E3 CH 3 OUT P
F17	D_HDINN3_R	-	PCS 3E3 CH 3 IN N	D_HDINN3_R	-	PCS 3E3 CH 3 IN N
E17	D_HDINP3_R	-	PCS 3E3 CH 3 IN P	D_HDINP3_R	-	PCS 3E3 CH 3 IN P
F14	VCC12	-		VCC12	-	
F16	D_VDDIB3_R	-		D_VDDIB3_R	-	
G16	VCC12	-		VCC12	-	
M17	D_REFCLKN_R	-		D_REFCLKN_R	-	
L17	D_REFCLKP_R	-		D_REFCLKP_R	-	
G18	PT77D	1	HDC/SI	PT93D	1	HDC/SI

LFSC/M80, LFSC/M115 Logic Signal Connections: 1704 fcBGA^{1,2} (Cont.)

Ball Number	LFSC/M80			LFSC/M115		
	Ball Function	VCCIO Bank	Dual Function	Ball Function	VCCIO Bank	Dual Function
H18	PT77C	1	LDCN/SCS	PT93C	1	LDCN/SCS
F18	PT77B	1	D8/MPI_DATA8	PT93B	1	D8/MPI_DATA8
E18	PT77A	1	CS1/MPI_CS1	PT93A	1	CS1/MPI_CS1
H19	PT75D	1	D9/MPI_DATA9	PT90D	1	D9/MPI_DATA9
G19	PT75C	1	D10/MPI_DATA10	PT90C	1	D10/MPI_DATA10
D19	PT75B	1	CS0N/MPI_CS0N	PT90B	1	CS0N/MPI_CS0N
D18	PT75A	1	RDN/MPI_STRB_N	PT90A	1	RDN/MPI_STRB_N
J20	PT74D	1	WRN/MPI_WR_N	PT89D	1	WRN/MPI_WR_N
K20	PT74C	1	D7/MPI_DATA7	PT89C	1	D7/MPI_DATA7
E19	PT74B	1	D6/MPI_DATA6	PT89B	1	D6/MPI_DATA6
F19	PT74A	1	D5/MPI_DATA5	PT89A	1	D5/MPI_DATA5
K18	PT73D	1	D4/MPI_DATA4	PT87D	1	D4/MPI_DATA4
J18	PT73C	1	D3/MPI_DATA3	PT87C	1	D3/MPI_DATA3
A19	PT73B	1	D2/MPI_DATA2	PT87B	1	D2/MPI_DATA2
B19	PT73A	1	D1/MPI_DATA1	PT87A	1	D1/MPI_DATA1
H17	PT71D	1	D16/PCLKC1_3/MPI_DATA16	PT86D	1	D16/PCLKC1_3/MPI_DATA16
J17	PT71C	1	D17/PCLKT1_3/MPI_DATA17	PT86C	1	D17/PCLKT1_3/MPI_DATA17
B20	PT71B	1	D0/MPI_DATA0	PT86B	1	D0/MPI_DATA0
C20	PT71A	1	QOUT/CEON	PT86A	1	QOUT/CEON
M20	PT70D	1	VREF2_1	PT83D	1	VREF2_1
L20	PT70C	1	D18/MPI_DATA18	PT83C	1	D18/MPI_DATA18
F20	PT70B	1	DOUT	PT83B	1	DOUT
G20	PT70A	1	MCA_DONE_IN	PT83A	1	MCA_DONE_IN
K19	PT69D	1	D19/PCLKC1_2/MPI_DATA19	PT81D	1	D19/PCLKC1_2/MPI_DATA19
J19	PT69C	1	D20/PCLKT1_2/MPI_DATA20	PT81C	1	D20/PCLKT1_2/MPI_DATA20
D20	PT69B	1	MCA_CLK_P1_OUT	PT81B	1	MCA_CLK_P1_OUT
E20	PT69A	1	MCA_CLK_P1_IN	PT81A	1	MCA_CLK_P1_IN
H21	PT67D	1	D21/PCLKC1_1/MPI_DATA21	PT78D	1	D21/PCLKC1_1/MPI_DATA21
G21	PT67C	1	D22/PCLKT1_1/MPI_DATA22	PT78C	1	D22/PCLKT1_1/MPI_DATA22
B21	PT67B	1	MCA_CLK_P2_OUT	PT78B	1	MCA_CLK_P2_OUT
C21	PT67A	1	MCA_CLK_P2_IN	PT78A	1	MCA_CLK_P2_IN
M21	PT66D	1	MCA_DONE_OUT	PT75D	1	MCA_DONE_OUT
L21	PT66C	1	BUSYN/RCLK/SCK	PT75C	1	BUSYN/RCLK/SCK
A21	PT66B	1	DP0/MPI_PAR0	PT75B	1	DP0/MPI_PAR0
A20	PT66A	1	MPI_TA	PT75A	1	MPI_TA
J21	PT65D	1	D23/MPI_DATA23	PT73D	1	D23/MPI_DATA23
K21	PT65C	1	DP2/MPI_PAR2	PT73C	1	DP2/MPI_PAR2
E21	PT65B	1	PCLKC1_0	PT73B	1	PCLKC1_0
F21	PT65A	1	PCLKT1_0/MPI_CLK	PT73A	1	PCLKT1_0/MPI_CLK
G22	PT63D	1	DP3/PCLKC1_4/MPI_PAR3	PT71D	1	DP3/PCLKC1_4/MPI_PAR3
H22	PT63C	1	D24/PCLKT1_4/MPI_DATA24	PT71C	1	D24/PCLKT1_4/MPI_DATA24
A23	PT63B	1	MPI_RETRY	PT71B	1	MPI_RETRY
A22	PT63A	1	A0/MPI_ADDR14	PT71A	1	A0/MPI_ADDR14
L22	PT61D	1	A1/MPI_ADDR15	PT69D	1	A1/MPI_ADDR15
M22	PT61C	1	A2/MPI_ADDR16	PT69C	1	A2/MPI_ADDR16

LFSC/M80, LFSC/M115 Logic Signal Connections: 1704 fcBGA^{1,2} (Cont.)

Ball Number	LFSC/M80			LFSC/M115		
	Ball Function	VCCIO Bank	Dual Function	Ball Function	VCCIO Bank	Dual Function
B22	PT61B	1	A3/MPI_ADDR17	PT69B	1	A3/MPI_ADDR17
B23	PT61A	1	A4/MPI_ADDR18	PT69A	1	A4/MPI_ADDR18
K23	PT60D	1	D25/PCLKC1_5/MPI_DATA25	PT66D	1	D25/PCLKC1_5/MPI_DATA25
J23	PT60C	1	D26/PCLKT1_5/MPI_DATA26	PT66C	1	D26/PCLKT1_5/MPI_DATA26
D22	PT60B	1	A5/MPI_ADDR19	PT66B	1	A5/MPI_ADDR19
E22	PT60A	1	A6/MPI_ADDR20	PT66A	1	A6/MPI_ADDR20
K22	PT59D	1	D27/MPI_DATA27	PT63D	1	D27/MPI_DATA27
J22	PT59C	1	VREF1_1	PT63C	1	VREF1_1
D23	PT59B	1	A7/MPI_ADDR21	PT63B	1	A7/MPI_ADDR21
C23	PT59A	1	A8/MPI_ADDR22	PT63A	1	A8/MPI_ADDR22
L23	PT57D	1	D28/PCLKC1_6/MPI_DATA28	PT61D	1	D28/PCLKC1_6/MPI_DATA28
M23	PT57C	1	D29/PCLKT1_6/MPI_DATA29	PT61C	1	D29/PCLKT1_6/MPI_DATA29
A24	PT57B	1	A9/MPI_ADDR23	PT61B	1	A9/MPI_ADDR23
B24	PT57A	1	A10/MPI_ADDR24	PT61A	1	A10/MPI_ADDR24
K25	PT56D	1	D30/PCLKC1_7/MPI_DATA30	PT58D	1	D30/PCLKC1_7/MPI_DATA30
J25	PT56C	1	D31/PCLKT1_7/MPI_DATA31	PT58C	1	D31/PCLKT1_7/MPI_DATA31
F23	PT56B	1	A11/MPI_ADDR25	PT58B	1	A11/MPI_ADDR25
F22	PT56A	1	A12/MPI_ADDR26	PT58A	1	A12/MPI_ADDR26
J26	PT55D	1	D11/MPI_DATA11	PT57D	1	D11/MPI_DATA11
K26	PT55C	1	D12/MPI_DATA12	PT57C	1	D12/MPI_DATA12
E23	PT55B	1	A13/MPI_ADDR27	PT57B	1	A13/MPI_ADDR27
E24	PT55A	1	A14/MPI_ADDR28	PT57A	1	A14/MPI_ADDR28
G23	PT53D	1	A16/MPI_ADDR30	PT55D	1	A16/MPI_ADDR30
G24	PT53C	1	D13/MPI_DATA13	PT55C	1	D13/MPI_DATA13
F26	PT53B	1	A15/MPI_ADDR29	PT55B	1	A15/MPI_ADDR29
F27	PT53A	1	A17/MPI_ADDR31	PT55A	1	A17/MPI_ADDR31
H25	PT52D	1	A19/MPI_TSI21	PT54D	1	A19/MPI_TSI21
H24	PT52C	1	A20/MPI_BDIP	PT54C	1	A20/MPI_BDIP
C25	PT52B	1	A18/MPI_TSI20	PT54B	1	A18/MPI_TSI20
C26	PT52A	1	MPI_TEA	PT54A	1	MPI_TEA
K24	PT51D	1	D14/MPI_DATA14	PT51D	1	D14/MPI_DATA14
J24	PT51C	1	DP1/MPI_PAR1	PT51C	1	DP1/MPI_PAR1
F24	PT51B	1	A21/MPI_BURST	PT51B	1	A21/MPI_BURST
F25	PT51A	1	D15/MPI_DATA15	PT51A	1	D15/MPI_DATA15
L26	D_REFCLKP_L	-		D_REFCLKP_L	-	
M26	D_REFCLKN_L	-		D_REFCLKN_L	-	
G27	VCC12	-		VCC12	-	
C29	D_VDDIB3_L	-		D_VDDIB3_L	-	
F28	VCC12	-		VCC12	-	
D26	D_HDINP3_L	-	PCS 363 CH 3 IN P	D_HDINP3_L	-	PCS 363 CH 3 IN P
E26	D_HDINN3_L	-	PCS 363 CH 3 IN N	D_HDINN3_L	-	PCS 363 CH 3 IN N
B25	D_HDOUTP3_L	-	PCS 363 CH 3 OUT P	D_HDOUTP3_L	-	PCS 363 CH 3 OUT P
D24	VCC12	-		VCC12	-	
A25	D_HDOUTN3_L	-	PCS 363 CH 3 OUT N	D_HDOUTN3_L	-	PCS 363 CH 3 OUT N
E25	D_VDDOB3_L	-		D_VDDOB3_L	-	

LFSC/M80, LFSC/M115 Logic Signal Connections: 1704 fcBGA^{1,2} (Cont.)

Ball Number	LFSC/M80			LFSC/M115		
	Ball Function	VCCIO Bank	Dual Function	Ball Function	VCCIO Bank	Dual Function
A26	D_HDOURN2_L	-	PCS 363 CH 2 OUT N	D_HDOURN2_L	-	PCS 363 CH 2 OUT N
C34	D_VDDOB2_L	-		D_VDDOB2_L	-	
B26	D_HDOURP2_L	-	PCS 363 CH 2 OUT P	D_HDOURP2_L	-	PCS 363 CH 2 OUT P
C32	VCC12	-		VCC12	-	
E27	D_HDINN2_L	-	PCS 363 CH 2 IN N	D_HDINN2_L	-	PCS 363 CH 2 IN N
D27	D_HDINP2_L	-	PCS 363 CH 2 IN P	D_HDINP2_L	-	PCS 363 CH 2 IN P
G25	D_VDDIB2_L	-		D_VDDIB2_L	-	
F29	VCC12	-		VCC12	-	
H26	D_VDDIB1_L	-		D_VDDIB1_L	-	
F30	VCC12	-		VCC12	-	
D28	D_HDINP1_L	-	PCS 363 CH 1 IN P	D_HDINP1_L	-	PCS 363 CH 1 IN P
E28	D_HDINN1_L	-	PCS 363 CH 1 IN N	D_HDINN1_L	-	PCS 363 CH 1 IN N
B27	D_HDOURP1_L	-	PCS 363 CH 1 OUT P	D_HDOURP1_L	-	PCS 363 CH 1 OUT P
F36	VCC12	-		VCC12	-	
A27	D_HDOURN1_L	-	PCS 363 CH 1 OUT N	D_HDOURN1_L	-	PCS 363 CH 1 OUT N
F35	D_VDDOB1_L	-		D_VDDOB1_L	-	
A28	D_HDOURN0_L	-	PCS 363 CH 0 OUT N	D_HDOURN0_L	-	PCS 363 CH 0 OUT N
M30	D_VDDOB0_L	-		D_VDDOB0_L	-	
B28	D_HDOURP0_L	-	PCS 363 CH 0 OUT P	D_HDOURP0_L	-	PCS 363 CH 0 OUT P
F37	VCC12	-		VCC12	-	
E29	D_HDINN0_L	-	PCS 363 CH 0 IN N	D_HDINN0_L	-	PCS 363 CH 0 IN N
D29	D_HDINP0_L	-	PCS 363 CH 0 IN P	D_HDINP0_L	-	PCS 363 CH 0 IN P
H27	D_VDDIB0_L	-		D_VDDIB0_L	-	
G28	VCC12	-		VCC12	-	
J28	C_REFCLKP_L	-		C_REFCLKP_L	-	
K28	C_REFCLKN_L	-		C_REFCLKN_L	-	
F32	VCC12	-		VCC12	-	
G29	C_VDDIB3_L	-		C_VDDIB3_L	-	
C31	VCC12	-		VCC12	-	
D30	C_HDINP3_L	-	PCS 362 CH 3 IN P	C_HDINP3_L	-	PCS 362 CH 3 IN P
E30	C_HDINN3_L	-	PCS 362 CH 3 IN N	C_HDINN3_L	-	PCS 362 CH 3 IN N
B29	C_HDOURP3_L	-	PCS 362 CH 3 OUT P	C_HDOURP3_L	-	PCS 362 CH 3 OUT P
F38	VCC12	-		VCC12	-	
A29	C_HDOURN3_L	-	PCS 362 CH 3 OUT N	C_HDOURN3_L	-	PCS 362 CH 3 OUT N
J33	C_VDDOB3_L	-		C_VDDOB3_L	-	
A30	C_HDOURN2_L	-	PCS 362 CH 2 OUT N	C_HDOURN2_L	-	PCS 362 CH 2 OUT N
K33	C_VDDOB2_L	-		C_VDDOB2_L	-	
B30	C_HDOURP2_L	-	PCS 362 CH 2 OUT P	C_HDOURP2_L	-	PCS 362 CH 2 OUT P
J34	VCC12	-		VCC12	-	
F31	C_HDINN2_L	-	PCS 362 CH 2 IN N	C_HDINN2_L	-	PCS 362 CH 2 IN N
E31	C_HDINP2_L	-	PCS 362 CH 2 IN P	C_HDINP2_L	-	PCS 362 CH 2 IN P
G30	C_VDDIB2_L	-		C_VDDIB2_L	-	
H28	VCC12	-		VCC12	-	
C37	C_VDDIB1_L	-		C_VDDIB1_L	-	
H30	VCC12	-		VCC12	-	

LFSC/M80, LFSC/M115 Logic Signal Connections: 1704 fcBGA^{1,2} (Cont.)

Ball Number	LFSC/M80			LFSC/M115		
	Ball Function	VCCIO Bank	Dual Function	Ball Function	VCCIO Bank	Dual Function
D32	C_HDINP1_L	-	PCS 362 CH 1 IN P	C_HDINP1_L	-	PCS 362 CH 1 IN P
E32	C_HDINN1_L	-	PCS 362 CH 1 IN N	C_HDINN1_L	-	PCS 362 CH 1 IN N
B31	C_HDOUTP1_L	-	PCS 362 CH 1 OUT P	C_HDOUTP1_L	-	PCS 362 CH 1 OUT P
K32	VCC12	-		VCC12	-	
A31	C_HDOUTN1_L	-	PCS 362 CH 1 OUT N	C_HDOUTN1_L	-	PCS 362 CH 1 OUT N
L32	C_VDDOB1_L	-		C_VDDOB1_L	-	
A32	C_HDOUTN0_L	-	PCS 362 CH 0 OUT N	C_HDOUTN0_L	-	PCS 362 CH 0 OUT N
M31	C_VDDOB0_L	-		C_VDDOB0_L	-	
B32	C_HDOUTP0_L	-	PCS 362 CH 0 OUT P	C_HDOUTP0_L	-	PCS 362 CH 0 OUT P
H37	VCC12	-		VCC12	-	
E33	C_HDINN0_L	-	PCS 362 CH 0 IN N	C_HDINN0_L	-	PCS 362 CH 0 IN N
D33	C_HDINP0_L	-	PCS 362 CH 0 IN P	C_HDINP0_L	-	PCS 362 CH 0 IN P
G31	C_VDDIB0_L	-		C_VDDIB0_L	-	
J29	VCC12	-		VCC12	-	
L29	B_REFCLKP_L	-		B_REFCLKP_L	-	
M29	B_REFCLKN_L	-		B_REFCLKN_L	-	
J31	VCC12	-		VCC12	-	
H31	B_VDDIB3_L	-		B_VDDIB3_L	-	
J30	VCC12	-		VCC12	-	
D34	B_HDINP3_L	-	PCS 361 CH 3 IN P	B_HDINP3_L	-	PCS 361 CH 3 IN P
E34	B_HDINN3_L	-	PCS 361 CH 3 IN N	B_HDINN3_L	-	PCS 361 CH 3 IN N
B33	B_HDOUTP3_L	-	PCS 361 CH 3 OUT P	B_HDOUTP3_L	-	PCS 361 CH 3 OUT P
H38	VCC12	-		VCC12	-	
A33	B_HDOUTN3_L	-	PCS 361 CH 3 OUT N	B_HDOUTN3_L	-	PCS 361 CH 3 OUT N
C38	B_VDDOB3_L	-		B_VDDOB3_L	-	
A34	B_HDOUTN2_L	-	PCS 361 CH 2 OUT N	B_HDOUTN2_L	-	PCS 361 CH 2 OUT N
L31	B_VDDOB2_L	-		B_VDDOB2_L	-	
B34	B_HDOUTP2_L	-	PCS 361 CH 2 OUT P	B_HDOUTP2_L	-	PCS 361 CH 2 OUT P
G38	VCC12	-		VCC12	-	
E35	B_HDINN2_L	-	PCS 361 CH 2 IN N	B_HDINN2_L	-	PCS 361 CH 2 IN N
D35	B_HDINP2_L	-	PCS 361 CH 2 IN P	B_HDINP2_L	-	PCS 361 CH 2 IN P
H32	B_VDDIB2_L	-		B_VDDIB2_L	-	
K29	VCC12	-		VCC12	-	
K30	B_VDDIB1_L	-		B_VDDIB1_L	-	
F33	VCC12	-		VCC12	-	
D36	B_HDINP1_L	-	PCS 361 CH 1 IN P	B_HDINP1_L	-	PCS 361 CH 1 IN P
E36	B_HDINN1_L	-	PCS 361 CH 1 IN N	B_HDINN1_L	-	PCS 361 CH 1 IN N
B35	B_HDOUTP1_L	-	PCS 361 CH 1 OUT P	B_HDOUTP1_L	-	PCS 361 CH 1 OUT P
L34	VCC12	-		VCC12	-	
A35	B_HDOUTN1_L	-	PCS 361 CH 1 OUT N	B_HDOUTN1_L	-	PCS 361 CH 1 OUT N
K35	B_VDDOB1_L	-		B_VDDOB1_L	-	
A36	B_HDOUTN0_L	-	PCS 361 CH 0 OUT N	B_HDOUTN0_L	-	PCS 361 CH 0 OUT N
G39	B_VDDOB0_L	-		B_VDDOB0_L	-	
B36	B_HDOUTP0_L	-	PCS 361 CH 0 OUT P	B_HDOUTP0_L	-	PCS 361 CH 0 OUT P
J35	VCC12	-		VCC12	-	

LFSC/M80, LFSC/M115 Logic Signal Connections: 1704 fcBGA^{1,2} (Cont.)

Ball Number	LFSC/M80			LFSC/M115		
	Ball Function	VCCIO Bank	Dual Function	Ball Function	VCCIO Bank	Dual Function
E37	B_HDINN0_L	-	PCS 361 CH 0 IN N	B_HDINN0_L	-	PCS 361 CH 0 IN N
D37	B_HDINP0_L	-	PCS 361 CH 0 IN P	B_HDINP0_L	-	PCS 361 CH 0 IN P
F34	B_VDDIB0_L	-		B_VDDIB0_L	-	
N29	VCC12	-		VCC12	-	
L30	A_VDDIB3_L	-		A_VDDIB3_L	-	
K31	VCC12	-		VCC12	-	
D38	A_HDINP3_L	-	PCS 360 CH 3 IN P	A_HDINP3_L	-	PCS 360 CH 3 IN P
E38	A_HDINN3_L	-	PCS 360 CH 3 IN N	A_HDINN3_L	-	PCS 360 CH 3 IN N
A37	A_HDOUTP3_L	-	PCS 360 CH 3 OUT P	A_HDOUTP3_L	-	PCS 360 CH 3 OUT P
G37	VCC12	-		VCC12	-	
B37	A_HDOUTN3_L	-	PCS 360 CH 3 OUT N	A_HDOUTN3_L	-	PCS 360 CH 3 OUT N
L33	A_VDDOB3_L	-		A_VDDOB3_L	-	
B38	A_HDOUTN2_L	-	PCS 360 CH 2 OUT N	A_HDOUTN2_L	-	PCS 360 CH 2 OUT N
D41	A_VDDOB2_L	-		A_VDDOB2_L	-	
A38	A_HDOUTP2_L	-	PCS 360 CH 2 OUT P	A_HDOUTP2_L	-	PCS 360 CH 2 OUT P
K34	VCC12	-		VCC12	-	
E39	A_HDINN2_L	-	PCS 360 CH 2 IN N	A_HDINN2_L	-	PCS 360 CH 2 IN N
D39	A_HDINP2_L	-	PCS 360 CH 2 IN P	A_HDINP2_L	-	PCS 360 CH 2 IN P
M32	A_VDDIB2_L	-		A_VDDIB2_L	-	
J32	VCC12	-		VCC12	-	
E41	A_VDDIB1_L	-		A_VDDIB1_L	-	
M33	VCC12	-		VCC12	-	
D40	A_HDINP1_L	-	PCS 360 CH 1 IN P	A_HDINP1_L	-	PCS 360 CH 1 IN P
E40	A_HDINN1_L	-	PCS 360 CH 1 IN N	A_HDINN1_L	-	PCS 360 CH 1 IN N
B39	A_HDOUTP1_L	-	PCS 360 CH 1 OUT P	A_HDOUTP1_L	-	PCS 360 CH 1 OUT P
B41	VCC12	-		VCC12	-	
A39	A_HDOUTN1_L	-	PCS 360 CH 1 OUT N	A_HDOUTN1_L	-	PCS 360 CH 1 OUT N
C41	A_VDDOB1_L	-		A_VDDOB1_L	-	
B40	A_HDOUTN0_L	-	PCS 360 CH 0 OUT N	A_HDOUTN0_L	-	PCS 360 CH 0 OUT N
E42	A_VDDOB0_L	-		A_VDDOB0_L	-	
A40	A_HDOUTP0_L	-	PCS 360 CH 0 OUT P	A_HDOUTP0_L	-	PCS 360 CH 0 OUT P
F42	VCC12	-		VCC12	-	
D42	A_HDINN0_L	-	PCS 360 CH 0 IN N	A_HDINN0_L	-	PCS 360 CH 0 IN N
C42	A_HDINP0_L	-	PCS 360 CH 0 IN P	A_HDINP0_L	-	PCS 360 CH 0 IN P
H39	A_VDDIB0_L	-		A_VDDIB0_L	-	
F41	VCC12	-		VCC12	-	
P16	VDDAX25_R	-		VDDAX25_R	-	
P27	VDDAX25_L	-		VDDAX25_L	-	
K39	NC	-		PL32A	7	
L39	NC	-		PL32B	7	
M38	NC	-		PL35A	7	
K40	NC	-		PL36A	7	
L40	NC	-		PL36B	7	
N37	NC	-		PL39A	7	
P37	NC	-		PL39B	7	

LFSC/M80, LFSC/M115 Logic Signal Connections: 1704 fcBGA^{1,2} (Cont.)

Ball Number	LFSC/M80			LFSC/M115		
	Ball Function	VCCIO Bank	Dual Function	Ball Function	VCCIO Bank	Dual Function
AG38	NC	-		PL95A	6	
AH38	NC	-		PL95B	6	
AJ39	NC	-		PL100A	6	
AK39	NC	-		PL100B	6	
AL41	NC	-		PL105A	6	
AM41	NC	-		PL105B	6	
AN40	NC	-		PL108A	6	
AM40	NC	-		PL108B	6	
AM39	NC	-		PL111A	6	
AN39	NC	-		PL111B	6	
AR42	NC	-		PL113A	6	
AT42	NC	-		PL113B	6	
AT1	NC	-		PR113B	3	
AR1	NC	-		PR113A	3	
AN4	NC	-		PR111B	3	
AM4	NC	-		PR111A	3	
AM3	NC	-		PR108B	3	
AN3	NC	-		PR108A	3	
AM2	NC	-		PR105B	3	
AL2	NC	-		PR105A	3	
AK4	NC	-		PR100B	3	
AJ4	NC	-		PR100A	3	
AH5	NC	-		PR95B	3	
AG5	NC	-		PR95A	3	
P6	NC	-		PR39B	2	
N6	NC	-		PR39A	2	
L3	NC	-		PR36B	2	
K3	NC	-		PR36A	2	
M5	NC	-		PR35A	2	
L4	NC	-		PR32B	2	
K4	NC	-		PR32A	2	
A2	GND	-		GND	-	
A41	GND	-		GND	-	
AA20	GND	-		GND	-	
AA23	GND	-		GND	-	
AA3	GND	-		GND	-	
AA39	GND	-		GND	-	
AB20	GND	-		GND	-	
AB23	GND	-		GND	-	
AB4	GND	-		GND	-	
AB40	GND	-		GND	-	
AC17	GND	-		GND	-	
AC19	GND	-		GND	-	
AC21	GND	-		GND	-	
AC22	GND	-		GND	-	

LFSC/M80, LFSC/M115 Logic Signal Connections: 1704 fcBGA^{1,2} (Cont.)

Ball Number	LFSC/M80			LFSC/M115		
	Ball Function	VCCIO Bank	Dual Function	Ball Function	VCCIO Bank	Dual Function
AC24	GND	-		GND	-	
AC26	GND	-		GND	-	
AC35	GND	-		GND	-	
AC8	GND	-		GND	-	
AD12	GND	-		GND	-	
AD16	GND	-		GND	-	
AD18	GND	-		GND	-	
AD20	GND	-		GND	-	
AD23	GND	-		GND	-	
AD25	GND	-		GND	-	
AD27	GND	-		GND	-	
AD31	GND	-		GND	-	
AE17	GND	-		GND	-	
AE19	GND	-		GND	-	
AE24	GND	-		GND	-	
AE26	GND	-		GND	-	
AE3	GND	-		GND	-	
AE39	GND	-		GND	-	
AF18	GND	-		GND	-	
AF20	GND	-		GND	-	
AF23	GND	-		GND	-	
AF25	GND	-		GND	-	
AF36	GND	-		GND	-	
AF7	GND	-		GND	-	
AG11	GND	-		GND	-	
AG16	GND	-		GND	-	
AG19	GND	-		GND	-	
AG24	GND	-		GND	-	
AG27	GND	-		GND	-	
AG32	GND	-		GND	-	
AH15	GND	-		GND	-	
AH28	GND	-		GND	-	
AH4	GND	-		GND	-	
AH40	GND	-		GND	-	
AJ35	GND	-		GND	-	
AJ8	GND	-		GND	-	
AK12	GND	-		GND	-	
AK31	GND	-		GND	-	
AL13	GND	-		GND	-	
AL19	GND	-		GND	-	
AL24	GND	-		GND	-	
AL3	GND	-		GND	-	
AL30	GND	-		GND	-	
AL39	GND	-		GND	-	
AM16	GND	-		GND	-	

LFSC/M80, LFSC/M115 Logic Signal Connections: 1704 fcBGA^{1,2} (Cont.)

Ball Number	LFSC/M80			LFSC/M115		
	Ball Function	VCCIO Bank	Dual Function	Ball Function	VCCIO Bank	Dual Function
AM27	GND	-		GND	-	
AM36	GND	-		GND	-	
AM7	GND	-		GND	-	
AP4	GND	-		GND	-	
AP40	GND	-		GND	-	
AR14	GND	-		GND	-	
AR20	GND	-		GND	-	
AR23	GND	-		GND	-	
AR29	GND	-		GND	-	
AR35	GND	-		GND	-	
AR8	GND	-		GND	-	
AT11	GND	-		GND	-	
AT17	GND	-		GND	-	
AT26	GND	-		GND	-	
AT32	GND	-		GND	-	
AU3	GND	-		GND	-	
AU39	GND	-		GND	-	
AW12	GND	-		GND	-	
AW18	GND	-		GND	-	
AW22	GND	-		GND	-	
AW28	GND	-		GND	-	
AW34	GND	-		GND	-	
AW6	GND	-		GND	-	
AY15	GND	-		GND	-	
AY21	GND	-		GND	-	
AY25	GND	-		GND	-	
AY31	GND	-		GND	-	
AY37	GND	-		GND	-	
AY9	GND	-		GND	-	
B1	GND	-		GND	-	
B42	GND	-		GND	-	
BA1	GND	-		GND	-	
BA42	GND	-		GND	-	
BB2	GND	-		GND	-	
BB41	GND	-		GND	-	
C10	GND	-		GND	-	
C12	GND	-		GND	-	
C13	GND	-		GND	-	
C16	GND	-		GND	-	
C18	GND	-		GND	-	
C19	GND	-		GND	-	
C22	GND	-		GND	-	
C24	GND	-		GND	-	
C27	GND	-		GND	-	
C28	GND	-		GND	-	

LFSC/M80, LFSC/M115 Logic Signal Connections: 1704 fcBGA^{1,2} (Cont.)

Ball Number	LFSC/M80			LFSC/M115		
	Ball Function	VCCIO Bank	Dual Function	Ball Function	VCCIO Bank	Dual Function
C3	GND	-		GND	-	
C30	GND	-		GND	-	
C33	GND	-		GND	-	
C35	GND	-		GND	-	
C36	GND	-		GND	-	
C39	GND	-		GND	-	
C4	GND	-		GND	-	
C40	GND	-		GND	-	
C7	GND	-		GND	-	
C8	GND	-		GND	-	
D15	GND	-		GND	-	
D21	GND	-		GND	-	
D25	GND	-		GND	-	
D31	GND	-		GND	-	
F4	GND	-		GND	-	
F40	GND	-		GND	-	
G11	GND	-		GND	-	
G17	GND	-		GND	-	
G26	GND	-		GND	-	
G32	GND	-		GND	-	
H14	GND	-		GND	-	
H20	GND	-		GND	-	
H23	GND	-		GND	-	
H29	GND	-		GND	-	
H35	GND	-		GND	-	
H8	GND	-		GND	-	
J3	GND	-		GND	-	
J39	GND	-		GND	-	
L16	GND	-		GND	-	
L27	GND	-		GND	-	
L36	GND	-		GND	-	
L7	GND	-		GND	-	
M19	GND	-		GND	-	
M24	GND	-		GND	-	
M4	GND	-		GND	-	
M40	GND	-		GND	-	
N12	GND	-		GND	-	
N31	GND	-		GND	-	
P35	GND	-		GND	-	
P8	GND	-		GND	-	
R15	GND	-		GND	-	
R28	GND	-		GND	-	
R3	GND	-		GND	-	
R39	GND	-		GND	-	
T11	GND	-		GND	-	

LFSC/M80, LFSC/M115 Logic Signal Connections: 1704 fcBGA^{1,2} (Cont.)

Ball Number	LFSC/M80			LFSC/M115		
	Ball Function	VCCIO Bank	Dual Function	Ball Function	VCCIO Bank	Dual Function
T16	GND	-		GND	-	
T19	GND	-		GND	-	
T24	GND	-		GND	-	
T27	GND	-		GND	-	
T32	GND	-		GND	-	
U18	GND	-		GND	-	
U20	GND	-		GND	-	
U23	GND	-		GND	-	
U25	GND	-		GND	-	
U36	GND	-		GND	-	
U7	GND	-		GND	-	
G36	GND	-		GND	-	
G7	GND	-		GND	-	
V17	GND	-		GND	-	
V19	GND	-		GND	-	
V24	GND	-		GND	-	
V26	GND	-		GND	-	
V4	GND	-		GND	-	
V40	GND	-		GND	-	
W12	GND	-		GND	-	
W16	GND	-		GND	-	
W18	GND	-		GND	-	
W20	GND	-		GND	-	
W23	GND	-		GND	-	
W25	GND	-		GND	-	
W27	GND	-		GND	-	
W31	GND	-		GND	-	
Y17	GND	-		GND	-	
Y19	GND	-		GND	-	
Y21	GND	-		GND	-	
Y22	GND	-		GND	-	
AA17	VCC	-		VCC	-	
AA18	VCC	-		VCC	-	
AA19	VCC	-		VCC	-	
AA21	VCC	-		VCC	-	
AA22	VCC	-		VCC	-	
AA24	VCC	-		VCC	-	
AA25	VCC	-		VCC	-	
AA26	VCC	-		VCC	-	
AB17	VCC	-		VCC	-	
AB18	VCC	-		VCC	-	
AB19	VCC	-		VCC	-	
AB21	VCC	-		VCC	-	
AB22	VCC	-		VCC	-	
AB24	VCC	-		VCC	-	

LFSC/M80, LFSC/M115 Logic Signal Connections: 1704 fcBGA^{1,2} (Cont.)

Ball Number	LFSC/M80			LFSC/M115		
	Ball Function	VCCIO Bank	Dual Function	Ball Function	VCCIO Bank	Dual Function
AB25	VCC	-		VCC	-	
AB26	VCC	-		VCC	-	
AC16	VCC	-		VCC	-	
AC18	VCC	-		VCC	-	
AC20	VCC	-		VCC	-	
AC23	VCC	-		VCC	-	
AC25	VCC	-		VCC	-	
AC27	VCC	-		VCC	-	
AD17	VCC	-		VCC	-	
AD19	VCC	-		VCC	-	
AD21	VCC	-		VCC	-	
AD22	VCC	-		VCC	-	
AD24	VCC	-		VCC	-	
AD26	VCC	-		VCC	-	
AE16	VCC	-		VCC	-	
AE18	VCC	-		VCC	-	
AE20	VCC	-		VCC	-	
AE21	VCC	-		VCC	-	
AE22	VCC	-		VCC	-	
AE23	VCC	-		VCC	-	
AE25	VCC	-		VCC	-	
AE27	VCC	-		VCC	-	
AF17	VCC	-		VCC	-	
AF19	VCC	-		VCC	-	
AF21	VCC	-		VCC	-	
AF22	VCC	-		VCC	-	
AF24	VCC	-		VCC	-	
AF26	VCC	-		VCC	-	
AG18	VCC	-		VCC	-	
AG20	VCC	-		VCC	-	
AG23	VCC	-		VCC	-	
AG25	VCC	-		VCC	-	
T18	VCC	-		VCC	-	
T20	VCC	-		VCC	-	
T23	VCC	-		VCC	-	
T25	VCC	-		VCC	-	
U17	VCC	-		VCC	-	
U19	VCC	-		VCC	-	
U21	VCC	-		VCC	-	
U22	VCC	-		VCC	-	
U24	VCC	-		VCC	-	
U26	VCC	-		VCC	-	
V16	VCC	-		VCC	-	
V18	VCC	-		VCC	-	
V20	VCC	-		VCC	-	

LFSC/M80, LFSC/M115 Logic Signal Connections: 1704 fcBGA^{1,2} (Cont.)

Ball Number	LFSC/M80			LFSC/M115		
	Ball Function	VCCIO Bank	Dual Function	Ball Function	VCCIO Bank	Dual Function
V21	VCC	-		VCC	-	
V22	VCC	-		VCC	-	
V23	VCC	-		VCC	-	
V25	VCC	-		VCC	-	
V27	VCC	-		VCC	-	
W17	VCC	-		VCC	-	
W19	VCC	-		VCC	-	
W21	VCC	-		VCC	-	
W22	VCC	-		VCC	-	
W24	VCC	-		VCC	-	
W26	VCC	-		VCC	-	
Y16	VCC	-		VCC	-	
Y18	VCC	-		VCC	-	
Y20	VCC	-		VCC	-	
Y23	VCC	-		VCC	-	
Y25	VCC	-		VCC	-	
Y27	VCC	-		VCC	-	
AG22	VCC12	-		VCC12	-	
AG26	VCC12	-		VCC12	-	
T17	VCC12	-		VCC12	-	
T21	VCC12	-		VCC12	-	
T22	VCC12	-		VCC12	-	
T26	VCC12	-		VCC12	-	
U16	VCC12	-		VCC12	-	
U27	VCC12	-		VCC12	-	
AC15	VCCAUX	-		VCCAUX	-	
AC28	VCCAUX	-		VCCAUX	-	
AD15	VCCAUX	-		VCCAUX	-	
AD28	VCCAUX	-		VCCAUX	-	
AE15	VCCAUX	-		VCCAUX	-	
AE28	VCCAUX	-		VCCAUX	-	
AF15	VCCAUX	-		VCCAUX	-	
AF28	VCCAUX	-		VCCAUX	-	
AG15	VCCAUX	-		VCCAUX	-	
AG28	VCCAUX	-		VCCAUX	-	
AH14	VCCAUX	-		VCCAUX	-	
AH16	VCCAUX	-		VCCAUX	-	
AH17	VCCAUX	-		VCCAUX	-	
AH18	VCCAUX	-		VCCAUX	-	
AH19	VCCAUX	-		VCCAUX	-	
AH20	VCCAUX	-		VCCAUX	-	
AH23	VCCAUX	-		VCCAUX	-	
AH24	VCCAUX	-		VCCAUX	-	
AH25	VCCAUX	-		VCCAUX	-	
AH26	VCCAUX	-		VCCAUX	-	

LFSC/M80, LFSC/M115 Logic Signal Connections: 1704 fcBGA^{1,2} (Cont.)

Ball Number	LFSC/M80			LFSC/M115		
	Ball Function	VCCIO Bank	Dual Function	Ball Function	VCCIO Bank	Dual Function
AH27	VCCAUX	-		VCCAUX	-	
AH29	VCCAUX	-		VCCAUX	-	
AJ14	VCCAUX	-		VCCAUX	-	
AJ15	VCCAUX	-		VCCAUX	-	
AJ28	VCCAUX	-		VCCAUX	-	
AJ29	VCCAUX	-		VCCAUX	-	
P14	VCCAUX	-		VCCAUX	-	
P15	VCCAUX	-		VCCAUX	-	
P28	VCCAUX	-		VCCAUX	-	
P29	VCCAUX	-		VCCAUX	-	
R14	VCCAUX	-		VCCAUX	-	
R16	VCCAUX	-		VCCAUX	-	
R17	VCCAUX	-		VCCAUX	-	
R18	VCCAUX	-		VCCAUX	-	
R19	VCCAUX	-		VCCAUX	-	
R20	VCCAUX	-		VCCAUX	-	
R23	VCCAUX	-		VCCAUX	-	
R24	VCCAUX	-		VCCAUX	-	
R25	VCCAUX	-		VCCAUX	-	
R26	VCCAUX	-		VCCAUX	-	
R27	VCCAUX	-		VCCAUX	-	
R29	VCCAUX	-		VCCAUX	-	
T15	VCCAUX	-		VCCAUX	-	
T28	VCCAUX	-		VCCAUX	-	
U15	VCCAUX	-		VCCAUX	-	
U28	VCCAUX	-		VCCAUX	-	
V15	VCCAUX	-		VCCAUX	-	
V28	VCCAUX	-		VCCAUX	-	
W15	VCCAUX	-		VCCAUX	-	
W28	VCCAUX	-		VCCAUX	-	
Y15	VCCAUX	-		VCCAUX	-	
Y28	VCCAUX	-		VCCAUX	-	
F3	VCCIO1	-		VCCIO1	-	
F39	VCCIO1	-		VCCIO1	-	
G35	VCCIO1	-		VCCIO1	-	
G8	VCCIO1	-		VCCIO1	-	
L19	VCCIO1	-		VCCIO1	-	
L24	VCCIO1	-		VCCIO1	-	
M16	VCCIO1	-		VCCIO1	-	
M27	VCCIO1	-		VCCIO1	-	
N11	VCCIO1	-		VCCIO1	-	
N32	VCCIO1	-		VCCIO1	-	
AA4	VCCIO2	-		VCCIO2	-	
H7	VCCIO2	-		VCCIO2	-	
J4	VCCIO2	-		VCCIO2	-	

LFSC/M80, LFSC/M115 Logic Signal Connections: 1704 fcBGA^{1,2} (Cont.)

Ball Number	LFSC/M80			LFSC/M115		
	Ball Function	VCCIO Bank	Dual Function	Ball Function	VCCIO Bank	Dual Function
L8	VCCIO2	-		VCCIO2	-	
M3	VCCIO2	-		VCCIO2	-	
P7	VCCIO2	-		VCCIO2	-	
R4	VCCIO2	-		VCCIO2	-	
T12	VCCIO2	-		VCCIO2	-	
U8	VCCIO2	-		VCCIO2	-	
V3	VCCIO2	-		VCCIO2	-	
W11	VCCIO2	-		VCCIO2	-	
Y7	VCCIO2	-		VCCIO2	-	
AB3	VCCIO3	-		VCCIO3	-	
AC7	VCCIO3	-		VCCIO3	-	
AD11	VCCIO3	-		VCCIO3	-	
AE4	VCCIO3	-		VCCIO3	-	
AF8	VCCIO3	-		VCCIO3	-	
AG12	VCCIO3	-		VCCIO3	-	
AH3	VCCIO3	-		VCCIO3	-	
AJ7	VCCIO3	-		VCCIO3	-	
AK11	VCCIO3	-		VCCIO3	-	
AL4	VCCIO3	-		VCCIO3	-	
AM8	VCCIO3	-		VCCIO3	-	
AP3	VCCIO3	-		VCCIO3	-	
AR7	VCCIO3	-		VCCIO3	-	
AU4	VCCIO3	-		VCCIO3	-	
AL16	VCCIO4	-		VCCIO4	-	
AM13	VCCIO4	-		VCCIO4	-	
AM19	VCCIO4	-		VCCIO4	-	
AR11	VCCIO4	-		VCCIO4	-	
AR17	VCCIO4	-		VCCIO4	-	
AT14	VCCIO4	-		VCCIO4	-	
AT20	VCCIO4	-		VCCIO4	-	
AT8	VCCIO4	-		VCCIO4	-	
AW15	VCCIO4	-		VCCIO4	-	
AW21	VCCIO4	-		VCCIO4	-	
AW9	VCCIO4	-		VCCIO4	-	
AY12	VCCIO4	-		VCCIO4	-	
AY18	VCCIO4	-		VCCIO4	-	
AY6	VCCIO4	-		VCCIO4	-	
AL27	VCCIO5	-		VCCIO5	-	
AM24	VCCIO5	-		VCCIO5	-	
AM30	VCCIO5	-		VCCIO5	-	
AR26	VCCIO5	-		VCCIO5	-	
AR32	VCCIO5	-		VCCIO5	-	
AT23	VCCIO5	-		VCCIO5	-	
AT29	VCCIO5	-		VCCIO5	-	
AT35	VCCIO5	-		VCCIO5	-	

LFSC/M80, LFSC/M115 Logic Signal Connections: 1704 fcBGA^{1,2} (Cont.)

Ball Number	LFSC/M80			LFSC/M115		
	Ball Function	VCCIO Bank	Dual Function	Ball Function	VCCIO Bank	Dual Function
AW25	VCCIO5	-		VCCIO5	-	
AW31	VCCIO5	-		VCCIO5	-	
AW37	VCCIO5	-		VCCIO5	-	
AY22	VCCIO5	-		VCCIO5	-	
AY28	VCCIO5	-		VCCIO5	-	
AY34	VCCIO5	-		VCCIO5	-	
AB39	VCCIO6	-		VCCIO6	-	
AC36	VCCIO6	-		VCCIO6	-	
AD32	VCCIO6	-		VCCIO6	-	
AE40	VCCIO6	-		VCCIO6	-	
AF35	VCCIO6	-		VCCIO6	-	
AG31	VCCIO6	-		VCCIO6	-	
AH39	VCCIO6	-		VCCIO6	-	
AJ36	VCCIO6	-		VCCIO6	-	
AK32	VCCIO6	-		VCCIO6	-	
AL40	VCCIO6	-		VCCIO6	-	
AM35	VCCIO6	-		VCCIO6	-	
AP39	VCCIO6	-		VCCIO6	-	
AR36	VCCIO6	-		VCCIO6	-	
AU40	VCCIO6	-		VCCIO6	-	
AA40	VCCIO7	-		VCCIO7	-	
H36	VCCIO7	-		VCCIO7	-	
J40	VCCIO7	-		VCCIO7	-	
L35	VCCIO7	-		VCCIO7	-	
M39	VCCIO7	-		VCCIO7	-	
P36	VCCIO7	-		VCCIO7	-	
R40	VCCIO7	-		VCCIO7	-	
T31	VCCIO7	-		VCCIO7	-	
U35	VCCIO7	-		VCCIO7	-	
V39	VCCIO7	-		VCCIO7	-	
W32	VCCIO7	-		VCCIO7	-	
Y36	VCCIO7	-		VCCIO7	-	
AA14	VTT_2	2		VTT_2	2	
AA15	VTT_2	2		VTT_2	2	
R12	VTT_2	2		VTT_2	2	
V14	VTT_2	2		VTT_2	2	
AB14	VTT_3	3		VTT_3	3	
AB15	VTT_3	3		VTT_3	3	
AE14	VTT_3	3		VTT_3	3	
AJ13	VTT_3	3		VTT_3	3	
AH21	VTT_4	4		VTT_4	4	
AJ18	VTT_4	4		VTT_4	4	
AJ19	VTT_4	4		VTT_4	4	
AJ20	VTT_4	4		VTT_4	4	
AJ21	VTT_4	4		VTT_4	4	

LFSC/M80, LFSC/M115 Logic Signal Connections: 1704 fcBGA^{1,2} (Cont.)

Ball Number	LFSC/M80			LFSC/M115		
	Ball Function	VCCIO Bank	Dual Function	Ball Function	VCCIO Bank	Dual Function
AH22	VTT_5	5		VTT_5	5	
AJ22	VTT_5	5		VTT_5	5	
AJ23	VTT_5	5		VTT_5	5	
AJ24	VTT_5	5		VTT_5	5	
AJ25	VTT_5	5		VTT_5	5	
AB28	VTT_6	6		VTT_6	6	
AB29	VTT_6	6		VTT_6	6	
AE29	VTT_6	6		VTT_6	6	
AJ30	VTT_6	6		VTT_6	6	
AA28	VTT_7	7		VTT_7	7	
AA29	VTT_7	7		VTT_7	7	
R31	VTT_7	7		VTT_7	7	
V29	VTT_7	7		VTT_7	7	
Y24	GND	-		GND	-	
Y26	GND	-		GND	-	
Y8	GND	-		GND	-	
Y35	GND	-		GND	-	
AA16	VCC12	-		VCC12	-	
AA27	VCC12	-		VCC12	-	
AB16	VCC12	-		VCC12	-	
AB27	VCC12	-		VCC12	-	
AF16	VCC12	-		VCC12	-	
AF27	VCC12	-		VCC12	-	
AG17	VCC12	-		VCC12	-	
AG21	VCC12	-		VCC12	-	
G33	NC	-		NC	-	
G10	NC	-		NC	-	
M15	NC	-		NC	-	
L15	NC	-		NC	-	
K16	NC	-		NC	-	
J16	NC	-		NC	-	
M18	NC	-		NC	-	
L18	NC	-		NC	-	
M25	NC	-		NC	-	
L25	NC	-		NC	-	
J27	NC	-		NC	-	
K27	NC	-		NC	-	
L28	NC	-		NC	-	
M28	NC	-		NC	-	

1. Differential pair grouping within a PIC is A (True) and B (Complement) and C (True) and D (Complement).
2. The LatticeSC/M80 and LatticeSC/M115 in a 1704-pin package supports a 32-bit MPI interface.

Thermal Management

Thermal management is recommended as part of any sound FPGA design methodology. To assess the thermal characteristics of a system, Lattice specifies a maximum allowable junction temperature in all device data sheets. Designers must complete a thermal analysis of their specific design to ensure that the device and package do not exceed the junction temperature limits. Refer to the Thermal Management document to find the device/package specific thermal values.

For Further Information

For further information regarding Thermal Management, refer to the following located on the Lattice website at www.latticesemi.com.

- Thermal Management document
- Technical Note TN1101 - Power Estimation and Management for LatticeSC Devices
- Power Calculator tool included with Lattice's ispLEVER design tool, or as a standalone download from www.latticesemi.com/software

Part Number Description

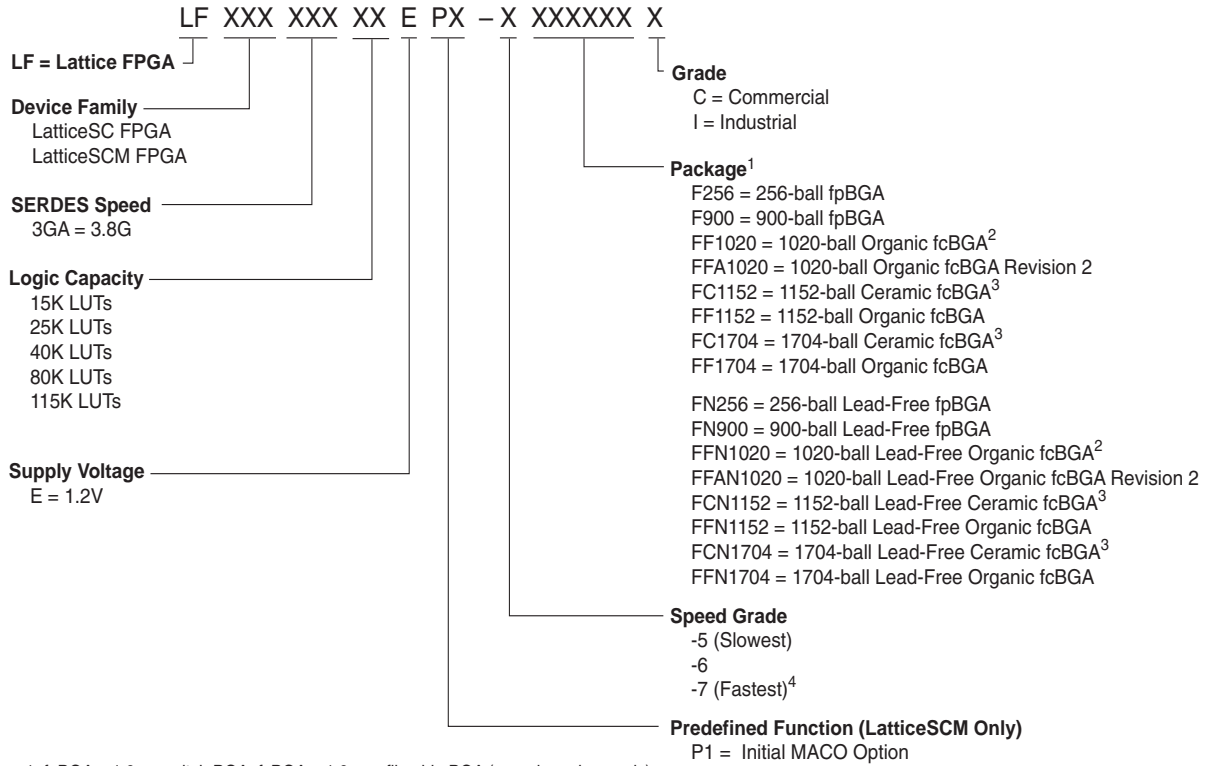

1. fpBGA = 1.0 mm pitch BGA, fcBGA = 1.0 mm flip-chip BGA (organic and ceramic).
2. Converted to organic fcBGA per PCN #02A-10.
3. Converted to organic fcBGA per PCN #01A-10.
4. Not available in the LatticeSC115 and LatticeSCM115 devices.

Ordering Information

Depending on the speed and temperature grade, the device can either be dual marked or single marked. The commercial grade is one speed grade faster than the associated dual marked industrial grade. The slowest commercial speed grade does not have industrial markings. The markings appear as follows:

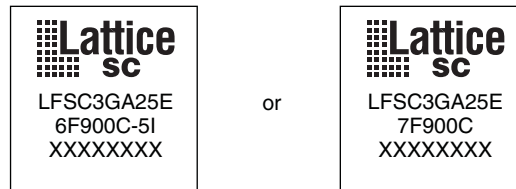

Temperature Grade	Speed Grade	Single or Dual Mark?
Commercial	-7	Either OK
	-6	Dual Only
	-5	Single Only
Industrial	-6	Either OK
	-5	Dual Only

Conventional Packaging

Commercial

Part Number	Grade	Package	Balls	Temp.	LUTs (K)
LFSC3GA15E-7F256C	-7	fpBGA	256	COM	15.2
LFSC3GA15E-6F256C	-6	fpBGA	256	COM	15.2
LFSC3GA15E-5F256C	-5	fpBGA	256	COM	15.2
LFSC3GA15E-7F900C	-7	fpBGA	900	COM	15.2
LFSC3GA15E-6F900C	-6	fpBGA	900	COM	15.2
LFSC3GA15E-5F900C	-5	fpBGA	900	COM	15.2

Part Number	Grade	Package	Balls	Temp.	LUTs (K)
LFSCM3GA15EP1-7F256C	-7	fpBGA	256	COM	15.2
LFSCM3GA15EP1-6F256C	-6	fpBGA	256	COM	15.2
LFSCM3GA15EP1-5F256C	-5	fpBGA	256	COM	15.2
LFSCM3GA15EP1-7F900C	-7	fpBGA	900	COM	15.2
LFSCM3GA15EP1-6F900C	-6	fpBGA	900	COM	15.2
LFSCM3GA15EP1-5F900C	-5	fpBGA	900	COM	15.2

Part Number	Grade	Package	Balls	Temp.	LUTs (K)
LFSC3GA25E-7F900C	-7	fpBGA	900	COM	25.4
LFSC3GA25E-6F900C	-6	fpBGA	900	COM	25.4
LFSC3GA25E-5F900C	-5	fpBGA	900	COM	25.4
LFSC3GA25E-7FF1020C ¹	-7	Organic fcBGA	1020	COM	25.4
LFSC3GA25E-6FF1020C ¹	-6	Organic fcBGA	1020	COM	25.4
LFSC3GA25E-5FF1020C ¹	-5	Organic fcBGA	1020	COM	25.4
LFSC3GA25E-7FFA1020C	-7	Organic fcBGA Revision 2	1020	COM	25.4
LFSC3GA25E-6FFA1020C	-6	Organic fcBGA Revision 2	1020	COM	25.4
LFSC3GA25E-5FFA1020C	-5	Organic fcBGA Revision 2	1020	COM	25.4

1. Converted to organic flip-chip BGA package revision 2 per [PCN #02A-10](#).

Part Number	Grade	Package	Balls	Temp.	LUTs (K)
LFSCM3GA25EP1-7F900C	-7	fpBGA	900	COM	25.4
LFSCM3GA25EP1-6F900C	-6	fpBGA	900	COM	25.4
LFSCM3GA25EP1-5F900C	-5	fpBGA	900	COM	25.4
LFSCM3GA25EP1-7FF1020C ¹	-7	Organic fcBGA	1020	COM	25.4
LFSCM3GA25EP1-6FF1020C ¹	-6	Organic fcBGA	1020	COM	25.4
LFSCM3GA25EP1-5FF1020C ¹	-5	Organic fcBGA	1020	COM	25.4
LFSCM3GA25EP1-7FFA1020C	-7	Organic fcBGA Revision 2	1020	COM	25.4
LFSCM3GA25EP1-6FFA1020C	-6	Organic fcBGA Revision 2	1020	COM	25.4
LFSCM3GA25EP1-5FFA1020C	-5	Organic fcBGA Revision 2	1020	COM	25.4

1. Converted to organic flip-chip BGA package revision 2 per [PCN #02A-10](#).

Commercial, Cont.

Part Number	Grade	Package	Balls	Temp.	LUTs (K)
LFSC3GA40E-7FF1020C ¹	-7	Organic fcBGA	1020	COM	40.4
LFSC3GA40E-6FF1020C ¹	-6	Organic fcBGA	1020	COM	40.4
LFSC3GA40E-5FF1020C ¹	-5	Organic fcBGA	1020	COM	40.4
LFSC3GA40E-7FFA1020C	-7	Organic fcBGA Revision 2	1020	COM	40.4
LFSC3GA40E-6FFA1020C	-6	Organic fcBGA Revision 2	1020	COM	40.4
LFSC3GA40E-5FFA1020C	-5	Organic fcBGA Revision 2	1020	COM	40.4
LFSC3GA40E-7FC1152C ²	-7	Ceramic fcBGA	1152	COM	40.4
LFSC3GA40E-6FC1152C ²	-6	Ceramic fcBGA	1152	COM	40.4
LFSC3GA40E-5FC1152C ²	-5	Ceramic fcBGA	1152	COM	40.4
LFSC3GA40E-7FF1152C	-7	Organic fcBGA	1152	COM	40.4
LFSC3GA40E-6FF1152C	-6	Organic fcBGA	1152	COM	40.4
LFSC3GA40E-5FF1152C	-5	Organic fcBGA	1152	COM	40.4

1. Converted to organic flip-chip BGA package revision 2 per [PCN #02A-10](#).

2. Converted to organic flip-chip BGA package per [PCN #01A-10](#).

Part Number	Grade	Package	Balls	Temp.	LUTs (K)
LFSCM3GA40EP1-7FF1020C ¹	-7	Organic fcBGA	1020	COM	40.4
LFSCM3GA40EP1-6FF1020C ¹	-6	Organic fcBGA	1020	COM	40.4
LFSCM3GA40EP1-5FF1020C ¹	-5	Organic fcBGA	1020	COM	40.4
LFSCM3GA40EP1-7FFA1020C	-7	Organic fcBGA Revision 2	1020	COM	40.4
LFSCM3GA40EP1-6FFA1020C	-6	Organic fcBGA Revision 2	1020	COM	40.4
LFSCM3GA40EP1-5FFA1020C	-5	Organic fcBGA Revision 2	1020	COM	40.4
LFSCM3GA40EP1-7FC1152C ²	-7	Ceramic fcBGA	1152	COM	40.4
LFSCM3GA40EP1-6FC1152C ²	-6	Ceramic fcBGA	1152	COM	40.4
LFSCM3GA40EP1-5FC1152C ²	-5	Ceramic fcBGA	1152	COM	40.4
LFSCM3GA40EP1-7FF1152C	-7	Organic fcBGA	1152	COM	40.4
LFSCM3GA40EP1-6FF1152C	-6	Organic fcBGA	1152	COM	40.4
LFSCM3GA40EP1-5FF1152C	-5	Organic fcBGA	1152	COM	40.4

1. Converted to organic flip-chip BGA package revision 2 per [PCN #02A-10](#).

2. Converted to organic flip-chip BGA package per [PCN #01A-10](#).

Commercial, Cont.

Part Number	Grade	Package	Balls	Temp.	LUTs (K)
LFSC3GA80E-7FC1152C ¹	-7	Ceramic fcBGA	1152	COM	80.1
LFSC3GA80E-6FC1152C ¹	-6	Ceramic fcBGA	1152	COM	80.1
LFSC3GA80E-5FC1152C ¹	-5	Ceramic fcBGA	1152	COM	80.1
LFSC3GA80E-7FF1152C	-7	Organic fcBGA	1152	COM	80.1
LFSC3GA80E-6FF1152C	-6	Organic fcBGA	1152	COM	80.1
LFSC3GA80E-5FF1152C	-5	Organic fcBGA	1152	COM	80.1
LFSC3GA80E-7FC1704C ¹	-7	Ceramic fcBGA	1704	COM	80.1
LFSC3GA80E-6FC1704C ¹	-6	Ceramic fcBGA	1704	COM	80.1
LFSC3GA80E-5FC1704C ¹	-5	Ceramic fcBGA	1704	COM	80.1
LFSC3GA80E-7FF1704C	-7	Organic fcBGA	1704	COM	80.1
LFSC3GA80E-6FF1704C	-6	Organic fcBGA	1704	COM	80.1
LFSC3GA80E-5FF1704C	-5	Organic fcBGA	1704	COM	80.1

1. Converted to organic flip-chip BGA package per [PCN #01A-10](#).

Part Number	Grade	Package	Balls	Temp.	LUTs (K)
LFSCM3GA80EP1-7FC1152C ¹	-7	Ceramic fcBGA	1152	COM	80.1
LFSCM3GA80EP1-6FC1152C ¹	-6	Ceramic fcBGA	1152	COM	80.1
LFSCM3GA80EP1-5FC1152C ¹	-5	Ceramic fcBGA	1152	COM	80.1
LFSCM3GA80EP1-7FF1152C	-7	Organic fcBGA	1152	COM	80.1
LFSCM3GA80EP1-6FF1152C	-6	Organic fcBGA	1152	COM	80.1
LFSCM3GA80EP1-5FF1152C	-5	Organic fcBGA	1152	COM	80.1
LFSCM3GA80EP1-7FC1704C ¹	-7	Ceramic fcBGA	1704	COM	80.1
LFSCM3GA80EP1-6FC1704C ¹	-6	Ceramic fcBGA	1704	COM	80.1
LFSCM3GA80EP1-5FC1704C ¹	-5	Ceramic fcBGA	1704	COM	80.1
LFSCM3GA80EP1-7FF1704C	-7	Organic fcBGA	1704	COM	80.1
LFSCM3GA80EP1-6FF1704C	-6	Organic fcBGA	1704	COM	80.1
LFSCM3GA80EP1-5FF1704C	-5	Organic fcBGA	1704	COM	80.1

1. Converted to organic flip-chip BGA package per [PCN #01A-10](#).

Part Number	Grade	Package	Balls	Temp.	LUTs (K)
LFSC3GA115E-6FC1152C ¹	-6	Ceramic fcBGA	1152	COM	115.2
LFSC3GA115E-5FC1152C ¹	-5	Ceramic fcBGA	1152	COM	115.2
LFSC3GA115E-6FF1152C	-6	Organic fcBGA	1152	COM	115.2
LFSC3GA115E-5FF1152C	-5	Organic fcBGA	1152	COM	115.2
LFSC3GA115E-6FC1704C ¹	-6	Ceramic fcBGA	1704	COM	115.2
LFSC3GA115E-5FC1704C ¹	-5	Ceramic fcBGA	1704	COM	115.2
LFSC3GA115E-6FF1704C	-6	Organic fcBGA	1704	COM	115.2
LFSC3GA115E-5FF1704C	-5	Organic fcBGA	1704	COM	115.2

1. Converted to organic flip-chip BGA package per [PCN #01A-10](#).

Commercial, Cont.

Part Number	Grade	Package	Balls	Temp.	LUTs (K)
LFSCM3GA115EP1-6FC1152C ¹	-6	Ceramic fcBGA	1152	COM	115.2
LFSCM3GA115EP1-5FC1152C ¹	-5	Ceramic fcBGA	1152	COM	115.2
LFSCM3GA115EP1-6FF1152C	-6	Organic fcBGA	1152	COM	115.2
LFSCM3GA115EP1-5FF1152C	-5	Organic fcBGA	1152	COM	115.2
LFSCM3GA115EP1-6FC1704C ¹	-6	Ceramic fcBGA	1704	COM	115.2
LFSCM3GA115EP1-5FC1704C ¹	-5	Ceramic fcBGA	1704	COM	115.2
LFSCM3GA115EP1-6FF1704C	-6	Organic fcBGA	1704	COM	115.2
LFSCM3GA115EP1-5FF1704C	-5	Organic fcBGA	1704	COM	115.2

1. Converted to organic flip-chip BGA package per [PCN #01A-10](#).

Industrial

Part Number	Grade	Package	Balls	Temp.	LUTs (K)
LFSC3GA15E-6F256I	-6	fpBGA	256	IND	15.2
LFSC3GA15E-5F256I	-5	fpBGA	256	IND	15.2
LFSC3GA15E-6F900I	-6	fpBGA	900	IND	15.2
LFSC3GA15E-5F900I	-5	fpBGA	900	IND	15.2

Part Number	Grade	Package	Balls	Temp.	LUTs (K)
LFSCM3GA15EP1-6F256I	-6	fpBGA	256	IND	15.2
LFSCM3GA15EP1-5F256I	-5	fpBGA	256	IND	15.2
LFSCM3GA15EP1-6F900I	-6	fpBGA	900	IND	15.2
LFSCM3GA15EP1-5F900I	-5	fpBGA	900	IND	15.2

Part Number	Grade	Package	Balls	Temp.	LUTs (K)
LFSC3GA25E-6F900I	-6	fpBGA	900	IND	25.4
LFSC3GA25E-5F900I	-5	fpBGA	900	IND	25.4
LFSC3GA25E-6FF1020I ¹	-6	Organic fcBGA	1020	IND	25.4
LFSC3GA25E-5FF1020I ¹	-5	Organic fcBGA	1020	IND	25.4
LFSC3GA25E-6FFA1020I	-6	Organic fcBGA Revision 2	1020	IND	25.4
LFSC3GA25E-5FFA1020I	-5	Organic fcBGA Revision 2	1020	IND	25.4

1. Converted to organic flip-chip BGA package revision 2 per [PCN #02A-10](#).

Part Number	Grade	Package	Balls	Temp.	LUTs (K)
LFSCM3GA25EP1-6F900I	-6	fpBGA	900	IND	25.4
LFSCM3GA25EP1-5F900I	-5	fpBGA	900	IND	25.4
LFSCM3GA25EP1-6FF1020I ¹	-6	Organic fcBGA	1020	IND	25.4
LFSCM3GA25EP1-5FF1020I ¹	-5	Organic fcBGA	1020	IND	25.4
LFSCM3GA25EP1-6FFA1020I	-6	Organic fcBGA Revision 2	1020	IND	25.4
LFSCM3GA25EP1-5FFA1020I	-5	Organic fcBGA Revision 2	1020	IND	25.4

1. Converted to organic flip-chip BGA package revision 2 per [PCN #02A-10](#).

Part Number	Grade	Package	Balls	Temp.	LUTs (K)
LFSC3GA40E-6FF1020I ¹	-6	Organic fcBGA	1020	IND	40.4
LFSC3GA40E-5FF1020I ¹	-5	Organic fcBGA	1020	IND	40.4
LFSC3GA40E-6FFA1020I	-6	Organic fcBGA Revision 2	1020	IND	40.4
LFSC3GA40E-5FFA1020I	-5	Organic fcBGA Revision 2	1020	IND	40.4
LFSC3GA40E-6FC1152I ²	-6	Ceramic fcBGA	1152	IND	40.4
LFSC3GA40E-5FC1152I ²	-5	Ceramic fcBGA	1152	IND	40.4
LFSC3GA40E-6FF1152I	-6	Organic fcBGA	1152	IND	40.4
LFSC3GA40E-5FF1152I	-5	Organic fcBGA	1152	IND	40.4

1. Converted to organic flip-chip BGA package revision 2 per [PCN #02A-10](#).

2. Converted to organic flip-chip BGA package per [PCN #01A-10](#).

Industrial, Cont.

Part Number	Grade	Package	Balls	Temp.	LUTs (K)
LFSCM3GA40EP1-6FF1020I ¹	-6	Organic fcBGA	1020	IND	40.4
LFSCM3GA40EP1-5FF1020I ¹	-5	Organic fcBGA	1020	IND	40.4
LFSCM3GA40EP1-6FFA1020I	-6	Organic fcBGA Revision 2	1020	IND	40.4
LFSCM3GA40EP1-5FFA1020I	-5	Organic fcBGA Revision 2	1020	IND	40.4
LFSCM3GA40EP1-6FC1152I ²	-6	Ceramic fcBGA	1152	IND	40.4
LFSCM3GA40EP1-5FC1152I ²	-5	Ceramic fcBGA	1152	IND	40.4
LFSCM3GA40EP1-6FF1152I	-6	Organic fcBGA	1152	IND	40.4
LFSCM3GA40EP1-5FF1152I	-5	Organic fcBGA	1152	IND	40.4

1. Converted to organic flip-chip BGA package revision 2 per [PCN #02A-10](#).

2. Converted to organic flip-chip BGA package per [PCN #01A-10](#).

Part Number	Grade	Package	Balls	Temp.	LUTs (K)
LFSC3GA80E-6FC1152I ¹	-6	Ceramic fcBGA	1152	IND	80.1
LFSC3GA80E-5FC1152I ¹	-5	Ceramic fcBGA	1152	IND	80.1
LFSC3GA80E-6FF1152I	-6	Organic fcBGA	1152	IND	80.1
LFSC3GA80E-5FF1152I	-5	Organic fcBGA	1152	IND	80.1
LFSC3GA80E-6FC1704I ¹	-6	Ceramic fcBGA	1704	IND	80.1
LFSC3GA80E-5FC1704I ¹	-5	Ceramic fcBGA	1704	IND	80.1
LFSC3GA80E-6FF1704I	-6	Organic fcBGA	1704	IND	80.1
LFSC3GA80E-5FF1704I	-5	Organic fcBGA	1704	IND	80.1

1. Converted to organic flip-chip BGA package per [PCN #01A-10](#).

Part Number	Grade	Package	Balls	Temp.	LUTs (K)
LFSCM3GA80EP1-6FC1152I ¹	-6	Ceramic fcBGA	1152	IND	80.1
LFSCM3GA80EP1-5FC1152I ¹	-5	Ceramic fcBGA	1152	IND	80.1
LFSCM3GA80EP1-6FF1152I	-6	Organic fcBGA	1152	IND	80.1
LFSCM3GA80EP1-5FF1152I	-5	Organic fcBGA	1152	IND	80.1
LFSCM3GA80EP1-6FC1704I ¹	-6	Ceramic fcBGA	1704	IND	80.1
LFSCM3GA80EP1-5FC1704I ¹	-5	Ceramic fcBGA	1704	IND	80.1
LFSCM3GA80EP1-6FF1704I	-6	Organic fcBGA	1704	IND	80.1
LFSCM3GA80EP1-5FF1704I	-5	Organic fcBGA	1704	IND	80.1

1. Converted to organic flip-chip BGA package per [PCN #01A-10](#).

Industrial, Cont.

Part Number	Grade	Package	Balls	Temp.	LUTs (K)
LFSC3GA115E-6FC1152I ¹	-6	Ceramic fcBGA	1152	IND	115.2
LFSC3GA115E-5FC1152I ¹	-5	Ceramic fcBGA	1152	IND	115.2
LFSC3GA115E-6FF1152I	-6	Organic fcBGA	1152	IND	115.2
LFSC3GA115E-5FF1152I	-5	Organic fcBGA	1152	IND	115.2
LFSC3GA115E-6FC1704I ¹	-6	Ceramic fcBGA	1704	IND	115.2
LFSC3GA115E-5FC1704I ¹	-5	Ceramic fcBGA	1704	IND	115.2
LFSC3GA115E-6FF1704I	-6	Organic fcBGA	1704	IND	115.2
LFSC3GA115E-5FF1704I	-5	Organic fcBGA	1704	IND	115.2

1. Converted to organic flip-chip BGA package per [PCN #01A-10](#).

Part Number	Grade	Package	Balls	Temp.	LUTs (K)
LFSCM3GA115EP1-6FC1152I ¹	-6	Ceramic fcBGA	1152	IND	115.2
LFSCM3GA115EP1-5FC1152I ¹	-5	Ceramic fcBGA	1152	IND	115.2
LFSCM3GA115EP1-6FF1152I	-6	Organic fcBGA	1152	IND	115.2
LFSCM3GA115EP1-5FF1152I	-5	Organic fcBGA	1152	IND	115.2
LFSCM3GA115EP1-6FC1704I ¹	-6	Ceramic fcBGA	1704	IND	115.2
LFSCM3GA115EP1-5FC1704I ¹	-5	Ceramic fcBGA	1704	IND	115.2
LFSCM3GA115EP1-6FF1704I	-6	Organic fcBGA	1704	IND	115.2
LFSCM3GA115EP1-5FF1704I	-5	Organic fcBGA	1704	IND	115.2

1. Converted to organic flip-chip BGA package per [PCN #01A-10](#).

Lead-Free Packaging**Commercial**

Part Number	Grade	Package	Balls	Temp.	LUTs (K)
LFSC3GA15E-7FN256C	-7	Lead-Free fpBGA	256	COM	15.2
LFSC3GA15E-6FN256C	-6	Lead-Free fpBGA	256	COM	15.2
LFSC3GA15E-5FN256C	-5	Lead-Free fpBGA	256	COM	15.2
LFSC3GA15E-7FN900C	-7	Lead-Free fpBGA	900	COM	15.2
LFSC3GA15E-6FN900C	-6	Lead-Free fpBGA	900	COM	15.2
LFSC3GA15E-5FN900C	-5	Lead-Free fpBGA	900	COM	15.2

Part Number	Grade	Package	Balls	Temp.	LUTs (K)
LFSCM3GA15EP1-7FN256C	-7	Lead-Free fpBGA	256	COM	15.2
LFSCM3GA15EP1-6FN256C	-6	Lead-Free fpBGA	256	COM	15.2
LFSCM3GA15EP1-5FN256C	-5	Lead-Free fpBGA	256	COM	15.2
LFSCM3GA15EP1-7FN900C	-7	Lead-Free fpBGA	900	COM	15.2
LFSCM3GA15EP1-6FN900C	-6	Lead-Free fpBGA	900	COM	15.2
LFSCM3GA15EP1-5FN900C	-5	Lead-Free fpBGA	900	COM	15.2

Part Number	Grade	Package	Balls	Temp.	LUTs (K)
LFSC3GA25E-7FN900C	-7	Lead-Free fpBGA	900	COM	25.4
LFSC3GA25E-6FN900C	-6	Lead-Free fpBGA	900	COM	25.4
LFSC3GA25E-5FN900C	-5	Lead-Free fpBGA	900	COM	25.4
LFSC3GA25E-7FFN1020C ¹	-7	Lead-Free Organic fcBGA	1020	COM	25.4
LFSC3GA25E-6FFN1020C ¹	-6	Lead-Free Organic fcBGA	1020	COM	25.4
LFSC3GA25E-5FFN1020C ¹	-5	Lead-Free Organic fcBGA	1020	COM	25.4
LFSC3GA25E-7FFAN1020C	-7	Lead-Free Organic fcBGA Revision 2	1020	COM	25.4
LFSC3GA25E-6FFAN1020C	-6	Lead-Free Organic fcBGA Revision 2	1020	COM	25.4
LFSC3GA25E-5FFAN1020C	-5	Lead-Free Organic fcBGA Revision 2	1020	COM	25.4

1. Converted to organic flip-chip BGA package revision 2 per [PCN #02A-10](#).

Part Number	Grade	Package	Balls	Temp.	LUTs (K)
LFSCM3GA25EP1-7FN900C	-7	Lead-Free fpBGA	900	COM	25.4
LFSCM3GA25EP1-6FN900C	-6	Lead-Free fpBGA	900	COM	25.4
LFSCM3GA25EP1-5FN900C	-5	Lead-Free fpBGA	900	COM	25.4
LFSCM3GA25EP1-7FFN1020C ¹	-7	Lead-Free Organic fcBGA	1020	COM	25.4
LFSCM3GA25EP1-6FFN1020C ¹	-6	Lead-Free Organic fcBGA	1020	COM	25.4
LFSCM3GA25EP1-5FFN1020C ¹	-5	Lead-Free Organic fcBGA	1020	COM	25.4
LFSCM3GA25EP1-7FFAN1020C	-7	Lead-Free Organic fcBGA Revision 2	1020	COM	25.4
LFSCM3GA25EP1-6FFAN1020C	-6	Lead-Free Organic fcBGA Revision 2	1020	COM	25.4
LFSCM3GA25EP1-5FFAN1020C	-5	Lead-Free Organic fcBGA Revision 2	1020	COM	25.4

1. Converted to organic flip-chip BGA package revision 2 per [PCN #02A-10](#).

Commercial, Cont.

Part Number	Grade	Package	Balls	Temp.	LUTs (K)
LFSC3GA40E-7FFN1020C ¹	-7	Lead-Free Organic fcBGA	1020	COM	40.4
LFSC3GA40E-6FFN1020C ¹	-6	Lead-Free Organic fcBGA	1020	COM	40.4
LFSC3GA40E-5FFN1020C ¹	-5	Lead-Free Organic fcBGA	1020	COM	40.4
LFSC3GA40E-7FFAN1020C	-7	Lead-Free Organic fcBGA Revision 2	1020	COM	40.4
LFSC3GA40E-6FFAN1020C	-6	Lead-Free Organic fcBGA Revision 2	1020	COM	40.4
LFSC3GA40E-5FFAN1020C	-5	Lead-Free Organic fcBGA Revision 2	1020	COM	40.4
LFSC3GA40E-7FCN1152C ²	-7	Lead-Free Ceramic fcBGA	1152	COM	40.4
LFSC3GA40E-6FCN1152C ²	-6	Lead-Free Ceramic fcBGA	1152	COM	40.4
LFSC3GA40E-5FCN1152C ²	-5	Lead-Free Ceramic fcBGA	1152	COM	40.4
LFSC3GA40E-7FFN1152C	-7	Lead-Free Organic fcBGA	1152	COM	40.4
LFSC3GA40E-6FFN1152C	-6	Lead-Free Organic fcBGA	1152	COM	40.4
LFSC3GA40E-5FFN1152C	-5	Lead-Free Organic fcBGA	1152	COM	40.4

1. Converted to organic flip-chip BGA package revision 2 per [PCN #02A-10](#).

2. Converted to organic flip-chip BGA package per [PCN #01A-10](#).

Part Number	Grade	Package	Balls	Temp.	LUTs (K)
LFSCM3GA40EP1-7FFN1020C ¹	-7	Organic fcBGA	1020	COM	40.4
LFSCM3GA40EP1-6FFN1020C ¹	-6	Organic fcBGA	1020	COM	40.4
LFSCM3GA40EP1-5FFN1020C ¹	-5	Organic fcBGA	1020	COM	40.4
LFSCM3GA40EP1-7FFAN1020C	-7	Organic fcBGA Revision 2	1020	COM	40.4
LFSCM3GA40EP1-6FFAN1020C	-6	Organic fcBGA Revision 2	1020	COM	40.4
LFSCM3GA40EP1-5FFAN1020C	-5	Organic fcBGA Revision 2	1020	COM	40.4
LFSCM3GA40EP1-7FCN1152C ²	-7	Ceramic fcBGA	1152	COM	40.4
LFSCM3GA40EP1-6FCN1152C ²	-6	Ceramic fcBGA	1152	COM	40.4
LFSCM3GA40EP1-5FCN1152C ²	-5	Ceramic fcBGA	1152	COM	40.4
LFSCM3GA40EP1-7FFN1152C	-7	Organic fcBGA	1152	COM	40.4
LFSCM3GA40EP1-6FFN1152C	-6	Organic fcBGA	1152	COM	40.4
LFSCM3GA40EP1-5FFN1152C	-5	Organic fcBGA	1152	COM	40.4

1. Converted to organic flip-chip BGA package revision 2 per [PCN #02A-10](#).

2. Converted to organic flip-chip BGA package per [PCN #01A-10](#).

Commercial, Cont.

Part Number	Grade	Package	Balls	Temp.	LUTs (K)
LFSC3GA80E-7FCN1152C ¹	-7	Lead-Free Ceramic fcBGA	1152	COM	80.1
LFSC3GA80E-6FCN1152C ¹	-6	Lead-Free Ceramic fcBGA	1152	COM	80.1
LFSC3GA80E-5FCN1152C ¹	-5	Lead-Free Ceramic fcBGA	1152	COM	80.1
LFSC3GA80E-7FFN1152C	-7	Lead-Free Organic fcBGA	1152	COM	80.1
LFSC3GA80E-6FFN1152C	-6	Lead-Free Organic fcBGA	1152	COM	80.1
LFSC3GA80E-5FFN1152C	-5	Lead-Free Organic fcBGA	1152	COM	80.1
LFSC3GA80E-7FCN1704C ¹	-7	Lead-Free Ceramic fcBGA	1704	COM	80.1
LFSC3GA80E-6FCN1704C ¹	-6	Lead-Free Ceramic fcBGA	1704	COM	80.1
LFSC3GA80E-5FCN1704C ¹	-5	Lead-Free Ceramic fcBGA	1704	COM	80.1
LFSC3GA80E-7FFN1704C	-7	Lead-Free Organic fcBGA	1704	COM	80.1
LFSC3GA80E-6FFN1704C	-6	Lead-Free Organic fcBGA	1704	COM	80.1
LFSC3GA80E-5FFN1704C	-5	Lead-Free Organic fcBGA	1704	COM	80.1

1. Converted to organic flip-chip BGA package per [PCN #01A-10](#).

Part Number	Grade	Package	Balls	Temp.	LUTs (K)
LFSCM3GA80EP1-7FCN1152C ¹	-7	Lead-Free Ceramic fcBGA	1152	COM	80.1
LFSCM3GA80EP1-6FCN1152C ¹	-6	Lead-Free Ceramic fcBGA	1152	COM	80.1
LFSCM3GA80EP1-5FCN1152C ¹	-5	Lead-Free Ceramic fcBGA	1152	COM	80.1
LFSCM3GA80EP1-7FFN1152C	-7	Lead-Free Organic fcBGA	1152	COM	80.1
LFSCM3GA80EP1-6FFN1152C	-6	Lead-Free Organic fcBGA	1152	COM	80.1
LFSCM3GA80EP1-5FFN1152C	-5	Lead-Free Organic fcBGA	1152	COM	80.1
LFSCM3GA80EP1-7FCN1704C ¹	-7	Lead-Free Ceramic fcBGA	1704	COM	80.1
LFSCM3GA80EP1-6FCN1704C ¹	-6	Lead-Free Ceramic fcBGA	1704	COM	80.1
LFSCM3GA80EP1-5FCN1704C ¹	-5	Lead-Free Ceramic fcBGA	1704	COM	80.1
LFSCM3GA80EP1-7FFN1704C	-7	Lead-Free Organic fcBGA	1704	COM	80.1
LFSCM3GA80EP1-6FFN1704C	-6	Lead-Free Organic fcBGA	1704	COM	80.1
LFSCM3GA80EP1-5FFN1704C	-5	Lead-Free Organic fcBGA	1704	COM	80.1

1. Converted to organic flip-chip BGA package per [PCN #01A-10](#).

Part Number	Grade	Package	Balls	Temp.	LUTs (K)
LFSC3GA115E-6FCN1152C ¹	-6	Lead-Free Ceramic fcBGA	1152	COM	115.2
LFSC3GA115E-5FCN1152C ¹	-5	Lead-Free Ceramic fcBGA	1152	COM	115.2
LFSC3GA115E-6FFN1152C	-6	Lead-Free Organic fcBGA	1152	COM	115.2
LFSC3GA115E-5FFN1152C	-5	Lead-Free Organic fcBGA	1152	COM	115.2
LFSC3GA115E-6FCN1704C ¹	-6	Lead-Free Ceramic fcBGA	1704	COM	115.2
LFSC3GA115E-5FCN1704C ¹	-5	Lead-Free Ceramic fcBGA	1704	COM	115.2
LFSC3GA115E-6FFN1704C	-6	Lead-Free Organic fcBGA	1704	COM	115.2
LFSC3GA115E-5FFN1704C	-5	Lead-Free Organic fcBGA	1704	COM	115.2

1. Converted to organic flip-chip BGA package per [PCN #01A-10](#).

Commercial, Cont.

Part Number	Grade	Package	Balls	Temp.	LUTs (K)
LFSCM3GA115EP1-6FCN1152C ¹	-6	Lead-Free Ceramic fcBGA	1152	COM	115.2
LFSCM3GA115EP1-5FCN1152C ¹	-5	Lead-Free Ceramic fcBGA	1152	COM	115.2
LFSCM3GA115EP1-6FFN1152C	-6	Lead-Free Organic fcBGA	1152	COM	115.2
LFSCM3GA115EP1-5FFN1152C	-5	Lead-Free Organic fcBGA	1152	COM	115.2
LFSCM3GA115EP1-6FCN1704C ¹	-6	Lead-Free Ceramic fcBGA	1704	COM	115.2
LFSCM3GA115EP1-5FCN1704C ¹	-5	Lead-Free Ceramic fcBGA	1704	COM	115.2
LFSCM3GA115EP1-6FFN1704C	-6	Lead-Free Organic fcBGA	1704	COM	115.2
LFSCM3GA115EP1-5FFN1704C	-5	Lead-Free Organic fcBGA	1704	COM	115.2

1. Converted to organic flip-chip BGA package per [PCN #01A-10](#).

Industrial

Part Number	Grade	Package	Balls	Temp.	LUTs (K)
LFSC3GA15E-6FN256I	-6	Lead-Free fpBGA	256	IND	15.2
LFSC3GA15E-5FN256I	-5	Lead-Free fpBGA	256	IND	15.2
LFSC3GA15E-6FN900I	-6	Lead-Free fpBGA	900	IND	15.2
LFSC3GA15E-5FN900I	-5	Lead-Free fpBGA	900	IND	15.2

Part Number	Grade	Package	Balls	Temp.	LUTs (K)
LFSCM3GA15EP1-6FN256I	-6	Lead-Free fpBGA	256	IND	15.2
LFSCM3GA15EP1-5FN256I	-5	Lead-Free fpBGA	256	IND	15.2
LFSCM3GA15EP1-6FN900I	-6	Lead-Free fpBGA	900	IND	15.2
LFSCM3GA15EP1-5FN900I	-5	Lead-Free fpBGA	900	IND	15.2

Part Number	Grade	Package	Balls	Temp.	LUTs (K)
LFSC3GA25E-6FN900I	-6	Lead-Free fpBGA	900	IND	25.4
LFSC3GA25E-5FN900I	-5	Lead-Free fpBGA	900	IND	25.4
LFSC3GA25E-6FFN1020I ¹	-6	Lead-Free Organic fcBGA	1020	IND	25.4
LFSC3GA25E-5FFN1020I ¹	-5	Lead-Free Organic fcBGA	1020	IND	25.4
LFSC3GA25E-6FFAN1020I	-6	Lead-Free Organic fcBGA Revision 2	1020	IND	25.4
LFSC3GA25E-5FFAN1020I	-5	Lead-Free Organic fcBGA Revision 2	1020	IND	25.4

1. Converted to organic flip-chip BGA package revision 2 per [PCN #02A-10](#).

Part Number	Grade	Package	Balls	Temp.	LUTs (K)
LFSCM3GA25EP1-6FN900I	-6	Lead-Free fpBGA	900	IND	25.4
LFSCM3GA25EP1-5FN900I	-5	Lead-Free fpBGA	900	IND	25.4
LFSCM3GA25EP1-6FFN1020I ¹	-6	Lead-Free Organic fcBGA	1020	IND	25.4
LFSCM3GA25EP1-5FFN1020I ¹	-5	Lead-Free Organic fcBGA	1020	IND	25.4
LFSCM3GA25EP1-6FFAN1020I	-6	Lead-Free Organic fcBGA Revision 2	1020	IND	25.4
LFSCM3GA25EP1-5FFAN1020I	-5	Lead-Free Organic fcBGA Revision 2	1020	IND	25.4

1. Converted to organic flip-chip BGA package revision 2 per [PCN #02A-10](#).

Part Number	Grade	Package	Balls	Temp.	LUTs (K)
LFSC3GA40E-6FFN1020I ¹	-6	Lead-Free Organic fcBGA	1020	IND	40.4
LFSC3GA40E-5FFN1020I ¹	-5	Lead-Free Organic fcBGA	1020	IND	40.4
LFSC3GA40E-6FFAN1020I	-6	Lead-Free Organic fcBGA Revision 2	1020	IND	40.4
LFSC3GA40E-5FFAN1020I	-5	Lead-Free Organic fcBGA Revision 2	1020	IND	40.4
LFSC3GA40E-6FCN1152I ²	-6	Lead-Free Ceramic fcBGA	1152	IND	40.4
LFSC3GA40E-5FCN1152I ²	-5	Lead-Free Ceramic fcBGA	1152	IND	40.4
LFSC3GA40E-6FFN1152I	-6	Lead-Free Organic fcBGA	1152	IND	40.4
LFSC3GA40E-5FFN1152I	-5	Lead-Free Organic fcBGA	1152	IND	40.4

1. Converted to organic flip-chip BGA package revision 2 per [PCN #02A-10](#).

2. Converted to organic flip-chip BGA package per [PCN #01A-10](#).

Industrial, Cont.

Part Number	Grade	Package	Balls	Temp.	LUTs (K)
LFSCM3GA40EP1-6FFN1020I ¹	-6	Lead-Free Organic fcBGA	1020	IND	40.4
LFSCM3GA40EP1-5FFN1020I ¹	-5	Lead-Free Organic fcBGA	1020	IND	40.4
LFSCM3GA40EP1-6FFAN1020I	-6	Lead-Free Organic fcBGA Revision 2	1020	IND	40.4
LFSCM3GA40EP1-5FFAN1020I	-5	Lead-Free Organic fcBGA Revision 2	1020	IND	40.4
LFSCM3GA40EP1-6FCN1152I ²	-6	Lead-Free Ceramic fcBGA	1152	IND	40.4
LFSCM3GA40EP1-5FCN1152I ²	-5	Lead-Free Ceramic fcBGA	1152	IND	40.4
LFSCM3GA40EP1-6FFN1152I	-6	Lead-Free Organic fcBGA	1152	IND	40.4
LFSCM3GA40EP1-5FFN1152I	-5	Lead-Free Organic fcBGA	1152	IND	40.4

1. Converted to organic flip-chip BGA package revision 2 per [PCN #02A-10](#).

2. Converted to organic flip-chip BGA package per [PCN #01A-10](#).

Part Number	Grade	Package	Balls	Temp.	LUTs (K)
LFSC3GA80E-6FCN1152I ¹	-6	Lead-Free Ceramic fcBGA	1152	IND	80.1
LFSC3GA80E-5FCN1152I ¹	-5	Lead-Free Ceramic fcBGA	1152	IND	80.1
LFSC3GA80E-6FFN1152I	-6	Lead-Free Organic fcBGA	1152	IND	80.1
LFSC3GA80E-5FFN1152I	-5	Lead-Free Organic fcBGA	1152	IND	80.1
LFSC3GA80E-6FCN1704I ¹	-6	Lead-Free Ceramic fcBGA	1704	IND	80.1
LFSC3GA80E-5FCN1704I ¹	-5	Lead-Free Ceramic fcBGA	1704	IND	80.1
LFSC3GA80E-6FFN1704I	-6	Lead-Free Organic fcBGA	1704	IND	80.1
LFSC3GA80E-5FFN1704I	-5	Lead-Free Organic fcBGA	1704	IND	80.1

1. Converted to organic flip-chip BGA package per [PCN #01A-10](#).

Part Number	Grade	Package	Balls	Temp.	LUTs (K)
LFSCM3GA80EP1-6FCN1152I ¹	-6	Lead-Free Ceramic fcBGA	1152	IND	80.1
LFSCM3GA80EP1-5FCN1152I ¹	-5	Lead-Free Ceramic fcBGA	1152	IND	80.1
LFSCM3GA80EP1-6FFN1152I	-6	Lead-Free Organic fcBGA	1152	IND	80.1
LFSCM3GA80EP1-5FFN1152I	-5	Lead-Free Organic fcBGA	1152	IND	80.1
LFSCM3GA80EP1-6FCN1704I ¹	-6	Lead-Free Ceramic fcBGA	1704	IND	80.1
LFSCM3GA80EP1-5FCN1704I ¹	-5	Lead-Free Ceramic fcBGA	1704	IND	80.1
LFSCM3GA80EP1-6FFN1704I	-6	Lead-Free Organic fcBGA	1704	IND	80.1
LFSCM3GA80EP1-5FFN1704I	-5	Lead-Free Organic fcBGA	1704	IND	80.1

1. Converted to organic flip-chip BGA package per [PCN #01A-10](#).

Industrial, Cont.

Part Number	Grade	Package	Balls	Temp.	LUTs (K)
LFSC3GA115E-6FCN1152I ¹	-6	Lead-Free Ceramic fcBGA	1152	IND	115.2
LFSC3GA115E-5FCN1152I ¹	-5	Lead-Free Ceramic fcBGA	1152	IND	115.2
LFSC3GA115E-6FFN1152I	-6	Lead-Free Organic fcBGA	1152	IND	115.2
LFSC3GA115E-5FFN1152I	-5	Lead-Free Organic fcBGA	1152	IND	115.2
LFSC3GA115E-6FCN1704I ¹	-6	Lead-Free Ceramic fcBGA	1704	IND	115.2
LFSC3GA115E-5FCN1704I ¹	-5	Lead-Free Ceramic fcBGA	1704	IND	115.2
LFSC3GA115E-6FFN1704I	-6	Lead-Free Organic fcBGA	1704	IND	115.2
LFSC3GA115E-5FFN1704I	-5	Lead-Free Organic fcBGA	1704	IND	115.2

1. Converted to organic flip-chip BGA package per [PCN #01A-10](#).

Part Number	Grade	Package	Balls	Temp.	LUTs (K)
LFSCM3GA115EP1-6FCN1152I ¹	-6	Lead-Free Ceramic fcBGA	1152	IND	115.2
LFSCM3GA115EP1-5FCN1152I ¹	-5	Lead-Free Ceramic fcBGA	1152	IND	115.2
LFSCM3GA115EP1-6FFN1152I	-6	Lead-Free Organic fcBGA	1152	IND	115.2
LFSCM3GA115EP1-5FFN1152I	-5	Lead-Free Organic fcBGA	1152	IND	115.2
LFSCM3GA115EP1-6FCN1704I ¹	-6	Lead-Free Ceramic fcBGA	1704	IND	115.2
LFSCM3GA115EP1-5FCN1704I ¹	-5	Lead-Free Ceramic fcBGA	1704	IND	115.2
LFSCM3GA115EP1-6FFN1704I	-6	Lead-Free Organic fcBGA	1704	IND	115.2
LFSCM3GA115EP1-5FFN1704I	-5	Lead-Free Organic fcBGA	1704	IND	115.2

1. Converted to organic flip-chip BGA package per [PCN #01A-10](#).

For Further Information

For further information about the flexiPCS, see the [LatticeSC/M Family flexiPCS Data Sheet](#).

A variety of technical notes for the LatticeSC/M family are also available on the Lattice Semiconductor website at www.latticesemi.com.

- [LatticeSC PURESPEED I/O Usage Guide](#) (TN1088)
- [LatticeSC PURESPEED I/O Adaptive Input Logic User's Guide](#) (TN1158)
- [LatticeSC sysCLOCK PLL/DLL User's Guide](#) (TN1098)
- [On-Chip Memory Usage Guide for LatticeSC Devices](#) (TN1094)
- [LatticeSC/M DDR/DDR2 SDRAM Memory Interface User's Guide](#) (TN1099)
- [LatticeSC QDRII/II+ SRAM Memory Interface User's Guide](#) (TN1096)
- [LatticeSC sysCONFIG Usage Guide](#) (TN1080)
- [LatticeSC MPI/System Bus](#) (TN1085)
- [SPI Serial Flash Programming Using ispJTAG in LatticeSC Devices](#) (TN1100)
- [Power Estimation and Management for LatticeSC Devices](#) (TN1101)
- [LatticeSC SERDES Jitter](#) (TN1084)
- [LatticeSC FPGAs: Implementing 3.3V Interfaces in 2.5V VCCIO Banks](#) (TN1110)
- [Lattice PCI Express Basic Demo User's Guide](#) (UG08)
- [LatticeSC flexiPCS/SERDES Design Guide](#) (TN1145)
- [Temperature Sensing Diode in LatticeSC Devices](#) (TN1115)
- [SPI4.2 Interoperability Between ORSPI4 and LatticeSC Devices](#) (TN1116)

For further information on Interface standards refer to the following websites:

- JEDEC Standards (LVTTTL, LVCMOS, SSTL, HSTL): www.jedec.org
- Optical Interface (SPI-4.2, XSBI, CSIX and XGMII): www.oiforum.com
- RAPIDIO: www.rapidio.org
- PCI/PCIX: www.pcisig.com

Date	Version	Section	Change Summary
February 2006	01.0	—	Initial release.
March 2006	01.1	Introduction	SC25 1020 I/O count changed to 476.
		Architecture	Changed ROM 16X4 to ROM 16X2.
			Changed “X2 or X4” to “DIV2 or DIV4”.
			Added Global Set/Reset Section.
		DC and Switching Characteristics	Added notes 5 and 6 to Recommended Operating Conditions table.
			Added Power Supply Ramp Rates table.
			Removed -5 and -6 speed grades from Typical Building Block Performance table.
			Added Input Delay Timing table.
		Pinout Information	Added Synchronous GSR Timing table.
			Expanded PROBE_VCC and PROBE_GND description.
			Removed A-RXREFCLKP_[L/R] from Signal Description table.
			Added RESP_[ULC/URC] to Signal Description table.
			Added notes 1 and 2 to Signal Description table.
			Changed number of NCs to 28.
			Changed number of SERDES (signal + power supply) to 74.
Removed RESP balls from NC list (B2, C2, B29, C29).			
Added note to VTT table.			
Changed RxRefclk (B2 and C2) to NC.			
Added RESP_ULC.			
Added RESP_URC.			
Changed RxRefclk (B29 and C29) to NC.			
June 2006	01.2	Introduction	Changed SERDES min bandwidth from 622 Mbps to 600 Mbps.
			Changed max SERDES bandwidth from 3.4 Gbps to 3.8 Gbps.
			Corrected number of package I/Os for the SC80 and SC115 1704 pin packages.
			Updated speed performance for typical functions with ispLEVER 6.0 values.
		Architecture	Changed “When these pins are not used they should be left unconnected.” with “Unused VTT pins should be connected to GND if the internal or external VCMT function is not used in the bank. If the internal or external VCMT function for differential input termination is used, the VTT pins should be unconnected and allowed to float.”
			Added “SERDES Power Supply Sequencing Requirements” section.
			Changed total bandwidth per quad from 13.6 Gbps to 15.2 Gbps.
			Added the accuracy of the temperature-sensing diode to be typically +/- 10 °C. Also referred to a temperature-sensing diode application note for more information.
		DC and Switching Characteristics	Changed “CTAP” to “internal or external VCMT”.
			Changed VCC12 parameter to include VDDP, VDDTX and VDDR. X.
			Changed typical values to match ispLEVER 6.0 Power Calculator.

© 2011 Lattice Semiconductor Corp. All Lattice trademarks, registered trademarks, patents, and disclaimers are as listed at www.latticesemi.com/legal. All other brand or product names are trademarks or registered trademarks of their respective holders. The specifications and information herein are subject to change without notice.

Date	Version	Section	Change Summary
June 2006 (cont.)	01.2 (cont.)	DC and Switching Characteristics (cont.)	Updated Typical Building Block Performance with ispLEVER 6.0 values.
			Updated LatticeSC External Switching Characteristics with ispLEVER 6.0 values.
			Updated Lattice SC Internal Timing Parameters with ispLEVER 6.0 values.
			Updated Lattice SC Family Timing Adders with ispLEVER 6.0 values
			Changed % spread from 1 to 0.5 min and from 3 to 1.5 max.
			Changed conditions to refer to “with multiplication” and “without multiplication”.
			Changed the formula for t_{OPJIT} with multiplication (same result, different representation).
		Pinout Information	Expanded definition of NC.
			Expanded definition of GND.
			Expanded definition of VTT_x.
			Expanded definition of VCC12.
			Added accuracy of TEMP pin.
			Added RESPN_[ULC/URC].
			Updated Pin Information Summary with additional devices and packages.
			Added additional devices and packages pinouts.
			Removed Power Supply and NC connections table
			Removed VTT table
Ordering Information	Removed LFSC25 Logic Signal Connections: 900-Ball fBGA1 table		
	Changed all VDDP, VDDTX and VDDR _X to VCC12.		
August 2006	01.3	Introduction	Added SC40 1152 information to Table 1-1.
			Updated Table 1-3 with ispLEVER 6.0 SP1 results.
		Architecture	Added SSTL18 II to Table 2-8.
			Changed Table 2-10 VCCIO column to “N/A” for LVDS, mini-LVDS, BLVDS25, MLVDS25, HYPT and RSDS.
			Changed Hypertransport performance to 700 MHz (1400 Mbps) in Table 2-11.
			Changed SPI4.2 performance to 500 MHz (1000 Mbps) in Table 2-11
			Added “On packages that include PROBE_GND, the most accurate measurements will occur between the TEMP pin and the PROBE_GND pin. On packages that do not include PROBE_GND, measurements should be made between the TEMP pin and board ground.”
		DC and Switching Characteristics	Added VCCIO of 2.5 V for LVPECL33 in table 2-9.
			Updated Typical Building Block Performance with ispLEVER 6.0 SP1 results.
			Updated Initialization and Standby Supply Current table to break out ICC and ICC12.
			Updated LatticeSC External Switching Characteristics with ispLEVER 6.0 SP1 results.

Date	Version	Section	Change Summary
August 2006 (cont.)	01.3 (cont.)	DC and Switching Characteristics (cont.)	Updated LatticeSC Family Timing Adders with ispLEVER 6.0 SP1 results
			Updated PLL Timing Parameters based on PDE testing results
			Removed RDDATA parameter from sysCONFIG readback timing table
		Multiple	Changed TDO/RDDATA to TDO
		Pinout Information	Removed all MPI signals from SC15 256 pin package Dual Function Column
			Added note to SC15, SC25 900 pin package that the package supports a 16 bit MPI
			Added note that pin D3 in an SC15 and SC25 900 pin package should not be used for single-ended outputs
			Added note that pin D28 in an SC15 and SC25 900 pin package should not be used for single-ended outputs
			Added note to SC25 1020 pin package that the package supports a 16 bit MPI
			Added note to SC80 1152 pin package that the package supports a 32 bit MPI
Added note to SC80 1704 pin package that the package supports a 32 bit MPI			
Ordering Information	Changed "fcBGA" for the 1020 packages to "ffBGA"		
November 2006	01.4	Introduction	LatticeSC Family Selection Guide table – I/O count for SC80 device, 1704 fcBGA package changed to 904/32. I/O count for SC115 device, 1704 fcBGA package changed to 942/32.
		DC and Switching Characteristics	DC Electrical Characteristics table – Updated the initialization and standby supply current values.
			DC Electrical Characteristics table – Updated the sysCONFIG Master Parallel mode RCLK low and RCLK high time specifications.
			DC Electrical Characteristics table – Updated VCCIO values for LVPECL33 I/Os.
		Pin Information	Pin Information Summary table - Changed number of single ended user I/Os from 906 to 904 for 1704 fcBGA.
			Removed the single-ended only output restriction on pins D3 and D28 in an SC15 and SC25 900 pin package.
		Ordering Information	Ordering Information tables - Changed number of I/Os from 906 to 904 for 1704 fcBGA.
			Added ordering part numbers for LatticeSC/SCM 40K and 115K LUT devices.
			Added lead-free ordering part numbers.
		Multiple	Changed number of available SC80 I/O from 906 to 904.
Changed number of available SC115 I/O from 944 to 942.			
January 2007	01.4a	Architecture	Added EBR Asynchronous Reset section.
February 2007	01.4b	Architecture	Updated EBR Asynchronous Reset section.
March 2007	01.5	Architecture	Added EBR asynchronous reset clarification
			Clarified that differential drivers are not supported in banks 1, 4 and 5
		DC and Switching Characteristics	Added clarification for the description of the junction temperature specification in the Absolute Maximum Ratings section.
			Updated Initialization and Standby Current table.
			Updated LatticeSC External Switching Characteristics with ispLEVER 6.1 SP1 results.

Date	Version	Section	Change Summary
March 2007 (cont.)	01.5 (cont.)	DC and Switching Characteristics (cont.)	Updated LatticeSC Internal Timing Parameters with ispLEVER 6.1 SP1 results.
			Updated t_{FDEL} and t_{CDEL} specifications.
			Updated LatticeSC Family Timing Adders with ispLEVER 6.1 SP1 results.
			Updated PLL specifications to expand frequency range down to 2 MHz and break out jitter for the different ranges.
			Added footnote to sysCLOCK PLL Timing table specifying the conditions for the jitter measurements.
			Added t_{DLL} specification to sysCLOCK DLL Timing table.
			Added footnote to sysCLOCK DLL Timing table specifying the conditions for the jitter measurements.
			Added sysCONFIG Master Parallel Configuration Mode and sysCONFIG SPI Port to LatticeSC sysCONFIG Port Timing table.
		Pin Information	Updated Pin Information Summary with SC40 information.
			Updated LFSC25 Logic Signal Connections: FF1020 with SC40 information.
Updated LFSC80 Logic Signal Connections: FC1152 with SC40 information.			
August 2007	01.6	General	Changed references of "HDC" to "HDC/SI".
			Changed references of "LDCN" to "LDCN/SCS".
			Changed references of "BUSYN/RCLK" to "BUSYN/RCLK/SCK".
			Changed references of "RDCFGN" to "TSALLN".
			Changed references of "TDO/RDDATA" to "TDO".
		Architecture	Updated text in Ripple Mode section.
			Added information to Global Set/Reset.
			Added information for Spread Spectrum Clocking
			Modified information for PLL/DLL Cascading. DLL to PLL is now supported.
			Modified AIL Block text and figure.
			Modified Figure 2-20 DDR/Shift Register Block.
			Added Information to Hot Socketing.
			Added new information for I/O Architecture Rules.
			Added information to SERDES Power Supply Sequencing Requirements.
		DC and Switching Characteristics	Added footnote to Hot Socketing Specifications table.
			Modified Initialization and Standby Supply Current table.
			Modified GSR Timing table.
			Modified sysCLOCK DLL Timing table to include I_{DUTY} .
			Deleted Readback Timing information from sysCONFIG Port Timing table.
			Modified data in External Switching Characteristics table.
		Pin Information	Added information to the Signal Descriptions table for HDC/SI, LDCN/SCS.
			Added footnote to Signal Descriptions table.
			Modified Description for signal BUSYN/RCLK/SCK.
			Modified data in Pin Information Summary and device-specific Pinout Information tables.

Date	Version	Section	Change Summary
September 2007	01.7	Pinout Information	Added Thermal Management text section.
		Supplemental Information	Updated title list.
November 2007	01.8	Ordering Information	Removed -7 speed grade information for 115K LUT devices in the Ordering Information tables.
January 2008	01.9	Introduction	Corrections/Additions to memory controller list (Tables 1-2).
		Architecture	AIL Overview – Modified power used by AIL block.
			PURESPEED I/O Buffer Banks – Modified VTT termination info. Added info about complimentary drivers for all banks.
			Supported Source Synchronous Interfaces – Modified data for DDRII in Table 2-11.
		DC and Switching Characteristics	Recommended Operating Conditions – Changed footnote 3.
			Initialization and Standby Supply Current – Inserted a paragraph with info regarding the table. Also updated the table.
			Typical Building Block Function Performance – Added VCC=1.2V=1.2V+/-5% above Pin to Pin Performance table.
			LatticeSC External Switching Characteristics – Added VCC=1.2V=1.2V+/-5% above table. Reworded footnote 3.
			LatticeSC Family Timing Adders – Added VCC=1.2V=1.2V+/-5% above table.
			LatticeSC Internal Timing Parameters – Added VCC=1.2V=1.2V+/-5% above table. Reworded footnote 1.
GSR Timing – Added a new table for Internal System Bus Timing after GSR Timing.			
LatticeSC sysCONFIG Port Timing – Corrected sysCONFIG SPI Port information.			
Pinout Information	Signal Descriptions – Modified info for VTT_x, PROBE_VCC, and PROBE_GND. Modified info for [LOC]_DLL[T,C]_IN[C,D,E,F].		
Supplemental Information	Updated list of technical notes, added reference to LatticeSC/M flexiPCS Data Sheet.		
March 2008	02.0	DC and Switching Characteristics	Updated Internal Timing Parameters table.
			Updated Read Mode timing diagram.
			Updated Read Mode with Input Registers Only timing diagram.
June 2008	02.1	—	Data sheet status changed from preliminary to final.
		Architecture	Removed Read-Before-Write sysMEM EBR mode.
		DC and Switching Characteristics	Updated LatticeSC/M External Switching Characteristics table.
			Updated LatticeSC/M Internal Timing Parameters table.
December 2008	02.2	Architecture	Output/Tristate DDR/Shift Register Block Diagram - corrected connection to POS.
		DC and Switching Characteristics	DC and Switching Characteristics table - updated data for t _{SUI_PIO} .
			Added T _R , T _F parameter to PURESPEED I/O Differential Electrical Characteristics (LVDS) table.
January 2010	02.3	Multiple	Removed references to HyperTransport throughout the data sheet.
		Introduction	Updated per PCN #01A-10 (ceramic fcBGA conversion to organic fcBGA for the 1152-ball and 1704-ball fcBGA packages) and PCN #02A-10 (1020-ball organic fcBGA conversion to 1020-ball organic fcBGA revision 2 package).
		Ordering Information	

Date	Version	Section	Change Summary
December 2011	02.4	DC and Switching Characteristics	Updated JTAG Port Timing Specifications table.

Компания «Океан Электроники» предлагает заключение долгосрочных отношений при поставках импортных электронных компонентов на взаимовыгодных условиях!

Наши преимущества:

- Поставка оригинальных импортных электронных компонентов напрямую с производств Америки, Европы и Азии, а так же с крупнейших складов мира;
- Широкая линейка поставок активных и пассивных импортных электронных компонентов (более 30 млн. наименований);
- Поставка сложных, дефицитных, либо снятых с производства позиций;
- Оперативные сроки поставки под заказ (от 5 рабочих дней);
- Экспресс доставка в любую точку России;
- Помощь Конструкторского Отдела и консультации квалифицированных инженеров;
- Техническая поддержка проекта, помощь в подборе аналогов, поставка прототипов;
- Поставка электронных компонентов под контролем ВП;
- Система менеджмента качества сертифицирована по Международному стандарту ISO 9001;
- При необходимости вся продукция военного и аэрокосмического назначения проходит испытания и сертификацию в лаборатории (по согласованию с заказчиком);
- Поставка специализированных компонентов военного и аэрокосмического уровня качества (Xilinx, Altera, Analog Devices, Intersil, Interpoint, Microsemi, Actel, Aeroflex, Peregrine, VPT, Syfer, Eurofarad, Texas Instruments, MS Kennedy, Miteq, Cobham, E2V, MA-COM, Hittite, Mini-Circuits, General Dynamics и др.);

Компания «Океан Электроники» является официальным дистрибьютором и эксклюзивным представителем в России одного из крупнейших производителей разъемов военного и аэрокосмического назначения «JONHON», а так же официальным дистрибьютором и эксклюзивным представителем в России производителя высокотехнологичных и надежных решений для передачи СВЧ сигналов «FORSTAR».



JONHON

«JONHON» (основан в 1970 г.)

Разъемы специального, военного и аэрокосмического назначения:

(Применяются в военной, авиационной, аэрокосмической, морской, железнодорожной, горно- и нефтедобывающей отраслях промышленности)

«FORSTAR» (основан в 1998 г.)

ВЧ соединители, коаксиальные кабели, кабельные сборки и микроволновые компоненты:

(Применяются в телекоммуникациях гражданского и специального назначения, в средствах связи, РЛС, а так же военной, авиационной и аэрокосмической отраслях промышленности).



Телефон: 8 (812) 309-75-97 (многоканальный)

Факс: 8 (812) 320-03-32

Электронная почта: ocean@oceanchips.ru

Web: <http://oceanchips.ru/>

Адрес: 198099, г. Санкт-Петербург, ул. Калинина, д. 2, корп. 4, лит. А