



General Description

Silego SLG55544 is a combination of current-limited USB port power switch with a USB 2.0 high-speed data line (D+/D-) switch and USB charging port identification circuit. Applications include notebook PCs and other intelligent USB host devices. The wide bandwidth (2.6 GHz) data-line switch also features low capacitance and low on resistance, allowing signals to pass with minimum edge and phase distortion. The SLG55544 monitors D+ and D-, providing the correct hand-shaking protocol with compliant client devices.

Features

- Meets Battery Charging Specification BC1.2 for DCP and CDP
- Meets Chinese Telecommunications Industry Standard YD/T 1591-2009
- Supports Non-BC 1.2 charging modes via Automatic selection
 - DM/DP Divider Modes 2.7V/2.0V (1A) & 2.0V/2.7V (2A)
 - DM/DP 1.2V Mode
- Support Smart-CDP function - Automatic CDP/SDP mode support for Always data Communication
- Compatible with USB 2.0/3.0 power switch requirements
- 73 mΩ (typ) high side MOSFET
- Adjustable Current Limit up to 3.0 A (typ)
- Pb-Free / RoHS Compliant
- Halogen-Free
- TQFN-16 Package / MSL-1
- UL Listed and CB File No. E468659

Pin Configuration

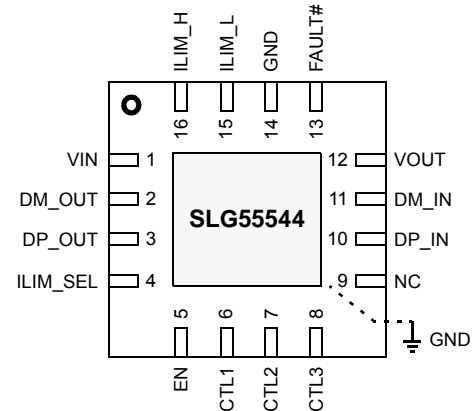

**16-pin TQFN
(Top View)**

Applications

- USB Ports/Hubs
- Notebook PCs
- Universal Wall Charging Adapter

Block Diagram

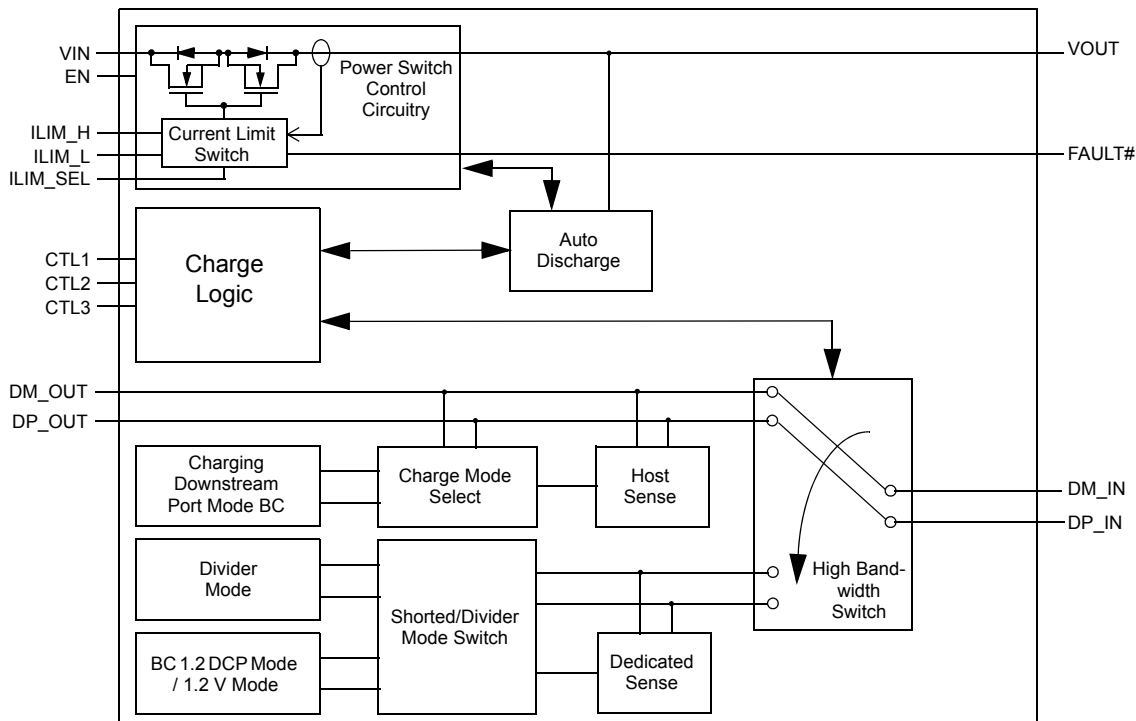



Pin Description

Pin #	Name	Type	Description
1	VIN	PWR	Input voltage, connect a 0.1 μ F or greater ceramic capacitor from IN to GND as close to the device as possible
2	DM_OUT	Input/Output	D- data line to USB host controller
3	DP_OUT	Input/Output	D+ data line to USB host controller
4	ILIM_SEL	Input	Logic level input signal used to dynamically change power switch current-limit threshold; logic LOW selects ILIM_L, logic HIGH selects ILIM_H
5	EN	Input	Logic level control input for turning the power switch and the signal switches on/off. When EN is LOW, the device is disabled, the signal and power switches are OFF.
6	CTL1	Input	Logic level control inputs for controlling the charging mode and the signal switches. The "000" configuration is used to force and discharge of the output (VOUT) capacitor.
7	CTL2	Input	
8	CTL3	Input	
9	NC	NC	No Connect. Open or connect to Ground
10	DP_IN	Input/Output	D+ data line to connector, input/output used for hand-shaking with portable equipment
11	DM_IN	Input/Output	D- data line to connector, input/output used for hand-shaking with portable equipment
12	VOUT	PWR	Power switch output
13	FAULT#	Output	Active low open drain output, asserted during over-temperature or current-limit conditions
14	GND	GND	Ground
15	ILIM_L	Input	External resistor used to set current-limit threshold when ILIM_SEL is LOW. See current limit setting in detailed description.
16	ILIM_H	Input	External resistor used to set current-limit threshold when ILIM_SEL is HIGH. See current limit setting in detailed description.
17	Thermal Pad	GND	Ground

Ordering Information

Part Number	Type
SLG55544V	TQFN-16
SLG55544VTR	TQFN-16 - Tape and Reel



Absolute Maximum Conditions ¹

Parameter		Min.	Max.	Unit
Supply Voltage range	VIN	-0.3	7	V
Input Voltage range	EN, ILIM_L, ILIM_H, ILIM_SEL, CTL1, CTL2, CTL3	-0.3	7	V
Output Voltage range	VOUT, FAULT#	-0.3	7	V
Output Voltage range	VIN to VOUT	-7	7	V
Voltage range	DP_IN, DM_IN, DP_OUT, DM_OUT	-0.3	VIN+0.3 or 5.7	V
Input Clamp current	DP_IN, DM_IN, DP_OUT, DM_OUT	--	±20	mA
Continuous current in SDP or CDP mode	DP_IN to DP_OUT or DM_IN to DM_OUT	--	±100	mA
Continuous current in BC1.2 DCP mode	DP_IN to DM_IN	--	±35	mA
Continuous output current		Internally limited		
Continuous output sink current	FAULT#, NC	--	25	mA
Continuous output source current	ILIM_L, ILIM_H	--	1	mA
Continuous total power dissipation		Internally limited		
ESD Rating, Human Body Model (HBM)	VIN, EN, ILIM_L, ILIM_H, ILIM_SEL, CTL1, CTL2, CTL3, NC, OUT, FAULT#	2	--	kV
ESD Rating, Human Body Model (HBM)	DP_IN, DM_IN, DP_OUT, DM_OUT	8	--	kV
ESD Rating, Charged Device Model		500	--	V
Operating Temperature Range		-40	85	°C
Storage Temperature Range		-65	165	°C

1. Stresses beyond those listed under "absolute maximum ratings" may cause permanent damage to the device. These are stress ratings only and functional operation of the device at these or any other conditions beyond those indicated under "recommended operating conditions" is not implied. Exposure to absolute-maximum-rated conditions for extended periods may affect device reliability.



Thermal Information¹

Parameter		RTE	Unit
θ_{JA}	Junction-to-ambient thermal resistance ²	53.4	°C/W
θ_{JCtop}	Junction-to-case (top) thermal resistance ³	51.4	°C/W
θ_{JB}	Junction-to-board thermal resistance ⁴	17.2	°C/W
ψ_{JT}	Junction-to-top characterization parameter ⁵	3.7	°C/W
ψ_{JB}	Junction-to-board characterization parameter ⁶	20.7	°C/W
θ_{JCbot}	Junction-to-case (bottom) thermal resistance ⁷	3.9	°C/W

1. For more information about traditional and new thermal metrics, see the IC Package Thermal Metrics application report, SPRA953.

2. The junction-to-ambient thermal resistance under natural convection is obtained in a simulation on a JEDEC-standard, high-K board, as specified in JESD51-7, in an environment described in JESD51-2a.

3. The junction-to-case (top) thermal resistance is obtained by simulating a cold plate test on the package top. No specific JEDEC-standard test exists, but a close description can be found in the ANSI SEMI standard G30-88.

4. The junction-to-board thermal resistance is obtained by simulating in an environment with a ring cold plate fixture to control the PCB temperature, as described in JESD51-8.

5. The junction-to-top characterization parameter, ψ_{JT} , estimates the junction temperature of a device in a real system and is extracted from the simulation data for obtaining θ_{JA} , using a procedure described in JESD51-2a (sections 6 and 7).

6. The junction-to-board characterization parameter, ψ_{JB} , estimates the junction temperature of a device in a real system and is extracted from the simulation data for obtaining θ_{JA} , using a procedure described in JESD51-2a (sections 6 and 7).

7. The junction-to-case (bottom) thermal resistance is obtained by simulating a cold plate test on the exposed (power) pad. No specific JEDEC standard test exists, but a close description can be found in the ANSI SEMI standard G30-88.

Recommended Operating Conditions

over operating free-air temperature range (unless otherwise noted)

Symbol	Parameter	Condition/Note	Min.	Typ.	Max.	Unit
V_{IN}	Input Voltage	VIN	4.5	--	5.5	V
		Logic Level Inputs (CTL1, CTL2, CTL3, EN, ILIM_SEL)	0	--	5.5	V
		Data Line Inputs (DP_IN, DM_IN, DP_OUT, DM_OUT)	--	--	5.5	V
	Continuous Current	Data Line inputs (SDP or CDP mode, DP_IN to DP_OUT or DM_IN to DM_OUT)	--	--	±30	mA
		Data Line inputs (BC1.2 DCP mode, DP_IN to DM_IN)	--	--	±15	mA
R_{ILIM}	Current-limit set resistors	ILIM_L to GND, ILIM_H to GND	16.9	--	750	k Ω
T_J	Operating virtual junction temperature		-40	--	125	°C
V_{IH}	Input Logic High		1.8	--	--	V
V_{IL}	Input Logic Low		--	--	0.8	V
V_{HYST}	Input Logic Hysteresis		--	250	--	mV



Electrical Characteristics

Conditions are $-40 \leq T_J \leq 125^\circ\text{C}$ unless otherwise noted. $V_{EN} = V_{IN} = 5\text{ V}$, $R_{FAULT\#} = 10\text{ k}\Omega$, $R_{ILIM_L} = 80\text{ k}\Omega$, $R_{ILIM_H} = 20\text{ k}\Omega$, $ILIM_SEL = V_{IN}$, $CTL1 = CTL2 = CTL3 = V_{IN}$, unless otherwise noted. Positive currents are into pins. Typical values are at 25°C . All voltages are with respect to GND unless otherwise noted.

Electrical Characteristics - Power Switch

Symbol	Parameter	Condition/Note	Min.	Typ.	Max.	Unit
$R_{ds\ ON}$	Static drain-source on-state resistance ¹	$I_{OUT} = 2\text{ A}$, $V_{ILIM_SEL} = \text{Logic High}$	--	73	--	m Ω
		$I_{OUT} = 100\text{ mA}$, $V_{ILIM_SEL} = \text{Logic Low}$	--	73	--	m Ω
		$-40^\circ\text{C} \leq T_A = T_J \leq 85^\circ\text{C}$, $I_{OUT} = 2\text{ A}$, $V_{ILIM_SEL} = \text{Logic High}$	--	73	--	m Ω
		$T_A = T_J = 25^\circ\text{C}$, $I_{OUT} = 2\text{ A}$, $V_{ILIM_SEL} = \text{Logic High}$	--	73	--	m Ω
T_R	Rise Time, Output	$C_L = 1\ \mu\text{F}$, $R_L = 100\ \Omega$,	0.7	1.0	1.6	ms
T_F	Fall Time, Output	$C_L = 1\ \mu\text{F}$, $R_L = 100\ \Omega$,	0.2	0.35	0.5	ms
R_{DIS}	Out Discharge Resistance		337	498	681	Ω
T_{DIS}	Out Discharge Hold Time		--	2	--	s
I_{REV}	Reverse leakage current	$V_{OUT} = 5.5\text{ V}$, $V_{IN} = V_{EN} = 0\text{ V}$, $T_J = 25^\circ\text{C}$	--	--	2	μA

Electrical Characteristics - Input EN

Symbol	Parameter	Condition/Note	Min.	Typ.	Max.	Unit
V_{EN}	Enable pin turn on/off threshold, falling		--	1.08	--	V
V_{EN_HYS}	EN Hysteresis		--	230 ¹	--	mV
I_{EN}	Input current	$V_{EN} = 0\text{ V}$ or 5.5 V	-0.5	--	0.5	μA
T_{ON}	Turn On time	$C_L = 1\ \mu\text{F}$, $R_L = 100\ \Omega$,	--	2.7	4.0	ms
T_{OFF}	Turn Off time	$C_L = 1\ \mu\text{F}$, $R_L = 100\ \Omega$,	--	1.7	3.0	ms

Note: 1. Typical value for reference only, not 100% tested.

Electrical Characteristics - Current Limit

Symbol	Parameter	Condition/Note	Min.	Typ.	Max.	Unit
V_{ILIM_SEL}	ILIM_SEL turn on/off threshold, falling		--	1.08	--	V
V_{ILIM_HYS}	ILIM_SEL Hysteresis		--	230 ¹	--	mV
	ILIM_SEL Input current	$V_{ILIM_HYS} = 0\text{ V}$ or 5.5 V	-0.5	--	0.5	μA

**Electrical Characteristics - Current Limit**

Symbol	Parameter	Condition/Note	Min.	Typ.	Max.	Unit
I _{SHORT}	Maximum DC Output current from VIN to VOUT	V _{ILIM_SEL} = Logic Low R _{ILIM_L} = 210kΩ	0.22	0.26	0.30	A
		V _{ILIM_SEL} = Logic Low R _{ILIM_L} = 80.6kΩ -40°C ≤ T _J ≤ 85°C	0.60	0.66	0.72	A
		V _{ILIM_SEL} = Logic Low R _{ILIM_L} = 22.1kΩ	2.120	2.275	2.430	A
		V _{ILIM_SEL} = Logic High R _{ILIM_H} = 20kΩ	2.340	2.510	2.685	A
		V _{ILIM_SEL} = Logic High R _{ILIM_H} = 16.9kΩ	2.77	2.97	3.17	A
T _{IOS}	Response time to short circuit	V _{IN} = 5 V	--	6.65 ¹	--	μs

Note: 1. Typical value for reference only, not 100% tested.

Electrical Characteristics - Supply Current

Symbol	Parameter	Condition/Note	Min.	Typ.	Max.	Unit
I _{CCL}	Supply current, switch disabled	V _{EN} = 0 V, OUT grounded, -40°C ≤ T _J ≤ 85°C	--	0.1	2	μA
I _{CCH}	Supply current, operating	V _{EN} = V _{IN}	--	215	270	μA

Electrical Characteristics - Undervoltage Lockout

Symbol	Parameter	Condition/Note	Min.	Typ.	Max.	Unit
V _{UVLO}	Low level input voltage, IN	V _{IN} rising	3.9	4.1	4.3	V
V _{IN_HYS}	Hysteresis, IN			100 ¹		mV

Note: 1. Typical value for reference only, not 100% tested.

Electrical Characteristics - FAULT#

Symbol	Parameter	Condition/Note	Min.	Typ.	Max.	Unit
V _{OL}	Output Low voltage, FAULT#	I _{FAULT#} = 1 mA	--	--	100	mV
I _{LEAK}	Off-state leakage	V _{FAULT#} = 5.5 V	--	--	1	μA
	FAULT# Deglitch	FAULT# assertion or de-assertion due to over-current condition	--	8.6	--	ms

Electrical Characteristics - CTL Inputs

Symbol	Parameter	Condition/Note	Min.	Typ.	Max.	Unit
V _{CTL}	CTL pins turn on/off threshold, falling		--	1.08	--	V
V _{CTL_HYS}	Hysteresis, CTL		--	230 ¹	--	mV
	Input current	V _{CTL} = 0 V or 5.5 V	-0.5	--	0.5	μA

Note: 1. Typical value for reference only, not 100% tested.

**Electrical Characteristics - Thermal Shutdown**

Symbol	Parameter	Condition/Note	Min.	Typ.	Max.	Unit
	Thermal shutdown threshold		155	--	--	°C
	Thermal shutdown threshold in current-limit		135	--	--	°C
	Hysteresis		20 ¹			°C

Note: 1. Typical value for reference only, not 100% tested.

Electrical Characteristics - Analog Switch

$V_{IN} = 5.0\text{ V}$, $T_A = 25\text{ °C}$ (unless specified otherwise)

Symbol	Parameter	Condition/Note	Min.	Typ.	Max.	Unit
V_{DP_IN}, V_{DM_IN}	Analog signal Range		0	--	V_{DD}	V
R_{ON}	On Resistance DP_OUT/DM_OUT Switch	$V_{DP/DM_OUT} = 0\text{ V}$, $I_{DP/DM_IN} = 30\text{ mA}$	--	2	4	Ω
		$V_{DP/DM_OUT} = 2.4\text{ V}$, $I_{DP/DM_IN} = -15\text{ mA}$	--	3	6	Ω
ΔR_{ON}	On Resistance Mismatch between channels DP_OUT/DM_OUT Switch	$V_{IN} = 5\text{ V}$ $V_{DP_IN} = V_{DM_IN} = 400\text{ mV}$ $I_{DP_IN} = I_{DM_IN} = 10\text{ mA}$	--	0.1	--	Ω
R_{FLAT}	On Resistance flatness DP_OUT/DM_OUT Switch	$V_{IN} = 5.0\text{ V}$ $V_{DP_IN} = V_{DM_IN} = 0\text{ V to } V_{IN}$ $I_{DP_IN} = I_{DM_IN} = 10\text{ mA}$	--	0.5	--	Ω
R_{SHORT}	On Resistance of DP_OUT/DM_OUT Short	$V_{CB} = 0\text{ V}$ $V_{DP_IN} = 1\text{ V}$ $I_{DP_IN} = I_{DM_IN} = 10\text{ mA}$	--	100	150	Ω
$I_{DP_OUT_OFF}, I_{DM_OUTOFF}$	Off-Leakage Current	$V_{IN} = 3.6\text{ V}$ $V_{DP_IN} = V_{DM_IN} = 0.3\text{ V to } 3.3\text{ V}$ $V_{DP_OUT} = V_{DM_OUT} = 3.3\text{ V to } 0.3\text{ V}$ $V_{EN} = 0\text{ V}$	-250	--	250	nA
$I_{DP_IN_OFF}, I_{DM_IN_OFF}$	Off-Leakage Current	$V_{IN} = 3.6\text{ V}$ $V_{DP_IN} = V_{DM_IN} = 3.3\text{ V to } 0.3\text{ V}$ $V_{EN} = V_{IN}$	-250	--	250	nA

Electrical Characteristics - Dynamic Performance

$V_{DD} = 5.0\text{ V}$, $T_A = 25\text{ °C}$ (unless specified otherwise)

Symbol	Parameter	Condition/Note	Min.	Typ.	Max.	Unit
T_{ON}	Turn On Time	V_{DP_OUT} or $V_{DM_OUT} = 1.5\text{ V}$ $R_L = 300\ \Omega$ $C_L = 35\text{ pF}$	--'	20	100	μs
T_{OFF}	Turn Off Time	V_{DP_OUT} or $V_{DM_OUT} = 1.5\text{ V}$ $R_L = 300\ \Omega$ $C_L = 35\text{ pF}$	--'	1	5	μs
T_{PLH}, T_{PHL}	DP_OUT/DM_OUT Switch Propagation Delay	$R_L = R_S = 50\ \Omega$	--	60	--	ps



Electrical Characteristics - Dynamic Performance

$V_{DD} = 5.0\text{ V}$, $T_A = 25\text{ }^\circ\text{C}$ (unless specified otherwise)

Symbol	Parameter	Condition/Note	Min.	Typ.	Max.	Unit
T_{SKEW}	Output Skew	Skew between DP_IN and DM_IN when connected to DP_OUT and DM_OUT $R_L = R_S = 50\ \Omega$	--	40	--	ps
C_{OFF}	DP_OUT/DM_OUT Off-Capacitance	$f = 1\text{ MHz}$	--'	2.0	--	pF
C_{ON}	DP_IN/DM_IN On-Capacitance	$f = 240\text{ MHz}$	--'	4.0	5.5	pF
BW	-3dB Bandwidth	$R_L = R_S = 50\ \Omega$	--	1000	--	MHz
V_{ISO}	Off-Isolation	$V_{DP_OUT}, V_{DP_IN} = 0\text{ dBm}$ $R_L = R_S = 50\ \Omega$ $f = 250\text{ MHz}$	--	-20	--	dB
V_{CT}	Crosstalk	$V_{DP_OUT}, V_{DP_IN} = 0\text{ dBm}$ $R_L = R_S = 50\ \Omega$ $f = 250\text{ MHz}$	--	-25	--	dB



Parameter Measurement Information

Test Circuit

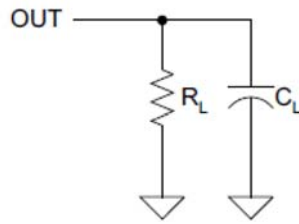

Voltage Waveform

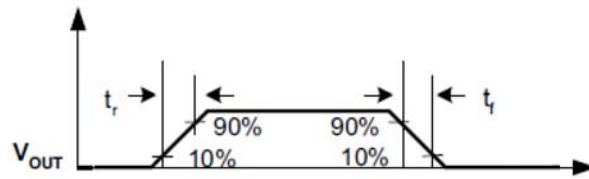

Voltage Waveforms

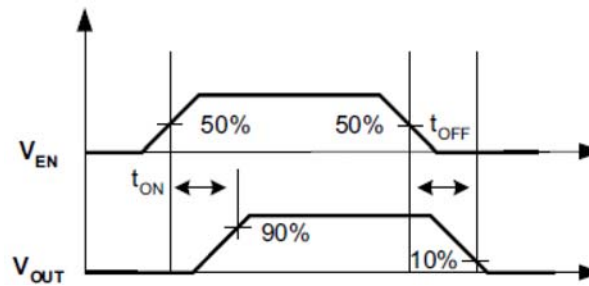

Response Time to Short-Circuit Waveforms

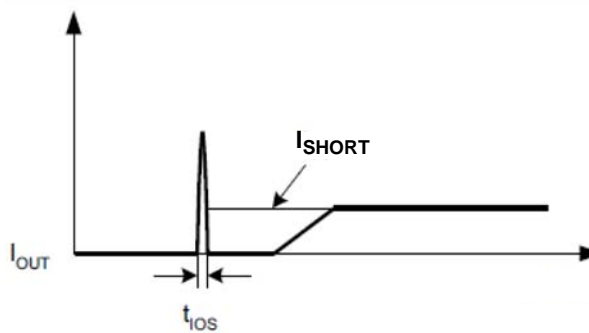



DCP BC1.2 Operation

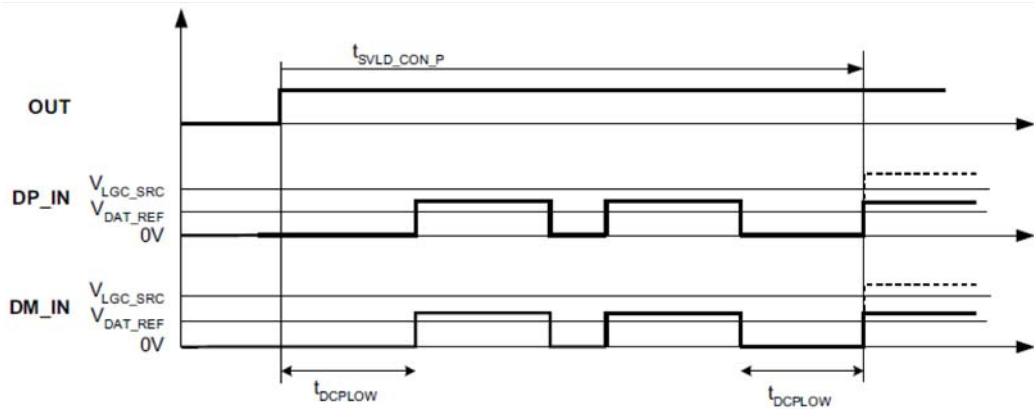

VOU Discharge During CTL Lines Change

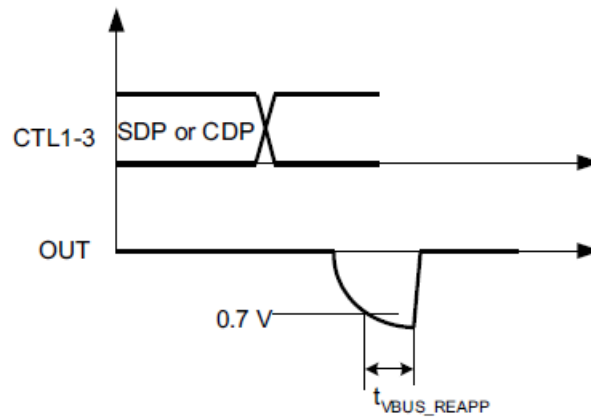



Overview

The following overview references various industry standards. It is always recommended to consult the most up-to-date standard to ensure the most recent and accurate information. Rechargeable portable equipment requires an external power source to charge its batteries. USB ports are a convenient location for charging because of an available 5 V power source. Universally accepted standards are required to make sure host and client-side devices operate together in a system to ensure power management requirements are met. Traditionally, USB host ports following the USB 2.0 specification must provide at least 500 mA to downstream client-side devices. Because multiple USB devices can be attached to a single USB port through a bus-powered hub, it is the responsibility of the client-side device to negotiate its power allotment from the host to ensure the total current draw does not exceed 500 mA. In general, each USB device is granted 100 mA and may request more current in 100 mA unit steps up to 500 mA. The host may grant or deny based on the available current.

Additionally, the success of USB has made the mini-USB connector a popular choice for wall adapter cables. This allows a portable device to charge from both a wall adapter and USB port with only one connector. One common difficulty has resulted from this. As USB charging has gained popularity, the 500 mA minimum defined by USB 2.0 has become insufficient for many handset and personal media players which need a higher charging rate. On the other hand, wall adapters can provide much more current than 500 mA. Several new standards have been introduced defining protocol handshaking methods that allow host and client devices to acknowledge and draw additional current beyond the 500 mA minimum defined by USB 2.0 while still using a single micro-USB input connector.

The SLG55544 supports three of the most common protocols:

- USB 2.0 Battery Charging Specification BC1.2
- Chinese Telecommunications Industry Standard YD/T 1591-2009
- Divider Mode

All three methods have similarities and differences, but the biggest commonality is that all three define three types of charging ports that provide charging current to client-side devices. These charging ports are defined as:

- Standard Downstream Port (SDP)
- Charging Downstream Port (CDP)
- Dedicated Charging Port (DCP)

BC1.2 defines a Charging Port as a downstream facing USB port that provides power for charging portable equipment. The table below shows the differences between these ports according to BC1.2 (draft).

Operating Modes

Port Type	Supports USB 2.0 Communication	Maximum Allowable Current Draw By Portable Equipment (A)
SDP (USB 2.0)	Yes	0.5
SDP (USB 3.0)	Yes	0.9
CDP	Yes	1.5
DCP	No	1.5

BC1.2 (draft) defines the protocol necessary to allow portable equipment to determine what type of port it is connected to so that it can allot its maximum allowable current draw. The hand-shaking process has two steps. During step one, the primary detection, the portable equipment outputs a nominal 0.6-V output on its D+ line and reads the voltage input on its D- line. The portable device concludes it is connected to an SDP if the voltage is less than the nominal data detect voltage of 0.3 V. The portable device concludes that it is connected to a Charging Port if the D- voltage is greater than the nominal data detect voltage of 0.3 V and less than 0.8 V. The second step, the secondary detection, is necessary for portable equipment to determine between a CDP and a DCP. The portable device outputs a nominal 0.6 V output on its D- line and reads the voltage input on its D+ line. The portable device concludes it is connected to a CDP if the data line being read remains less than the nominal data detect voltage of 0.3 V. The portable device concludes it is connected to a DCP if the data line being read is greater than the nominal data detect voltage of 0.3V and less than 0.8 V.



Standard Downstream Port (SDP)

An SDP is a traditional USB port that follows USB 2.0/3.0 and supplies a maximum of 500 mA per port for USB 2.0 and 900 mA per port for USB 3.0. USB 2.0 communications is supported, and the host controller must be active to allow charging.

Charging Downstream Port (CDP)

A CDP is a USB port that follows USB 2.0/3.0 BC1.2 (draft) and supplies a minimum of 1.5 A per port. It provides power and meets USB 2.0/3.0 requirements for device enumeration. USB 2.0/3.0 communications is supported, and the host controller must be active to allow charging. What separates a CDP from an SDP is the host-charge handshaking logic that identifies this port as a CDP. A CDP is identifiable by a compliant BC1.2 (draft) client device and allows for additional current draw by the client device.

The CDP hand-shaking process is two steps. During step one the portable equipment outputs a nominal 0.6 V output on its D+ line and reads the voltage input on its D- line. The portable device concludes it is connected to an SDP if the voltage is less than the nominal data detect voltage of 0.3 V. The portable device concludes that it is connected to a Charging Port if the D- voltage is greater than the nominal data detect voltage of 0.3V and less than 0.8 V.

The second step is necessary for portable equipment to determine between a CDP and a DCP. The portable device outputs a nominal 0.6 V output on its D- line and reads the voltage input on its D+ line. The portable device concludes it is connected to a CDP if the data line being read remains less than the nominal data detect voltage of 0.3 V. The portable device concludes it is connected to a DCP if the data line being read is greater than the nominal data detect voltage of 0.3V and less than 0.8 V.

Dedicated Charging Port (DCP)

A DCP is a special type of wall-adaptor used in charging applications that uses a micro-B connector to connect to portable devices. A DCP only provides power and does not support data connection to an upstream port. As shown in following sections, a DCP is identified by the electrical characteristics of its data lines. The SLG55544 emulates DCP in two charging states, namely DCP Forced and DCP Auto. In DCP Forced state the device will support one of the following two DCP charging schemes: Divider1 or Shorted. In DCP Auto state, the SLG55544 charge detection state machine is enabled which will selectively implement charging schemes involved with the Shorted, Divider1, Divider2, and 1.2 V modes.

Shorted DCP mode complies with BC1.2 and Chinese Telecommunications Industry Standard YD/T 1591-2009,

Divider and 1.2V modes are used to charge devices that do not comply with BC1.2 DCP standard.

High-Bandwidth Data Line Switch

The SLG55544 passes the D+ and D- data lines through the device to enable monitoring and handshaking while supporting charging operation. A wide bandwidth signal switch is used, allowing data to pass through the device without corrupting signal integrity. The data line switches are turned on in any of CDP or SDP operating modes. The EN input also needs to be at logic High for the data line switches to be enabled.

Note:

1. While in CDP mode, the data switches are ON even while CDP handshaking is occurring.
2. The data line switches are OFF if EN is low, or if in DCP mode (BC1.2 (draft), Divider mode or Auto-detect). They are not automatically turned off if the power switch (IN to OUT) is doing current limiting. With SLG55544, the data line switches are also off when in "000" mode.
3. The data switches are for USB 2.0 differential pair only. In the case of a USB 3.0 host, the super speed differential pairs must be routed directly to the USB connector without passing through the SLG55544.



Logic Control Modes

The SLG55544 supports the listed standards above for the SDP, CDP and DCP modes using the CTL1, CTL2, and CTL3 logic I/O control pins, although their truth tables are different as shown below. The different CTLx settings correspond to the different types of charge modes. Also, using the Auto-Detect Mode, the Divider Mode or BC1.2 (draft) / YD/T 1591-2009 can be automatically selected without external user interaction

Note:

With the SLG55544, if the “000” mode is selected, the power switch will be turned off and an output discharge resistor will be connected, while the data line switches will be turned off.

SLG55544 Control Truth Table

CTL1	CTL2	CTL3	ILIM_SEL	MODE	Current Limit Settings	Note
0	0	0	0	Discharge	N/A	Output held LOW
0	0	0	1	Discharge	N/A	Output held LOW
0	0	1	0	DCP Auto	ILIM_H	Data Lines Disconnected
0	0	1	1	DCP Auto	ILIM_H	Data Lines Disconnected
0	1	0	0	SDP1	ILIM_L	Data Lines Connected
0	1	0	1	SDP1	ILIM_H	Data Lines Connected
0	1	1	0	DCP Auto	ILIM_H	Data Lines Disconnected
0	1	1	1	DCP Auto	ILIM_H	Data Lines Disconnected
1	0	0	0	DCP Shorted	ILIM_L	Device forced to stay in DCP BC 1.2 charging mode
1	0	0	1	DCP Shorted	ILIM_H	Device forced to stay in DCP BC 1.2 charging mode
1	0	1	0	DCP / Divider1	ILIM_L	Device forced to stay in DCP Divider1 charging mode
1	0	1	1	DCP / Divider1	ILIM_H	Device forced to stay in DCP Divider1 charging mode
1	1	0	0	SDP1	ILIM_L	Data Lines Connected
1	1	0	1	SDP1	ILIM_H	Data Lines Connected
1	1	1	0	SDP2 ¹	ILIM_L	Data Lines Connected
1	1	1	1	CDP ^{1,2}	ILIM_H	Data Lines Connected

Notes:

1. No VOUT discharge when charging between 1111 and 1110.
2. CDP Load present governed by the SMART-CDP function.



Output Discharge

To allow a charging port to renegotiate current with a portable device, SLG55544 uses the VBUS discharge function. It proceeds by turning off the power switch while discharging VOUT, then turning back ON the power switch to reassert the VOUT voltage. This discharge function is automatically applied when a change at the CTLx lines results in any of the following mode transitions.

- Any transition to and from CDP
- Any transition to and from SDP

In addition to this, can be achieved using the mode “000”.

Overcurrent Protection

When an over-current condition is detected, the device maintains a constant output current and reduces the output voltage accordingly. Two possible overload conditions can occur. In the first condition, the output has been shorted before the device is enabled or before VIN has been applied.

The SLG55544 senses the short and immediately switches into a constant-current output. In the second condition, a short or an overload occurs while the device is enabled. At the instant the overload occurs, high currents may flow for nominally one to two microseconds before the current-limit circuit can react. The device operates in constant-current mode after the current-limit circuit has responded. Complete shutdown occurs only if the fault is present long enough to activate thermal limiting. The device will remain off until the junction temperature cools approximately 10°C and will then re-start. The device will continue to cycle on/off until the over-current condition is removed.

FAULT# Response

The FAULT# open-drain output is asserted (active low) during an over-temperature or current limit condition. The output remains asserted until the fault condition is removed. The SLG55544 is designed to eliminate false FAULT# reporting by using an internal deglitch circuit for current limit conditions without the need for external circuitry. This ensures that FAULT# is not accidentally asserted due to normal operation such as starting into a heavy capacitive load. Over-temperature conditions are not deglitched and assert the FAULT# signal immediately.

Undervoltage Lockout (UVLO)

The undervoltage lockout (UVLO) circuit disables the power switch until the input voltage reaches the UVLO turn-on threshold. Built-in hysteresis prevents unwanted oscillations on the output due to input voltage drop from large current surges.

Thermal Sense

The SLG55544 protects itself with two independent thermal sensing circuits that monitor the operating temperature of the power distribution switch and disables operation if the temperature exceeds recommended operating conditions. The device operates in constant-current mode during an over-current condition, which increases the voltage drop across power switch. The power dissipation in the package is proportional to the voltage drop across the power switch, so the junction temperature rises during an over-current condition. The first thermal sensor turns off the power switch when the die temperature exceeds 135°C and the part is in current limit. The second thermal sensor turns off the power switch when the die temperature exceeds 155°C regardless of whether the power switch is in current limit. Hysteresis is built into both thermal sensors, and the switch turns on after the device has cooled by approximately 10°C. The switch continues to cycle off and on until the fault is removed. The open-drain false reporting output FAULT# is asserted (active low) during an over-temperature shutdown condition.



Package Top Marking System Definition

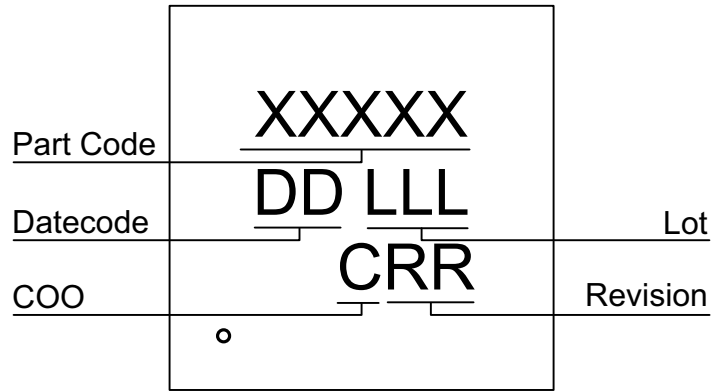

- XXXXX – Part ID Field: identifies the specific device configuration
- DD – Date Code Field: Coded date of manufacture
- LLL – Lot Code: Designates Lot #
- C – Assembly Site/COO: Specifies Assembly Site/Country of Origin
- RR – Revision Code: Device Revision



Package Drawing and Dimensions

16 Lead TQFN Package

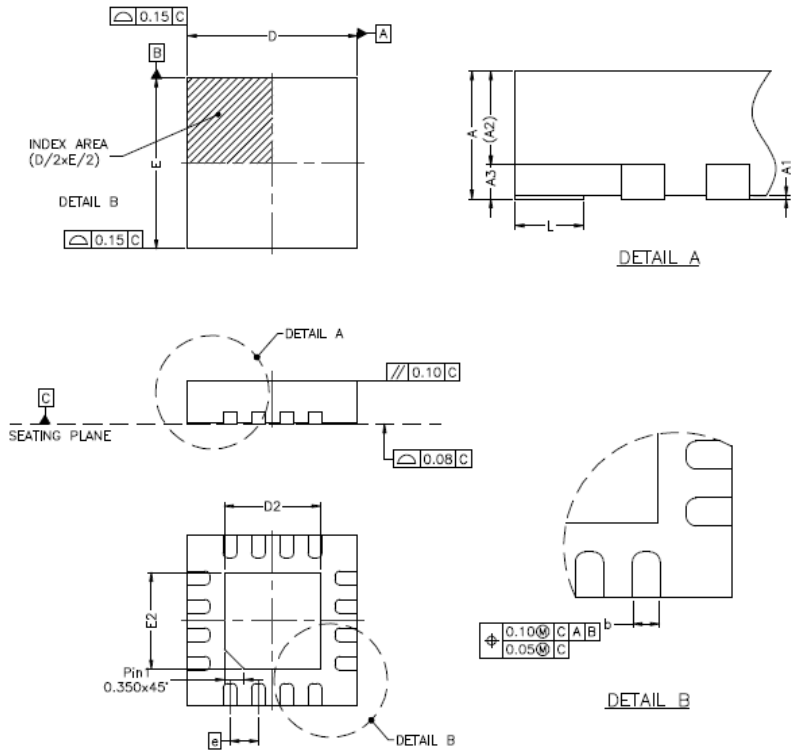

SYMBOL	DIMENSION (MM)			DIMENSION (MIL)		
	MIN.	NOM.	MAX.	MIN.	NOM.	MAX.
A	0.70	0.75	0.80	28	30	31
A1	0.00	0.02	0.05	0	1	2
A2	0	0.55	0.80	0	22	31
A3	-	0.20	-	-	8	-
b	0.18	0.25	0.30	7	10	12
D	2.90	3.00	3.10	114	118	122
D1	-	-	-	-	-	-
D2	1.60	1.70	1.80	63	67	71
E	2.90	3.00	3.10	114	118	122
E1	-	-	-	-	-	-
E2	1.60	1.70	1.80	63	67	71
e	0.50 BSC			20 BSC		
L	0.35	0.40	0.45	14	16	18

NOTE :

1. REFER TO JEDEC STD: MO-220.
2. DIMENSION "b" APPLIES TO METALLIZED TERMINAL AND IS MEASURED BETWEEN 0.15MM AND 0.30MM FROM THE TERMINAL TIP. IF THE TERMINAL HAS OPTIONAL RADIUS ON THE OTHER END OF THE TERMINAL, THE DIMENSION B SHOULD NOT BE MEASURED IN THAT RADIUS AREA.



Tape and Reel Specifications

Package Type	# of Pins	Nominal Package Size [mm]	Tape Width [mm]	Part Pitch [mm]	Leader (min)		Trailer (min)		Reel Diameter [mm]	Max Units	
					Pockets	Length [mm]	Pockets	Length [mm]		per Reel	per Box
16TQFN	16	3 x 3 x 0.75	12	8	42	336	42	336	330	5,000	10,000

Tape and Reel Drawing and Dimensions

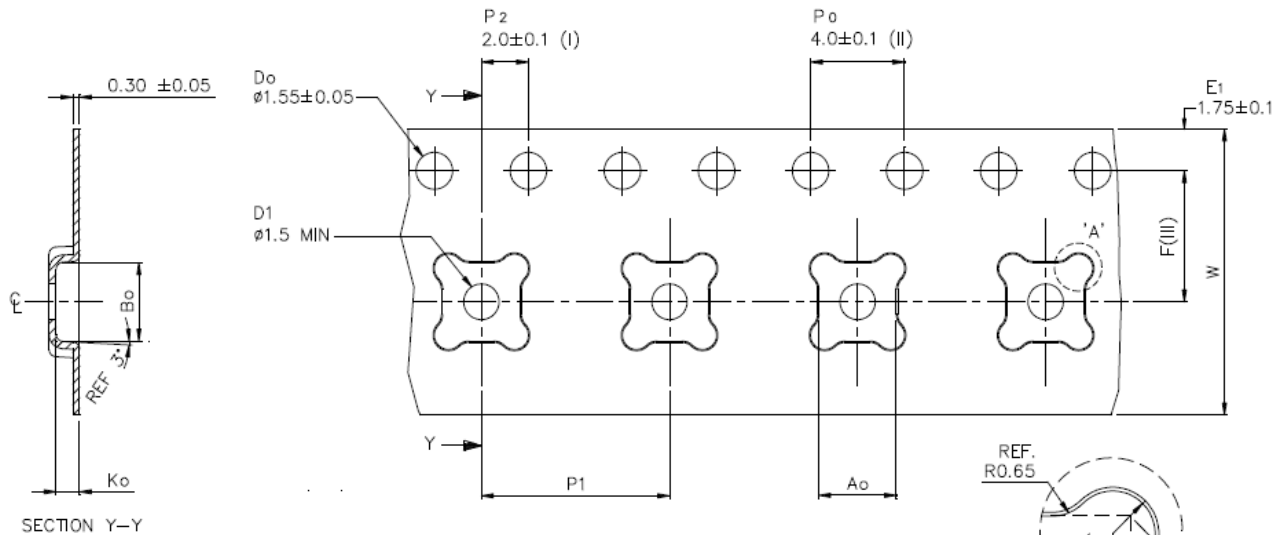

Ao	3.30 + 0.10 / - 0.15
Bo	3.30 + 0.10 / - 0.15
Ko	1.00 + 0.25 / - 0.20
F	5.50 +/- 0.10
P1	8.00 +/- 0.10
W	12.00 +/- 0.30

- (I) Measured from centreline of sprocket hole to centreline of pocket.
- (II) Cumulative tolerance of 10 sprocket holes is ± 0.20 .
- (III) Measured from centreline of sprocket hole to centreline of pocket.
- (IV) Other material available.

ALL DIMENSIONS IN MILLIMETRES UNLESS OTHERWISE STATED.

Recommended Reflow Soldering Profile

Please see IPC/JEDEC J-STD-020: latest revision for reflow profile based on package volume of 6.75 mm³ (nominal). More information can be found at www.jedec.org.



Revision History

Date	Version	Change
2/4/2016	1.03	Fixed typos and formatting
9/8/2015	1.02	Updated Recommended Operating Conditions Added Recommended Reflow Soldering Profile



Silego Website & Support

Silego Technology Website

Silego Technology provides online support via our website at <http://www.silego.com/>. This website is used as a means to make files and information easily available to customers.

For more information regarding Silego Green products, please visit:

GreenPAK

<http://greenpak.silego.com/>

<http://greenpak2.silego.com/>

<http://greenpak3.silego.com/>

GreenFET

<http://greenfet.silego.com/>

<http://greenfet2.silego.com/>

<http://greenfet3.silego.com/>

GreenCLK

<http://greenclk.silego.com/>

<http://greenclk2.silego.com/>

<http://greenclk3.silego.com/>

Products are also available for purchase directly from Silego at the Silego Online Store at <http://store.silego.com/>.

Silego Technical Support

Datasheets and errata, application notes and example designs, user guides, and hardware support documents and the latest software releases are available at the Silego website or can be requested directly at info@silego.com.

For specific GreenPAK design or applications questions and support please send e-mail requests to GreenPAK@silego.com

Users of Silego products can receive assistance through several channels:

Online Live Support

Silego Technology has live video technical assistance and sales support available at <http://www.silego.com/>. Please ask our live web receptionist to schedule a 1 on 1 training session with one of our application engineers.

Contact Your Local Sales Representative

Customers can contact their local sales representative or field application engineer (FAE) for support. Local sales offices are also available to help customers. More information regarding your local representative is available at the Silego website or send a request to info@silego.com

Contact Silego Directly

Silego can be contacted directly via e-mail at info@silego.com or user submission form, located at the following URL:

<http://support.silego.com/>

Other Information

The latest Silego Technology press releases, listing of seminars and events, listings of world wide Silego Technology offices and representatives are all available at <http://www.silego.com/>

THIS PRODUCT HAS BEEN DESIGNED AND QUALIFIED FOR THE CONSUMER MARKET. APPLICATIONS OR USES AS CRITICAL COMPONENTS IN LIFE SUPPORT DEVICES OR SYSTEMS ARE NOT AUTHORIZED. SILEGO TECHNOLOGY DOES NOT ASSUME ANY LIABILITY ARISING OUT OF SUCH APPLICATIONS OR USES OF ITS PRODUCTS. SILEGO TECHNOLOGY RESERVES THE RIGHT TO IMPROVE PRODUCT DESIGN, FUNCTIONS AND RELIABILITY WITHOUT NOTICE.

Компания «Океан Электроники» предлагает заключение долгосрочных отношений при поставках импортных электронных компонентов на взаимовыгодных условиях!

Наши преимущества:

- Поставка оригинальных импортных электронных компонентов напрямую с производств Америки, Европы и Азии, а так же с крупнейших складов мира;
- Широкая линейка поставок активных и пассивных импортных электронных компонентов (более 30 млн. наименований);
- Поставка сложных, дефицитных, либо снятых с производства позиций;
- Оперативные сроки поставки под заказ (от 5 рабочих дней);
- Экспресс доставка в любую точку России;
- Помощь Конструкторского Отдела и консультации квалифицированных инженеров;
- Техническая поддержка проекта, помощь в подборе аналогов, поставка прототипов;
- Поставка электронных компонентов под контролем ВП;
- Система менеджмента качества сертифицирована по Международному стандарту ISO 9001;
- При необходимости вся продукция военного и аэрокосмического назначения проходит испытания и сертификацию в лаборатории (по согласованию с заказчиком);
- Поставка специализированных компонентов военного и аэрокосмического уровня качества (Xilinx, Altera, Analog Devices, Intersil, Interpoint, Microsemi, Actel, Aeroflex, Peregrine, VPT, Syfer, Eurofarad, Texas Instruments, MS Kennedy, Miteq, Cobham, E2V, MA-COM, Hittite, Mini-Circuits, General Dynamics и др.);

Компания «Океан Электроники» является официальным дистрибьютором и эксклюзивным представителем в России одного из крупнейших производителей разъемов военного и аэрокосмического назначения «JONHON», а так же официальным дистрибьютором и эксклюзивным представителем в России производителя высокотехнологичных и надежных решений для передачи СВЧ сигналов «FORSTAR».



JONHON

«JONHON» (основан в 1970 г.)

Разъемы специального, военного и аэрокосмического назначения:

(Применяются в военной, авиационной, аэрокосмической, морской, железнодорожной, горно- и нефтедобывающей отраслях промышленности)

«FORSTAR» (основан в 1998 г.)

ВЧ соединители, коаксиальные кабели, кабельные сборки и микроволновые компоненты:

(Применяются в телекоммуникациях гражданского и специального назначения, в средствах связи, РЛС, а так же военной, авиационной и аэрокосмической отраслях промышленности).



Телефон: 8 (812) 309-75-97 (многоканальный)

Факс: 8 (812) 320-03-32

Электронная почта: ocean@oceanchips.ru

Web: <http://oceanchips.ru/>

Адрес: 198099, г. Санкт-Петербург, ул. Калинина, д. 2, корп. 4, лит. А