

IS61WV20488ALL IS61/64WV20488BLL



2M x 8 HIGH-SPEED CMOS STATIC RAM

AUGUST 2010

FEATURES

- High-speed access times:
8, 10, 20 ns
- High-performance, low-power CMOS process
- Multiple center power and ground pins for greater noise immunity
- Easy memory expansion with \overline{CE} and \overline{OE} options
- \overline{CE} power-down
- Fully static operation: no clock or refresh required
- TTL compatible inputs and outputs
- Single power supply
 - V_{DD} 1.65V to 2.2V (IS61WV20488ALL)
speed = 20ns for V_{cc} = 1.65V to 2.2V
 - V_{DD} 2.4V to 3.6V (IS61/64WV20488BLL)
speed = 10ns for V_{cc} = 2.4V to 3.6V
speed = 8ns for V_{cc} = 3.3V ± 5%
- Packages available:
 - 48-ball miniBGA (9mm x 11mm)
 - 44-pin TSOP (Type II)
- Industrial and Automotive Temperature Support
- Lead-free available

DESCRIPTION

The *ISSI* IS61WV20488ALL/BLL and IS64WV20488BLL are very high-speed, low power, 2M-word by 8-bit CMOS static RAM. The IS61WV20488ALL/BLL and IS64WV20488BLL are fabricated using *ISSI*'s high-performance CMOS technology. This highly reliable process coupled with innovative circuit design techniques, yields higher performance and low power consumption devices.

When \overline{CE} is HIGH (deselected), the device assumes a standby mode at which the power dissipation can be reduced down with CMOS input levels.

The IS61WV20488ALL/BLL and IS64WV20488BLL operate from a single power supply and all inputs are TTL-compatible.

The IS61WV20488ALL/BLL and IS64WV20488BLL are available in 48 ball mini BGA and 44-pin TSOP (Type II) packages.

FUNCTIONAL BLOCK DIAGRAM

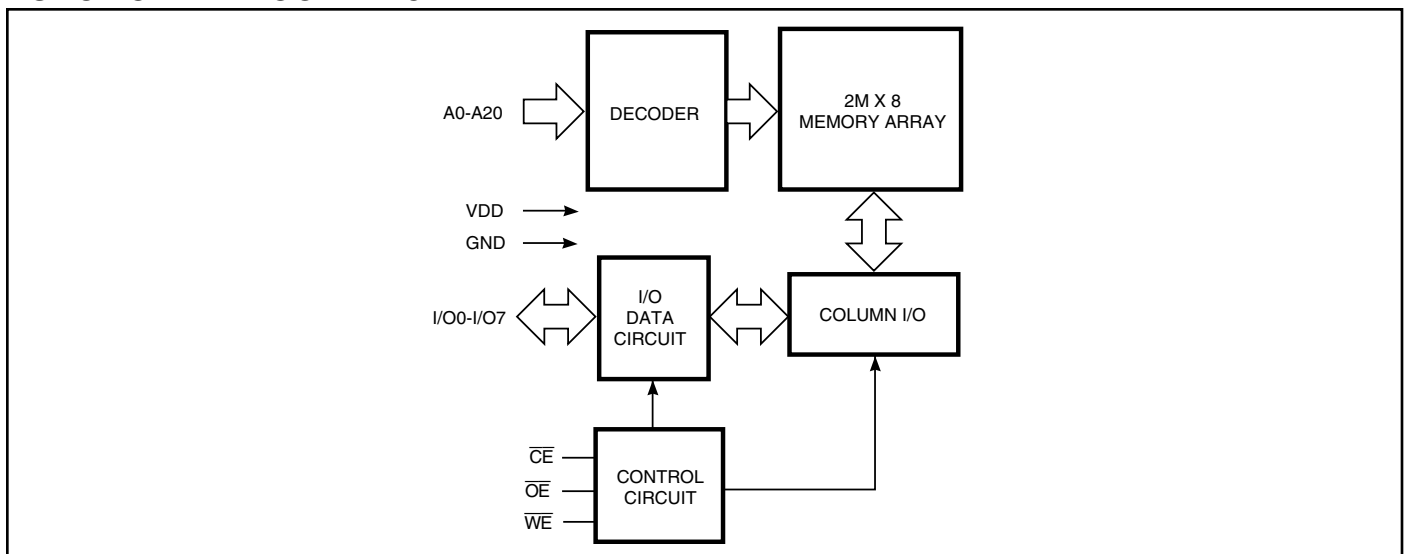

Copyright © 2010 Integrated Silicon Solution, Inc. All rights reserved. ISSI reserves the right to make changes to this specification and its products at any time without notice. ISSI assumes no liability arising out of the application or use of any information, products or services described herein. Customers are advised to obtain the latest version of this device specification before relying on any published information and before placing orders for products.

Integrated Silicon Solution, Inc. does not recommend the use of any of its products in life support applications where the failure or malfunction of the product can reasonably be expected to cause failure of the life support system or to significantly affect its safety or effectiveness. Products are not authorized for use in such applications unless Integrated Silicon Solution, Inc. receives written assurance to its satisfaction, that:

- a.) the risk of injury or damage has been minimized;
- b.) the user assume all such risks; and
- c.) potential liability of Integrated Silicon Solution, Inc is adequately protected under the circumstances

PIN CONFIGURATION

48-pin Mini BGA (M) (9mm x 11mm)

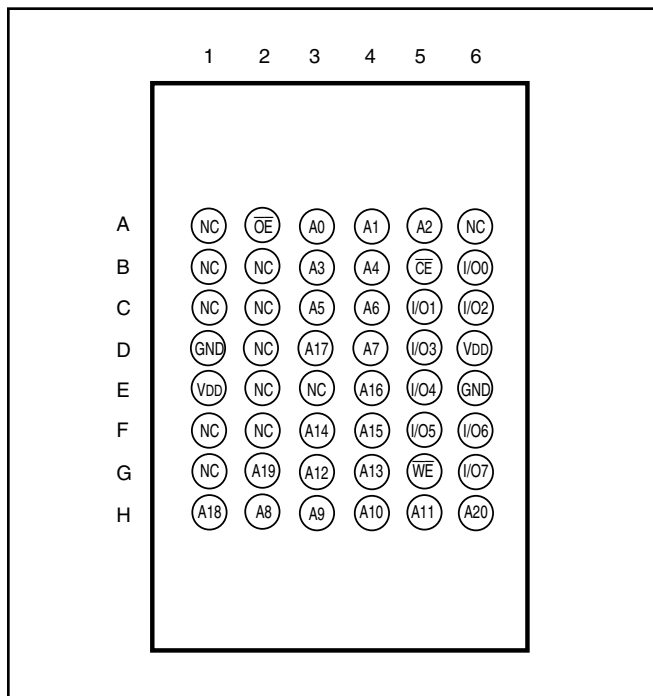

44-pin TSOP (Type II)

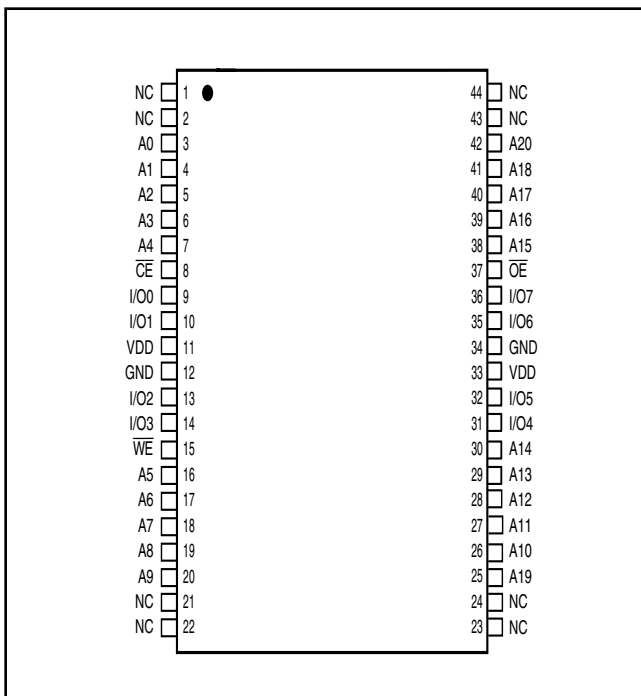

PIN DESCRIPTIONS

A0-A20	Address Inputs
\overline{CE}	Chip Enable Input
\overline{OE}	Output Enable Input
\overline{WE}	Write Enable Input
I/O0-I/O7	Data Input / Output
VDD	Power
GND	Ground
NC	No Connection

TRUTH TABLE

Mode	\overline{WE}	\overline{CE}	\overline{OE}	I/O Operation	V _{DD} Current
Not Selected (Power-down)	X	H	X	High-Z	I _{SB1} , I _{SB2}
Output Disabled	H	L	H	High-Z	I _{CC}
Read	H	L	L	D _{OUT}	I _{CC}
Write	L	L	X	D _{IN}	I _{CC}

ABSOLUTE MAXIMUM RATINGS⁽¹⁾

Symbol	Parameter	Value	Unit
V _{TERM}	Terminal Voltage with Respect to GND	-0.5 to V _{DD} + 0.5	V
V _{DD}	V _{DD} Relates to GND	-0.3 to 4.0	V
T _{STG}	Storage Temperature	-65 to +150	°C
P _T	Power Dissipation	1.0	W

Notes:

1. Stress greater than those listed under ABSOLUTE MAXIMUM RATINGS may cause permanent damage to the device. This is a stress rating only and functional operation of the device at these or any other conditions above those indicated in the operational sections of this specification is not implied. Exposure to absolute maximum rating conditions for extended periods may affect reliability.

CAPACITANCE^(1,2)

Symbol	Parameter	Conditions	Max.	Unit
C _{IN}	Input Capacitance	V _{IN} = 0V	6	pF
C _{I/O}	Input/Output Capacitance	V _{OUT} = 0V	8	pF

Notes:

1. Tested initially and after any design or process changes that may affect these parameters.
2. Test conditions: T_A = 25°C, f = 1 MHz, V_{DD} = 3.3V.

OPERATING RANGE (V_{DD}) (IS61WV20488ALL)

Range	Ambient Temperature	V _{DD} (20 ns)
Commercial	0°C to +70°C	1.65V-2.2V
Industrial	-40°C to +85°C	1.65V-2.2V
Automotive	-40°C to +125°C	1.65V-2.2V

OPERATING RANGE (V_{DD}) (IS61WV20488BLL)⁽¹⁾

Range	Ambient Temperature	V _{DD} (8 ns)	V _{DD} (10 ns)
Commercial	0°C to +70°C	3.3V ± 5%	2.4V-3.6V
Industrial	-40°C to +85°C	3.3V ± 5%	2.4V-3.6V

Note:

1. When operated in the range of 2.4V-3.6V, the device meets 10ns. When operated in the range of 3.3V ± 5%, the device meets 8ns.

OPERATING RANGE (V_{DD}) (IS64WV20488BLL)

Range	Ambient Temperature	V _{DD} (10 ns)
Automotive	-40°C to +125°C	2.4V-3.6V

DC ELECTRICAL CHARACTERISTICS (Over Operating Range)

 $V_{DD} = 3.3V \pm 5\%$

Symbol	Parameter	Test Conditions	Min.	Max.	Unit
V_{OH}	Output HIGH Voltage	$V_{DD} = \text{Min.}, I_{OH} = -4.0 \text{ mA}$	2.4	—	V
V_{OL}	Output LOW Voltage	$V_{DD} = \text{Min.}, I_{OL} = 8.0 \text{ mA}$	—	0.4	V
V_{IH}	Input HIGH Voltage		2	$V_{DD} + 0.3$	V
V_{IL}	Input LOW Voltage ⁽¹⁾		-0.3	0.8	V
I_{LI}	Input Leakage	$GND \leq V_{IN} \leq V_{DD}$	-1	1	μA
I_{LO}	Output Leakage	$GND \leq V_{OUT} \leq V_{DD}$, Outputs Disabled	-1	1	μA

Note:

- $V_{IL} (\text{min.}) = -0.3V \text{ DC}; V_{IL} (\text{min.}) = -2.0V \text{ AC}$ (pulse width 2.0 ns). Not 100% tested.
 $V_{IH} (\text{max.}) = V_{DD} + 0.3V \text{ DC}; V_{IH} (\text{max.}) = V_{DD} + 2.0V \text{ AC}$ (pulse width 2.0 ns). Not 100% tested.

DC ELECTRICAL CHARACTERISTICS (Over Operating Range)

 $V_{DD} = 2.4V-3.6V$

Symbol	Parameter	Test Conditions	Min.	Max.	Unit
V_{OH}	Output HIGH Voltage	$V_{DD} = \text{Min.}, I_{OH} = -1.0 \text{ mA}$	1.8	—	V
V_{OL}	Output LOW Voltage	$V_{DD} = \text{Min.}, I_{OL} = 1.0 \text{ mA}$	—	0.4	V
V_{IH}	Input HIGH Voltage		2.0	$V_{DD} + 0.3$	V
V_{IL}	Input LOW Voltage ⁽¹⁾		-0.3	0.8	V
I_{LI}	Input Leakage	$GND \leq V_{IN} \leq V_{DD}$	-1	1	μA
I_{LO}	Output Leakage	$GND \leq V_{OUT} \leq V_{DD}$, Outputs Disabled	-1	1	μA

Note:

- $V_{IL} (\text{min.}) = -0.3V \text{ DC}; V_{IL} (\text{min.}) = -2.0V \text{ AC}$ (pulse width 2.0 ns). Not 100% tested.
 $V_{IH} (\text{max.}) = V_{DD} + 0.3V \text{ DC}; V_{IH} (\text{max.}) = V_{DD} + 2.0V \text{ AC}$ (pulse width 2.0 ns). Not 100% tested.

DC ELECTRICAL CHARACTERISTICS (Over Operating Range)

 $V_{DD} = 1.65V-2.2V$

Symbol	Parameter	Test Conditions	V_{DD}	Min.	Max.	Unit
V_{OH}	Output HIGH Voltage	$I_{OH} = -0.1 \text{ mA}$	1.65-2.2V	1.4	—	V
V_{OL}	Output LOW Voltage	$I_{OL} = 0.1 \text{ mA}$	1.65-2.2V	—	0.2	V
V_{IH}	Input HIGH Voltage		1.65-2.2V	1.4	$V_{DD} + 0.2$	V
$V_{IL}^{(1)}$	Input LOW Voltage		1.65-2.2V	-0.2	0.4	V
I_{LI}	Input Leakage	$GND \leq V_{IN} \leq V_{DD}$		-1	1	μA
I_{LO}	Output Leakage	$GND \leq V_{OUT} \leq V_{DD}$, Outputs Disabled		-1	1	μA

Note:

- $V_{IL} (\text{min.}) = -0.3V \text{ DC}; V_{IL} (\text{min.}) = -2.0V \text{ AC}$ (pulse width 2.0 ns). Not 100% tested.
 $V_{IH} (\text{max.}) = V_{DD} + 0.3V \text{ DC}; V_{IH} (\text{max.}) = V_{DD} + 2.0V \text{ AC}$ (pulse width 2.0 ns). Not 100% tested.

AC TEST CONDITIONS (HIGH SPEED)

Parameter	Unit (2.4V-3.6V)	Unit (3.3V ± 5%)	Unit (1.65V-2.2V)
Input Pulse Level	0.4V to $V_{DD}-0.3V$	0.4V to $V_{DD}-0.3V$	0.4V to $V_{DD}-0.2V$
Input Rise and Fall Times	1.5ns	1.5ns	1.5ns
Input and Output Timing and Reference Level (V_{Ref})	$V_{DD}/2$	$V_{DD}/2 + 0.05$	$V_{DD}/2$
Output Load	See Figures 1 and 2	See Figures 1 and 2	See Figures 1 and 2

AC TEST LOADS

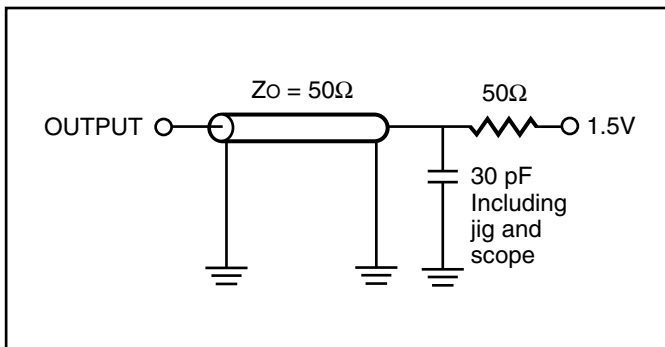

Figure 1.

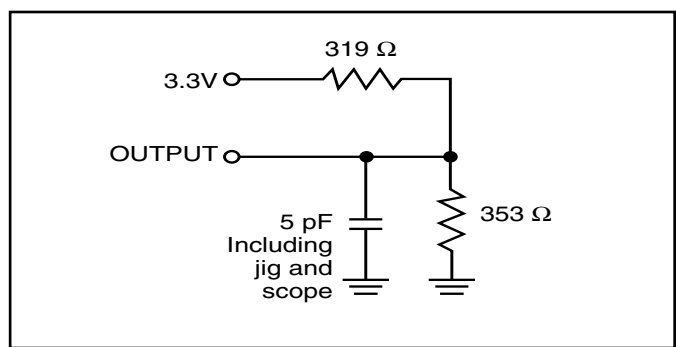

Figure 2.

POWER SUPPLY CHARACTERISTICS⁽¹⁾ (Over Operating Range)

Symbol	Parameter	Test Conditions		-8		-10		-20		Unit
				Min.	Max.	Min.	Max.	Min.	Max.	
I _{CC}	V _{DD} Dynamic Operating Supply Current	V _{DD} = Max., I _{OUT} = 0 mA, f = f _{MAX}	Com.	—	120	—	95	—	90	mA
			Ind.	—	125	—	100	—	100	
			Auto.	—	—	—	140	—	140	
			typ. ⁽²⁾			60				
I _{CC1}	Operating Supply Current	V _{DD} = Max., I _{OUT} = 0 mA, f = 0	Com.	—	35	—	30	—	30	mA
			Ind.	—	35	—	40	—	40	
			Auto.	—	—	—	60	—	70	
I _{SB1}	TTL Standby Current (TTL Inputs)	V _{DD} = Max., V _{IN} = V _{IH} or V _{IL} CE ≥ V _{IH} , f = 0	Com.	—	30	—	30	—	30	mA
			Ind.	—	35	—	35	—	35	
			Auto.	—	—	—	70	—	70	
I _{SB2}	CMOS Standby Current (CMOS Inputs)	V _{DD} = Max., CE ≥ V _{DD} - 0.2V, V _{IN} ≥ V _{DD} - 0.2V, or V _{IN} ≤ 0.2V, f = 0	Com.	—	20	—	20	—	15	mA
			Ind.	—	25	—	25	—	20	
			Auto.	—	—	—	70	—	70	
			typ. ⁽²⁾			4				

Note:

- At f = f_{MAX}, address and data inputs are cycling at the maximum frequency, f = 0 means no input lines change.
- Typical values are measured at V_{DD} = 3.0V, T_A = 25°C and not 100% tested.

READ CYCLE SWITCHING CHARACTERISTICS⁽¹⁾ (Over Operating Range)

Symbol	Parameter	-8		-10		Unit
		Min.	Max.	Min.	Max.	
t _{RC}	Read Cycle Time	8	—	10	—	ns
t _{AA}	Address Access Time	—	8	—	10	ns
t _{OHA}	Output Hold Time	2	—	2	—	ns
t _{ACE}	$\overline{\text{CE}}$ Access Time	—	8	—	10	ns
t _{DOE}	$\overline{\text{OE}}$ Access Time	—	5.5	—	6.5	ns
t _{HZOE⁽²⁾}	$\overline{\text{OE}}$ to High-Z Output	—	3	—	4	ns
t _{LZOE⁽²⁾}	$\overline{\text{OE}}$ to Low-Z Output	0	—	0	—	ns
t _{HZCE⁽²⁾}	$\overline{\text{CE}}$ to High-Z Output	0	3	0	4	ns
t _{LZCE⁽²⁾}	$\overline{\text{CE}}$ to Low-Z Output	3	—	3	—	ns
t _{PU}	Power Up Time	0	—	0	—	ns
t _{PD}	Power Down Time	—	8	—	10	ns

Notes:

1. Test conditions assume signal transition times of 3 ns or less, timing reference levels of 1.5V, input pulse levels of 0V to 3.0V and output loading specified in Figure 1.
2. Tested with the load in Figure 2. Transition is measured ± 500 mV from steady-state voltage.

READ CYCLE SWITCHING CHARACTERISTICS⁽¹⁾ (Over Operating Range)

Symbol	Parameter	-20 ns		Unit
		Min.	Max.	
t _{RC}	Read Cycle Time	20	—	ns
t _{AA}	Address Access Time	—	20	ns
t _{OHA}	Output Hold Time	2.5	—	ns
t _{ACE}	\overline{CE} Access Time	—	20	ns
t _{DOE}	\overline{OE} Access Time	—	8	ns
t _{HZOE⁽²⁾}	\overline{OE} to High-Z Output	0	8	ns
t _{LZOE⁽²⁾}	\overline{OE} to Low-Z Output	0	—	ns
t _{HZCE⁽²⁾}	\overline{CE} to High-Z Output	0	8	ns
t _{LZCE⁽²⁾}	\overline{CE} to Low-Z Output	3	—	ns
t _{PU}	Power Up Time	0	—	ns
t _{PD}	Power Down Time	—	20	ns

Notes:

1. Test conditions assume signal transition times of 1.5 ns or less, timing reference levels of 1.25V, input pulse levels of 0.4V to V_{DD}-0.3V and output loading specified in Figure 1.
2. Tested with the load in Figure 2. Transition is measured ±500 mV from steady-state voltage. Not 100% tested.
3. Not 100% tested.

AC WAVEFORMS

READ CYCLE NO. 1^(1,2) (Address Controlled) ($\overline{CE} = \overline{OE} = V_{IL}$)

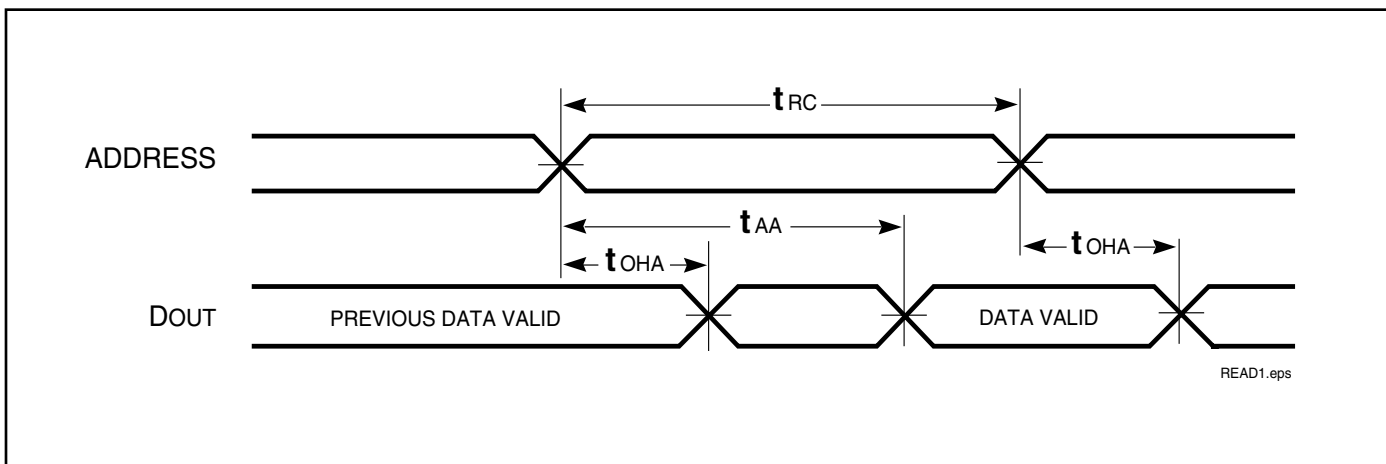

READ CYCLE NO. 2^(1,3) (\overline{CE} and \overline{OE} Controlled)

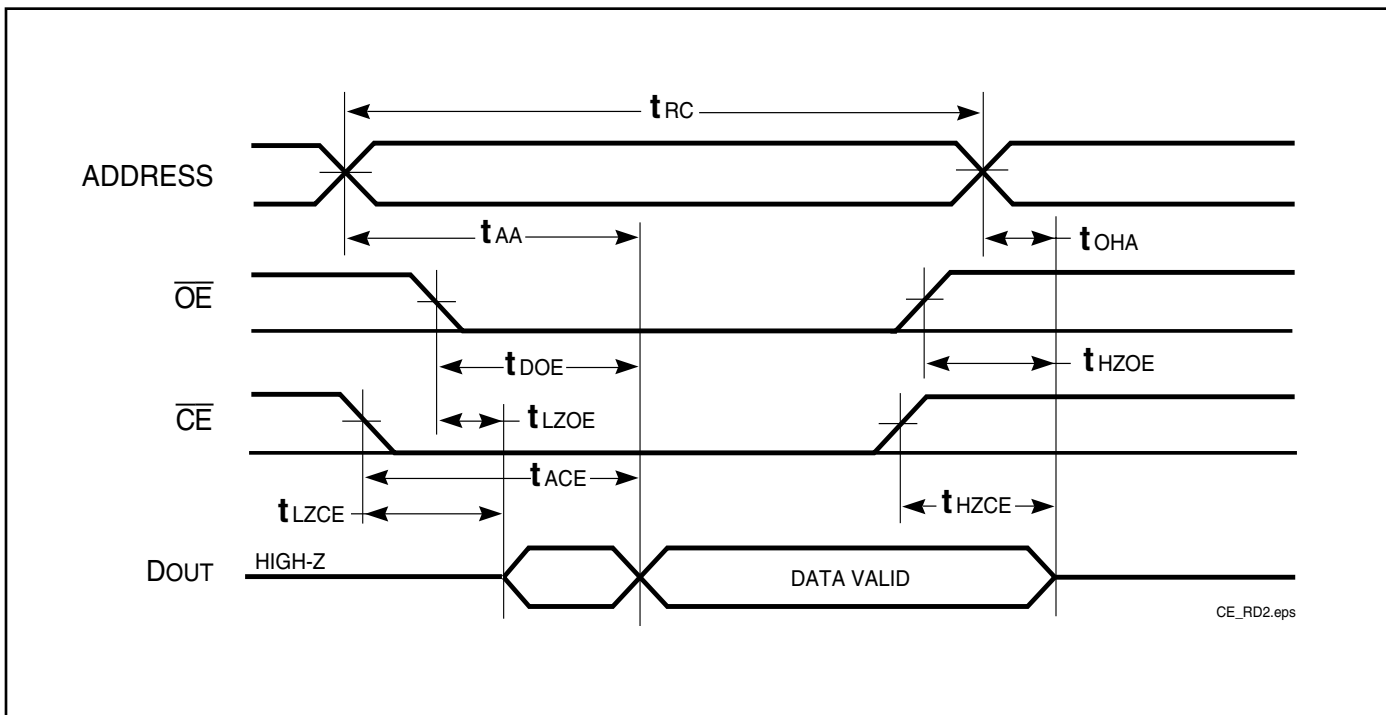

Notes:

1. \overline{WE} is HIGH for a Read Cycle.
2. The device is continuously selected. \overline{OE} , $\overline{CE} = V_{IL}$.
3. Address is valid prior to or coincident with \overline{CE} LOW transitions.

WRITE CYCLE SWITCHING CHARACTERISTICS^(1,3) (Over Operating Range)

Symbol	Parameter	-8		-10		Unit
		Min.	Max.	Min.	Max.	
t _{WC}	Write Cycle Time	8	—	10	—	ns
t _{SCE}	\overline{CE} to Write End	6.5	—	8	—	ns
t _{AW}	Address Setup Time to Write End	6.5	—	8	—	ns
t _{HA}	Address Hold from Write End	0	—	0	—	ns
t _{SA}	Address Setup Time	0	—	0	—	ns
t _{PWE1}	\overline{WE} Pulse Width (\overline{OE} = HIGH)	6.5	—	8	—	ns
t _{PWE2}	\overline{WE} Pulse Width (\overline{OE} = LOW)	8.0	—	10	—	ns
t _{SD}	Data Setup to Write End	5	—	6	—	ns
t _{HD}	Data Hold from Write End	0	—	0	—	ns
t _{HZWE⁽²⁾}	\overline{WE} LOW to High-Z Output	—	3.5	—	5	ns
t _{LZWE⁽²⁾}	\overline{WE} HIGH to Low-Z Output	2	—	2	—	ns

Notes:

1. Test conditions assume signal transition times of 3 ns or less, timing reference levels of 1.5V, input pulse levels of 0V to 3.0V and output loading specified in Figure 1.
2. Tested with the load in Figure 2. Transition is measured ± 500 mV from steady-state voltage. Not 100% tested.
3. The internal write time is defined by the overlap of \overline{CE} LOW and \overline{WE} LOW. All signals must be in valid states to initiate a Write, but any one can go inactive to terminate the Write. The Data Input Setup and Hold timing are referenced to the rising or falling edge of the signal that terminates the write. Shaded area product in development

WRITE CYCLE SWITCHING CHARACTERISTICS^(1,2) (Over Operating Range)

Symbol	Parameter	-20 ns		Unit
		Min.	Max.	
t _{WC}	Write Cycle Time	20	—	ns
t _{SCE}	\overline{CE} to Write End	12	—	ns
t _{AW}	Address Setup Time to Write End	12	—	ns
t _{HA}	Address Hold from Write End	0	—	ns
t _{SA}	Address Setup Time	0	—	ns
t _{PWE1}	\overline{WE} Pulse Width (\overline{OE} = HIGH)	12	—	ns
t _{PWE2}	\overline{WE} Pulse Width (\overline{OE} = LOW)	17	—	ns
t _{SD}	Data Setup to Write End	9	—	ns
t _{HD}	Data Hold from Write End	0	—	ns
t _{HZWE} ⁽³⁾	\overline{WE} LOW to High-Z Output	—	9	ns
t _{LZWE} ⁽³⁾	\overline{WE} HIGH to Low-Z Output	3	—	ns

Notes:

1. Test conditions assume signal transition times of 1.5ns or less, timing reference levels of 1.25V, input pulse levels of 0.4V to V_{DD}-0.3V and output loading specified in Figure 1.
2. Tested with the load in Figure 2. Transition is measured ±500 mV from steady-state voltage. Not 100% tested.
3. The internal write time is defined by the overlap of \overline{CE} LOW and \overline{WE} LOW. All signals must be in valid states to initiate a Write, but any one can go inactive to terminate the Write. The Data Input Setup and Hold timing are referenced to the rising or falling edge of the signal that terminates the write.

AC WAVEFORMS

WRITE CYCLE NO. 1^(1,2) (\overline{CE} Controlled, \overline{OE} = HIGH or LOW)

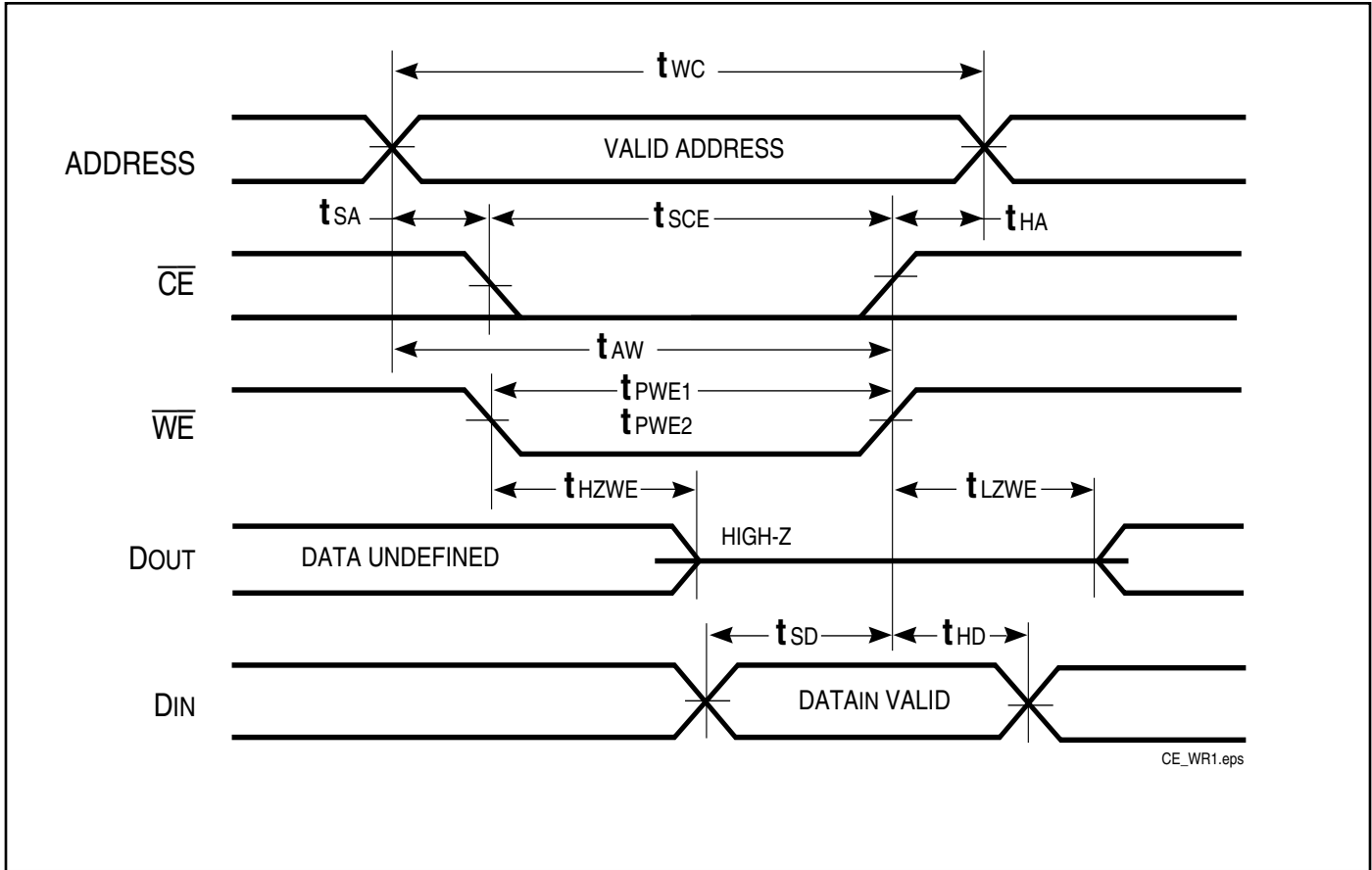

AC WAVEFORMS

WRITE CYCLE NO. 2^(1,2) (\overline{WE} Controlled: \overline{OE} is HIGH During Write Cycle)

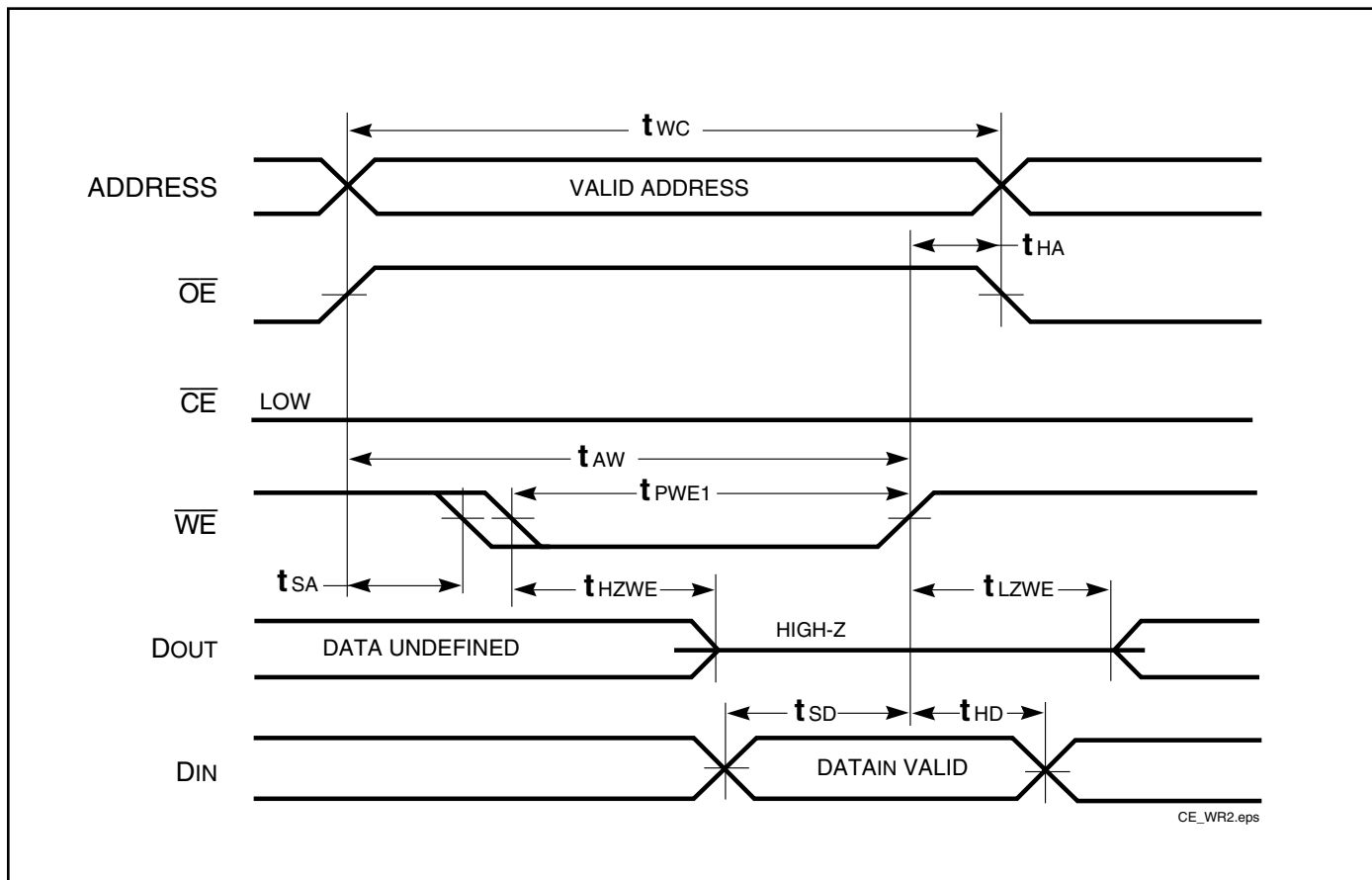

Notes:

1. The internal write time is defined by the overlap of \overline{CE} LOW and \overline{WE} LOW. All signals must be in valid states to initiate a Write, but any one can go inactive to terminate the Write. The Data Input Setup and Hold timing are referenced to the rising or falling edge of the signal that terminates the Write.
2. I/O will assume the High-Z state if $\overline{OE} > V_{IH}$.

AC WAVEFORMS

WRITE CYCLE NO. 3 (\overline{WE} Controlled: \overline{OE} is LOW During Write Cycle)

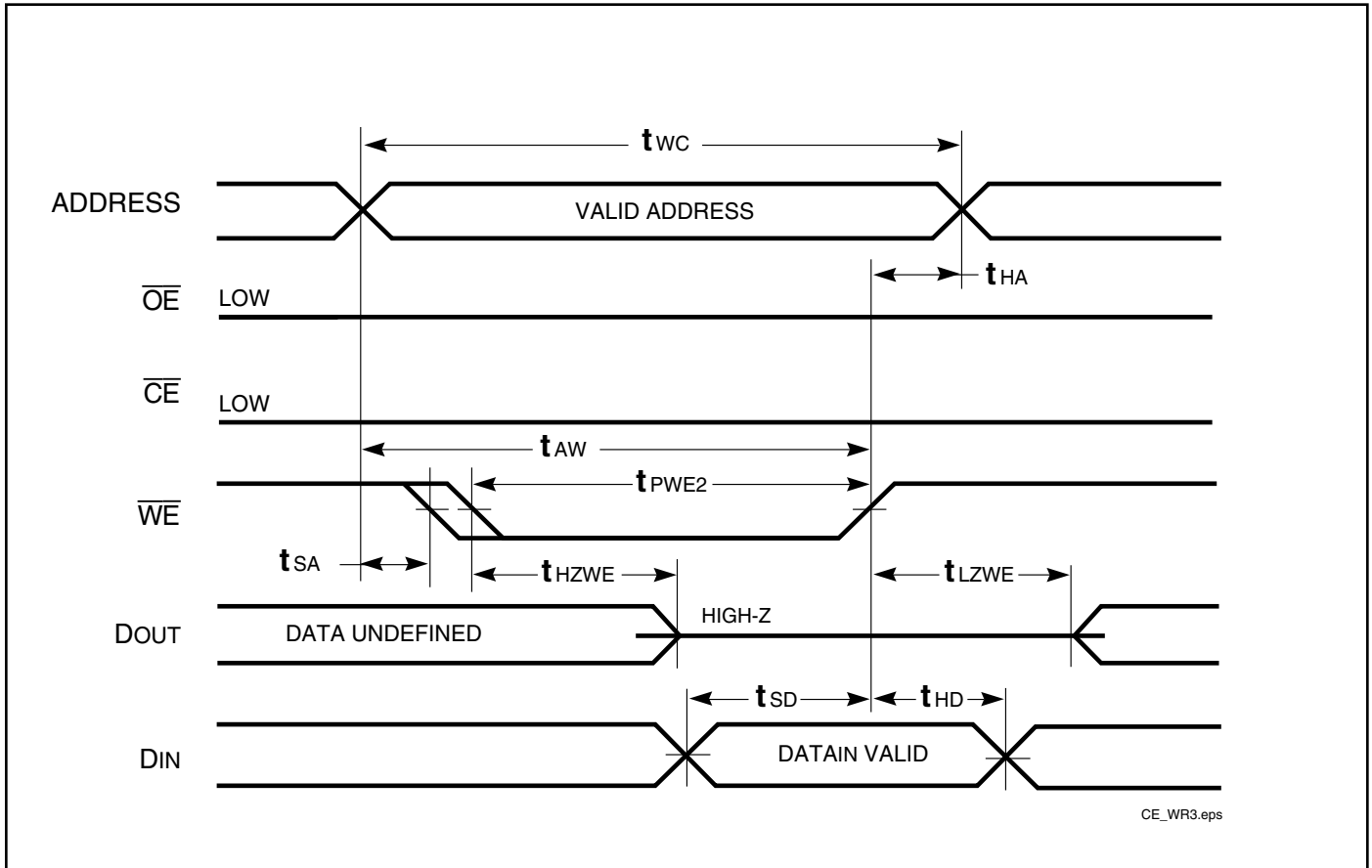

DATA RETENTION SWITCHING CHARACTERISTICS

Symbol	Parameter	Test Condition	Min.	Max.	Unit
V _{DR}	V _{DD} for Data Retention	See Data Retention Waveform	1.2	3.6	V
I _{DR}	Data Retention Current	V _{DD} = 1.2V, $\overline{CE} \geq V_{DD} - 0.2V$	Ind. Auto. typ. ⁽¹⁾	25 60 3	mA
t _{SDR}	Data Retention Setup Time	See Data Retention Waveform	0	—	ns
t _{RDR}	Recovery Time	See Data Retention Waveform	t _{RC}	—	ns

Note:

1. Typical values are measured at V_{DD} = 3.0V, T_A = 25°C and not 100% tested.

DATA RETENTION WAVEFORM (\overline{CE} Controlled)

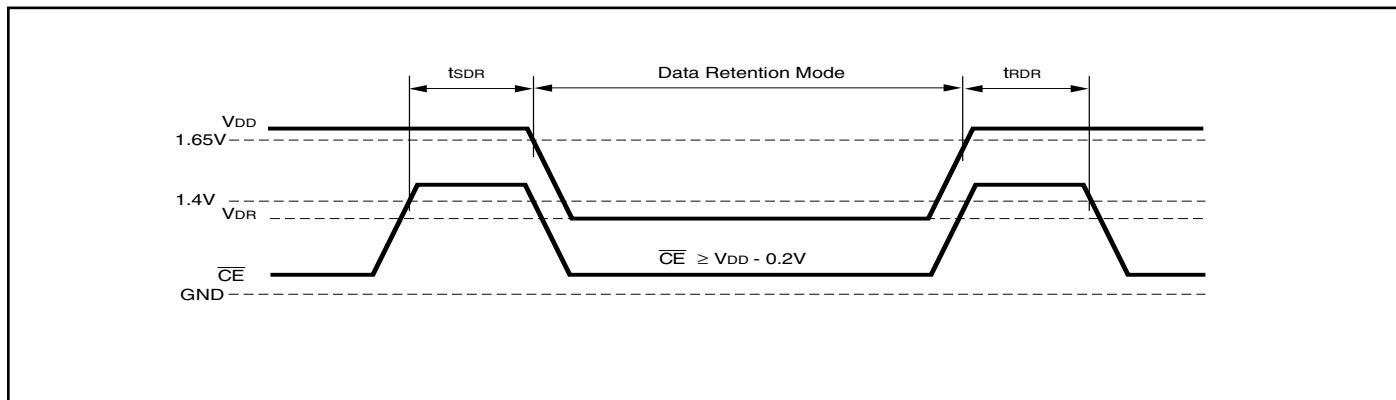

ORDERING INFORMATION
Industrial Range: -40°C to +85°C
Voltage Range: 2.4V to 3.6V

Speed (ns)	Order Part No.	Package
10 (8 ¹)	IS61WV20488BLL-10MI	48 mini BGA (9mm x 11mm)
	IS61WV20488BLL-10MLI	48 mini BGA (9mm x 11mm), Lead-free
	IS61WV20488BLL-10TI	TSOP (Type II)
	IS61WV20488BLL-10TLI	TSOP (Type II), Lead-free

Note:

 1. Speed = 8ns for V_{DD} = 3.3V ± 5%. Speed = 10ns for V_{DD} = 2.4V to 3.3V.

Industrial Range: -40°C to +85°C
Voltage Range: 1.65V to 2.2V

Speed (ns)	Order Part No.	Package
20	IS61WV20488ALL-20MI	48 mini BGA (9mm x 11mm)
	IS61WV20488ALL-20TI	TSOP (Type II)

Automotive Range: -40°C to +125°C
Voltage Range: 2.4V to 3.6V

Speed (ns)	Order Part No.	Package
10	IS64WV20488BLL-10MA3	48 mini BGA (9mm x 11mm)
	IS64WV20488BLL-10MLA3	48 mini BGA (9mm x 11mm), Lead-free
	IS64WV20488BLL-10TA3	TSOP (Type II)

SYM.	DIMENSION (mm)			DIMENSION (INCH)		
	MIN.	NOM.	MAX.	MIN.	NOM.	MAX.
A	—	—	1.20	—	—	0.047
A1	0.20	—	0.30	0.008	—	0.012
b	0.30	0.35	0.40	0.012	0.014	0.016
D	10.90	11.00	11.10	0.429	0.433	0.437
D1	5.25	BSC	—	0.207	BSC	—
E	8.90	9.00	9.10	0.350	0.354	0.358
E1	—	3.75	BSC	—	0.148	BSC
Ⓜ	—	0.75	BSC	—	0.030	BSC

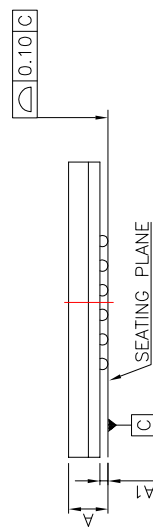
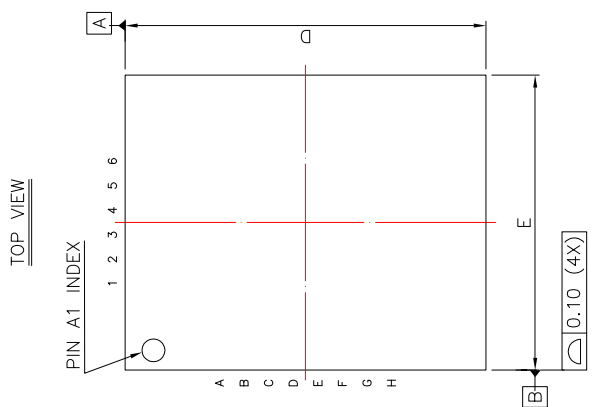
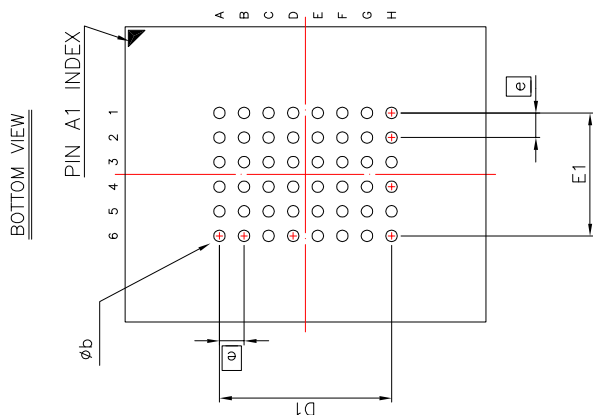

NOTE :

1. CONTROLLING DIMENSION : MM.
2. Reference document : JEDEC MO-207

	TITLE	48L 9x11mm TF-BGA Package Outline	REV.	B	DATE	08/21/2008
--	-------	-----------------------------------	------	---	------	------------

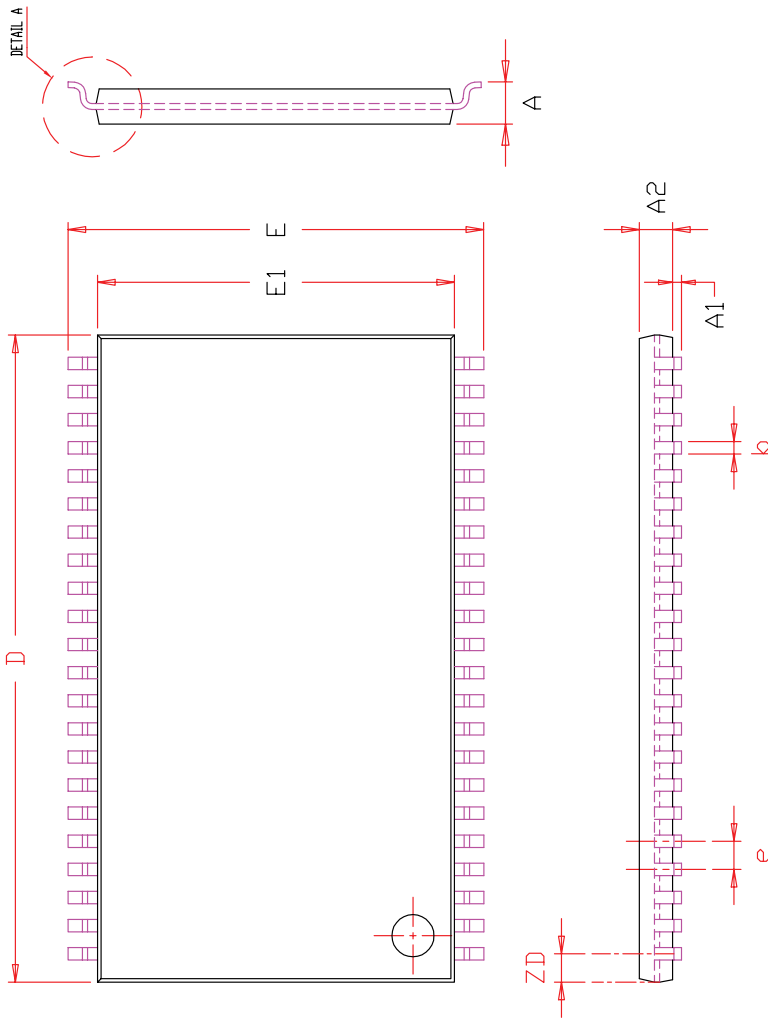

SYMBOL	DIMENSION IN MM			DIMENSION IN INCH		
	MIN.	NOM.	MAX.	MIN.	NOM.	MAX.
A	1.00		1.20	0.039		0.047
A1	0.05		0.15	0.002		0.006
A2	0.95	1.00	1.05	0.037	0.039	0.041
b	0.30		0.45	0.012		0.018
D	18.28	18.41	18.54	0.720	0.725	0.730
E	11.56	11.76	11.96	0.455	0.463	0.471
E1	10.03	10.16	10.29	0.395	0.400	0.405
e	0.80 BSC.			0.031 BSC.		
L	0.40		0.69	0.016		0.027
L1	0.25 BSC.			0.010 BSC.		
ZD	0.805 REF.			0.032 REF.		
⊕	0		8°	0		8°

NOTE :

1. CONTROLLING DIMENSION : MM
2. DIMENSION D AND E1 DO NOT INCLUDE MOLD PROTRUSION.
3. DIMENSION b DOES NOT INCLUDE DAMBAR PROTRUSION/INTRUSION.

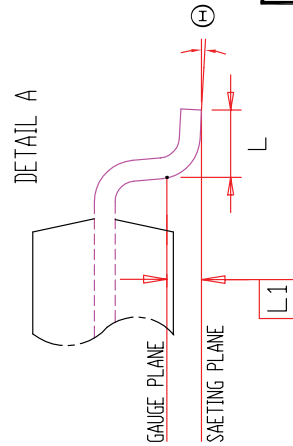

TITLE

44L 400mil TSOP-2
Package Outline

REV.

F

DATE

06/04/2008

Компания «Океан Электроники» предлагает заключение долгосрочных отношений при поставках импортных электронных компонентов на взаимовыгодных условиях!

Наши преимущества:

- Поставка оригинальных импортных электронных компонентов напрямую с производств Америки, Европы и Азии, а так же с крупнейших складов мира;
- Широкая линейка поставок активных и пассивных импортных электронных компонентов (более 30 млн. наименований);
- Поставка сложных, дефицитных, либо снятых с производства позиций;
- Оперативные сроки поставки под заказ (от 5 рабочих дней);
- Экспресс доставка в любую точку России;
- Помощь Конструкторского Отдела и консультации квалифицированных инженеров;
- Техническая поддержка проекта, помощь в подборе аналогов, поставка прототипов;
- Поставка электронных компонентов под контролем ВП;
- Система менеджмента качества сертифицирована по Международному стандарту ISO 9001;
- При необходимости вся продукция военного и аэрокосмического назначения проходит испытания и сертификацию в лаборатории (по согласованию с заказчиком);
- Поставка специализированных компонентов военного и аэрокосмического уровня качества (Xilinx, Altera, Analog Devices, Intersil, Interpoint, Microsemi, Actel, Aeroflex, Peregrine, VPT, Syfer, Eurofarad, Texas Instruments, MS Kennedy, Miteq, Cobham, E2V, MA-COM, Hittite, Mini-Circuits, General Dynamics и др.);

Компания «Океан Электроники» является официальным дистрибьютором и эксклюзивным представителем в России одного из крупнейших производителей разъемов военного и аэрокосмического назначения «**JONHON**», а так же официальным дистрибьютором и эксклюзивным представителем в России производителя высокотехнологичных и надежных решений для передачи СВЧ сигналов «**FORSTAR**».



JONHON

«**JONHON**» (основан в 1970 г.)

Разъемы специального, военного и аэрокосмического назначения:

(Применяются в военной, авиационной, аэрокосмической, морской, железнодорожной, горно- и нефтедобывающей отраслях промышленности)

«**FORSTAR**» (основан в 1998 г.)

ВЧ соединители, коаксиальные кабели, кабельные сборки и микроволновые компоненты:

(Применяются в телекоммуникациях гражданского и специального назначения, в средствах связи, РЛС, а так же военной, авиационной и аэрокосмической отраслях промышленности).



Телефон: 8 (812) 309-75-97 (многоканальный)

Факс: 8 (812) 320-03-32

Электронная почта: ocean@oceanchips.ru

Web: <http://oceanchips.ru/>

Адрес: 198099, г. Санкт-Петербург, ул. Калинина, д. 2, корп. 4, лит. А