

CJ series Position Control Units

CJ1W-NC□□3

CSM_CJ1W-NC_DS_E_8_3

High-speed, High-precision positioning with 1, 2, or 4 axes

- Versatile functions and superb performance enable the construction of compact, high-performance machines.
- With its ultra-compact size of 31 × 90 mm (W × H), this highly space-efficient Position Control Unit (PCU) enables up to 4 axes of motor control.



Features

- Two types to choose from: open collector output and line driver. Because both open collector output and line driver types feature 1-, 2-, and 4-axis models, the most appropriate model can be selected for the application at hand.
- Positioning START occurs within 2 ms (maximum speed) after receiving a command from the Programmable Controller. (Refer to the Operation Manual for conditions.)
- High-speed data transfer is possible using INTELLIGENT I/O WRITE (IOWR) and INTELLIGENT I/O READ (IORD) instructions.
- Fine control from low to high speed (500 kpps max.) is possible in 1-pps units.
- Positioning can be done from memory, by writing an operating pattern into the PCU memory in advance. Three position patterns – Terminating, Automatic, and Continuous – can be set with completion codes to respond to a wide range of operations. Positioning of up to 100 patterns (sequential data) per one axis can be possible.
- Positioning (direct operation) can be done by direct PLC ladder commands for position data, speed data, and acceleration data. This simplifies control in situations when the target position and speed cannot be decided until immediately before operation begins, or when the target position and speed change due to other circumstances. The target position and speed can also be changed during operation.
- Interrupt feeding moves the axis a specified amount, then stops it, in accordance with an interrupt input. High-speed (0.1 ms max.) processing of the interrupt input signal ensures high-precision interrupt positioning. This helps to maximize feeder precision.
- Easy-to-Use positioning can be possible with versatile functions such as Teaching, Override, Backlash compensation, Zones, Forced interrupt and Acceleration/Deceleration curve.

System Configuration

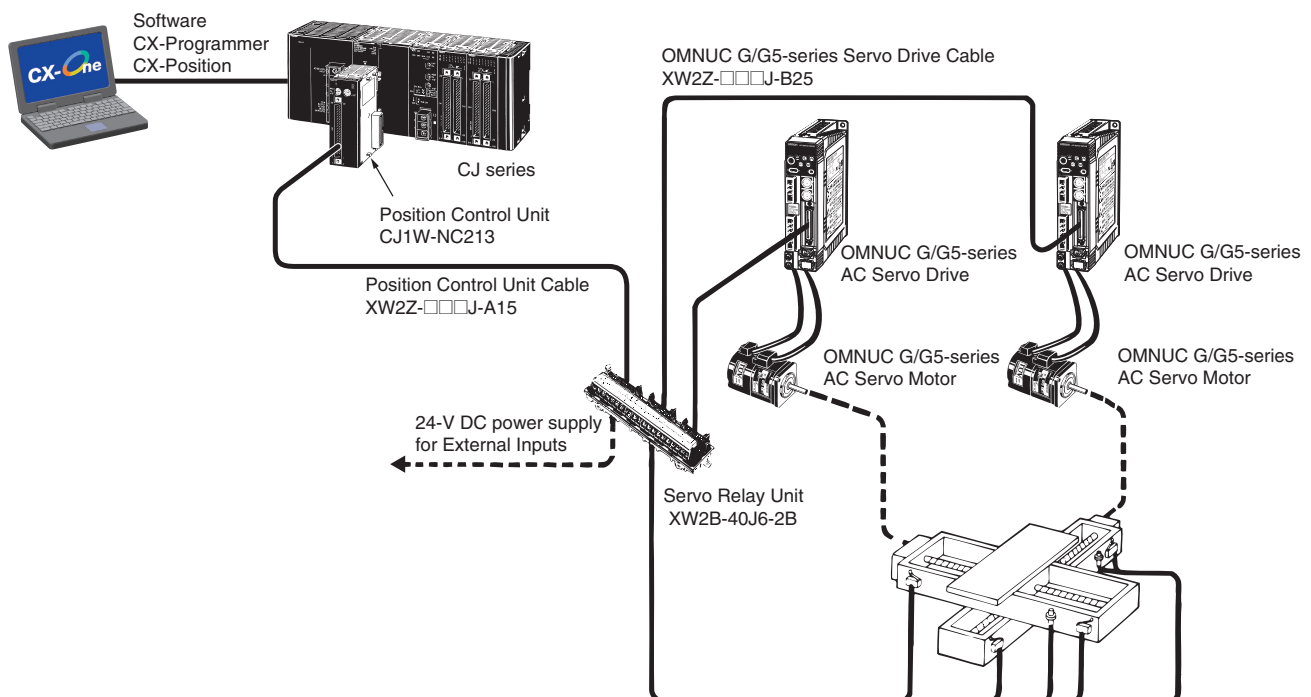

Ordering Information

International Standards

- The standards are abbreviated as follows: U: UL, U1: UL(Class I Division 2 Products for Hazardous Locations), C: CSA, UC: cULus, UC1: cULus (Class I Division 2 Products for Hazardous Locations), CU: cUL, N: NK, L: Lloyd, and CE: EC Directives.
- Contact your OMRON representative for further details and applicable conditions for these standards.

Position Control Unit

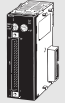
Unit type	Name	Specifications		No. of unit numbers allocated	Current consumption (A)		Model	Standards
		Control method/Control output interface	Number of control axes		5 V system	24 V system		
CJ1 Special I/O Units	Position control unit 	Open-loop control by pulse train output/ Open-collector output	1 axis	1	0.25	–	CJ1W-NC113	UC1, CE
			2 axes		0.25	–	CJ1W-NC213	
			4 axes *	2	0.36	–	CJ1W-NC413	
		Open-loop control by pulse train output/ Line-driver output	1 axis	1	0.25	–	CJ1W-NC133	
			2 axes		0.25	–	CJ1W-NC233	
	4 axes *		2	0.36	–	CJ1W-NC433		
Space Unit	The ambient operation temperature range can be increased to 0 to 55°C if the CJ1W-SP001 CJ-series Space Unit is used.					CJ1W-SP001	UC1, CE	

Note: This unit cannot be used with the Machine Automation Controller NJ-series.

* The ambient operating temperature of the CJ1W-NC413/NC433 is 0 to 50°C. Allowable power supply voltage range for external power supply is 22.8 to 25.2 V DC.

Software

Name	Specifications	Number of licenses	Model	Standards
FA Integrated Tool Package CX-One Ver. 4. □	The CX-One is a comprehensive software package that integrates Support Software for OMRON PLCs and components. CX-One runs on the following OS. OS: Windows XP (Service Pack 3 or higher, 32-bit version) / Windows Vista (32-bit/64-bit version) / Windows 7 (32-bit/64-bit version) / Windows 8 (32-bit/64-bit version) / Windows 8.1 (32-bit/64-bit version) / Windows 10 (32-bit/64-bit version) CX-One Ver.4. □ includes CX-Position Ver.2. □. For details, refer to the CX-One catalog (Cat. No.R134).	1 license * DVD	CXONE-AL01D-V4	–

* Multi licenses (3, 10, 30, or 50 licenses) and DVD media without licenses are also available for the CX-One.





Servo Relay Unit/Cables

Name	Applicable units	Applicable drives	Number of control axes	Cable length	Model	Standards
Servo Relay Unit	For CJ1W-NC113/133 (No communication supported)	–	1 axis	–	XW2B-20J6-1B	–
	For CJ1W-NC213/233/413/433 (No communication supported)	–	2 axes	–	XW2B-40J6-2B	–
	For CJ1W-NC113/133/213/233/413/433 (Communication supported)	–	2 axes	–	XW2B-40J6-4A	–
Position Control Unit Cables for Servo Relay Unit	Open-collector output	For CJ1W-NC113	1 axis	0.5m	XW2Z-050J-A14	–
				1m	XW2Z-100J-A14	
				0.5m	XW2Z-050J-A16	
		1m	XW2Z-100J-A16			
		For CJ1W-NC213/413	2 axes	0.5m	XW2Z-050J-A15	
				1m	XW2Z-100J-A15	
	0.5m			XW2Z-050J-A17		
	1m	XW2Z-100J-A17				
	Line-driver output	For CJ1W-NC313	1 axis	0.5m	XW2Z-050J-A18	
				1m	XW2Z-100J-A18	
				0.5m	XW2Z-050J-A20	
		1m	XW2Z-100J-A20			
For CJ1W-NC233/413		2 axes	0.5m	XW2Z-050J-A19		
			1m	XW2Z-100J-A19		
	0.5m		XW2Z-050J-A21			
1m	XW2Z-100J-A21					

Accessories

The Position Control Unit includes the 40-pin solder-type connectors C500-CE404 (socket: Fujitsu FCN-361J040-AU, cover: Fujitsu FCN-360C040-J2).

Applicable Connectors

Name	Specifications	Model
External I/O Connectors	 40 pin, soldered, right angle w/cover (included with the Unit)	C500-CE404
	 40 pin, crimped right angle w/cover	C500-CE405
	 40 pin, Pressure welded, w/o cover	C500-CE403
	 40 pin, soldered, w/cover	C500-CE401
	 40 pin, crimped w/cover	C500-CE402

Mountable Racks

Model	NJ system		CJ system (CJ1, CJ2)		CP1H system	NSJ system	
	CPU Rack	Expansion Rack	CPU Rack	Expansion Backplane	CP1H PLC	NSJ Controller	Expansion Backplane
CJ1W-NC113/133/213/233/413/433	Not supported		10 Units	10 Units (per Expansion Backplane)	2 Units *	Not Supported	8 Units

* CJ Unit Adapter CP1W-EXT01 required.

Specifications

Basic Specifications

Item	Model		
	CJ1W-NC113/133	CJ1W-NC213/233	CJ1W-NC413/433
Power supply voltage	5 V DC (for the PCU itself)		
	24 V DC (external power supply)		
	5 V DC (external power supply; line driver output only)		
Allowable power supply voltage range	4.75 to 5.25 V DC (for the PCU itself)		
	21.6 to 26.4 V DC (external power supply)		22.8 to 25.2 V DC (external power supply)
	4.75 to 5.25 V DC (external power supply; line driver output only)		
Internal current consumption	250 mA max. at 5 V DC	250 mA max. at 5 V DC	360 mA max. at 5 V DC
Current consumption of external power supply	NC113: 30 mA max. at 24 V DC NC133: 10 mA max. at 24 V DC NC133: 60 mA max. at 5 V DC	NC213: 50 mA max. at 24 V DC NC233: 20 mA max. at 24 V DC NC233: 120 mA max. at 5 V DC	NC413: 100 mA max. at 24 V DC NC433: 30 mA max. at 24 V DC NC433: 230 mA max. at 5 V DC
External dimensions	90 (H) × 31 (W) × 65 (D) (all models)		
Weight	100 g max.	100 g max.	150 g max.
Ambient operating temperature	0 to 55°C		0 to 50°C *

Note: Specifications not listed above conform to CJ Series general specifications.

* Refer to Operation Manual 3-3-5 *Mounting Precaution for CJ1W-NC413/NC433* for information on the ambient operating temperature of the CJ1W-NC413/433.

Performance Specifications

Item	Model			
	CJ1W-NC113/133	CJ1W-NC213/233	CJ1W-NC413/433	
Applicable PLC models	CJ-series PLCs *1			
Unit type	Special I/O Unit			
I/O requirements	Words	5 words	10 words	20 words
Controlled driver	Pulse-train input-type Servo Drive or stepping motor driver NC113/213/413 models have open collector output. NC133/233/433 models have line driver output.			
Control	Control system	Open-loop control by pulse train output		
	Number of control axes	1 axis	2 axes	4 axes
Control unit	Pulse			
Positioning operations	Two types: memory operation and direct operation			
	Independent	1 axis	2 independent axes	4 independent axes
	Linear interpolation	None	2 axes max.	4 axes max.
	Speed control	1 axis	2 independent axes	4 independent axes
	Interrupt feeding	1 axis	2 independent axes	4 independent axes
Positions	Range	-1,073,741,823 to 1,073,741,823 pulses *2		
	Data items	100/axis		
Speeds	Range	1 pps to 500 kpps		
	Data items	100/axis		
Acceleration and deceleration times	Range	0 to 250 s, until maximum speed is reached.		
	Data items	9/axis for acceleration and deceleration each		
Functions and settings	Origin search	Origin proximity input signal: selectable (absent, N.O. or N.C. contact). Origin input signal: selectable (N.O. or N.C. contact) Origin compensation: -1,073,741,823 to 1,073,741,823 pulses Origin search speed: High-speed or proximity-speed can be set. Origin detection method: May be set to stop upon origin input signal after proximity input signal has turned ON, to stop upon origin input signal after proximity input signal has turned OFF, to stop upon origin input signal without using proximity input signal, or to stop upon origin input signal after limit input signal has turned OFF. N.O. = Normally open N.C. = Normally closed		
	Jogging	Jogging can be executed at a specified speed.		
	Dwell times	19/axis can be set from 0 to 9.99 s (unit: 0.01 s).		
	Acceleration/ deceleration curves	Trapezoidal or S-curve (Can be set separately for each axis.)		
Functions and settings	Zones	Zone Flag turns ON when present position is within a specified zone. Three zones can be set for each axis.		
	Software limits	Can be set within a range of -1,073,741,823 to 1,073,741,823 pulses.		
	Backlash compensation	0 to 9,999 pulses. Compensation speed can also be set.		
	Teaching	With a command from the PLC, the present position can be taken as the position data.		
	Deceleration stop	The STOP command causes positioning to decelerate to a stop according to the specified deceleration time.		
	Emergency stop	Pulse outputs are stopped by an external emergency stop command.		
	Present position preset	The PRESENT POSITION PRESET command can be used to change the present position to a specified value.		
	Override	When the override enabling command is executed during positioning, the target speed is changed by applying the override coefficient. Possible to set to a value from 1 to 999% (by an increment of 1%)		
External I/O	Inputs	Prepare the following inputs for each axis: CW and CCW limit input signals, origin proximity input signal, origin input signal, emergency stop input signal, positioning completed signal, interrupt input signal		
	Outputs	Prepare the following outputs for each axis: Pulse outputs CW/CCW pulses, pulse outputs and direction outputs can be switched. Either error counter reset or origin-adjustment command outputs can be selected depending on the mode.		
Pulse output distribution period	1-axis operation: 4 ms Linear interpolation: 8 ms			
Response time	Refer to Operation manual <i>Appendix A Performance Characteristics</i> .			
Self-diagnostic function	Flash memory check, memory loss check, CPU bus check			
Error detection function	Overtravel, CPU error, software limit over, emergency stop			

*1. The additional functions supported by unit version 2.0 can be used only when the PCU is installed with a CJ1-H or CJ1M CPU Unit (either CPU Unit Ver. 2.0 or Pre-Ver. 2.0 CPU Unit). These functions cannot be used if the PCU is installed with a CJ1 CPU Unit.
For details on Unit versions, refer to *Unit Versions of CJ-series Position Control Units* on Operation manual page vi.

*2. When performing linear interpolation, the distances that can be moved will vary.

External Interface

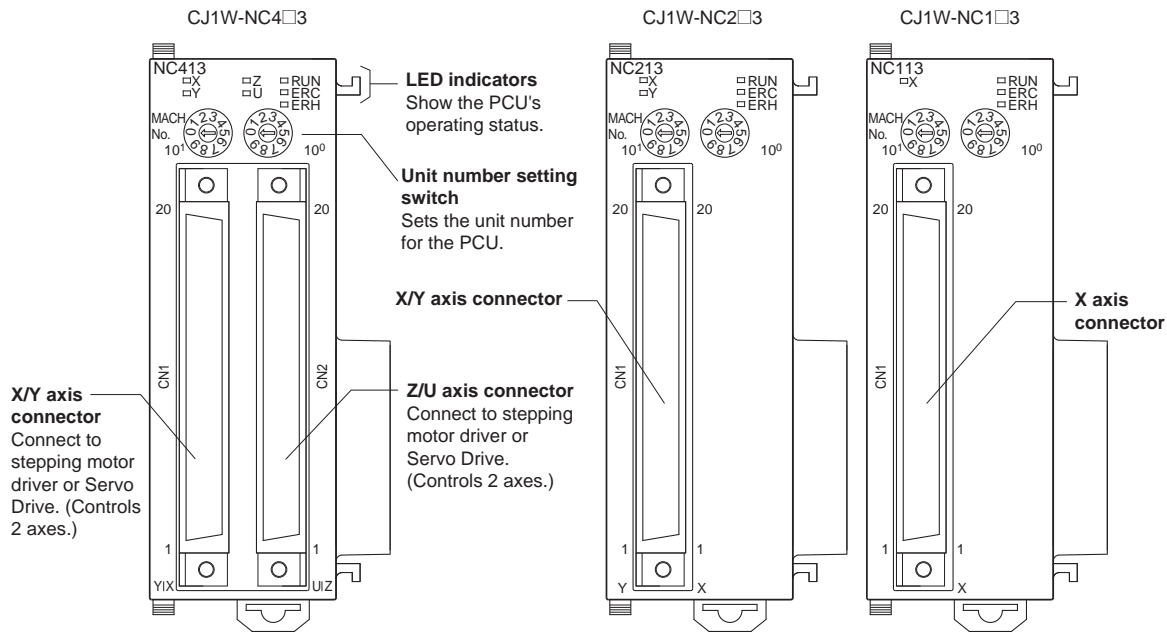

LED Indicators

Name	Color	Status	Explanation
RUN	Green	Lit	Lit during normal operation.
		Not lit	Hardware error, or PLC notified of PCU error.
ERC	Red	Lit	An error has occurred.
		Not lit	No error has occurred.
ERH	Red	Lit	An error has occurred IN the CPU Unit.
		Not lit	No error has occurred at the CPU Unit.
X	Orange	Lit	Pulses are being output to the X axis (either forward or reverse).
		Flashing	An error has occurred, such as incorrect cable type for the X axis or faulty data.
		Not lit	None of the above has occurred.
Y	Orange	Lit	Pulses are being output to the Y axis (either forward or reverse).
		Flashing	An error has occurred, such as incorrect cable type for the Y axis or faulty data.
		Not lit	None of the above has occurred.
Z	Orange	Lit	Pulses are being output to the Z axis (either forward or reverse).
		Flashing	An error has occurred, such as incorrect cable type for the Z axis or faulty data.
		Not lit	None of the above has occurred.
U	Orange	Lit	Pulses are being output to the U axis (either forward or reverse).
		Flashing	An error has occurred, such as incorrect cable type for the U axis or faulty data.
		Not lit	None of the above has occurred.

Note 1. For the CJ1W-NC113/NC133, this applies only to the X axis; for the CJ1W-NC213/NC233, it applies only to the X and Y axes.

Note 2. When not all of the axes are used for the CJ1W-NC213/NC233/ NC413/NC433, either connect the CW/CCW limit inputs for the unused axes to the input power supply and turn them ON or set the contact logic to N.O. Connect the emergency stop to the input common and turn it ON. If it is not connected, the ERC indicator will light. Operation will be normal, however, for all axes that are used.

Functions Supported by Each Unit Version of Position Control Unit

Unit Version		Pre-Ver. 2.0	Ver. 2.0	Ver. 2.3
Internal system software version		1.0	2.0	2.3
CJ-series Position Control Units		CJ1W-NC113/133/213/233/413/433		
Functions	Changing the acceleration for a multiple start during relative movement or absolute movement in direct operation	Not supported	Supported	Supported
	Changing acceleration/deceleration time during jog operation	Not supported	Supported	Supported
	Setting acceleration/deceleration time for axis parameters until the target speed is reached	Not supported	Supported	Supported
	Easy backup function	Not supported	Supported	Supported
	Setting number of unused axes	Not supported	Not supported	Supported
	Setting CW/CCW pulse output direction	Not supported	Not supported	Supported
	Setting origin search pattern	Not supported	Not supported	Supported
	Position data setting when origin signal stops	Not supported	Not supported	Supported
	Setting jog operation	Not supported	Not supported	Supported
	Setting deviation counter reset output signal	Not supported	Not supported	Supported
Checking parameters and data at startup	Not supported	Not supported	Supported	
Support Software	CX-Position Ver. 1.0 or later	CX-Position Ver. 1.0 *1 CX-Position Ver. 2.0 or later	CX-Position Ver. 1.0 *1 CX-Position Ver. 2.0 *2 CX-Position Ver. 2.1 *2 CX-Position Ver. 2.2 or later	

Note: The Position Control Unit must be installed with CJ1-H or CJ1M CPU Unit to use the above functions supported for Position Control Unit Ver. 2.0. These functions cannot be used if the Position Control Unit is installed with a CJ1 CPU Unit.

*1. With CX-Position Ver. 1.0, new functions added to Position Control Units Ver. 2.0 or higher cannot be used.

*2. With CX-Position Ver. 2.0 and CX-Position Ver. 2.1, new functions added to Position Control Units Ver. 2.3 or higher cannot be used.

Connecting Connectors Using Servo Relay Units

Wiring requires the dedicated cables.
 Position Control Unit Cables, Servo Relay Unit, Servo Drive Cable are sold separately.

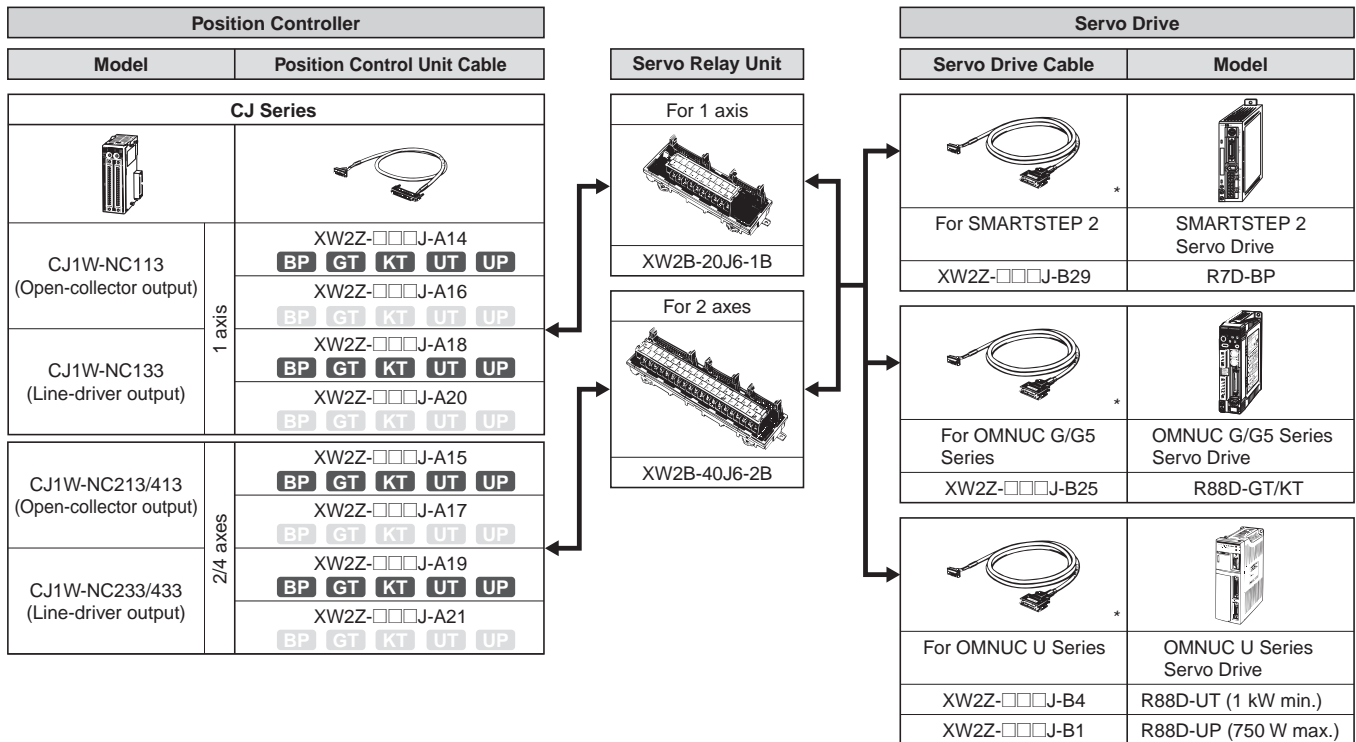

The following icons represents applicable servo drives.

- BP** : SMARTSTEP2
- GT** : OMNUC G Series
- KT** : OMNUC G5 Series
- UT** : OMNUC U Series (1 kW min.)
- UP** : OMNUC U Series (750 W max.)

* Two Servo Drive Cables are required if 2-axis control is performed using one Position Control Unit.

Dimensions

CJ1W-NC113/213/413
NC133/233/433

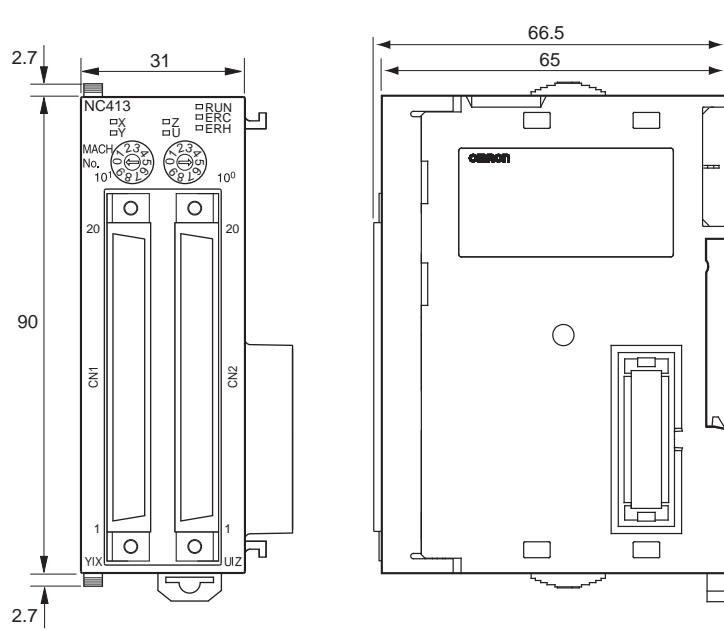

Note: The above diagram is for the CJ1W-NC413.

Mounted Dimensions

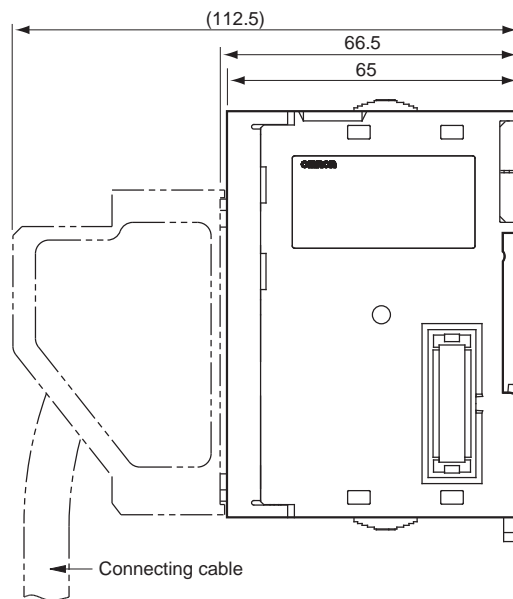

CJ1W-SP001

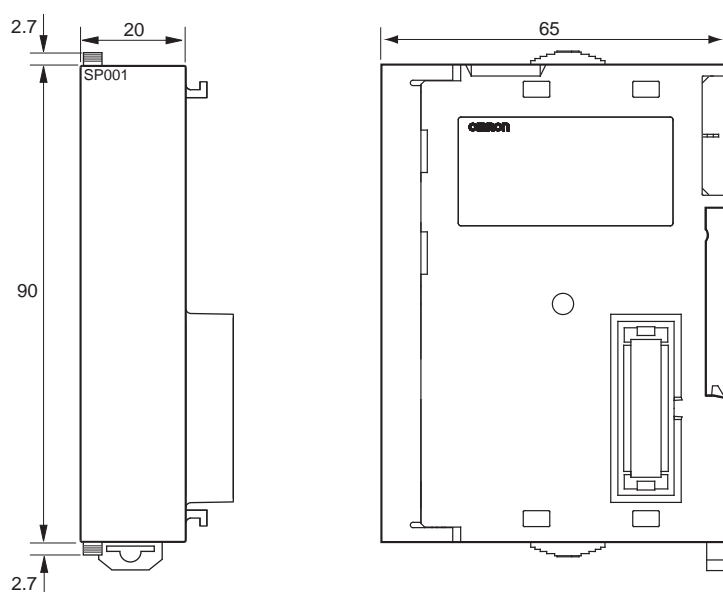

Related Manuals

Manual number		Model	Name	Contents
English	Japanese			
W397	SBCE-315	CJ1W-NC113/133/213/233/413/433	Position Control Units Operation Manual	Provides information on operating and installing Position Control Units, including details on basic settings, memory operation, direct operation from CPU and other functions.
W433	SBCE-324	CXONE-AL□□D-V□	CX-Position Operation Manual	Provides an overview of CX-Position, its functions, and the system configuration, installation, and troubleshooting.

Terms and Conditions Agreement

Read and understand this catalog.

Please read and understand this catalog before purchasing the products. Please consult your OMRON representative if you have any questions or comments.

Warranties.

(a) Exclusive Warranty. Omron's exclusive warranty is that the Products will be free from defects in materials and workmanship for a period of twelve months from the date of sale by Omron (or such other period expressed in writing by Omron). Omron disclaims all other warranties, express or implied.

(b) Limitations. OMRON MAKES NO WARRANTY OR REPRESENTATION, EXPRESS OR IMPLIED, ABOUT NON-INFRINGEMENT, MERCHANTABILITY OR FITNESS FOR A PARTICULAR PURPOSE OF THE PRODUCTS. BUYER ACKNOWLEDGES THAT IT ALONE HAS DETERMINED THAT THE PRODUCTS WILL SUITABLY MEET THE REQUIREMENTS OF THEIR INTENDED USE.

Omron further disclaims all warranties and responsibility of any type for claims or expenses based on infringement by the Products or otherwise of any intellectual property right. (c) Buyer Remedy. Omron's sole obligation hereunder shall be, at Omron's election, to (i) replace (in the form originally shipped with Buyer responsible for labor charges for removal or replacement thereof) the non-complying Product, (ii) repair the non-complying Product, or (iii) repay or credit Buyer an amount equal to the purchase price of the non-complying Product; provided that in no event shall Omron be responsible for warranty, repair, indemnity or any other claims or expenses regarding the Products unless Omron's analysis confirms that the Products were properly handled, stored, installed and maintained and not subject to contamination, abuse, misuse or inappropriate modification. Return of any Products by Buyer must be approved in writing by Omron before shipment. Omron Companies shall not be liable for the suitability or unsuitability or the results from the use of Products in combination with any electrical or electronic components, circuits, system assemblies or any other materials or substances or environments. Any advice, recommendations or information given orally or in writing, are not to be construed as an amendment or addition to the above warranty.

See <http://www.omron.com/global/> or contact your Omron representative for published information.

Limitation on Liability; Etc.

OMRON COMPANIES SHALL NOT BE LIABLE FOR SPECIAL, INDIRECT, INCIDENTAL, OR CONSEQUENTIAL DAMAGES, LOSS OF PROFITS OR PRODUCTION OR COMMERCIAL LOSS IN ANY WAY CONNECTED WITH THE PRODUCTS, WHETHER SUCH CLAIM IS BASED IN CONTRACT, WARRANTY, NEGLIGENCE OR STRICT LIABILITY.

Further, in no event shall liability of Omron Companies exceed the individual price of the Product on which liability is asserted.

Suitability of Use.

Omron Companies shall not be responsible for conformity with any standards, codes or regulations which apply to the combination of the Product in the Buyer's application or use of the Product. At Buyer's request, Omron will provide applicable third party certification documents identifying ratings and limitations of use which apply to the Product. This information by itself is not sufficient for a complete determination of the suitability of the Product in combination with the end product, machine, system, or other application or use. Buyer shall be solely responsible for determining appropriateness of the particular Product with respect to Buyer's application, product or system. Buyer shall take application responsibility in all cases.

NEVER USE THE PRODUCT FOR AN APPLICATION INVOLVING SERIOUS RISK TO LIFE OR PROPERTY OR IN LARGE QUANTITIES WITHOUT ENSURING THAT THE SYSTEM AS A WHOLE HAS BEEN DESIGNED TO ADDRESS THE RISKS, AND THAT THE OMRON PRODUCT(S) IS PROPERLY RATED AND INSTALLED FOR THE INTENDED USE WITHIN THE OVERALL EQUIPMENT OR SYSTEM.

Programmable Products.

Omron Companies shall not be responsible for the user's programming of a programmable Product, or any consequence thereof.

Performance Data.

Data presented in Omron Company websites, catalogs and other materials is provided as a guide for the user in determining suitability and does not constitute a warranty. It may represent the result of Omron's test conditions, and the user must correlate it to actual application requirements. Actual performance is subject to the Omron's Warranty and Limitations of Liability.

Change in Specifications.

Product specifications and accessories may be changed at any time based on improvements and other reasons. It is our practice to change part numbers when published ratings or features are changed, or when significant construction changes are made. However, some specifications of the Product may be changed without any notice. When in doubt, special part numbers may be assigned to fix or establish key specifications for your application. Please consult with your Omron's representative at any time to confirm actual specifications of purchased Product.

Errors and Omissions.

Information presented by Omron Companies has been checked and is believed to be accurate; however, no responsibility is assumed for clerical, typographical or proofreading errors or omissions.

Mouser Electronics

Authorized Distributor

Click to View Pricing, Inventory, Delivery & Lifecycle Information:

Omron:

[CJ1W-SP001](#) [CJ1W-NC213](#) [CJ1W-NC113](#) [CJ1W-NC133](#) [CJ1W-NC233](#) [CJ1W-NC413](#) [CJ1W-NC433](#)

Компания «Океан Электроники» предлагает заключение долгосрочных отношений при поставках импортных электронных компонентов на взаимовыгодных условиях!

Наши преимущества:

- Поставка оригинальных импортных электронных компонентов напрямую с производств Америки, Европы и Азии, а так же с крупнейших складов мира;
- Широкая линейка поставок активных и пассивных импортных электронных компонентов (более 30 млн. наименований);
- Поставка сложных, дефицитных, либо снятых с производства позиций;
- Оперативные сроки поставки под заказ (от 5 рабочих дней);
- Экспресс доставка в любую точку России;
- Помощь Конструкторского Отдела и консультации квалифицированных инженеров;
- Техническая поддержка проекта, помощь в подборе аналогов, поставка прототипов;
- Поставка электронных компонентов под контролем ВП;
- Система менеджмента качества сертифицирована по Международному стандарту ISO 9001;
- При необходимости вся продукция военного и аэрокосмического назначения проходит испытания и сертификацию в лаборатории (по согласованию с заказчиком);
- Поставка специализированных компонентов военного и аэрокосмического уровня качества (Xilinx, Altera, Analog Devices, Intersil, Interpoint, Microsemi, Actel, Aeroflex, Peregrine, VPT, Syfer, Eurofarad, Texas Instruments, MS Kennedy, Miteq, Cobham, E2V, MA-COM, Hittite, Mini-Circuits, General Dynamics и др.);

Компания «Океан Электроники» является официальным дистрибьютором и эксклюзивным представителем в России одного из крупнейших производителей разъемов военного и аэрокосмического назначения «JONHON», а так же официальным дистрибьютором и эксклюзивным представителем в России производителя высокотехнологичных и надежных решений для передачи СВЧ сигналов «FORSTAR».



JONHON

«JONHON» (основан в 1970 г.)

Разъемы специального, военного и аэрокосмического назначения:

(Применяются в военной, авиационной, аэрокосмической, морской, железнодорожной, горно- и нефтедобывающей отраслях промышленности)

«FORSTAR» (основан в 1998 г.)

ВЧ соединители, коаксиальные кабели,
кабельные сборки и микроволновые компоненты:

(Применяются в телекоммуникациях гражданского и специального назначения, в средствах связи, РЛС, а так же военной, авиационной и аэрокосмической отраслях промышленности).



Телефон: 8 (812) 309-75-97 (многоканальный)

Факс: 8 (812) 320-03-32

Электронная почта: ocean@oceanchips.ru

Web: <http://oceanchips.ru/>

Адрес: 198099, г. Санкт-Петербург, ул. Калинина, д. 2, корп. 4, лит. А