

4.0W CLASS-G AUDIO AMPLIFIER WITH INTEGRATED BOOST CONVERTER AND BATTERY TRACKING AGC
NEW PRODUCT
Description

The PAM8945 is a high efficiency Class-G audio power amplifier with an integrated boost converter. It drives up to 4.0W (10% THD+N) into a 4Ω speaker. With 85% typical efficiency, the PAM8945 helps extend battery life when playing audio.

The built-in boost converter generates the voltage rail for the output stage. This provides a louder audio output than a stand-alone amplifier connected directly to the battery. It also maintains a consistent loudness, regardless of battery voltage.

The PAM8945 features battery tracking AGC function which adjusts the amplifier gain to limit battery current at lower battery voltage.

The PAM8945 features DC input protection and all outputs are fully protected against output-to-output shorts. The PAM8945 is available in tiny W-QFN3020-12 package.

Features

- Built-In Battery Tracking Automatic Gain Control (AGC)
- High Efficiency Integrated Boost Converter Over 85%
- 4.0W into a 4Ω Load at 10% THD
- 3.2W into a 4Ω Load at 1% THD
- Operates from 2.8V to 5.2V
- Efficient Class-G Prolongs Battery Life
- Minimized ON/OFF Pop Noise
- Superior Low Noise
- High PSRR
- DC Input Protection
- Auto-Recovery Short-Circuit Protection
- Thermal Shutdown
- Available in 2.0mm X 3.0mm 12L W-QFN Package
- **Totally Lead-Free & Fully RoHS Compliant (Notes 1 & 2)**
- **Halogen and Antimony Free. "Green" Device (Note 3)**

- Notes:
1. No purposely added lead. Fully EU Directive 2002/95/EC (RoHS) & 2011/65/EU (RoHS 2) compliant.
 2. See http://www.diodes.com/quality/lead_free.html for more information about Diodes Incorporated's definitions of Halogen- and Antimony-free, "Green" and Lead-free.
 3. Halogen- and Antimony-free "Green" products are defined as those which contain <900ppm bromine, <900ppm chlorine (<1500ppm total Br + Cl) and <1000ppm antimony compounds.

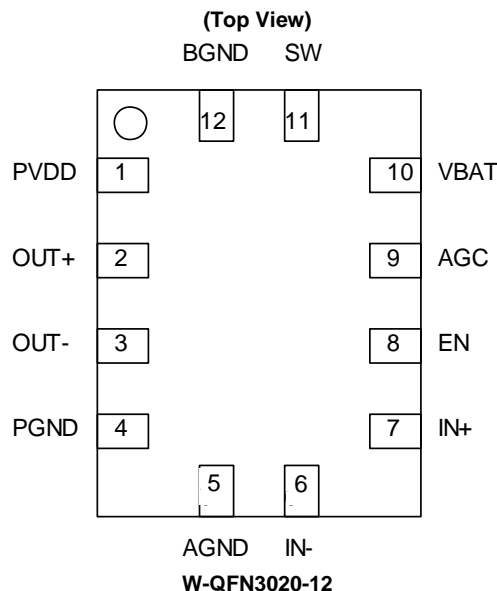
Pin Assignments

Applications

- Cell Phones
- PDA
- GPS
- Portable Electronics
- Speakers

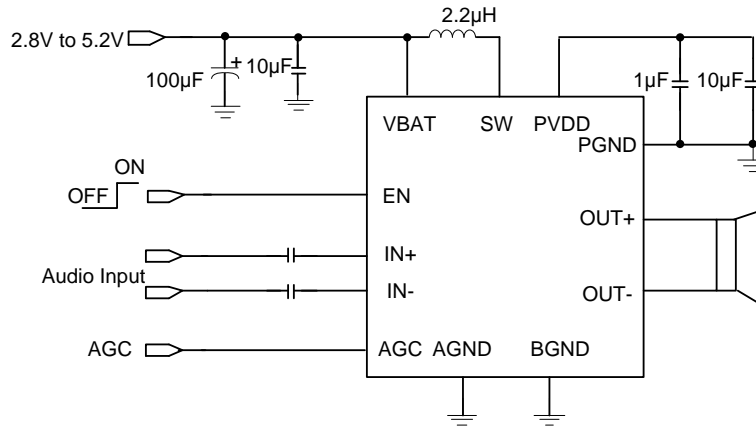
Typical Applications Circuit



Pin Descriptions

Pin Number	Pin Name	Description
1	PVDD	Boost Converter Output and Amplifier Power Supply
2	OUT+	Amplifier Positive Audio Output
3	OUT-	Amplifier Negative Audio Output
4	PGND	Power Ground
5	AGND	Analog Ground
6	IN-	Negative Audio Input
7	IN+	Positive Audio Input
8	EN	Shutdown Terminal for the Chip
9	AGC	AGC Setting Gain
10	VBAT	Supply Voltage
11	SW	Boost Converter Switching
12	BGND	Power Ground

NEW PRODUCT

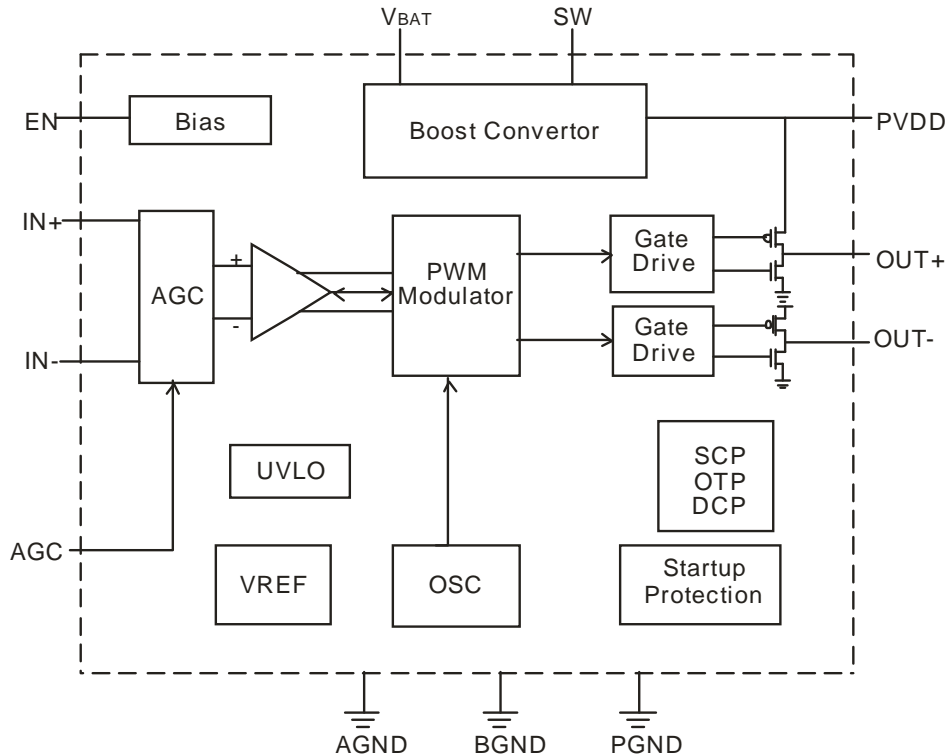
Functional Block Diagram

NEW PRODUCT
Absolute Maximum Ratings (@ $T_A = +25^\circ\text{C}$, unless otherwise specified.)

Symbol	Parameter	Value	Unit
V_{BAT}	Supply Voltage	-0.3 to 6.0	V
V_I	Input Voltage, EN, IN+, IN-, AGC	-0.3 to $V_{BAT} + 0.3$	V
T_A	Operating Free-air Temperature Range	-40 to +85	$^\circ\text{C}$
T_J	Operating Junction Temperature Range	-40 to +150	$^\circ\text{C}$
T_{STG}	Storage Temperature Range	-65 to +150	$^\circ\text{C}$

Recommended Operating Conditions (@ $T_A = +25^\circ\text{C}$, unless otherwise specified.)

Symbol	Parameter	Min	Max	Unit
V_{BAT}	Supply Voltage	2.8	5.2	V
V_{IH}	High-Level Input Voltage	EN	V_{BAT}	V
V_{IL}	Low-Level Input Voltage	EN	0.6	V
T_A	Operating Free-Air Temperature	-40	+85	$^\circ\text{C}$

Thermal Information

Symbol	Parameter	Package	Max	Unit
θ_{JA}	Thermal Resistance (Junction to Ambient)	W-QFN3020-12	62	$^\circ\text{C}/\text{W}$
θ_{Jc}	Thermal Resistance (Junction to Case)	W-QFN3020-12	11	

Electrical Characteristics (@V_{BAT}=3.6V, AGC=GND, T_A = +25°C, R_L=4Ω +33uH, unless otherwise specified.)

Symbol	Parameter	Test Conditions		Min	Typ	Max	Unit
V _{BAT}	Supply Voltage	—		2.8	—	5.2	V
P _O	Output Power	THD+N=10%, f=1kHz	V _{BAT} =3.6V	—	4.0	—	W
		THD+N=1%, f=1kHz		—	3.2	—	W
THD+N	Total Harmonic Distortion Plus Noise	P _O =1.0W, R _L =8Ω	f=1kHz	—	0.07	—	%
		P _O =2W, R _L =4Ω		—	0.15	—	
PSRR	Power Supply Ripple Rejection	V _{BAT} =3.6V, Input AC - ground with C=1μF	f=217Hz	—	70	—	dB
			f=1kHz	—	70	—	
			f=10kHz	—	67	—	
SNR	Signal-To-Noise Ratio	A-weighting	THD+N=1%	—	95	—	dB
V _{OP}	Peak Output Voltage	V _{BAT} =3.6V	f=1kHz	—	5.75	—	V
V _{O_TH}	Boost Convertor Auto-Pass Through Threshold	—	—	—	2	—	V(Peak)
V _N	Output Noise	Input AC-ground	No A-weighting	—	100	—	μV
			A-weighting	—	60	—	
η	Efficiency	R _L =8Ω, P _O =1W	f=1kHz	—	86	—	%
I _Q	Quiescent Current	V _{BAT} =3.6V	No Load	—	4	—	mA
I _{SD}	Shutdown Current	V _{BAT} =2.8V to 5.2V	EN=0V	—	—	1	μA
R _{DS(ON)}	Static Drain-to-Source On-State Resistor	High Side PMOS, I=500mA	V _{BAT} =5V	—	260	—	mΩ
		Low Side NMOS, I=500mA	V _{BAT} =5V	—	160	—	mΩ
f _{SW}	Switching Frequency	V _{BAT} =2.8V to 5.2V	Boost	—	1200	—	kHz
			Class D	—	300	—	
G _V	Closed-Loop Gain	—	—	—	20	—	dB
R _{IN}	Input Impedance	A _V =20dB	—	—	24	—	KΩ
V _{OS}	Output Offset Voltage	Input AC-ground	—	—	—	20	mV
I _{PEAK}	Convertor SW Peak Current	V _{BAT} =3.6V	—	—	4	—	A
t _{ON}	Start-Up Time From EN	—	—	—	6	—	ms
V _{IH}	En Input High Voltage	V _{BAT} =5V	—	1.3	—	—	V
V _{IL}	En Input Low Voltage	V _{BAT} =5V	—	—	—	0.6	

Performance Characteristics (@ $V_{BAT}=3.6V$, $AGC=GND$, $T_A = +25^\circ C$, $R_L=8\Omega +33\mu H$, unless otherwise specified.)

THD+N vs. Output Power ($R_L = 8\Omega$)

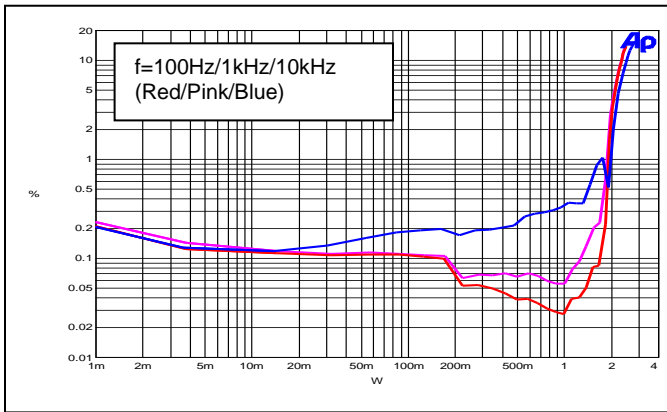

THD+N vs. Output Power ($R_L = 4\Omega$)

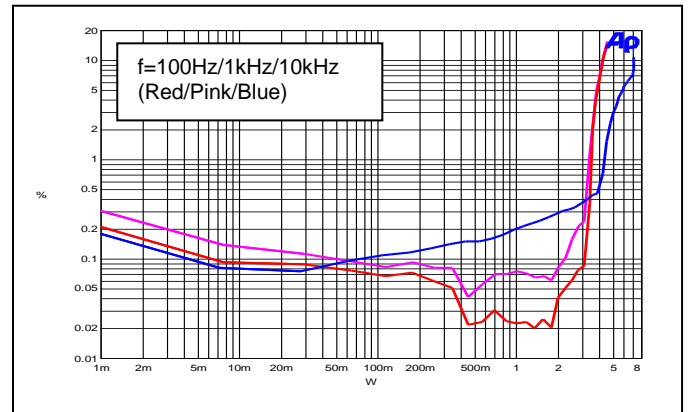

THD+N vs. Frequency ($R_L = 8\Omega$)

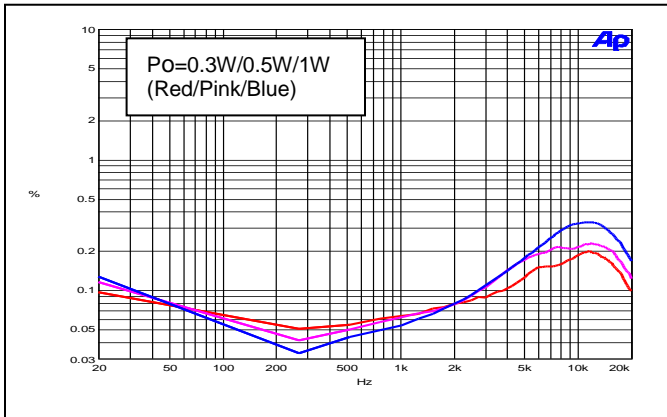

THD+N vs. Frequency ($R_L = 4\Omega$)

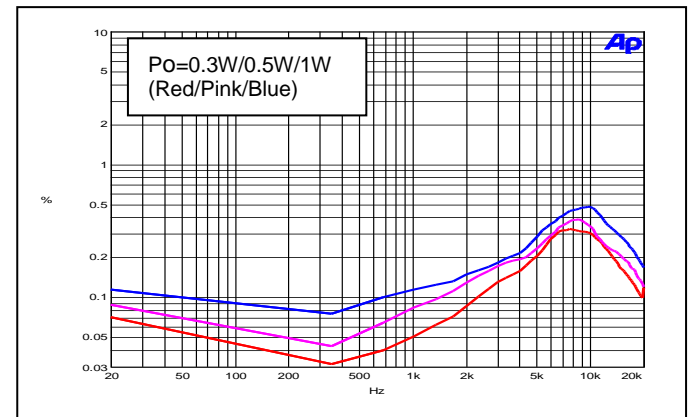

PSRR vs. Frequency ($R_L = 8\Omega$)

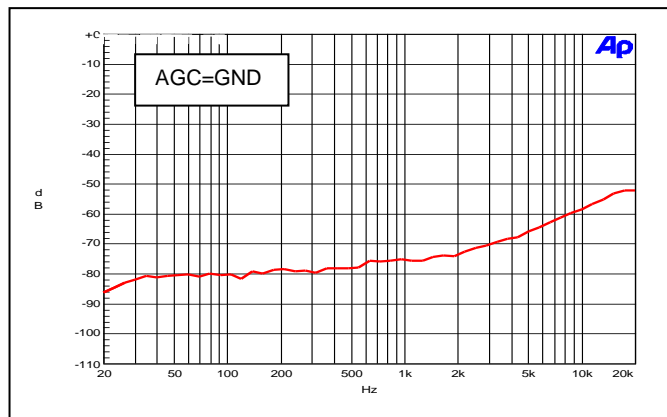

PSRR vs. Frequency ($R_L = 4\Omega$)

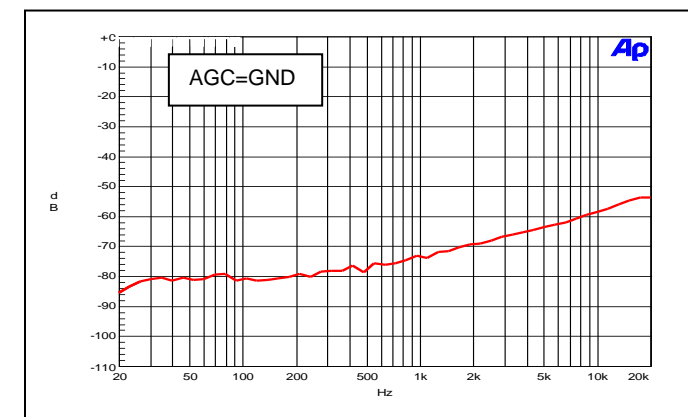

NEW PRODUCT

Performance Characteristics (@V_{BAT}=3.6V, AGC=GND, T_A = +25°C, R_L=8Ω +33μH, unless otherwise specified.)

Noise Floor (R_L =8Ω)

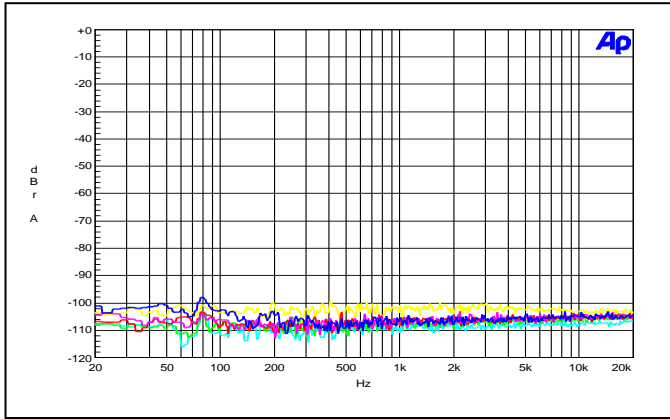

Gain vs. Supply Voltage

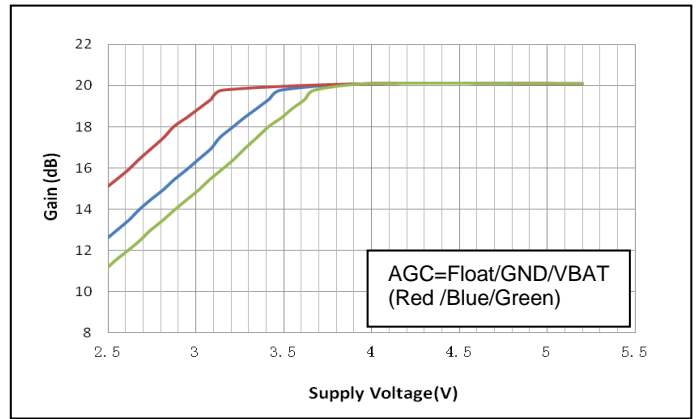

Efficiency vs. Output Power (R_L =8Ω)

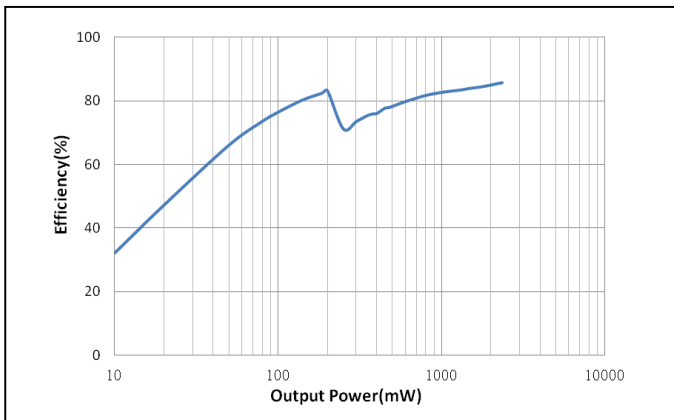

Quiescent Current vs. Supply Voltage

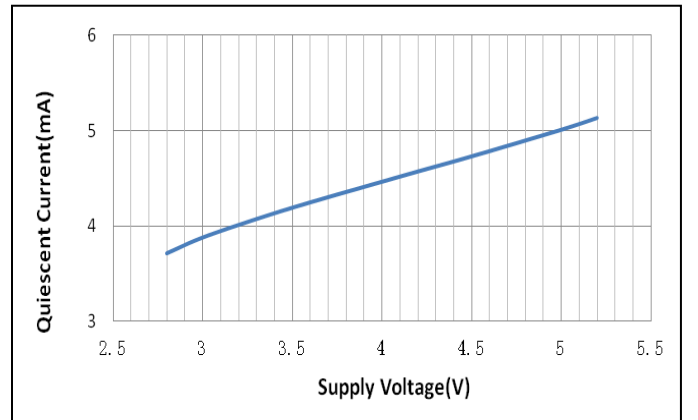

Start Up

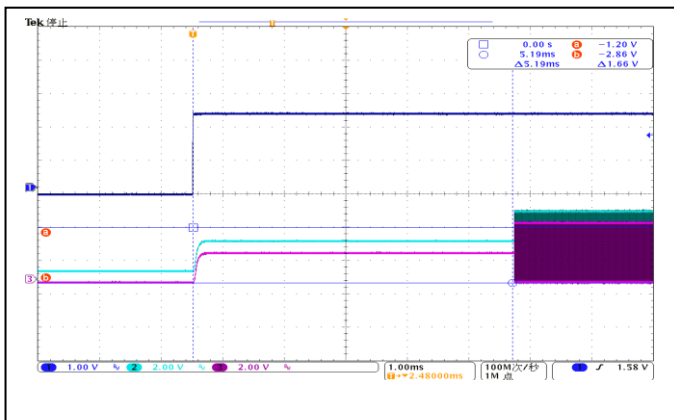

Shutdown

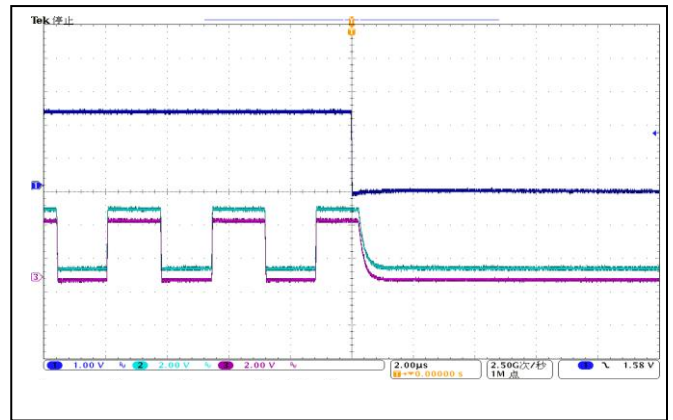

Ordering Information (Note 4)

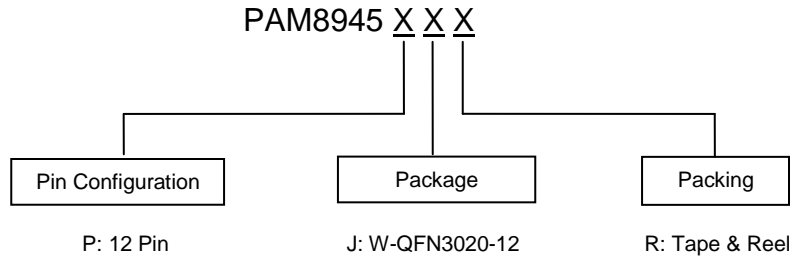

Part Number	Package	7" Tape and Reel	
		Quantity	Part Number Suffix
PAM8945PJR	W-QFN3020-12	3000/Tape & Reel	-7

Note: 4. For packaging details, go to our website at <http://www.diodes.com/products/packages.html>.

Marking Information

W-QFN3020-12

(Top View)

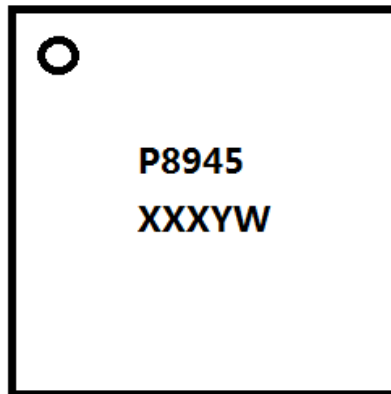

P8945: Product Code
 X: Internal Code
 Y: Year 0~9
 W: Week: A~Z: 1~26 weeks;
 a~z: 27~52 weeks; z
 represents 52 and 53 weeks.

Package Outline Dimensions

Please see AP02002 at <http://www.diodes.com/datasheets/ap02002.pdf> for the latest version.

W-QFN3020-12

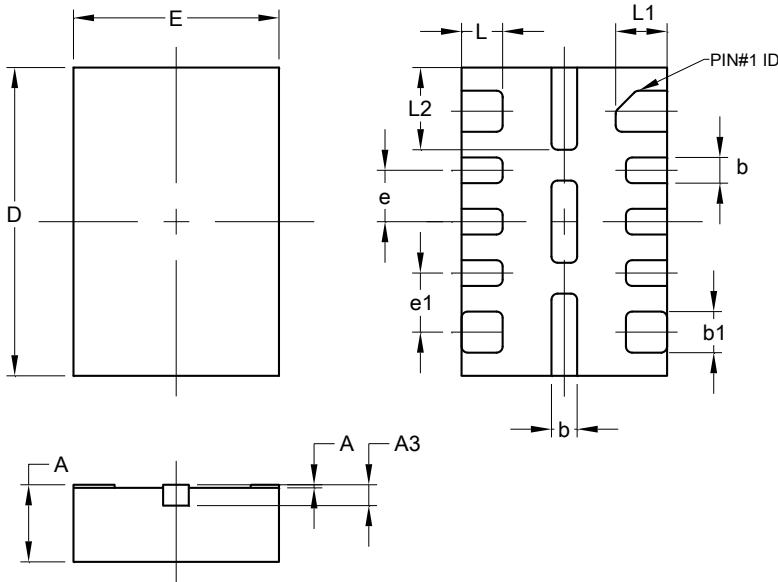

W-QFN3020-12			
Dim	Min	Max	Typ
A	0.700	0.800	-
A1	0	0.05	-
A3	0.203REF		
b	0.200	0.300	-
b1	0.350	0.450	-
D	1.900	2.100	2.000
E	2.900	3.100	3.000
e	-	-	0.500
e1	-	-	0.575
L	0.350	0.450	-
L1	0.450	0.550	-
L2	0.750	0.850	-
All Dimensions in mm			

Suggested Pad Layout

Please see AP02001 at <http://www.diodes.com/datasheets/ap02001.pdf> for the latest version.

W-QFN3020-12

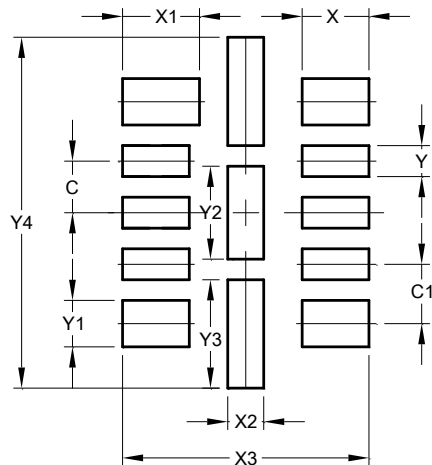

Dimensions	Value (in mm)
C	0.500
G	0.575
X	0.650
X1	0.750
X2	0.350
X3	2.400
Y	0.300
Y1	0.450
Y2	0.900
Y3	1.050
Y4	3.400

IMPORTANT NOTICE

DIODES INCORPORATED MAKES NO WARRANTY OF ANY KIND, EXPRESS OR IMPLIED, WITH REGARDS TO THIS DOCUMENT, INCLUDING, BUT NOT LIMITED TO, THE IMPLIED WARRANTIES OF MERCHANTABILITY AND FITNESS FOR A PARTICULAR PURPOSE (AND THEIR EQUIVALENTS UNDER THE LAWS OF ANY JURISDICTION).

Diodes Incorporated and its subsidiaries reserve the right to make modifications, enhancements, improvements, corrections or other changes without further notice to this document and any product described herein. Diodes Incorporated does not assume any liability arising out of the application or use of this document or any product described herein; neither does Diodes Incorporated convey any license under its patent or trademark rights, nor the rights of others. Any Customer or user of this document or products described herein in such applications shall assume all risks of such use and will agree to hold Diodes Incorporated and all the companies whose products are represented on Diodes Incorporated website, harmless against all damages.

Diodes Incorporated does not warrant or accept any liability whatsoever in respect of any products purchased through unauthorized sales channel. Should Customers purchase or use Diodes Incorporated products for any unintended or unauthorized application, Customers shall indemnify and hold Diodes Incorporated and its representatives harmless against all claims, damages, expenses, and attorney fees arising out of, directly or indirectly, any claim of personal injury or death associated with such unintended or unauthorized application.

Products described herein may be covered by one or more United States, international or foreign patents pending. Product names and markings noted herein may also be covered by one or more United States, international or foreign trademarks.

This document is written in English but may be translated into multiple languages for reference. Only the English version of this document is the final and determinative format released by Diodes Incorporated.

LIFE SUPPORT

Diodes Incorporated products are specifically not authorized for use as critical components in life support devices or systems without the express written approval of the Chief Executive Officer of Diodes Incorporated. As used herein:

A. Life support devices or systems are devices or systems which:

1. are intended to implant into the body, or
2. support or sustain life and whose failure to perform when properly used in accordance with instructions for use provided in the labeling can be reasonably expected to result in significant injury to the user.

B. A critical component is any component in a life support device or system whose failure to perform can be reasonably expected to cause the failure of the life support device or to affect its safety or effectiveness.

Customers represent that they have all necessary expertise in the safety and regulatory ramifications of their life support devices or systems, and acknowledge and agree that they are solely responsible for all legal, regulatory and safety-related requirements concerning their products and any use of Diodes Incorporated products in such safety-critical, life support devices or systems, notwithstanding any devices- or systems-related information or support that may be provided by Diodes Incorporated. Further, Customers must fully indemnify Diodes Incorporated and its representatives against any damages arising out of the use of Diodes Incorporated products in such safety-critical, life support devices or systems.

Copyright © 2015, Diodes Incorporated

www.diodes.com

Компания «Океан Электроники» предлагает заключение долгосрочных отношений при поставках импортных электронных компонентов на взаимовыгодных условиях!

Наши преимущества:

- Поставка оригинальных импортных электронных компонентов напрямую с производств Америки, Европы и Азии, а так же с крупнейших складов мира;
- Широкая линейка поставок активных и пассивных импортных электронных компонентов (более 30 млн. наименований);
- Поставка сложных, дефицитных, либо снятых с производства позиций;
- Оперативные сроки поставки под заказ (от 5 рабочих дней);
- Экспресс доставка в любую точку России;
- Помощь Конструкторского Отдела и консультации квалифицированных инженеров;
- Техническая поддержка проекта, помощь в подборе аналогов, поставка прототипов;
- Поставка электронных компонентов под контролем ВП;
- Система менеджмента качества сертифицирована по Международному стандарту ISO 9001;
- При необходимости вся продукция военного и аэрокосмического назначения проходит испытания и сертификацию в лаборатории (по согласованию с заказчиком);
- Поставка специализированных компонентов военного и аэрокосмического уровня качества (Xilinx, Altera, Analog Devices, Intersil, Interpoint, Microsemi, Actel, Aeroflex, Peregrine, VPT, Syfer, Eurofarad, Texas Instruments, MS Kennedy, Miteq, Cobham, E2V, MA-COM, Hittite, Mini-Circuits, General Dynamics и др.);

Компания «Океан Электроники» является официальным дистрибьютором и эксклюзивным представителем в России одного из крупнейших производителей разъемов военного и аэрокосмического назначения «JONHON», а так же официальным дистрибьютором и эксклюзивным представителем в России производителя высокотехнологичных и надежных решений для передачи СВЧ сигналов «FORSTAR».



JONHON

«JONHON» (основан в 1970 г.)

Разъемы специального, военного и аэрокосмического назначения:

(Применяются в военной, авиационной, аэрокосмической, морской, железнодорожной, горно- и нефтедобывающей отраслях промышленности)

«FORSTAR» (основан в 1998 г.)

ВЧ соединители, коаксиальные кабели, кабельные сборки и микроволновые компоненты:

(Применяются в телекоммуникациях гражданского и специального назначения, в средствах связи, РЛС, а так же военной, авиационной и аэрокосмической отраслях промышленности).



Телефон: 8 (812) 309-75-97 (многоканальный)

Факс: 8 (812) 320-03-32

Электронная почта: ocean@oceanchips.ru

Web: <http://oceanchips.ru/>

Адрес: 198099, г. Санкт-Петербург, ул. Калинина, д. 2, корп. 4, лит. А