

32-Bit

Microcontroller

TC233 / TC234 / TC237

32-Bit Single-Chip Microcontroller
AC-Step

32-Bit Single-Chip Microcontroller

Data Sheet

V 1.0, 2017-03

Edition 2017-03

**Published by
Infineon Technologies AG
81726 Munich, Germany**

**© 2017 Infineon Technologies AG
All Rights Reserved.**

Legal Disclaimer

The information given in this document shall in no event be regarded as a guarantee of conditions or characteristics. With respect to any examples or hints given herein, any typical values stated herein and/or any information regarding the application of the device, Infineon Technologies hereby disclaims any and all warranties and liabilities of any kind, including without limitation, warranties of non-infringement of intellectual property rights of any third party.

Information

For further information on technology, delivery terms and conditions and prices, please contact the nearest Infineon Technologies Office (www.infineon.com)

Warnings

Due to technical requirements, components may contain dangerous substances. For information on the types in question, please contact the nearest Infineon Technologies Office.

Infineon Technologies components may be used in life-support devices or systems only with the express written approval of Infineon Technologies, if a failure of such components can reasonably be expected to cause the failure of that life-support device or system or to affect the safety or effectiveness of that device or system. Life support devices or systems are intended to be implanted in the human body or to support and/or maintain and sustain and/or protect human life. If they fail, it is reasonable to assume that the health of the user or other persons may be endangered.

Revision History

Page or Item	Subjects (major changes since previous revision)
V 1.0, 2017-03	
	The history is documented in the last chapter

Trademarks of Infineon Technologies AG

AURIX™, C166™, CanPAK™, CIPOS™, CIPURSE™, EconoPACK™, CoolMOS™, CoolSET™, CORECONTROL™, CROSSAVE™, DAVE™, DI-POL™, EasyPIM™, EconoBRIDGE™, EconoDUAL™, EconoPIM™, EconoPACK™, EiceDRIVER™, eupec™, FCOS™, HITFET™, HybridPACK™, I²RF™, ISOFACE™, IsoPACK™, MIPAQ™, ModSTACK™, my-d™, NovalithIC™, OptiMOS™, ORIGA™, POWERCODE™; PRIMARION™, PrimePACK™, PrimeSTACK™, PRO-SIL™, PROFET™, RASIC™, ReverSave™, SatRIC™, SIEGET™, SINDRION™, SIPMOS™, SmartLEWIS™, SOLID FLASH™, TEMPFET™, thinQ!™, TRENCHSTOP™, TriCore™.

Other Trademarks

Advance Design System™ (ADS) of Agilent Technologies, AMBA™, ARM™, MULTI-ICE™, KEIL™, PRIMECELL™, REALVIEW™, THUMB™, μ Vision™ of ARM Limited, UK. AUTOSAR™ is licensed by AUTOSAR development partnership. Bluetooth™ of Bluetooth SIG Inc. CAT-iq™ of DECT Forum. COLOSSUS™, FirstGPS™ of Trimble Navigation Ltd. EMV™ of EMVCo, LLC (Visa Holdings Inc.). EPCOS™ of Epcos AG. FLEXGO™ of Microsoft Corporation. FlexRay™ is licensed by FlexRay Consortium. HYPERTERMINAL™ of Hilgraeve Incorporated. IEC™ of Commission Electrotechnique Internationale. IrDA™ of Infrared Data Association Corporation. ISO™ of INTERNATIONAL ORGANIZATION FOR STANDARDIZATION. MATLAB™ of MathWorks, Inc. MAXIM™ of Maxim Integrated Products, Inc. MICROTEC™, NUCLEUS™ of Mentor Graphics Corporation. MIPI™ of MIPI Alliance, Inc. MIPS™ of MIPS Technologies, Inc., USA. muRata™ of MURATA MANUFACTURING CO., MICROWAVE OFFICE™ (MWO) of Applied Wave Research Inc., OmniVision™ of OmniVision Technologies, Inc. Openwave™ Openwave Systems Inc. RED HAT™ Red Hat, Inc. RFMD™ RF Micro Devices, Inc. SIRIUS™ of Sirius Satellite Radio Inc. SOLARIS™ of Sun Microsystems, Inc. SPANSION™ of Spansion LLC Ltd. Symbian™ of Symbian Software Limited. TAIYO YUDEN™ of Taiyo Yuden Co. TEAKLITE™ of CEVA, Inc. TEKTRONIX™ of Tektronix Inc. TOKO™ of TOKO KABUSHIKI KAISHA TA. UNIX™ of X/Open Company Limited. VERILOG™, PALLADIUM™ of Cadence Design Systems, Inc. VLYNQ™ of Texas Instruments Incorporated. VXWORKS™, WIND RIVER™ of WIND RIVER SYSTEMS, INC. ZETEX™ of Diodes Zetex Limited.

Last Trademarks Update 2011-11-11

Table of Contents

1	Summary of Features	1
2	Package and Pinning Definitions	5
2.1	PG-LFBGA-292-6 Package Variant Pin Configuration of TC237x	5
2.1.1	Port Functions and Pinning Tables	6
2.1.1.1	How to Read the Following Port Function Tables	6
2.1.1.2	Tables	7
2.1.2	Pull-Up/Pull-Down Reset Behavior of the Pins	69
2.2	PG-TQFP-144-27 Package Variant Pin Configuration of TC23x-ADAS	70
2.2.1	Port Functions and Pinning Tables	71
2.2.1.1	How to Read the Following Port Function Tables	71
2.2.1.2	Tables	71
2.2.2	Pull-Up/Pull-Down Reset Behavior of the Pins	132
2.3	PG-TQFP-100-23 Package Variant Pin Configuration of TC233x	132
2.3.1	Port Functions and Pinning Tables	134
2.3.1.1	How to Read the Following Port Function Tables	134
2.3.1.2	Tables	135
2.3.2	Pull-Up/Pull-Down Reset Behavior of the Pins	172
3	Electrical Specification	173
3.1	Parameter Interpretation	173
3.2	Absolute Maximum Ratings	174
3.3	Pin Reliability in Overload	175
3.4	Operating Conditions	177
3.5	3.3 V Pads	179
3.6	VADC Parameters	183
3.7	MHz Oscillator	188
3.8	Back-up Clock	189
3.9	Temperature Sensor	190
3.10	Power Supply Current	191
3.10.1	Calculating the 1.3 V Current Consumption	193
3.11	Power-up and Power-down	195
3.11.1	Single Supply mode	196
3.11.2	External Supply mode	198
3.12	Reset Timing	199
3.13	EVR	201
3.14	Phase Locked Loop (PLL)	204
3.15	ERAY Phase Locked Loop (ERAY_PLL)	205
3.16	AC Specifications	206
3.17	JTAG Parameters	207
3.18	DAP Parameters	209
3.19	ASCLIN SPI Master Timing	211
3.20	QSPI Timings, Master and Slave Mode	213
3.21	Ethernet Interface (ETH) Characteristics	217
3.21.1	ETH Measurement Reference Points	217
3.21.2	ETH Management Signal Parameters (ETH_MDC, ETH_MDIO)	218
3.21.3	ETH MII Parameters	219
3.21.4	ETH RMII Parameters	220
3.22	E-Ray Parameters	221
3.23	Flash Parameters	223

3.24	Package Outline	226
3.24.1	Package Parameters	228
3.25	Quality Declarations	230
4	History	231
4.1	Changes from Version TC23x_DS_v1.1 to Version TC23xAC_DS_v1.0	231

1 Summary of Features

The TC23x product family has the following features:

- High Performance Microcontroller with one CPU core
- Power Efficient scalar TriCore CPU (TC1.6E), having the following features:
 - Binary code compatibility with TC1.6P
 - up to 200 MHz operation at full temperature range
 - up to 184 Kbyte Data Scratch-Pad RAM (DSPR)
 - up to 8 Kbyte Instruction Scratch-Pad RAM (PSPR)
 - 8 Kbyte Instruction Cache (ICACHE)
 - 4 line read buffer (DRB)
- Lockstepped shadow core for TC1.6E
- Multiple on-chip memories
 - All embedded NVM and SRAM are ECC protected
 - up to 2 Mbyte Program Flash Memory (PFLASH)
 - up to 128 Kbyte Data Flash Memory (DFLASH) usable for EEPROM emulation
 - 32 Kbyte Memory (LMU)
 - 512 Kbyte Memory (EMEM)
 - BootROM (BROM)
- 16-Channel DMA Controller with safe data transfer
- Sophisticated interrupt system (ECC protected)
- High performance on-chip bus structure
 - 64-bit Cross Bar Interconnect (SRI) giving fast parallel access between bus masters, CPUs and memories
 - 32-bit System Peripheral Bus (SPB) for on-chip peripheral and functional units
 - One bus bridge (SFI Bridge)
- Optional Hardware Security Module (HSM) on some variants (See below)
- Safety Management Unit (SMU) handling safety monitor alarms
- Memory Test Unit with ECC, Memory Initialization and MBIST functions (MTU)
- Hardware I/O Monitor (IOM) for checking of digital I/O
- Versatile On-chip Peripheral Units
 - Two Asynchronous/Synchronous Serial Channels (ASCLIN) with hardware LIN support (V1.3, V2.0, V2.1 and J2602) up to 50 MBaud
 - Four Queued SPI Interface Channels (QSPI) with master and slave capability up to 50 Mbit/s
 - Two MultiCAN+ Module with 3CAN nodes each and 128 free assignable message objects for high efficiency data handling via FIFO buffering and gateway data transfer
 - 4 Single Edge Nibble Transmission (SENT) channels for connection to sensors
 - One FlexRay™ module with 2 channels (E-Ray) supporting V2.1
 - One Generic Timer Module (GTM) providing a powerful set of digital signal filtering and timer functionality to realize autonomous and complex Input/Output management
 - One Capture / Compare 6 module (Two kernels CCU60 and CCU61)
 - One General Purpose 12 Timer Unit (GPT120)
 - IEEE802.3 Ethernet MAC with RMII and MII interfaces (ETH)
- Versatile Successive Approximation ADC (VADC)

- Cluster of 4 independent ADC kernels
- Input voltage range from 0 V to 5.5V (ADC supply)
- Digital programmable I/O ports
- On-chip debug support for OCDS Level 1 (CPUs, DMA, On Chip Buses)
- Four/five wire JTAG (IEEE 1149.1) or DAP (Device Access Port) interface
- Power Management System and on-chip regulators
- Clock Generation Unit with System PLL and Flexray PLL
- Embedded Voltage Regulator

Ordering Information

The ordering code for Infineon microcontrollers provides an exact reference to the required product. This ordering code identifies:

- The derivative itself, i.e. its function set, the temperature range, and the supply voltage
- The package and the type of delivery.

For the available ordering codes for the TC233 / TC234 / TC237 please refer to the “**AURIX TC23x Microcontrollers Variant Overview**”, which summarizes all available variants.

Table 1-1 Overview of TC23x Functions

Feature		
CPU Core	Type	TC1.6E
	E Cores / Checker Cores	1 / 1
	Max. Freq.	200 MHz
	FPU	yes
Program Flash	Size	2 Mbyte
Data Flash	Size	128 Kbyte
Cache	Instruction	8 Kbyte
	Data	4 line read buffer
SRAM	Size TC1.6E (DSPR/PSPR)	184 Kbyte / 8 Kbyte ¹⁾
	Size EMEM	0 Kbyte
	Size LMU	0 Kbyte
DMA	Channels	16
ADC	Channels	12+12
	Converter	2
GTM	TIM	1
	TOM	2
	DTM	2
	CMU / ICM	1 / 1
	TBU	1
Timer	GPT12	1
	CCU6	1
STM	Modules	1
FlexRay	Modules	1
	Channels	2
CAN	Modules	2
	Nodes per Module	3
	Message Objects	128
	CAN FD	yes
QSPI	Channels	4

Table 1-1 Overview of TC23x Functions (cont'd)

Feature		
ASCLIN	Interfaces	2
SENT	Channels	4
Ethernet	Channels	0
ASIL	Level	up to ASIL-D
Safety support	SMU	1
	IOM	1
FFT		0
HSIC	Channels	2
Security	HSM	1
Embedded Voltage Regulator	DCDC from 3.3 V to 1.3 V	Yes
Embedded Voltage Regulator	LDO from 3.3 V to 1.3 V	Yes
Low Power Feature	Standby RAM	Yes
Packages	Type	PG-TQFP-100-23 / PG-TQFP-144-27 / PG-LFBGA-292-6
I/O	Type	3.3 V CMOS (5V input supported on ADC pins)
T _{ambient}	Range	-40 ... +125°C / +150°C

- 1) To ensure the processor cores are provided with a constant stream of instructions the Instruction Fetch Units will speculatively fetch instructions from the up to 64 bytes ahead of the current PC. If the current PC is within 64 bytes of the top of an instruction memory the Instruction Fetch Unit may attempt to speculatively fetch instruction from beyond the physical range. This may then lead to error conditions and alarms being triggered by the bus and memory systems. It is therefore recommended that the upper 64 bytes of any memory be unused for instruction storage.

2 Package and Pinning Definitions

This chapter gives a pinning of the different packages of the TC233 / TC234 / TC237.

2.1 PG-LFBGA-292-6 Package Variant Pin Configuration of TC237x

Figure 2-1 is showing the TC237x pinout for the package variant: PG-LFBGA-292-6.

	20	19	18	17	16	15	14	13	12	11	10	9	8	7	6	5	4	3	2	1																							
Y	V _{SS}	NC	VCAP1	VCAP0	NC	P33.11	P33.9	P33.7	P33.5	P33.3	P33.1	AN1/P40.1	AN3/P40.3	V _{AGND}	V _{ARF}	V _{DDM}	V _{SM}	AN9/P40.9	AN10/P40.10	NC	Y																						
W	V _{DDP3}	V _{SS}	NC	NC	P33.12	P33.10	P33.8	P33.6	P33.4	P33.2	P33.0	AN0/P40.0	AN2/P40.2	AN4/P40.4	AN5/P40.5	AN6/P40.6	AN7/P40.7	AN8/P40.8	NC	AN11/P40.11	W																						
V	NC	V _{DDP3}																		AN12/P41.0	AN13/P41.1	V																					
U	NC	P23.1	V _{SS}	NC	NC	NC	NC	P34.3	P34.1	P34.0	NC	NC	NC	NC	NC	NC	NC	NC	NC	AN14/P41.2	AN15/P41.3	U																					
T	NC	NC	NC	V _{SS}	NC	NC	NC	P34.2	V _{DDP3}	NC	NC	NC	NC	NC	NC	NC	NC	NC	NC	NC	NC	T																					
R	P22.2	P22.3	NC	NC																		NC	NC	AN17/P41.5	AN16/P41.4	R																	
P	P22.0	P22.1	NC	P22.4																		NC	NC	AN18/P41.6	AN19/P41.7	P																	
N	V _{DDP3}	V _{DD}	NC	NC																		V _{DD}	V _{SS}	AN21/P41.9	AN20/P41.8	N																	
M	XTAL1	XTAL2	NC	NC																		V _{SS}	V _{SS}	AN23/P41.11	AN22/P41.10	M																	
L	V _{SS}	TRST	NC	NC																		V _{SS}	V _{SS}	V _{SS}	V _{SS}	V _{SS}	V _{SS}	V _{SS}	V _{SS}	NC	NC	L											
K	P21.4	P21.2	NC	TMS/DAP1																		NC	V _{SS}	V _{SS}	V _{SS}	V _{SS}	V _{SS}	V _{SS}	V _{SS}	V _{SS}	V _{SS}	NC	P00.8	P00.9	P00.7	K							
J	P21.5	P21.3	NC	TCK/DAP0																		V _{SS}	V _{SS}	V _{SS}	V _{SS}	V _{SS}	V _{SS}	V _{SS}	V _{SS}	V _{SS}	V _{SS}	NC	P00.6	P00.5	P00.4	J							
H	P20.0	P20.2	P21.6	P21.7																		V _{DD}	V _{SS}	V _{SS}	V _{SS}	V _{SS}	V _{SS}	V _{SS}	V _{SS}	V _{SS}	V _{SS}	NC	NC	P00.3	P00.2	H							
G	P20.3	NC	PORST	ESR1																		V _{DD}	V _{SS}	V _{SS}	V _{SS}	V _{SS}	V _{SS}	V _{SS}	V _{SS}	V _{SS}	V _{SS}	NC	NC	P00.1	P00.0	G							
F	P20.8	P20.7	P20.6	ESR0																																			NC	NC	P02.7	P02.8	F
E	P20.11	P20.10	P20.9	V _{SS}	V _{DDP3}	P15.5	P14.2	NC	NC	NC	NC	NC	NC	NC	P11.8	NC	V _{SS}	NC	P02.5	P02.6	E																						
D	P20.13	P20.12	V _{SS}	V _{DDP3}	P15.7	P15.8	P14.7	NC	NC	NC	P11.6	NC	NC	NC	NC	V _{DDP3}	V _{SS}	P02.3	P02.4	D																							
C	P20.14	P15.2																		P02.1	P02.2	C																					
B	P15.0	V _{SS}	V _{DDP3}	P15.3	P14.0	P14.4	P14.3	P14.6	P13.0	P13.2	P11.3	P11.10	P11.12	P10.1	NC	P10.5	NC	V _{DDP3}	V _{SS}	P02.0	B																						
A	V _{SS}	V _{DDP3}	P15.1	P15.4	P15.6	P14.5	P14.8	P13.1	P13.3	P11.2	P11.9	P11.11	NC	P10.3	P10.2	P10.6	NC	V _{DDP3}	NC	A																							

TC23x - (top view)

Figure 2-1 TC237x Pinout for the package variant PG-LFBGA-292-6.

2.1.1 Port Functions and Pinning Tables

2.1.1.1 How to Read the Following Port Function Tables

Some hints for interpreting the following tables.

Column “Ctrl.”:

I = Input (for GPIO port Lines with IOCR bit field Selection PCx = 0XXX_B)

AI = Analog input

O = Output

O0 = Output with IOCR bit field selection PCx = 1X000_B

O1 = Output with IOCR bit field selection PCx = 1X001_B (ALT1)

O2 = Output with IOCR bit field selection PCx = 1X010_B (ALT2)

O3 = Output with IOCR bit field selection PCx = 1X011_B (ALT3)

O4 = Output with IOCR bit field selection PCx = 1X100_B (ALT4)

O5 = Output with IOCR bit field selection PCx = 1X101_B (ALT5)

O6 = Output with IOCR bit field selection PCx = 1X110_B (ALT6)

O7 = Output with IOCR bit field selection PCx = 1X111_B (ALT7)

Table 2-1 Example Port Table

Ball	Symbol	Ctrl.	Buffer Type	Function
G10	Pxx.y	I	A1/HighZ/ VDDP3	General-purpose input
	TIMm_n			GTM_TIN
	TOMa_b	O1		GTM_TOUT
	TOMc_d			GTM_TOUT
	IOM_REFv_w			IOM reference input
	ASCLINz_RTS	O2		ASCLIN0 output (aka ARTSz)

To each input several functions can be connected. The peripherals' configuration defines if this input is used.

The port module (see corresponding chapter) decides which of the 8 output signals O0 to O7 drives the pad.

Some Ox rows list more than one function, e.g. several GTM_TOUT outputs and IOM reference inputs. The GTM module (see corresponding chapter) has its own sub-multiplexer structure that defines which of the GTM sub-units drives this signal. Additionally the IOM modules “listens” on these output signals (see IOM chapter).

Some pin symbol names were changed in this AURIX device compared to other AURIX devices to improve naming systematics. The previously used symbol name is documented in the “Function” column with the text “(aka ...)”¹⁾.

Column “Type”:

IN = Input only

A1 = Pad class A1 (3.3V)

A1+ = Pad class A1+ (3.3V)

S = ADC with digital input. Pad class D for analog input “AI”, pad class S for digital input “I”.

1) “aka” as abbreviation for “also known as”.

PU = with pull-up device connected during reset ($\overline{\text{PORST}} = 0$)

PD = with pull-down device connected during reset ($\overline{\text{PORST}} = 0$)

High-Z = High-Z during reset ($\overline{\text{PORST}} = 0$)

2.1.1.2 Tables

Port function and pinning tables.

Table 2-2 Port 00 Functions

Ball	Symbol	Ctrl.	Buffer Type	Function
G1	P00.0	I	A1 / HighZ / VDDP3	General-purpose input
	TIM0_0			GTM_TIN
	CCU61_CTRAPA			CCU61 input
	CCU60_T12HRE			CCU60 input
	P00.0	O0	A1 / HighZ / VDDP3	General-purpose output
	TOM0_8	O1		GTM_TOUT
	TOM1_0	O1		GTM_TOUT
	TOM0_4			GTM_TOUT (= DTM1_OUT4)
	TOM1_4			GTM_TOUT (= DTM5_OUT4)
	IOM_REF0_9			IOM reference input
	ASCLIN0_SCLK	O2		ASCLIN0 output (aka: ASCLK0)
	ASCLIN0_TX	O3		ASCLIN0 output (aka: ATX0)
	IOM_MON2_12	O3		IOM monitor input
	IOM_REF2_12			IOM reference input
	—			O4
	CAN1_TXD	O5		CAN node 1 output (aka: TXDCAN1)
	IOM_MON2_6	O5		IOM monitor input
	IOM_REF2_6			IOM reference input
	—			O6
	CCU60_COUT63	O7		CCU60 output
IOM_MON1_6	O7	IOM monitor input		
IOM_REF1_0		IOM reference input		

Table 2-2 Port 00 Functions (cont'd)

Ball	Symbol	Ctrl.	Buffer Type	Function
G2	P00.1	I	A1 / HighZ / VDDP3	General-purpose input
	TIM0_1			GTM_TIN
	ASCLIN0_RXC			ASCLIN0 input (aka: ARX0C)
	CAN1_RXDD			CAN node 1 input (aka: RXDCAN1D)
	SENT_SENT0B			SENT input
	CCU60_CC60INB			CCU60 input
	CCU61_CC60INA			CCU61 input
	P00.1			O0
	TOM0_9	O1	GTM_TOUT	
	TOM1_1		GTM_TOUT	
	TOM0_4N		GTM_TOUT (= DTM1_OUT4_N)	
	TOM1_4N		GTM_TOUT (= DTM5_OUT4_N)	
	IOM_REF0_10		IOM reference input	
	ASCLIN0_TX	O2	ASCLIN0 output (aka: ATX0)	
	IOM_MON2_12	IOM monitor input		
	IOM_REF2_12	IOM reference input		
	—	O3	Reserved	
	—	O4	Reserved	
	—	O5	Reserved	
	SENT_SPC0	O6	SENT output	
CCU61_CC60	O7	CCU61 output		
IOM_MON1_8		IOM monitor input		
IOM_REF1_13		IOM reference input		

Package and Pinning Definitions PG-LFBGA-292-6 Package Variant Pin

Table 2-2 Port 00 Functions (cont'd)

Ball	Symbol	Ctrl.	Buffer Type	Function	
H1	P00.2	I	A1 / HighZ / VDDP3	General-purpose input	
	TIM0_1			GTM_TIN	
	SENT_SENT1B			SENT input	
	P00.2	O0		General-purpose output	
	TOM0_9	O1		GTM_TOUT	
	TOM1_1			GTM_TOUT	
	TOM0_5			GTM_TOUT (= DTM1_OUT5)	
	TOM1_5			GTM_TOUT (= DTM5_OUT5)	
	IOM_REF0_11			IOM reference input	
	ASCLIN0_SCLK			O2	ASCLIN0 output (aka: ASCLK0)
	—			O3	Reserved
	—	O4		Reserved	
	CAN12_TXD	O5		CAN1 node 2 output (aka: TXDCAN12)	
	—	O6		Reserved	
	CCU61_COUT60	O7		CCU61 output	
	IOM_MON1_11			IOM monitor input	
	IOM_REF1_10			IOM reference input	
H2	P00.3	I	A1 / HighZ / VDDP3	General-purpose input	
	SENT_SENT2B			SENT input	
	CCU60_CC61INB			CCU60 input	
	CCU61_CC61INA			CCU61 input	
	CAN11_RXDA			CAN1 node 1 input (aka: RXDCAN11A)	
	CAN12_RXDA			CAN1 node 2 input (aka: RXDCAN12A)	
	P00.3	O0		General-purpose output	
	TOM0_10	O1		GTM_TOUT	
	TOM1_2			GTM_TOUT	
	TOM0_5N			GTM_TOUT (= DTM1_OUT5_N)	
	TOM1_5N			GTM_TOUT (= DTM5_OUT5_N)	
	IOM_REF0_12			IOM reference input	
	—	O2		Reserved	
	—	O3		Reserved	
	—	O4		Reserved	
	—	O5		Reserved	
	SENT_SPC2	O6		SENT output	
CCU61_CC61	O7	CCU61 output			
IOM_MON1_9		IOM monitor input			
IOM_REF1_12		IOM reference input			

Package and Pinning Definitions PG-LFBGA-292-6 Package Variant Pin

Table 2-2 Port 00 Functions (cont'd)

Ball	Symbol	Ctrl.	Buffer Type	Function	
J1	P00.4	I	A1 / HighZ / VDDP3	General-purpose input	
	SCU_REQ7			SCU input	
	SENT_SENT3B			SENT input	
	P00.4	O0		General-purpose output	
	TOM0_11	O1		GTM_TOUT	
	TOM1_3			GTM_TOUT	
	TOM0_6			GTM_TOUT (= DTM1_OUT6)	
	TOM1_6			GTM_TOUT (= DTM5_OUT6)	
	IOM_REF0_13			IOM reference input	
	—			O2	Reserved
	CAN10_TXD			O3	CAN1 node 0 output (aka: TXDCAN10)
	—	O4		Reserved	
	VADC_G1BFL0	O5		VADC output	
	SENT_SPC3	O6		SENT output	
	CCU61_COUT61	O7		CCU61 output	
	IOM_MON1_12			IOM monitor input	
	IOM_REF1_9			IOM reference input	
J2	P00.5	I	A1 / HighZ / VDDP3	General-purpose input	
	CCU60_CC62INB			CCU60 input	
	CCU61_CC62INA			CCU61 input	
	CAN10_RXDG			CAN1 node 0 input (aka: RXDCAN10G)	
	P00.5	O0		General-purpose output	
	TOM0_12	O1		GTM_TOUT	
	TOM1_4			GTM_TOUT (= DTM5_OUT4)	
	TOM0_6N			GTM_TOUT (= DTM1_OUT6_N)	
	TOM1_6N			GTM_TOUT (= DTM5_OUT6_N)	
	IOM_REF0_14			IOM reference input	
	—			O2	Reserved
	—			O3	Reserved
	—	O4		Reserved	
	VADC_G1BFL1	O5		VADC output	
	—	O6		Reserved	
	CCU61_CC62	O7		CCU61 output	
	IOM_MON1_10			IOM monitor input	
IOM_REF1_11	IOM reference input				

Package and Pinning Definitions PG-LFBGA-292-6 Package Variant Pin

Table 2-2 Port 00 Functions (cont'd)

Ball	Symbol	Ctrl.	Buffer Type	Function
J4	P00.6	I	A1 / HighZ / VDDP3	General-purpose input
	CAN11_RXDG			CAN1 node 1 input (aka: RXDCAN11G)
	P00.6	O0		General-purpose output
	TOM0_13	O1		GTM_TOUT
	TOM1_5			GTM_TOUT (= DTM5_OUT5)
	TOM0_7			GTM_TOUT (= DTM1_OUT7)
	TOM1_7			GTM_TOUT (= DTM5_OUT7)
	IOM_REF0_15			IOM reference input
	—	O2		Reserved
	VADC_G1BFL2	O3		VADC output
	—	O4		Reserved
	VADC_EMUX10	O5		VADC output
	—	O6		Reserved
	CCU61_COUT62	O7		CCU61 output
	IOM_MON1_13			IOM monitor input
	IOM_REF1_8			IOM reference input
K1	P00.7	I	A1 / HighZ / VDDP3	General-purpose input
	CCU61_CC60INC			CCU61 input
	CCU61_CCPOS0A			CCU61 input
	CCU60_T12HRB			CCU60 input
	GPT120_T2INA			GPT120 input
	P00.7	O0		General-purpose output
	TOM0_14	O1		GTM_TOUT
	TOM1_6			GTM_TOUT (= DTM5_OUT6)
	TOM0_7N			GTM_TOUT (= DTM1_OUT7_N)
	TOM1_7N			GTM_TOUT (= DTM5_OUT7_N)
	CAN11_TXD	O2		CAN1 node 1 output (aka: TXDCAN11)
	VADC_G1BFL3	O3		VADC output
	—	O4		Reserved
	VADC_EMUX11	O5		VADC output
	—	O6		Reserved
	CCU61_CC60	O7		CCU61 output
IOM_MON1_8	IOM monitor input			
IOM_REF1_13	IOM reference input			

Package and Pinning Definitions PG-LFBGA-292-6 Package Variant Pin

Table 2-2 Port 00 Functions (cont'd)

Ball	Symbol	Ctrl.	Buffer Type	Function
K4	P00.8	I	A1 / HighZ / VDDP3	General-purpose input
	CCU61_CC61INC			CCU61 input
	CCU61_CCPOS1A			CCU61 input
	CCU60_T13HRB			CCU60 input
	GPT120_T2EUDA			GPT120 input
	CAN12_RXDG			CAN1 node 2 input (aka: RXDCAN12G)
	P00.8	O0	A1 / HighZ / VDDP3	General-purpose output
	TOM0_15	O1		GTM_TOUT
	TOM1_7	O2		GTM_TOUT (= DTM5_OUT7)
	QSPI3_SLSO6			QSPI3 output (aka: SLSO36)
	—	O3		Reserved
	—	O4		Reserved
	VADC_EMUX12	O5		VADC output
	—	O6		Reserved
	CCU61_CC61	O7		CCU61 output
	IOM_MON1_9			IOM monitor input
IOM_REF1_12	IOM reference input			
K2	P00.9	I	A1 / HighZ / VDDP3	General-purpose input
	TIM0_0			GTM_TIN
	CCU61_CC62INC			CCU61 input
	CCU61_CCPOS2A			CCU61 input
	CCU60_T13HRC			CCU60 input
	CCU60_T12HRC			CCU60 input
	GPT120_T4EUDA	GPT120 input		
	P00.9	O0	A1 / HighZ / VDDP3	General-purpose output
	TOM0_0	O1		GTM_TOUT
	TOM1_0	O2		GTM_TOUT
	QSPI3_SLSO7			QSPI3 output (aka: SLSO37)
	ASCLIN0_RTS	O3		ASCLIN0 output (aka: ARTS0)
	—	O4		Reserved
	CAN12_TXD	O5		CAN1 node 2 output (aka: TXDCAN12)
	—	O6		Reserved
	CCU61_CC62	O7		CCU61 output
IOM_MON1_10	IOM monitor input			
IOM_REF1_11	IOM reference input			

Table 2-2 Port 00 Functions (cont'd)

Ball	Symbol	Ctrl.	Buffer Type	Function
L2	P00.12	I	A1 / HighZ / VDDP3	General-purpose input
	TIM0_3			GTM_TIN
	ASCLIN0_CTSA			ASCLIN0 input (aka: ACTS0A)
	P00.12	O0		General-purpose output
	TOM0_3	O1		GTM_TOUT
	TOM1_3			GTM_TOUT
	—	O2		Reserved
	—	O3		Reserved
	—	O4		Reserved
	—	O5		Reserved
	—	O6		Reserved
	CCU61_COUT63	O7		CCU61 output
	IOM_MON1_7			IOM monitor input
	IOM_REF1_7			IOM reference input

Table 2-3 Port 02 Functions

Ball	Symbol	Ctrl.	Buffer Type	Function
B1	P02.0	I	A1+ / HighZ / VDDP3	General-purpose input
	TIM0_0			GTM_TIN
	SCU_REQ6			SCU input
	CCU60_CC60INA			CCU60 input
	CCU61_CC60INB			CCU61 input
	P02.0	O0		General-purpose output
	TOM0_8	O1		GTM_TOUT
	TOM1_8			GTM_TOUT
	TOM0_4			GTM_TOUT (= DTM1_OUT4)
	TOM1_4			GTM_TOUT (= DTM5_OUT4)
	IOM_REF0_0		IOM reference input	
	—	O2	Reserved	
	QSPI3_SLSO1	O3	QSPI3 output (aka: SLSO31)	
	—	O4	Reserved	
	CAN0_TXD	O5	CAN node 0 output (aka: TXDCAN0)	
	IOM_MON2_5		IOM monitor input	
	IOM_REF2_5		IOM reference input	
	ERAY0_TXDA	O6	ERAY0 output	
	CCU60_CC60	O7	CCU60 output	
	IOM_MON1_2		IOM monitor input	
IOM_REF1_6	IOM reference input			

Package and Pinning Definitions PG-LFBGA-292-6 Package Variant Pin

Table 2-3 Port 02 Functions (cont'd)

Ball	Symbol	Ctrl.	Buffer Type	Function
C2	P02.1	I	A1 / HighZ / VDDP3	General-purpose input
	TIM0_1			GTM_TIN
	CAN0_RXDA			CAN node 0 input (aka: RXDCAN0A)
	ERAY0_RXDA2			ERAY0 input
	SCU_REQ14			SCU input
	P02.1	O0		General-purpose output
	TOM0_9	O1		GTM_TOUT
	TOM1_9			GTM_TOUT
	TOM0_4N			GTM_TOUT (= DTM1_OUT4_N)
	TOM1_4N			GTM_TOUT (= DTM5_OUT4_N)
	IOM_REF0_1			IOM reference input
	—	O2		Reserved
	QSPI3_SLSO2	O3		QSPI3 output (aka: SLSO32)
	—	O4		Reserved
	—	O5		Reserved
	—	O6		Reserved
	CCU60_COUT60	O7		CCU60 output
	IOM_MON1_3			IOM monitor input
	IOM_REF1_3			IOM reference input

Table 2-3 Port 02 Functions (cont'd)

Ball	Symbol	Ctrl.	Buffer Type	Function
C1	P02.2	I	A1+ / HighZ / VDDP3	General-purpose input
	TIM0_2			GTM_TIN
	CCU60_CC61INA			CCU60 input
	CCU61_CC61INB			CCU61 input
	P02.2	O0		General-purpose output
	TOM0_10	O1		GTM_TOUT
	TOM1_10		GTM_TOUT	
	TOM0_5		GTM_TOUT (= DTM1_OUT5)	
	TOM1_5		GTM_TOUT (= DTM5_OUT5)	
	IOM_REF0_2		IOM reference input	
	ASCLIN1_TX	O2		ASCLIN1 output (aka: ATX1)
	IOM_MON2_13	O3		IOM monitor input
	IOM_REF2_13		IOM reference input	
	QSPI3_SLSO3		QSPI3 output (aka: SLSO33)	
	—	O4		Reserved
	CAN2_TXD	O5		CAN node 2 output (aka: TXDCAN2)
	IOM_MON2_7		IOM monitor input	
	IOM_REF2_7		IOM reference input	
	ERAY0_TXDB	O6		ERAY0 output
	CCU60_CC61	O7		CCU60 output
IOM_MON1_1	IOM monitor input			
IOM_REF1_5	IOM reference input			

Table 2-3 Port 02 Functions (cont'd)

Ball	Symbol	Ctrl.	Buffer Type	Function
D2	P02.3	I	A1 / HighZ / VDDP3	General-purpose input
	TIM0_3			GTM_TIN
	ASCLIN1_RXG			ASCLIN1 input (aka: ARX1G)
	CAN2_RXDB			CAN node 2 input (aka: RXDCAN2B)
	ERAY0_RXDB2			ERAY0 input
	P02.3	O0		General-purpose output
	TOM0_11	O1		GTM_TOUT
	TOM1_11			GTM_TOUT
	TOM0_5N			GTM_TOUT (= DTM1_OUT5_N)
	TOM1_5N			GTM_TOUT (= DTM5_OUT5_N)
	IOM_REF0_3			IOM reference input
	—	O2		Reserved
	QSPI3_SLSO4	O3		QSPI3 output (aka: SLSO34)
	—	O4		Reserved
	—	O5		Reserved
	—	O6		Reserved
	CCU60_COUT61	O7		CCU60 output
	IOM_MON1_4			IOM monitor input
	IOM_REF1_2			IOM reference input

Table 2-3 Port 02 Functions (cont'd)

Ball	Symbol	Ctrl.	Buffer Type	Function
D1	P02.4	I	A1+ / HighZ / VDDP3	General-purpose input
	TIM0_4			GTM_TIN
	QSPI3_SLSIA			QSPI3 input (aka: SLSI3A)
	CAN0_RXDD			CAN node 0 input (aka: RXDCAN0D)
	CCU60_CC62INA			CCU60 input
	CCU61_CC62INB			CCU61 input
	P02.4	O0		General-purpose output
	TOM0_12	O1		GTM_TOUT
	TOM1_12			GTM_TOUT
	TOM0_6			GTM_TOUT (= DTM1_OUT6)
	TOM1_6			GTM_TOUT (= DTM5_OUT6)
	IOM_REF0_4			IOM reference input
	—	O2		Reserved
	QSPI3_SLSO0	O3		QSPI3 output (aka: SLSO30)
	—	O4		Reserved
	CAN10_TXD	O5		CAN1 node 0 output (aka: TXDCAN10)
	ERAY0_TXENA	O6		ERAY0 output
	CCU60_CC62	O7		CCU60 output
	IOM_MON1_0			IOM monitor input
	IOM_REF1_4			IOM reference input

Table 2-3 Port 02 Functions (cont'd)

Ball	Symbol	Ctrl.	Buffer Type	Function
E2	P02.5	I	A1+ / HighZ / VDDP3	General-purpose input
	TIM0_5			GTM_TIN
	QSPI3_MRSTA			QSPI3 input (aka: MRST3A)
	SENT_SENT3C			SENT input
	P02.5	O0		General-purpose output
	TOM0_13	O1		GTM_TOUT
	TOM1_13			GTM_TOUT
	TOM0_6N			GTM_TOUT (= DTM1_OUT6_N)
	TOM1_6N			GTM_TOUT (= DTM5_OUT6_N)
	IOM_REF0_5			IOM reference input
	CAN0_TXD	O2		CAN node 0 output (aka: TXDCAN0)
	IOM_MON2_5	O3	IOM monitor input	
	IOM_REF2_5		IOM reference input	
	QSPI3_MRST		QSPI3 output (aka: MRST3)	
	IOM_MON2_3	O4	IOM monitor input	
	IOM_REF2_3		IOM reference input	
	—	O5	Reserved	
	CAN11_TXD	O6	CAN1 node 1 output (aka: TXDCAN11)	
	ERAY0_TXENB	O7	ERAY0 output	
	CCU60_COUT62	O7	CCU60 output	
	IOM_MON1_5		IOM monitor input	
	IOM_REF1_1		IOM reference input	

Table 2-3 Port 02 Functions (cont'd)

Ball	Symbol	Ctrl.	Buffer Type	Function
E1	P02.6	I	A1 / HighZ / VDDP3	General-purpose input
	TIM0_6			GTM_TIN
	QSPI3_MTSRA			QSPI3 input (aka: MTSR3A)
	SENT_SENT2C			SENT input
	CCU60_CC60INC			CCU60 input
	CCU60_CCPOS0A			CCU60 input
	CCU61_T12HRB			CCU61 input
	GPT120_T3INA			GPT120 input
	CAN10_RXDF			CAN1 node 0 input (aka: RXDCAN10F)
	P02.6			O0
	TOM0_14	O1	GTM_TOUT	
	TOM1_14		GTM_TOUT	
	TOM0_7		GTM_TOUT (= DTM1_OUT7)	
	TOM1_7		GTM_TOUT (= DTM5_OUT7)	
	IOM_REF0_6		IOM reference input	
	—		O2	Reserved
	QSPI3_MTSR	O3	QSPI3 output (aka: MTSR3)	
	—	O4	Reserved	
	VADC_EMUX00	O5	VADC output	
	—	O6	Reserved	
	CCU60_CC60	O7	CCU60 output	
	IOM_MON1_2		IOM monitor input	
	IOM_REF1_6		IOM reference input	

Table 2-3 Port 02 Functions (cont'd)

Ball	Symbol	Ctrl.	Buffer Type	Function
F2	P02.7	I	A1 / HighZ / VDDP3	General-purpose input
	TIM0_7			GTM_TIN
	QSPI3_SCLKA			QSPI3 input (aka: SCLK3A)
	SENT_SENT1C			SENT input
	CCU60_CC61INC			CCU60 input
	CCU60_CCPOS1A			CCU60 input
	CCU61_T13HRB			CCU61 input
	GPT120_T3EUDA			GPT120 input
	CAN11_RXDF			CAN1 node 1 input (aka: RXDCAN11F)
	PMU_FDEST			PMU input
	P02.7			O0
	TOM0_15	O1	GTM_TOUT	
	TOM1_15		GTM_TOUT	
	TOM0_7N		GTM_TOUT (= DTM1_OUT7_N)	
	TOM1_7N		GTM_TOUT (= DTM5_OUT7_N)	
	IOM_REF0_7		IOM reference input	
	—	O2	Reserved	
	QSPI3_SCLK	O3	QSPI3 output (aka: SCLK3)	
	—	O4	Reserved	
	VADC_EMUX01	O5	VADC output	
	SENT_SPC1	O6	SENT output	
	CCU60_CC61	O7	CCU60 output	
	IOM_MON1_1		IOM monitor input	
IOM_REF1_5	IOM reference input			

Table 2-3 Port 02 Functions (cont'd)

Ball	Symbol	Ctrl.	Buffer Type	Function
F1	P02.8	I	A1 / HighZ / VDDP3	General-purpose input
	TIM0_0			GTM_TIN
	SENT_SENT0C			SENT input
	CCU60_CC62INC			CCU60 input
	CCU60_CCPOS2A			CCU60 input
	CCU61_T12HRC			CCU61 input
	CCU61_T13HRC			CCU61 input
	GPT120_T4INA			GPT120 input
	P02.8	O0	General-purpose output	
	TOM0_8	O1	GTM_TOUT	
	TOM1_0		GTM_TOUT	
	TOM0_4N		GTM_TOUT (= DTM1_OUT4_N)	
	TOM1_4N		GTM_TOUT (= DTM5_OUT4_N)	
	IOM_REF0_8		IOM reference input	
	QSPI3_SLSO5		O2	QSPI3 output (aka: SLSO35)
	—	O3	Reserved	
	—	O4	Reserved	
	VADC_EMUX02	O5	VADC output	
	—	O6	Reserved	
	CCU60_CC62	O7	CCU60 output	
IOM_MON1_0	IOM monitor input			
IOM_REF1_4	IOM reference input			

Table 2-4 Port 10 Functions

Ball	Symbol	Ctrl.	Buffer Type	Function
B7	P10.1	I	A1 / HighZ / VDDP3	General-purpose input
	TIM0_1			GTM_TIN
	QSPI1_MRSTA			QSPI1 input (aka: MRST1A)
	GPT120_T5EUDB			GPT120 input
	P10.1	O0		General-purpose output
	TOM0_1	O1		GTM_TOUT
	TOM1_9			GTM_TOUT
	QSPI1_MTSR	O2		QSPI1 output (aka: MTSR1)
	QSPI1_MRST	O3		QSPI1 output (aka: MRST1)
	IOM_MON2_1			IOM monitor input
	IOM_REF2_1			IOM reference input
	—	O4		Reserved
	—	O5		Reserved
	—	O6		Reserved
—	O7	Reserved		
A5	P10.2	I	A1 / HighZ / VDDP3	General-purpose input
	TIM0_2			GTM_TIN
	QSPI1_SCLKA			QSPI1 input (aka: SCLK1A)
	CAN2_RXDE			CAN node 2 input (aka: RXDCAN2E)
	SCU_REQ2			SCU input
	GPT120_T6INB			GPT120 input
	P10.2	O0		General-purpose output
	TOM0_2	O1		GTM_TOUT
	TOM1_10			GTM_TOUT
	IOM_MON2_9			IOM monitor input
	—			O2
	QSPI1_SCLK	O3		QSPI1 output (aka: SCLK1)
	—	O4		Reserved
	—	O5		Reserved
—	O6	Reserved		
—	O7	Reserved		

Table 2-4 Port 10 Functions (cont'd)

Ball	Symbol	Ctrl.	Buffer Type	Function
A6	P10.3	I	A1 / HighZ / VDDP3	General-purpose input
	TIM0_3			GTM_TIN
	QSPI1_MTSRA			QSPI1 input (aka: MTSR1A)
	SCU_REQ3			SCU input
	GPT120_T5INB			GPT120 input
	P10.3	O0		General-purpose output
	TOM0_3	O1		GTM_TOUT
	TOM1_11			GTM_TOUT
	IOM_MON2_10	O2		IOM monitor input
	—			Reserved
	QSPI1_MTSR			QSPI1 output (aka: MTSR1)
	—	O4		Reserved
	—	O5		Reserved
	CAN2_TXD	O6		CAN node 2 output (aka: TXDCAN2)
	IOM_MON2_7			IOM monitor input
IOM_REF2_7	IOM reference input			
—	O7		Reserved	
B5	P10.5	I	A1 / HighZ / VDDP3	General-purpose input
	TIM0_2			GTM_TIN
	SCU_HWCFG4			SCU input
	CAN10_RXDA			CAN1 node 0 input (aka: RXDCAN10A)
	P10.5	O0		General-purpose output
	TOM0_2	O1		GTM_TOUT
	TOM1_10			GTM_TOUT
	IOM_REF2_9	O2		IOM reference input
	—			Reserved
	QSPI3_SLSO8			QSPI3 output (aka: SLSO38)
	QSPI1_SLSO9	O4		QSPI1 output (aka: SLSO19)
	GPT120_T6OUT	O5		GPT120 output
	—	O6		Reserved
	—	O7		Reserved

Package and Pinning Definitions PG-LFBGA-292-6 Package Variant Pin

Table 2-4 Port 10 Functions (cont'd)

Ball	Symbol	Ctrl.	Buffer Type	Function
A4	P10.6	I	A1 / HighZ / VDDP3	General-purpose input
	TIM0_3			GTM_TIN
	QSPI3_MTSRB			QSPI3 input (aka: MTSR3B)
	SCU_HWCFG5			SCU input
	P10.6	O0		General-purpose output
	TOM0_3	O1		GTM_TOUT
	TOM1_11			GTM_TOUT
	IOM_REF2_10	O2		IOM reference input
	—			Reserved
	QSPI3_MTSR	O3		QSPI3 output (aka: MTSR3)
	GPT120_T3OUT	O4		GPT120 output
	CAN10_TXD	O5		CAN1 node 0 output (aka: TXDCAN10)
	QSPI1_MRST	O6		QSPI1 output (aka: MRST1)
	IOM_MON2_1			IOM monitor input
	IOM_REF2_1			IOM reference input
	—	O7		Reserved

Table 2-5 Port 11 Functions

Ball	Symbol	Ctrl.	Buffer Type	Function
A10	P11.2	I	A1+ / HighZ / VDDP3	General-purpose input
	P11.2	O0		General-purpose output
	TOM0_8	O1		GTM_TOUT
	TOM1_1			GTM_TOUT
	TOM0_4N			GTM_TOUT (= DTM1_OUT4_N)
	TOM1_4N			GTM_TOUT (= DTM5_OUT4_N)
	—	O2		Reserved
	QSPI0_SLSO5	O3		QSPI0 output (aka: SLSO05)
	QSPI1_SLSO5	O4		QSPI1 output (aka: SLSO15)
	CCU61_COUT63	O5		CCU61 output
	IOM_MON1_7			IOM monitor input
	IOM_REF1_7			IOM reference input
	—	O6		Reserved
	CCU60_COUT63	O7		CCU60 output
	IOM_MON1_6			IOM monitor input
	IOM_REF1_0			IOM reference input

Package and Pinning Definitions PG-LFBGA-292-6 Package Variant Pin

Table 2-5 Port 11 Functions (cont'd)

Ball	Symbol	Ctrl.	Buffer Type	Function
B10	P11.3	I	A1+ / HighZ / VDDP3	General-purpose input
	QSPI1_MRSTB			QSPI1 input (aka: MRST1B)
	P11.3	O0		General-purpose output
	TOM0_10	O1		GTM_TOUT
	TOM1_2			GTM_TOUT
	TOM0_5			GTM_TOUT (= DTM1_OUT5)
	TOM1_5			GTM_TOUT (= DTM5_OUT5)
	—	O2		Reserved
	QSPI1_MRST	O3		QSPI1 output (aka: MRST1)
	IOM_MON2_1			IOM monitor input
	IOM_REF2_1			IOM reference input
	ERAY0_TXDA	O4		ERAY0 output
	CCU61_COUT62	O5		CCU61 output
	IOM_MON1_13			IOM monitor input
	IOM_REF1_8			IOM reference input
	—			O6
	CCU60_COUT62	O7		CCU60 output
	IOM_MON1_5			IOM monitor input
IOM_REF1_1	IOM reference input			
D9	P11.6	I	A1+ / HighZ / VDDP3	General-purpose input
	QSPI1_SCLKB			QSPI1 input (aka: SCLK1B)
	P11.6	O0		General-purpose output
	TOM0_11	O1		GTM_TOUT
	TOM1_3			GTM_TOUT
	TOM0_5N			GTM_TOUT (= DTM1_OUT5_N)
	TOM1_5N			GTM_TOUT (= DTM5_OUT5_N)
	ERAY0_TXENB	O2		ERAY0 output
	QSPI1_SCLK	O3		QSPI1 output (aka: SCLK1)
	ERAY0_TXENA	O4		ERAY0 output
	CCU61_COUT61	O5		CCU61 output
	IOM_MON1_12			IOM monitor input
	IOM_REF1_9			IOM reference input
	—			O6
	CCU60_COUT61	O7		CCU60 output
	IOM_MON1_4			IOM monitor input
	IOM_REF1_2			IOM reference input

Table 2-5 Port 11 Functions (cont'd)

Ball	Symbol	Ctrl.	Buffer Type	Function
E7	P11.8	I	A1 / HighZ / VDDP3	General-purpose input
	QSPI1_MTSRC			QSPI1 input (aka: MTSR1C)
	P11.8	O0		General-purpose output
	TOM0_4	O1		GTM_TOUT (= DTM1_OUT4)
	TOM1_4			GTM_TOUT (= DTM5_OUT4)
	—	O2		Reserved
	QSPI1_SLSO10	O3		QSPI1 output (aka: SLSO110)
	QSPI1_MTSR	O4		QSPI1 output (aka: MTSR1)
	—	O5		Reserved
	—	O6		Reserved
	—	O7		Reserved
A9	P11.9	I	A1+ / HighZ / VDDP3	General-purpose input
	QSPI1_MTSRB			QSPI1 input (aka: MTSR1B)
	ERAY0_RXDA1			ERAY0 input
	P11.9	O0		General-purpose output
	TOM0_12	O1		GTM_TOUT
	TOM1_4			GTM_TOUT (= DTM5_OUT4)
	TOM0_6			GTM_TOUT (= DTM1_OUT6)
	TOM1_6			GTM_TOUT (= DTM5_OUT6)
	—	O2		Reserved
	QSPI1_MTSR	O3		QSPI1 output (aka: MTSR1)
	—	O4		Reserved
	CCU61_COUT60	O5		CCU61 output
	IOM_MON1_11			IOM monitor input
	IOM_REF1_10			IOM reference input
	—	O6		Reserved
	CCU60_COUT60	O7		CCU60 output
	IOM_MON1_3			IOM monitor input
IOM_REF1_3		IOM reference input		

Package and Pinning Definitions PG-LFBGA-292-6 Package Variant Pin

Table 2-5 Port 11 Functions (cont'd)

Ball	Symbol	Ctrl.	Buffer Type	Function
B9	P11.10	I	A1+ / HighZ / VDDP3	General-purpose input
	ASCLIN1_RXE			ASCLIN1 input (aka: ARX1E)
	ERAY0_RXDB1			ERAY0 input
	SCU_REQ12			SCU input
	CAN12_RXDD			CAN1 node 2 input (aka: RXDCAN12D)
	P11.10	O0		General-purpose output
	TOM0_13	O1		GTM_TOUT
	TOM1_5			GTM_TOUT (= DTM5_OUT5)
	TOM0_6N			GTM_TOUT (= DTM1_OUT6_N)
	TOM1_6N			GTM_TOUT (= DTM5_OUT6_N)
	—	O2		Reserved
	QSPIO_SLSO3	O3		QSPIO output (aka: SLSO03)
	QSPI1_SLSO3	O4		QSPI1 output (aka: SLSO13)
	CCU61_CC62	O5		CCU61 output
	IOM_MON1_10			IOM monitor input
	IOM_REF1_11			IOM reference input
	—	O6		Reserved
	CCU60_CC62	O7		CCU60 output
	IOM_MON1_0			IOM monitor input
IOM_REF1_4		IOM reference input		
A8	P11.11	I	A1+ / HighZ / VDDP3	General-purpose input
	P11.11	O0		General-purpose output
	TOM0_14	O1		GTM_TOUT
	TOM1_6			GTM_TOUT (= DTM5_OUT6)
	TOM0_7N			GTM_TOUT (= DTM1_OUT7_N)
	TOM1_7N			GTM_TOUT (= DTM5_OUT7_N)
	—	O2		Reserved
	QSPIO_SLSO4	O3		QSPIO output (aka: SLSO04)
	QSPI1_SLSO4	O4		QSPI1 output (aka: SLSO14)
	CCU61_CC61	O5		CCU61 output
	IOM_MON1_9			IOM monitor input
	IOM_REF1_12			IOM reference input
	ERAY0_TXENB	O6		ERAY0 output
	CCU60_CC61	O7		CCU60 output
	IOM_MON1_1			IOM monitor input
IOM_REF1_5		IOM reference input		

Package and Pinning Definitions PG-LFBGA-292-6 Package Variant Pin

Table 2-5 Port 11 Functions (cont'd)

Ball	Symbol	Ctrl.	Buffer Type	Function
B8	P11.12	I	A1+ / HighZ / VDDP3	General-purpose input
	P11.12	O0		General-purpose output
	TOM0_15	O1		GTM_TOUT
	TOM1_7			GTM_TOUT (= DTM5_OUT7)
	TOM0_7			GTM_TOUT (= DTM1_OUT7)
	TOM1_7			GTM_TOUT (= DTM5_OUT7)
	ASCLIN1_TX	O2		ASCLIN1 output (aka: ATX1)
	IOM_MON2_13			IOM monitor input
	IOM_REF2_13			IOM reference input
	GTM_CLK2	O3		GTM output
	ERAY0_TXDB	O4		ERAY0 output
	CCU61_CC60	O5		CCU61 output
	IOM_MON1_8			IOM monitor input
	IOM_REF1_13			IOM reference input
	SCU_EXTCLK1			O6
	CCU60_CC60	O7		CCU60 output
	IOM_MON1_2			IOM monitor input
	IOM_REF1_6			IOM reference input

Table 2-6 Port 13 Functions

Ball	Symbol	Ctrl.	Buffer Type	Function
B12	P13.0	I	A1 / HighZ / VDDP3	General-purpose input
	CCU60_CTRAPA			CCU60 input
	GPT120_T6EUDB			GPT120 input
	P13.0	O0		General-purpose output
	TOM0_5	O1		GTM_TOUT (= DTM1_OUT5)
	TOM1_5			GTM_TOUT (= DTM5_OUT5)
	TOM0_6N			GTM_TOUT (= DTM1_OUT6_N)
	TOM1_6N			GTM_TOUT (= DTM5_OUT6_N)
	—	O2		Reserved
	QSPI2_SCLK	O3		QSPI2 output (aka: SCLK2)
	—	O4		Reserved
	—	O5		Reserved
	—	O6		Reserved
	CAN10_TXD	O7		CAN1 node 0 output (aka: TXDCAN10)

Package and Pinning Definitions PG-LFBGA-292-6 Package Variant Pin

Table 2-6 Port 13 Functions (cont'd)

Ball	Symbol	Ctrl.	Buffer Type	Function
A12	P13.1	I	A1 / HighZ / VDDP3	General-purpose input
	CCU60_CCPOS0C			CCU60 input
	GPT120_T3INB			GPT120 input
	CAN10_RXDB			CAN1 node 0 input (aka: RXDCAN10B)
	P13.1	O0		General-purpose output
	TOM0_6	O1		GTM_TOUT (= DTM1_OUT6)
	TOM1_6			GTM_TOUT (= DTM5_OUT6)
	TOM0_7			GTM_TOUT (= DTM1_OUT7)
	TOM1_7			GTM_TOUT (= DTM5_OUT7)
	—	O2		Reserved
	—	O3		Reserved
	—	O4		Reserved
	—	O5		Reserved
	—	O6		Reserved
—	O7	Reserved		
B11	P13.2	I	A1 / HighZ / VDDP3	General-purpose input
	CCU60_CCPOS1C			CCU60 input
	GPT120_T3EUDB			GPT120 input
	GPT120_CAPINA			GPT120 input
	P13.2	O0		General-purpose output
	TOM0_7	O1		GTM_TOUT (= DTM1_OUT7)
	TOM1_7			GTM_TOUT (= DTM5_OUT7)
	TOM0_7N			GTM_TOUT (= DTM1_OUT7_N)
	TOM1_7N			GTM_TOUT (= DTM5_OUT7_N)
	CAN11_TXD	O2		CAN1 node 1 output (aka: TXDCAN11)
	—	O3		Reserved
	—	O4		Reserved
	—	O5		Reserved
	—	O6		Reserved
—	O7	Reserved		

Package and Pinning Definitions PG-LFBGA-292-6 Package Variant Pin

Table 2-6 Port 13 Functions (cont'd)

Ball	Symbol	Ctrl.	Buffer Type	Function
A11	P13.3	I	A1 / HighZ / VDDP3	General-purpose input
	CCU60_CCPOS2C			CCU60 input
	GPT120_T4INB			GPT120 input
	CAN11_RXDB			CAN1 node 1 input (aka: RXDCAN11B)
	P13.3	O0		General-purpose output
	TOM0_8	O1		GTM_TOUT
	TOM1_0			GTM_TOUT
	TOM0_4			GTM_TOUT (= DTM1_OUT4)
	TOM1_4			GTM_TOUT (= DTM5_OUT4)
	—	O2		Reserved
	QSPI2_MTSR	O3		QSPI2 output (aka: MTSR2)
	—	O4		Reserved
	—	O5		Reserved
	—	O6		Reserved
	—	O7		Reserved

Table 2-7 Port 14 Functions

Ball	Symbol	Ctrl.	Buffer Type	Function
B16	P14.0	I	A1+ / HighZ / VDDP3	General-purpose input
	TIM0_3			GTM_TIN
	P14.0	O0		General-purpose output
	TOM0_3	O1		GTM_TOUT
	TOM1_3			GTM_TOUT
	TOM0_6			GTM_TOUT (= DTM1_OUT6)
	TOM1_6			GTM_TOUT (= DTM5_OUT6)
	ASCLIN0_TX	O2		ASCLIN0 output (aka: ATX0)
	IOM_MON2_12			IOM monitor input
	IOM_REF2_12			IOM reference input
	ERAY0_TXDA	O3		ERAY0 output
	ERAY0_TXDB	O4		ERAY0 output
	CAN1_TXD	O5		CAN node 1 output (aka: TXDCAN1)
	IOM_MON2_6			IOM monitor input
	IOM_REF2_6			IOM reference input
	ASCLIN0_SCLK	O6		ASCLIN0 output (aka: ASCLK0)
	CCU60_COUT62	O7		CCU60 output
	IOM_MON1_5			IOM monitor input
	IOM_REF1_1			IOM reference input

Table 2-7 Port 14 Functions (cont'd)

Ball	Symbol	Ctrl.	Buffer Type	Function
A15	P14.1	I	A1+ / HighZ / VDDP3	General-purpose input
	TIM0_4			GTM_TIN
	ASCLIN0_RXA			ASCLIN0 input (aka: ARX0A)
	CAN1_RXDB			CAN node 1 input (aka: RXDCAN1B)
	ERAY0_RXDA3			ERAY0 input
	SCU_REQ15			SCU input
	ERAY0_RXDB3			ERAY0 input
	SCU_EVRWUPA	AI		SCU input
	P14.1	O0		General-purpose output
	TOM0_4	O1		GTM_TOUT (= DTM1_OUT4)
	TOM1_4		GTM_TOUT (= DTM5_OUT4)	
	TOM0_7		GTM_TOUT (= DTM1_OUT7)	
	TOM1_7		GTM_TOUT (= DTM5_OUT7)	
	IOM_REF1_14		IOM reference input	
	ASCLIN0_TX	O2		ASCLIN0 output (aka: ATX0)
	IOM_MON2_12		IOM monitor input	
	IOM_REF2_12		IOM reference input	
	—	O3		Reserved
	—	O4		Reserved
	—	O5		Reserved
	—	O6		Reserved
	CCU60_COUT63	O7		CCU60 output
	IOM_MON1_6		IOM monitor input	
	IOM_REF1_0		IOM reference input	

Table 2-7 Port 14 Functions (cont'd)

Ball	Symbol	Ctrl.	Buffer Type	Function
E13	P14.2	I	A1 / PU / VDDP3	General-purpose input
	TIM0_5			GTM_TIN
	SCU_HWCFG2_EVR13			SCU input
	P14.2	O0		General-purpose output
	TOM0_5	O1		GTM_TOUT (= DTM1_OUT5)
	TOM1_5			GTM_TOUT (= DTM5_OUT5)
	TOM0_6N			GTM_TOUT (= DTM1_OUT6_N)
	TOM1_6N			GTM_TOUT (= DTM5_OUT6_N)
	IOM_REF1_15			IOM reference input
	—	O2		Reserved
	QSPI2_SLSO1	O3		QSPI2 output (aka: SLSO21)
	—	O4		Reserved
	—	O5		Reserved
	—	O6		Reserved
—	O7	Reserved		
B14	P14.3	I	A1 / PU / VDDP3	General-purpose input
	TIM0_6			GTM_TIN
	SCU_REQ10			SCU input
	SCU_HWCFG3_BMI			SCU input
	P14.3	O0		General-purpose output
	TOM0_6	O1		GTM_TOUT (= DTM1_OUT6)
	TOM1_6			GTM_TOUT (= DTM5_OUT6)
	IOM_REF2_4			IOM reference input
	—	O2		Reserved
	QSPI2_SLSO3	O3		QSPI2 output (aka: SLSO23)
	ASCLIN1_SLSO	O4		ASCLIN1 output (aka: ASLSO1)
	—	O5		Reserved
	—	O6		Reserved
	—	O7		Reserved

Table 2-7 Port 14 Functions (cont'd)

Ball	Symbol	Ctrl.	Buffer Type	Function
B15	P14.4	I	A1+ / HighZ / VDDP3	General-purpose input
	TIM0_7			GTM_TIN
	P14.4	O0		General-purpose output
	TOM0_7	O1		GTM_TOUT (= DTM1_OUT7)
	TOM1_7			GTM_TOUT (= DTM5_OUT7)
	TOM0_7N			GTM_TOUT (= DTM1_OUT7_N)
	TOM1_7N			GTM_TOUT (= DTM5_OUT7_N)
	IOM_REF2_8			IOM reference input
	—	O2		Reserved
	—	O3		Reserved
	—	O4		Reserved
	—	O5		Reserved
	—	O6		Reserved
	—	O7		Reserved
A14	P14.5	I	A1+ / HighZ / VDDP3	General-purpose input
	TIM0_0			GTM_TIN
	P14.5	O0		General-purpose output
	TOM0_0	O1		GTM_TOUT
	TOM1_0			GTM_TOUT
	IOM_REF2_11			IOM reference input
	—	O2		Reserved
	—	O3		Reserved
	—	O4		Reserved
	—	O5		Reserved
	ERAY0_TXDB	O6		ERAY0 output
	—	O7		Reserved

Table 2-7 Port 14 Functions (cont'd)

Ball	Symbol	Ctrl.	Buffer Type	Function
B13	P14.6	I	A1+ / PU / VDDP3	General-purpose input
	TIM0_1			GTM_TIN
	SCU_HWCFG0_DCLDO			SCU input
	QSPIO_MRSTD			QSPIO input (aka: MRST0D)
	P14.6	O0		General-purpose output
	TOM0_1	O1		GTM_TOUT
	TOM1_1			GTM_TOUT
	IOM_REF2_14	IOM reference input		
	—	O2		Reserved
	QSPI2_SLSO2	O3		QSPI2 output (aka: SLSO22)
	—	O4		Reserved
	—	O5		Reserved
	ERAY0_TXENB	O6		ERAY0 output
	—	O7		Reserved
D13	P14.7	I	A1 / HighZ / VDDP3	General-purpose input
	TIM0_0			GTM_TIN
	ERAY0_RXDB0			ERAY0 input
	P14.7	O0		General-purpose output
	TOM0_0	O1		GTM_TOUT
	IOM_REF2_15			IOM reference input
	ASCLIN0_RTS	O2		ASCLIN0 output (aka: ARTS0)
	QSPI2_SLSO4	O3		QSPI2 output (aka: SLSO24)
	—	O4		Reserved
	—	O5		Reserved
	—	O6		Reserved
	—	O7		Reserved

Package and Pinning Definitions PG-LFBGA-292-6 Package Variant Pin

Table 2-7 Port 14 Functions (cont'd)

Ball	Symbol	Ctrl.	Buffer Type	Function
A13	P14.8	I	A1 / HighZ / VDDP3	General-purpose input
	ASCLIN1_RXD			ASCLIN1 input (aka: ARX1D)
	CAN2_RXDD			CAN node 2 input (aka: RXDCAN2D)
	ERAY0_RXDA0			ERAY0 input
	P14.8	O0		General-purpose output
	TOM0_2	O1		GTM_TOUT
	—	O2		Reserved
	—	O3		Reserved
	—	O4		Reserved
	—	O5		Reserved
	—	O6		Reserved
	—	O7		Reserved

Table 2-8 Port 15 Functions

Ball	Symbol	Ctrl.	Buffer Type	Function
B20	P15.0	I	A1 / HighZ / VDDP3	General-purpose input
	P15.0	O0		General-purpose output
	TOM1_3	O1		GTM_TOUT
	TOM0_11			GTM_TOUT
	TOM0_7N			GTM_TOUT (= DTM1_OUT7_N)
	TOM1_7N			GTM_TOUT (= DTM5_OUT7_N)
	ASCLIN1_TX			O2
	IOM_MON2_13	O3		IOM monitor input
	IOM_REF2_13			IOM reference input
	QSPIO_SLSO13	O4		QSPIO output (aka: SLSO013)
	—	O5		Reserved
	CAN2_TXD	O6		CAN node 2 output (aka: TXDCAN2)
	IOM_MON2_7			IOM monitor input
	IOM_REF2_7			IOM reference input
	ASCLIN1_SCLK	O7		ASCLIN1 output (aka: ASCLK1)
	—			Reserved

Package and Pinning Definitions PG-LFBGA-292-6 Package Variant Pin

Table 2-8 Port 15 Functions (cont'd)

Ball	Symbol	Ctrl.	Buffer Type	Function
A18	P15.1	I	A1 / HighZ / VDDP3	General-purpose input
	ASCLIN1_RXA			ASCLIN1 input (aka: ARX1A)
	QSPI2_SLSIB			QSPI2 input (aka: SLSI2B)
	CAN2_RXDA			CAN node 2 input (aka: RXDCAN2A)
	SCU_REQ16			SCU input
	SCU_EVRWUPB	AI		SCU input
	P15.1	O0		General-purpose output
	TOM1_4	O1		GTM_TOUT (= DTM5_OUT4)
	TOM0_12			GTM_TOUT
	TOM0_4			GTM_TOUT (= DTM1_OUT4)
	TOM1_4			GTM_TOUT (= DTM5_OUT4)
	ASCLIN1_TX	O2		ASCLIN1 output (aka: ATX1)
	IOM_MON2_13			IOM monitor input
	IOM_REF2_13			IOM reference input
	QSPI2_SLSO5	O3		QSPI2 output (aka: SLSO25)
	—	O4		Reserved
	—	O5		Reserved
	—	O6		Reserved
—	O7	Reserved		
C19	P15.2	I	A1 / HighZ / VDDP3	General-purpose input
	QSPI2_MRSTE			QSPI2 input (aka: MRST2E)
	QSPI2_SLSIA			QSPI2 input (aka: SLSI2A)
	QSPI2_HSICINA			QSPI2 input (aka: HSIC2INA)
	P15.2	O0		General-purpose output
	TOM1_5	O1		GTM_TOUT (= DTM5_OUT5)
	TOM0_13			GTM_TOUT
	TOM0_4N			GTM_TOUT (= DTM1_OUT4_N)
	TOM1_4N			GTM_TOUT (= DTM5_OUT4_N)
	ASCLIN0_TX	O2		ASCLIN0 output (aka: ATX0)
	IOM_MON2_12			IOM monitor input
	IOM_REF2_12			IOM reference input
	QSPI2_SLSO0	O3		QSPI2 output (aka: SLSO20)
	—	O4		Reserved
	CAN1_TXD	O5		CAN node 1 output (aka: TXDCAN1)
	IOM_MON2_6	O6		IOM monitor input
	IOM_REF2_6			IOM reference input
	ASCLIN0_SCLK			ASCLIN0 output (aka: ASCLK0)
—	O7	Reserved		

Package and Pinning Definitions PG-LFBGA-292-6 Package Variant Pin

Table 2-8 Port 15 Functions (cont'd)

Ball	Symbol	Ctrl.	Buffer Type	Function
B17	P15.3	I	A1 / HighZ / VDDP3	General-purpose input
	ASCLIN0_RXB			ASCLIN0 input (aka: ARX0B)
	QSPI2_SCLKA			QSPI2 input (aka: SCLK2A)
	QSPI2_HSICINB			QSPI2 input (aka: HSIC2INB)
	CAN1_RXDA			CAN node 1 input (aka: RXDCAN1A)
	P15.3	O0		General-purpose output
	TOM1_6	O1		GTM_TOUT (= DTM5_OUT6)
	TOM0_14			GTM_TOUT
	TOM0_5			GTM_TOUT (= DTM1_OUT5)
	TOM1_5			GTM_TOUT (= DTM5_OUT5)
	ASCLIN0_TX	O2		ASCLIN0 output (aka: ATX0)
	IOM_MON2_12			IOM monitor input
	IOM_REF2_12			IOM reference input
	QSPI2_SCLK	O3		QSPI2 output (aka: SCLK2)
	—	O4		Reserved
	—	O5		Reserved
	—	O6		Reserved
—	O7	Reserved		
A17	P15.4	I	A1 / HighZ / VDDP3	General-purpose input
	QSPI2_MRSTA			QSPI2 input (aka: MRST2A)
	SCU_REQ0			SCU input
	P15.4	O0		General-purpose output
	TOM1_7	O1		GTM_TOUT (= DTM5_OUT7)
	TOM0_15			GTM_TOUT
	ASCLIN1_TX	O2		ASCLIN1 output (aka: ATX1)
	IOM_MON2_13			IOM monitor input
	IOM_REF2_13			IOM reference input
	QSPI2_MRST	O3		QSPI2 output (aka: MRST2)
	IOM_MON2_2			IOM monitor input
	IOM_REF2_2			IOM reference input
	—	O4		Reserved
	—	O5		Reserved
	—	O6		Reserved
	CCU60_CC62	O7		CCU60 output
	IOM_MON1_0			IOM monitor input
IOM_REF1_4	IOM reference input			

Package and Pinning Definitions PG-LFBGA-292-6 Package Variant Pin

Table 2-8 Port 15 Functions (cont'd)

Ball	Symbol	Ctrl.	Buffer Type	Function
E14	P15.5	I	A1 / HighZ / VDDP3	General-purpose input
	ASCLIN1_RXB			ASCLIN1 input (aka: ARX1B)
	QSPI2_MTSRA			QSPI2 input (aka: MTSR2A)
	SCU_REQ13			SCU input
	P15.5	O0		General-purpose output
	TOM0_0	O1		GTM_TOUT
	TOM1_0			GTM_TOUT
	TOM0_5N			GTM_TOUT (= DTM1_OUT5_N)
	TOM1_5N			GTM_TOUT (= DTM5_OUT5_N)
	ASCLIN1_TX	O2		ASCLIN1 output (aka: ATX1)
	IOM_MON2_13			IOM monitor input
	IOM_REF2_13			IOM reference input
	QSPI2_MTSR	O3		QSPI2 output (aka: MTSR2)
	—	O4		Reserved
	—	O5		Reserved
	—	O6		Reserved
	CCU60_CC61	O7		CCU60 output
IOM_MON1_1	IOM monitor input			
IOM_REF1_5	IOM reference input			
A16	P15.6	I	A1 / HighZ / VDDP3	General-purpose input
	TIM0_0			GTM_TIN
	QSPI2_MTSRB			QSPI2 input (aka: MTSR2B)
	P15.6	O0		General-purpose output
	TOM0_0	O1		GTM_TOUT
	TOM1_0			GTM_TOUT
	—	O2		Reserved
	QSPI2_MTSR	O3		QSPI2 output (aka: MTSR2)
	—	O4		Reserved
	QSPI2_SCLK	O5		QSPI2 output (aka: SCLK2)
	—	O6		Reserved
	CCU60_CC60	O7		CCU60 output
	IOM_MON1_2			IOM monitor input
	IOM_REF1_6			IOM reference input

Package and Pinning Definitions PG-LFBGA-292-6 Package Variant Pin

Table 2-8 Port 15 Functions (cont'd)

Ball	Symbol	Ctrl.	Buffer Type	Function
D15	P15.7	I	A1 / HighZ / VDDP3	General-purpose input
	TIM0_1			GTM_TIN
	QSPI2_MRSTB			QSPI2 input (aka: MRST2B)
	P15.7	O0		General-purpose output
	TOM0_1	O1		GTM_TOUT
	TOM1_1			GTM_TOUT
	—	O2		Reserved
	QSPI2_MRST	O3		QSPI2 output (aka: MRST2)
	IOM_MON2_2			IOM monitor input
	IOM_REF2_2			IOM reference input
	—	O4		Reserved
	—	O5		Reserved
	—	O6		Reserved
	CCU60_COUT60	O7		CCU60 output
	IOM_MON1_3			IOM monitor input
IOM_REF1_3	IOM reference input			
D14	P15.8	I	A1 / HighZ / VDDP3	General-purpose input
	TIM0_2			GTM_TIN
	QSPI2_SCLKB			QSPI2 input (aka: SCLK2B)
	SCU_REQ1			SCU input
	P15.8	O0		General-purpose output
	TOM0_2	O1		GTM_TOUT
	TOM1_2			GTM_TOUT
	—	O2		Reserved
	QSPI2_SCLK	O3		QSPI2 output (aka: SCLK2)
	—	O4		Reserved
	—	O5		Reserved
	—	O6		Reserved
	CCU60_COUT61	O7		CCU60 output
	IOM_MON1_4			IOM monitor input
	IOM_REF1_2			IOM reference input

Table 2-9 Port 20 Functions

Ball	Symbol	Ctrl.	Buffer Type	Function
H20	P20.0	I	A1 / HighZ / VDDP3	General-purpose input
	TIM0_6			GTM_TIN
	SCU_REQ9			SCU input
	OCDS_TGI0			OCDS input
	GPT120_T6EUDA			GPT120 input
	CAN11_RXDC			CAN1 node 1 input (aka: RXDCAN11C)
	CAN12_RXDC			CAN1 node 2 input (aka: RXDCAN12C)
	P20.0	O0		General-purpose output
	TOM0_6	O1		GTM_TOUT (= DTM1_OUT6)
	TOM1_6			GTM_TOUT (= DTM5_OUT6)
	—	O2		Reserved
	—	O3		Reserved
	—	O4		Reserved
	—	O5		Reserved
	—	O6		Reserved
—	O7	Reserved		
OCDS_TGO0	O	OCDS		
H19	P20.2	I	Input Only / PU / VDDP3	General-purpose input
	TESTMODE			Factory Test Mode Enable
G20	P20.3	I	A1 / HighZ / VDDP3	General-purpose input
	TIM0_4			GTM_TIN
	GPT120_T6INA			GPT120 input
	P20.3	O0		General-purpose output
	TOM1_12	O1		GTM_TOUT
	TOM0_4			GTM_TOUT (= DTM1_OUT4)
	IOM_MON1_14			IOM monitor input
	—	O2		Reserved
	QSPIO_SLSO9	O3		QSPIO output (aka: SLSO09)
	QSPI2_SLSO9	O4		QSPI2 output (aka: SLSO29)
	CAN12_TXD	O5		CAN1 node 2 output (aka: TXDCAN12)
	—	O6		Reserved
	—	O7		Reserved

Table 2-9 Port 20 Functions (cont'd)

Ball	Symbol	Ctrl.	Buffer Type	Function
F17	P20.6	I	A1 / HighZ / VDDP3	General-purpose input
	TIM0_6			GTM_TIN
	P20.6	O0		General-purpose output
	TOM1_10	O1		GTM_TOUT
	TOM0_10			GTM_TOUT
	IOM_MON1_15			IOM monitor input
	ASCLIN1_RTS	O2		ASCLIN1 output (aka: ARTS1)
	QSPI0_SLSO8	O3		QSPI0 output (aka: SLSO08)
	QSPI2_SLSO8	O4		QSPI2 output (aka: SLSO28)
	—	O5		Reserved
	—	O6		Reserved
—	O7	Reserved		
F19	P20.7	I	A1 / HighZ / VDDP3	General-purpose input
	TIM0_7			GTM_TIN
	ASCLIN1_CTSA			ASCLIN1 input (aka: ACTS1A)
	CAN0_RXDB			CAN node 0 input (aka: RXDCAN0B)
	P20.7	O0		General-purpose output
	TOM1_11	O1		GTM_TOUT
	TOM0_11			GTM_TOUT
	IOM_MON2_4			IOM monitor input
	—	O2		Reserved
	—	O3		Reserved
	—	O4		Reserved
	—	O5		Reserved
	—	O6		Reserved
	CCU61_COUT63	O7		CCU61 output
	IOM_MON1_7			IOM monitor input
IOM_REF1_7		IOM reference input		

Package and Pinning Definitions PG-LFBGA-292-6 Package Variant Pin

Table 2-9 Port 20 Functions (cont'd)

Ball	Symbol	Ctrl.	Buffer Type	Function	
F20	P20.8	I	A1 / HighZ / VDDP3	General-purpose input	
	TIM0_7			GTM_TIN	
	P20.8	O0		General-purpose output	
	TOM1_7	O1		GTM_TOUT (= DTM5_OUT7)	
	TOM0_7			GTM_TOUT (= DTM1_OUT7)	
	TOM0_4			GTM_TOUT (= DTM1_OUT4)	
	TOM1_4			GTM_TOUT (= DTM5_OUT4)	
	IOM_MON2_8			IOM monitor input	
	ASCLIN1_SLSO			O2	ASCLIN1 output (aka: ASLSO1)
	QSPI0_SLSO0			O3	QSPI0 output (aka: SLSO00)
	QSPI1_SLSO0	O4		QSPI1 output (aka: SLSO10)	
	CAN0_TXD	O5		CAN node 0 output (aka: TXDCAN0)	
	IOM_MON2_5			IOM monitor input	
	IOM_REF2_5			IOM reference input	
	SCU_WDT0LCK	O6		SCU output	
	CCU61_CC60	O7		CCU61 output	
	IOM_MON1_8			IOM monitor input	
	IOM_REF1_13			IOM reference input	
E17	P20.9	I	A1 / HighZ / VDDP3	General-purpose input	
	ASCLIN1_RXC			ASCLIN1 input (aka: ARX1C)	
	QSPI0_SLSIB			QSPI0 input (aka: SLSI0B)	
	SCU_REQ11			SCU input	
	CAN12_RXDE			CAN1 node 2 input (aka: RXDCAN12E)	
	P20.9	O0		General-purpose output	
	TOM1_13	O1		GTM_TOUT	
	TOM0_13			GTM_TOUT	
	TOM0_4N			GTM_TOUT (= DTM1_OUT4_N)	
	TOM1_4N			GTM_TOUT (= DTM5_OUT4_N)	
	IOM_MON2_11			IOM monitor input	
	—	O2		Reserved	
	QSPI0_SLSO1	O3		QSPI0 output (aka: SLSO01)	
	QSPI1_SLSO1	O4		QSPI1 output (aka: SLSO11)	
	—	O5		Reserved	
	SCU_WDTSLCK	O6		SCU output	
	CCU61_CC61	O7		CCU61 output	
	IOM_MON1_9			IOM monitor input	
IOM_REF1_12	IOM reference input				

Package and Pinning Definitions PG-LFBGA-292-6 Package Variant Pin

Table 2-9 Port 20 Functions (cont'd)

Ball	Symbol	Ctrl.	Buffer Type	Function
E19	P20.10	I	A1 / HighZ / VDDP3	General-purpose input
	P20.10	O0		General-purpose output
	TOM1_14	O1		GTM_TOUT
	TOM0_14			GTM_TOUT
	TOM0_5			GTM_TOUT (= DTM1_OUT5)
	TOM1_5			GTM_TOUT (= DTM5_OUT5)
	IOM_MON2_14			IOM monitor input
	ASCLIN1_TX			O2
	IOM_MON2_13	O2		IOM monitor input
	IOM_REF2_13			IOM reference input
	QSPI0_SLSO6			O3
	QSPI2_SLSO7	O4		QSPI2 output (aka: SLSO27)
	CAN12_TXD	O5		CAN1 node 2 output (aka: TXDCAN12)
	ASCLIN1_SCLK	O6		ASCLIN1 output (aka: ASCLK1)
	CCU61_CC62	O7		CCU61 output
	IOM_MON1_10	O7		IOM monitor input
	IOM_REF1_11			IOM reference input
E20	P20.11	I	A1+ / HighZ / VDDP3	General-purpose input
	QSPI0_SCLKA	O0		QSPI0 input (aka: SCLK0A)
	P20.11			General-purpose output
	TOM1_15	O1		GTM_TOUT
	TOM0_15			GTM_TOUT
	TOM0_5N			GTM_TOUT (= DTM1_OUT5_N)
	TOM1_5N			GTM_TOUT (= DTM5_OUT5_N)
	IOM_MON2_15			IOM monitor input
	—			O2
	QSPI0_SCLK	O3		QSPI0 output (aka: SCLK0)
	—	O4		Reserved
	CAN11_TXD	O5		CAN1 node 1 output (aka: TXDCAN11)
	—	O6		Reserved
	CCU61_COUT60	O7		CCU61 output
	IOM_MON1_11	O7		IOM monitor input
IOM_REF1_10	IOM reference input			

Package and Pinning Definitions PG-LFBGA-292-6 Package Variant Pin

Table 2-9 Port 20 Functions (cont'd)

Ball	Symbol	Ctrl.	Buffer Type	Function	
D19	P20.12	I	A1 / HighZ / VDDP3	General-purpose input	
	QSPIO_MRSTA			QSPIO input (aka: MRST0A)	
	CAN11_RXDH			CAN1 node 1 input (aka: RXDCAN11H)	
	IOM_PIN13			IOM pad input	
	P20.12	O0		General-purpose output	
	TOM1_0	O1		GTM_TOUT	
	TOM0_8		GTM_TOUT		
	TOM0_6		GTM_TOUT (= DTM1_OUT6)		
	TOM1_6		GTM_TOUT (= DTM5_OUT6)		
	IOM_MON0_13		IOM monitor input		
	—		O2		Reserved
	QSPIO_MRST		O3		QSPIO output (aka: MRST0)
	IOM_MON2_0	IOM monitor input			
	IOM_REF2_0	IOM reference input			
	QSPIO_MTSR	O4		QSPIO output (aka: MTSR0)	
	—	O5		Reserved	
	—	O6		Reserved	
	CCU61_COUT61	O7		CCU61 output	
	IOM_MON1_12		IOM monitor input		
	IOM_REF1_9		IOM reference input		
D20	P20.13	I	A1+ / HighZ / VDDP3	General-purpose input	
	QSPIO_SLSIA			QSPIO input (aka: SLSI0A)	
	CAN12_RXDH			CAN1 node 2 input (aka: RXDCAN12H)	
	IOM_PIN14			IOM pad input	
	P20.13	O0		General-purpose output	
	TOM1_1	O1		GTM_TOUT	
	TOM0_9		GTM_TOUT		
	TOM0_6N		GTM_TOUT (= DTM1_OUT6_N)		
	TOM1_6N		GTM_TOUT (= DTM5_OUT6_N)		
	IOM_MON0_14		IOM monitor input		
	—		O2		Reserved
	QSPIO_SLSO2		O3		QSPIO output (aka: SLSO02)
	QSPIO1_SLSO2	O4		QSPIO1 output (aka: SLSO12)	
	QSPIO_SCLK	O5		QSPIO output (aka: SCLK0)	
	—	O6		Reserved	
	CCU61_COUT62	O7		CCU61 output	
	IOM_MON1_13		IOM monitor input		
	IOM_REF1_8		IOM reference input		

Table 2-9 Port 20 Functions (cont'd)

Ball	Symbol	Ctrl.	Buffer Type	Function
C20	P20.14	I	A1+ / HighZ / VDDP3	General-purpose input
	QSPI0_MTSRA			QSPI0 input (aka: MTSR0A)
	IOM_PIN15			IOM pad input
	P20.14	O0		General-purpose output
	TOM1_2	O1		GTM_TOUT
	TOM0_10			GTM_TOUT
	TOM0_7			GTM_TOUT (= DTM1_OUT7)
	TOM1_7			GTM_TOUT (= DTM5_OUT7)
	IOM_MON0_15			IOM monitor input
	—	O2		Reserved
	QSPI0_MTSR	O3		QSPI0 output (aka: MTSR0)
	—	O4		Reserved
	CAN12_TXD	O5		CAN1 node 2 output (aka: TXDCAN12)
	—	O6		Reserved
	—	O7		Reserved

Table 2-10 Port 21 Functions

Ball	Symbol	Ctrl.	Buffer Type	Function
K19	P21.2	I	A1 / HighZ / VDDP3	General-purpose input
	TIM0_0			GTM_TIN
	SCU_EMGSTOPB			SCU input
	P21.2	O0		General-purpose output
	TOM0_0	O1		GTM_TOUT
	TOM1_0			GTM_TOUT
	TOM0_4			GTM_TOUT (= DTM1_OUT4)
	TOM1_4			GTM_TOUT (= DTM5_OUT4)
	—	O2		Reserved
	—	O3		Reserved
	—	O4		Reserved
	—	O5		Reserved
	—	O6		Reserved
—	O7	Reserved		

Table 2-10 Port 21 Functions (cont'd)

Ball	Symbol	Ctrl.	Buffer Type	Function	
J19	P21.3	I	A1 / HighZ / VDDP3	General-purpose input	
	TIM0_1			GTM_TIN	
	P21.3	O0		General-purpose output	
	TOM0_1	O1		GTM_TOUT	
	TOM1_1			GTM_TOUT	
	TOM0_4N			GTM_TOUT (= DTM1_OUT4_N)	
	TOM1_4N			GTM_TOUT (= DTM5_OUT4_N)	
	—			O2	Reserved
	—			O3	Reserved
	—	O4		Reserved	
	—	O5		Reserved	
	—	O6		Reserved	
	—	O7		Reserved	
	K20	P21.4		I	A1 / HighZ / VDDP3
TIM0_2			GTM_TIN		
P21.4		O0	General-purpose output		
TOM0_2		O1	GTM_TOUT		
TOM1_2			GTM_TOUT		
TOM0_5			GTM_TOUT (= DTM1_OUT5)		
TOM1_5			GTM_TOUT (= DTM5_OUT5)		
—			O2	Reserved	
—			O3	Reserved	
—		O4	Reserved		
—		O5	Reserved		
—		O6	Reserved		
—		O7	Reserved		

Table 2-10 Port 21 Functions (cont'd)

Ball	Symbol	Ctrl.	Buffer Type	Function
J20	P21.5	I	A1 / HighZ / VDDP3	General-purpose input
	TIM0_3			GTM_TIN
	P21.5	O0		General-purpose output
	TOM0_3	O1		GTM_TOUT
	TOM1_3			GTM_TOUT
	TOM0_5N			GTM_TOUT (= DTM1_OUT5_N)
	TOM1_5N			GTM_TOUT (= DTM5_OUT5_N)
	—	O2		Reserved
	—	O3		Reserved
	—	O4		Reserved
	—	O5		Reserved
	—	O6		Reserved
	—	O7		Reserved
	H17	P21.6		I
TIM0_4		GTM_TIN		
TDI		OCDS input		
OCDS_TGI2		OCDS input		
GPT120_T5EUDA		GPT120 input		
P21.6		O0	General-purpose output	
TOM0_4		O1	GTM_TOUT (= DTM1_OUT4)	
TOM1_4			GTM_TOUT (= DTM5_OUT4)	
—		O2	Reserved	
—		O3	Reserved	
—		O4	Reserved	
—		O5	Reserved	
—		O6	Reserved	
GPT120_T3OUT		O7	GPT120 output	
OCDS_TGO2	O	OCDS		

Table 2-10 Port 21 Functions (cont'd)

Ball	Symbol	Ctrl.	Buffer Type	Function
H16	P21.7	I	A1+ / PU / VDDP3	General-purpose input
	TIM0_5			GTM_TIN
	OCDS_DAP2			OCDS input
	OCDS_TGI3			OCDS input
	GPT120_T5INA			GPT120 input
	P21.7			O0
	TOM0_5	O1	GTM_TOUT (= DTM1_OUT5)	
	TOM1_5		GTM_TOUT (= DTM5_OUT5)	
	—	O2	Reserved	
	—	O3	Reserved	
	—	O4	Reserved	
	—	O5	Reserved	
	—	O6	Reserved	
	GPT120_T6OUT	O7	GPT120 output	
	OCDS_TGO3	O	OCDS	
	OCDS_DAP2	O	OCDS Output	
TDO	O	JTAG Output		

Table 2-11 Port 22 Functions

Ball	Symbol	Ctrl.	Buffer Type	Function
P20	P22.0	I	A1 / HighZ / VDDP3	General-purpose input
	TIM0_1			GTM_TIN
	QSPI3_MTSRE			QSPI3 input (aka: MTSR3E)
	P22.0	O0	General-purpose output	
	TOM0_9	O1	GTM_TOUT	
	TOM1_1		GTM_TOUT	
	—	O2	Reserved	
	QSPI3_MTSR	O3	QSPI3 output (aka: MTSR3)	
	—	O4	Reserved	
	—	O5	Reserved	
	—	O6	Reserved	
	—	O7	Reserved	

Package and Pinning Definitions PG-LFBGA-292-6 Package Variant Pin

Table 2-11 Port 22 Functions (cont'd)

Ball	Symbol	Ctrl.	Buffer Type	Function
P19	P22.1	I	A1 / HighZ / VDDP3	General-purpose input
	TIM0_0			GTM_TIN
	QSPI3_MRSTE			QSPI3 input (aka: MRST3E)
	P22.1	O0		General-purpose output
	TOM0_8	O1		GTM_TOUT
	TOM1_0			GTM_TOUT
	TOM0_6			GTM_TOUT (= DTM1_OUT6)
	TOM1_6			GTM_TOUT (= DTM5_OUT6)
	—	O2		Reserved
	QSPI3_MRST	O3		QSPI3 output (aka: MRST3)
	IOM_MON2_3			IOM monitor input
	IOM_REF2_3			IOM reference input
	—	O4		Reserved
	—	O5		Reserved
	—	O6		Reserved
—	O7	Reserved		
R20	P22.2	I	A1 / HighZ / VDDP3	General-purpose input
	TIM0_3			GTM_TIN
	QSPI3_SLSID			QSPI3 input (aka: SLSI3D)
	P22.2	O0		General-purpose output
	TOM0_11	O1		GTM_TOUT
	TOM1_3			GTM_TOUT
	TOM0_6N			GTM_TOUT (= DTM1_OUT6_N)
	TOM1_6N			GTM_TOUT (= DTM5_OUT6_N)
	—	O2		Reserved
	QSPI3_SLSO12	O3		QSPI3 output (aka: SLSO312)
	—	O4		Reserved
	—	O5		Reserved
	—	O6		Reserved
	—	O7		Reserved

Package and Pinning Definitions PG-LFBGA-292-6 Package Variant Pin

Table 2-11 Port 22 Functions (cont'd)

Ball	Symbol	Ctrl.	Buffer Type	Function
R19	P22.3	I	A1 / HighZ / VDDP3	General-purpose input
	TIM0_4			GTM_TIN
	QSPI3_SCLKE			QSPI3 input (aka: SCLK3E)
	P22.3	O0		General-purpose output
	TOM0_12	O1		GTM_TOUT
	TOM1_4			GTM_TOUT (= DTM5_OUT4)
	TOM0_7			GTM_TOUT (= DTM1_OUT7)
	TOM1_7			GTM_TOUT (= DTM5_OUT7)
	—	O2		Reserved
	QSPI3_SCLK	O3		QSPI3 output (aka: SCLK3)
	—	O4		Reserved
	—	O5		Reserved
	—	O6		Reserved
	—	O7		Reserved
P16	P22.4	I	A1 / HighZ / VDDP3	General-purpose input
	P22.4	O0		General-purpose output
	TOM0_7N	O1		GTM_TOUT (= DTM1_OUT7_N)
	TOM1_7N			GTM_TOUT (= DTM5_OUT7_N)
	—	O2		Reserved
	—	O3		Reserved
	QSPI0_SLSO12	O4		QSPI0 output (aka: SLSO012)
	—	O5		Reserved
	—	O6		Reserved
	—	O7		Reserved

Table 2-12 Port 23 Functions

Ball	Symbol	Ctrl.	Buffer Type	Function
U19	P23.1	I	A1+ / HighZ / VDDP3	General-purpose input
	TIM0_6			GTM_TIN
	P23.1	O0		General-purpose output
	TOM0_6	O1		GTM_TOUT (= DTM1_OUT6)
	TOM0_15			GTM_TOUT
	ASCLIN1_RTS	O2		ASCLIN1 output (aka: ARTS1)
	QSPI3_SLSO13	O3		QSPI3 output (aka: SLSO313)
	GTM_CLK0	O4		GTM output
	SCU_EXTCLK1	O5		SCU output
	SCU_EXTCLK0	O6		SCU output
	—	O7		Reserved

Table 2-13 Port 33 Functions

Ball	Symbol	Ctrl.	Buffer Type	Function
W10	P33.0	I	A1 / HighZ / VDDP3	General-purpose input
	TIM0_4			GTM_TIN
	IOM_PIN0			IOM pad input
	P33.0	O0		General-purpose output
	TOM0_4	O1		GTM_TOUT (= DTM1_OUT4)
	TOM1_4			GTM_TOUT (= DTM5_OUT4)
	IOM_MON0_0	O2		IOM monitor input
	—			Reserved
	—			Reserved
	—	O3		Reserved
	—	O4		Reserved
	—	O5		Reserved
	VADC_G1BFL0	O6		VADC output
—	O7	Reserved		

Table 2-13 Port 33 Functions (cont'd)

Ball	Symbol	Ctrl.	Buffer Type	Function
Y10	P33.1	I	A1 / HighZ / VDDP3	General-purpose input
	TIM0_5			GTM_TIN
	IOM_PIN1			IOM pad input
	P33.1	O0		General-purpose output
	TOM0_5	O1		GTM_TOUT (= DTM1_OUT5)
	TOM1_5			GTM_TOUT (= DTM5_OUT5)
	IOM_MON0_1	IOM monitor input		
	—	O2		Reserved
	—	O3		Reserved
	—	O4		Reserved
	VADC_EMUX02	O5		VADC output
	VADC_G1BFL1	O6		VADC output
	—	O7		Reserved
W11	P33.2	I	A1 / HighZ / VDDP3	General-purpose input
	TIM0_6			GTM_TIN
	IOM_PIN2			IOM pad input
	P33.2	O0		General-purpose output
	TOM0_6	O1		GTM_TOUT (= DTM1_OUT6)
	TOM1_6			GTM_TOUT (= DTM5_OUT6)
	IOM_MON0_2	IOM monitor input		
	—	O2		Reserved
	—	O3		Reserved
	—	O4		Reserved
	VADC_EMUX01	O5		VADC output
	VADC_G1BFL2	O6		VADC output
	CCU61_COUT63	O7		CCU61 output
IOM_MON1_7	IOM monitor input			
IOM_REF1_7	IOM reference input			

Table 2-13 Port 33 Functions (cont'd)

Ball	Symbol	Ctrl.	Buffer Type	Function
Y11	P33.3	I	A1 / HighZ / VDDP3	General-purpose input
	TIM0_7			GTM_TIN
	IOM_PIN3			IOM pad input
	P33.3			O0
	TOM0_7	O1		GTM_TOUT (= DTM1_OUT7)
	TOM1_7			GTM_TOUT (= DTM5_OUT7)
	IOM_MON0_3			IOM monitor input
	—	O2		Reserved
	—	O3		Reserved
	—	O4		Reserved
	VADC_EMUX00	O5		VADC output
	VADC_G1BFL3	O6		VADC output
	CCU61_CC60	O7		CCU61 output
	IOM_MON1_8			IOM monitor input
IOM_REF1_13	IOM reference input			
W12	P33.4	I	A1 / HighZ / VDDP3	General-purpose input
	TIM0_0			GTM_TIN
	CCU61_CTRAPC			CCU61 input
	IOM_PIN4			IOM pad input
	P33.4	O0		General-purpose output
	TOM0_0	O1		GTM_TOUT
	TOM1_0			GTM_TOUT
	IOM_MON0_4			IOM monitor input
	—	O2		Reserved
	—	O3		Reserved
	—	O4		Reserved
	VADC_EMUX12	O5		VADC output
	VADC_G0BFL0	O6		VADC output
	—	O7		Reserved

Table 2-13 Port 33 Functions (cont'd)

Ball	Symbol	Ctrl.	Buffer Type	Function
Y12	P33.5	I	A1 / HighZ / VDDP3	General-purpose input
	TIM0_1			GTM_TIN
	CCU61_CCPOS2C			CCU61 input
	GPT120_T4EUDB			GPT120 input
	IOM_PIN5			IOM pad input
	P33.5	O0		General-purpose output
	TOM0_1	O1		GTM_TOUT
	TOM1_1			GTM_TOUT
	TOM0_5			GTM_TOUT (= DTM1_OUT5)
	TOM1_5			GTM_TOUT (= DTM5_OUT5)
	IOM_MON0_5			IOM monitor input
	QSPI0_SLSO7	O2		QSPI0 output (aka: SLSO07)
	QSPI1_SLSO7	O3		QSPI1 output (aka: SLSO17)
	—	O4		Reserved
	VADC_EMUX11	O5		VADC output
	VADC_G0BFL1	O6		VADC output
	CCU61_CC60	O7		CCU61 output
	IOM_MON1_8			IOM monitor input
	IOM_REF1_13			IOM reference input

Table 2-13 Port 33 Functions (cont'd)

Ball	Symbol	Ctrl.	Buffer Type	Function
W13	P33.6	I	A1 / HighZ / VDDP3	General-purpose input
	TIM0_2			GTM_TIN
	ASCLIN1_RXF			ASCLIN1 input (aka: ARX1F)
	CCU61_CCPOS1C			CCU61 input
	GPT120_T2EUDB			GPT120 input
	CAN10_RXDH			CAN1 node 0 input (aka: RXDCAN10H)
	IOM_PIN6			IOM pad input
	P33.6	O0		General-purpose output
	TOM0_2	O1		GTM_TOUT
	TOM1_2			GTM_TOUT
	TOM0_5N			GTM_TOUT (= DTM1_OUT5_N)
	TOM1_5N			GTM_TOUT (= DTM5_OUT5_N)
	IOM_MON0_6			IOM monitor input
	—			O2
	—	O3		Reserved
	ASCLIN1_TX	O4		ASCLIN1 output (aka: ATX1)
	IOM_MON2_13			IOM monitor input
	IOM_REF2_13			IOM reference input
	VADC_EMUX10			O5
	VADC_G0BFL2	O6		VADC output
	CCU61_CC61	O7		CCU61 output
	IOM_MON1_9			IOM monitor input
	IOM_REF1_12			IOM reference input
HSM_HSM1	O		HSM output	

Table 2-13 Port 33 Functions (cont'd)

Ball	Symbol	Ctrl.	Buffer Type	Function
Y13	P33.7	I	A1+ / HighZ / VDDP3	General-purpose input
	TIM0_3			GTM_TIN
	CAN0_RXDE			CAN node 0 input (aka: RXDCAN0E)
	SCU_REQ8			SCU input
	CCU61_CCPOS0C			CCU61 input
	GPT120_T2INB			GPT120 input
	IOM_PIN7			IOM pad input
	P33.7	O0	General-purpose output	
	TOM0_3	O1	GTM_TOUT	
	TOM1_3		GTM_TOUT	
	TOM0_6		GTM_TOUT (= DTM1_OUT6)	
	TOM1_6		GTM_TOUT (= DTM5_OUT6)	
	IOM_MON0_7		IOM monitor input	
	—	O2	Reserved	
	QSPI3_SLSO7	O3	QSPI3 output (aka: SLSO37)	
	—	O4	Reserved	
	CAN10_TXD	O5	CAN1 node 0 output (aka: TXDCAN10)	
	VADC_G0BFL3	O6	VADC output	
	CCU61_COUT60	O7	CCU61 output	
	IOM_MON1_11		IOM monitor input	
	IOM_REF1_10		IOM reference input	
HSM_HSM2	O	HSM output		

Table 2-13 Port 33 Functions (cont'd)

Ball	Symbol	Ctrl.	Buffer Type	Function
W14	P33.8	I	A1+ / HighZ / VDDP3	General-purpose input
	TIM0_4			GTM_TIN
	SCU_EMGSTOPA			SCU input
	IOM_PIN8			IOM pad input
	P33.8	O0		General-purpose output
	TOM0_4	O1		GTM_TOUT (= DTM1_OUT4)
	TOM1_4			GTM_TOUT (= DTM5_OUT4)
	TOM0_6N			GTM_TOUT (= DTM1_OUT6_N)
	TOM1_6N			GTM_TOUT (= DTM5_OUT6_N)
	IOM_MON0_8	O2		IOM monitor input
	—			Reserved
	QSPI3_SLSO2	O3		QSPI3 output (aka: SLSO32)
	—	O4		Reserved
	CAN0_TXD	O5		CAN node 0 output (aka: TXDCAN0)
	IOM_MON2_5			IOM monitor input
	IOM_REF2_5			IOM reference input
	—	O6		Reserved
	CCU61_COUT62	O7		CCU61 output
	IOM_MON1_13			IOM monitor input
	IOM_REF1_8			IOM reference input
SMU_FSP	O	SMU		

Package and Pinning Definitions PG-LFBGA-292-6 Package Variant Pin

Table 2-13 Port 33 Functions (cont'd)

Ball	Symbol	Ctrl.	Buffer Type	Function	
Y14	P33.9	I	A1 / HighZ / VDDP3	General-purpose input	
	TIM0_1			GTM_TIN	
	QSPI3_HSICINA			QSPI3 input (aka: HSIC3INA)	
	IOM_PIN9			IOM pad input	
	P33.9	O0		General-purpose output	
	TOM0_1	O1		GTM_TOUT	
	TOM1_1			GTM_TOUT	
	TOM0_7			GTM_TOUT (= DTM1_OUT7)	
	TOM1_7			GTM_TOUT (= DTM5_OUT7)	
	IOM_MON0_9			IOM monitor input	
	—			O2	Reserved
	QSPI3_SLSO1			O3	QSPI3 output (aka: SLSO31)
	—			O4	Reserved
	—	O5		Reserved	
	—	O6		Reserved	
	CCU61_CC62	O7		CCU61 output	
	IOM_MON1_10			IOM monitor input	
	IOM_REF1_11			IOM reference input	
W15	P33.10	I	A1+ / HighZ / VDDP3	General-purpose input	
	TIM0_0			GTM_TIN	
	QSPI3_SLSIC			QSPI3 input (aka: SLSI3C)	
	QSPI3_HSICINB			QSPI3 input (aka: HSIC3INB)	
	IOM_PIN10	IOM pad input			
	P33.10	O0		General-purpose output	
	TOM0_0	O1		GTM_TOUT	
	TOM1_0			GTM_TOUT	
	TOM0_7N			GTM_TOUT (= DTM1_OUT7_N)	
	TOM1_7N			GTM_TOUT (= DTM5_OUT7_N)	
	IOM_MON0_10			IOM monitor input	
	QSPI1_SLSO6			O2	QSPI1 output (aka: SLSO16)
	QSPI3_SLSO11			O3	QSPI3 output (aka: SLSO311)
	ASCLIN1_SLSO			O4	ASCLIN1 output (aka: ASLSO1)
	GTM_CLK1	O5		GTM output	
	SCU_EXTCLK1	O6		SCU output	
	CCU61_COUT61	O7		CCU61 output	
	IOM_MON1_12			IOM monitor input	
	IOM_REF1_9			IOM reference input	

Table 2-13 Port 33 Functions (cont'd)

Ball	Symbol	Ctrl.	Buffer Type	Function
Y15	P33.11	I	A1 / HighZ / VDDP3	General-purpose input
	TIM0_2			GTM_TIN
	QSPI3_SCLKD			QSPI3 input (aka: SCLK3D)
	SCU_REQ17			SCU input
	IOM_PIN11			IOM pad input
	P33.11			O0
	TOM0_2	O1		GTM_TOUT
	TOM1_2			GTM_TOUT
	IOM_MON0_11			IOM monitor input
	ASCLIN1_SCLK			O2
	QSPI3_SCLK	O3		QSPI3 output (aka: SCLK3)
	—	O4		Reserved
	—	O5		Reserved
	SMPS_DCDCSYNC	O6		SCU output
	CCU61_CC61	O7		CCU61 output
	IOM_MON1_9			IOM monitor input
	IOM_REF1_12			IOM reference input
SMPS_DCDCSYNC	O	SCU output		
W16	P33.12	I	A1 / HighZ / VDDP3	General-purpose input
	TIM0_0			GTM_TIN
	QSPI3_MTSRD			QSPI3 input (aka: MTSR3D)
	IOM_PIN12			IOM pad input
	P33.12	O0		General-purpose output
	TOM1_12	O1		GTM_TOUT
	TOM0_12			GTM_TOUT
	IOM_MON0_12			IOM monitor input
	ASCLIN1_TX			O2
	IOM_MON2_13			IOM monitor input
	IOM_REF2_13			IOM reference input
	QSPI3_MTSR	O3		QSPI3 output (aka: MTSR3)
	ASCLIN1_SCLK	O4		ASCLIN1 output (aka: ASCLK1)
	—	O5		Reserved
	—	O6		Reserved
	CCU61_COUT60	O7		CCU61 output
	IOM_MON1_11			IOM monitor input
IOM_REF1_10	IOM reference input			

Table 2-14 Port 34 Functions

Ball	Symbol	Ctrl.	Buffer Type	Function
U10	P34.0	I	A1 / HighZ / VDDP3	General-purpose input
	P34.0	O0		General-purpose output
	TOM1_12	O1		GTM_TOUT
	—	O2		Reserved
	—	O3		Reserved
	—	O4		Reserved
	—	O5		Reserved
	—	O6		Reserved
	—	O7		Reserved
U11	P34.1	I	A1 / HighZ / VDDP3	General-purpose input
	P34.1	O0		General-purpose output
	TOM1_13	O1		GTM_TOUT
	ASCLIN0_TX	O2		ASCLIN0 output (aka: ATX0)
	IOM_MON2_12			IOM monitor input
	IOM_REF2_12			IOM reference input
	—	O3		Reserved
	CAN0_TXD	O4		CAN node 0 output (aka: TXDCAN0)
	IOM_MON2_5	O5		IOM monitor input
	IOM_REF2_5			IOM reference input
	—			Reserved
	—	O6		Reserved
	—	O7		Reserved
T12	P34.2	I	A1 / HighZ / VDDP3	General-purpose input
	ASCLIN0_RXD			ASCLIN0 input (aka: ARX0D)
	CAN0_RXDG			CAN node 0 input (aka: RXDCAN0G)
	P34.2	O0		General-purpose output
	TOM1_14	O1		GTM_TOUT
	—	O2		Reserved
	—	O3		Reserved
	—	O4		Reserved
	—	O5		Reserved
	—	O6		Reserved
	—	O7		Reserved

Package and Pinning Definitions PG-LFBGA-292-6 Package Variant Pin

Table 2-14 Port 34 Functions (cont'd)

Ball	Symbol	Ctrl.	Buffer Type	Function
U12	P34.3	I	A1 / HighZ / VDDP3	General-purpose input
	ASCLIN1_CTSB			ASCLIN1 input (aka: ACTS1B)
	P34.3	O0		General-purpose output
	TOM1_15	O1		GTM_TOUT
	—	O2		Reserved
	—	O3		Reserved
	QSPI2_SLSO10	O4		QSPI2 output (aka: SLSO210)
	—	O5		Reserved
	—	O6		Reserved
	—	O7		Reserved

Table 2-15 Port 40 Functions

Ball	Symbol	Ctrl.	Buffer Type	Function
W9	P40.0	I	S / VDDM	General-purpose input
	VADCG0_0	AI		VADC input channel 0 of group 0
Y9	P40.1	I	S / VDDM	General-purpose input
	VADCG0_1	AI		VADC input channel 1 of group 0 (with multiplexer diagnostics)
W8	P40.2	I	S / VDDM	General-purpose input
	VADCG0_2	AI		VADC input channel 2 of group 0 (with multiplexer diagnostics)
Y8	P40.3	I	S / VDDM	General-purpose input
	VADCG0_3	AI		VADC input channel 3 of group 0
W7	P40.4	I	S / VDDM	General-purpose input
	VADCG0_4	AI		VADC input channel 4 of group 0
W6	P40.5	I	S / VDDM	General-purpose input
	VADCG0_5	AI		VADC input channel 5 of group 0
W5	P40.6	I	S / VDDM	General-purpose input
	VADCG0_6	AI		VADC input channel 6 of group 0
W4	P40.7	I	S / VDDM	General-purpose input
	VADCG0_7	AI		VADC input channel 7 of group 0 (with pull down diagnostics)
W3	P40.8	I	S / VDDM	General-purpose input
	VADCG0_8	AI		VADC input channel 8 of group 0
Y3	P40.9	I	S / VDDM	General-purpose input
	VADCG0_9	AI		VADC input channel 9 of group 0 (with multiplexer diagnostics)

Package and Pinning Definitions PG-LFBGA-292-6 Package Variant Pin

Table 2-15 Port 40 Functions (cont'd)

Ball	Symbol	Ctrl.	Buffer Type	Function
Y2	P40.10	I	S / VDDM	General-purpose input
	VADCG0_10	AI		VADC input channel 10 of group 0 (with multiplexer diagnostics)
W1	P40.11	I	S / VDDM	General-purpose input
	SENT_SENT0A			SENT input
	CCU60_CCPOS0D			CCU60 input
	VADCG0_11	AI	VADC input channel 11 of group 0	

Table 2-16 Port 41 Functions

Ball	Symbol	Ctrl.	Buffer Type	Function
V2	P41.0	I	S / VDDM	General-purpose input
	SENT_SENT1A			SENT input
	CCU60_CCPOS1B			CCU60 input
	VADCG1_0	AI		VADC input channel 0 of group 1
V1	P41.1	I	S / VDDM	General-purpose input
	VADCG1_1	AI		VADC input channel 1 of group 1 (with multiplexer diagnostics)
U2	P41.2	I	S / VDDM	General-purpose input
	SENT_SENT2A			SENT input
	CCU61_CCPOS1B			CCU61 input
	VADCG1_2	AI	VADC input channel 2 of group 1 (with multiplexer diagnostics)	
U1	P41.3	I	S / VDDM	General-purpose input
	SENT_SENT3A			SENT input
	CCU61_CCPOS1D			CCU61 input
	VADCG1_3	AI		VADC input channel 3 of group 1 (with pull down diagnostics)
R1	P41.4	I	S / VDDM	General-purpose input
	VADCG1_4	AI		VADC input channel 4 of group 1
R2	P41.5	I	S / VDDM	General-purpose input
	VADCG1_5	AI		VADC input channel 5 of group 1
P2	P41.6	I	S / VDDM	General-purpose input
	VADCG1_6	AI		VADC input channel 6 of group 1
P1	P41.7	I	S / VDDM	General-purpose input
	VADCG1_7	AI		VADC input channel 7 of group 1
N1	P41.8	I	S / VDDM	General-purpose input
	VADCG1_8	AI		VADC input channel 8 of group 1

Package and Pinning Definitions PG-LFBGA-292-6 Package Variant Pin

Table 2-16 Port 41 Functions (cont'd)

Ball	Symbol	Ctrl.	Buffer Type	Function
N2	P41.9	I	S / VDDM	General-purpose input
	VADCG1_9	AI		VADC input channel 9 of group 1 (with multiplexer diagnostics)
M1	P41.10	I	S / VDDM	General-purpose input
	VADCG1_10	AI		VADC input channel 10 of group 1 (with multiplexer diagnostics)
M2	P41.11	I	S / VDDM	General-purpose input
	VADCG1_11	AI		VADC input channel 11 of group 1

Table 2-17 System I/O

Ball	Symbol	Ctrl.	Buffer Type	Function
M20	XTAL1	I	VDDP3	Main Oscillator/PLL/Clock Generator Input
M19	XTAL2	O	VDDP3	Main Oscillator/PLL/Clock Generator Output
K16	TMS/DAP1	I	A1+ / PD / VDDP3	Debug Interface
	DAP1	I/O	VDDP3	Device Access Port Line 1
L19	$\overline{\text{TRST}}$	I	Input Only / PD / VDDP3	JTAG Module Reset/Enable Input
J16	TCK/DAP0	I	Input Only / PD / VDDP3	OCDS input
	DAP0	I	VDDP3	Device Access Port Line 0
G16	$\overline{\text{ESR1}}$	I/O	A1+ / PU / VDDP3	SCU input
	EVRWUP	I	VDDP3	EVR Wakeup Pin
G17	$\overline{\text{PORST}}$	I	Input Only / PD / VDDP3	Power On Reset Additional strong PD in case of power fail.
F16	$\overline{\text{ESR0}}$	I/O	A1+ / OD / VDDP3	SCU input/output
	EVRWUP	I	VDDP3	EVR Wakeup Pin

Table 2-18 Supply

Ball	Symbol	Ctrl.	Buffer Type	Function
Y7	V _{AGND}	I	—	Negative Analog Reference Voltage 0
Y6	V _{AREF}	I	—	Positive Analog Reference Voltage 0

Table 2-18 Supply (cont'd)

Ball	Symbol	Ctrl.	Buffer Type	Function
H7, G8, P8, N7, P13, N14, H14, G13	V_{DD}	I	—	Digital Core Power Supply (1.3V)
A2, B3, W20, V19, T11, A19, B18, D16, E15, D5	V_{DDP3}	I	—	Digital I/O Power Supply (3.3V)
Y4	V_{SSM}	I	—	Analog Ground for VDDM
Y5	V_{DDM}	I	—	ADC Power Supply (5.0V)
M14, L14, J14, M13, L13, K13, J13	V_{SS}	I	—	Digital Core Ground (0V)
P12, N12, L12, K12, H12, G12	V_{SS}	I	—	Digital Core Ground (0V)
P11, N11, M11, L11, K11, J11, H11, G11	V_{SS}	I	—	Digital Core Ground (0V)

Table 2-18 Supply (cont'd)

Ball	Symbol	Ctrl.	Buffer Type	Function
P10, N10, M10, L10, K10, J10, H10, G10	V _{SS}	I	—	Digital Core Ground (0V)
P9, N9, L9, K9, H9, G9	V _{SS}	I	—	Digital Core Ground (0V)
M8, L8, K8, J8, M7, L7, K7, J7	V _{SS}	I	—	Digital Core Ground (0V)
Y20, W19, U17, T16, A20, B19, D17, E16, B2, D4, E5	V _{SS}	I	—	Digital Core Ground (0V)
L20	V _{SS}	I	—	Digital Core Ground (0V)
N19	V _{DD}	I	—	Digital Core Power Supply (1.3V) This pin supplies also the main XTAL Oscillator/PLL (1.3V). A higher decoupling capacitor is therefore recommended to the VSS pin for better noise immunity.
N20	V _{DDP3}	I	—	Digital I/O Power Supply (3.3V) This pin supplies also the main XTAL Oscillator/PLL (3.3V). A higher decoupling capacitor is therefore recommended to the VSS pin for better noise immunity.

Table 2-18 Supply (cont'd)

Ball	Symbol	Ctrl.	Buffer Type	Function
A1, L1, T1, Y1, T2, W2, A3, B4, E4, F4, G4, H4, L4, M4, N4, P4, R4, T4, U4, F5, G5, H5, J5, K5, L5, M5, N5, P5, R5, T5, U5	NC	I	—	Not connected These pins are reserved for future extensions and shall not be connected externally.

Table 2-18 Supply (cont'd)

Ball	Symbol	Ctrl.	Buffer Type	Function
B6, D6, E6, T6, U6, A7, D7, T7, U7, D8, E8, T8, U8, E9, T9, U9, D10, E10, T10, D11, E11, D12, E12, T13, U13, K14, T14, U14	NC	I	—	Not connected These pins are reserved for future extensions and shall not be connected externally.

Table 2-18 Supply (cont'd)

Ball	Symbol	Ctrl.	Buffer Type	Function
T15, U15, L16, M16, N16, R16, U16, Y16, J17, K17, L17, M17, N17, P17, R17, T17, W17, W18, G19, T19, Y19, T20, U20, V20	NC	I	—	Not connected These pins are reserved for future extensions and shall not be connected externally.

2.1.2 Pull-Up/Pull-Down Reset Behavior of the Pins

Table 2-19 List of Pull-Up/Pull-Down Reset Behavior of the Pins

Pins	$\overline{\text{PORST}} = 0$	$\overline{\text{PORST}} = 1$
all GPIOs	High-Z	
TDI, $\overline{\text{TESTMODE}}$	Pull-up	
$\overline{\text{PORST}}^{1)}$	Pull-down with I_{PORST} relevant	Pull-down with I_{PDLI} relevant
$\overline{\text{TRST}}$, TCK, TMS	Pull-down	
ESR0	The open-drain driver is used to drive low. ²⁾	Pull-up ³⁾
ESR1	Pull-up ³⁾	
P14.2, P14.3, P14.6	Pull-up	
P21.7 / TDO	Pull-up	High-Z/Pull-up ⁴⁾

- 1) Pull-down with I_{PORST} relevant is always activated when a primary supply monitor detects a violation.
- 2) Valid additionally after deactivation of $\overline{\text{PORST}}$ until the internal reset phase has finished. See the SCU chapter for details.
- 3) See the SCU_IOCRR register description.
- 4) Depends on JTAG/DAP selection with $\overline{\text{TRST}}$.

2.2 PG-TQFP-144-27 Package Variant Pin Configuration of TC23x-ADAS

Figure 2-1 is showing the TC23x pinout for the package variant: PG-TQFP-144-27.

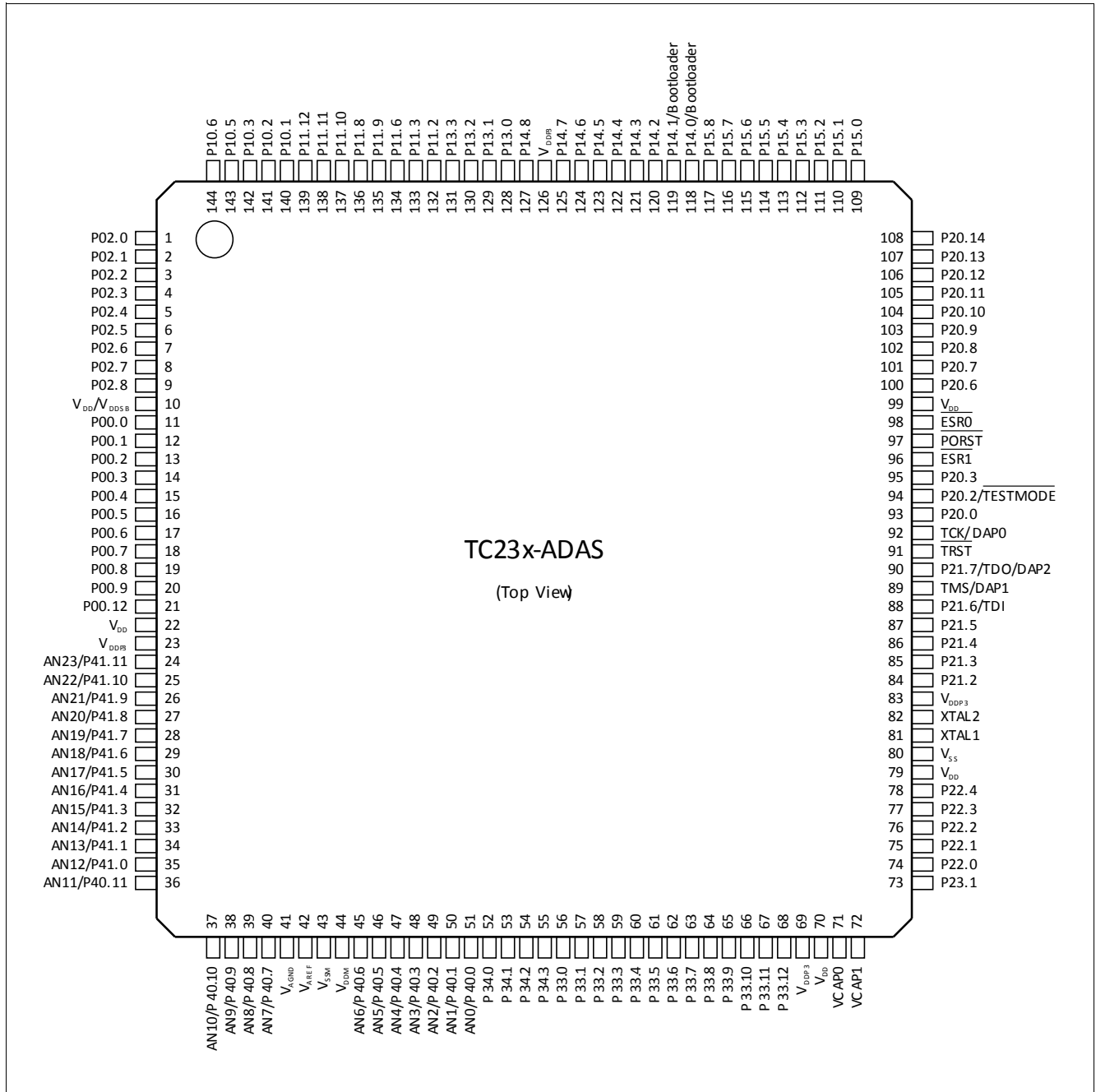

Figure 2-2 TC23x-ADAS Pinout for the package variant PG-TQFP-144-27.

2.2.1 Port Functions and Pinning Tables

2.2.1.1 How to Read the Following Port Function Tables

Some hints for interpreting the following tables.

Column “Ctrl.”:

I = Input (for GPIO port Lines with IOCR bit field Selection PCx = 0XXX_B)

AI = Analog input

O = Output

O0 = Output with IOCR bit field selection PCx = 1X000_B

O1 = Output with IOCR bit field selection PCx = 1X001_B (ALT1)

O2 = Output with IOCR bit field selection PCx = 1X010_B (ALT2)

O3 = Output with IOCR bit field selection PCx = 1X011_B (ALT3)

O4 = Output with IOCR bit field selection PCx = 1X100_B (ALT4)

O5 = Output with IOCR bit field selection PCx = 1X101_B (ALT5)

O6 = Output with IOCR bit field selection PCx = 1X110_B (ALT6)

O7 = Output with IOCR bit field selection PCx = 1X111_B (ALT7)

Table 2-20 Example Port Table

Pin	Symbol	Ctrl.	Buffer Type	Function
10	Pxx.y	I	A1/HighZ/ VDDP3	General-purpose input
	TIMm_n			GTM_TIN
	TOMa_b	O1		GTM_TOUT
	TOMc_d			GTM_TOUT
	IOM_REFv_w			IOM reference input

To each input several functions can be connected. The peripherals' configuration defines if this input is used.

The port module (see corresponding chapter) decides which of the 8 output signals O0 to O7 drives the pad.

Some Ox rows list more than one function, e.g. several GTM_TOUT and IOM reference inputs. The GTM module (see corresponding chapter) has its own sub-multiplexer structure that defines which of the GTM sub-units drives this signal. Additionally the IOM modules “listens” on these output signals (see IOM chapter).

Column “Type”:

IN = Input only

A1 = Pad class A1 (3.3V)

A1+ = Pad class A1+ (3.3V)

S = ADC with digital input. Pad class D for analog input “AI”, pad class S for digital input “I”.

PU = with pull-up device connected during reset ($\overline{\text{PORST}} = 0$)

PD = with pull-down device connected during reset ($\overline{\text{PORST}} = 0$)

High-Z = High-Z during reset ($\overline{\text{PORST}} = 0$)

V_x = Supply (the Exposed Pad is also considered as VSS and shall be connected to ground)

2.2.1.2 Tables

Port function and pinning tables.

Table 2-21 Port 00 Functions

Pin	Symbol	Ctrl.	Buffer Type	Function
11	P00.0	I	A1 / HighZ / VDDP3	General-purpose input
	TIM0_0			GTM_TIN
	CCU61_CTRAPA			CCU61 input
	CCU60_T12HRE			CCU60 input
	ETH0_MDIOA			Ethernet input
	P00.0	O0		General-purpose output
	TOM0_8	O1		GTM_TOUT
	TOM1_0			GTM_TOUT
	TOM0_4			GTM_TOUT (= DTM1_OUT4)
	TOM1_4			GTM_TOUT (= DTM5_OUT4)
	IOM_REF0_9			IOM reference input
	ASCLIN0_SCLK	O2		ASCLIN0 output (aka: ASCLK0)
	ASCLIN0_TX	O3		ASCLIN0 output (aka: ATX0)
	IOM_MON2_12	O4		IOM monitor input
	IOM_REF2_12			IOM reference input
	—		Reserved	
	CAN1_TXD	O5	CAN node 1 output (aka: TXDCAN1)	
	IOM_MON2_6	O6	IOM monitor input	
	IOM_REF2_6		IOM reference input	
	—	O7	Reserved	
	CCU60_COUT63	O7	CCU60 output	
	IOM_MON1_6		IOM monitor input	
	IOM_REF1_0		IOM reference input	
ETH0_MDIO	O	Ethernet output		

Table 2-21 Port 00 Functions (cont'd)

Pin	Symbol	Ctrl.	Buffer Type	Function
12	P00.1	I	A1 / HighZ / VDDP3	General-purpose input
	TIM0_1			GTM_TIN
	ASCLIN0_RXC			ASCLIN0 input (aka: ARX0C)
	CAN1_RXDD			CAN node 1 input (aka: RXDCAN1D)
	SENT_SENT0B			SENT input
	CCU60_CC60INB			CCU60 input
	CCU61_CC60INA			CCU61 input
	P00.1	O0	General-purpose output	
	TOM0_9	O1	GTM_TOUT	
	TOM1_1		GTM_TOUT	
	TOM0_4N		GTM_TOUT (= DTM1_OUT4_N)	
	TOM1_4N		GTM_TOUT (= DTM5_OUT4_N)	
	IOM_REF0_10		IOM reference input	
	ASCLIN0_TX	O2	ASCLIN0 output (aka: ATX0)	
	IOM_MON2_12	IOM monitor input		
	IOM_REF2_12	IOM reference input		
	—	O3	Reserved	
	—	O4	Reserved	
	—	O5	Reserved	
	SENT_SPC0	O6	SENT output	
	CCU61_CC60	O7	CCU61 output	
	IOM_MON1_8		IOM monitor input	
	IOM_REF1_13		IOM reference input	

Package and Pinning Definitions PG-TQFP-144-27 Package Variant Pin

Table 2-21 Port 00 Functions (cont'd)

Pin	Symbol	Ctrl.	Buffer Type	Function	
13	P00.2	I	A1 / HighZ / VDDP3	General-purpose input	
	TIM0_1			GTM_TIN	
	SENT_SENT1B			SENT input	
	P00.2	O0		General-purpose output	
	TOM0_9	O1		GTM_TOUT	
	TOM1_1			GTM_TOUT	
	TOM0_5			GTM_TOUT (= DTM1_OUT5)	
	TOM1_5			GTM_TOUT (= DTM5_OUT5)	
	IOM_REF0_11			IOM reference input	
	ASCLIN0_SCLK			O2	ASCLIN0 output (aka: ASCLK0)
	—			O3	Reserved
	—	O4		Reserved	
	CAN12_TXD	O5		CAN1 node 2 output (aka: TXDCAN12)	
	—	O6		Reserved	
	CCU61_COUT60	O7		CCU61 output	
	IOM_MON1_11			IOM monitor input	
IOM_REF1_10	IOM reference input				
14	P00.3	I	A1 / HighZ / VDDP3	General-purpose input	
	SENT_SENT2B			SENT input	
	CCU60_CC61INB			CCU60 input	
	CCU61_CC61INA			CCU61 input	
	CAN11_RXDA			CAN1 node 1 input (aka: RXDCAN11A)	
	CAN12_RXDA			CAN1 node 2 input (aka: RXDCAN12A)	
	P00.3	O0		General-purpose output	
	TOM0_10	O1		GTM_TOUT	
	TOM1_2			GTM_TOUT	
	TOM0_5N			GTM_TOUT (= DTM1_OUT5_N)	
	TOM1_5N			GTM_TOUT (= DTM5_OUT5_N)	
	IOM_REF0_12			IOM reference input	
	—	O2		Reserved	
	—	O3		Reserved	
	—	O4		Reserved	
	—	O5		Reserved	
SENT_SPC2	O6	SENT output			
CCU61_CC61	O7	CCU61 output			
IOM_MON1_9		IOM monitor input			
IOM_REF1_12		IOM reference input			

Package and Pinning Definitions PG-TQFP-144-27 Package Variant Pin

Table 2-21 Port 00 Functions (cont'd)

Pin	Symbol	Ctrl.	Buffer Type	Function	
15	P00.4	I	A1 / HighZ / VDDP3	General-purpose input	
	SCU_REQ7			SCU input	
	SENT_SENT3B			SENT input	
	P00.4	O0		General-purpose output	
	TOM0_11	O1		GTM_TOUT	
	TOM1_3			GTM_TOUT	
	TOM0_6			GTM_TOUT (= DTM1_OUT6)	
	TOM1_6			GTM_TOUT (= DTM5_OUT6)	
	IOM_REF0_13			IOM reference input	
	—			O2	Reserved
	CAN10_TXD			O3	CAN1 node 0 output (aka: TXDCAN10)
	—	O4		Reserved	
	VADC_G1BFL0	O5		VADC output	
	SENT_SPC3	O6		SENT output	
	CCU61_COUT61	O7		CCU61 output	
	IOM_MON1_12			IOM monitor input	
IOM_REF1_9	IOM reference input				
16	P00.5	I	A1 / HighZ / VDDP3	General-purpose input	
	CCU60_CC62INB			CCU60 input	
	CCU61_CC62INA			CCU61 input	
	CAN10_RXDG			CAN1 node 0 input (aka: RXDCAN10G)	
	P00.5	O0		General-purpose output	
	TOM0_12	O1		GTM_TOUT	
	TOM1_4			GTM_TOUT (= DTM5_OUT4)	
	TOM0_6N			GTM_TOUT (= DTM1_OUT6_N)	
	TOM1_6N			GTM_TOUT (= DTM5_OUT6_N)	
	IOM_REF0_14			IOM reference input	
	—			O2	Reserved
	—			O3	Reserved
	—	O4		Reserved	
	VADC_G1BFL1	O5		VADC output	
	—	O6		Reserved	
	CCU61_CC62	O7		CCU61 output	
IOM_MON1_10	IOM monitor input				
IOM_REF1_11	IOM reference input				

Table 2-21 Port 00 Functions (cont'd)

Pin	Symbol	Ctrl.	Buffer Type	Function
17	P00.6	I	A1 / HighZ / VDDP3	General-purpose input
	CAN11_RXDG			CAN1 node 1 input (aka: RXDCAN11G)
	P00.6	O0		General-purpose output
	TOM0_13	O1		GTM_TOUT
	TOM1_5			GTM_TOUT (= DTM5_OUT5)
	TOM0_7			GTM_TOUT (= DTM1_OUT7)
	TOM1_7			GTM_TOUT (= DTM5_OUT7)
	IOM_REF0_15			IOM reference input
	—	O2		Reserved
	VADC_G1BFL2	O3		VADC output
	—	O4		Reserved
	VADC_EMUX10	O5		VADC output
	—	O6		Reserved
	CCU61_COUT62	O7		CCU61 output
	IOM_MON1_13			IOM monitor input
IOM_REF1_8	IOM reference input			
18	P00.7	I	A1 / HighZ / VDDP3	General-purpose input
	CCU61_CC60INC			CCU61 input
	CCU61_CCPOS0A			CCU61 input
	CCU60_T12HRB			CCU60 input
	GPT120_T2INA			GPT120 input
	P00.7	O0		General-purpose output
	TOM0_14	O1		GTM_TOUT
	TOM1_6			GTM_TOUT (= DTM5_OUT6)
	TOM0_7N			GTM_TOUT (= DTM1_OUT7_N)
	TOM1_7N			GTM_TOUT (= DTM5_OUT7_N)
	CAN11_TXD	O2		CAN1 node 1 output (aka: TXDCAN11)
	VADC_G1BFL3	O3		VADC output
	—	O4		Reserved
	VADC_EMUX11	O5		VADC output
	—	O6		Reserved
CCU61_CC60	O7	CCU61 output		
IOM_MON1_8		IOM monitor input		
IOM_REF1_13		IOM reference input		

Package and Pinning Definitions PG-TQFP-144-27 Package Variant Pin

Table 2-21 Port 00 Functions (cont'd)

Pin	Symbol	Ctrl.	Buffer Type	Function
19	P00.8	I	A1 / HighZ / VDDP3	General-purpose input
	CCU61_CC61INC			CCU61 input
	CCU61_CCPOS1A			CCU61 input
	CCU60_T13HRB			CCU60 input
	GPT120_T2EUDA			GPT120 input
	CAN12_RXDG			CAN1 node 2 input (aka: RXDCAN12G)
	P00.8	O0	A1 / HighZ / VDDP3	General-purpose output
	TOM0_15	O1		GTM_TOUT
	TOM1_7	O2		GTM_TOUT (= DTM5_OUT7)
	QSPI3_SLSO6			QSPI3 output (aka: SLSO36)
	—	O3		Reserved
	—	O4		Reserved
	VADC_EMUX12	O5		VADC output
	—	O6		Reserved
	CCU61_CC61	O7		CCU61 output
	IOM_MON1_9			IOM monitor input
	IOM_REF1_12		IOM reference input	
20	P00.9	I	A1 / HighZ / VDDP3	General-purpose input
	TIM0_0			GTM_TIN
	CCU61_CC62INC			CCU61 input
	CCU61_CCPOS2A			CCU61 input
	CCU60_T13HRC			CCU60 input
	CCU60_T12HRC			CCU60 input
	GPT120_T4EUDA	GPT120 input		
	P00.9	O0	A1 / HighZ / VDDP3	General-purpose output
	TOM0_0	O1		GTM_TOUT
	TOM1_0	O2		GTM_TOUT
	QSPI3_SLSO7			QSPI3 output (aka: SLSO37)
	ASCLIN0_RTS	O3		ASCLIN0 output (aka: ARTS0)
	—	O4		Reserved
	CAN12_TXD	O5		CAN1 node 2 output (aka: TXDCAN12)
	—	O6		Reserved
	CCU61_CC62	O7		CCU61 output
	IOM_MON1_10			IOM monitor input
IOM_REF1_11	IOM reference input			

Table 2-21 Port 00 Functions (cont'd)

Pin	Symbol	Ctrl.	Buffer Type	Function
21	P00.12	I	A1 / HighZ / VDDP3	General-purpose input
	TIM0_3			GTM_TIN
	ASCLIN0_CTSA			ASCLIN0 input (aka: ACTS0A)
	P00.12	O0		General-purpose output
	TOM0_3	O1		GTM_TOUT
	TOM1_3			GTM_TOUT
	—	O2		Reserved
	—	O3		Reserved
	—	O4		Reserved
	—	O5		Reserved
	—	O6		Reserved
	CCU61_COUT63	O7		CCU61 output
	IOM_MON1_7			IOM monitor input
	IOM_REF1_7			IOM reference input

Table 2-22 Port 02 Functions

Pin	Symbol	Ctrl.	Buffer Type	Function
1	P02.0	I	A1+ / HighZ / VDDP3	General-purpose input
	TIM0_0			GTM_TIN
	SCU_REQ6			SCU input
	CCU60_CC60INA			CCU60 input
	CCU61_CC60INB			CCU61 input
	P02.0	O0		General-purpose output
	TOM0_8	O1		GTM_TOUT
	TOM1_8			GTM_TOUT
	TOM0_4			GTM_TOUT (= DTM1_OUT4)
	TOM1_4			GTM_TOUT (= DTM5_OUT4)
	IOM_REF0_0		IOM reference input	
	—	O2	Reserved	
	QSPI3_SLSO1	O3	QSPI3 output (aka: SLSO31)	
	—	O4	Reserved	
	CAN0_TXD	O5	CAN node 0 output (aka: TXDCAN0)	
	IOM_MON2_5		IOM monitor input	
	IOM_REF2_5		IOM reference input	
	ERAY0_TXDA	O6	ERAY0 output	
	CCU60_CC60	O7	CCU60 output	
	IOM_MON1_2		IOM monitor input	
IOM_REF1_6	IOM reference input			

Table 2-22 Port 02 Functions (cont'd)

Pin	Symbol	Ctrl.	Buffer Type	Function
2	P02.1	I	A1 / HighZ / VDDP3	General-purpose input
	TIM0_1			GTM_TIN
	CAN0_RXDA			CAN node 0 input (aka: RXDCAN0A)
	ERAY0_RXDA2			ERAY0 input
	SCU_REQ14			SCU input
	P02.1	O0		General-purpose output
	TOM0_9	O1		GTM_TOUT
	TOM1_9			GTM_TOUT
	TOM0_4N			GTM_TOUT (= DTM1_OUT4_N)
	TOM1_4N			GTM_TOUT (= DTM5_OUT4_N)
	IOM_REF0_1			IOM reference input
	—	O2		Reserved
	QSPI3_SLSO2	O3		QSPI3 output (aka: SLSO32)
	—	O4		Reserved
	—	O5		Reserved
	—	O6		Reserved
	CCU60_COUT60	O7		CCU60 output
	IOM_MON1_3			IOM monitor input
	IOM_REF1_3			IOM reference input

Table 2-22 Port 02 Functions (cont'd)

Pin	Symbol	Ctrl.	Buffer Type	Function
3	P02.2	I	A1+ / HighZ / VDDP3	General-purpose input
	TIM0_2			GTM_TIN
	CCU60_CC61INA			CCU60 input
	CCU61_CC61INB			CCU61 input
	P02.2	O0		General-purpose output
	TOM0_10	O1		GTM_TOUT
	TOM1_10			GTM_TOUT
	TOM0_5			GTM_TOUT (= DTM1_OUT5)
	TOM1_5			GTM_TOUT (= DTM5_OUT5)
	IOM_REF0_2			IOM reference input
	ASCLIN1_TX	O2	ASCLIN1 output (aka: ATX1)	
	IOM_MON2_13		IOM monitor input	
	IOM_REF2_13		IOM reference input	
	QSPI3_SLSO3	O3	QSPI3 output (aka: SLSO33)	
	—	O4	Reserved	
	CAN2_TXD	O5	CAN node 2 output (aka: TXDCAN2)	
	IOM_MON2_7		IOM monitor input	
	IOM_REF2_7		IOM reference input	
	ERAY0_TXDB	O6	ERAY0 output	
	CCU60_CC61	O7	CCU60 output	
IOM_MON1_1	IOM monitor input			
IOM_REF1_5	IOM reference input			

Table 2-22 Port 02 Functions (cont'd)

Pin	Symbol	Ctrl.	Buffer Type	Function
4	P02.3	I	A1 / HighZ / VDDP3	General-purpose input
	TIM0_3			GTM_TIN
	ASCLIN1_RXG			ASCLIN1 input (aka: ARX1G)
	CAN2_RXDB			CAN node 2 input (aka: RXDCAN2B)
	ERAY0_RXDB2			ERAY0 input
	P02.3	O0		General-purpose output
	TOM0_11	O1		GTM_TOUT
	TOM1_11			GTM_TOUT
	TOM0_5N			GTM_TOUT (= DTM1_OUT5_N)
	TOM1_5N			GTM_TOUT (= DTM5_OUT5_N)
	IOM_REF0_3			IOM reference input
	—	O2		Reserved
	QSPI3_SLSO4	O3		QSPI3 output (aka: SLSO34)
	—	O4		Reserved
	—	O5		Reserved
	—	O6		Reserved
	CCU60_COUT61	O7		CCU60 output
	IOM_MON1_4			IOM monitor input
	IOM_REF1_2			IOM reference input

Table 2-22 Port 02 Functions (cont'd)

Pin	Symbol	Ctrl.	Buffer Type	Function
5	P02.4	I	A1+ / HighZ / VDDP3	General-purpose input
	TIM0_4			GTM_TIN
	QSPI3_SLSIA			QSPI3 input (aka: SLSI3A)
	CAN0_RXDD			CAN node 0 input (aka: RXDCAN0D)
	CCU60_CC62INA			CCU60 input
	CCU61_CC62INB			CCU61 input
	P02.4	O0	A1+ / HighZ / VDDP3	General-purpose output
	TOM0_12	O1		GTM_TOUT
	TOM1_12			GTM_TOUT
	TOM0_6			GTM_TOUT (= DTM1_OUT6)
	TOM1_6			GTM_TOUT (= DTM5_OUT6)
	IOM_REF0_4			IOM reference input
	—			O2
	QSPI3_SLSO0	O3		QSPI3 output (aka: SLSO30)
	—	O4		Reserved
	CAN10_TXD	O5		CAN1 node 0 output (aka: TXDCAN10)
	ERAY0_TXENA	O6		ERAY0 output
	CCU60_CC62	O7		CCU60 output
	IOM_MON1_0			IOM monitor input
	IOM_REF1_4			IOM reference input

Table 2-22 Port 02 Functions (cont'd)

Pin	Symbol	Ctrl.	Buffer Type	Function
6	P02.5	I	A1+ / HighZ / VDDP3	General-purpose input
	TIM0_5			GTM_TIN
	QSPI3_MRSTA			QSPI3 input (aka: MRST3A)
	SENT_SENT3C			SENT input
	P02.5	O0		General-purpose output
	TOM0_13	O1		GTM_TOUT
	TOM1_13			GTM_TOUT
	TOM0_6N			GTM_TOUT (= DTM1_OUT6_N)
	TOM1_6N			GTM_TOUT (= DTM5_OUT6_N)
	IOM_REF0_5	O2		IOM reference input
	CAN0_TXD			CAN node 0 output (aka: TXDCAN0)
	IOM_MON2_5			IOM monitor input
	IOM_REF2_5		IOM reference input	
	QSPI3_MRST	O3	QSPI3 output (aka: MRST3)	
	IOM_MON2_3		IOM monitor input	
	IOM_REF2_3		IOM reference input	
	—	O4	Reserved	
	CAN11_TXD	O5	CAN1 node 1 output (aka: TXDCAN11)	
	ERAY0_TXENB	O6	ERAY0 output	
	CCU60_COUT62	O7	CCU60 output	
IOM_MON1_5	IOM monitor input			
IOM_REF1_1	IOM reference input			

Table 2-22 Port 02 Functions (cont'd)

Pin	Symbol	Ctrl.	Buffer Type	Function
7	P02.6	I	A1 / HighZ / VDDP3	General-purpose input
	TIM0_6			GTM_TIN
	QSPI3_MTSRA			QSPI3 input (aka: MTSR3A)
	SENT_SENT2C			SENT input
	CCU60_CC60INC			CCU60 input
	CCU60_CCPOS0A			CCU60 input
	CCU61_T12HRB			CCU61 input
	GPT120_T3INA			GPT120 input
	CAN10_RXDF			CAN1 node 0 input (aka: RXDCAN10F)
	P02.6			O0
	TOM0_14	O1	GTM_TOUT	
	TOM1_14		GTM_TOUT	
	TOM0_7		GTM_TOUT (= DTM1_OUT7)	
	TOM1_7		GTM_TOUT (= DTM5_OUT7)	
	IOM_REF0_6		IOM reference input	
	—		O2	Reserved
	QSPI3_MTSR	O3	QSPI3 output (aka: MTSR3)	
	—	O4	Reserved	
	VADC_EMUX00	O5	VADC output	
	—	O6	Reserved	
CCU60_CC60	O7	CCU60 output		
IOM_MON1_2		IOM monitor input		
IOM_REF1_6		IOM reference input		

Table 2-22 Port 02 Functions (cont'd)

Pin	Symbol	Ctrl.	Buffer Type	Function
8	P02.7	I	A1 / HighZ / VDDP3	General-purpose input
	TIM0_7			GTM_TIN
	QSPI3_SCLKA			QSPI3 input (aka: SCLK3A)
	SENT_SENT1C			SENT input
	CCU60_CC61INC			CCU60 input
	CCU60_CCPOS1A			CCU60 input
	CCU61_T13HRB			CCU61 input
	GPT120_T3EUDA			GPT120 input
	CAN11_RXDF			CAN1 node 1 input (aka: RXDCAN11F)
	PMU_FDEST			PMU input
	P02.7	O0	General-purpose output	
	TOM0_15	O1	GTM_TOUT	
	TOM1_15		GTM_TOUT	
	TOM0_7N		GTM_TOUT (= DTM1_OUT7_N)	
	TOM1_7N		GTM_TOUT (= DTM5_OUT7_N)	
	IOM_REF0_7		IOM reference input	
	—		O2	Reserved
	QSPI3_SCLK	O3	QSPI3 output (aka: SCLK3)	
	—	O4	Reserved	
	VADC_EMUX01	O5	VADC output	
	SENT_SPC1	O6	SENT output	
	CCU60_CC61	O7	CCU60 output	
	IOM_MON1_1		IOM monitor input	
	IOM_REF1_5		IOM reference input	

Table 2-22 Port 02 Functions (cont'd)

Pin	Symbol	Ctrl.	Buffer Type	Function
9	P02.8	I	A1 / HighZ / VDDP3	General-purpose input
	TIM0_0			GTM_TIN
	SENT_SENT0C			SENT input
	CCU60_CC62INC			CCU60 input
	CCU60_CCPOS2A			CCU60 input
	CCU61_T12HRC			CCU61 input
	CCU61_T13HRC			CCU61 input
	GPT120_T4INA			GPT120 input
	P02.8	O0	General-purpose output	
	TOM0_8	O1	GTM_TOUT	
	TOM1_0		GTM_TOUT	
	TOM0_4N		GTM_TOUT (= DTM1_OUT4_N)	
	TOM1_4N		GTM_TOUT (= DTM5_OUT4_N)	
	IOM_REF0_8		IOM reference input	
	QSPI3_SLSO5		O2	QSPI3 output (aka: SLSO35)
	—	O3	Reserved	
	—	O4	Reserved	
	VADC_EMUX02	O5	VADC output	
	ETH0_MDC	O6	Ethernet output	
	CCU60_CC62	O7	CCU60 output	
IOM_MON1_0	IOM monitor input			
IOM_REF1_4	IOM reference input			

Table 2-23 Port 10 Functions

Pin	Symbol	Ctrl.	Buffer Type	Function	
140	P10.1	I	A1+ / HighZ / VDDP3	General-purpose input	
	TIM0_1			GTM_TIN	
	QSPI1_MRSTA			QSPI1 input (aka: MRST1A)	
	GPT120_T5EUDB			GPT120 input	
	ETH0_CRSC			Ethernet input	
	P10.1	O0		General-purpose output	
	TOM0_1	O1		GTM_TOUT	
	TOM1_9			GTM_TOUT	
	QSPI1_MTSR	O2		QSPI1 output (aka: MTSR1)	
	QSPI1_MRST	O3		QSPI1 output (aka: MRST1)	
	IOM_MON2_1			IOM monitor input	
	IOM_REF2_1			IOM reference input	
	—	O4		Reserved	
	—	O5		Reserved	
—	O6	Reserved			
—	O7	Reserved			
141	P10.2	I	A1+ / HighZ / VDDP3	General-purpose input	
	TIM0_2			GTM_TIN	
	QSPI1_SCLKA			QSPI1 input (aka: SCLK1A)	
	CAN2_RXDE			CAN node 2 input (aka: RXDCAN2E)	
	SCU_REQ2			SCU input	
	GPT120_T6INB			GPT120 input	
	ETH0_COLB			Ethernet input	
	P10.2			O0	General-purpose output
	TOM0_2			O1	GTM_TOUT
	TOM1_10				GTM_TOUT
	IOM_MON2_9				IOM monitor input
	—			O2	Reserved
	QSPI1_SCLK			O3	QSPI1 output (aka: SCLK1)
	—			O4	Reserved
—	O5	Reserved			
—	O6	Reserved			
—	O7	Reserved			

Table 2-23 Port 10 Functions (cont'd)

Pin	Symbol	Ctrl.	Buffer Type	Function
142	P10.3	I	A1+ / HighZ / VDDP3	General-purpose input
	TIM0_3			GTM_TIN
	QSPI1_MTSRA			QSPI1 input (aka: MTSR1A)
	SCU_REQ3			SCU input
	GPT120_T5INB			GPT120 input
	ETH0_RXERC			Ethernet input
	P10.3	O0		General-purpose output
	TOM0_3	O1		GTM_TOUT
	TOM1_11			GTM_TOUT
	IOM_MON2_10			IOM monitor input
	—	O2		Reserved
	QSPI1_MTSR	O3		QSPI1 output (aka: MTSR1)
	—	O4		Reserved
	—	O5		Reserved
	CAN2_TXD	O6		CAN node 2 output (aka: TXDCAN2)
	IOM_MON2_7			IOM monitor input
	IOM_REF2_7			IOM reference input
	—	O7		Reserved
143	P10.5	I	A1 / HighZ / VDDP3	General-purpose input
	TIM0_2			GTM_TIN
	SCU_HWCFG4			SCU input
	CAN10_RXDA			CAN1 node 0 input (aka: RXDCAN10A)
	ETH0_RXD3B			Ethernet input
	P10.5	O0		General-purpose output
	TOM0_2	O1		GTM_TOUT
	TOM1_10			GTM_TOUT
	IOM_REF2_9			IOM reference input
	—	O2		Reserved
	QSPI3_SLSO8	O3		QSPI3 output (aka: SLSO38)
	QSPI1_SLSO9	O4		QSPI1 output (aka: SLSO19)
	GPT120_T6OUT	O5		GPT120 output
	—	O6		Reserved
	—	O7		Reserved

Package and Pinning Definitions PG-TQFP-144-27 Package Variant Pin

Table 2-23 Port 10 Functions (cont'd)

Pin	Symbol	Ctrl.	Buffer Type	Function
144	P10.6	I	A1 / HighZ / VDDP3	General-purpose input
	TIM0_3			GTM_TIN
	QSPI3_MTSRB			QSPI3 input (aka: MTSR3B)
	SCU_HWCFG5			SCU input
	P10.6	O0		General-purpose output
	TOM0_3	O1		GTM_TOUT
	TOM1_11			GTM_TOUT
	IOM_REF2_10	O2		IOM reference input
	—			Reserved
	QSPI3_MTSR	O3		QSPI3 output (aka: MTSR3)
	GPT120_T3OUT	O4		GPT120 output
	CAN10_TXD	O5		CAN1 node 0 output (aka: TXDCAN10)
	QSPI1_MRST	O6		QSPI1 output (aka: MRST1)
	IOM_MON2_1			IOM monitor input
	IOM_REF2_1			IOM reference input
	—	O7		Reserved

Table 2-24 Port 11 Functions

Pin	Symbol	Ctrl.	Buffer Type	Function
132	P11.2	I	A1+ / HighZ / VDDP3	General-purpose input
	P11.2	O0		General-purpose output
	TOM0_8	O1		GTM_TOUT
	TOM1_1			GTM_TOUT
	TOM0_4N			GTM_TOUT (= DTM1_OUT4_N)
	TOM1_4N			GTM_TOUT (= DTM5_OUT4_N)
	—	O2		Reserved
	QSPI0_SLSO5	O3		QSPI0 output (aka: SLSO05)
	QSPI1_SLSO5	O4		QSPI1 output (aka: SLSO15)
	CCU61_COUT63	O5		CCU61 output
	IOM_MON1_7			IOM monitor input
	IOM_REF1_7			IOM reference input
	ETH0_TXD1	O6		Ethernet output
	CCU60_COUT63	O7		CCU60 output
	IOM_MON1_6			IOM monitor input
	IOM_REF1_0			IOM reference input

Table 2-24 Port 11 Functions (cont'd)

Pin	Symbol	Ctrl.	Buffer Type	Function
133	P11.3	I	A1+ / HighZ / VDDP3	General-purpose input
	QSPI1_MRSTB			QSPI1 input (aka: MRST1B)
	P11.3	O0		General-purpose output
	TOM0_10	O1		GTM_TOUT
	TOM1_2			GTM_TOUT
	TOM0_5			GTM_TOUT (= DTM1_OUT5)
	TOM1_5			GTM_TOUT (= DTM5_OUT5)
	—	O2		Reserved
	QSPI1_MRST	O3		QSPI1 output (aka: MRST1)
	IOM_MON2_1			IOM monitor input
	IOM_REF2_1			IOM reference input
	ERAY0_TXDA	O4		ERAY0 output
	CCU61_COUT62	O5		CCU61 output
	IOM_MON1_13			IOM monitor input
	IOM_REF1_8			IOM reference input
	ETH0_TXD0			O6
	CCU60_COUT62	O7		CCU60 output
	IOM_MON1_5			IOM monitor input
IOM_REF1_1	IOM reference input			
134	P11.6	I	A1+ / HighZ / VDDP3	General-purpose input
	QSPI1_SCLKB			QSPI1 input (aka: SCLK1B)
	P11.6	O0		General-purpose output
	TOM0_11	O1		GTM_TOUT
	TOM1_3			GTM_TOUT
	TOM0_5N			GTM_TOUT (= DTM1_OUT5_N)
	TOM1_5N			GTM_TOUT (= DTM5_OUT5_N)
	ERAY0_TXENB	O2		ERAY0 output
	QSPI1_SCLK	O3		QSPI1 output (aka: SCLK1)
	ERAY0_TXENA	O4		ERAY0 output
	CCU61_COUT61	O5		CCU61 output
	IOM_MON1_12			IOM monitor input
	IOM_REF1_9			IOM reference input
	ETH0_TXEN			O6
	CCU60_COUT61	O7		CCU60 output
	IOM_MON1_4			IOM monitor input
	IOM_REF1_2			IOM reference input

Package and Pinning Definitions PG-TQFP-144-27 Package Variant Pin

Table 2-24 Port 11 Functions (cont'd)

Pin	Symbol	Ctrl.	Buffer Type	Function
136	P11.8	I	A1 / HighZ / VDDP3	General-purpose input
	QSPI1_MTSRC			QSPI1 input (aka: MTSR1C)
	ETH0_RXD2A			Ethernet input
	P11.8	O0		General-purpose output
	TOM0_4	O1		GTM_TOUT (= DTM1_OUT4)
	TOM1_4			GTM_TOUT (= DTM5_OUT4)
	—	O2		Reserved
	QSPI1_SLSO10	O3		QSPI1 output (aka: SLSO110)
	QSPI1_MTSR	O4		QSPI1 output (aka: MTSR1)
	—	O5		Reserved
	—	O6		Reserved
	—	O7		Reserved
135	P11.9	I	A1+ / HighZ / VDDP3	General-purpose input
	QSPI1_MTSRB			QSPI1 input (aka: MTSR1B)
	ERAY0_RXDA1			ERAY0 input
	ETH0_RXD1A			Ethernet input
	P11.9	O0		General-purpose output
	TOM0_12	O1		GTM_TOUT
	TOM1_4			GTM_TOUT (= DTM5_OUT4)
	TOM0_6			GTM_TOUT (= DTM1_OUT6)
	TOM1_6	O2		GTM_TOUT (= DTM5_OUT6)
	—			Reserved
	QSPI1_MTSR	O3		QSPI1 output (aka: MTSR1)
	—	O4		Reserved
	CCU61_COUT60	O5		CCU61 output
	IOM_MON1_11			IOM monitor input
	IOM_REF1_10			IOM reference input
	—	O6		Reserved
	CCU60_COUT60	O7		CCU60 output
	IOM_MON1_3			IOM monitor input
IOM_REF1_3	IOM reference input			

Table 2-24 Port 11 Functions (cont'd)

Pin	Symbol	Ctrl.	Buffer Type	Function
137	P11.10	I	A1+ / HighZ / VDDP3	General-purpose input
	ASCLIN1_RXE			ASCLIN1 input (aka: ARX1E)
	ERAY0_RXDB1			ERAY0 input
	SCU_REQ12			SCU input
	CAN12_RXDD			CAN1 node 2 input (aka: RXDCAN12D)
	ETH0_RXD0A			Ethernet input
	P11.10	O0	General-purpose output	
	TOM0_13	O1	GTM_TOUT	
	TOM1_5		GTM_TOUT (= DTM5_OUT5)	
	TOM0_6N		GTM_TOUT (= DTM1_OUT6_N)	
	TOM1_6N		GTM_TOUT (= DTM5_OUT6_N)	
	—	O2	Reserved	
	QSPI0_SLSO3	O3	QSPI0 output (aka: SLSO03)	
	QSPI1_SLSO3	O4	QSPI1 output (aka: SLSO13)	
	CCU61_CC62	O5	CCU61 output	
	IOM_MON1_10		IOM monitor input	
	IOM_REF1_11		IOM reference input	
	—	O6	Reserved	
	CCU60_CC62	O7	CCU60 output	
	IOM_MON1_0		IOM monitor input	
IOM_REF1_4	IOM reference input			

Table 2-24 Port 11 Functions (cont'd)

Pin	Symbol	Ctrl.	Buffer Type	Function
138	P11.11	I	A1+ / HighZ / VDDP3	General-purpose input
	ETH0_RXDVA			Ethernet input
	ETH0_CRSDVA			Ethernet input
	ETH0_CRSB			Ethernet input
	P11.11	O0		General-purpose output
	TOM0_14	O1		GTM_TOUT
	TOM1_6			GTM_TOUT (= DTM5_OUT6)
	TOM0_7N			GTM_TOUT (= DTM1_OUT7_N)
	TOM1_7N			GTM_TOUT (= DTM5_OUT7_N)
	—	O2		Reserved
	QSPI0_SLSO4	O3		QSPI0 output (aka: SLSO04)
	QSPI1_SLSO4	O4		QSPI1 output (aka: SLSO14)
	CCU61_CC61	O5		CCU61 output
	IOM_MON1_9			IOM monitor input
	IOM_REF1_12			IOM reference input
	ERAY0_TXENB	O6		ERAY0 output
	CCU60_CC61	O7		CCU60 output
	IOM_MON1_1			IOM monitor input
	IOM_REF1_5			IOM reference input

Table 2-24 Port 11 Functions (cont'd)

Pin	Symbol	Ctrl.	Buffer Type	Function
139	P11.12	I	A1+ / HighZ / VDDP3	General-purpose input
	ETH0_REFCLK			Ethernet input
	ETH0_RXCLKA			Ethernet input
	ETH0_TXCLKB			Ethernet input
	P11.12	O0		General-purpose output
	TOM0_15	O1		GTM_TOUT
	TOM1_7		GTM_TOUT (= DTM5_OUT7)	
	TOM0_7		GTM_TOUT (= DTM1_OUT7)	
	TOM1_7		GTM_TOUT (= DTM5_OUT7)	
	ASCLIN1_TX	O2		ASCLIN1 output (aka: ATX1)
	IOM_MON2_13		IOM monitor input	
	IOM_REF2_13		IOM reference input	
	GTM_CLK2	O3		GTM output
	ERAY0_TXDB	O4		ERAY0 output
	CCU61_CC60	O5		CCU61 output
	IOM_MON1_8		IOM monitor input	
	IOM_REF1_13		IOM reference input	
	SCU_EXTCLK1	O6		SCU output
	CCU60_CC60	O7		CCU60 output
	IOM_MON1_2		IOM monitor input	
IOM_REF1_6	IOM reference input			

Table 2-25 Port 13 Functions

Pin	Symbol	Ctrl.	Buffer Type	Function
128	P13.0	I	A1 / HighZ / VDDP3	General-purpose input
	CCU60_CTRAPA			CCU60 input
	GPT120_T6EUDB			GPT120 input
	P13.0	O0		General-purpose output
	TOM0_5	O1		GTM_TOUT (= DTM1_OUT5)
	TOM1_5			GTM_TOUT (= DTM5_OUT5)
	TOM0_6N			GTM_TOUT (= DTM1_OUT6_N)
	TOM1_6N			GTM_TOUT (= DTM5_OUT6_N)
	—	O2		Reserved
	QSPI2_SCLK	O3		QSPI2 output (aka: SCLK2)
	—	O4		Reserved
	—	O5		Reserved
	ETH0_TXER	O6		Ethernet output
	CAN10_TXD	O7		CAN1 node 0 output (aka: TXDCAN10)
129	P13.1	I	A1 / HighZ / VDDP3	General-purpose input
	CCU60_CCPOS0C			CCU60 input
	GPT120_T3INB			GPT120 input
	CAN10_RXDB			CAN1 node 0 input (aka: RXDCAN10B)
	ETH0_TXCLKC			Ethernet input
	P13.1	O0		General-purpose output
	TOM0_6	O1		GTM_TOUT (= DTM1_OUT6)
	TOM1_6			GTM_TOUT (= DTM5_OUT6)
	TOM0_7			GTM_TOUT (= DTM1_OUT7)
	TOM1_7			GTM_TOUT (= DTM5_OUT7)
	—	O2		Reserved
	—	O3		Reserved
	—	O4		Reserved
	—	O5		Reserved
	—	O6		Reserved
	—	O7		Reserved

Table 2-25 Port 13 Functions (cont'd)

Pin	Symbol	Ctrl.	Buffer Type	Function
130	P13.2	I	A1+ / HighZ / VDDP3	General-purpose input
	CCU60_CCPOS1C			CCU60 input
	GPT120_T3EUDB			GPT120 input
	GPT120_CAPINA			GPT120 input
	P13.2	O0		General-purpose output
	TOM0_7	O1		GTM_TOUT (= DTM1_OUT7)
	TOM1_7			GTM_TOUT (= DTM5_OUT7)
	TOM0_7N			GTM_TOUT (= DTM1_OUT7_N)
	TOM1_7N			GTM_TOUT (= DTM5_OUT7_N)
	CAN11_TXD	O2		CAN1 node 1 output (aka: TXDCAN11)
	—	O3		Reserved
	—	O4		Reserved
	—	O5		Reserved
	ETH0_TXD3	O6		Ethernet output
—	O7	Reserved		
131	P13.3	I	A1+ / HighZ / VDDP3	General-purpose input
	CCU60_CCPOS2C			CCU60 input
	GPT120_T4INB			GPT120 input
	CAN11_RXDB			CAN1 node 1 input (aka: RXDCAN11B)
	P13.3	O0		General-purpose output
	TOM0_8	O1		GTM_TOUT
	TOM1_0			GTM_TOUT
	TOM0_4			GTM_TOUT (= DTM1_OUT4)
	TOM1_4			GTM_TOUT (= DTM5_OUT4)
	—	O2		Reserved
	QSPI2_MTSR	O3		QSPI2 output (aka: MTSR2)
	—	O4		Reserved
	—	O5		Reserved
	ETH0_TXD2	O6		Ethernet output
—	O7	Reserved		

Table 2-26 Port 14 Functions

Pin	Symbol	Ctrl.	Buffer Type	Function
118	P14.0	I	A1+ / HighZ / VDDP3	General-purpose input
	TIM0_3			GTM_TIN
	P14.0	O0		General-purpose output
	TOM0_3	O1		GTM_TOUT
	TOM1_3			GTM_TOUT
	TOM0_6			GTM_TOUT (= DTM1_OUT6)
	TOM1_6			GTM_TOUT (= DTM5_OUT6)
	ASCLIN0_TX	O2		ASCLIN0 output (aka: ATX0)
	IOM_MON2_12			IOM monitor input
	IOM_REF2_12			IOM reference input
	ERAY0_TXDA	O3		ERAY0 output
	ERAY0_TXDB	O4		ERAY0 output
	CAN1_TXD	O5		CAN node 1 output (aka: TXDCAN1)
	IOM_MON2_6			IOM monitor input
	IOM_REF2_6			IOM reference input
	ASCLIN0_SCLK	O6		ASCLIN0 output (aka: ASCLK0)
	CCU60_COUT62	O7		CCU60 output
	IOM_MON1_5			IOM monitor input
IOM_REF1_1		IOM reference input		

Table 2-26 Port 14 Functions (cont'd)

Pin	Symbol	Ctrl.	Buffer Type	Function
119	P14.1	I	A1+ / HighZ / VDDP3	General-purpose input
	TIM0_4			GTM_TIN
	ASCLIN0_RXA			ASCLIN0 input (aka: ARX0A)
	CAN1_RXDB			CAN node 1 input (aka: RXDCAN1B)
	ERAY0_RXDA3			ERAY0 input
	SCU_REQ15			SCU input
	ERAY0_RXDB3			ERAY0 input
	SCU_EVRWUPA	AI		SCU input
	P14.1	O0	General-purpose output	
	TOM0_4	O1	GTM_TOUT (= DTM1_OUT4)	
	TOM1_4		GTM_TOUT (= DTM5_OUT4)	
	TOM0_7		GTM_TOUT (= DTM1_OUT7)	
	TOM1_7		GTM_TOUT (= DTM5_OUT7)	
	IOM_REF1_14		IOM reference input	
	ASCLIN0_TX	O2	ASCLIN0 output (aka: ATX0)	
	IOM_MON2_12		IOM monitor input	
	IOM_REF2_12		IOM reference input	
	—	O3	Reserved	
	—	O4	Reserved	
	—	O5	Reserved	
	—	O6	Reserved	
	CCU60_COUT63	O7	CCU60 output	
	IOM_MON1_6		IOM monitor input	
IOM_REF1_0	IOM reference input			

Table 2-26 Port 14 Functions (cont'd)

Pin	Symbol	Ctrl.	Buffer Type	Function
120	P14.2	I	A1 / PU / VDDP3	General-purpose input
	TIM0_5			GTM_TIN
	SCU_HWCFG2_EVR13			SCU input
	P14.2	O0		General-purpose output
	TOM0_5	O1		GTM_TOUT (= DTM1_OUT5)
	TOM1_5			GTM_TOUT (= DTM5_OUT5)
	TOM0_6N			GTM_TOUT (= DTM1_OUT6_N)
	TOM1_6N			GTM_TOUT (= DTM5_OUT6_N)
	IOM_REF1_15			IOM reference input
	—	O2		Reserved
	QSPI2_SLSO1	O3		QSPI2 output (aka: SLSO21)
	—	O4		Reserved
	—	O5		Reserved
	—	O6		Reserved
—	O7	Reserved		
121	P14.3	I	A1 / PU / VDDP3	General-purpose input
	TIM0_6			GTM_TIN
	SCU_REQ10			SCU input
	SCU_HWCFG3_BMI			SCU input
	P14.3	O0		General-purpose output
	TOM0_6	O1		GTM_TOUT (= DTM1_OUT6)
	TOM1_6			GTM_TOUT (= DTM5_OUT6)
	IOM_REF2_4			IOM reference input
	—	O2		Reserved
	QSPI2_SLSO3	O3		QSPI2 output (aka: SLSO23)
	ASCLIN1_SLSO	O4		ASCLIN1 output (aka: ASLSO1)
	—	O5		Reserved
	—	O6		Reserved
	—	O7		Reserved

Table 2-26 Port 14 Functions (cont'd)

Pin	Symbol	Ctrl.	Buffer Type	Function
122	P14.4	I	A1+ / HighZ / VDDP3	General-purpose input
	TIM0_7			GTM_TIN
	P14.4	O0		General-purpose output
	TOM0_7	O1		GTM_TOUT (= DTM1_OUT7)
	TOM1_7			GTM_TOUT (= DTM5_OUT7)
	TOM0_7N			GTM_TOUT (= DTM1_OUT7_N)
	TOM1_7N			GTM_TOUT (= DTM5_OUT7_N)
	IOM_REF2_8			IOM reference input
	—			O2
	—	O3		Reserved
	—	O4		Reserved
	—	O5		Reserved
	—	O6		Reserved
	—	O7		Reserved
123	P14.5	I	A1+ / HighZ / VDDP3	General-purpose input
	TIM0_0			GTM_TIN
	P14.5	O0		General-purpose output
	TOM0_0	O1		GTM_TOUT
	TOM1_0			GTM_TOUT
	IOM_REF2_11			IOM reference input
	—	O2		Reserved
	—	O3		Reserved
	—	O4		Reserved
	—	O5		Reserved
	ERAY0_TXDB	O6		ERAY0 output
	—	O7		Reserved

Table 2-26 Port 14 Functions (cont'd)

Pin	Symbol	Ctrl.	Buffer Type	Function
124	P14.6	I	A1+ / PU / VDDP3	General-purpose input
	TIM0_1			GTM_TIN
	SCU_HWCFG0_DCLDO			SCU input
	QSPIO_MRSTD			QSPIO input (aka: MRST0D)
	P14.6	O0		General-purpose output
	TOM0_1	O1		GTM_TOUT
	TOM1_1			GTM_TOUT
	IOM_REF2_14			IOM reference input
	—	O2		Reserved
	QSPI2_SLSO2	O3		QSPI2 output (aka: SLSO22)
	—	O4		Reserved
	—	O5		Reserved
	ERAY0_TXENB	O6		ERAY0 output
	—	O7		Reserved
125	P14.7	I	A1 / HighZ / VDDP3	General-purpose input
	TIM0_0			GTM_TIN
	ERAY0_RXDB0			ERAY0 input
	P14.7	O0		General-purpose output
	TOM0_0	O1		GTM_TOUT
	IOM_REF2_15			IOM reference input
	ASCLIN0_RTS	O2		ASCLIN0 output (aka: ARTS0)
	QSPI2_SLSO4	O3		QSPI2 output (aka: SLSO24)
	—	O4		Reserved
	—	O5		Reserved
	—	O6		Reserved
	—	O7		Reserved

Package and Pinning Definitions PG-TQFP-144-27 Package Variant Pin

Table 2-26 Port 14 Functions (cont'd)

Pin	Symbol	Ctrl.	Buffer Type	Function
127	P14.8	I	A1 / HighZ / VDDP3	General-purpose input
	ASCLIN1_RXD			ASCLIN1 input (aka: ARX1D)
	CAN2_RXDD			CAN node 2 input (aka: RXDCAN2D)
	ERAY0_RXDA0			ERAY0 input
	P14.8	O0		General-purpose output
	TOM0_2	O1		GTM_TOUT
	—	O2		Reserved
	—	O3		Reserved
	—	O4		Reserved
	—	O5		Reserved
	—	O6		Reserved
	—	O7		Reserved

Table 2-27 Port 15 Functions

Pin	Symbol	Ctrl.	Buffer Type	Function
109	P15.0	I	A1 / HighZ / VDDP3	General-purpose input
	P15.0	O0		General-purpose output
	TOM1_3	O1		GTM_TOUT
	TOM0_11			GTM_TOUT
	TOM0_7N			GTM_TOUT (= DTM1_OUT7_N)
	TOM1_7N			GTM_TOUT (= DTM5_OUT7_N)
	ASCLIN1_TX			O2
	IOM_MON2_13	O3		IOM monitor input
	IOM_REF2_13			IOM reference input
	QSPIO_SLSO13			QSPIO output (aka: SLSO013)
	—	O4		Reserved
	CAN2_TXD	O5		CAN node 2 output (aka: TXDCAN2)
	IOM_MON2_7	O6		IOM monitor input
	IOM_REF2_7			IOM reference input
	ASCLIN1_SCLK			ASCLIN1 output (aka: ASCLK1)
	—	O7		Reserved

Table 2-27 Port 15 Functions (cont'd)

Pin	Symbol	Ctrl.	Buffer Type	Function
110	P15.1	I	A1 / HighZ / VDDP3	General-purpose input
	ASCLIN1_RXA			ASCLIN1 input (aka: ARX1A)
	QSPI2_SLSIB			QSPI2 input (aka: SLSI2B)
	CAN2_RXDA			CAN node 2 input (aka: RXDCAN2A)
	SCU_REQ16			SCU input
	SCU_EVRWUPB	AI		SCU input
	P15.1	O0		General-purpose output
	TOM1_4	O1		GTM_TOUT (= DTM5_OUT4)
	TOM0_12			GTM_TOUT
	TOM0_4			GTM_TOUT (= DTM1_OUT4)
	TOM1_4			GTM_TOUT (= DTM5_OUT4)
	ASCLIN1_TX	O2		ASCLIN1 output (aka: ATX1)
	IOM_MON2_13			IOM monitor input
	IOM_REF2_13			IOM reference input
	QSPI2_SLSO5	O3		QSPI2 output (aka: SLSO25)
	—	O4		Reserved
	—	O5		Reserved
—	O6	Reserved		
—	O7	Reserved		
111	P15.2	I	A1+ / HighZ / VDDP3	General-purpose input
	QSPI2_MRSTE			QSPI2 input (aka: MRST2E)
	QSPI2_SLSIA			QSPI2 input (aka: SLSI2A)
	QSPI2_HSICINA			QSPI2 input (aka: HSIC2INA)
	P15.2	O0		General-purpose output
	TOM1_5	O1		GTM_TOUT (= DTM5_OUT5)
	TOM0_13			GTM_TOUT
	TOM0_4N			GTM_TOUT (= DTM1_OUT4_N)
	TOM1_4N			GTM_TOUT (= DTM5_OUT4_N)
	ASCLIN0_TX	O2		ASCLIN0 output (aka: ATX0)
	IOM_MON2_12			IOM monitor input
	IOM_REF2_12			IOM reference input
	QSPI2_SLSO0	O3		QSPI2 output (aka: SLSO20)
	—	O4		Reserved
	CAN1_TXD	O5		CAN node 1 output (aka: TXDCAN1)
	IOM_MON2_6			IOM monitor input
	IOM_REF2_6			IOM reference input
ASCLIN0_SCLK	O6	ASCLIN0 output (aka: ASCLK0)		
—	O7	Reserved		

Table 2-27 Port 15 Functions (cont'd)

Pin	Symbol	Ctrl.	Buffer Type	Function
112	P15.3	I	A1+ / HighZ / VDDP3	General-purpose input
	ASCLIN0_RXB			ASCLIN0 input (aka: ARX0B)
	QSPI2_SCLKA			QSPI2 input (aka: SCLK2A)
	QSPI2_HSICINB			QSPI2 input (aka: HSIC2INB)
	CAN1_RXDA			CAN node 1 input (aka: RXDCAN1A)
	P15.3	O0		General-purpose output
	TOM1_6	O1		GTM_TOUT (= DTM5_OUT6)
	TOM0_14			GTM_TOUT
	TOM0_5			GTM_TOUT (= DTM1_OUT5)
	TOM1_5			GTM_TOUT (= DTM5_OUT5)
	ASCLIN0_TX	O2		ASCLIN0 output (aka: ATX0)
	IOM_MON2_12			IOM monitor input
	IOM_REF2_12			IOM reference input
	QSPI2_SCLK	O3		QSPI2 output (aka: SCLK2)
	—	O4		Reserved
	—	O5		Reserved
	—	O6		Reserved
—	O7	Reserved		
113	P15.4	I	A1+ / HighZ / VDDP3	General-purpose input
	QSPI2_MRSTA			QSPI2 input (aka: MRST2A)
	SCU_REQ0			SCU input
	P15.4	O0		General-purpose output
	TOM1_7	O1		GTM_TOUT (= DTM5_OUT7)
	TOM0_15			GTM_TOUT
	ASCLIN1_TX	O2		ASCLIN1 output (aka: ATX1)
	IOM_MON2_13			IOM monitor input
	IOM_REF2_13			IOM reference input
	QSPI2_MRST	O3		QSPI2 output (aka: MRST2)
	IOM_MON2_2			IOM monitor input
	IOM_REF2_2			IOM reference input
	—	O4		Reserved
	—	O5		Reserved
	—	O6		Reserved
	CCU60_CC62	O7		CCU60 output
	IOM_MON1_0			IOM monitor input
IOM_REF1_4	IOM reference input			

Table 2-27 Port 15 Functions (cont'd)

Pin	Symbol	Ctrl.	Buffer Type	Function
114	P15.5	I	A1 / HighZ / VDDP3	General-purpose input
	ASCLIN1_RXB			ASCLIN1 input (aka: ARX1B)
	QSPI2_MTSRA			QSPI2 input (aka: MTSR2A)
	SCU_REQ13			SCU input
	P15.5	O0		General-purpose output
	TOM0_0	O1		GTM_TOUT
	TOM1_0			GTM_TOUT
	TOM0_5N			GTM_TOUT (= DTM1_OUT5_N)
	TOM1_5N			GTM_TOUT (= DTM5_OUT5_N)
	ASCLIN1_TX	O2		ASCLIN1 output (aka: ATX1)
	IOM_MON2_13			IOM monitor input
	IOM_REF2_13			IOM reference input
	QSPI2_MTSR	O3		QSPI2 output (aka: MTSR2)
	—	O4		Reserved
	—	O5		Reserved
	—	O6		Reserved
	CCU60_CC61	O7		CCU60 output
	IOM_MON1_1			IOM monitor input
IOM_REF1_5	IOM reference input			
115	P15.6	I	A1 / HighZ / VDDP3	General-purpose input
	TIM0_0			GTM_TIN
	QSPI2_MTSRB			QSPI2 input (aka: MTSR2B)
	P15.6	O0		General-purpose output
	TOM0_0	O1		GTM_TOUT
	TOM1_0			GTM_TOUT
	—	O2		Reserved
	QSPI2_MTSR	O3		QSPI2 output (aka: MTSR2)
	—	O4		Reserved
	QSPI2_SCLK	O5		QSPI2 output (aka: SCLK2)
	—	O6		Reserved
	CCU60_CC60	O7		CCU60 output
	IOM_MON1_2			IOM monitor input
	IOM_REF1_6			IOM reference input

Table 2-27 Port 15 Functions (cont'd)

Pin	Symbol	Ctrl.	Buffer Type	Function
116	P15.7	I	A1 / HighZ / VDDP3	General-purpose input
	TIM0_1			GTM_TIN
	QSPI2_MRSTB			QSPI2 input (aka: MRST2B)
	P15.7	O0		General-purpose output
	TOM0_1	O1		GTM_TOUT
	TOM1_1			GTM_TOUT
	—	O2		Reserved
	QSPI2_MRST	O3		QSPI2 output (aka: MRST2)
	IOM_MON2_2			IOM monitor input
	IOM_REF2_2			IOM reference input
	—	O4		Reserved
	—	O5		Reserved
	—	O6		Reserved
	CCU60_COUT60	O7		CCU60 output
	IOM_MON1_3			IOM monitor input
IOM_REF1_3	IOM reference input			
117	P15.8	I	A1 / HighZ / VDDP3	General-purpose input
	TIM0_2			GTM_TIN
	QSPI2_SCLKB			QSPI2 input (aka: SCLK2B)
	SCU_REQ1			SCU input
	P15.8	O0		General-purpose output
	TOM0_2	O1		GTM_TOUT
	TOM1_2			GTM_TOUT
	—	O2		Reserved
	QSPI2_SCLK	O3		QSPI2 output (aka: SCLK2)
	—	O4		Reserved
	—	O5		Reserved
	—	O6		Reserved
	CCU60_COUT61	O7		CCU60 output
	IOM_MON1_4			IOM monitor input
	IOM_REF1_2			IOM reference input

Table 2-28 Port 20 Functions

Pin	Symbol	Ctrl.	Buffer Type	Function
93	P20.0	I	A1 / HighZ / VDDP3	General-purpose input
	TIM0_6			GTM_TIN
	SCU_REQ9			SCU input
	$\overline{\text{OCDS_TGI0}}$			OCDS input
	GPT120_T6EUDA			GPT120 input
	CAN11_RXDC			CAN1 node 1 input (aka: RXDCAN11C)
	CAN12_RXDC			CAN1 node 2 input (aka: RXDCAN12C)
	P20.0	O0		General-purpose output
	TOM0_6	O1		GTM_TOUT (= DTM1_OUT6)
	TOM1_6			GTM_TOUT (= DTM5_OUT6)
	—	O2		Reserved
	—	O3		Reserved
	—	O4		Reserved
	—	O5		Reserved
	—	O6		Reserved
—	O7	Reserved		
	$\overline{\text{OCDS_TGO0}}$	O	OCDS	
94	P20.2	I	Input Only / PU / VDDP3	General-purpose input
	$\overline{\text{TESTMODE}}$			Factory Test Mode Enable
95	P20.3	I	A1 / HighZ / VDDP3	General-purpose input
	TIM0_4			GTM_TIN
	GPT120_T6INA			GPT120 input
	P20.3	O0		General-purpose output
	TOM1_12	O1		GTM_TOUT
	TOM0_4			GTM_TOUT (= DTM1_OUT4)
	IOM_MON1_14			IOM monitor input
	—	O2		Reserved
	QSPIO_SLSO9	O3		QSPIO output (aka: SLSO09)
	QSPI2_SLSO9	O4		QSPI2 output (aka: SLSO29)
	CAN12_TXD	O5		CAN1 node 2 output (aka: TXDCAN12)
	—	O6		Reserved
	—	O7		Reserved

Table 2-28 Port 20 Functions (cont'd)

Pin	Symbol	Ctrl.	Buffer Type	Function	
100	P20.6	I	A1 / HighZ / VDDP3	General-purpose input	
	TIM0_6			GTM_TIN	
	P20.6	O0		General-purpose output	
	TOM1_10	O1		GTM_TOUT	
	TOM0_10			GTM_TOUT	
	IOM_MON1_15	O2		IOM monitor input	
	ASCLIN1_RTS			ASCLIN1 output (aka: ARTS1)	
	QSPI0_SLSO8			QSPI0 output (aka: SLSO08)	
	QSPI2_SLSO8			QSPI2 output (aka: SLSO28)	
	—			O5	Reserved
	—			O6	Reserved
—	O7		Reserved		
101	P20.7	I	A1 / HighZ / VDDP3	General-purpose input	
	TIM0_7			GTM_TIN	
	ASCLIN1_CTSA			ASCLIN1 input (aka: ACTS1A)	
	CAN0_RXDB			CAN node 0 input (aka: RXDCAN0B)	
	P20.7	O0		General-purpose output	
	TOM1_11	O1		GTM_TOUT	
	TOM0_11			GTM_TOUT	
	IOM_MON2_4	O2		IOM monitor input	
	—			Reserved	
	—			Reserved	
	—			Reserved	
	—			Reserved	
	—			Reserved	
	—			Reserved	
	CCU61_COUT63	O7		CCU61 output	
IOM_MON1_7	IOM monitor input				
IOM_REF1_7	IOM reference input				

Package and Pinning Definitions PG-TQFP-144-27 Package Variant Pin

Table 2-28 Port 20 Functions (cont'd)

Pin	Symbol	Ctrl.	Buffer Type	Function
102	P20.8	I	A1 / HighZ / VDDP3	General-purpose input
	TIM0_7			GTM_TIN
	P20.8	O0		General-purpose output
	TOM1_7	O1		GTM_TOUT (= DTM5_OUT7)
	TOM0_7			GTM_TOUT (= DTM1_OUT7)
	TOM0_4			GTM_TOUT (= DTM1_OUT4)
	TOM1_4			GTM_TOUT (= DTM5_OUT4)
	IOM_MON2_8			IOM monitor input
	ASCLIN1_SLSO	O2		ASCLIN1 output (aka: ASLSO1)
	QSPI0_SLSO0	O3		QSPI0 output (aka: SLSO00)
	QSPI1_SLSO0	O4		QSPI1 output (aka: SLSO10)
	CAN0_TXD	O5		CAN node 0 output (aka: TXDCAN0)
	IOM_MON2_5			IOM monitor input
	IOM_REF2_5			IOM reference input
	SCU_WDT0LCK	O6		SCU output
	CCU61_CC60	O7		CCU61 output
	IOM_MON1_8			IOM monitor input
IOM_REF1_13	IOM reference input			
103	P20.9	I	A1 / HighZ / VDDP3	General-purpose input
	ASCLIN1_RXC			ASCLIN1 input (aka: ARX1C)
	QSPI0_SLSIB			QSPI0 input (aka: SLSI0B)
	SCU_REQ11			SCU input
	CAN12_RXDE			CAN1 node 2 input (aka: RXDCAN12E)
	P20.9	O0		General-purpose output
	TOM1_13	O1		GTM_TOUT
	TOM0_13			GTM_TOUT
	TOM0_4N			GTM_TOUT (= DTM1_OUT4_N)
	TOM1_4N			GTM_TOUT (= DTM5_OUT4_N)
	IOM_MON2_11			IOM monitor input
	—	O2		Reserved
	QSPI0_SLSO1	O3		QSPI0 output (aka: SLSO01)
	QSPI1_SLSO1	O4		QSPI1 output (aka: SLSO11)
	—	O5		Reserved
	SCU_WDTSLCK	O6		SCU output
	CCU61_CC61	O7		CCU61 output
IOM_MON1_9	IOM monitor input			
IOM_REF1_12	IOM reference input			

Table 2-28 Port 20 Functions (cont'd)

Pin	Symbol	Ctrl.	Buffer Type	Function
104	P20.10	I	A1 / HighZ / VDDP3	General-purpose input
	P20.10	O0		General-purpose output
	TOM1_14	O1		GTM_TOUT
	TOM0_14			GTM_TOUT
	TOM0_5			GTM_TOUT (= DTM1_OUT5)
	TOM1_5			GTM_TOUT (= DTM5_OUT5)
	IOM_MON2_14			IOM monitor input
	ASCLIN1_TX			O2
	IOM_MON2_13	O2		IOM monitor input
	IOM_REF2_13			IOM reference input
	QSPI0_SLSO6			O3
	QSPI2_SLSO7	O4		QSPI2 output (aka: SLSO27)
	CAN12_TXD	O5		CAN1 node 2 output (aka: TXDCAN12)
	ASCLIN1_SCLK	O6		ASCLIN1 output (aka: ASCLK1)
	CCU61_CC62	O7		CCU61 output
	IOM_MON1_10	O7		IOM monitor input
	IOM_REF1_11			IOM reference input
105	P20.11	I	A1+ / HighZ / VDDP3	General-purpose input
	QSPI0_SCLKA	O0		QSPI0 input (aka: SCLK0A)
	P20.11			General-purpose output
	TOM1_15	O1		GTM_TOUT
	TOM0_15			GTM_TOUT
	TOM0_5N			GTM_TOUT (= DTM1_OUT5_N)
	TOM1_5N			GTM_TOUT (= DTM5_OUT5_N)
	IOM_MON2_15			IOM monitor input
	—			O2
	QSPI0_SCLK	O3		QSPI0 output (aka: SCLK0)
	—	O4		Reserved
	CAN11_TXD	O5		CAN1 node 1 output (aka: TXDCAN11)
	—	O6		Reserved
	CCU61_COUT60	O7		CCU61 output
	IOM_MON1_11	O7		IOM monitor input
	IOM_REF1_10			IOM reference input

Package and Pinning Definitions PG-TQFP-144-27 Package Variant Pin

Table 2-28 Port 20 Functions (cont'd)

Pin	Symbol	Ctrl.	Buffer Type	Function
106	P20.12	I	A1 / HighZ / VDDP3	General-purpose input
	QSPIO_MRSTA			QSPIO input (aka: MRST0A)
	CAN11_RXDH			CAN1 node 1 input (aka: RXDCAN11H)
	IOM_PIN13			IOM pad input
	P20.12	O0		General-purpose output
	TOM1_0	O1		GTM_TOUT
	TOM0_8		GTM_TOUT	
	TOM0_6		GTM_TOUT (= DTM1_OUT6)	
	TOM1_6		GTM_TOUT (= DTM5_OUT6)	
	IOM_MON0_13		IOM monitor input	
	—		O2	
	QSPIO_MRST	O3		QSPIO output (aka: MRST0)
	IOM_MON2_0		IOM monitor input	
	IOM_REF2_0		IOM reference input	
	QSPIO_MTSR	O4		QSPIO output (aka: MTSR0)
	—	O5		Reserved
	—	O6		Reserved
	CCU61_COUT61	O7		CCU61 output
	IOM_MON1_12		IOM monitor input	
	IOM_REF1_9		IOM reference input	
107	P20.13	I	A1+ / HighZ / VDDP3	General-purpose input
	QSPIO_SLSIA			QSPIO input (aka: SLSI0A)
	CAN12_RXDH			CAN1 node 2 input (aka: RXDCAN12H)
	IOM_PIN14			IOM pad input
	P20.13	O0		General-purpose output
	TOM1_1	O1		GTM_TOUT
	TOM0_9		GTM_TOUT	
	TOM0_6N		GTM_TOUT (= DTM1_OUT6_N)	
	TOM1_6N		GTM_TOUT (= DTM5_OUT6_N)	
	IOM_MON0_14		IOM monitor input	
	—		O2	
	QSPIO_SLSO2	O3		QSPIO output (aka: SLSO02)
	QSPIO1_SLSO2	O4		QSPIO1 output (aka: SLSO12)
	QSPIO_SCLK	O5		QSPIO output (aka: SCLK0)
	—	O6		Reserved
	CCU61_COUT62	O7		CCU61 output
	IOM_MON1_13		IOM monitor input	
	IOM_REF1_8		IOM reference input	

Table 2-28 Port 20 Functions (cont'd)

Pin	Symbol	Ctrl.	Buffer Type	Function
108	P20.14	I	A1+ / HighZ / VDDP3	General-purpose input
	QSPI0_MTSRA			QSPI0 input (aka: MTSR0A)
	IOM_PIN15			IOM pad input
	P20.14	O0		General-purpose output
	TOM1_2	O1		GTM_TOUT
	TOM0_10			GTM_TOUT
	TOM0_7			GTM_TOUT (= DTM1_OUT7)
	TOM1_7			GTM_TOUT (= DTM5_OUT7)
	IOM_MON0_15			IOM monitor input
	—	O2		Reserved
	QSPI0_MTSR	O3		QSPI0 output (aka: MTSR0)
	—	O4		Reserved
	CAN12_TXD	O5		CAN1 node 2 output (aka: TXDCAN12)
	—	O6		Reserved
	—	O7		Reserved

Table 2-29 Port 21 Functions

Pin	Symbol	Ctrl.	Buffer Type	Function
84	P21.2	I	A1 / HighZ / VDDP3	General-purpose input
	TIM0_0			GTM_TIN
	SCU_EMGSTOPB			SCU input
	P21.2	O0		General-purpose output
	TOM0_0	O1		GTM_TOUT
	TOM1_0			GTM_TOUT
	TOM0_4			GTM_TOUT (= DTM1_OUT4)
	TOM1_4			GTM_TOUT (= DTM5_OUT4)
	—	O2		Reserved
	—	O3		Reserved
	—	O4		Reserved
	ETH0_MDC	O5		Ethernet output
	—	O6		Reserved
—	O7	Reserved		

Table 2-29 Port 21 Functions (cont'd)

Pin	Symbol	Ctrl.	Buffer Type	Function
85	P21.3	I	A1 / HighZ / VDDP3	General-purpose input
	TIM0_1			GTM_TIN
	ETH0_MDIOD			Ethernet input
	P21.3	O0		General-purpose output
	TOM0_1	O1		GTM_TOUT
	TOM1_1			GTM_TOUT
	TOM0_4N			GTM_TOUT (= DTM1_OUT4_N)
	TOM1_4N			GTM_TOUT (= DTM5_OUT4_N)
	—	O2		Reserved
	—	O3		Reserved
	—	O4		Reserved
	—	O5		Reserved
	—	O6		Reserved
	—	O7		Reserved
	ETH0_MDIO	O		Ethernet output
86	P21.4	I	A1 / HighZ / VDDP3	General-purpose input
	TIM0_2			GTM_TIN
	P21.4			General-purpose output
	TOM0_2	O1		GTM_TOUT
	TOM1_2			GTM_TOUT
	TOM0_5			GTM_TOUT (= DTM1_OUT5)
	TOM1_5			GTM_TOUT (= DTM5_OUT5)
	—	O2		Reserved
	—	O3		Reserved
	—	O4		Reserved
	—	O5		Reserved
	—	O6		Reserved
	—	O7		Reserved

Table 2-29 Port 21 Functions (cont'd)

Pin	Symbol	Ctrl.	Buffer Type	Function
87	P21.5	I	A1 / HighZ / VDDP3	General-purpose input
	TIM0_3			GTM_TIN
	P21.5	O0		General-purpose output
	TOM0_3	O1		GTM_TOUT
	TOM1_3			GTM_TOUT
	TOM0_5N			GTM_TOUT (= DTM1_OUT5_N)
	TOM1_5N			GTM_TOUT (= DTM5_OUT5_N)
	—	O2		Reserved
	—	O3		Reserved
	—	O4		Reserved
	—	O5		Reserved
	—	O6		Reserved
	—	O7		Reserved
	88	P21.6		I
TIM0_4		GTM_TIN		
TDI		OCDS input		
OCDS_TGI2		OCDS input		
GPT120_T5EUDA		GPT120 input		
P21.6		O0	General-purpose output	
TOM0_4		O1	GTM_TOUT (= DTM1_OUT4)	
TOM1_4			GTM_TOUT (= DTM5_OUT4)	
—		O2	Reserved	
—		O3	Reserved	
—		O4	Reserved	
—		O5	Reserved	
—		O6	Reserved	
GPT120_T3OUT		O7	GPT120 output	
OCDS_TGO2	O	OCDS		

Package and Pinning Definitions PG-TQFP-144-27 Package Variant Pin

Table 2-29 Port 21 Functions (cont'd)

Pin	Symbol	Ctrl.	Buffer Type	Function
90	P21.7	I	A1+ / PU / VDDP3	General-purpose input
	TIM0_5			GTM_TIN
	OCDS_DAP2			OCDS input
	OCDS_TGI3			OCDS input
	GPT120_T5INA			GPT120 input
	ETH0_RXERB			Ethernet input
	P21.7	O0	General-purpose output	
	TOM0_5	O1	GTM_TOUT (= DTM1_OUT5)	
	TOM1_5		GTM_TOUT (= DTM5_OUT5)	
	—	O2	Reserved	
	—	O3	Reserved	
	—	O4	Reserved	
	—	O5	Reserved	
	—	O6	Reserved	
	GPT120_T6OUT	O7	GPT120 output	
	OCDS_TGO3	O	OCDS	
	OCDS_DAP2	O	OCDS Output	
	TDO	O	JTAG Output	

Table 2-30 Port 22 Functions

Pin	Symbol	Ctrl.	Buffer Type	Function
74	P22.0	I	A1 / HighZ / VDDP3	General-purpose input
	TIM0_1			GTM_TIN
	QSPI3_MTSRE			QSPI3 input (aka: MTSR3E)
	P22.0	O0	General-purpose output	
	TOM0_9	O1	GTM_TOUT	
	TOM1_1		GTM_TOUT	
	—	O2	Reserved	
	QSPI3_MTSR	O3	QSPI3 output (aka: MTSR3)	
	—	O4	Reserved	
	—	O5	Reserved	
	—	O6	Reserved	
	—	O7	Reserved	

Table 2-30 Port 22 Functions (cont'd)

Pin	Symbol	Ctrl.	Buffer Type	Function
75	P22.1	I	A1 / HighZ / VDDP3	General-purpose input
	TIM0_0			GTM_TIN
	QSPI3_MRSTE			QSPI3 input (aka: MRST3E)
	P22.1	O0		General-purpose output
	TOM0_8	O1		GTM_TOUT
	TOM1_0			GTM_TOUT
	TOM0_6			GTM_TOUT (= DTM1_OUT6)
	TOM1_6			GTM_TOUT (= DTM5_OUT6)
	—	O2		Reserved
	QSPI3_MRST	O3		QSPI3 output (aka: MRST3)
	IOM_MON2_3	O4		IOM monitor input
	IOM_REF2_3			IOM reference input
	—			Reserved
	—	O5		Reserved
	—	O6		Reserved
—	O7	Reserved		
76	P22.2	I	A1 / HighZ / VDDP3	General-purpose input
	TIM0_3			GTM_TIN
	QSPI3_SLSID			QSPI3 input (aka: SLSI3D)
	P22.2	O0		General-purpose output
	TOM0_11	O1		GTM_TOUT
	TOM1_3			GTM_TOUT
	TOM0_6N			GTM_TOUT (= DTM1_OUT6_N)
	TOM1_6N			GTM_TOUT (= DTM5_OUT6_N)
	—	O2		Reserved
	QSPI3_SLSO12	O3		QSPI3 output (aka: SLSO312)
	—	O4		Reserved
	—	O5		Reserved
	—	O6		Reserved
	—	O7		Reserved

Table 2-30 Port 22 Functions (cont'd)

Pin	Symbol	Ctrl.	Buffer Type	Function
77	P22.3	I	A1 / HighZ / VDDP3	General-purpose input
	TIM0_4			GTM_TIN
	QSPI3_SCLKE			QSPI3 input (aka: SCLK3E)
	P22.3	O0		General-purpose output
	TOM0_12	O1		GTM_TOUT
	TOM1_4			GTM_TOUT (= DTM5_OUT4)
	TOM0_7			GTM_TOUT (= DTM1_OUT7)
	TOM1_7			GTM_TOUT (= DTM5_OUT7)
	—	O2		Reserved
	QSPI3_SCLK	O3		QSPI3 output (aka: SCLK3)
	—	O4		Reserved
	—	O5		Reserved
	—	O6		Reserved
	—	O7		Reserved
78	P22.4	I	A1 / HighZ / VDDP3	General-purpose input
	P22.4	O0		General-purpose output
	TOM0_7N	O1		GTM_TOUT (= DTM1_OUT7_N)
	TOM1_7N			GTM_TOUT (= DTM5_OUT7_N)
	—	O2		Reserved
	—	O3		Reserved
	QSPI0_SLSO12	O4		QSPI0 output (aka: SLSO012)
	—	O5		Reserved
	—	O6		Reserved
	—	O7		Reserved

Table 2-31 Port 23 Functions

Pin	Symbol	Ctrl.	Buffer Type	Function
73	P23.1	I	A1+ / HighZ / VDDP3	General-purpose input
	TIM0_6			GTM_TIN
	P23.1			O0
	TOM0_6	O1		GTM_TOUT (= DTM1_OUT6)
	TOM0_15			GTM_TOUT
	ASCLIN1_RTS	O2		ASCLIN1 output (aka: ARTS1)
	QSPI3_SLSO13	O3		QSPI3 output (aka: SLSO313)
	GTM_CLK0	O4		GTM output
	SCU_EXTCLK1	O5		SCU output
	SCU_EXTCLK0	O6		SCU output
	—	O7		Reserved

Table 2-32 Port 33 Functions

Pin	Symbol	Ctrl.	Buffer Type	Function
56	P33.0	I	A1 / HighZ / VDDP3	General-purpose input
	TIM0_4			GTM_TIN
	IOM_PIN0			IOM pad input
	P33.0	O0		General-purpose output
	TOM0_4	O1		GTM_TOUT (= DTM1_OUT4)
	TOM1_4			GTM_TOUT (= DTM5_OUT4)
	IOM_MON0_0	O2		IOM monitor input
	—			Reserved
	—			Reserved
	—	O3		Reserved
	—	O4		Reserved
	—	O5		Reserved
	VADC_G1BFL0	O6		VADC output
—	O7	Reserved		

Table 2-32 Port 33 Functions (cont'd)

Pin	Symbol	Ctrl.	Buffer Type	Function
57	P33.1	I	A1 / HighZ / VDDP3	General-purpose input
	TIM0_5			GTM_TIN
	IOM_PIN1			IOM pad input
	P33.1	O0		General-purpose output
	TOM0_5	O1		GTM_TOUT (= DTM1_OUT5)
	TOM1_5			GTM_TOUT (= DTM5_OUT5)
	IOM_MON0_1	IOM monitor input		
	—	O2		Reserved
	—	O3		Reserved
	—	O4		Reserved
	VADC_EMUX02	O5		VADC output
	VADC_G1BFL1	O6		VADC output
	—	O7		Reserved
58	P33.2	I	A1 / HighZ / VDDP3	General-purpose input
	TIM0_6			GTM_TIN
	IOM_PIN2			IOM pad input
	P33.2	O0		General-purpose output
	TOM0_6	O1		GTM_TOUT (= DTM1_OUT6)
	TOM1_6			GTM_TOUT (= DTM5_OUT6)
	IOM_MON0_2	IOM monitor input		
	—	O2		Reserved
	—	O3		Reserved
	—	O4		Reserved
	VADC_EMUX01	O5		VADC output
	VADC_G1BFL2	O6		VADC output
	CCU61_COUT63	O7		CCU61 output
	IOM_MON1_7			IOM monitor input
IOM_REF1_7	IOM reference input			

Table 2-32 Port 33 Functions (cont'd)

Pin	Symbol	Ctrl.	Buffer Type	Function
59	P33.3	I	A1 / HighZ / VDDP3	General-purpose input
	TIM0_7			GTM_TIN
	IOM_PIN3			IOM pad input
	P33.3	O0		General-purpose output
	TOM0_7	O1		GTM_TOUT (= DTM1_OUT7)
	TOM1_7			GTM_TOUT (= DTM5_OUT7)
	IOM_MON0_3			IOM monitor input
	—	O2		Reserved
	—	O3		Reserved
	—	O4		Reserved
	VADC_EMUX00	O5		VADC output
	VADC_G1BFL3	O6		VADC output
	CCU61_CC60	O7		CCU61 output
	IOM_MON1_8			IOM monitor input
IOM_REF1_13	IOM reference input			
60	P33.4	I	A1 / HighZ / VDDP3	General-purpose input
	TIM0_0			GTM_TIN
	CCU61_CTRAPC			CCU61 input
	IOM_PIN4			IOM pad input
	P33.4	O0		General-purpose output
	TOM0_0	O1		GTM_TOUT
	TOM1_0			GTM_TOUT
	IOM_MON0_4			IOM monitor input
	—	O2		Reserved
	—	O3		Reserved
	—	O4		Reserved
	VADC_EMUX12	O5		VADC output
	VADC_G0BFL0	O6		VADC output
	—	O7		Reserved

Table 2-32 Port 33 Functions (cont'd)

Pin	Symbol	Ctrl.	Buffer Type	Function
61	P33.5	I	A1 / HighZ / VDDP3	General-purpose input
	TIM0_1			GTM_TIN
	CCU61_CCPOS2C			CCU61 input
	GPT120_T4EUDB			GPT120 input
	IOM_PIN5			IOM pad input
	P33.5	O0		General-purpose output
	TOM0_1	O1		GTM_TOUT
	TOM1_1			GTM_TOUT
	TOM0_5			GTM_TOUT (= DTM1_OUT5)
	TOM1_5			GTM_TOUT (= DTM5_OUT5)
	IOM_MON0_5			IOM monitor input
	QSPI0_SLSO7	O2		QSPI0 output (aka: SLSO07)
	QSPI1_SLSO7	O3		QSPI1 output (aka: SLSO17)
	—	O4		Reserved
	VADC_EMUX11	O5		VADC output
	VADC_G0BFL1	O6		VADC output
	CCU61_CC60	O7		CCU61 output
	IOM_MON1_8			IOM monitor input
	IOM_REF1_13			IOM reference input

Table 2-32 Port 33 Functions (cont'd)

Pin	Symbol	Ctrl.	Buffer Type	Function
62	P33.6	I	A1 / HighZ / VDDP3	General-purpose input
	TIM0_2			GTM_TIN
	ASCLIN1_RXF			ASCLIN1 input (aka: ARX1F)
	CCU61_CCPOS1C			CCU61 input
	GPT120_T2EUDB			GPT120 input
	CAN10_RXDH			CAN1 node 0 input (aka: RXDCAN10H)
	IOM_PIN6			IOM pad input
	P33.6	O0	General-purpose output	
	TOM0_2	O1	GTM_TOUT	
	TOM1_2		GTM_TOUT	
	TOM0_5N		GTM_TOUT (= DTM1_OUT5_N)	
	TOM1_5N		GTM_TOUT (= DTM5_OUT5_N)	
	IOM_MON0_6		IOM monitor input	
	—		O2	Reserved
	—	O3	Reserved	
	ASCLIN1_TX	O4	ASCLIN1 output (aka: ATX1)	
	IOM_MON2_13	O5	IOM monitor input	
	IOM_REF2_13		IOM reference input	
	VADC_EMUX10		VADC output	
	VADC_G0BFL2	O6	VADC output	
	CCU61_CC61	O7	CCU61 output	
	IOM_MON1_9		IOM monitor input	
	IOM_REF1_12		IOM reference input	
HSM_HSM1	O		HSM output	

Table 2-32 Port 33 Functions (cont'd)

Pin	Symbol	Ctrl.	Buffer Type	Function
63	P33.7	I	A1+ / HighZ / VDDP3	General-purpose input
	TIM0_3			GTM_TIN
	CAN0_RXDE			CAN node 0 input (aka: RXDCAN0E)
	SCU_REQ8			SCU input
	CCU61_CCPOS0C			CCU61 input
	GPT120_T2INB			GPT120 input
	IOM_PIN7			IOM pad input
	P33.7	O0	General-purpose output	
	TOM0_3	O1	GTM_TOUT	
	TOM1_3		GTM_TOUT	
	TOM0_6		GTM_TOUT (= DTM1_OUT6)	
	TOM1_6		GTM_TOUT (= DTM5_OUT6)	
	IOM_MON0_7		IOM monitor input	
	—	O2	Reserved	
	QSPI3_SLSO7	O3	QSPI3 output (aka: SLSO37)	
	—	O4	Reserved	
	CAN10_TXD	O5	CAN1 node 0 output (aka: TXDCAN10)	
	VADC_G0BFL3	O6	VADC output	
	CCU61_COUT60	O7	CCU61 output	
	IOM_MON1_11		IOM monitor input	
IOM_REF1_10	IOM reference input			
HSM_HSM2	O	HSM output		

Table 2-32 Port 33 Functions (cont'd)

Pin	Symbol	Ctrl.	Buffer Type	Function
64	P33.8	I	A1+ / HighZ / VDDP3	General-purpose input
	TIM0_4			GTM_TIN
	SCU_EMGSTOPA			SCU input
	IOM_PIN8			IOM pad input
	P33.8	O0		General-purpose output
	TOM0_4	O1		GTM_TOUT (= DTM1_OUT4)
	TOM1_4			GTM_TOUT (= DTM5_OUT4)
	TOM0_6N			GTM_TOUT (= DTM1_OUT6_N)
	TOM1_6N			GTM_TOUT (= DTM5_OUT6_N)
	IOM_MON0_8	O2		IOM monitor input
	—			Reserved
	QSPI3_SLSO2	O3		QSPI3 output (aka: SLSO32)
	—	O4		Reserved
	CAN0_TXD	O5		CAN node 0 output (aka: TXDCAN0)
	IOM_MON2_5			IOM monitor input
	IOM_REF2_5			IOM reference input
	—	O6		Reserved
	CCU61_COUT62	O7		CCU61 output
	IOM_MON1_13			IOM monitor input
	IOM_REF1_8			IOM reference input
SMU_FSP	O	SMU		

Package and Pinning Definitions PG-TQFP-144-27 Package Variant Pin

Table 2-32 Port 33 Functions (cont'd)

Pin	Symbol	Ctrl.	Buffer Type	Function	
65	P33.9	I	A1 / HighZ / VDDP3	General-purpose input	
	TIM0_1			GTM_TIN	
	QSPI3_HSICINA			QSPI3 input	
	IOM_PIN9			IOM pad input	
	P33.9	O0		General-purpose output	
	TOM0_1	O1		GTM_TOUT	
	TOM1_1			GTM_TOUT	
	TOM0_7			GTM_TOUT (= DTM1_OUT7)	
	TOM1_7			GTM_TOUT (= DTM5_OUT7)	
	IOM_MON0_9			IOM monitor input	
	—			O2	Reserved
	QSPI3_SLSO1			O3	QSPI3 output (aka: SLSO31)
	—			O4	Reserved
	—	O5		Reserved	
	—	O6		Reserved	
	CCU61_CC62	O7		CCU61 output	
	IOM_MON1_10			IOM monitor input	
	IOM_REF1_11			IOM reference input	
	66	P33.10		I	A1+ / HighZ / VDDP3
TIM0_0		GTM_TIN			
QSPI3_SLSIC		QSPI3 input (aka: SLSI3C)			
QSPI3_HSICINB		QSPI3 input			
IOM_PIN10		IOM pad input			
P33.10		O0	General-purpose output		
TOM0_0		O1	GTM_TOUT		
TOM1_0			GTM_TOUT		
TOM0_7N			GTM_TOUT (= DTM1_OUT7_N)		
TOM1_7N			GTM_TOUT (= DTM5_OUT7_N)		
IOM_MON0_10			IOM monitor input		
QSPI1_SLSO6			O2	QSPI1 output (aka: SLSO16)	
QSPI3_SLSO11			O3	QSPI3 output (aka: SLSO311)	
ASCLIN1_SLSO			O4	ASCLIN1 output (aka: ASLSO1)	
GTM_CLK1		O5	GTM output		
SCU_EXTCLK1		O6	SCU output		
CCU61_COUT61		O7	CCU61 output		
IOM_MON1_12			IOM monitor input		
IOM_REF1_9			IOM reference input		

Package and Pinning Definitions PG-TQFP-144-27 Package Variant Pin

Table 2-32 Port 33 Functions (cont'd)

Pin	Symbol	Ctrl.	Buffer Type	Function
67	P33.11	I	A1 / HighZ / VDDP3	General-purpose input
	TIM0_2			GTM_TIN
	QSPI3_SCLKD			QSPI3 input (aka: SCLK3D)
	SCU_REQ17			SCU input
	IOM_PIN11			IOM pad input
	P33.11			O0
	TOM0_2	O1		GTM_TOUT
	TOM1_2			GTM_TOUT
	IOM_MON0_11	IOM monitor input		
	ASCLIN1_SCLK	O2		ASCLIN1 output (aka: ASCLK1)
	QSPI3_SCLK	O3		QSPI3 output (aka: SCLK3)
	—	O4		Reserved
	—	O5		Reserved
	SMPS_DCDCSYNC	O6		SCU output
	CCU61_CC61	O7		CCU61 output
	IOM_MON1_9			IOM monitor input
	IOM_REF1_12	IOM reference input		
SMPS_DCDCSYNC	O	SCU output		
68	P33.12	I	A1 / HighZ / VDDP3	General-purpose input
	TIM0_0			GTM_TIN
	QSPI3_MTSRD			QSPI3 input (aka: MTSR3D)
	IOM_PIN12			IOM pad input
	P33.12	O0		General-purpose output
	TOM1_12	O1		GTM_TOUT
	TOM0_12			GTM_TOUT
	IOM_MON0_12	IOM monitor input		
	ASCLIN1_TX	O2		ASCLIN1 output (aka: ATX1)
	IOM_MON2_13			IOM monitor input
	IOM_REF2_13			IOM reference input
	QSPI3_MTSR	O3		QSPI3 output (aka: MTSR3)
	ASCLIN1_SCLK	O4		ASCLIN1 output (aka: ASCLK1)
	—	O5		Reserved
	—	O6		Reserved
	CCU61_COUT60	O7		CCU61 output
	IOM_MON1_11			IOM monitor input
IOM_REF1_10	IOM reference input			

Table 2-33 Port 34 Functions

Pin	Symbol	Ctrl.	Buffer Type	Function
52	P34.0	I	A1 / HighZ / VDDP3	General-purpose input
	P34.0	O0		General-purpose output
	TOM1_12	O1		GTM_TOUT
	—	O2		Reserved
	—	O3		Reserved
	—	O4		Reserved
	—	O5		Reserved
	—	O6		Reserved
	—	O7		Reserved
53	P34.1	I	A1 / HighZ / VDDP3	General-purpose input
	P34.1	O0		General-purpose output
	TOM1_13	O1		GTM_TOUT
	ASCLIN0_TX	O2		ASCLIN0 output (aka: ATX0)
	IOM_MON2_12			IOM monitor input
	IOM_REF2_12			IOM reference input
	—	O3		Reserved
	CAN0_TXD	O4		CAN node 0 output (aka: TXDCAN0)
	IOM_MON2_5	O5		IOM monitor input
	IOM_REF2_5			IOM reference input
	—			Reserved
	—	O6		Reserved
	—	O7		Reserved
54	P34.2	I	A1 / HighZ / VDDP3	General-purpose input
	ASCLIN0_RXD	O0		ASCLIN0 input (aka: ARX0D)
	CAN0_RXDG			CAN node 0 input (aka: RXDCAN0G)
	P34.2			General-purpose output
	TOM1_14	O1		GTM_TOUT
	—	O2		Reserved
	—	O3		Reserved
	—	O4		Reserved
	—	O5		Reserved
	—	O6		Reserved
	—	O7		Reserved

Table 2-33 Port 34 Functions (cont'd)

Pin	Symbol	Ctrl.	Buffer Type	Function
55	P34.3	I	A1 / HighZ / VDDP3	General-purpose input
	ASCLIN1_CTSB			ASCLIN1 input (aka: ACTS1B)
	P34.3	O0		General-purpose output
	TOM1_15	O1		GTM_TOUT
	—	O2		Reserved
	—	O3		Reserved
	QSPI2_SLSO10	O4		QSPI2 output (aka: SLSO210)
	—	O5		Reserved
	—	O6		Reserved
	—	O7		Reserved

Table 2-34 Port 40 Functions

Pin	Symbol	Ctrl.	Buffer Type	Function
51	P40.0	I	S / VDDM	General-purpose input
	VADCG0_0	AI		VADC input channel 0 of group 0
50	P40.1	I	S / VDDM	General-purpose input
	VADCG0_1	AI		VADC input channel 1 of group 0 (with multiplexer diagnostics)
	VADCG2_0			VADC input channel 0 of group 2
49	P40.2	I	S / VDDM	General-purpose input
	VADCG0_2	AI		VADC input channel 2 of group 0 (with multiplexer diagnostics)
48	P40.3	I	S / VDDM	General-purpose input
	VADCG0_3	AI		VADC input channel 3 of group 0
47	P40.4	I	S / VDDM	General-purpose input
	VADCG0_4	AI		VADC input channel 4 of group 0
46	P40.5	I	S / VDDM	General-purpose input
	VADCG0_5	AI		VADC input channel 5 of group 0
45	P40.6	I	S / VDDM	General-purpose input
	VADCG0_6	AI		VADC input channel 6 of group 0
40	P40.7	I	S / VDDM	General-purpose input
	VADCG0_7	AI		VADC input channel 7 of group 0 (with pull down diagnostics)
39	P40.8	I	S / VDDM	General-purpose input
	VADCG0_8	AI		VADC input channel 8 of group 0
38	P40.9	I	S / VDDM	General-purpose input
	VADCG0_9	AI		VADC input channel 9 of group 0 (with multiplexer diagnostics)

Package and Pinning Definitions PG-TQFP-144-27 Package Variant Pin

Table 2-34 Port 40 Functions (cont'd)

Pin	Symbol	Ctrl.	Buffer Type	Function
37	P40.10	I	S / VDDM	General-purpose input
	VADCG0_10	AI		VADC input channel 10 of group 0 (with multiplexer diagnostics)
36	P40.11	I	S / VDDM	General-purpose input
	SENT_SENT0A			SENT input
	CCU60_CCPOS0D			CCU60 input
	VADCG0_11	AI		VADC input channel 11 of group 0

Table 2-35 Port 41 Functions

Pin	Symbol	Ctrl.	Buffer Type	Function
35	P41.0	I	S / VDDM	General-purpose input
	SENT_SENT1A			SENT input
	CCU60_CCPOS1B			CCU60 input
	VADCG1_0	AI	VADC input channel 0 of group 1	
34	P41.1	I	S / VDDM	General-purpose input
	VADCG1_1	AI		VADC input channel 1 of group 1 (with multiplexer diagnostics)
	VADCG3_0			VADC input channel 0 of group 3
33	P41.2	I	S / VDDM	General-purpose input
	SENT_SENT2A			SENT input
	CCU61_CCPOS1B			CCU61 input
	VADCG1_2	AI	VADC input channel 2 of group 1 (with multiplexer diagnostics)	
32	P41.3	I	S / VDDM	General-purpose input
	SENT_SENT3A			SENT input
	CCU61_CCPOS1D			CCU61 input
	VADCG1_3	AI	VADC input channel 3 of group 1 (with pull down diagnostics)	
31	P41.4	I	S / VDDM	General-purpose input
	VADCG1_4	AI		VADC input channel 4 of group 1
30	P41.5	I	S / VDDM	General-purpose input
	VADCG1_5	AI		VADC input channel 5 of group 1
29	P41.6	I	S / VDDM	General-purpose input
	VADCG1_6	AI		VADC input channel 6 of group 1
28	P41.7	I	S / VDDM	General-purpose input
	VADCG1_7	AI		VADC input channel 7 of group 1
27	P41.8	I	S / VDDM	General-purpose input
	VADCG1_8	AI		VADC input channel 8 of group 1

Package and Pinning Definitions PG-TQFP-144-27 Package Variant Pin

Table 2-35 Port 41 Functions (cont'd)

Pin	Symbol	Ctrl.	Buffer Type	Function
26	P41.9	I	S / VDDM	General-purpose input
	VADCG1_9	AI		VADC input channel 9 of group 1 (with multiplexer diagnostics)
25	P41.10	I	S / VDDM	General-purpose input
	VADCG1_10	AI		VADC input channel 10 of group 1 (with multiplexer diagnostics)
24	P41.11	I	S / VDDM	General-purpose input
	VADCG1_11	AI		VADC input channel 11 of group 1

Table 2-36 System I/O

Pin	Symbol	Ctrl.	Buffer Type	Function
81	XTAL1	I	VDDP3	Main Oscillator/PLL/Clock Generator Input
82	XTAL2	O	VDDP3	Main Oscillator/PLL/Clock Generator Output
89	TMS/DAP1	I	A1+ / PD / VDDP3	Debug Interface
	DAP1	I/O	VDDP3	Device Access Port Line 1
91	$\overline{\text{TRST}}$	I	Input Only / PD / VDDP3	JTAG Module Reset/Enable Input
92	TCK/DAP0	I	Input Only / PD / VDDP3	OCDS input
	DAP0	I	VDDP3	Device Access Port Line 0
96	$\overline{\text{ESR1}}$	I/O	A1+ / PU / VDDP3	SCU input
	EVRWUP	I	VDDP3	EVR Wakeup Pin
97	$\overline{\text{PORST}}$	I	Input Only / PD / VDDP3	Power On Reset Additional strong PD in case of power fail.
98	$\overline{\text{ESR0}}$	I/O	A1+ / OD / VDDP3	SCU input/output
	EVRWUP	I	VDDP3	EVR Wakeup Pin

Table 2-37 Supply

Pin	Symbol	Ctrl.	Buffer Type	Function
41	V _{AGND}	I	—	Negative Analog Reference Voltage 0
42	V _{AREF}	I	—	Positive Analog Reference Voltage 0
126	V _{DDP3}	I	—	Digital I/O Power Supply (3.3V) This pin supplies also the Flash 3.3V.
69	V _{DDP3}	I	—	Digital I/O Power Supply (3.3V)
70	V _{DD}	I	—	Digital Core Power Supply (1.3V) Output of EVR13.

Table 2-37 Supply (cont'd)

Pin	Symbol	Ctrl.	Buffer Type	Function
79	V _{DD}	I	—	Digital Core Power Supply (1.3V) This pin supplies also the main XTAL Oscillator/PLL (1.3V). A higher decoupling capacitor is therefore recommended to the VSS pin for better noise immunity.
83	V _{DDP3}	I	—	Digital I/O Power Supply (3.3V) This pin supplies also the main XTAL Oscillator/PLL (3.3V). A higher decoupling capacitor is therefore recommended to the VSS pin for better noise immunity.
44	V _{DDM}	I	—	ADC Power Supply (5.0V)
23	V _{DDP3}	I	—	Digital I/O Power Supply (3.3V)
10	V _{DD} /V _{DDSB}	I	—	Digital Core Power Supply (1.3V)
22	V _{DD}	I	—	Digital Core Power Supply (1.3V)
99	V _{DD}	I	—	Digital Core Power Supply (1.3V)
43	V _{SSM}	I	—	Analog Ground for VDDM
80	V _{SS}	I	—	Digital Ground

2.2.2 Pull-Up/Pull-Down Reset Behavior of the Pins

Table 2-38 List of Pull-Up/Pull-Down Reset Behavior of the Pins

Pins	$\overline{\text{PORST}} = 0$	$\overline{\text{PORST}} = 1$
all GPIOs	High-Z	
TDI, $\overline{\text{TESTMODE}}$	Pull-up	
$\overline{\text{PORST}}^{1)}$	Pull-down with I_{PORST} relevant	Pull-down with I_{PDLI} relevant
$\overline{\text{TRST}}$, TCK, TMS	Pull-down	
ESR0	The open-drain driver is used to drive low. ²⁾	Pull-up ³⁾
ESR1	Pull-up ³⁾	
P14.2, P14.3, P14.6	Pull-up	
P21.7 / TDO	Pull-up	High-Z/Pull-up ⁴⁾

1) Pull-down with I_{PORST} relevant is always activated when a primary supply monitor detects a violation.

2) Valid additionally after deactivation of $\overline{\text{PORST}}$ until the internal reset phase has finished. See the SCU chapter for details.

3) See the SCU_IOCR register description.

4) Depends on JTAG/DAP selection with $\overline{\text{TRST}}$.

2.3 PG-TQFP-100-23 Package Variant Pin Configuration of TC233x

Figure 2-1 is showing the TC233x pinout for the package variant: PG-TQFP-100-23.

Package and Pinning Definitions PG-TQFP-100-23 Package Variant Pin

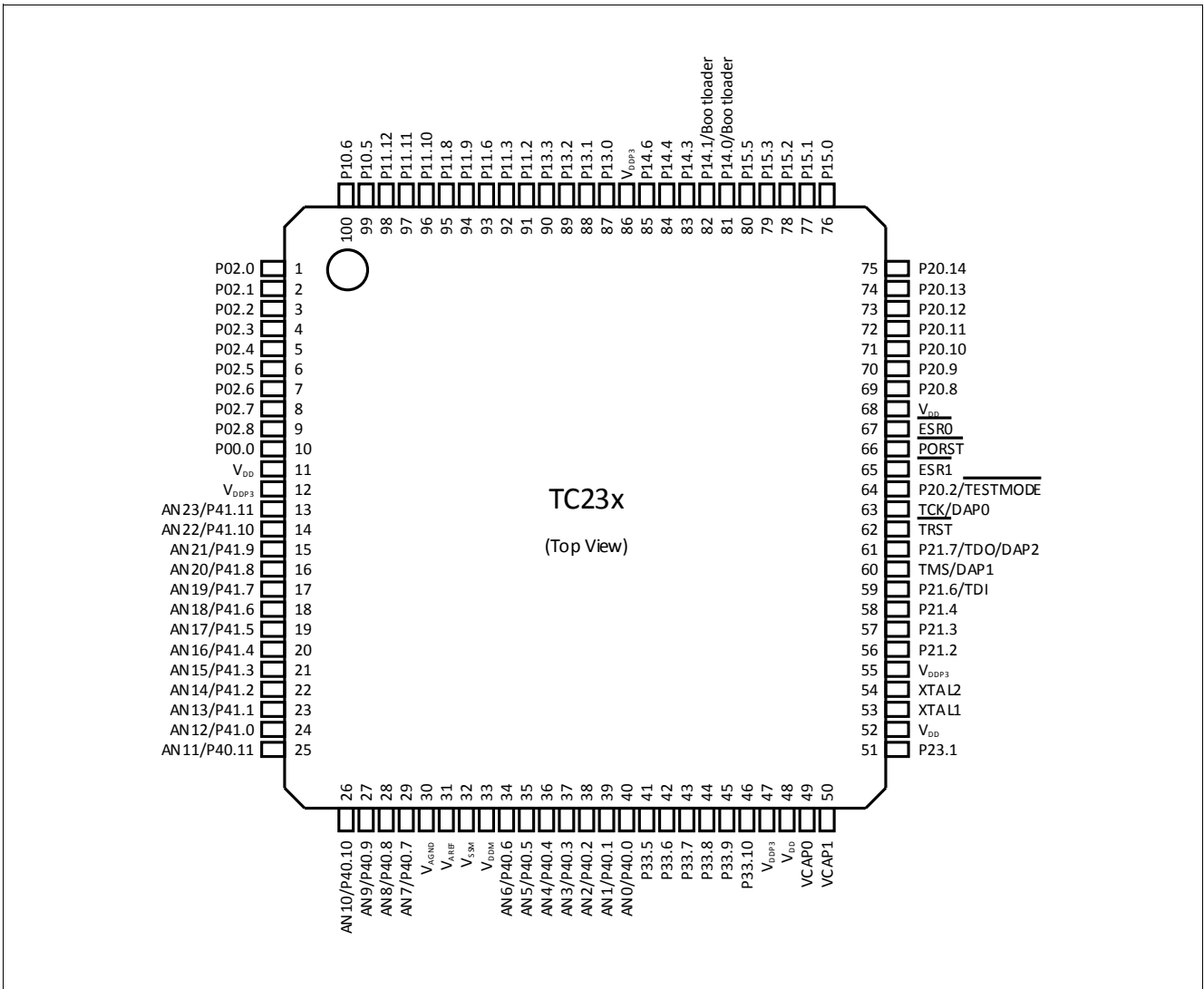

Figure 2-3 TC233x Pinout for the package variant PG-TQFP-100-23.

2.3.1 Port Functions and Pinning Tables

2.3.1.1 How to Read the Following Port Function Tables

Some hints for interpreting the following tables.

Column “Ctrl.”:

I = Input (for GPIO port Lines with IOCR bit field Selection PCx = 0XXX_B)

AI = Analog input

O = Output

O0 = Output with IOCR bit field selection PCx = 1X000_B

O1 = Output with IOCR bit field selection PCx = 1X001_B (ALT1)

O2 = Output with IOCR bit field selection PCx = 1X010_B (ALT2)

O3 = Output with IOCR bit field selection PCx = 1X011_B (ALT3)

O4 = Output with IOCR bit field selection PCx = 1X100_B (ALT4)

O5 = Output with IOCR bit field selection PCx = 1X101_B (ALT5)

O6 = Output with IOCR bit field selection PCx = 1X110_B (ALT6)

O7 = Output with IOCR bit field selection PCx = 1X111_B (ALT7)

Table 2-39 Example Port Table

Pin	Symbol	Ctrl.	Buffer Type	Function
10	Pxx.y	I	A1/HighZ/ VDDP3	General-purpose input
	TIMm_n			GTM_TIN
	TOMa_b	O1		GTM_TOUT
	TOMc_d			GTM_TOUT
	IOM_REFv_w			IOM reference input
	ASCLINz_RTS	O2		ASCLIN0 output (aka ARTSz)

To each input several functions can be connected. The peripherals' configuration defines if this input is used.

The port module (see corresponding chapter) decides which of the 8 output signals O0 to O7 drives the pad.

Some Ox rows list more than one function, e.g. several GTM_TOUT outputs and IOM reference inputs. The GTM module (see corresponding chapter) has its own sub-multiplexer structure that defines which of the GTM sub-units drives this signal. Additionally the IOM modules “listens” on these output signals (see IOM chapter).

Some pin symbol names were changed in this AURIX device compared to other AURIX devices to improve naming systematics. The previously used symbol name is documented in the “Function” column with the text “(aka ...)”¹⁾.

Column “Type”:

IN = Input only

A1 = Pad class A1 (3.3V)

A1+ = Pad class A1+ (3.3V)

S = ADC with digital input. Pad class D for analog input “AI”, pad class S for digital input “I”.

PU = with pull-up device connected during reset ($\overline{\text{PORST}} = 0$)

PD = with pull-down device connected during reset ($\overline{\text{PORST}} = 0$)

1) “aka” as abbreviation for “also known as”.

High-Z = High-Z during reset ($\overline{\text{PORST}} = 0$)

V_x = Supply (the Exposed Pad is also considered as VSS and shall be connected to ground)

2.3.1.2 Tables

Port function and pinning tables.

Table 2-40 Port 00 Functions

Pin	Symbol	Ctrl.	Buffer Type	Function
10	P00.0	I	A1 / HighZ / VDDP3	General-purpose input
	TIM0_0			GTM_TIN
	CCU61_CTRAPA			CCU61 input
	CCU60_T12HRE			CCU60 input
	P00.0	O0		General-purpose output
	TOM0_8	O1		GTM_TOUT
	TOM1_0		GTM_TOUT	
	TOM0_4		GTM_TOUT (= DTM1_OUT4)	
	TOM1_4		GTM_TOUT (= DTM5_OUT4)	
	IOM_REF0_9		IOM reference input	
	ASCLIN0_SCLK		O2	ASCLIN0 output (aka: ASCLK0)
	ASCLIN0_TX		O3	ASCLIN0 output (aka: ATX0)
	IOM_MON2_12			IOM monitor input
	IOM_REF2_12	IOM reference input		
	—	O4		Reserved
	CAN1_TXD	O5		CAN node 1 output (aka: TXDCAN1)
	IOM_MON2_6		IOM monitor input	
	IOM_REF2_6		IOM reference input	
	—	O6		Reserved
	CCU60_COUT63	O7		CCU60 output
IOM_MON1_6	IOM monitor input			
IOM_REF1_0	IOM reference input			

Table 2-41 Port 02 Functions

Pin	Symbol	Ctrl.	Buffer Type	Function
1	P02.0	I	A1+ / HighZ / VDDP3	General-purpose input
	TIM0_0			GTM_TIN
	SCU_REQ6			SCU input
	CCU60_CC60INA			CCU60 input
	CCU61_CC60INB			CCU61 input
	P02.0	O0		General-purpose output
	TOM0_8	O1		GTM_TOUT
	TOM1_8			GTM_TOUT
	TOM0_4			GTM_TOUT (= DTM1_OUT4)
	TOM1_4			GTM_TOUT (= DTM5_OUT4)
	IOM_REF0_0		IOM reference input	
	—	O2	Reserved	
	QSPI3_SLSO1	O3	QSPI3 output (aka: SLSO31)	
	—	O4	Reserved	
	CAN0_TXD	O5	CAN node 0 output (aka: TXDCAN0)	
	IOM_MON2_5		IOM monitor input	
	IOM_REF2_5		IOM reference input	
	ERAY0_TXDA	O6	ERAY0 output	
	CCU60_CC60	O7	CCU60 output	
	IOM_MON1_2		IOM monitor input	
IOM_REF1_6	IOM reference input			

Table 2-41 Port 02 Functions (cont'd)

Pin	Symbol	Ctrl.	Buffer Type	Function
2	P02.1	I	A1 / HighZ / VDDP3	General-purpose input
	TIM0_1			GTM_TIN
	CAN0_RXDA			CAN node 0 input (aka: RXDCAN0A)
	ERAY0_RXDA2			ERAY0 input
	SCU_REQ14			SCU input
	P02.1	O0		General-purpose output
	TOM0_9	O1		GTM_TOUT
	TOM1_9			GTM_TOUT
	TOM0_4N			GTM_TOUT (= DTM1_OUT4_N)
	TOM1_4N			GTM_TOUT (= DTM5_OUT4_N)
	IOM_REF0_1			IOM reference input
	—	O2		Reserved
	QSPI3_SLSO2	O3		QSPI3 output (aka: SLSO32)
	—	O4		Reserved
	—	O5		Reserved
	—	O6		Reserved
	CCU60_COUT60	O7		CCU60 output
	IOM_MON1_3			IOM monitor input
	IOM_REF1_3			IOM reference input

Table 2-41 Port 02 Functions (cont'd)

Pin	Symbol	Ctrl.	Buffer Type	Function
3	P02.2	I	A1+ / HighZ / VDDP3	General-purpose input
	TIM0_2			GTM_TIN
	CCU60_CC61INA			CCU60 input
	CCU61_CC61INB			CCU61 input
	P02.2	O0		General-purpose output
	TOM0_10	O1		GTM_TOUT
	TOM1_10			GTM_TOUT
	TOM0_5			GTM_TOUT (= DTM1_OUT5)
	TOM1_5			GTM_TOUT (= DTM5_OUT5)
	IOM_REF0_2			IOM reference input
	ASCLIN1_TX	O2	ASCLIN1 output (aka: ATX1)	
	IOM_MON2_13	O3	IOM monitor input	
	IOM_REF2_13		IOM reference input	
	QSPI3_SLSO3		QSPI3 output (aka: SLSO33)	
	—	O4	Reserved	
	CAN2_TXD	O5	CAN node 2 output (aka: TXDCAN2)	
	IOM_MON2_7	O6	IOM monitor input	
	IOM_REF2_7		IOM reference input	
	ERAY0_TXDB		ERAY0 output	
	CCU60_CC61	O7	CCU60 output	
IOM_MON1_1	O7	IOM monitor input		
IOM_REF1_5		IOM reference input		

Package and Pinning Definitions PG-TQFP-100-23 Package Variant Pin

Table 2-41 Port 02 Functions (cont'd)

Pin	Symbol	Ctrl.	Buffer Type	Function
4	P02.3	I	A1 / HighZ / VDDP3	General-purpose input
	TIM0_3			GTM_TIN
	ASCLIN1_RXG			ASCLIN1 input (aka: ARX1G)
	CAN2_RXDB			CAN node 2 input (aka: RXDCAN2B)
	ERAY0_RXDB2			ERAY0 input
	P02.3	O0		General-purpose output
	TOM0_11	O1		GTM_TOUT
	TOM1_11			GTM_TOUT
	TOM0_5N			GTM_TOUT (= DTM1_OUT5_N)
	TOM1_5N			GTM_TOUT (= DTM5_OUT5_N)
	IOM_REF0_3			IOM reference input
	—	O2		Reserved
	QSPI3_SLSO4	O3		QSPI3 output (aka: SLSO34)
	—	O4		Reserved
	—	O5		Reserved
	—	O6		Reserved
	CCU60_COUT61	O7		CCU60 output
	IOM_MON1_4			IOM monitor input
	IOM_REF1_2			IOM reference input

Table 2-41 Port 02 Functions (cont'd)

Pin	Symbol	Ctrl.	Buffer Type	Function
5	P02.4	I	A1+ / HighZ / VDDP3	General-purpose input
	TIM0_4			GTM_TIN
	QSPI3_SLSIA			QSPI3 input (aka: SLSI3A)
	CAN0_RXDD			CAN node 0 input (aka: RXDCAN0D)
	CCU60_CC62INA			CCU60 input
	CCU61_CC62INB			CCU61 input
	P02.4	O0		General-purpose output
	TOM0_12	O1		GTM_TOUT
	TOM1_12			GTM_TOUT
	TOM0_6			GTM_TOUT (= DTM1_OUT6)
	TOM1_6			GTM_TOUT (= DTM5_OUT6)
	IOM_REF0_4			IOM reference input
	—			O2
	QSPI3_SLSO0	O3		QSPI3 output (aka: SLSO30)
	—	O4		Reserved
	CAN10_TXD	O5		CAN1 node 0 output (aka: TXDCAN10)
	ERAY0_TXENA	O6		ERAY0 output
	CCU60_CC62	O7		CCU60 output
	IOM_MON1_0			IOM monitor input
	IOM_REF1_4			IOM reference input

Table 2-41 Port 02 Functions (cont'd)

Pin	Symbol	Ctrl.	Buffer Type	Function
6	P02.5	I	A1+ / HighZ / VDDP3	General-purpose input
	TIM0_5			GTM_TIN
	QSPI3_MRSTA			QSPI3 input (aka: MRST3A)
	SENT_SENT3C			SENT input
	P02.5	O0		General-purpose output
	TOM0_13	O1		GTM_TOUT
	TOM1_13			GTM_TOUT
	TOM0_6N			GTM_TOUT (= DTM1_OUT6_N)
	TOM1_6N			GTM_TOUT (= DTM5_OUT6_N)
	IOM_REF0_5	O2		IOM reference input
	CAN0_TXD			CAN node 0 output (aka: TXDCAN0)
	IOM_MON2_5			IOM monitor input
	IOM_REF2_5		IOM reference input	
	QSPI3_MRST	O3	QSPI3 output (aka: MRST3)	
	IOM_MON2_3		IOM monitor input	
	IOM_REF2_3		IOM reference input	
	—	O4	Reserved	
	CAN11_TXD	O5	CAN1 node 1 output (aka: TXDCAN11)	
	ERAY0_TXENB	O6	ERAY0 output	
	CCU60_COUT62	O7	CCU60 output	
IOM_MON1_5	IOM monitor input			
IOM_REF1_1	IOM reference input			

Table 2-41 Port 02 Functions (cont'd)

Pin	Symbol	Ctrl.	Buffer Type	Function
7	P02.6	I	A1 / HighZ / VDDP3	General-purpose input
	TIM0_6			GTM_TIN
	QSPI3_MTSRA			QSPI3 input (aka: MTSR3A)
	SENT_SENT2C			SENT input
	CCU60_CC60INC			CCU60 input
	CCU60_CCPOS0A			CCU60 input
	CCU61_T12HRB			CCU61 input
	GPT120_T3INA			GPT120 input
	CAN10_RXDF			CAN1 node 0 input (aka: RXDCAN10F)
	P02.6			O0
	TOM0_14	O1	GTM_TOUT	
	TOM1_14		GTM_TOUT	
	TOM0_7		GTM_TOUT (= DTM1_OUT7)	
	TOM1_7		GTM_TOUT (= DTM5_OUT7)	
	IOM_REF0_6		IOM reference input	
	—	O2	Reserved	
	QSPI3_MTSR	O3	QSPI3 output (aka: MTSR3)	
	—	O4	Reserved	
	VADC_EMUX00	O5	VADC output	
	—	O6	Reserved	
CCU60_CC60	O7	CCU60 output		
IOM_MON1_2		IOM monitor input		
IOM_REF1_6		IOM reference input		

Table 2-41 Port 02 Functions (cont'd)

Pin	Symbol	Ctrl.	Buffer Type	Function
8	P02.7	I	A1 / HighZ / VDDP3	General-purpose input
	TIM0_7			GTM_TIN
	QSPI3_SCLKA			QSPI3 input (aka: SCLK3A)
	SENT_SENT1C			SENT input
	CCU60_CC61INC			CCU60 input
	CCU60_CCPOS1A			CCU60 input
	CCU61_T13HRB			CCU61 input
	GPT120_T3EUDA			GPT120 input
	CAN11_RXDF			CAN1 node 1 input (aka: RXDCAN11F)
	PMU_FDEST			PMU input
	P02.7	O0	General-purpose output	
	TOM0_15	O1	GTM_TOUT	
	TOM1_15		GTM_TOUT	
	TOM0_7N		GTM_TOUT (= DTM1_OUT7_N)	
	TOM1_7N		GTM_TOUT (= DTM5_OUT7_N)	
	IOM_REF0_7		IOM reference input	
	—		O2	Reserved
	QSPI3_SCLK	O3	QSPI3 output (aka: SCLK3)	
	—	O4	Reserved	
	VADC_EMUX01	O5	VADC output	
	SENT_SPC1	O6	SENT output	
	CCU60_CC61	O7	CCU60 output	
	IOM_MON1_1		IOM monitor input	
	IOM_REF1_5		IOM reference input	

Table 2-41 Port 02 Functions (cont'd)

Pin	Symbol	Ctrl.	Buffer Type	Function
9	P02.8	I	A1 / HighZ / VDDP3	General-purpose input
	TIM0_0			GTM_TIN
	SENT_SENT0C			SENT input
	CCU60_CC62INC			CCU60 input
	CCU60_CCPOS2A			CCU60 input
	CCU61_T12HRC			CCU61 input
	CCU61_T13HRC			CCU61 input
	GPT120_T4INA			GPT120 input
	P02.8	O0	General-purpose output	
	TOM0_8	O1	GTM_TOUT	
	TOM1_0		GTM_TOUT	
	TOM0_4N		GTM_TOUT (= DTM1_OUT4_N)	
	TOM1_4N		GTM_TOUT (= DTM5_OUT4_N)	
	IOM_REF0_8		IOM reference input	
	QSPI3_SLSO5		O2	QSPI3 output (aka: SLSO35)
	—	O3	Reserved	
	—	O4	Reserved	
	VADC_EMUX02	O5	VADC output	
	—	O6	Reserved	
	CCU60_CC62	O7	CCU60 output	
IOM_MON1_0	IOM monitor input			
IOM_REF1_4	IOM reference input			

Table 2-42 Port 10 Functions

Pin	Symbol	Ctrl.	Buffer Type	Function
99	P10.5	I	A1 / HighZ / VDDP3	General-purpose input
	TIM0_2			GTM_TIN
	SCU_HWCFG4			SCU input
	CAN10_RXDA			CAN1 node 0 input (aka: RXDCAN10A)
	P10.5	O0		General-purpose output
	TOM0_2	O1		GTM_TOUT
	TOM1_10			GTM_TOUT
	IOM_REF2_9			IOM reference input
	—	O2		Reserved
	QSPI3_SLSO8	O3		QSPI3 output (aka: SLSO38)
	QSPI1_SLSO9	O4		QSPI1 output (aka: SLSO19)
	GPT120_T6OUT	O5		GPT120 output
	—	O6		Reserved
	—	O7		Reserved
100	P10.6	I	A1 / HighZ / VDDP3	General-purpose input
	TIM0_3			GTM_TIN
	QSPI3_MTSRB			QSPI3 input (aka: MTSR3B)
	SCU_HWCFG5			SCU input
	P10.6	O0		General-purpose output
	TOM0_3	O1		GTM_TOUT
	TOM1_11			GTM_TOUT
	IOM_REF2_10			IOM reference input
	—	O2		Reserved
	QSPI3_MTSR	O3		QSPI3 output (aka: MTSR3)
	GPT120_T3OUT	O4		GPT120 output
	CAN10_TXD	O5		CAN1 node 0 output (aka: TXDCAN10)
	QSPI1_MRST	O6		QSPI1 output (aka: MRST1)
	IOM_MON2_1			IOM monitor input
IOM_REF2_1	IOM reference input			
—	O7	Reserved		

Table 2-43 Port 11 Functions

Pin	Symbol	Ctrl.	Buffer Type	Function	
91	P11.2	I	A1+ / HighZ / VDDP3	General-purpose input	
	P11.2	O0		General-purpose output	
	TOM0_8	O1		GTM_TOUT	
	TOM1_1			GTM_TOUT	
	TOM0_4N			GTM_TOUT (= DTM1_OUT4_N)	
	TOM1_4N			GTM_TOUT (= DTM5_OUT4_N)	
	—			O2	Reserved
	QSPI0_SLSO5			O3	QSPI0 output (aka: SLSO05)
	QSPI1_SLSO5	O4		QSPI1 output (aka: SLSO15)	
	CCU61_COUT63	O5		CCU61 output	
	IOM_MON1_7			IOM monitor input	
	IOM_REF1_7			IOM reference input	
	—	O6		Reserved	
	CCU60_COUT63	O7		CCU60 output	
	IOM_MON1_6			IOM monitor input	
	IOM_REF1_0			IOM reference input	
	92	P11.3		I	A1+ / HighZ / VDDP3
QSPI1_MRSTB		QSPI1 input (aka: MRST1B)			
P11.3		O0	General-purpose output		
TOM0_10		O1	GTM_TOUT		
TOM1_2			GTM_TOUT		
TOM0_5			GTM_TOUT (= DTM1_OUT5)		
TOM1_5			GTM_TOUT (= DTM5_OUT5)		
—		O2	Reserved		
QSPI1_MRST		O3	QSPI1 output (aka: MRST1)		
IOM_MON2_1			IOM monitor input		
IOM_REF2_1			IOM reference input		
ERAY0_TXDA			O4	ERAY0 output	
CCU61_COUT62		O5	CCU61 output		
IOM_MON1_13			IOM monitor input		
IOM_REF1_8			IOM reference input		
—		O6	Reserved		
CCU60_COUT62		O7	CCU60 output		
IOM_MON1_5	IOM monitor input				
IOM_REF1_1	IOM reference input				

Package and Pinning Definitions PG-TQFP-100-23 Package Variant Pin

Table 2-43 Port 11 Functions (cont'd)

Pin	Symbol	Ctrl.	Buffer Type	Function
93	P11.6	I	A1+ / HighZ / VDDP3	General-purpose input
	QSPI1_SCLKB			QSPI1 input (aka: SCLK1B)
	P11.6	O0		General-purpose output
	TOM0_11	O1		GTM_TOUT
	TOM1_3			GTM_TOUT
	TOM0_5N			GTM_TOUT (= DTM1_OUT5_N)
	TOM1_5N			GTM_TOUT (= DTM5_OUT5_N)
	ERAY0_TXENB	O2		ERAY0 output
	QSPI1_SCLK	O3		QSPI1 output (aka: SCLK1)
	ERAY0_TXENA	O4		ERAY0 output
	CCU61_COUT61	O5		CCU61 output
	IOM_MON1_12			IOM monitor input
	IOM_REF1_9			IOM reference input
	—	O6		Reserved
	CCU60_COUT61	O7		CCU60 output
	IOM_MON1_4			IOM monitor input
IOM_REF1_2	IOM reference input			
95	P11.8	I	A1 / HighZ / VDDP3	General-purpose input
	QSPI1_MTSRC			QSPI1 input (aka: MTSR1C)
	P11.8	O0		General-purpose output
	TOM0_4	O1		GTM_TOUT (= DTM1_OUT4)
	TOM1_4			GTM_TOUT (= DTM5_OUT4)
	—	O2		Reserved
	QSPI1_SLSO10	O3		QSPI1 output (aka: SLSO110)
	QSPI1_MTSR	O4		QSPI1 output (aka: MTSR1)
	—	O5		Reserved
	—	O6		Reserved
	—	O7		Reserved

Package and Pinning Definitions PG-TQFP-100-23 Package Variant Pin

Table 2-43 Port 11 Functions (cont'd)

Pin	Symbol	Ctrl.	Buffer Type	Function
94	P11.9	I	A1+ / HighZ / VDDP3	General-purpose input
	QSPI1_MTSRB			QSPI1 input (aka: MTSR1B)
	ERAY0_RXDA1			ERAY0 input
	P11.9	O0		General-purpose output
	TOM0_12	O1		GTM_TOUT
	TOM1_4			GTM_TOUT (= DTM5_OUT4)
	TOM0_6			GTM_TOUT (= DTM1_OUT6)
	TOM1_6			GTM_TOUT (= DTM5_OUT6)
	—	O2		Reserved
	QSPI1_MTSR	O3		QSPI1 output (aka: MTSR1)
	—	O4		Reserved
	CCU61_COUT60	O5		CCU61 output
	IOM_MON1_11			IOM monitor input
	IOM_REF1_10			IOM reference input
	—	O6		Reserved
	CCU60_COUT60	O7		CCU60 output
	IOM_MON1_3			IOM monitor input
IOM_REF1_3	IOM reference input			
96	P11.10	I	A1+ / HighZ / VDDP3	General-purpose input
	ASCLIN1_RXE			ASCLIN1 input (aka: ARX1E)
	ERAY0_RXDB1			ERAY0 input
	SCU_REQ12			SCU input
	CAN12_RXDD			CAN1 node 2 input (aka: RXDCAN12D)
	P11.10	O0		General-purpose output
	TOM0_13	O1		GTM_TOUT
	TOM1_5			GTM_TOUT (= DTM5_OUT5)
	TOM0_6N			GTM_TOUT (= DTM1_OUT6_N)
	TOM1_6N			GTM_TOUT (= DTM5_OUT6_N)
	—	O2		Reserved
	QSPI0_SLSO3	O3		QSPI0 output (aka: SLSO03)
	QSPI1_SLSO3	O4		QSPI1 output (aka: SLSO13)
	CCU61_CC62	O5		CCU61 output
	IOM_MON1_10			IOM monitor input
	IOM_REF1_11			IOM reference input
	—	O6		Reserved
CCU60_CC62	O7	CCU60 output		
IOM_MON1_0		IOM monitor input		
IOM_REF1_4		IOM reference input		

Table 2-43 Port 11 Functions (cont'd)

Pin	Symbol	Ctrl.	Buffer Type	Function	
97	P11.11	I	A1+ / HighZ / VDDP3	General-purpose input	
	P11.11	O0		General-purpose output	
	TOM0_14	O1		GTM_TOUT	
	TOM1_6			GTM_TOUT (= DTM5_OUT6)	
	TOM0_7N			GTM_TOUT (= DTM1_OUT7_N)	
	TOM1_7N			GTM_TOUT (= DTM5_OUT7_N)	
	—			O2	Reserved
	QSPIO_SLSO4	O3		QSPIO output (aka: SLSO04)	
	QSPI1_SLSO4	O4		QSPI1 output (aka: SLSO14)	
	CCU61_CC61	O5		CCU61 output	
	IOM_MON1_9			IOM monitor input	
	IOM_REF1_12			IOM reference input	
	ERAY0_TXENB			O6	ERAY0 output
	CCU60_CC61			O7	CCU60 output
	IOM_MON1_1			IOM monitor input	
IOM_REF1_5	IOM reference input				
98	P11.12	I	A1+ / HighZ / VDDP3	General-purpose input	
	P11.12	O0		General-purpose output	
	TOM0_15	O1		GTM_TOUT	
	TOM1_7			GTM_TOUT (= DTM5_OUT7)	
	TOM0_7			GTM_TOUT (= DTM1_OUT7)	
	TOM1_7			GTM_TOUT (= DTM5_OUT7)	
	ASCLIN1_TX			O2	ASCLIN1 output (aka: ATX1)
	IOM_MON2_13	IOM monitor input			
	IOM_REF2_13	IOM reference input			
	GTM_CLK2	O3		GTM output	
	ERAY0_TXDB	O4		ERAY0 output	
	CCU61_CC60	O5		CCU61 output	
	IOM_MON1_8			IOM monitor input	
	IOM_REF1_13			IOM reference input	
	SCU_EXTCLK1			O6	SCU output
	CCU60_CC60	O7		CCU60 output	
	IOM_MON1_2			IOM monitor input	
IOM_REF1_6	IOM reference input				

Table 2-44 Port 13 Functions

Pin	Symbol	Ctrl.	Buffer Type	Function
87	P13.0	I	A1 / HighZ / VDDP3	General-purpose input
	CCU60_CTRAPA			CCU60 input
	GPT120_T6EUDB			GPT120 input
	P13.0	O0		General-purpose output
	TOM0_5	O1		GTM_TOUT (= DTM1_OUT5)
	TOM1_5			GTM_TOUT (= DTM5_OUT5)
	TOM0_6N			GTM_TOUT (= DTM1_OUT6_N)
	TOM1_6N			GTM_TOUT (= DTM5_OUT6_N)
	—	O2		Reserved
	QSPI2_SCLK	O3		QSPI2 output (aka: SCLK2)
	—	O4		Reserved
	—	O5		Reserved
	—	O6		Reserved
	CAN10_TXD	O7		CAN1 node 0 output (aka: TXDCAN10)
88	P13.1	I	A1 / HighZ / VDDP3	General-purpose input
	CCU60_CCPOS0C			CCU60 input
	GPT120_T3INB			GPT120 input
	CAN10_RXDB			CAN1 node 0 input (aka: RXDCAN10B)
	P13.1	O0		General-purpose output
	TOM0_6	O1		GTM_TOUT (= DTM1_OUT6)
	TOM1_6			GTM_TOUT (= DTM5_OUT6)
	TOM0_7			GTM_TOUT (= DTM1_OUT7)
	TOM1_7			GTM_TOUT (= DTM5_OUT7)
	—	O2		Reserved
	—	O3		Reserved
	—	O4		Reserved
	—	O5		Reserved
	—	O6		Reserved
—	O7	Reserved		

Table 2-44 Port 13 Functions (cont'd)

Pin	Symbol	Ctrl.	Buffer Type	Function
89	P13.2	I	A1 / HighZ / VDDP3	General-purpose input
	CCU60_CCPOS1C			CCU60 input
	GPT120_T3EUDB			GPT120 input
	GPT120_CAPINA			GPT120 input
	P13.2	O0		General-purpose output
	TOM0_7	O1		GTM_TOUT (= DTM1_OUT7)
	TOM1_7			GTM_TOUT (= DTM5_OUT7)
	TOM0_7N			GTM_TOUT (= DTM1_OUT7_N)
	TOM1_7N			GTM_TOUT (= DTM5_OUT7_N)
	CAN11_TXD	O2		CAN1 node 1 output (aka: TXDCAN11)
	—	O3		Reserved
	—	O4		Reserved
	—	O5		Reserved
	—	O6		Reserved
—	O7	Reserved		
90	P13.3	I	A1 / HighZ / VDDP3	General-purpose input
	CCU60_CCPOS2C			CCU60 input
	GPT120_T4INB			GPT120 input
	CAN11_RXDB			CAN1 node 1 input (aka: RXDCAN11B)
	P13.3	O0		General-purpose output
	TOM0_8	O1		GTM_TOUT
	TOM1_0			GTM_TOUT
	TOM0_4			GTM_TOUT (= DTM1_OUT4)
	TOM1_4			GTM_TOUT (= DTM5_OUT4)
	—	O2		Reserved
	QSPI2_MTSR	O3		QSPI2 output (aka: MTSR2)
	—	O4		Reserved
	—	O5		Reserved
	—	O6		Reserved
—	O7	Reserved		

Table 2-45 Port 14 Functions

Pin	Symbol	Ctrl.	Buffer Type	Function
81	P14.0	I	A1+ / HighZ / VDDP3	General-purpose input
	TIM0_3			GTM_TIN
	P14.0	O0		General-purpose output
	TOM0_3	O1		GTM_TOUT
	TOM1_3			GTM_TOUT
	TOM0_6			GTM_TOUT (= DTM1_OUT6)
	TOM1_6			GTM_TOUT (= DTM5_OUT6)
	ASCLIN0_TX	O2		ASCLIN0 output (aka: ATX0)
	IOM_MON2_12			IOM monitor input
	IOM_REF2_12			IOM reference input
	ERAY0_TXDA	O3		ERAY0 output
	ERAY0_TXDB	O4		ERAY0 output
	CAN1_TXD	O5		CAN node 1 output (aka: TXDCAN1)
	IOM_MON2_6			IOM monitor input
	IOM_REF2_6			IOM reference input
	ASCLIN0_SCLK	O6		ASCLIN0 output (aka: ASCLK0)
	CCU60_COUT62	O7		CCU60 output
	IOM_MON1_5			IOM monitor input
	IOM_REF1_1			IOM reference input

Package and Pinning Definitions PG-TQFP-100-23 Package Variant Pin

Table 2-45 Port 14 Functions (cont'd)

Pin	Symbol	Ctrl.	Buffer Type	Function
82	P14.1	I	A1+ / HighZ / VDDP3	General-purpose input
	TIM0_4			GTM_TIN
	ASCLIN0_RXA			ASCLIN0 input (aka: ARX0A)
	CAN1_RXDB			CAN node 1 input (aka: RXDCAN1B)
	ERAY0_RXDA3			ERAY0 input
	SCU_REQ15			SCU input
	ERAY0_RXDB3			ERAY0 input
	SCU_EVRWUPA	AI		SCU input
	P14.1	O0		General-purpose output
	TOM0_4	O1		GTM_TOUT (= DTM1_OUT4)
	TOM1_4			GTM_TOUT (= DTM5_OUT4)
	TOM0_7			GTM_TOUT (= DTM1_OUT7)
	TOM1_7			GTM_TOUT (= DTM5_OUT7)
	IOM_REF1_14		IOM reference input	
	ASCLIN0_TX	O2	ASCLIN0 output (aka: ATX0)	
	IOM_MON2_12		IOM monitor input	
	IOM_REF2_12		IOM reference input	
	—	O3	Reserved	
	—	O4	Reserved	
	—	O5	Reserved	
—	O6	Reserved		
CCU60_COUT63	O7	CCU60 output		
IOM_MON1_6		IOM monitor input		
IOM_REF1_0		IOM reference input		
83	P14.3	I	A1 / PU / VDDP3	General-purpose input
	TIM0_6			GTM_TIN
	SCU_REQ10			SCU input
	SCU_HWCFG3_BMI			SCU input
	P14.3	O0	General-purpose output	
	TOM0_6	O1	GTM_TOUT (= DTM1_OUT6)	
	TOM1_6		GTM_TOUT (= DTM5_OUT6)	
	IOM_REF2_4		IOM reference input	
	—	O2	Reserved	
	QSPI2_SLSO3	O3	QSPI2 output (aka: SLSO23)	
	ASCLIN1_SLSO	O4	ASCLIN1 output (aka: ASLSO1)	
	—	O5	Reserved	
	—	O6	Reserved	
	—	O7	Reserved	

Table 2-45 Port 14 Functions (cont'd)

Pin	Symbol	Ctrl.	Buffer Type	Function
84	P14.4	I	A1+ / HighZ / VDDP3	General-purpose input
	TIM0_7			GTM_TIN
	P14.4	O0		General-purpose output
	TOM0_7	O1		GTM_TOUT (= DTM1_OUT7)
	TOM1_7			GTM_TOUT (= DTM5_OUT7)
	TOM0_7N			GTM_TOUT (= DTM1_OUT7_N)
	TOM1_7N			GTM_TOUT (= DTM5_OUT7_N)
	IOM_REF2_8			IOM reference input
	—			O2
	—	O3		Reserved
	—	O4		Reserved
	—	O5		Reserved
	—	O6		Reserved
	—	O7		Reserved
85	P14.6	I	A1+ / PU / VDDP3	General-purpose input
	TIM0_1			GTM_TIN
	SCU_HWCFG0_DCLDO			SCU input
	QSPI0_MRSTD			QSPI0 input (aka: MRSTD)
	P14.6	O0		General-purpose output
	TOM0_1	O1		GTM_TOUT
	TOM1_1			GTM_TOUT
	IOM_REF2_14			IOM reference input
	—	O2		Reserved
	QSPI2_SLSO2	O3		QSPI2 output (aka: SLSO2)
	—	O4		Reserved
	—	O5		Reserved
	ERAY0_TXENB	O6		ERAY0 output
	—	O7		Reserved

Table 2-46 Port 15 Functions

Pin	Symbol	Ctrl.	Buffer Type	Function
76	P15.0	I	A1 / HighZ / VDDP3	General-purpose input
	P15.0	O0		General-purpose output
	TOM1_3	O1		GTM_TOUT
	TOM0_11			GTM_TOUT
	TOM0_7N			GTM_TOUT (= DTM1_OUT7_N)
	TOM1_7N			GTM_TOUT (= DTM5_OUT7_N)
	ASCLIN1_TX	O2		ASCLIN1 output (aka: ATX1)
	IOM_MON2_13			IOM monitor input
	IOM_REF2_13			IOM reference input
	QSPIO_SLSO13	O3		QSPIO output (aka: SLSO013)
	—	O4		Reserved
	CAN2_TXD	O5		CAN node 2 output (aka: TXDCAN2)
	IOM_MON2_7			IOM monitor input
	IOM_REF2_7			IOM reference input
	ASCLIN1_SCLK	O6		ASCLIN1 output (aka: ASCLK1)
	—	O7		Reserved
77	P15.1	I	A1 / HighZ / VDDP3	General-purpose input
	ASCLIN1_RXA			ASCLIN1 input (aka: ARX1A)
	QSPI2_SLSIB			QSPI2 input (aka: SLSI2B)
	CAN2_RXDA			CAN node 2 input (aka: RXDCAN2A)
	SCU_REQ16			SCU input
	SCU_EVRWUPB	AI		SCU input
	P15.1	O0		General-purpose output
	TOM1_4	O1		GTM_TOUT (= DTM5_OUT4)
	TOM0_12			GTM_TOUT
	TOM0_4			GTM_TOUT (= DTM1_OUT4)
	TOM1_4			GTM_TOUT (= DTM5_OUT4)
	ASCLIN1_TX	O2		ASCLIN1 output (aka: ATX1)
	IOM_MON2_13			IOM monitor input
	IOM_REF2_13			IOM reference input
	QSPI2_SLSO5	O3		QSPI2 output (aka: SLSO25)
	—	O4		Reserved
	—	O5		Reserved
	—	O6		Reserved
	—	O7		Reserved

Package and Pinning Definitions PG-TQFP-100-23 Package Variant Pin

Table 2-46 Port 15 Functions (cont'd)

Pin	Symbol	Ctrl.	Buffer Type	Function	
78	P15.2	I	A1 / HighZ / VDDP3	General-purpose input	
	QSPI2_MRSTE			QSPI2 input (aka: MRST2E)	
	QSPI2_SLSIA			QSPI2 input (aka: SLSI2A)	
	QSPI2_HSICINA			QSPI2 input (aka: HSIC2INA)	
	P15.2	O0	A1 / HighZ / VDDP3	General-purpose output	
	TOM1_5	O1		GTM_TOUT (= DTM5_OUT5)	
	TOM0_13	O1		GTM_TOUT	
	TOM0_4N			GTM_TOUT (= DTM1_OUT4_N)	
	TOM1_4N			GTM_TOUT (= DTM5_OUT4_N)	
	ASCLIN0_TX			O2	ASCLIN0 output (aka: ATX0)
	IOM_MON2_12	O2		IOM monitor input	
	IOM_REF2_12			IOM reference input	
	QSPI2_SLSO0	O3		QSPI2 output (aka: SLSO20)	
	—	O4		Reserved	
	CAN1_TXD	O5		CAN node 1 output (aka: TXDCAN1)	
	IOM_MON2_6	O5		IOM monitor input	
	IOM_REF2_6			IOM reference input	
	ASCLIN0_SCLK	O6		ASCLIN0 output (aka: ASCLK0)	
	—	O7		Reserved	
	79	P15.3		I	A1 / HighZ / VDDP3
ASCLIN0_RXB		ASCLIN0 input (aka: ARX0B)			
QSPI2_SCLKA		QSPI2 input (aka: SCLK2A)			
QSPI2_HSICINB		QSPI2 input (aka: HSIC2INB)			
CAN1_RXDA		O0		A1 / HighZ / VDDP3	CAN node 1 input (aka: RXDCAN1A)
P15.3			General-purpose output		
TOM1_6			O1		GTM_TOUT (= DTM5_OUT6)
TOM0_14			O1		GTM_TOUT
TOM0_5		GTM_TOUT (= DTM1_OUT5)			
TOM1_5		GTM_TOUT (= DTM5_OUT5)			
ASCLIN0_TX		O2			ASCLIN0 output (aka: ATX0)
IOM_MON2_12		O2	IOM monitor input		
IOM_REF2_12			IOM reference input		
QSPI2_SCLK		O3	QSPI2 output (aka: SCLK2)		
—		O4	Reserved		
—		O5	Reserved		
—		O6	Reserved		
—		O7	Reserved		

Package and Pinning Definitions PG-TQFP-100-23 Package Variant Pin

Table 2-46 Port 15 Functions (cont'd)

Pin	Symbol	Ctrl.	Buffer Type	Function
80	P15.5	I	A1 / HighZ / VDDP3	General-purpose input
	ASCLIN1_RXB			ASCLIN1 input (aka: ARX1B)
	QSPI2_MTSRA			QSPI2 input (aka: MTSR2A)
	SCU_REQ13			SCU input
	P15.5	O0		General-purpose output
	TOM0_0	O1		GTM_TOUT
	TOM1_0			GTM_TOUT
	TOM0_5N			GTM_TOUT (= DTM1_OUT5_N)
	TOM1_5N			GTM_TOUT (= DTM5_OUT5_N)
	ASCLIN1_TX	O2		ASCLIN1 output (aka: ATX1)
	IOM_MON2_13			IOM monitor input
	IOM_REF2_13			IOM reference input
	QSPI2_MTSR	O3		QSPI2 output (aka: MTSR2)
	—	O4		Reserved
	—	O5		Reserved
	—	O6		Reserved
	CCU60_CC61	O7		CCU60 output
	IOM_MON1_1			IOM monitor input
	IOM_REF1_5			IOM reference input

Table 2-47 Port 20 Functions

Pin	Symbol	Ctrl.	Buffer Type	Function
64	P20.2	I	Input Only / PU / VDDP3	General-purpose input
	TESTMODE			Factory Test Mode Enable

Package and Pinning Definitions PG-TQFP-100-23 Package Variant Pin

Table 2-47 Port 20 Functions (cont'd)

Pin	Symbol	Ctrl.	Buffer Type	Function
69	P20.8	I	A1 / HighZ / VDDP3	General-purpose input
	TIM0_7			GTM_TIN
	P20.8	O0		General-purpose output
	TOM1_7	O1		GTM_TOUT (= DTM5_OUT7)
	TOM0_7			GTM_TOUT (= DTM1_OUT7)
	TOM0_4			GTM_TOUT (= DTM1_OUT4)
	TOM1_4			GTM_TOUT (= DTM5_OUT4)
	IOM_MON2_8			IOM monitor input
	ASCLIN1_SLSO	O2		ASCLIN1 output (aka: ASLSO1)
	QSPI0_SLSO0	O3		QSPI0 output (aka: SLSO00)
	QSPI1_SLSO0	O4		QSPI1 output (aka: SLSO10)
	CAN0_TXD	O5		CAN node 0 output (aka: TXDCAN0)
	IOM_MON2_5			IOM monitor input
	IOM_REF2_5			IOM reference input
	SCU_WDT0LCK	O6		SCU output
	CCU61_CC60	O7		CCU61 output
	IOM_MON1_8			IOM monitor input
IOM_REF1_13	IOM reference input			
70	P20.9	I	A1 / HighZ / VDDP3	General-purpose input
	ASCLIN1_RXC			ASCLIN1 input (aka: ARX1C)
	QSPI0_SLSIB			QSPI0 input (aka: SLSI0B)
	SCU_REQ11			SCU input
	CAN12_RXDE			CAN1 node 2 input (aka: RXDCAN12E)
	P20.9	O0		General-purpose output
	TOM1_13	O1		GTM_TOUT
	TOM0_13			GTM_TOUT
	TOM0_4N			GTM_TOUT (= DTM1_OUT4_N)
	TOM1_4N			GTM_TOUT (= DTM5_OUT4_N)
	IOM_MON2_11			IOM monitor input
	—	O2		Reserved
	QSPI0_SLSO1	O3		QSPI0 output (aka: SLSO01)
	QSPI1_SLSO1	O4		QSPI1 output (aka: SLSO11)
	—	O5		Reserved
	SCU_WDTSLCK	O6		SCU output
	CCU61_CC61	O7		CCU61 output
IOM_MON1_9	IOM monitor input			
IOM_REF1_12	IOM reference input			

Table 2-47 Port 20 Functions (cont'd)

Pin	Symbol	Ctrl.	Buffer Type	Function
71	P20.10	I	A1 / HighZ / VDDP3	General-purpose input
	P20.10	O0		General-purpose output
	TOM1_14	O1		GTM_TOUT
	TOM0_14			GTM_TOUT
	TOM0_5			GTM_TOUT (= DTM1_OUT5)
	TOM1_5			GTM_TOUT (= DTM5_OUT5)
	IOM_MON2_14			IOM monitor input
	ASCLIN1_TX			O2
	IOM_MON2_13	O2		IOM monitor input
	IOM_REF2_13			IOM reference input
	QSPI0_SLSO6			O3
	QSPI2_SLSO7	O4		QSPI2 output (aka: SLSO27)
	CAN12_TXD	O5		CAN1 node 2 output (aka: TXDCAN12)
	ASCLIN1_SCLK	O6		ASCLIN1 output (aka: ASCLK1)
	CCU61_CC62	O7		CCU61 output
	IOM_MON1_10	O7		IOM monitor input
	IOM_REF1_11			IOM reference input
72	P20.11	I	A1+ / HighZ / VDDP3	General-purpose input
	QSPI0_SCLKA	O0		QSPI0 input (aka: SCLK0A)
	P20.11			General-purpose output
	TOM1_15	O1		GTM_TOUT
	TOM0_15			GTM_TOUT
	TOM0_5N			GTM_TOUT (= DTM1_OUT5_N)
	TOM1_5N			GTM_TOUT (= DTM5_OUT5_N)
	IOM_MON2_15			IOM monitor input
	—			O2
	QSPI0_SCLK	O3		QSPI0 output (aka: SCLK0)
	—	O4		Reserved
	CAN11_TXD	O5		CAN1 node 1 output (aka: TXDCAN11)
	—	O6		Reserved
	CCU61_COUT60	O7		CCU61 output
	IOM_MON1_11			IOM monitor input
	IOM_REF1_10			IOM reference input

Package and Pinning Definitions PG-TQFP-100-23 Package Variant Pin

Table 2-47 Port 20 Functions (cont'd)

Pin	Symbol	Ctrl.	Buffer Type	Function
73	P20.12	I	A1 / HighZ / VDDP3	General-purpose input
	QSPI0_MRSTA			QSPI0 input (aka: MRST0A)
	CAN11_RXDH			CAN1 node 1 input (aka: RXDCAN11H)
	IOM_PIN13			IOM pad input
	P20.12	O0		General-purpose output
	TOM1_0	O1		GTM_TOUT
	TOM0_8		GTM_TOUT	
	TOM0_6		GTM_TOUT (= DTM1_OUT6)	
	TOM1_6		GTM_TOUT (= DTM5_OUT6)	
	IOM_MON0_13		IOM monitor input	
	—		O2	
	QSPI0_MRST	O3		QSPI0 output (aka: MRST0)
	IOM_MON2_0		IOM monitor input	
	IOM_REF2_0		IOM reference input	
	QSPI0_MTSR	O4		QSPI0 output (aka: MTSR0)
	—	O5		Reserved
	—	O6		Reserved
	CCU61_COUT61	O7		CCU61 output
	IOM_MON1_12		IOM monitor input	
	IOM_REF1_9		IOM reference input	
74	P20.13	I	A1+ / HighZ / VDDP3	General-purpose input
	QSPI0_SLSIA			QSPI0 input (aka: SLSI0A)
	CAN12_RXDH			CAN1 node 2 input (aka: RXDCAN12H)
	IOM_PIN14			IOM pad input
	P20.13	O0		General-purpose output
	TOM1_1	O1		GTM_TOUT
	TOM0_9		GTM_TOUT	
	TOM0_6N		GTM_TOUT (= DTM1_OUT6_N)	
	TOM1_6N		GTM_TOUT (= DTM5_OUT6_N)	
	IOM_MON0_14		IOM monitor input	
	—		O2	
	QSPI0_SLSO2	O3		QSPI0 output (aka: SLSO02)
	QSPI1_SLSO2	O4		QSPI1 output (aka: SLSO12)
	QSPI0_SCLK	O5		QSPI0 output (aka: SCLK0)
	—	O6		Reserved
	CCU61_COUT62	O7		CCU61 output
	IOM_MON1_13		IOM monitor input	
	IOM_REF1_8		IOM reference input	

Table 2-47 Port 20 Functions (cont'd)

Pin	Symbol	Ctrl.	Buffer Type	Function
75	P20.14	I	A1+ / HighZ / VDDP3	General-purpose input
	QSPI0_MTSRA			QSPI0 input (aka: MTSR0A)
	IOM_PIN15			IOM pad input
	P20.14	O0		General-purpose output
	TOM1_2	O1		GTM_TOUT
	TOM0_10			GTM_TOUT
	TOM0_7			GTM_TOUT (= DTM1_OUT7)
	TOM1_7			GTM_TOUT (= DTM5_OUT7)
	IOM_MON0_15			IOM monitor input
	—	O2		Reserved
	QSPI0_MTSR	O3		QSPI0 output (aka: MTSR0)
	—	O4		Reserved
	CAN12_TXD	O5		CAN1 node 2 output (aka: TXDCAN12)
	—	O6		Reserved
	—	O7		Reserved

Table 2-48 Port 21 Functions

Pin	Symbol	Ctrl.	Buffer Type	Function
56	P21.2	I	A1 / HighZ / VDDP3	General-purpose input
	TIM0_0			GTM_TIN
	SCU_EMGSTOPB			SCU input
	P21.2	O0		General-purpose output
	TOM0_0	O1		GTM_TOUT
	TOM1_0			GTM_TOUT
	TOM0_4			GTM_TOUT (= DTM1_OUT4)
	TOM1_4			GTM_TOUT (= DTM5_OUT4)
	—	O2		Reserved
	—	O3		Reserved
	—	O4		Reserved
	—	O5		Reserved
	—	O6		Reserved
—	O7	Reserved		

Table 2-48 Port 21 Functions (cont'd)

Pin	Symbol	Ctrl.	Buffer Type	Function	
57	P21.3	I	A1 / HighZ / VDDP3	General-purpose input	
	TIM0_1			GTM_TIN	
	P21.3	O0		General-purpose output	
	TOM0_1	O1		GTM_TOUT	
	TOM1_1			GTM_TOUT	
	TOM0_4N			GTM_TOUT (= DTM1_OUT4_N)	
	TOM1_4N			GTM_TOUT (= DTM5_OUT4_N)	
	—			O2	Reserved
	—			O3	Reserved
	—	O4		Reserved	
	—	O5		Reserved	
	—	O6		Reserved	
	—	O7		Reserved	
	58	P21.4		I	A1 / HighZ / VDDP3
TIM0_2		GTM_TIN			
P21.4		O0	General-purpose output		
TOM0_2		O1	GTM_TOUT		
TOM1_2			GTM_TOUT		
TOM0_5			GTM_TOUT (= DTM1_OUT5)		
TOM1_5			GTM_TOUT (= DTM5_OUT5)		
—			O2	Reserved	
—			O3	Reserved	
—		O4	Reserved		
—		O5	Reserved		
—		O6	Reserved		
—		O7	Reserved		

Table 2-48 Port 21 Functions (cont'd)

Pin	Symbol	Ctrl.	Buffer Type	Function
59	P21.6	I	A1 / PU / VDDP3	General-purpose input
	TIM0_4			GTM_TIN
	TDI			OCDS input
	OCDS_TGI2			OCDS input
	GPT120_T5EUDA			GPT120 input
	P21.6	O0		General-purpose output
	TOM0_4	O1		GTM_TOUT (= DTM1_OUT4)
	TOM1_4			GTM_TOUT (= DTM5_OUT4)
	—	O2		Reserved
	—	O3		Reserved
	—	O4		Reserved
	—	O5		Reserved
	—	O6		Reserved
	GPT120_T3OUT	O7		GPT120 output
	OCDS_TGO2	O		OCDS
61	P21.7	I	A1+ / PU / VDDP3	General-purpose input
	TIM0_5			GTM_TIN
	OCDS_DAP2			OCDS input
	OCDS_TGI3			OCDS input
	GPT120_T5INA			GPT120 input
	P21.7	O0		General-purpose output
	TOM0_5	O1		GTM_TOUT (= DTM1_OUT5)
	TOM1_5			GTM_TOUT (= DTM5_OUT5)
	—	O2		Reserved
	—	O3		Reserved
	—	O4		Reserved
	—	O5		Reserved
	—	O6		Reserved
	GPT120_T6OUT	O7		GPT120 output
	OCDS_TGO3	O		OCDS
OCDS_DAP2	O	OCDS Output		
TDO	O	JTAG Output		

Table 2-49 Port 23 Functions

Pin	Symbol	Ctrl.	Buffer Type	Function
51	P23.1	I	A1+ / HighZ / VDDP3	General-purpose input
	TIM0_6			GTM_TIN
	P23.1	O0		General-purpose output
	TOM0_6	O1		GTM_TOUT (= DTM1_OUT6)
	TOM0_15			GTM_TOUT
	ASCLIN1_RTS	O2		ASCLIN1 output (aka: ARTS1)
	QSPI3_SLSO13	O3		QSPI3 output (aka: SLSO313)
	GTM_CLK0	O4		GTM output
	SCU_EXTCLK1	O5		SCU output
	SCU_EXTCLK0	O6		SCU output
	—	O7		Reserved

Table 2-50 Port 33 Functions

Pin	Symbol	Ctrl.	Buffer Type	Function
41	P33.5	I	A1 / HighZ / VDDP3	General-purpose input
	TIM0_1			GTM_TIN
	CCU61_CCPOS2C			CCU61 input
	GPT120_T4EUDB			GPT120 input
	IOM_PIN5			IOM pad input
	P33.5	O0		General-purpose output
	TOM0_1	O1		GTM_TOUT
	TOM1_1			GTM_TOUT
	TOM0_5			GTM_TOUT (= DTM1_OUT5)
	TOM1_5			GTM_TOUT (= DTM5_OUT5)
	IOM_MON0_5			IOM monitor input
	QSPI0_SLSO7	O2		QSPI0 output (aka: SLSO07)
	QSPI1_SLSO7	O3		QSPI1 output (aka: SLSO17)
	—	O4		Reserved
	VADC_EMUX11	O5		VADC output
	VADC_G0BFL1	O6		VADC output
	CCU61_CC60	O7		CCU61 output
	IOM_MON1_8			IOM monitor input
	IOM_REF1_13			IOM reference input

Table 2-50 Port 33 Functions (cont'd)

Pin	Symbol	Ctrl.	Buffer Type	Function
42	P33.6	I	A1 / HighZ / VDDP3	General-purpose input
	TIM0_2			GTM_TIN
	ASCLIN1_RXF			ASCLIN1 input (aka: ARX1F)
	CCU61_CCPOS1C			CCU61 input
	GPT120_T2EUDB			GPT120 input
	CAN10_RXDH			CAN1 node 0 input (aka: RXDCAN10H)
	IOM_PIN6			IOM pad input
	P33.6	O0	General-purpose output	
	TOM0_2	O1	GTM_TOUT	
	TOM1_2		GTM_TOUT	
	TOM0_5N		GTM_TOUT (= DTM1_OUT5_N)	
	TOM1_5N		GTM_TOUT (= DTM5_OUT5_N)	
	IOM_MON0_6		IOM monitor input	
	—		O2	Reserved
	—	O3	Reserved	
	ASCLIN1_TX	O4	ASCLIN1 output (aka: ATX1)	
	IOM_MON2_13	O4	IOM monitor input	
	IOM_REF2_13		IOM reference input	
	VADC_EMUX10		VADC output	
	VADC_G0BFL2	O6	VADC output	
	CCU61_CC61	O7	CCU61 output	
	IOM_MON1_9	O7	IOM monitor input	
	IOM_REF1_12		IOM reference input	
	HSM_HSM1		O	HSM output

Table 2-50 Port 33 Functions (cont'd)

Pin	Symbol	Ctrl.	Buffer Type	Function
43	P33.7	I	A1+ / HighZ / VDDP3	General-purpose input
	TIM0_3			GTM_TIN
	CAN0_RXDE			CAN node 0 input (aka: RXDCAN0E)
	SCU_REQ8			SCU input
	CCU61_CCPOS0C			CCU61 input
	GPT120_T2INB			GPT120 input
	IOM_PIN7			IOM pad input
	P33.7	O0		General-purpose output
	TOM0_3	O1		GTM_TOUT
	TOM1_3			GTM_TOUT
	TOM0_6			GTM_TOUT (= DTM1_OUT6)
	TOM1_6			GTM_TOUT (= DTM5_OUT6)
	IOM_MON0_7			IOM monitor input
	—	O2		Reserved
	QSPI3_SLSO7	O3		QSPI3 output (aka: SLSO37)
	—	O4		Reserved
	CAN10_TXD	O5		CAN1 node 0 output (aka: TXDCAN10)
	VADC_G0BFL3	O6		VADC output
	CCU61_COUT60	O7		CCU61 output
	IOM_MON1_11			IOM monitor input
IOM_REF1_10	IOM reference input			
HSM_HSM2	O	HSM output		

Table 2-50 Port 33 Functions (cont'd)

Pin	Symbol	Ctrl.	Buffer Type	Function
44	P33.8	I	A1+ / HighZ / VDDP3	General-purpose input
	TIM0_4			GTM_TIN
	SCU_EMGSTOPA			SCU input
	IOM_PIN8			IOM pad input
	P33.8	O0		General-purpose output
	TOM0_4	O1		GTM_TOUT (= DTM1_OUT4)
	TOM1_4			GTM_TOUT (= DTM5_OUT4)
	TOM0_6N			GTM_TOUT (= DTM1_OUT6_N)
	TOM1_6N			GTM_TOUT (= DTM5_OUT6_N)
	IOM_MON0_8	O2		IOM monitor input
	—			Reserved
	QSPI3_SLSO2	O3		QSPI3 output (aka: SLSO32)
	—	O4		Reserved
	CAN0_TXD	O5		CAN node 0 output (aka: TXDCAN0)
	IOM_MON2_5			IOM monitor input
	IOM_REF2_5			IOM reference input
	—	O6		Reserved
	CCU61_COUT62	O7		CCU61 output
	IOM_MON1_13			IOM monitor input
	IOM_REF1_8			IOM reference input
SMU_FSP	O	SMU		

Package and Pinning Definitions PG-TQFP-100-23 Package Variant Pin

Table 2-50 Port 33 Functions (cont'd)

Pin	Symbol	Ctrl.	Buffer Type	Function	
45	P33.9	I	A1 / HighZ / VDDP3	General-purpose input	
	TIM0_1			GTM_TIN	
	QSPI3_HSI3INA			QSPI3 input (aka: HSI3INA)	
	IOM_PIN9			IOM pad input	
	P33.9	O0		General-purpose output	
	TOM0_1	O1		GTM_TOUT	
	TOM1_1			GTM_TOUT	
	TOM0_7			GTM_TOUT (= DTM1_OUT7)	
	TOM1_7			GTM_TOUT (= DTM5_OUT7)	
	IOM_MON0_9			IOM monitor input	
	—			O2	Reserved
	QSPI3_SLSO1			O3	QSPI3 output (aka: SLSO31)
	—	O4		Reserved	
	—	O5		Reserved	
	—	O6		Reserved	
	CCU61_CC62	O7		CCU61 output	
	IOM_MON1_10			IOM monitor input	
	IOM_REF1_11			IOM reference input	
46	P33.10	I	A1+ / HighZ / VDDP3	General-purpose input	
	TIM0_0			GTM_TIN	
	QSPI3_SLSIC			QSPI3 input (aka: SLSI3C)	
	QSPI3_HSI3INB			QSPI3 input (aka: HSI3INB)	
	IOM_PIN10	IOM pad input			
	P33.10	O0		General-purpose output	
	TOM0_0	O1		GTM_TOUT	
	TOM1_0			GTM_TOUT	
	TOM0_7N			GTM_TOUT (= DTM1_OUT7_N)	
	TOM1_7N			GTM_TOUT (= DTM5_OUT7_N)	
	IOM_MON0_10			IOM monitor input	
	QSPI1_SLSO6			O2	QSPI1 output (aka: SLSO16)
	QSPI3_SLSO11			O3	QSPI3 output (aka: SLSO311)
	ASCLIN1_SLSO	O4		ASCLIN1 output (aka: ASLSO1)	
	GTM_CLK1	O5		GTM output	
	SCU_EXTCLK1	O6		SCU output	
	CCU61_COUT61	O7		CCU61 output	
	IOM_MON1_12			IOM monitor input	
	IOM_REF1_9			IOM reference input	

Table 2-51 Port 40 Functions

Pin	Symbol	Ctrl.	Buffer Type	Function
40	P40.0	I	S / VDDM	General-purpose input
	VADCG0_0	AI		VADC input channel 0 of group 0
39	P40.1	I	S / VDDM	General-purpose input
	VADCG0_1	AI		VADC input channel 1 of group 0 (with multiplexer diagnostics)
38	P40.2	I	S / VDDM	General-purpose input
	VADCG0_2	AI		VADC input channel 2 of group 0 (with multiplexer diagnostics)
37	P40.3	I	S / VDDM	General-purpose input
	VADCG0_3	AI		VADC input channel 3 of group 0
36	P40.4	I	S / VDDM	General-purpose input
	VADCG0_4	AI		VADC input channel 4 of group 0
35	P40.5	I	S / VDDM	General-purpose input
	VADCG0_5	AI		VADC input channel 5 of group 0
34	P40.6	I	S / VDDM	General-purpose input
	VADCG0_6	AI		VADC input channel 6 of group 0
29	P40.7	I	S / VDDM	General-purpose input
	VADCG0_7	AI		VADC input channel 7 of group 0 (with pull down diagnostics)
28	P40.8	I	S / VDDM	General-purpose input
	VADCG0_8	AI		VADC input channel 8 of group 0
27	P40.9	I	S / VDDM	General-purpose input
	VADCG0_9	AI		VADC input channel 9 of group 0 (with multiplexer diagnostics)
26	P40.10	I	S / VDDM	General-purpose input
	VADCG0_10	AI		VADC input channel 10 of group 0 (with multiplexer diagnostics)
25	P40.11	I	S / VDDM	General-purpose input
	SENT_SENT0A			SENT input
	CCU60_CCPOS0D			CCU60 input
	VADCG0_11	AI		VADC input channel 11 of group 0

Table 2-52 Port 41 Functions

Pin	Symbol	Ctrl.	Buffer Type	Function
24	P41.0	I	S / VDDM	General-purpose input
	SENT_SENT1A			SENT input
	CCU60_CCPOS1B			CCU60 input
	VADCG1_0	AI	VADC input channel 0 of group 1	
23	P41.1	I	S / VDDM	General-purpose input
	VADCG1_1	AI		VADC input channel 1 of group 1 (with multiplexer diagnostics)
22	P41.2	I	S / VDDM	General-purpose input
	SENT_SENT2A			SENT input
	CCU61_CCPOS1B			CCU61 input
	VADCG1_2	AI	VADC input channel 2 of group 1 (with multiplexer diagnostics)	
21	P41.3	I	S / VDDM	General-purpose input
	SENT_SENT3A			SENT input
	CCU61_CCPOS1D			CCU61 input
	VADCG1_3	AI	VADC input channel 3 of group 1 (with pull down diagnostics)	
20	P41.4	I	S / VDDM	General-purpose input
	VADCG1_4	AI		VADC input channel 4 of group 1
19	P41.5	I	S / VDDM	General-purpose input
	VADCG1_5	AI		VADC input channel 5 of group 1
18	P41.6	I	S / VDDM	General-purpose input
	VADCG1_6	AI		VADC input channel 6 of group 1
17	P41.7	I	S / VDDM	General-purpose input
	VADCG1_7	AI		VADC input channel 7 of group 1
16	P41.8	I	S / VDDM	General-purpose input
	VADCG1_8	AI		VADC input channel 8 of group 1
15	P41.9	I	S / VDDM	General-purpose input
	VADCG1_9	AI		VADC input channel 9 of group 1 (with multiplexer diagnostics)
14	P41.10	I	S / VDDM	General-purpose input
	VADCG1_10	AI		VADC input channel 10 of group 1 (with multiplexer diagnostics)
13	P41.11	I	S / VDDM	General-purpose input
	VADCG1_11	AI		VADC input channel 11 of group 1

Package and Pinning Definitions PG-TQFP-100-23 Package Variant Pin

Table 2-53 System I/O

Pin	Symbol	Ctrl.	Buffer Type	Function
53	XTAL1	I	VDDP3	Main Oscillator/PLL/Clock Generator Input
54	XTAL2	O	VDDP3	Main Oscillator/PLL/Clock Generator Output
60	TMS/DAP1	I	A1+ / PD /	Debug Interface
	DAP1	I/O	VDDP3	Device Access Port Line 1
62	$\overline{\text{TRST}}$	I	Input Only / PD / VDDP3	JTAG Module Reset/Enable Input
63	TCK/DAP0	I	Input Only	OCDS input
	DAP0	I	/ PD / VDDP3	Device Access Port Line 0
65	$\overline{\text{ESR1}}$	I/O	A1+ / PU /	SCU input
	EVRWUP	I	VDDP3	EVR Wakeup Pin
66	$\overline{\text{PORST}}$	I	Input Only / PD / VDDP3	Power On Reset Additional strong PD in case of power fail.
67	$\overline{\text{ESR0}}$	I/O	A1+ / OD /	SCU input/output
	EVRWUP	I	VDDP3	EVR Wakeup Pin

Table 2-54 Supply

Pin	Symbol	Ctrl.	Buffer Type	Function
30	V_{AGND}	I	—	Negative Analog Reference Voltage 0
31	V_{AREF}	I	—	Positive Analog Reference Voltage 0
86	V_{DDP3}	I	—	Digital I/O Power Supply (3.3V) This pin supplies also the Flash 3.3V.
47	V_{DDP3}	I	—	Digital I/O Power Supply (3.3V)
48	V_{DD}	I	—	Digital Core Power Supply (1.3V) Output of EVR13.
52	V_{DD}	I	—	Digital Core Power Supply (1.3V) This pin supplies also the main XTAL Oscillator/PLL (1.3V). A higher decoupling capacitor is therefore recommended to the VSS pin for better noise immunity.
55	V_{DDP3}	I	—	Digital I/O Power Supply (3.3V) This pin supplies also the main XTAL Oscillator/PLL (3.3V). A higher decoupling capacitor is therefore recommended to the VSS pin for better noise immunity.
33	V_{DDM}	I	—	ADC Power Supply (5.0V)
12	V_{DDP3}	I	—	Digital I/O Power Supply (3.3V)
11	V_{DD}	I	—	Digital Core Power Supply (1.3V)

Table 2-54 Supply (cont'd)

Pin	Symbol	Ctrl.	Buffer Type	Function
68	V _{DD}	I	—	Digital Core Power Supply (1.3V)
32	V _{SSM}	I	—	Analog Ground for VDDM

2.3.2 Pull-Up/Pull-Down Reset Behavior of the Pins

Table 2-55 List of Pull-Up/Pull-Down Reset Behavior of the Pins

Pins	$\overline{\text{PORST}} = 0$	$\overline{\text{PORST}} = 1$
all GPIOs	High-Z	
TDI, $\overline{\text{TESTMODE}}$	Pull-up	
$\overline{\text{PORST}}^{1)}$	Pull-down with I_{PORST} relevant	Pull-down with I_{PDLI} relevant
$\overline{\text{TRST}}$, TCK, TMS	Pull-down	
ESR0	The open-drain driver is used to drive low. ²⁾	Pull-up ³⁾
ESR1	Pull-up ³⁾	
P14.2, P14.3, P14.6	Pull-up	
P21.7 / TDO	Pull-up	High-Z/Pull-up ⁴⁾

- 1) Pull-down with I_{PORST} relevant is always activated when a primary supply monitor detects a violation.
- 2) Valid additionally after deactivation of $\overline{\text{PORST}}$ until the internal reset phase has finished. See the SCU chapter for details.
- 3) See the SCU_IOCRR register description.
- 4) Depends on JTAG/DAP selection with $\overline{\text{TRST}}$.

3 Electrical Specification

3.1 Parameter Interpretation

The parameters listed in this section partly represent the characteristics of the TC233 / TC234 / TC237 and partly its requirements on the system. To aid interpreting the parameters easily when evaluating them for a design, they are marked with an two-letter abbreviation in column "Symbol":

- **CC**
Such parameters indicate **C**ontroller **C**haracteristics which are a distinctive feature of the TC233 / TC234 / TC237 and must be regarded for a system design.
- **SR**
Such parameters indicate **S**ystem **R**quirements which must provided by the microcontroller system in which the TC233 / TC234 / TC237 designed in.

3.2 Absolute Maximum Ratings

Stresses above the values listed under “Absolute Maximum Ratings” may cause permanent damage to the device. This is a stress rating only and functional operation of the device at these or any other conditions above those indicated in the Operational Conditions of this specification is not implied. Exposure to absolute maximum rating conditions may affect device reliability.

Table 3-1 Absolute Maximum Ratings

Parameter	Symbol	Values			Unit	Note / Test Condition
		Min.	Typ.	Max.		
Storage Temperature	T_{ST} SR	-65	-	170	°C	upto 65h @ $T_J = 150^\circ\text{C}$; upto 15h @ $T_J = 170^\circ\text{C}$
Voltage at V_{DD} power supply pins with respect to V_{SS} ¹⁾	V_{DD} SR	-	-	1.9	V	
Voltage at V_{DDP3} power supply pins with respect to V_{SS}	V_{DDP3} SR	-	-	4.43	V	
Voltage at V_{DDM} power supply pin with respect to V_{SS}	V_{DDM} SR	-	-	7.0	V	
Voltage on all analog and class S input pins with respect to V_{SS} ²⁾	V_{IN} SR	-0.5	-	7.0	V	
Voltage on all other input pins with respect to V_{SS} ¹⁾²⁾	V_{IN} SR	-0.5	-	min($V_{DDP3} + 0.6$, 4.23)	V	Whatever is lower
Input current on any pin during overload condition ³⁾	I_{IN} SR	-10	-	10	mA	
Absolute maximum sum of all input circuit currents during overload condition ³⁾	ΣI_{IN} SR	-100	-	100	mA	

- 1) Valid for cumulated for up to 2.8h and pulse forms following a power supply switch on phase, where the rise and fall times are related to the system capacities and coils.
- 2) Voltages below V_{INmin} have no impact to the device reliability as long as the times and currents defined in section Pin Reliability in Overload for the affected pad(s) are not violated.
- 3) This parameter is an Absolute Maximum Rating. Exposure to Absolute Maximum Ratings for extended periods of time may damage the device.

3.3 Pin Reliability in Overload

When receiving signals from higher voltage devices, low-voltage devices experience overload currents and voltages that go beyond their own IO power supplies specification.

The following table defines overload conditions that will not cause any negative reliability impact if all the following conditions are met:

- full operation life-time is not exceeded
- **Operating Conditions** are met for
 - pad supply levels
 - temperature
- Parameters defined in **Absolute Maximum Ratings** are not violated

If a pin current is out of the **Operating Conditions** but within the overload parameters, then the parameters functionality of this pin as stated in the Operating Conditions can no longer be guaranteed. Operation is still possible in most cases but with relaxed parameters.

Note: An overload condition on one or more pins does not require a reset.

Table 3-2 Overload Parameters

Parameter	Symbol	Values			Unit	Note / Test Condition
		Min.	Typ.	Max.		
Input current on any digital pin during overload condition	I_{IN}	-5	-	5	mA	
Input current on analog input pin during overload condition	I_{INANA}	-1	-	3	mA	limited to 60h over lifetime
		-5	-	5	mA	
Absolute sum of all ADC inputs during overload condition	I_{INSCA}	-20	-	20	mA	
Absolute maximum sum of all input circuit currents during overload condition	ΣI_{INS}	-100	-	100	mA	
Inactive device pin current during overload condition ¹⁾	I_{ID}	-1	-	1	mA	All power supply voltages $V_{DDx} = 0$
Sum of all inactive device pin currents ¹⁾	I_{IDS}	-100	-	100	mA	
Overload coupling factor for digital inputs, negative ²⁾	K_{OVDN} CC	-	-	$1.5 \cdot 10^{-3}$		Overload injected on GPIO pad and affecting neighbor GPIO pad
Overload coupling factor for digital inputs, positive ²⁾	K_{OVDP} CC	-	-	$1 \cdot 10^{-5}$		Overload injected on GPIO pad and affecting neighbor GPIO pad
Overload coupling factor for analog inputs, negative	K_{OVAN} CC	-	-	$1 \cdot 10^{-3}$		Analog Inputs overlaid with pull down diagnostics
		-	-	$1 \cdot 10^{-4}$		else

Electrical Specification Pin Reliability in Overload

Table 3-2 Overload Parameters (cont'd)

Parameter	Symbol	Values			Unit	Note / Test Condition
		Min.	Typ.	Max.		
Overload coupling factor for analog inputs, positive	$K_{OVAP\ CC}$	-	-	$1 \cdot 10^{-4}$		Analog Inputs overlaid with pull down diagnostics
		-	-	$1 \cdot 10^{-5}$		else

- 1) Limitations for time and supply levels specified in this section are not valid for this parameter.
- 2) Overload is measured as increase of pad leakage caused by injection on neighbor pad.

Table 3-3 PN-Junction Characteristics for positive Overload

Pad Type	$I_{IN} = 3\text{ mA}$	$I_{IN} = 5\text{ mA}$
A1 / A1+	$U_{IN} = V_{DDP3} + 0.5\text{ V}$	$U_{IN} = V_{DDP3} + 0.6\text{ V}$
D	$U_{IN} = V_{DDM} + 0.75\text{ V}$	-

Table 3-4 PN-Junction Characteristics for negative Overload

Pad Type	$I_{IN} = -3\text{ mA}$	$I_{IN} = -5\text{ mA}$
A1 / A1+	$U_{IN} = V_{SS} - 0.5\text{ V}$	$U_{IN} = V_{SS} - 0.6\text{ V}$
D	$U_{IN} = V_{SS} - 0.75\text{ V}$	-

3.4 Operating Conditions

The following operating conditions must not be exceeded in order to ensure correct operation and reliability of the TC233 / TC234 / TC237. All parameters specified in the following tables refer to these operating conditions, unless otherwise noticed.

Digital supply voltages applied to the TC233 / TC234 / TC237 must be static regulated voltages.

All parameters specified in the following tables refer to these operating conditions (see table below), unless otherwise noticed in the Note / Test Condition column.

Table 3-5 Operating Conditions

Parameter	Symbol	Values			Unit	Note / Test Condition
		Min.	Typ.	Max.		
SRI frequency	f_{SRI} SR	-	-	200	MHz	
		-	-	133	MHz	vaild only for SAK-TC233LC-24F133F
Max System Frequency	f_{MAX} SR	-	-	200	MHz	
		-	-	133	MHz	vaild only for SAK-TC233LC-24F133F
CPU0 Frequency	f_{CPU0} SR	-	-	200	MHz	
		-	-	133	MHz	vaild only for SAK-TC233LC-24F133F
PLL output frequency	f_{PLL} SR	20	-	200	MHz	
		-	-	133	MHz	vaild only for SAK-TC233LC-24F133F
PLL_ERAY output frequency	f_{PLLERAY} SR	20	-	160	MHz	
		-	-	80	MHz	vaild only for SAK-TC233LC-24F133F
SPB frequency	f_{SPB} SR	-	-	100	MHz	
ASCLIN fast frequency	f_{ASCLINF} SR	-	-	200	MHz	
		-	-	133	MHz	vaild only for SAK-TC233LC-24F133F
ASCLIN slow frequency	f_{ASCLINS} SR	-	-	100	MHz	
Baud2 frequency	f_{BAUD2} SR	-	-	200	MHz	
		-	-	133	MHz	vaild only for SAK-TC233LC-24F133F
FSI2 frequency	f_{FSI2} SR	-	-	200	MHz	
		-	-	133	MHz	vaild only for SAK-TC233LC-24F133F
FSI frequency	f_{FSI} SR	-	-	100	MHz	
GTM frequency	f_{GTM} SR	-	-	100	MHz	
STM frequency	f_{STM} SR	-	-	100	MHz	
ERAY frequency	f_{ERAY} SR	-	-	80	MHz	
BBB frequency	f_{BBB} SR	-	-	100	MHz	
MultiCAN frequency	f_{CAN} SR	-	-	100	MHz	

Table 3-5 Operating Conditions (cont'd)

Parameter	Symbol	Values			Unit	Note / Test Condition
		Min.	Typ.	Max.		
Absolute sum of short circuit currents of the device	ΣI_{SC_D} SR	-	-	100	mA	
Ambient Temperature	T_A SR	-40	-	125	°C	valid for all SAK products
		-40	-	150	°C	valid for all SAL products
Junction Temperature	T_J SR	-40	-	150	°C	valid for all SAK products
		-40	-	165	°C	valid for all SAL products
Core Supply Voltage ¹⁾	V_{DD} SR	1.17	1.3	1.43 ²⁾	V	Only required if externally supplied
ADC analog supply voltage	V_{DDM} SR	2.97	5.0	5.5 ³⁾	V	
Digital ground voltage	V_{SS} SR	0	-	-	V	
Analog ground voltage for V_{DDM}	V_{SSM} CC	-0.1	0	0.1	V	
Voltage to ensure defined pad states ⁴⁾	V_{DDPPA} CC	0.72	-	-	V	
Digital supply voltage for GPIO pads and EVR ⁵⁾	V_{DDP3} SR	2.97	3.3	3.63	V	

- 1) No external inductive load permissible if EVR is used. All V_{DD} pins shall be connected together externally on the PCB.
- 2) Voltage overshoot to 1.69V is permissible, provided the duration is less than 2h cumulated. Reduced ADC accuracy and leakage is increased.
- 3) Voltage overshoot to 6.5V is permissible, provided the duration is less than 2h cumulated. Reduced ADC accuracy and leakage is increased.
- 4) This parameter is valid under the assumption the PORST signal is constantly at low level during the power-up/power-down of V_{DDP3} .
- 5) All V_{DDP3} pins shall be connected together externally on the PCB.

3.5 3.3 V Pads
Table 3-6 Standard Pads

Parameter	Symbol	Values			Unit	Note / Test Condition
		Min.	Typ.	Max.		
Pin capacitance (digital inputs/outputs)	C_{IO} CC	-	6	10	pF	
Spike filter always blocked pulse duration	t_{SF1} CC	-	-	80	ns	PORST only
Spike filter pass-through pulse duration	t_{SF2} CC	220	-	-	ns	PORST only
PORST pad output current ¹⁾	I_{PORST} CC	10.1	-	-	mA	$V_{DDP3} = 3.0V$; $V_{PORST} = 0.9V$; $T_J = 150^{\circ}C$;

1) Pull-down with I_{PORST} relevant is always activated when a primary supply monitor detects a violation.

Table 3-7 Class_A1

Parameter	Symbol	Values			Unit	Note / Test Condition
		Min.	Typ.	Max.		
Input frequency	f_{IN} SR	-	-	100	MHz	
Input Hysteresis A1	HYS_{A1} CC	0.1 * V_{DDP3}	-	-	V	else
Input Leakage Current Class A1	I_{OZA1} CC	-400	-	400	nA	$(0.1 * V_{DDP3}) < V_{IN} < (0.9 * V_{DDP3})$
		-475	-	475	nA	$(0.1 * V_{DDP3}) < V_{IN} < (0.9 * V_{DDP3})$; only valid for P0.0
		-800	-	800	nA	else
Pull-down current class A1 pads	I_{PDLA1} CC	-	-	120	μA	V_{IHmin}
		15	-	-	μA	V_{ILmax}
Pull-up current class A1 pads	I_{PUHA1} CC	15	-	-	μA	V_{IHmin}
		-	-	120	μA	V_{ILmax}
On-Resistance of the A1 pad, medium driver	$R_{DSONA1M}$ CC	50	125	200	Ohm	$I_{OH}=2mA$; $I_{OL}=2mA$
On-Resistance of the class A1 pad, weak driver	$R_{DSONA1W}$ CC	250	500	800	Ohm	$I_{OH}=0.5mA$; $I_{OL}=0.5mA$
Input high voltage class A1 pads	V_{IHA1} CC	0.7 * V_{DDP3}	-	-	V	CMOS
Input low voltage, class A1 pads	V_{ILA1} CC	-	-	0.3 * V_{DDP3}	V	CMOS

Electrical Specification 3.3 V Pads

Table 3-7 Class_A1 (cont'd)

Parameter	Symbol	Values			Unit	Note / Test Condition
		Min.	Typ.	Max.		
Rise/fall time ¹⁾	t_{A1} CC	-	-	10+0.4 * C_L	ns	$C_L \leq 100\text{pF}$; pin out driver=medium
		-	-	30+2.0 * C_L	ns	$C_L \leq 100\text{pF}$; pin out driver=weak

 1) Rise / fall times are defined 10% - 90% of V_{DDP3} .

Table 3-8 Class_A1+

Parameter	Symbol	Values			Unit	Note / Test Condition
		Min.	Typ.	Max.		
Input frequency	f_{IN} SR	-	-	75	MHz	
Input Leakage Current Class A1+	I_{OZA1+} CC	-1	-	1	μA	$(0.1 \cdot V_{DDP3}) < V_{IN} < (0.9 \cdot V_{DDP3})$
		-2	-	2	μA	else
Pull-down current class A1+ pads	I_{PDLA1+} CC	-	-	120	μA	V_{IHmin}
		15	-	-	μA	V_{ILmax}
Pull-up current class A1+ pads	I_{PUHA1+} CC	15	-	-	μA	V_{IHmin}
		-	-	120	μA	V_{ILmax}
On-Resistance of the A1+ pad, medium driver	$R_{DSONA1+M}$ CC	50	125	200	Ohm	$I_{OH}=2\text{mA}$; $I_{OL}=2\text{mA}$
On-Resistance of the A1+ pad, strong driver	$R_{DSONA1+S}$ CC	10	40	65	Ohm	$I_{OH}=6\text{mA}$; $I_{OL}=6\text{mA}$
On-Resistance of the A1+ pad, weak driver	$R_{DSONA1+W}$ CC	250	500	800	Ohm	$I_{OH}=0.5\text{mA}$; $I_{OL}=0.5\text{mA}$
Input high voltage, Class A1+ pads	V_{IHA1+} CC	0.7 * V_{DDP3}	-	-	V	CMOS
Input low voltage Class A1+ pads	V_{ILA1+} CC	-	-	0.3 * V_{DDP3}	V	CMOS
Rise/fall time ¹⁾	t_{A1+} CC	-	-	8+0.14 * C_L	ns	$C_L \leq 100\text{pF}$; edge=slow ; pin out driver=strong (sw)
		-	-	1+0.14 * C_L	ns	$C_L \leq 100\text{pF}$; edge=soft ; pin out driver=strong (sf)
		-	-	10+0.4 * C_L	ns	$C_L \leq 100\text{pF}$; pin out driver=medium
		-	-	30+2.0 * C_L	ns	$C_L \leq 100\text{pF}$; pin out driver=weak
Input Hysteresis A1+	HYS_{A1+} CC	0.1 * V_{DDP3}	-	-	V	else

 1) Rise / fall times are defined 10% - 90% of V_{DDP3} .

Electrical Specification 3.3 V Pads

Table 3-9 Class_S

Parameter	Symbol	Values			Unit	Note / Test Condition
		Min.	Typ.	Max.		
Input frequency	f_{IN} SR	-	-	75	MHz	
Input Hysteresis for S pad ¹⁾	H_{YSS} CC	0.3	-	-	V	
Pull-up current for S pad	I_{PUHS} CC	11	-	-	μ A	V_{IHmin}
		-	-	120	μ A	V_{ILmax}
Pull-down current for S pad	I_{PDLS} CC	-	-	120	μ A	V_{IHmin}
		30	-	-	μ A	V_{ILmax}
Input Leakage current Class S	I_{OZS} CC	-350	-	350	nA	Analog Inputs overlaid with pull down diagnosis
		-150	-	150	nA	else
Input voltage high for S pad	V_{IHS} SR	-	-	3.8 ²⁾	V	
Input voltage low for S pad	V_{ILS} SR	1.39 ³⁾	-	-	V	
Input low threshold variation for S pad ⁴⁾	V_{ILSD} SR	-50	-	50	mV	max. variation of 1ms; V_{DDM} =constant
Input capacitance for S pad	C_{INS} CC	-	-	10	pF	
Pad set-up time for S pad	t_{SETS} CC	-	-	100	ns	

- 1) Hysteresis is implemented to avoid metastable states and switching due to internal ground bounce. It can't be guaranteed that it suppresses switching due to external system noise.
- 2) $V_{ILx} = 0.65 * V_{DDM}$
- 3) $V_{ILx} = 0.41 * V_{DDM}$
- 4) VILSD is implemented to ensure J2716 specification. For details of dedicated pins please see AP32286 for details.

Table 3-10 Class I

Parameter	Symbol	Values			Unit	Note / Test Condition
		Min.	Typ.	Max.		
Input frequency	f_{IN} SR	-	-	100	MHz	
Input Hysteresis for I pad ¹⁾	H_{YSI} CC	0.1 * V_{DDP3}	-	-	V	
Pull-up current for I pad	I_{PUHI} CC	15	-	-	μ A	V_{IHmin}
		-	-	120	μ A	V_{ILmax}
Pull-down current for I pad	I_{PDLI} CC	-	-	120	μ A	V_{IHmin}
		15	-	-	μ A	V_{ILmax}
Input Leakage Current for I pad	I_{OZI} CC	-150	-	150	nA	$(0.1 * V_{DDP3}) < V_{IN} < (0.9 * V_{DDP3})$
		-500	-	350	nA	else
Input high voltage for I pad	V_{IHI} SR	0.7 * V_{DDP3}	-	-	V	CMOS

Table 3-10 Class I (cont'd)

Parameter	Symbol	Values			Unit	Note / Test Condition
		Min.	Typ.	Max.		
Input low voltage for I pad	V_{IL1} SR	-	-	0.3 * V_{DDP3}	V	CMOS
Pad set-up time for I pad	t_{SETI} CC	-	-	100	ns	

1) Hysteresis is implemented to avoid metastable states and switching due to internal ground bounce. It can't be guaranteed that it suppresses switching due to external system noise.

Table 3-11 Driver Mode Selection for A1 Pads

PDx.2	PDx.1	PDx.0	Port Functionality	Driver Setting
X	X	0	Speed grade 1	medium (A1m)
X	X	1	Speed grade 2	weak (A1w)

Table 3-12 Driver Mode Selection for A1+ Pads

PDx.2	PDx.1	PDx.0	Port Functionality	Driver Setting
X	0	0	Speed grade 1	Strong soft edge (A1+sf)
X	0	1	Speed grade 2	Strong slow edge (A1+sw)
X	1	0	Speed grade 3	medium (A1+m)
X	1	1	Speed grade 4	weak (A1+w)

3.6 VADC Parameters

VADC parameter are valid for $V_{DDM} = 4.5 \text{ V}$ to 5.5 V .

This table also covers the parameters for Class D pads.

Table 3-13 VADC

Parameter	Symbol	Values			Unit	Note / Test Condition
		Min.	Typ.	Max.		
Analog reference voltage ¹⁾	V_{AREF} SR	$V_{AGND} + 1.0$	-	$V_{DDM} + 0.05$	V	
Analog reference ground	V_{AGND} SR	$V_{SSM} - 0.05$	-	$V_{SSM} + 0.05$	V	
Analog input voltage range	V_{AIN} SR	V_{AGND}	-	V_{AREF}	V	
Converter reference clock	f_{ADCI} SR	2	-	20	MHz	
Charge consumption per conversion ^{2) 3)}	Q_{CONV} CC	-	50	75	pC	$V_{AIN} = 5 \text{ V}$, charge consumed from reference pin, precharging disabled
		-	10	22	pC	$V_{AIN} = 5 \text{ V}$, charge consumed from reference pin, precharging enabled
Conversion time for 12-bit result	t_{C12} CC	-	$(16 + \text{STC}) \times t_{ADCI} + 2 \times t_{VADC}$	-		Includes sample time and post calibration
Conversion time for 10-bit result	t_{C10} CC	-	$(14 + \text{STC}) \times t_{ADCI} + 2 \times t_{VADC}$	-		Includes sample time
Conversion time for 8-bit result	t_{C8} CC	-	$(12 + \text{STC}) \times t_{ADCI} + 2 \times t_{VADC}$	-		Includes sample time
Conversion time for fast compare mode	t_{CF} CC	-	$(4 + \text{STC}) \times t_{ADCI} + 2 \times t_{VADC}$	-		Includes sample time
Broken wire detection delay against V_{AGND} ⁴⁾	t_{BWG} CC	-	-	120	cycles	Result below 10%
Broken wire detection delay against V_{AREF} ⁵⁾	t_{BWR} CC	-	-	60	cycles	Result above 80%
Input leakage at analog inputs	I_{OZ1} CC	-350	-	350	nA	Analog Inputs overlaid with pull down diagnosis
		-150	-	150	nA	else
Total Unadjusted Error ¹⁾	TUE CC	-4 ⁶⁾	-	4 ⁶⁾	LSB	12-bit resolution

Electrical Specification VADC Parameters

Table 3-13 VADC (cont'd)

Parameter	Symbol	Values			Unit	Note / Test Condition
		Min.	Typ.	Max.		
INL Error	EA_{INL} CC	-3	-	3	LSB	12-bit resolution
Gain Error ¹⁾	EA_{GAIN} CC	-3.5	-	3.5	LSB	12-bit resolution
DNL error ¹⁾	EA_{DNL} CC	-3	-	3	LSB	12-bit resolution
Offset Error ¹⁾	EA_{OFF} CC	-4	-	4	LSB	12-bit resolution
Total capacitance of an analog input	C_{AINT} CC	-	-	30	pF	
Switched capacitance of an analog input	C_{AINS} CC	2	-	7	pF	
Resistance of the analog input path	R_{AIN} CC	-	-	1.5	kOhm	
Switched capacitance of a reference input	C_{AREFS} CC	-	-	30	pF	
RMS Noise ⁷⁾	EN_{RMS} CC	-	0.5	0.8 ⁶⁾⁸⁾	LSB	
Positive reference V_{AREFX} pin leakage	I_{OZ2} CC	-2	-	2	μ A	$V_{AREFX} = V_{AREF}$; $T_J > 150^\circ\text{C}$
		-1	-	1	μ A	$V_{AREFX} = V_{AREF}$; $T_J \leq 150^\circ\text{C}$
Negative reference V_{AGNDx} pin leakage	I_{OZ3} CC	-2.5	-	2.5	μ A	$V_{AGNDx} = V_{AGND}$; $T_J > 150^\circ\text{C}$
		-1.5	-	1.5	μ A	$V_{AGNDx} = V_{AGND}$; $T_J \leq 150^\circ\text{C}$
Resistance of the reference input path	R_{AREF} CC	-	-	1	kOhm	
CSD resistance ⁹⁾	R_{CSD} CC	-	-	28	kOhm	
Resistance of the multiplexer diagnostics pull-down device	R_{MDD} CC	$25 + 1 \cdot V_{IN}$	-	$35 - 8 \cdot V_{IN}$	kOhm	$0 \text{ V} \leq V_{IN} \leq 2.5 \text{ V}$
		$-5 + 13 \cdot V_{IN}$	-	$15 + 16 \cdot V_{IN}$	kOhm	$2.5 \text{ V} \leq V_{IN} \leq V_{DDM}$
Resistance of the multiplexer diagnostics pull-up device	R_{MDU} CC	$45 - 6 \cdot V_{IN}$	-	$90 - 16 \cdot V_{IN}$	kOhm	$0 \text{ V} \geq V_{IN} \leq 2.5 \text{ V}$
		$40 - 4 \cdot V_{IN}$	-	$65 - 6 \cdot V_{IN}$	kOhm	$2.5 \text{ V} \leq V_{IN} \leq V_{DDM}$
Resistance of the pull-down test device ¹⁰⁾	R_{PDD} CC	-	-	0.3	kOhm	
CSD voltage accuracy ^{11) 12)}	$dVCSD$ CC	-	-	10	%	
Wakeup time	t_{WU} CC	-	-	12	μ s	

- 1) If the reference voltage is reduced by the factor k ($k < 1$), TUE, DNL, INL, Gain, and Offset errors increase also by the factor $1/k$. V_{AREF} must be decoupled with an external capacitor.
- 2) For $QCONV = X$ pC and a conversion time of 1μ s a rms value of $X \mu$ A results for I_{AREFX} .
- 3) For the details of the mapping for a VADC group to pin V_{AREFX} please see the User's Manual.
- 4) The broken wire detection delay against V_{AGND} is measured in numbers of consecutive precharge cycles at a conversion rate higher than 1 conversion per 500 ms.
- 5) The broken wire detection delay against V_{AREF} is measured in numbers of consecutive precharge cycles at a conversion rate higher than 1 conversion per 10 ms. This function is influenced by leakage current, in particular at high temperature.

Electrical Specification VADC Parameters

- 6) Resulting worst case combined error is arithmetic combination of TUE and EN_{RMS} .
- 7) This parameter is valid for soldered devices and requires careful analog board design.
- 8) Value is defined for one sigma Gauss distribution.
- 9) In order to avoid an additional error due to incomplete sampling, the sampling time shall be set greater than $5 * R_{CSD} * C_{AINS}$.
- 10) The pull-down resistor R_{PDD} is connected between the input pad and the analog multiplexer. The input pad itself adds another 200-Ohm series resistance, when measuring through the pin.
- 11) CSD: Converter Self Diagnostics, for details please consult the User's Manual.
- 12) Note, that in case CSD voltage is chosen to nom. 1/3 or 2/3 of V_{AREF} voltage, the reference voltage is loaded with a current of max. $V_{AREF} / 45$ kOhm.

VADC parameter are valid for $V_{DDM} = 2.97$ V to 4.5 V.

Table 3-14 VADC_33

Parameter	Symbol	Values			Unit	Note / Test Condition
		Min.	Typ.	Max.		
Analog reference voltage ¹⁾	V_{AREF} SR	$V_{AGND} + 1.0$	-	$V_{DDM} + 0.05$	V	
Analog reference ground	V_{AGND} SR	$V_{SSM} - 0.05$	-	$V_{SSM} + 0.05$	V	
Analog input voltage range	V_{AIN} SR	V_{AGND}	-	V_{AREF}	V	
Converter reference clock	f_{ADCI} SR	2	-	20	MHz	
Charge consumption per conversion ^{2) 3)}	Q_{CONV} CC	-	35	50	pC	$V_{AIN} = 3.3$ V, charge consumed from reference pin, precharging disabled
		-	8	17	pC	$V_{AIN} = 3.3$ V, charge consumed from reference pin, precharging enabled
Conversion time for 12-bit result	t_{C12} CC	-	$(16 + STC) \times t_{ADCI} + 2 \times t_{VADC}$	-		Includes sample time and post calibration
Conversion time for 10-bit result	t_{C10} CC	-	$(14 + STC) \times t_{ADCI} + 2 \times t_{VADC}$	-		Includes sample time
Conversion time for 8-bit result	t_{C8} CC	-	$(12 + STC) \times t_{ADCI} + 2 \times t_{VADC}$	-		Includes sample time
Conversion time for fast compare mode	t_{CF} CC	-	$(4 + STC) \times t_{ADCI} + 2 \times t_{VADC}$	-		Includes sample time
Broken wire detection delay against V_{AGND} ⁴⁾	t_{BWG} CC	-	-	120	cycles	Result below 10%

Electrical Specification VADC Parameters

Table 3-14 VADC_33 (cont'd)

Parameter	Symbol	Values			Unit	Note / Test Condition
		Min.	Typ.	Max.		
Broken wire detection delay against V_{AREF} ⁵⁾	t_{BWR} CC	-	-	60	cycles	Result above 80%
Input leakage at analog inputs	I_{OZ1} CC	-350	-	350	nA	Analog Inputs overlaid with pull down diagnostics
		-150	-	150	nA	else
Total Unadjusted Error ¹⁾	TUE CC	-12	-	12	LSB	12-bit Resolution; $T_J > 150\text{ }^\circ\text{C}$
		-6	-	6	LSB	12-bit Resolution; $T_J \leq 150\text{ }^\circ\text{C}$
INL Error	EA_{INL} CC	-12	-	12	LSB	12-bit Resolution; $T_J > 150\text{ }^\circ\text{C}$
		-5	-	5	LSB	12-bit Resolution; $T_J \leq 150\text{ }^\circ\text{C}$
Gain Error ¹⁾	EA_{GAIN} CC	-6	-	6	LSB	12-bit Resolution; $T_J > 150\text{ }^\circ\text{C}$
		-5.5	-	5.5	LSB	12-bit Resolution; $T_J \leq 150\text{ }^\circ\text{C}$
DNL error ¹⁾	EA_{DNL} CC	-4	-	4	LSB	12-bit resolution
Offset Error ¹⁾	EA_{OFF} CC	-6	-	6	LSB	12-bit Resolution; $T_J > 150\text{ }^\circ\text{C}$
		-5	-	5	LSB	12-bit Resolution; $T_J \leq 150\text{ }^\circ\text{C}$
Total capacitance of an analog input	C_{AINT} CC	-	-	30	pF	
Switched capacitance of an analog input	C_{AINS} CC	2	4	7	pF	
Resistance of the analog input path	R_{AIN} CC	-	-	4.5	kOhm	
Switched capacitance of a reference input	C_{AREFS} CC	-	-	30	pF	
RMS Noise ⁶⁾	EN_{RMS} CC	-	-	1.7	LSB	
Positive reference V_{AREFX} pin leakage	I_{OZ2} CC	-2	-	2	μA	$V_{AREFX} = V_{AREF}$; $T_J > 150\text{ }^\circ\text{C}$
		-1	-	1	μA	$V_{AREFX} = V_{AREF}$; $T_J \leq 150\text{ }^\circ\text{C}$
Negative reference V_{AGNDx} pin leakage	I_{OZ3} CC	-2.5	-	2.5	μA	$V_{AGNDx} = V_{AGND}$; $T_J > 150\text{ }^\circ\text{C}$
		-1	-	1	μA	$V_{AGNDx} = V_{AGND}$; $T_J \leq 150\text{ }^\circ\text{C}$
Resistance of the reference input path	R_{AREF} CC	-	-	3	kOhm	

Table 3-14 VADC_33 (cont'd)

Parameter	Symbol	Values			Unit	Note / Test Condition
		Min.	Typ.	Max.		
CSD resistance ⁷⁾	R_{CSD} CC	-	-	28	kOhm	
Resistance of the multiplexer diagnostics pull-down device	R_{MDD} CC	$25 + 3 \cdot V_{IN}$	-	$40 + 12 \cdot V_{IN}$	kOhm	$0 \text{ V} \leq V_{IN} \leq 1.667 \text{ V}$
		$0 + 18 \cdot V_{IN}$	-	$0 + 18 \cdot V_{IN}$	kOhm	$1.667 \text{ V} \leq V_{IN} \leq V_{DDM}$
Resistance of the multiplexer diagnostics pull-up device	R_{MDU} CC	$60 - 12 \cdot V_{IN}$	-	$120 - 30 \cdot V_{IN}$	kOhm	$0 \text{ V} \leq V_{IN} \leq 1.667 \text{ V}$
		$55 - 9 \cdot V_{IN}$	-	$95 - 15 \cdot V_{IN}$	kOhm	$1.667 \text{ V} \leq V_{IN} \leq V_{DDM}$
Resistance of the pull-down test device ⁸⁾	R_{PDD} CC	-	-	0.9	kOhm	
CSD voltage accuracy ^{9) 10)}	$dVCSD$ CC	-	-	10	%	
Wakeup time	t_{WU} CC	-	-	12	μs	

- 1) If the reference voltage is reduced by the factor k ($k < 1$), TUE, DNL, INL, Gain, and Offset errors increase also by the factor $1/k$. V_{AREF} must be decoupled with an external capacitor.
- 2) For $QCONV = X \text{ pC}$ and a conversion time of $1 \text{ } \mu\text{s}$ a rms value of $X \text{ } \mu\text{A}$ results for I_{AREFX} .
- 3) For the details of the mapping for a VADC group to pin V_{AREFX} please see the User's Manual.
- 4) The broken wire detection delay against V_{AGND} is measured in numbers of consecutive precharge cycles at a conversion rate higher than 1 conversion per 500 ms.
- 5) The broken wire detection delay against V_{AREF} is measured in numbers of consecutive precharge cycles at a conversion rate higher than 1 conversion per 10 ms. This function is influenced by leakage current, in particular at high temperature.
- 6) This parameter is valid for soldered devices and requires careful analog board design.
- 7) In order to avoid an additional error due to incomplete sampling, the sampling time shall be set greater than $5 \cdot R_{CSD} \cdot C_{AINS}$.
- 8) The pull-down resistor R_{PDD} is connected between the input pad and the analog multiplexer. The input pad itself adds another 200-Ohm series resistance, when measuring through the pin.
- 9) CSD: Converter Self Diagnostics, for details please consult the User's Manual.
- 10) Note, that in case CSD voltage is chosen to nom. 1/3 or 2/3 of V_{AREF} voltage, the reference voltage is loaded with a current of max. $V_{AREF} / 45 \text{ kOhm}$.

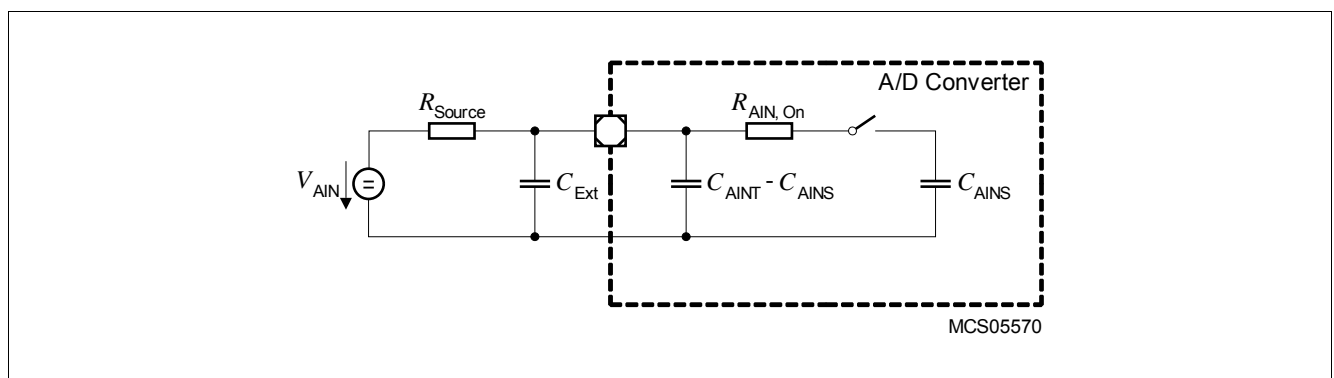

Figure 3-1 Equivalent Circuitry for Analog Inputs

3.7 MHz Oscillator

OSC_XTAL is used as accurate and exact clock source. OSC_XTAL supports 8 MHz to 40 MHz crystals external outside of the device. Support of ceramic resonators is also provided.

Table 3-15 OSC_XTAL

Parameter	Symbol	Values			Unit	Note / Test Condition
		Min.	Typ.	Max.		
Input current at XTAL1	I_{IX1} CC	-25	-	25	μA	$V_{IN} > 0\text{V}; V_{IN} < V_{DDP3}$ V
Oscillator frequency	f_{OSC} SR	4	-	40	MHz	Direct Input Mode selected
		8	-	40	MHz	External Crystal Mode selected
Oscillator start-up time ¹⁾	t_{OSCS} CC	-	-	5 ²⁾	ms	
Input high voltage at XTAL1	V_{IHBX} SR	0.8	-	$V_{DDP3} + 0.5$	V	If shaper is bypassed
Input low voltage at XTAL1	V_{ILBX} SR	-0.5	-	0.4	V	If shaper is bypassed
Input voltage at XTAL1	V_{IX} SR	-0.5	-	$V_{DDP3} + 0.5$	V	If shaper is not bypassed
Input amplitude (peak to peak) at XTAL1	V_{PPX} SR	0.3 * V_{DDP3}	-	$V_{DDP3} + 1.0$	V	If shaper is not bypassed; $f_{OSC} > 25\text{MHz}$
		0.4 * V_{DDP3}	-	$V_{DDP3} + 1.0$	V	If shaper is not bypassed; $f_{OSC} \leq 25\text{MHz}$

1) t_{OSCS} is defined from the moment when $V_{DDP3} = 3.13\text{V}$ until the oscillations reach an amplitude at XTAL1 of $0.3 * V_{DDP3}$. The external oscillator circuitry must be optimized by the customer and checked for negative resistance as recommended and specified by crystal suppliers.

2) This value depends on the frequency of the used external crystal. For faster crystal frequencies this value decrease.

Note: It is strongly recommended to measure the oscillation allowance (negative resistance) in the final target system (layout) to determine the optimal parameters for the oscillator operation. Please refer to the limits specified by the crystal or ceramic resonator supplier.

3.8 Back-up Clock

The back-up clock provides an alternative clock source.

Table 3-16 Back-up Clock

Parameter	Symbol	Values			Unit	Note / Test Condition
		Min.	Typ.	Max.		
Back-up clock before trimming	f_{BACKUT} CC	75	100	125	MHz	
Slow speed Back-up clock	f_{BACKSS} CC	75	100	125	kHz	
Back-up clock after trimming	f_{BACKT} CC	97.5	100	102.5	MHz	

3.9 Temperature Sensor

Table 3-17 DTS

Parameter	Symbol	Values			Unit	Note / Test Condition
		Min.	Typ.	Max.		
Measurement time	t_M CC	-	-	100	μs	
Calibration reference accuracy	T_{CALACC} CC	-1	-	1	°C	calibration points @ $T_J = -40^\circ\text{C}$ and $T_J = 127^\circ\text{C}$
Non-linearity accuracy over temperature range	T_{NL} CC	-2	-	2	°C	
Temperature sensor range	T_{SR} SR	-40	-	170	°C	
Start-up time after resets inactive	t_{TSST} SR	-	-	20	μs	

The following formula calculates the temperature measured by the DTS in [°C] from the RESULT bit field of the DTSSTAT register.

(3.1)

$$T_J = \frac{DTSSTATRESULT - (607)}{2, 13}$$

3.10 Power Supply Current

The total power supply current defined below consists of leakage and switching component.

Application relevant values are typically lower than those given in the following table and depend on the customer's system operating conditions (e.g. thermal connection or used application configurations).

The operating conditions for the parameters in the following table are:

The real (realistic) power pattern defines the following conditions:

- $T_J = 150\text{ °C}$
- $f_{SRI} = f_{MAX} = f_{CPU0} = 200\text{ MHz}$
- $f_{SPB} = f_{STM} = f_{GTM} = f_{BAUD1} = f_{BAUD2} = f_{ASCLIN} = 40\text{ MHz}$
- $V_{DD} = 1.326\text{ V}$
- $V_{DDP3} = 3.366\text{ V}$
- $V_{DDM} = 5.1\text{ V}$
- core is active
- the following peripherals are inactive: HSM, Ethernet, and MTU

The max power pattern defines the following conditions:

- $T_J = 150\text{ °C}$
- $f_{SRI} = f_{MAX} = f_{CPU0} = 200\text{ MHz}$
- $f_{SPB} = f_{STM} = f_{GTM} = f_{BAUD1} = f_{BAUD2} = f_{ASCLIN} = 100\text{ MHz}$
- $V_{DD} = 1.43\text{ V}$
- $V_{DDP3} = 3.63\text{ V}$
- $V_{DDM} = 5.5\text{ V}$
- core is active
- all peripherals are active

Table 3-18 Power Supply

Parameter	Symbol	Values			Unit	Note / Test Condition
		Min.	Typ.	Max.		
Σ Sum of I_{DD} 1.3 V core and peripheral supply currents	I_{DD} CC	-	-	215 ¹⁾	mA	valid for Feature Package L, LC, LP, S, and SP; max power pattern
		-	-	160	mA	valid for Feature Package L, LC, LP, S, and SP; real power pattern

Electrical Specification Power Supply Current

Table 3-18 Power Supply (cont'd)

Parameter	Symbol	Values			Unit	Note / Test Condition
		Min.	Typ.	Max.		
I_{DD} core current during active power-on reset (PORST held low)	$I_{DDPORST}$ CC	-	-	85	mA	valid for Feature Package L, LC, LP, S, and SP; $T_J=165^\circ\text{C}$
		-	-	60	mA	valid for Feature Package L, LC, LP, S, and SP; $T_J=150^\circ\text{C}$
		-	-	40	mA	valid for Feature Package L, LC, LP, S, and SP; $T_J=125^\circ\text{C}$
I_{DD} core current of CPU0 lockstep core active	I_{DDC01} CC	-	-	34	mA	real power pattern
I_{DD} core current added by HSM	I_{DDHSM} CC	-	-	20	mA	HSM running at 100MHz.
I_{DD} core current added by FFT	I_{DDFFT} CC	-	-	40	mA	FFT running at 200MHz
Σ Sum of 3.3 V supply currents without pad activity	$I_{DDx3RAIL}$ CC	-	-	34 ²⁾	mA	real power pattern; incl. OSC, EVR and Pflash read current
		-	-	44	mA	incl. OSC, EVR, Pflash read and Pflash programming current.
I_{DDM} supply current	I_{DDM} CC	-	-	6	mA	max pattern; current for 2x VADC modules.
Σ Sum of all currents with DC-DC EVR13 regulator active ³⁾	$I_{DDTOTDC3}$ CC	-	-	129	mA	real power pattern; $V_{DDP3} = 3.3V$
Σ Sum of all currents (incl. $I_{DDP3RAIL}+I_{DD}+I_{DDM}$)	I_{DDTOTL} CC	-	-	200	mA	valid for Feature Package L, LC, LP, S, and SP; real power pattern
Σ Sum of all currents (STANDBY mode)	I_{EVRSB} CC	-	-	150 ⁴⁾	μA	Standby RAM is active. Power to remaining domains switched off. $T_J = 25^\circ\text{C}$; $V_{EVRSB} = 5V$
Σ Sum of all currents (SLEEP mode)	I_{SLEEP} CC	-	-	10	mA	CPU is in idle, All peripherals in sleep, $f_{SRI/SPB} = 1\text{ MHz}$; $T_J = 55^\circ\text{C}$

Table 3-18 Power Supply (cont'd)

Parameter	Symbol	Values			Unit	Note / Test Condition
		Min.	Typ.	Max.		
Maximum power dissipation	PD CC	-	-	460	mW	valid for Feature Package L, LC, LP, S, and SP; max power pattern
		-	-	360 ⁵⁾	mW	valid for Feature Package L, LC, LP, S, and SP; real power pattern

- 1) It shall be ensured when using the SC DC DC EVR13 that the current is limited to the maximum value documented in the EVR section. EVR SRCSCDC Interrupt shall be kept active to indicate violations of max current and temperature shall be monitored to keep leakage current within limits.
- 2) Realistic Pflash read pattern with 50% Pflash bandwidth utilization and a code mix of 50% 0s and 50% 1s. Dynamic Flash Idle via FCON.IDLE is activated bringing a benefit of 4 mA. A decoupling capacitor of atleast 100nF is used. Dflash read current is also included. In TC23x, separate VDDFL3 pin is not available, so only the total VDDx3RAIL is measured and characterized.
- 3) The total current drawn from external regulator is estimated with 72% EVR13 SMPS regulator Efficiency. $I_{DDTOTDCX}$ is calculated from I_{DDTOT} using the scaled core current $[(I_{DD} \times V_{DD}) / (V_{in} \times \text{Efficiency})]$ and constitutes all other rail currents and I_{DDM} .
- 4) The current during STANDBY mode is drawn at V_{DDP3} supply pin. During RUN-STANDBY mode transition the current drawn at V_{DDP3} supply pin is less than 6mA.
- 5) Incase of EVR13 SCDCDC mode, 50 mW need to be additionally added for the real pattern usecase considering 72% SCDCDC efficiency. Incase of EVR13 LDO mode, 320 mW need to be additionally added to consider the pass device power drop out.

3.10.1 Calculating the 1.3 V Current Consumption

The current consumption of the 1.3 V rail compose out of two parts:

- Static current consumption
- Dynamic current consumption

The static current consumption is related to the device temperature T_J and the dynamic current consumption depends of the configured clocking frequencies and the software application executed. These two parts needs to be added in order to get the rail current consumption.

Valid for Feature Package L, LC, LP, S, and SP products:

$$I_0 = 1,2092 \left[\frac{\text{mA}}{\text{C}} \right] \times e^{0,01792 \times T_J[\text{C}]} \quad (3.2)$$

$$I_0 = 3,196 \left[\frac{\text{mA}}{\text{C}} \right] \times e^{0,01982 \times T_J[\text{C}]} \quad (3.3)$$

Function 2 defines the typical static current consumption and Function 3 defines the maximum static current consumption. Both functions are valid for $V_{DD} = 1.326 \text{ V}$.

3.11 Power-up and Power-down



Figure 3-2 Single Supply mode - 3.3 V single supply

3.11.1 Single Supply mode

3.3 V single supply mode. 1.3 V is generated internally by the EVR13 regulator.

- The rate at which current is drawn from the external regulator (dI_{EXT}/dt) is limited during the basic infrastructure and EVR13 regulator start-up phase (T_0 upto T_2) to a maximum of 100 mA/100 μ s. EVR13 is also robust against a voltage ramp-up starting from a residual voltage between 0 - 1 V. Start-up slew rates for supply rails should comply to datasheet values.
- Furthermore it is also ensured that the current drawn from the external regulator (dI_{EXT}/dt) is limited during the Firmware start-up phase (T_2 upto T_3) to a maximum of 100 mA/100 μ s.
- PORST is active/ asserted when either PORST (input) or PORST (output) is active/ asserted.
- PORST (input) active means that the reset is held active by external agents by pulling the PORST pin low. It is recommended to keep the PORST (input) asserted until the external supply is above the respective primary reset threshold.
- PORST (output) active means that μ C asserts the reset internally and drives the PORST pin low thus propagating the reset to external devices. The PORST (output) is asserted by the μ C when atleast one among the two supply domains (1.3 V or 3.3 V) violate their primary under-voltage reset thresholds. The PORST (output) is deasserted by the μ C when all supplies are above their primary reset thresholds and the basic supply and clock infrastructure is available.
- The power sequence as shown in [Figure 3-2](#) is enumerated below
 - T_1 refers to the point in time when basic supply and clock infrastructure is available as the external supply ramps up. The supply mode is evaluated based on the HWCFG[0,2] pins and consequently a soft start of EVR13 regulator is initiated.
 - T_2 refers to the point in time when all supplies are above their primary reset thresholds. EVR13 regulator has ramped up. PORST (output) is deasserted and HWCFG[3:5] pins are latched on PORST rising edge. Firmware execution is initiated.
 - T_3 refers to the point in time when Firmware execution is completed. User code execution starts with a default frequency of 100 MHz.
 - T_4 refers to the point in time during the Ramp-down phase when atleast one of the externally provided or generated supplies (1.3 V or 3.3 V) drop below their respective primary under-voltage reset thresholds.

Electrical Specification Power-up and Power-down

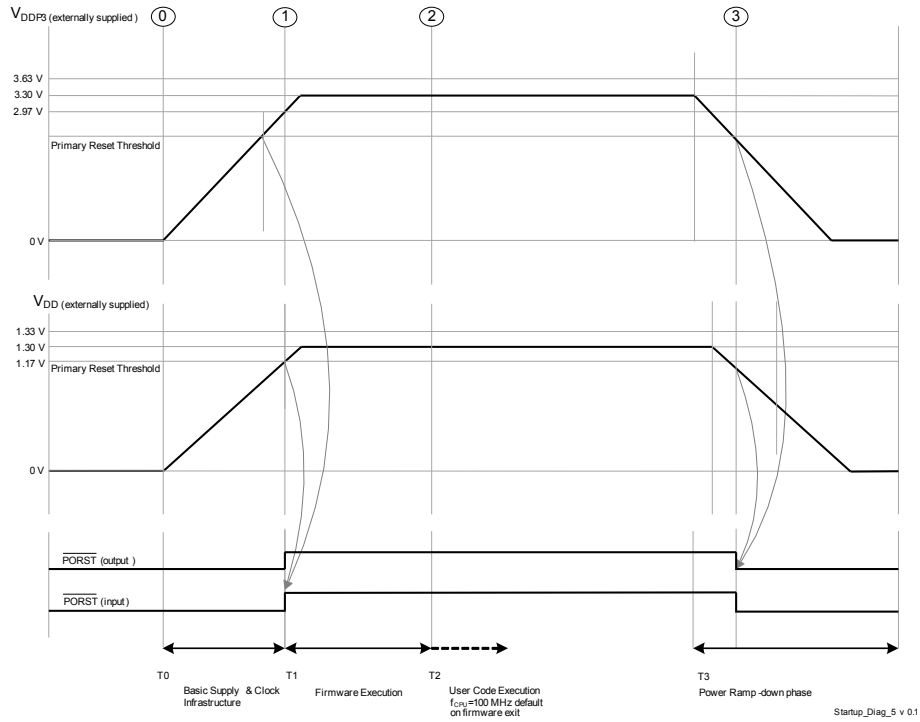

Figure 3-3 External Supply mode - 3.3 V and 1.3 V external supply

3.11.2 External Supply mode

All supplies, namely 3.3 V & 1.3 V, are externally supplied.

- External supplies VDDP3 & VDD may ramp-up or ramp-down independent of each other with regards to start, rise and fall time(s). The supply system is also robust against a voltage ramp-up starting from a residual voltage between 0 - 1 V. Start-up slew rates for supply rails should comply to datasheet values.
- The rate at which current is drawn from the external regulator (dI_{EXT}/dt , dI_{DD}/dt) is limited in the Start-up phase to a maximum of 50 mA/100 μ s.
- PORST is active/ asserted when either PORST (input) or PORST (output) is active/ asserted.
- PORST (input) active means that the reset is held active by external agents by pulling the PORST pin low. It is recommended to keep the PORST (input) asserted until all the external supplies are above their primary reset thresholds.
- PORST (output) active means that μ C asserts the reset internally and drives the PORST pin low thus propagating the reset to external devices. The PORST (output) is asserted by the μ C when atleast one among the two supply domains (1.3 V or 3.3 V) violate their primary under-voltage reset thresholds. The PORST (output) is deasserted by the μ C when all supplies are above their primary reset thresholds and the basic supply and clock infrastructure is available.
- The power sequence as shown in [Figure 3-3](#) is enumerated below
 - T1 refers to the point in time when all supplies are above their primary reset thresholds and basic clock infrastructure is available. The supply mode is evaluated based on the HWCFG[0,2] pins. PORST (output) is deasserted and HWCFG[3:5] pins are latched on PORST rising edge. Firmware execution is initiated.
 - T2 refers to the point in time when Firmware execution is completed. User code execution starts with a default frequency of 100 MHz.
 - T3 refers to the point in time during the Ramp-down phase when atleast one of the externally provided supplies (1.3 V or 3.3 V) drop below their respective primary under-voltage reset thresholds.

3.12 Reset Timing

Table 3-19 Reset Timings

Parameter	Symbol	Values			Unit	Note / Test Condition
		Min.	Typ.	Max.		
Application Reset Boot Time ¹⁾	t_B CC	-	-	350	μ s	operating with max. frequencies
System Reset Boot Time	t_{BS} CC	-	-	1	ms	
Power on Reset Boot Time ²⁾	t_{BP} CC	-	-	2.5	ms	$dV/dT=1V/ms$. including EVR ramp-up and Firmware execution time
		-	-	1.1	ms	Firmware execution time; without EVR operation (external supply only)
EVR start-up or ramp-up time	$t_{EVRstartup}$ CC	-	-	1	ms	$dV/dT=1V/ms$
Minimum PORST active hold time after power supplies are stable at operating levels ³⁾	t_{POA} CC	1	-	-	ms	
HWCFG pins hold time from ESR0 rising edge	t_{HDH} CC	$16 / f_{SPB}$	-	-	ns	
HWCFG pins setup time to ESR0 rising edge	t_{HDS} CC	0	-	-	ns	
Ports inactive after ESR0 reset active	t_{PI} CC	-	-	$8f_{SPB}$	ns	
Ports inactive after PORST reset active ⁴⁾	t_{PIP} CC	-	-	150	ns	
Hold time from PORST rising edge	t_{POH} SR	150	-	-	ns	
Setup time to PORST rising edge	t_{POS} SR	0	-	-	ns	

- 1) The duration of the boot time is defined between the rising edge of the internal application reset and the clock cycle when the first user instruction has entered the CPU pipeline and its processing starts.
- 2) The duration of the boot time is defined by all external supply voltages are inside there operation condicions and the clock cycle when the first user instruction has entered the CPU pipeline and its processing starts.
- 3) The regulator that supplies V_{EXT} should ensure that V_{EXT} is in the operational region before PORST is externally released by the regulator. Incase of 5V nominal supply, it should be ensured that $V_{EXT} > 4V$ before PORST is released. Incase of 3.3V nominal supply, it should be ensured that $V_{EXT} > 3V$ before PORST is released. The additional minimum PORST hold time is required as an additional mechanism to avoid consecutive PORST toggling owing to slow supply slopes or residual supply ramp-ups. It is also required to activate external PORST atleast 100us before power-fail is recognised to avoid consecutive PORST toggling on a power fail event.
- 4) This parameter includes the delay of the analog spike filter in the \overline{PORST} pad.

Electrical Specification Reset Timing

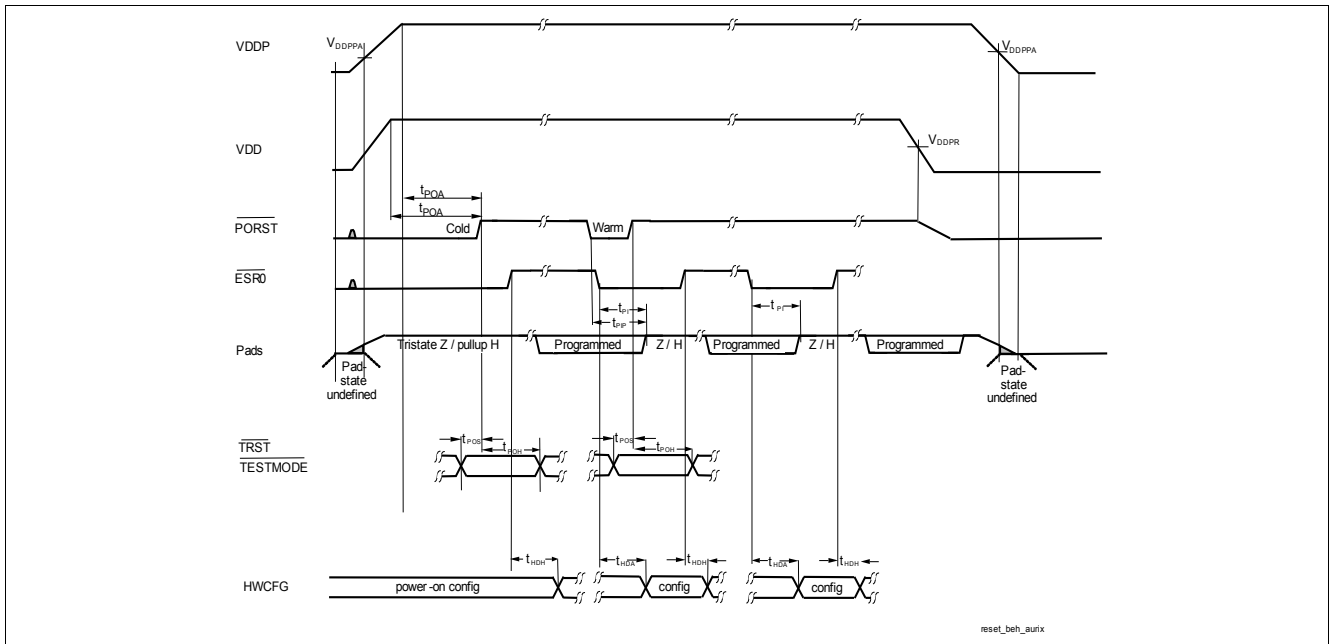

Figure 3-4 Power, Pad and Reset Timing

3.13 EVR

Table 3-20 LDO

Parameter	Symbol	Values			Unit	Note / Test Condition
		Min.	Typ.	Max.		
Input voltage range ¹⁾	V_{IN} SR	2.97	-	3.63	V	pass device=on chip
Output voltage operational range including load/line regulation and aging incase of LDO regulator	V_{OUT} CC	1.17	1.3	1.43	V	pass device=on chip
Output V_{DD} static voltage accuracy after trimming without dynamic load/line regulation with aging incase of LDO regulator.	V_{OUTT} CC	1.275	1.3	1.325	V	product load equal to I_{DD} of max power pattern; either $T_J \leq 150^\circ\text{C}$ and pass device=on chip or $T_J \leq 170^\circ\text{C}$ and pass device=off chip
Output buffer capacitance on V_{OUT} ²⁾	C_{OUT} CC	1.4	2.2	3	μF	On chip pass device usage restricted to $I_{DD} < 230\text{mA}$.; pass device=on chip
Primary undervoltage reset threshold for V_{DD} ³⁾	V_{RST13} CC	-	-	1.17 ⁴⁾	V	pass device=on chip
Startup time	t_{STR} CC	-	-	1000	μs	pass device=on chip
External V_{IN} supply ramp ⁵⁾	dV_{in}/dT SR	-	1	50	V/ms	pass device=on chip
Load step response	dV_{out}/dI_{out} CC	-	-	100	mV	$dI = -100\text{mA}$; $T_{settle} = 20\mu\text{s}$; pass device=on chip
		-100	-	-	mV	$dI = 75\text{mA}$; $T_{settle} = 20\mu\text{s}$; pass device=on chip
Line step response	dV_{out}/dV_{in} CC	-10	-	10	mV	$dV/dT = 1\text{V/ms}$; pass device=on chip

1) A maximum pass device dropout voltage of 700mV is included in the minimum input voltage to ensure optimal pass device operation.

2) It is recommended to select a capacitor with ESR less than 50 mOhm (0.5MHz - 10 MHz). It is also recommended that the resistance of the supply trace from the pin to the EVR output capacitor is less than 100 mOhm.

3) The reset release on supply ramp-up is delayed by a time duration 30-60 μs after reaching undervoltage reset threshold. This serves as a time hysteresis to avoid multiple consecutive cold PORST events during slow supply ramp-ups owing to voltage drop/current jumps when reset is released. The reset limit of 1,17V at pin is for the case with 1.3V generated internally from EVR13. In case the 1.3V supply is provided externally, the bondwire drop will cause a reset at a higher voltage of 1.18V at the VDD pin.

4) In TQFP-100 pin package, only $V_{DDPRIUV}$ is tested instead of VRST13 as HWCFG2 pin is absent.

5) EVR robust against residual voltage ramp-up starting between 0-1 V.

Table 3-21 Supply Monitoring

Parameter	Symbol	Values			Unit	Note / Test Condition
		Min.	Typ.	Max.		
V_{DDP3} primary undervoltage monitor accuracy after trimming ¹⁾	$V_{DDP3PRIUV}$ SR	2.86	2.92	2.97	V	
V_{DD} primary undervoltage monitor accuracy after trimming ¹⁾	$V_{DDPRIUV}$ SR	1.13	1.15	1.17	V	
V_{DDP3} secondary supply monitor accuracy	$V_{DDP3MON}$ CC	3.23	3.30	3.37	V	SWDxxVAL V_{DDP3} monitoring threshold=3.3V=91h
V_{DD} secondary supply monitor accuracy	V_{DDMON} CC	1.27	1.30	1.33	V	EVR13xxVAL V_{DD} monitoring threshold=1.3V=E4h
EVR primary and secondary monitor measurement latency for a new supply value	t_{EVRMON} CC	-	-	1.8	μ s	

1) The monitor tolerances constitute the inherent variation of the bandgap and ADC over process, voltage and temperature operational ranges. The xxxPRIUV parameters are device individually tested in production with $\pm 1\%$ tolerance about the min and max xxxPRIUV limits. In TQFP100 and QFP80 pin packages, VDDPRIUV is not tested as HWCFG2 pin is absent.

Table 3-22 EVR13 SMPS

Parameter	Symbol	Values			Unit	Note / Test Condition
		Min.	Typ.	Max.		
Input V_{DDP3} voltage range	V_{IN} CC	2.97	-	3.63	V	
SMPS regulator output voltage range including load/line regulation and aging ¹⁾	V_{DDDC} CC	-	-	1.43	V	$V_{DDP3} > 2.97V$; $I_{DDDC} < 200mA$; $f_{DCDC} = 1MHz$
		1.17	-	-	V	$V_{DDP3} > 2.97V$; $I_{DDDC} < 250mA$; $f_{DCDC} = 1MHz$
SMPS regulator static voltage output accuracy after trimming without dynamic load/line Regulation with aging. ²⁾	V_{DDDC} CC	1.275	1.3	1.325	V	$V_{DDP3} > 2.97V$; $I_{DDDC} < 230mA$; $f_{DCDC} = 1MHz$
Programmable switching frequency	f_{DCDC} CC	0.4	-	2.0	MHz	
Maximum ripple at I_{MAX} (peak-to-peak) ³⁾	ΔV_{DDDC} CC	-	-	26	mV	$V_{DDP3} > 2.97V$; $I_{DDDC} < 230mA$; $f_{DCDC} = 1MHz$
SMPS regulator load transient response	dV_{out}/dI_{out} CC	-90	-	90	mV	$dI < 100mA$; $f_{DCDC}=1MHz$; $t_f=0.1\mu s$; $t_r=0.1\mu s$; $V_{DDDC}=1.3V$

Table 3-22 EVR13 SMPS (cont'd)

Parameter	Symbol	Values			Unit	Note / Test Condition
		Min.	Typ.	Max.		
Maximum output current of the regulator	I_{MAX} SR	-	-	250 ⁴⁾	mA	$V_{DDP3} > 2.97V$; $V_{DD} = 1.17V$; $f_{DCDC} = 1MHz$
SMPS regulator efficiency	η_{DC} CC	-	72	-	%	$V_{IN} = 3.3V$; $I_{DDDC} = 200mA$; $f_{DCDC} = 1MHz$

- 1) In case of SMPS mode, it shall be ensured that the V_{DD} output pin shall be connected on PCB level to all other V_{DD} Input pins.
- 2) In case of f_{SRI} running with max frequency, it shall be ensured that the V_{DD} operating range is limited to 1.235V upto 1.430V. The DCDC may be configured in this case with a nominal voltage of $1.33V \pm 7.5\%$. The static accuracy and regulation parameter ranges remain also valid for this case.
- 3) If frequency spreading (SDFREQSPRD = 1) is activated, an additional ripple of 1% need to be considered.
- 4) It shall be ensured when using the SC DC DC EVR13 that the current is limited to the maximum value. EVR SRCSCDC Interrupt shall be kept active to indicate violations of max current and temperature shall be monitored to keep leakage current within limits.

Table 3-23 EVR13 SMPS External components

Parameter	Symbol	Values			Unit	Note / Test Condition
		Min.	Typ.	Max.		
External output capacitor value ¹⁾	C_{OUTDC} SR	6.5	10	13.5	μF	$I_{DDDC} = 230mA$
External output capacitor ESR	C_{DC_ESR} SR	-	-	50	mOhm	$f \geq 0.5MHz$; $f \leq 10MHz$
		-	-	100	Ohm	$f = 10Hz$
External input capacitor value ¹⁾	C_{IN} SR	3.29	4.7	6.11	μF	$I_{DDDC} = 230mA$
External input capacitor ESR	C_{IN_ESR} SR	-	-	50	mOhm	$f \geq 0.5MHz$; $f \leq 10MHz$
		-	-	100	Ohm	$f = 100Hz$
External flying capacitor value ¹⁾	C_{FLY} SR	0.7	1 ²⁾	1.3	μF	$I_{DDDC} = 230mA$
Flying capacitor ESR	C_{FLY_ESR} SR	-	-	50	mOhm	$f \geq 0.5MHz$; $f \leq 10MHz$
		-	-	100	Ohm	$f = 100Hz$

- 1) Capacitor min-max range represent typical $\pm 35\%$ tolerance including DC bias effect. The trace resistance from the capacitor to the supply or ground rail should be limited to 25 mOhm.
- 2) It is recommended to place the flying capacitor close to the pins without vias to have minimal routing resistance from pin to the capacitor terminal of less than 25mOhm.

3.14 Phase Locked Loop (PLL)

Table 3-24 PLL

Parameter	Symbol	Values			Unit	Note / Test Condition
		Min.	Typ.	Max.		
PLL base frequency	f_{PLLBASE} CC	80	150	360	MHz	
VCO frequency range	f_{VCO} SR	400	-	800	MHz	
VCO Input frequency range	f_{REF} CC	8	-	24	MHz	
Modulation Amplitude	MA CC	0	-	2	%	
Peak Period jitter	DP CC	-200	-	200	ps	
Peak Accumulated Jitter	D_{PP} CC	-5	-	5	ns	without modulation
Total long term jitter	J_{TOT} CC	-	-	12.2	ns	including modulation; MA ≤ 1%
		-	-	11.5	ns	including modulation; MA ≤ 0.9%
System frequency deviation	f_{SYSD} CC	-	-	0.01	%	with active modulation
Modulation variation frequency	f_{MV} CC	2	3.6	5.4	MHz	
PLL lock-in time	t_{L} CC	11.5	-	200	μs	

Note: The specified PLL jitter values are valid if the capacitive load per pin does not exceed $C_L = 20$ pF with the maximum driver and soft edge (speed grade 1).

Note: The maximum peak-to-peak noise on the power supply voltage, is limited to a peak-to-peak voltage of $V_{\text{PP}} = 100$ mV for noise frequencies below 300 KHz and $V_{\text{PP}} = 40$ mV for noise frequencies above 300 KHz. These conditions can be achieved by appropriate blocking of the supply voltage as near as possible to the supply pins and using PCB supply and ground planes.

3.15 ERAY Phase Locked Loop (ERAY_PLL)

Table 3-25 PLL_ERAY

Parameter	Symbol	Values			Unit	Note / Test Condition
		Min.	Typ.	Max.		
PLL Base Frequency of the ERAY PLL	$f_{\text{PLLBASE_ERAY CC}}$	50	200	320	MHz	
VCO frequency range of the ERAY PLL	$f_{\text{VCO_ERAY SR}}$	400	-	480	MHz	
VCO input frequency of the ERAY PLL	$f_{\text{REF SR}}$	16	-	24	MHz	
Accumulated_Jitter	$D_{\text{p CC}}$	-0.5	-	0.5	ns	
Accumulated jitter at SYSCLK pin	$D_{\text{pp CC}}$	-0.8	-	0.8	ns	
PLL lock-in time	$t_{\text{L CC}}$	5.6	-	200	μs	

Note: The specified PLL jitter values are valid if the capacitive load per pin does not exceed $C_L = 20 \text{ pF}$ with the maximum driver and soft edge (speed grade 1).

Note: The maximum peak-to-peak noise on the power supply voltage, is limited to a peak-to-peak voltage of $V_{\text{pp}} = 100 \text{ mV}$ for noise frequencies below 300 KHz and $V_{\text{pp}} = 40 \text{ mV}$ for noise frequencies above 300 KHz. These conditions can be achieved by appropriate blocking of the supply voltage as near as possible to the supply pins and using PCB supply and ground planes.

3.16 AC Specifications

All AC parameters are specified for the complete operating range defined in [Chapter 3.4](#) unless otherwise noted in column Note / test Condition.

Unless otherwise noted in the figures the timings are defined with the following guidelines:



Figure 3-5 Definition of rise / fall times



Figure 3-6 Time Reference Point Definition

3.17 JTAG Parameters

The following parameters are applicable for communication through the JTAG debug interface. The JTAG module is fully compliant with IEEE1149.1-2000.

Table 3-26 JTAG

Parameter	Symbol	Values			Unit	Note / Test Condition
		Min.	Typ.	Max.		
TCK clock period	t_1 SR	25	-	-	ns	
TCK high time	t_2 SR	10	-	-	ns	
TCK low time	t_3 SR	10	-	-	ns	
TCK clock rise time	t_4 SR	-	-	4	ns	
TCK clock fall time	t_5 SR	-	-	4	ns	
TDI/TMS setup to TCK rising edge	t_6 SR	6.0	-	-	ns	
TDI/TMS hold after TCK rising edge	t_7 SR	6.0	-	-	ns	
TDO valid after TCK falling edge (propagation delay) ¹⁾	t_8 CC	3.0	-	-	ns	$C_L \leq 20\text{pF}$
		-	-	16	ns	$C_L \leq 50\text{pF}$
TDO hold after TCK falling edge ¹⁾	t_{18} CC	2	-	-	ns	
TDO high impedance to valid from TCK falling edge ¹⁾²⁾	t_9 CC	-	-	14	ns	$C_L \leq 50\text{pF}$
TDO valid output to high impedance from TCK falling edge ¹⁾	t_{10} CC	-	-	13.5	ns	$C_L \leq 50\text{pF}$

1) The falling edge on TCK is used to generate the TDO timing.

2) The setup time for TDO is given implicitly by the TCK cycle time.



Figure 3-7 Test Clock Timing (TCK)

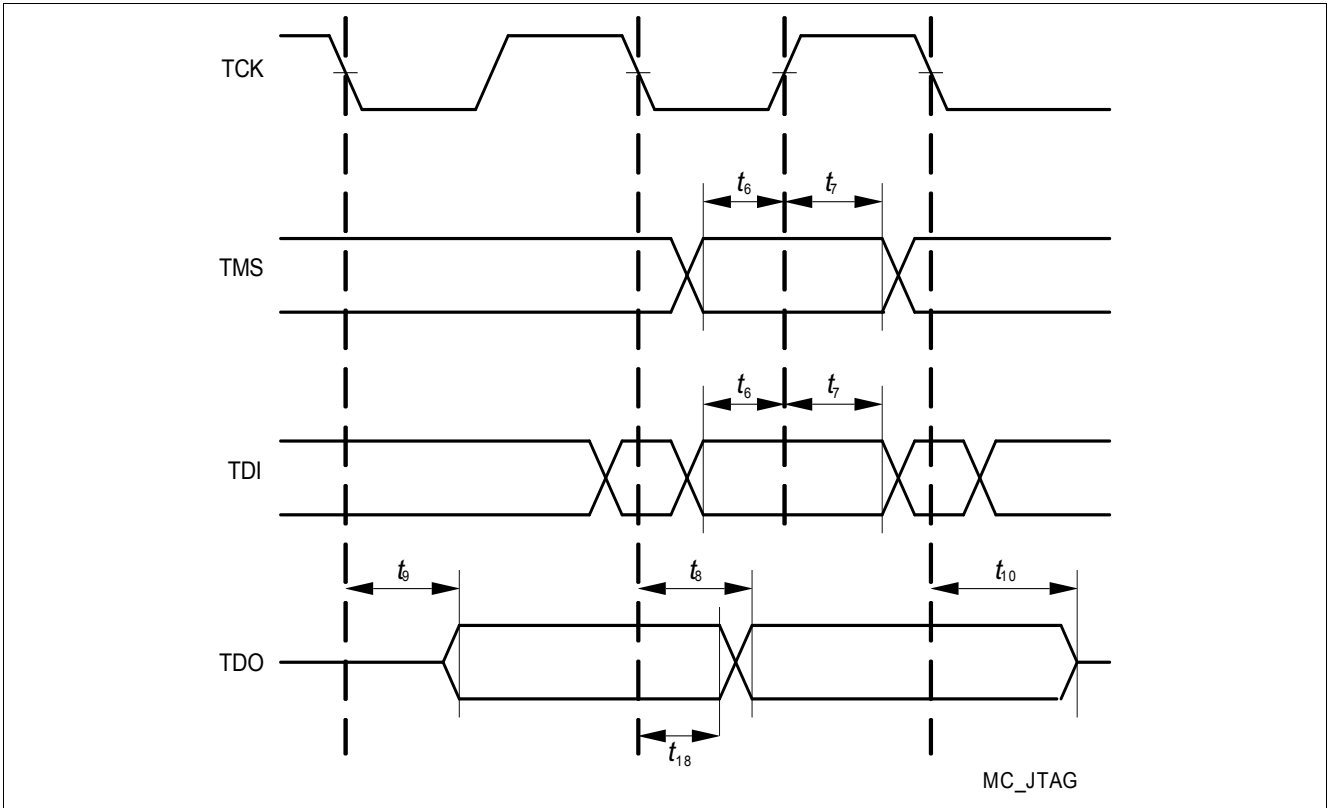

Figure 3-8 JTAG Timing

3.18 DAP Parameters

The following parameters are applicable for communication through the DAP debug interface.

Table 3-27 DAP

Parameter	Symbol	Values			Unit	Note / Test Condition
		Min.	Typ.	Max.		
DAP0 clock period	t_{11} SR	6.25	-	-	ns	
DAP0 high time	t_{12} SR	2	-	-	ns	
DAP0 low time	t_{13} SR	2	-	-	ns	
DAP0 clock rise time	t_{14} SR	-	-	1	ns	$f=160\text{MHz}$
		-	-	2	ns	$f=80\text{MHz}$
DAP0 clock fall time	t_{15} SR	-	-	1	ns	$f=160\text{MHz}$
		-	-	2	ns	$f=80\text{MHz}$
DAP1 setup to DAP0 rising edge	t_{16} SR	4	-	-	ns	
DAP1 hold after DAP0 rising edge	t_{17} SR	2	-	-	ns	
DAP1 valid per DAP0 clock period ¹⁾	t_{19} CC	3	-	-	ns	$C_L=20\text{pF}; f=160\text{MHz}$
		8	-	-	ns	$C_L=20\text{pF}; f=80\text{MHz}$
		10	-	-	ns	$C_L=50\text{pF}; f=40\text{MHz}$

1) The Host has to find a suitable sampling point by analyzing the sync telegram response.

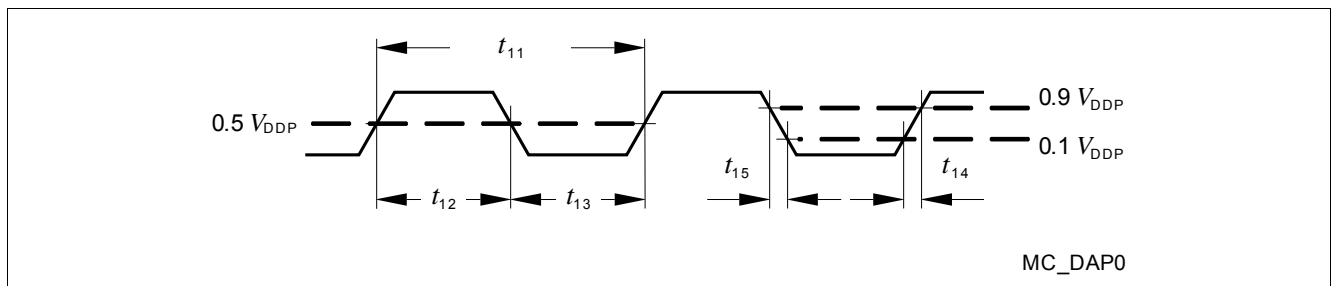

Figure 3-9 Test Clock Timing (DAP0)

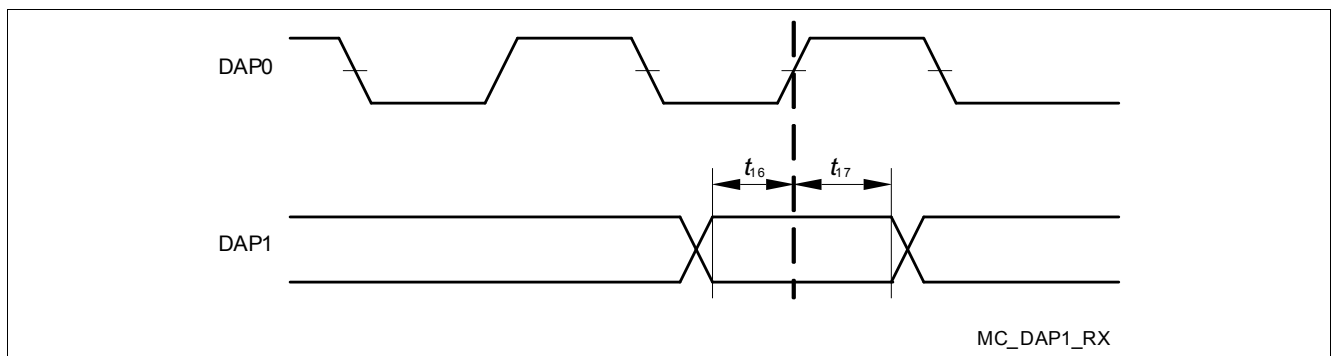

Figure 3-10 DAP Timing Host to Device



Figure 3-11 DAP Timing Device to Host (DAP1 and DAP2 pins)

Note: The DAP1 and DAP2 device to host timing is individual for both pins. There is no guaranteed max. signal skew.

3.19 ASCLIN SPI Master Timing

This section defines the timings for the ASCLIN in the TC233 / TC234 / TC237.

Table 3-28 Master Mode A1+strong soft (sf) output pads

Parameter	Symbol	Values			Unit	Note / Test Condition
		Min.	Typ.	Max.		
ASCLKO clock period ¹⁾	t_{50} CC	20	-	-	ns	$C_L=25\text{pF}$
Deviation from ideal duty cycle ²⁾	t_{500} CC	-3	-	3	ns	$C_L=25\text{pF}$
MTR delay from ASCLKO shifting edge	t_{51} CC	-4	-	4	ns	$C_L=25\text{pF}$
ASLSON delay from the first ASCLKO edge	t_{510} CC	-4	-	4	ns	$C_L=25\text{pF}$
MRST setup to ASCLKO latching edge	t_{52} SR	20	-	-	ns	$C_L=25\text{pF}$
MRST hold from ASCLKO latching edge	t_{53} SR	-3	-	-	ns	$C_L=25\text{pF}$

- 1) PLL Jitter not included. Should be considered additionally, corresponding to the used baudrate. The duty cycle can be adjusted using the BITCON.SAMPLEPOINT bitfield with the finest granularity of $T_{MAX} = 1 / f_{MAX}$.
- 2) Positive deviation lengthens the high time and shortens the low time of a clock period. Negative deviation does the opposite.

Table 3-29 Master Mode A1+strong slow (sw) output pads

Parameter	Symbol	Values			Unit	Note / Test Condition
		Min.	Typ.	Max.		
ASCLKO clock period ¹⁾	t_{50} CC	80	-	-	ns	$C_L=50\text{pF}$
Deviation from ideal duty cycle ²⁾	t_{500} CC	-8	-	8	ns	$C_L=50\text{pF}$
MTR delay from ASCLKO shifting edge	t_{51} CC	-12	-	12	ns	$C_L=50\text{pF}$
ASLSON delay from the first ASCLKO edge	t_{510} CC	-12	-	12	ns	$C_L=50\text{pF}$
MRST setup to ASCLKO latching edge	t_{52} SR	40	-	-	ns	$C_L=50\text{pF}$
MRST hold from ASCLKO latching edge	t_{53} SR	-3	-	-	ns	$C_L=50\text{pF}$

- 1) PLL Jitter not included. Should be considered additionally, corresponding to the used baudrate. The duty cycle can be adjusted using the BITCON.SAMPLEPOINT bitfield with the finest granularity of $T_{MAX} = 1 / f_{MAX}$.
- 2) Positive deviation lengthens the high time and shortens the low time of a clock period. Negative deviation does the opposite.

Electrical Specification ASCLIN SPI Master Timing

Table 3-30 Master Mode medium output pads

Parameter	Symbol	Values			Unit	Note / Test Condition
		Min.	Typ.	Max.		
ASCLKO clock period ¹⁾	t_{50} CC	100	-	-	ns	$C_L=50\text{pF}$
Deviation from ideal duty cycle ²⁾	t_{500} CC	-10	-	10	ns	$C_L=50\text{pF}$
MTSR delay from ASCLKO shifting edge	t_{51} CC	-15	-	15	ns	$C_L=50\text{pF}$
ASLSON delay from the first ASCLKO edge	t_{510} CC	-15	-	15	ns	$C_L=50\text{pF}$
MRST setup to ASCLKO latching edge	t_{52} SR	50	-	-	ns	$C_L=50\text{pF}$
MRST hold from ASCLKO latching edge	t_{53} SR	-5	-	-	ns	$C_L=50\text{pF}$

- 1) PLL Jitter not included. Should be considered additionally, corresponding to the used baudrate. The duty cycle can be adjusted using the BITCON.SAMPLEPOINT bitfield with the finest granularity of $T_{MAX} = 1 / f_{MAX}$.
- 2) Positive deviation lengthens the high time and shortens the low time of a clock period. Negative deviation does the opposite.

Table 3-31 Master Mode weak output pads

Parameter	Symbol	Values			Unit	Note / Test Condition
		Min.	Typ.	Max.		
ASCLKO clock period ¹⁾	t_{50} CC	1000	-	-	ns	$C_L=50\text{pF}$
Deviation from ideal duty cycle ²⁾	t_{500} CC	-25	-	25	ns	$C_L=50\text{pF}$
MTSR delay from ASCLKO shifting edge	t_{51} CC	-65	-	65	ns	$C_L=50\text{pF}$
ASLSON delay from the first ASCLKO edge	t_{510} CC	-65	-	65	ns	$C_L=50\text{pF}$
MRST setup to ASCLKO latching edge	t_{52} SR	150	-	-	ns	$C_L=50\text{pF}$
MRST hold from ASCLKO latching edge	t_{53} SR	-10	-	-	ns	$C_L=50\text{pF}$

- 1) PLL Jitter not included. Should be considered additionally, corresponding to the used baudrate. The duty cycle can be adjusted using the BITCON.SAMPLEPOINT bitfield with the finest granularity of $T_{MAX} = 1 / f_{MAX}$.
- 2) Positive deviation lengthens the high time and shortens the low time of a clock period. Negative deviation does the opposite.



Figure 3-12 ASCLIN SPI Master Timing

3.20 QSPI Timings, Master and Slave Mode

This section defines the timings for the QSPI in the TC233 / TC234 / TC237.

It is assumed that SCLKO, MTSR, and SLSO pads have the same pad settings:

Table 3-32 Master Mode timing A1+ strong soft (sf) output pads

Parameter	Symbol	Values			Unit	Note / Test Condition
		Min.	Typ.	Max.		
SCLKO clock period ¹⁾	t_{50} CC	20	-	-	ns	$C_L=25\text{pF}$
Deviation from the ideal duty cycle ^{2) 3)}	t_{500} CC	-3	-	3	ns	$C_L=25\text{pF}$
MTSR delay from SCLKO shifting edge	t_{51} CC	-4	-	4	ns	$C_L=25\text{pF}$
SLSO deviation from the ideal programmed position	t_{510} CC	-4	-	4	ns	$C_L=25\text{pF}$
MRST setup to SCLK latching edge ⁴⁾	t_{52} SR	20 ⁴⁾	-	-	ns	$C_L=25\text{pF}$
MRST hold from SCLK latching edge	t_{53} SR	-3 ⁴⁾	-	-	ns	$C_L=25\text{pF}$

1) Documented value is valid for master transmit or slave receive only. For full duplex the external SPI counterpart timing has to be taken into account.

2) The PLL jitter is not included. It should be considered additionally, corresponding to the used baudrate. The duty cycle can be adjusted using the bit fields ECONz.A, B and C with the finest granularity of $T_{MAX} = 1 / f_{MAX}$.

3) Positive deviation lengthens the high time and shortens the low time of a clock period. Negative deviation does the opposite.

4) For compensation of the average on-chip delay the QSPI module provides the bit fields ECONz.A, B and C.

Electrical Specification QSPI Timings, Master and Slave Mode

Table 3-33 Master Mode timing A1+ strong slow (sw) output pads

Parameter	Symbol	Values			Unit	Note / Test Condition
		Min.	Typ.	Max.		
SCLKO clock period ¹⁾	t_{50} CC	80	-	-	ns	$C_L=50\text{pF}$
Deviation from the ideal duty cycle ^{2) 3)}	t_{500} CC	-8	-	8	ns	$C_L=50\text{pF}$
MISR delay from SCLKO shifting edge	t_{51} CC	-12	-	12	ns	$C_L=50\text{pF}$
SLSON deviation from the ideal programmed position	t_{510} CC	-12	-	12	ns	$C_L=50\text{pF}$
MRST setup to SCLK latching edge ⁴⁾	t_{52} SR	40 ⁴⁾	-	-	ns	$C_L=50\text{pF}$
MRST hold from SCLK latching edge	t_{53} SR	-3	-	-	ns	$C_L=50\text{pF}$

- 1) Documented value is valid for master transmit or slave receive only. For full duplex the external SPI counterpart timing has to be taken into account.
- 2) The PLL jitter is not included. It should be considered additionally, corresponding to the used baudrate. The duty cycle can be adjusted using the bit fields ECONz.A, B and C with the finest granularity of $T_{MAX} = 1 / f_{MAX}$.
- 3) Positive deviation lengthens the high time and shortens the low time of a clock period. Negative deviation does the opposite.
- 4) For compensation of the average on-chip delay the QSPI module provides the bit fields ECONz.A, B and C.

Table 3-34 Master Mode timing A1+m/A1m output pads

Parameter	Symbol	Values			Unit	Note / Test Condition
		Min.	Typ.	Max.		
SCLKO clock period ¹⁾	t_{50} CC	100	-	-	ns	$C_L=50\text{pF}$
Deviation from the ideal duty cycle ^{2) 3)}	t_{500} CC	-3	-	3	ns	$C_L=50\text{pF}$
MISR delay from SCLKO shifting edge	t_{51} CC	-8	-	8	ns	$C_L=50\text{pF}$
SLSON deviation from the ideal programmed position	t_{510} CC	-15	-	15	ns	$C_L=50\text{pF}$
MRST setup to SCLK latching edge ⁴⁾	t_{52} SR	50 ⁴⁾	-	-	ns	$C_L=50\text{pF}$
MRST hold from SCLK latching edge	t_{53} SR	-5 ⁴⁾	-	-	ns	$C_L=50\text{pF}$

- 1) Documented value is valid for master transmit or slave receive only. For full duplex the external SPI counterpart timing has to be taken into account.
- 2) The PLL jitter is not included. It should be considered additionally, corresponding to the used baudrate. The duty cycle can be adjusted using the bit fields ECONz.A, B and C with the finest granularity of $T_{MAX} = 1 / f_{MAX}$.
- 3) Positive deviation lengthens the high time and shortens the low time of a clock period. Negative deviation does the opposite.
- 4) For compensation of the average on-chip delay the QSPI module provides the bit fields ECONz.A, B and C.

Electrical Specification QSPI Timings, Master and Slave Mode

Table 3-35 Master Mode Weak output pads

Parameter	Symbol	Values			Unit	Note / Test Condition
		Min.	Typ.	Max.		
SCLKO clock period ¹⁾	t_{50} CC	1000	-	-	ns	$C_L=50\text{pF}$
Deviation from the ideal duty cycle ^{2) 3)}	t_{500} CC	-25	-	25	ns	$C_L=50\text{pF}$
MTSR delay from SCLKO shifting edge	t_{51} CC	-65	-	65	ns	$C_L=50\text{pF}$
SLSOn deviation from the ideal programmed position	t_{510} CC	-65	-	65	ns	$C_L=50\text{pF}$
MRST setup to SCLK latching edge ⁴⁾	t_{52} SR	150 ⁴⁾	-	-	ns	$C_L=50\text{pF}$
MRST hold from SCLK latching edge	t_{53} SR	-10 ⁴⁾	-	-	ns	$C_L=50\text{pF}$

- 1) Documented value is valid for master transmit or slave receive only. For full duplex the external SPI counterpart timing has to be taken into account.
- 2) The PLL jitter is not included. It should be considered additionally, corresponding to the used baudrate. The duty cycle can be adjusted using the bit fields ECONz.A, B and C with the finest granularity of $T_{MAX} = 1 / f_{MAX}$.
- 3) Positive deviation lengthens the high time and shortens the low time of a clock period. Negative deviation does the opposite.
- 4) For compensation of the average on-chip delay the QSPI module provides the bit fields ECONz.A, B and C.

Table 3-36 Slave mode timing

Parameter	Symbol	Values			Unit	Note / Test Condition
		Min.	Typ.	Max.		
SCLK clock period	t_{54} SR	$4 \times T_{MAX}$	-	-	ns	
SCLK duty cycle	$t_{55/t54}$ SR	40	-	60	%	
MTSR setup to SCLK latching edge	t_{56} SR	3	-	-	ns	
MTSR hold from SCLK latching edge	t_{57} SR	3	-	-	ns	
SLSI setup to first SCLK shift edge	t_{58} SR	3	-	-	ns	
SLSI hold from last SCLK latching edge	t_{59} SR	3	-	-	ns	
MRST delay from SCLK shift edge	t_{60} CC	5	-	50	ns	A1+m/A1m; $C_L=50\text{pF}$
		3	-	20	ns	A1+sf; $C_L=25\text{pF}$
		5	-	40	ns	A1+sw; $C_L=50\text{pF}$
		10	-	150	ns	A1+w/A1w; $C_L=50\text{pF}$
SLSI to valid data on MRST	t_{61} SR	-	-	9	ns	

Electrical Specification QSPI Timings, Master and Slave Mode

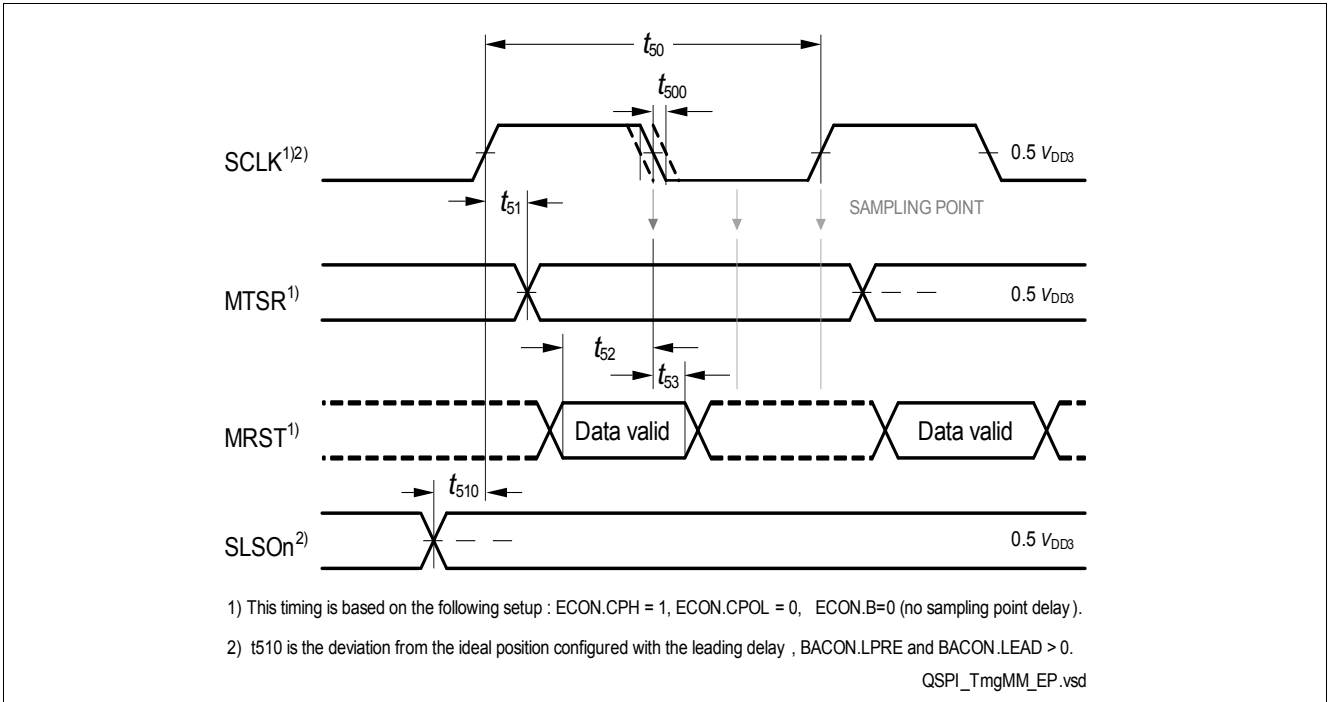

Figure 3-13 Master Mode Timing



Figure 3-14 Slave Mode Timing

3.21 Ethernet Interface (ETH) Characteristics

3.21.1 ETH Measurement Reference Points

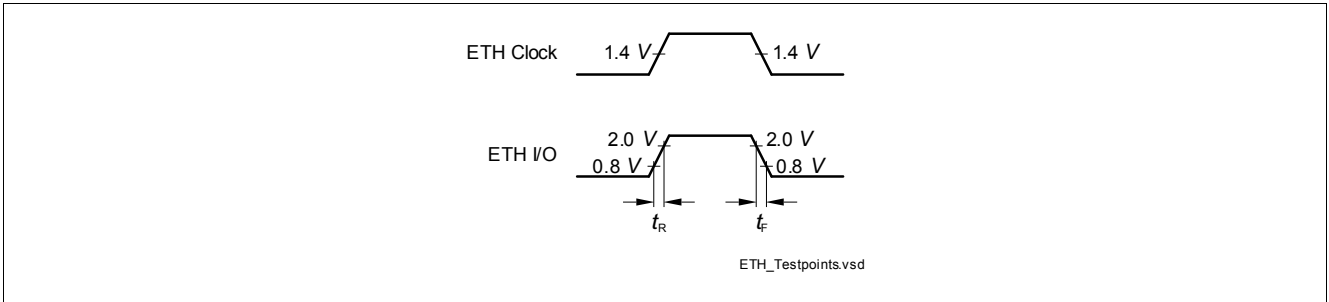

Figure 3-15 ETH Measurement Reference Points

3.21.2 ETH Management Signal Parameters (ETH_MDC, ETH_MDIO)

Table 3-37 ETH Management Signal Parameters

Parameter	Symbol	Values			Unit	Note / Test Condition
		Min.	Typ.	Max.		
ETH_MDC period	t_1 CC	400	-	-	ns	$C_L=25\text{pF}$
ETH_MDC high time	t_2 CC	160	-	-	ns	$C_L=25\text{pF}$
ETH_MDC low time	t_3 CC	160	-	-	ns	$C_L=25\text{pF}$
ETH_MDIO setup time (output)	t_4 CC	10	-	-	ns	$C_L=25\text{pF}$
ETH_MDIO hold time (output)	t_5 CC	10	-	-	ns	$C_L=25\text{pF}$
ETH_MDIO data valid (input)	t_6 SR	0	-	300	ns	$C_L=25\text{pF}$

Figure 3-16 ETH Management Signal Timing

Electrical Specification Ethernet Interface (ETH) Characteristics

3.21.3 ETH MII Parameters

In the following, the parameters of the MII (Media Independent Interface) are described.

Table 3-38 ETH MII Signal Timing Parameters

Parameter	Symbol	Values			Unit	Note / Test Condition
		Min.	Typ.	Max.		
Clock period	t_7 SR	40	-	-	ns	$C_L=25\text{pF}$; baudrate=100Mbps
		400	-	-	ns	$C_L=25\text{pF}$; baudrate=10Mbps
Clock high time	t_8 SR	14	-	26	ns	$C_L=25\text{pF}$; baudrate=100Mbps
		140 ¹⁾	-	260 ²⁾	ns	$C_L=25\text{pF}$; baudrate=10Mbps
Clock low time	t_9 SR	14	-	26	ns	$C_L=25\text{pF}$; baudrate=100Mbps
		140 ¹⁾	-	260 ²⁾	ns	$C_L=25\text{pF}$; baudrate=10Mbps
Input setup time	t_{10} SR	10	-	-	ns	$C_L=25\text{pF}$
Input hold time	t_{11} SR	10	-	-	ns	$C_L=25\text{pF}$
Output valid time	t_{12} CC	0	-	25	ns	$C_L=25\text{pF}$

1) Defined by 35% of clock period.

2) Defined by 65% of clock period.

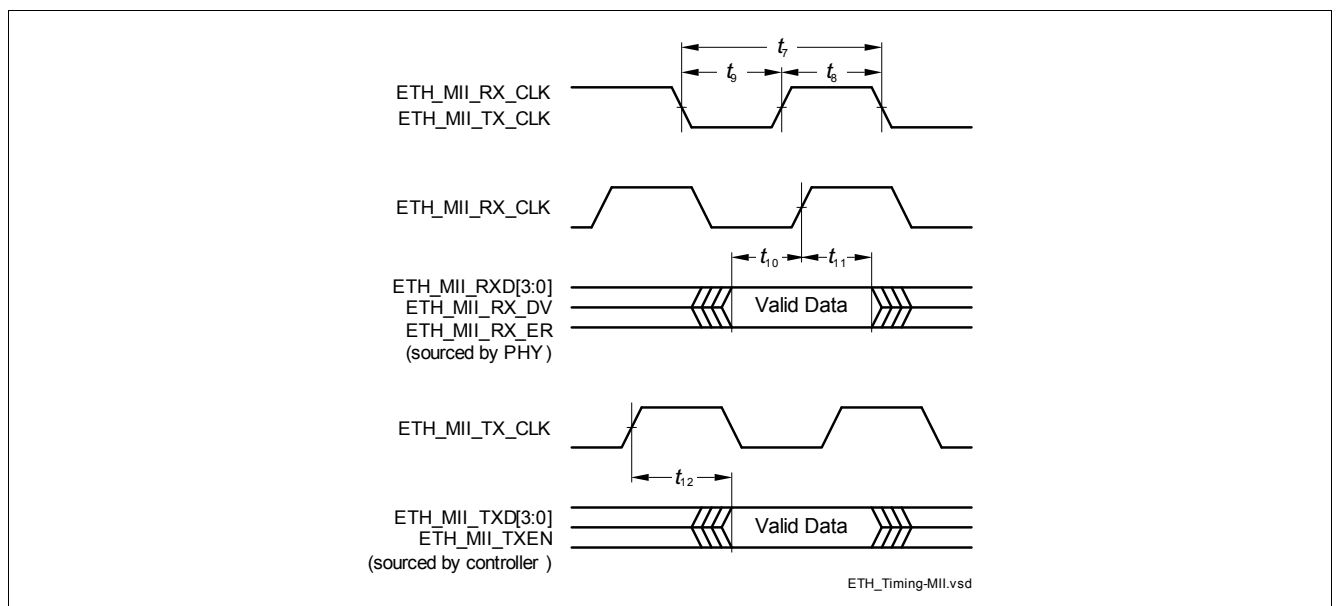

Figure 3-17 ETH MII Signal Timing

3.21.4 ETH RMII Parameters

In the following, the parameters of the RMII (Reduced Media Independent Interface) are described.

Table 3-39 ETH RMII Signal Timing Parameters

Parameter	Symbol	Values			Unit	Note / Test Condition
		Min.	Typ.	Max.		
ETH_RMII_REF_CL clock period	t_{13} CC	20	-	-	ns	$C_L=25\text{pF}$; 50ppm
ETH_RMII_REF_CL clock high time	t_{14} CC	7 ¹⁾	-	13 ²⁾	ns	$C_L=25\text{pF}$
ETH_RMII_REF_CL clock low time	t_{15} CC	7 ¹⁾	-	13 ²⁾	ns	$C_L=25\text{pF}$
ETHTXEN, ETHTXD[1:0], ETHRXD[1:0], ETHCRSDV, ETHRXER; setup time	t_{16} CC	4	-	-	ns	$C_L=25\text{pF}$
ETHTXEN, ETHTXD[1:0], ETHRXD[1:0], ETHCRSDV, ETHRXER; hold time	t_{17} CC	2	-	-	ns	$C_L=25\text{pF}$

1) Defined by 35% of clock period.

2) Defined by 65% of clock period.

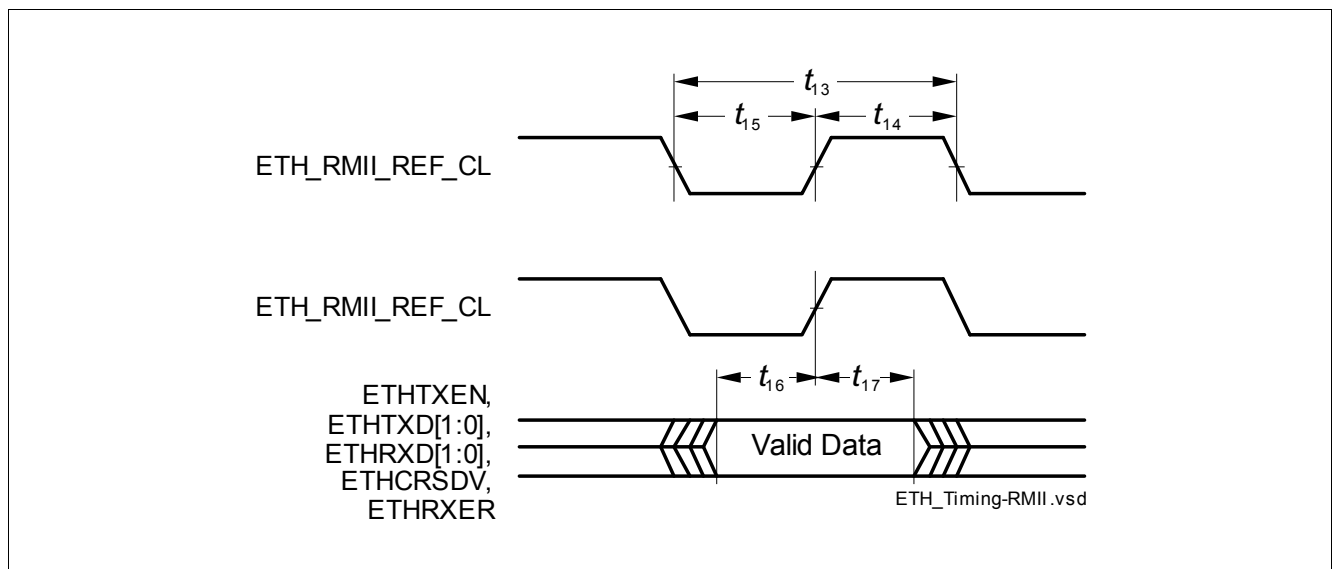

Figure 3-18 ETH RMII Signal Timing

3.22 E-Ray Parameters

The timings of this section are valid for the strong driver and sharp edge settings of the output drivers with $C_L = 25$ pF.

Table 3-40 Transmit Parameters

Parameter	Symbol	Values			Unit	Note / Test Condition
		Min.	Typ.	Max.		
Rise time of TxEN	$t_{dCCTxENRise25CC}$	-	-	9	ns	$C_L=25pF$
Fall time of TxEN	$t_{dCCTxENFall25CC}$	-	-	9	ns	$C_L=25pF$
Sum of rise and fall time	$t_{dCCTxRise25+dCCTxFall25CC}$	-	-	9	ns	20% - 80%; $C_L=25pF$
Sum of delay between TP1_FF and TP1_CC and delays derived from TP1_FFi, rising edge of TxEN	$t_{dCCTxEN01CC}$	-	-	25	ns	
Sum of delay between TP1_FF and TP1_CC and delays derived from TP1_FFi, falling edge of TxEN	$t_{dCCTxEN10CC}$	-	-	25	ns	
Asymmetry of sending	$t_{tx_asym} CC$	-2.45	-	2.45	ns	$C_L=25pF$
Sum of delay between TP1_FF and TP1_CC and delays derived from TP1_FFi, rising edge of TxD	$t_{dCCTxD01CC}$	-	-	25	ns	
Sum of delay between TP1_FF and TP1_CC and delays derived from TP1_FFi, falling edge of TxD	$t_{dCCTxD10CC}$	-	-	25	ns	
TxD signal sum of rise and fall time at TP1_BD	$t_{txd_sum} CC$	-	-	9	ns	

Table 3-41 Receive Parameters

Parameter	Symbol	Values			Unit	Note / Test Condition
		Min.	Typ.	Max.		
Acceptance of asymmetry at receiving part	$t_{dCCTxAsymAccept25SR}$	-30.5	-	43.0	ns	$C_L=25pF$
Acceptance of asymmetry at receiving part	$t_{dCCTxAsymAccept15SR}$	-31.5	-	44.0	ns	$C_L=15pF$
Threshold for detecting logical high	$T_{uCCLogic1SR}$	35	-	70	%	
Threshold for detecting logical low	$T_{uCCLogic0SR}$	30	-	65	%	

Table 3-41 Receive Parameters (cont'd)

Parameter	Symbol	Values			Unit	Note / Test Condition
		Min.	Typ.	Max.		
Sum of delay between TP4_CC and TP4_FF and delays derived from TP4_FFi, rising edge of RxD	$t_{dCCRxD01}$ CC	-	-	10	ns	
Sum of delay between TP1_CC and TP1_CC and delays derived from TP4_FFi, falling edge of RxD	$t_{dCCRxD10}$ CC	-	-	10	ns	

3.23 Flash Parameters

Program Flash program and erase operation is only allowed up the $T_j = 150^\circ\text{C}$.

Table 3-42 Flash

Parameter	Symbol	Values			Unit	Note / Test Condition
		Min.	Typ.	Max.		
Program Flash Erase Time per logical sector	t_{ERP} CC	-	-	1	s	cycle count < 1000
		-	$0.207 + 0.003 * (S \text{ [KByte]} / (f_{\text{FSI}} \text{ [MHz]}))^1$	-	s	cycle count < 1000, for sector of size S
Program Flash Erase Time per Multi-Sector Command	t_{MERP} CC	-	-	1	s	For consecutive logical sectors in a physical sector, cycle count < 1000
		-	$0.207 + 0.003 * (S \text{ [KByte]} / (f_{\text{FSI}} \text{ [MHz]}))^1$	-	s	For consecutive logical sector range of size S in a physical sector, cycle count < 1000
Program Flash program time per page in 3.3 V mode	t_{PRP3} CC	-	-	$81 + 3400 / (f_{\text{FSI}} \text{ [MHz]})$	μs	32 Byte
Program Flash program time per burst in 3.3 V mode	t_{PRPB3} CC	-	-	$410 + 12000 / (f_{\text{FSI}} \text{ [MHz]})$	μs	256 Byte
Program Flash program time for 1 MByte with burst programming in 3 V mode excluding communication	$t_{\text{PRPB3_1MB}}$ CC	-	-	2.2	s	Derived value for documentation purpose, valid for $f_{\text{FSI}} = 100\text{MHz}$
Write Page Once adder	t_{ADD} CC	-	-	$15 + 500 / (f_{\text{FSI}} \text{ [MHz]})$	μs	Adder to Program Time when using Write Page Once
Program Flash suspend to read latency	t_{SPNDP} CC	-	-	$12000 / (f_{\text{FSI}} \text{ [MHz]})$	μs	For Write Burst, Verify Erased and for multi-(logical) sector erase commands
Data Flash Erase Time per Sector ²⁾	t_{ERD} CC	-	$0.12 + 0.08 / (f_{\text{FSI}} \text{ [MHz]})^1$	-	s	cycle count < 1000
		-	$0.57 + 0.15 / (f_{\text{FSI}} \text{ [MHz]})^1$	$0.928 + 0.15 / (f_{\text{FSI}} \text{ [MHz]})$	s	cycle count < 125000

Electrical Specification Flash Parameters

Table 3-42 Flash (cont'd)

Parameter	Symbol	Values			Unit	Note / Test Condition
		Min.	Typ.	Max.		
Data Flash Erase Time per Multi-Sector Command ²⁾	t_{MERD} CC	-	$0.12 + 0.01 * (S \text{ [KByte]} / (f_{FSI} \text{ [MHz]})^1)$	-	s	For consecutive logical sector range of size S, cycle count < 1000
		-	$0.57 + 0.019 * (S \text{ [KByte]} / (f_{FSI} \text{ [MHz]})^1)$	$0.928 + 0.019 * (S \text{ [KByte]} / (f_{FSI} \text{ [MHz]})^1)$	s	For consecutive logical sector range of size S, cycle count < 125000
Data Flash erase disturb limit	N_{DFD} CC	-	-	50	cycles	
Program time data flash per page ³⁾	t_{PRD} CC	-	-	$50 + 2500 / (f_{FSI} \text{ [MHz]})^3$	μs	8 Byte
Data Flash program time per burst ³⁾	t_{PRDB} CC	-	-	$96 + 4400 / (f_{FSI} \text{ [MHz]})^3$	μs	32 Bytes
Data Flash suspend to read latency	t_{SPNDD} CC	-	-	$12000 / (f_{FSI} \text{ [MHz]})$	μs	
Wait time after margin change	$t_{FL_MarginDel}$ CC	-	-	10	μs	
Program Flash Retention Time, Sector	t_{RET} CC	20	-	-	years	Max. 1000 erase/program cycles
Data Flash Endurance per EEPROMx sector ⁴⁾	N_{E_EEP10} CC	125000	-	-	cycles	Max. data retention time 10 years
UCB Retention Time	t_{RTU} CC	20	-	-	years	Max. 100 erase/program cycles per UCB, max 400 erase/program cycles in total
Data Flash access delay	t_{DF} CC	-	-	100	ns	see PMU_FCON.WSDFLASH
Data Flash ECC Delay	t_{DFECC} CC	-	-	20	ns	see PMU_FCON.WSECDF
Program Flash access delay	t_{PF} CC	-	-	30	ns	see PMU_FCON.WSPFLASH
Program Flash ECC delay	t_{PFECC} CC	-	-	10	ns	see PMU_FCON.WSECPF

Table 3-42 Flash (cont'd)

Parameter	Symbol	Values			Unit	Note / Test Condition
		Min.	Typ.	Max.		
Number of erase operations on DF0 over lifetime	N_{ERD0} CC	-	-	750000	cycles	
Junction temperature limit for PFlash program/erase operations	$T_{JPFlash}$ SR	-	-	150	°C	

- 1) All typical values were characterised, but are not tested. Typical values are safe median values at room temperature
- 2) Under out-of-spec conditions (e.g. over-cycling) or in case of activation of WL oriented defects, the duration of erase processes may be increased by up to 50%.
- 3) Time is not dependent on program mode (5V or 3.3V).
- 4) Only valid when a robust EEPROM emulation algorithm is used. For more details see the Users Manual.

3.24 Package Outline



Figure 3-19 Package Outlines PG-LFBGA-292-6



Figure 3-20 Package Outlines PG-TQFP-144-27

Table 3-43 Exposed Pad Dimensions

Ex; valid for Feature Package L and LP (nominal EPad size)	5.7 mm ± 50 μm
Ey; valid for Feature Package L and LP (nominal EPad size)	5.7 mm ± 50 μm
Ax; valid for Feature Package L and LP (solder able EPad size)	4.9 mm ± 50 μm
Ay; valid for Feature Package L and LP (solder able EPad size)	4.9 mm ± 50 μm

Note: It is recommended to use dimensions E_x and E_y for board layout considerations. Solder wetting between E_x / E_y and A_x / A_y and lead between E_x / E_y and A_x / A_y will not cause any harm.

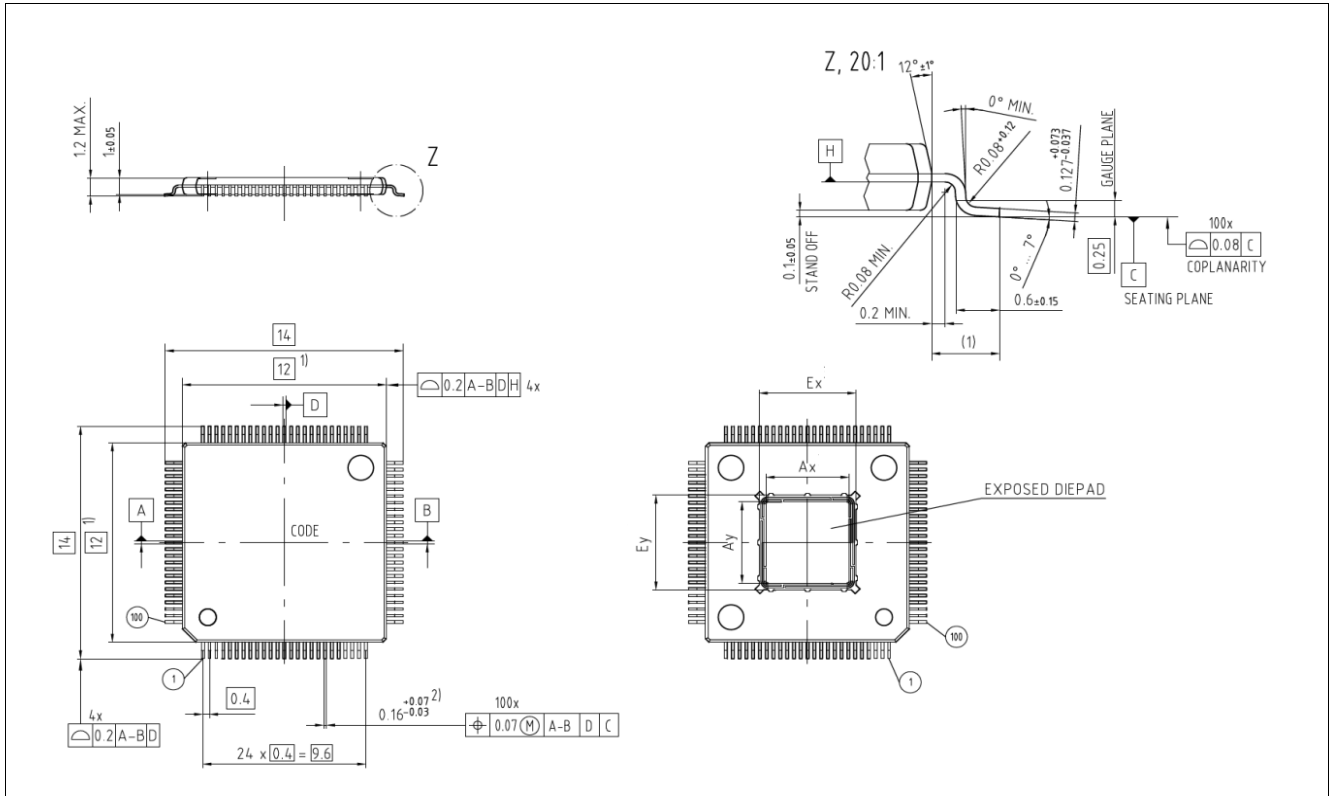

Figure 3-21 Package Outlines PG-TQFP-100-23

Table 3-44 Exposed Pad Dimensions

Ex; valid for Feature Package L, LC, LP, S, and SP (nominal EPad size)	5.7 mm ± 50 µm
Ey; valid for Feature Package L, LC, LP, S, and SP (nominal EPad size)	5.7 mm ± 50 µm
Ax; valid for Feature Package L, LC, LP, S, and SP (solder able EPad size)	4.9 mm ± 50 µm
Ay; valid for Feature Package L, LC, LP, S, and SP (solder able EPad size)	4.9 mm ± 50 µm

Note: It is recommended to use dimensions Ex and Ey for board layout considerations. Solder wetting between Ex / Ey and Ax / Ay and lead between Ex / Ey and Ax / Ay will not cause any harm.

You can find all of our packages, sorts of packing and others in our Infineon Internet Page "Products": <http://www.infineon.com/products>.

3.24.1 Package Parameters

Table 3-45 Thermal Characteristics of the Package

Device	Package	RQJCT ⁽¹⁾	RQJCB ⁽¹⁾	RQJA	Unit	Note
TC233	PG-TQFP-100-23	21.2	12.1	30.4 ⁽²⁾	K/W	with soldered exposed pad and internal pass device
		11.9	2.9	20.4 ⁽²⁾	K/W	with soldered exposed pad and DCDC EVR

Table 3-45 Thermal Characteristics of the Package

Device	Package	RQJCT ¹⁾	RQJCB ¹⁾	RQJA	Unit	Note
TC234	PG-TQFP-144-27	20.9	11.7	30.0 ²⁾	K/W	with soldered exposed pad and internal pass device
		11.7	2.8	19.8 ²⁾	K/W	with soldered exposed pad and DCDC EVR
TC237	PG-LFBGA-292-6	13.7	21.0	33.1 ²⁾	K/W	with internal pass device
		7.6	14.1	25.4 ²⁾	K/W	with DCDC EVR

- 1) The top and bottom thermal resistances between the case and the ambient (R_{TCAT} , R_{TCAB}) are to be combined with the thermal resistances between the junction and the case given above (R_{TJCT} , R_{TJCB}), in order to calculate the total thermal resistance between the junction and the ambient (R_{TJA}). The thermal resistances between the case and the ambient (R_{TCAT} , R_{TCAB}) depend on the external system (PCB, case) characteristics, and are under user responsibility.
 The junction temperature can be calculated using the following equation: $T_J = T_A + R_{TJA} * P_D$, where the R_{TJA} is the total thermal resistance between the junction and the ambient. This total junction ambient resistance R_{TJA} can be obtained from the upper four partial thermal resistances.
 Thermal resistances as measured by the 'cold plate method' (MIL SPEC-883 Method 1012.1).
- 2) Value is defined in accordance with JEDEC JESD51-3, JESD51-5, and JESD51-7.

3.25 Quality Declarations

Table 3-46 Quality Parameters

Parameter	Symbol	Values			Unit	Note / Test Condition
		Min.	Typ.	Max.		
Operation Lifetime	t_{OP}	-	-	24500	hour	
ESD susceptibility according to Human Body Model (HBM)	V_{HBM}	-	-	2000	V	Conforming to JESD22-A114-B
ESD susceptibility according to Charged Device Model (CDM)	V_{CDM}	-	-	500	V	for all other balls/pins; conforming to JESD22-C101-C
		-	-	750	V	for corner balls/pins; conforming to JESD22-C101-C
Moisture Sensitivity Level	MSL	-	-	3		Conforming to Jedec J-STD--020C for 240C

4 History

4.1 Changes from Version TC23x_DS_v1.1 to Version TC23xAC_DS_v1.0

This Data Sheet is only valid for the Feature Packages L, LC, LP, S, and SP.

Feature Packages S and SP are newly added.

- PG-LFBGA-292-6 Package Varinat Pin Configuration of TC237x
 - Remove pin U17 from the NC list
- Overload
 - Remove parameter I_{ING}
- changes in table 'Class_S' of Standard_Pads
 - add footnote ' $V_{ILx} = 0.65 * V_{DDM}$ ' to V_{IHS}
 - add footnote ' $V_{ILx} = 0.41 * V_{DDM}$ ' to V_{ILS}
- Back-up Clock
 - Add parameter f_{BACKSS}
- EVR
 - Update footnote of *EVR* to 'It is recommended to place the flying capacitor close to the pins without vias to have minimal routing resistance from pin to the capacitor terminal of less than 25mOhm. Likewise it is recommended to limit the routing resistance to input and output capacitor is to less than 25mOhm.'
- EVR/LDO
 - Update footnote of *LDO* to 'LDO operation is only possible for $T_J \leq 150^\circ\text{C}$.'
- Changes in table 'VOUTT TC23xAC' of EVR/LDO
 - Change of V_{OUTT13} from load equal to I_{DD} of max power pattern; either $T_J \leq 150^\circ\text{C}$ and pass device=on chip or $T_J \leq 170^\circ\text{C}$ and pass device=off chip to load equal to I_{DD} of max power pattern; pass device=on chip
- VADC
 - Add parameter t_{WU}
 - Add parameter R_{MDU}
 - Add parameter R_{MDD}
- VADC_33
 - Add parameter t_{WU}
 - Add parameter R_{MDU}
 - Add parameter R_{MDD}
- Power Supply
 - Change max value of $I_{EVR SB}$ from 650 μA to 150 μA
 - Change note of $I_{EVR SB}$ from 'Standby RAM is active. Power to remaining domains switched off. $T_J = 25^\circ\text{C}$ ' to 'Standby RAM is active. Power to remaining domains switched off. $T_J = 25^\circ\text{C}$; $V_{EVR SB} = 5\text{V}$ '
 - Change max value of $I_{DDPORST}$ from 70 mA to 85 mA for Note 'valid for Feature Package L, LC, and LP; $T_J = 165^\circ\text{C}$ '
 - Change max value of $I_{DDPORST}$ from 45 mA to 60 mA for Note 'valid for Feature Package L, LC, and LP; $T_J = 150^\circ\text{C}$ '

HistoryChanges from Version TC23x_DS_v1.1 to Version TC23xAC_DS_v1.0

- Change max value of $I_{DDPORST}$ from 25 mA to 40 mA for Note 'valid for Feature Package L, LC, and LP; $T_J=125^{\circ}\text{C}$ '
- Update formulas 3.2 and 3.3
- add formulas 3.4 and 3.5

www.infineon.com

Published by Infineon Technologies AG

Компания «Океан Электроники» предлагает заключение долгосрочных отношений при поставках импортных электронных компонентов на взаимовыгодных условиях!

Наши преимущества:

- Поставка оригинальных импортных электронных компонентов напрямую с производств Америки, Европы и Азии, а так же с крупнейших складов мира;
- Широкая линейка поставок активных и пассивных импортных электронных компонентов (более 30 млн. наименований);
- Поставка сложных, дефицитных, либо снятых с производства позиций;
- Оперативные сроки поставки под заказ (от 5 рабочих дней);
- Экспресс доставка в любую точку России;
- Помощь Конструкторского Отдела и консультации квалифицированных инженеров;
- Техническая поддержка проекта, помощь в подборе аналогов, поставка прототипов;
- Поставка электронных компонентов под контролем ВП;
- Система менеджмента качества сертифицирована по Международному стандарту ISO 9001;
- При необходимости вся продукция военного и аэрокосмического назначения проходит испытания и сертификацию в лаборатории (по согласованию с заказчиком);
- Поставка специализированных компонентов военного и аэрокосмического уровня качества (Xilinx, Altera, Analog Devices, Intersil, Interpoint, Microsemi, Actel, Aeroflex, Peregrine, VPT, Syfer, Eurofarad, Texas Instruments, MS Kennedy, Miteq, Cobham, E2V, MA-COM, Hittite, Mini-Circuits, General Dynamics и др.);

Компания «Океан Электроники» является официальным дистрибьютором и эксклюзивным представителем в России одного из крупнейших производителей разъемов военного и аэрокосмического назначения «JONHON», а так же официальным дистрибьютором и эксклюзивным представителем в России производителя высокотехнологичных и надежных решений для передачи СВЧ сигналов «FORSTAR».



JONHON

«JONHON» (основан в 1970 г.)

Разъемы специального, военного и аэрокосмического назначения:

(Применяются в военной, авиационной, аэрокосмической, морской, железнодорожной, горно- и нефтедобывающей отраслях промышленности)

«FORSTAR» (основан в 1998 г.)

ВЧ соединители, коаксиальные кабели, кабельные сборки и микроволновые компоненты:

(Применяются в телекоммуникациях гражданского и специального назначения, в средствах связи, РЛС, а так же военной, авиационной и аэрокосмической отраслях промышленности).



Телефон: 8 (812) 309-75-97 (многоканальный)

Факс: 8 (812) 320-03-32

Электронная почта: ocean@oceanchips.ru

Web: <http://oceanchips.ru/>

Адрес: 198099, г. Санкт-Петербург, ул. Калинина, д. 2, корп. 4, лит. А