

NHD-320240WG-ATMI-TZ#

Graphic Liquid Crystal Display Module

NHD-	Newhaven Display
320240-	320 x 240 pixels
WG-	Display Type: Graphic
A-	Model
T-	White LED Backlight
M-	STN-Blue (-)
I-	Transmissive, 6:00 Optimal View, Wide Temperature
TZ#-	Built-in Negative Voltage and Temperature Compensation
	RoHS Compliant

Newhaven Display International, Inc.

2661 Galvin Ct.

Elgin IL, 60124

Ph: 847-844-8795

Fax: 847-844-8796

www.newhavendisplay.com

nhtech@newhavendisplay.com

nhsales@newhavendisplay.com

Document Revision History

Revision	Date	Description	Changed by
0	9/25/15	Initial Release	SB

Functions and Features

- 320 x 240 pixels
- Built-in Negative Voltage
- No Controller
- NT7086 Driver
- +5.0V power supply
- RoHS Compliant
- Built-in Temperature Compensation Circuit

Mechanical Drawing

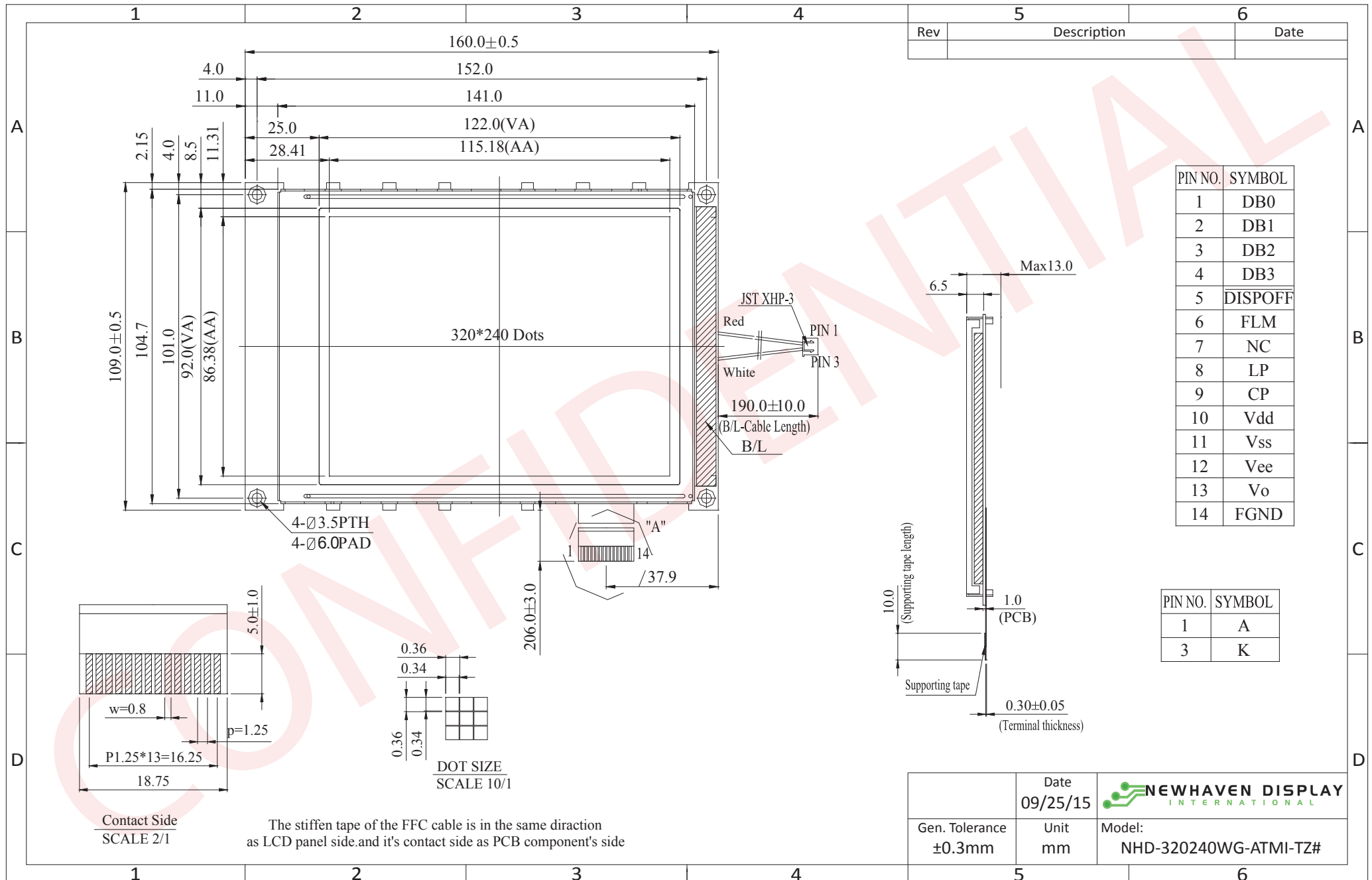

The drawing contained herein is the exclusive property of Newhaven Display International, Inc. and shall not be copied, reproduced, and/or disclosed in any format without permission.

Pin Description and Wiring Diagram

Pin No.	Symbol	External Connection	Function Description
1-4	DB0-DB3	MPU	Signal data bus
5	DISP OFF	MPU	Display On/Off
6	FLM	MPU	Scan Start-up signal
7	M	-	No Connect
8	LP	MPU	Data latch pulse
9	CP	MPU	Data shift pulse
10	VDD	Power Supply	Supply voltage for logic (+5.0V)
11	VSS	Power Supply	Ground
12	VEE	Power Supply	Negative voltage output (-25V)
13	VO	Adj. Power Supply	Supply voltage for contrast (approx. -18.6V)
14	FGND	-	No Connect
A	LED +	Power Supply	Backlight Anode (+3.5V)
K	LED -	Power Supply	Backlight Cathode (Ground)

Recommended LCD connector: 1.25mm pitch, 14-pos FFC connector **Mates with:** Molex p/n 0039532144

Backlight connector: JST p/n: XHP-3 **Mates with:** JST p/n: B 3B-XH-A

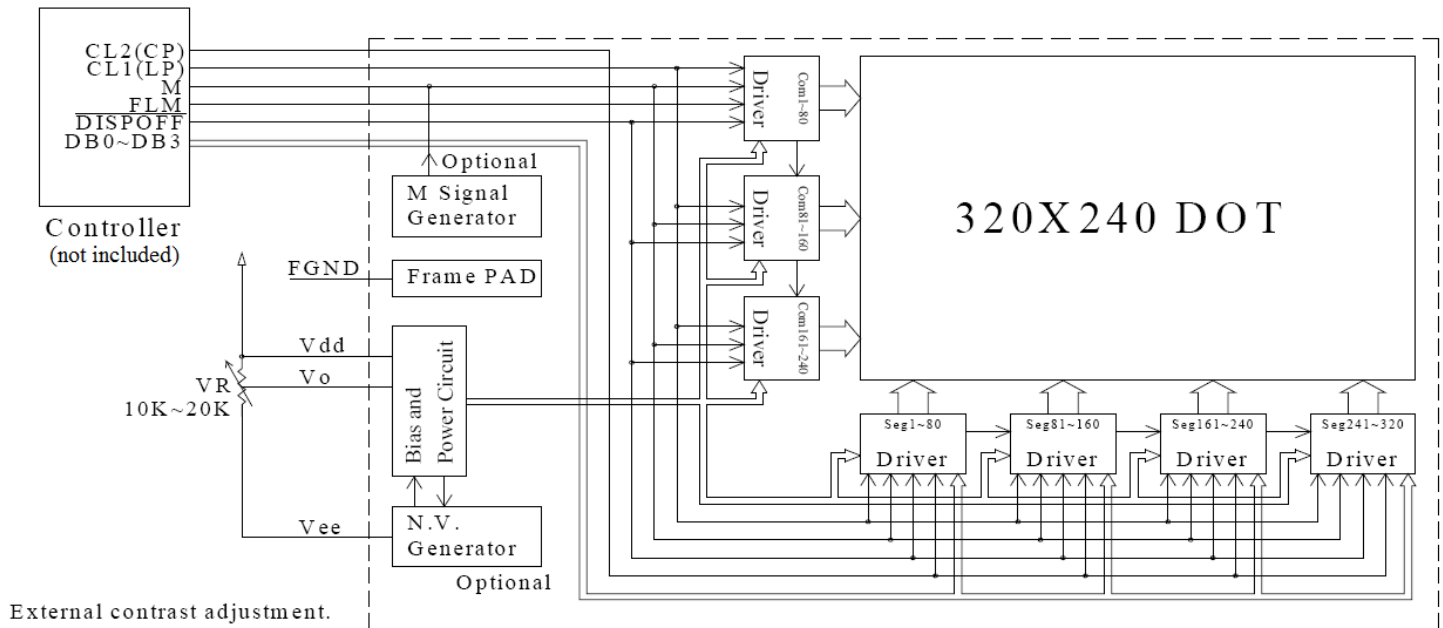

Electrical Characteristics

Item	Symbol	Condition	Min.	Typ.	Max.	Unit
Operating Temperature Range	Top	Absolute Max	-20	-	+70	°C
Storage Temperature Range	Tst	Absolute Max	-30	-	+80	°C
Supply Voltage	VDD		2.7	5.0	5.5	V
Supply Current	IDD	Ta=25°C, VDD=5.0V	60	75	80	mA
Supply for LCD (contrast)	VDD-V0	Ta=25°C	23	23.6	24.2	V
"H" Level input	VIH		0.8*VDD	-	VDD	V
"L" Level input	VIL	-	0	-	0.2*VDD	V
"H" Level output	VOH	-	VDD-0.4	-	VDD	V
"L" Level output	VOL	-	-	-	0.4	V
Backlight Supply Voltage	VLED		3.4	3.5	3.6	V
Backlight Supply Current	ILED	VLED=3.5V	-	128	160	mA

Optical Characteristics

Item	Symbol	Condition	Min.	Typ.	Max.	Unit
Viewing Angle – Top		Cr ≥ 2	-	20	-	°
Viewing Angle – Bottom			-	40	-	°
Viewing Angle – Left			-	30	-	°
Viewing Angle – Right			-	30	-	°
Contrast Ratio	Cr		-	3	-	
Response Time (rise)	Tr	-	-	200	300	ms
Response Time (fall)	Tf	-	-	250	350	ms

Driver Information

Built-in NT7086 driver.

Please download specification at http://www.newhavendisplay.com/app_notes/NT7086.pdf

Timing Characteristics

(1) Segment Driver Application

Characteristic	Symbol	Test condition	(1) VDD=5V±10%			(2) VDD=3V±10%			Unit
			Min.	Typ.	Max.	Min.	Typ.	Max.	
Clock cycle time	t _{CY}	Duty=50%	125	-	-	250	-	-	ns
Clock pulse width	t _{WCK}	-	45	-	-	95	-	-	
Clock rise/ fall time	t _R / t _F	-	-	-	-	-	-	30	
Data set-up time	t _{DS}	-	30	-	-	65	-	-	
Data hold time	t _{DH}	-	30	-	-	65	-	-	
Clock set-up time	t _{CS}	-	80	-	-	120	-	-	
Clock hold time	t _{CH}	-	80	-	-	120	-	-	
Propagation delay time	t _{PHL}	ELB output	-	-	60	-	-	125	
		ERB output	-	-	60	-	-	125	
ELB,ERB set-up time	t _{PSU}	ELB input	30	-	-	65	-	-	
		ERB input	30	-	-	65	-	-	
DISPOFFB low pulse width	t _{WDL}	-	1.2	-	-	1.2	-	-	μs
DISPOFFB clear time	t _{CD}	-	100	-	-	100	-	-	ns
M – OUT propagation delay time	t _{PD1}	C _L =15pF	-	-	1.0	-	-	1.2	μs
CL1 – OUT propagation delay time	t _{PD2}		-	-	1.0	-	-	1.2	
DISPOFFB – OUT propagation delay time	t _{PD3}		-	-	1.0	-	-	-	

(2) Common Driver Application

Characteristic	Symbol	Test condition	(1) VDD=5V±10%			(2) VDD=3V±10%			Unit
			Min.	Typ.	Max.	Min.	Typ.	Max.	
Clock cycle time	t _{CY}	Duty=50%	250	-	-	500	-	-	ns
Clock pulse width	t _{WCK}	-	45	-	-	95	-	-	
Clock rise/ fall time	t _R / t _F	-	-	-	50	-	-	50	
Data set-up time	t _{DS}	-	30	-	-	65	-	-	
Data hold time	T _{DH}	-	30	-	-	65	-	-	
DISPOFFB low pulse width	t _{WDL}	-	1.2	-	-	1.2	-	-	μs
DISPOFFB clear time	t _{CD}	-	100	-	-	100	-	-	ns
Output delay time	t _{DL}	C _L =15pF	-	-	200	-	-	250	
M – OUT propagation delay time	t _{PD1}		-	-	1.0	-	-	1.2	μs
CL1 – OUT propagation delay time	t _{PD2}		-	-	1.0	-	-	1.2	
DISPOFFB – OUT propagation delay time	t _{PD3}		-	-	1.0	-	-	1.2	

(3) Segment Driver Application Timing

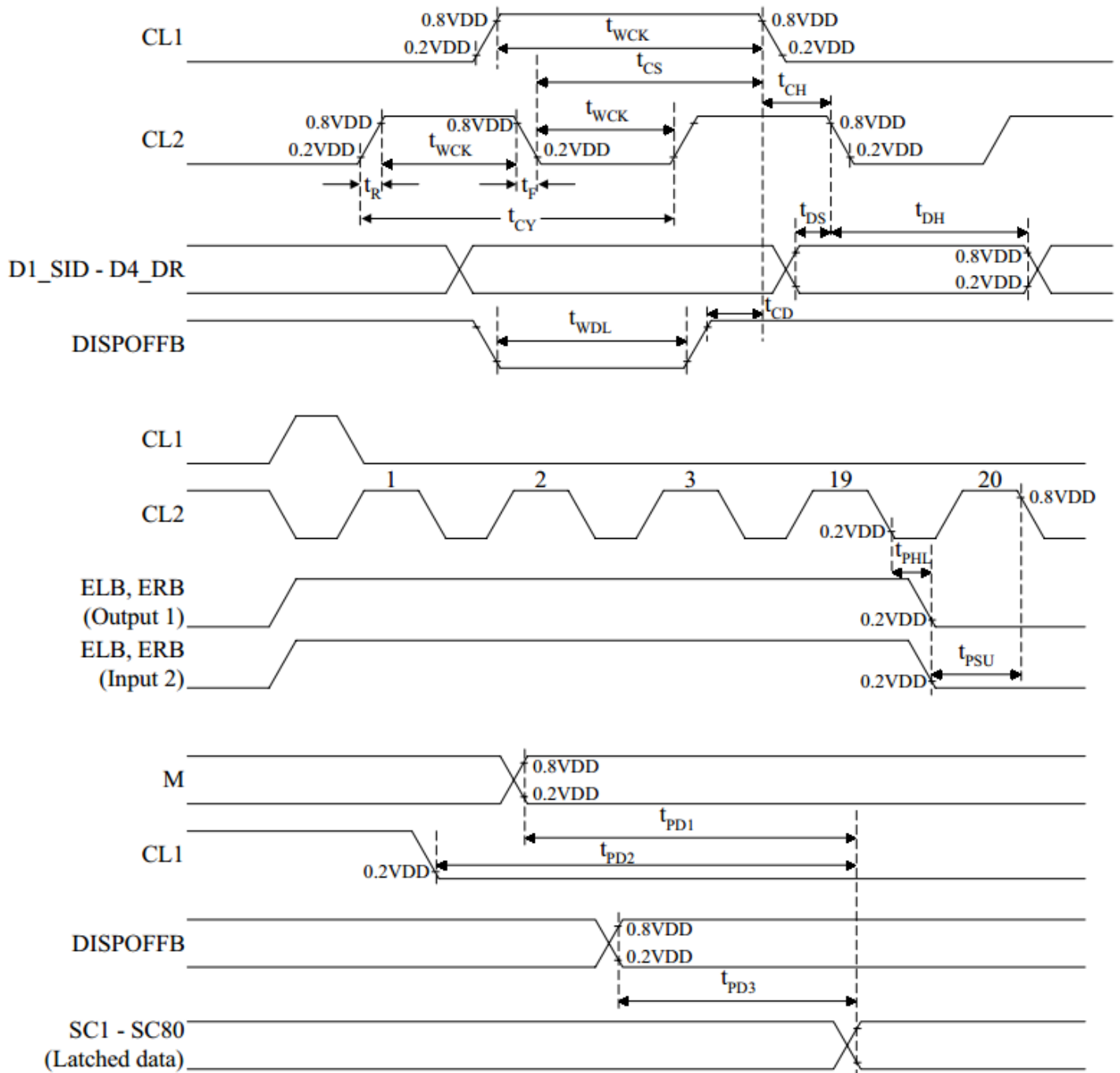

(4) Common Driver Application Timing

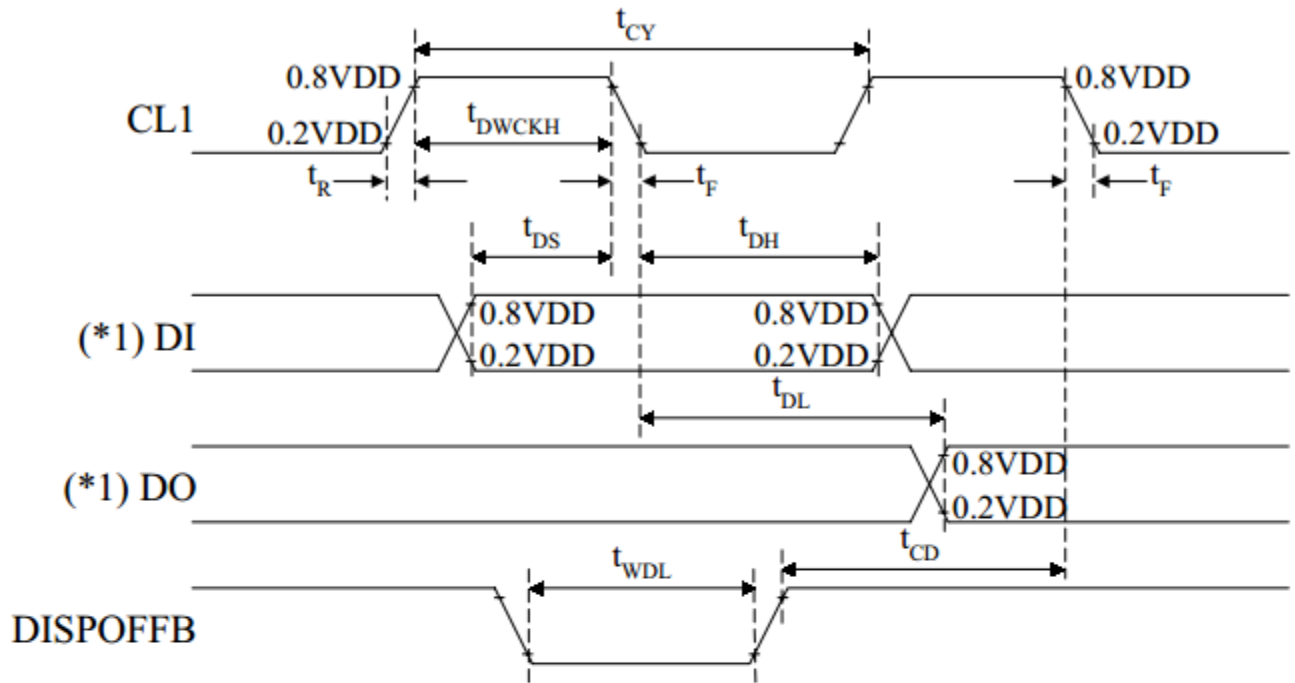

(*1) When in single-type interface mode

DI=>DDL(SHL=L), D4_DR(SHL=H)

DO=>D4_DR(SHL=L), D2_DL(SHL=H)

When in dual-type interface mode

DI=>D2_DL and D3_DM(SHL=L), D4_DR and D3_DM(SHL=H)

DO=>D4_DR(SHL=L), D2_DL(SHL=H)

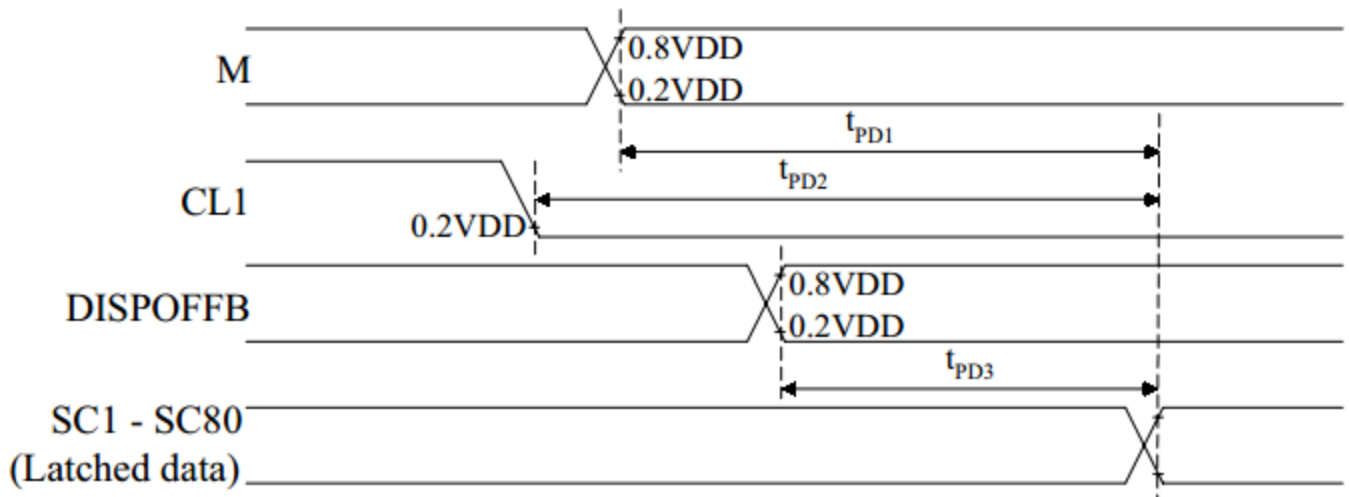

Quality Information

Test Item	Content of Test	Test Condition	Note
High Temperature storage	Endurance test applying the high storage temperature for a long time.	+80°C , 200hrs	2
Low Temperature storage	Endurance test applying the low storage temperature for a long time.	-30°C , 200hrs	1,2
High Temperature Operation	Endurance test applying the electric stress (voltage & current) and the high thermal stress for a long time.	+70°C 200hrs	
Low Temperature Operation	Endurance test applying the electric stress (voltage & current) and the low thermal stress for a long time.	-20°C , 200hrs	1
High Temperature / Humidity Operation	Endurance test applying the electric stress (voltage & current) and the high thermal with high humidity stress for a long time.	+60°C , 90% RH , 96hrs	1,2
Thermal Shock resistance	Endurance test applying the electric stress (voltage & current) during a cycle of low and high thermal stress.	-20°C,30min -> 25°C,5min -> 70°C,30min = 1 cycle 10 cycles	
Vibration test	Endurance test applying vibration to simulate transportation and use.	10-55Hz , 15mm amplitude. 60 sec in each of 3 directions X,Y,Z For 15 minutes	3
Static electricity test	Endurance test applying electric static discharge.	VS=800V, RS=1.5kΩ, CS=100pF One time	

Note 1: No condensation to be observed.

Note 2: Conducted after 4 hours of storage at 25°C, 0%RH.

Note 3: Test performed on product itself, not inside a container.

Precautions for using LCDs/LCMs

See Precautions at www.newhavendisplay.com/specs/precautions.pdf

Warranty Information and Terms & Conditions

http://www.newhavendisplay.com/index.php?main_page=terms

Компания «Океан Электроники» предлагает заключение долгосрочных отношений при поставках импортных электронных компонентов на взаимовыгодных условиях!

Наши преимущества:

- Поставка оригинальных импортных электронных компонентов напрямую с производств Америки, Европы и Азии, а так же с крупнейших складов мира;
- Широкая линейка поставок активных и пассивных импортных электронных компонентов (более 30 млн. наименований);
- Поставка сложных, дефицитных, либо снятых с производства позиций;
- Оперативные сроки поставки под заказ (от 5 рабочих дней);
- Экспресс доставка в любую точку России;
- Помощь Конструкторского Отдела и консультации квалифицированных инженеров;
- Техническая поддержка проекта, помощь в подборе аналогов, поставка прототипов;
- Поставка электронных компонентов под контролем ВП;
- Система менеджмента качества сертифицирована по Международному стандарту ISO 9001;
- При необходимости вся продукция военного и аэрокосмического назначения проходит испытания и сертификацию в лаборатории (по согласованию с заказчиком);
- Поставка специализированных компонентов военного и аэрокосмического уровня качества (Xilinx, Altera, Analog Devices, Intersil, Interpoint, Microsemi, Actel, Aeroflex, Peregrine, VPT, Syfer, Eurofarad, Texas Instruments, MS Kennedy, Miteq, Cobham, E2V, MA-COM, Hittite, Mini-Circuits, General Dynamics и др.);

Компания «Океан Электроники» является официальным дистрибьютором и эксклюзивным представителем в России одного из крупнейших производителей разъемов военного и аэрокосмического назначения «JONHON», а так же официальным дистрибьютором и эксклюзивным представителем в России производителя высокотехнологичных и надежных решений для передачи СВЧ сигналов «FORSTAR».



JONHON

«JONHON» (основан в 1970 г.)

Разъемы специального, военного и аэрокосмического назначения:

(Применяются в военной, авиационной, аэрокосмической, морской, железнодорожной, горно- и нефтедобывающей отраслях промышленности)

«FORSTAR» (основан в 1998 г.)

ВЧ соединители, коаксиальные кабели, кабельные сборки и микроволновые компоненты:

(Применяются в телекоммуникациях гражданского и специального назначения, в средствах связи, РЛС, а так же военной, авиационной и аэрокосмической отраслях промышленности).



Телефон: 8 (812) 309-75-97 (многоканальный)

Факс: 8 (812) 320-03-32

Электронная почта: ocean@oceanchips.ru

Web: <http://oceanchips.ru/>

Адрес: 198099, г. Санкт-Петербург, ул. Калинина, д. 2, корп. 4, лит. А