

MAX8934A Evaluation Kit

Evaluates: MAX8934A–MAX8934E

General Description

The MAX8934A evaluation kit (EV kit) is a fully assembled and tested circuit for evaluating the MAX8934A dual-input linear charger and Smart Power Selector™ with advanced temperature monitoring.

The EV kit charges a single-cell lithium-ion (Li+) battery from either a DC input (AC adapter) or a USB 100mA/500mA source, and provides system power from the DC input, USB input, or battery. The DC input has a resistor-adjustable current limit up to 2A, while the USB input-current limit is logic programmable to 100mA/500mA. USB suspend mode is also supported. The charge current limit is adjustable from 300mA to 1.5A. The system load has priority over the charger, so charge current is reduced as necessary to prevent input overload. Charge current is also thermally regulated. Advanced battery temperature monitoring adjusts charge current and termination voltage automatically.

The EV kit comes standard with the MAX8934A installed, but can also be used to evaluate the MAX8934B, MAX8934C, MAX8934D, and MAX8934E by replacing the MAX8934A (U1) with the MAX8934_. Request a free sample of the MAX8934_ when ordering the EV kit.

Features

- ◆ **Battery Temperature Monitor Adjusts Charge Current and Termination Voltage Automatically**
 - Potentiometer Adjustment Available
 - 0603 Thermistor Footprint Available
 - Advanced Thermistor Configuration Available (R21, R22)
 - Thermistor Enable Input (THMEN)
- ◆ **Adjustable Input-Current Limit and Fast-Charge Current Limit**
 - Fast-Charge Current Limit: 750mA and 1.5A (JU5)
 - USB Input-Current Limit: 475mA and 95mA (PEN1, PEN2)
 - DC Input-Current Limit Up to 2A (R2)
- ◆ **Status LED Indicators: \overline{DOK} , \overline{UOK} , \overline{CHG} , \overline{DONE} , \overline{FLT} , and \overline{OT}**
- ◆ **USB Suspend Logic Input**
- ◆ **3.3V Always-On LDO**
- ◆ **Fully Assembled and Tested**

Ordering Information

PART	TYPE
MAX8934AEVKIT+	EV KIT

+Denotes lead(Pb)-free and RoHS compliant.

Component List

DESIGNATION	QTY	DESCRIPTION
C1	1	10 μ F \pm 10%, 16V X5R ceramic capacitor (0805) Taiyo Yuden EMK212BJ106KG
C2	1	0.1 μ F \pm 10%, 10V X5R ceramic capacitor (0402) Taiyo Yuden LMK105BJ104KV
C3	1	0.068 μ F \pm 10%, 16V X5R ceramic capacitor (0402) Taiyo Yuden EMK105BJ683KV
C4, C5, C10	0	Not installed, ceramic capacitors (0402)

DESIGNATION	QTY	DESCRIPTION
C6	1	1 μ F \pm 10%, 6.3V X5R ceramic capacitor (0402) Taiyo Yuden JMK105BJ105KV
C7	1	4.7 μ F \pm 10%, 10V X5R ceramic capacitor (0805) Taiyo Yuden LMK212BJ475KD
C8	1	4.7 μ F \pm 10%, 6.3V X5R ceramic capacitor (0805) Taiyo Yuden JMK212BJ475KD
C9	0	Not installed, ceramic capacitor (1206)

Smart Power Selector is a trademark of Maxim Integrated Products, Inc.

For pricing, delivery, and ordering information, please contact Maxim Direct at 1-888-629-4642, or visit Maxim's website at www.maximintegrated.com.

MAX8934A Evaluation Kit

Evaluates: MAX8934A-MAX8934E

Component List (continued)

DESIGNATION	QTY	DESCRIPTION
C11	1	10 μ F \pm 10%, 6.3V X5R ceramic capacitor (0805) Taiyo Yuden JMK212BJ106KD
D1-D6	6	Red LEDs (0603) Panasonic LNJ208R8ARA or Green LEDs Avago HSMG-C190
J1, J2	2	USB type-AB mini jacks, right angle Molex 56579-0576
JU1, JU2, JU3, JU6, JU8	5	3-pin headers, 0.1in centers Sullins PEC36SAAN Digi-Key S1012E-36-ND
JU4, JU5, JU7, JU9-JU17	12	2-pin headers, 0.1in centers Sullins PEC36SAAN Digi-Key S1012E-36-ND
R1, R9-R13	6	4.7k Ω \pm 5% resistors (0402), lead free
R2	1	1.5k Ω \pm 1% resistor (0402), lead free
R3, R4	2	4k Ω \pm 1% resistors (0402), lead free

DESIGNATION	QTY	DESCRIPTION
R5, R21	0	Not installed, resistors (0402)
R6	0	Not installed, NTC thermistor (0603) Vishay NTHS0603N01N1003FF Murata NCP15WF104F03
R7, R8	2	100k Ω \pm 1% resistors (0402), lead free
R14-R19	6	1M Ω \pm 5% resistors (0402), lead free
R20	1	500k Ω , 25-turn potentiometer Bourns 3296Y-1-504 LF
R22	1	0 Ω \pm 1% resistor (0402), lead free
U1	1	Dual-input linear battery charger (28 TQFN-EP*) Maxim MAX8934AETI+
—	14	Shunts Sullins STC02SYAN, Mouser 151-8000, or Digi-Key S9000-ND
—	1	PCB: MAX8934A EVALUATION KIT+

*EP = Exposed pad.

Component Suppliers

SUPPLIER	PHONE	WEBSITE
Avago Technologies	877-673-9442	www.avagotech.com
Bourns, Inc.	408-496-0706	www.bourns.com
Digi-Key Corp.	800-344-4539	www.digikey.com
Molex	800-768-6539	www.molex.com
Mouser Electronics	800-346-6873	www.mouser.com
Murata Electronics North America, Inc.	770-436-1300	www.murata-northamerica.com
Panasonic Corp.	800-344-2112	www.panasonic.com
Sullins Electronics Corp.	760-744-0125	www.sullinselectronics.com
Taiyo Yuden	800-348-2496	www.t-yuden.com
TDK Corp.	847-803-6100	www.component.tdk.com
Vishay	402-563-6866	www.vishay.com

Note: Indicate that you are using the MAX8934_ when contacting these component suppliers.

MAX8934A Evaluation Kit

Evaluates: MAX8934A–MAX8934E

Quick Start

Recommended Equipment

- Adjustable DC power supply capable of at least 3A at 7V
- Battery or simulated battery
 - 1-cell Li+ or Li-Poly battery (Figure 1A)
 - Simulated battery; preloaded power supply (Figure 1B)
- Two digital multimeters (DMMs)
- Up to 3A adjustable load
- Two 3A ammeters

Procedure

The MAX8934A EV kit is fully assembled and tested. Follow the steps below to verify board operation. Use twisted wires of appropriate gauge (20AWG) that are as short as possible to connect the battery and power sources.

- Ensure that the EV kit has the jumper settings shown in Figure 2 and Table 1.
- Preset the adjustable load to 0A.
- Preset the DC power supply to 5V. Turn off the power supply. **Caution: Do not turn on the power supply until all connections are completed.**
- Connect the EV kit to the power supply, battery, or preloaded power supply, and meters, as shown in Figure 2. Set the ammeters to their largest current range (lowest series impedance).
- Turn on the power supply.
- Verify that the voltage at SYS is approximately 5V.
- If $3V \leq V_{BAT} \leq 4.1V$, verify that the current from BATT+ into the battery is approximately 0.75A.
- Increase the load current on SYS to 1A.
- Verify that the charge current into the battery remains near 0.75A.

- Increase the load current on SYS to 1.5A.
- Verify that the charge current into the battery is approximately 0.5A.
- Increase the load current on SYS to 2.5A.
- Verify that the current out of the battery is approximately 0.5A.

Detailed Description of Hardware

Adjusting the EV Kit for In-Circuit Evaluation

Follow the steps below to ensure that the EV kit is configured for operation in a specific application circuit:

- Verify that the EV kit DC input-current limit setting is less than the AC adapter source current limit.
- If necessary, replace R2 in the EV kit such that the DC input current is less than or equal to the AC adapter output-current capability.
- Verify that the USB source can supply 100mA or 500mA.
- Ensure that the charge-current setting of the EV kit does not exceed the battery rating, or replace resistor R3 and remove the shunt from JU5 as required. See the *Setting the Input-Current Limit (DC Input Path)*, *Setting the Input-Current Limit (USB Input Path)*, and *Setting the Fast-Charge Current* sections for more details.

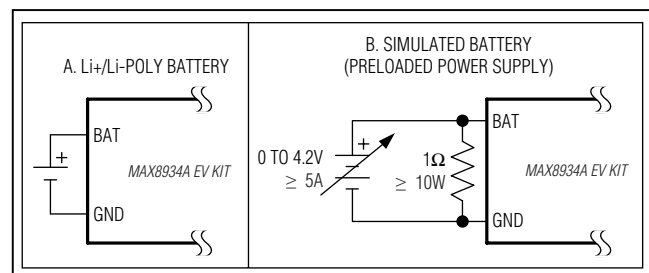

Figure 1. Battery Options for Evaluating the MAX8934A EV Kit

MAX8934A Evaluation Kit

Evaluates: MAX8934A-MAX8934E

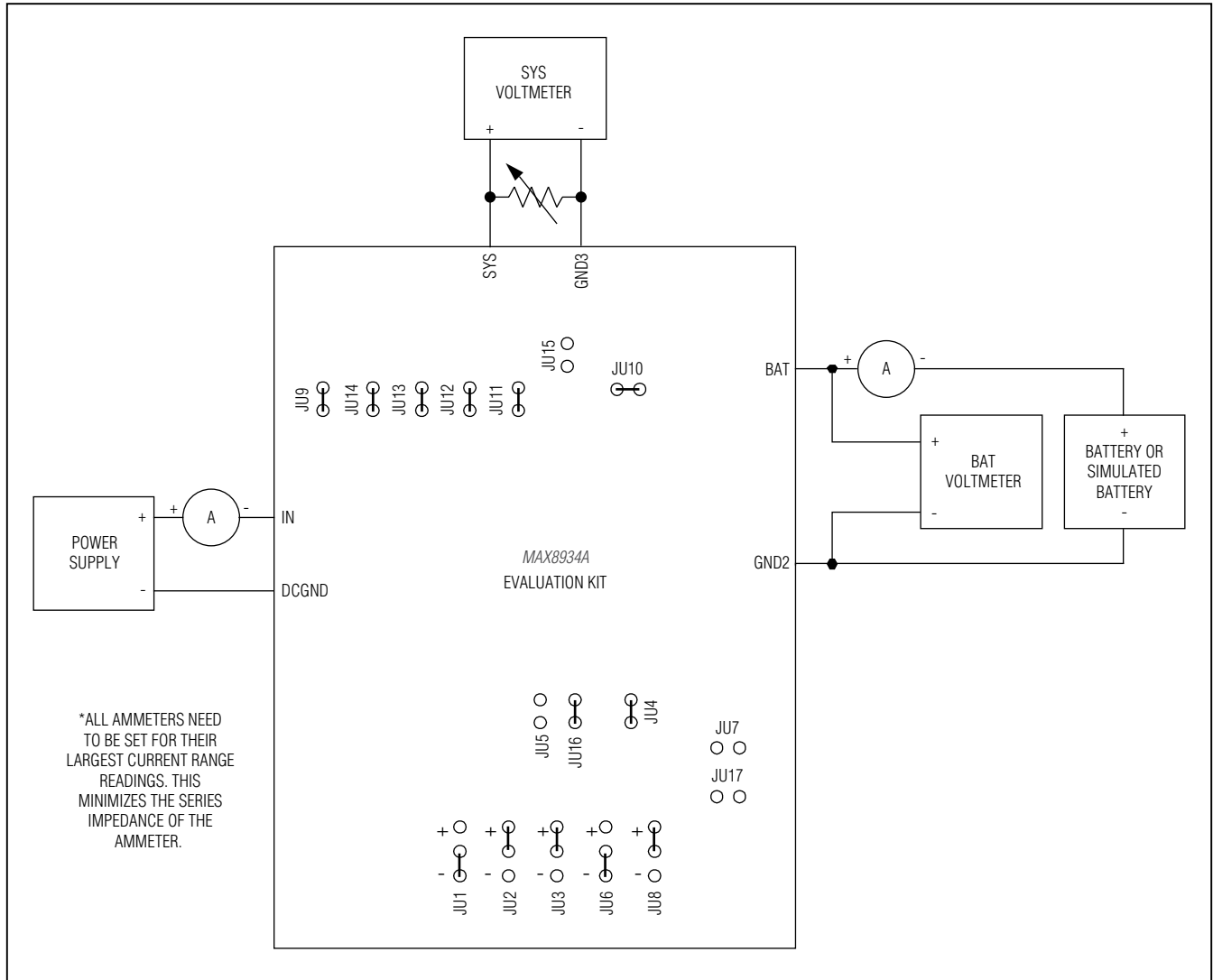

Figure 2. Connection Diagram and Default Jumper Connections

MAX8934A Evaluation Kit

Evaluates: MAX8934A–MAX8934E

Table 1. Jumper Functions

JUMPER	NODE OR FUNCTION	POSITION	FUNCTION
JU1	$\overline{\text{CEN}}$	Positive (+) to $\overline{\text{CEN}}$	Charger disabled
		Negative (-) to $\overline{\text{CEN}}^*$	Charger enabled
JU2	PEN1	Positive (+) to PEN1*	See Tables 2 and 3
JU3	PEN2	Positive (+) to PEN2*	See Tables 2 and 3
JU4	VLOGIC	Open	VLOGIC must be powered externally and cannot exceed 5.5V
		Shunt*	VLOGIC = VLDO
JU5	ISET (fast-charge current adjustment)	Open*	Fast-charge current = 750mA, R3 is connected from ISET to GND and R4 is not connected
		Shunt	Fast-charge current = 1.5A, R3 and R4 are in parallel from ISET to GND
JU6	USUS	Positive (+) to USUS	USB suspend; an external supply is required for VLOGIC
		Negative (-) to USUS*	Not in USB suspend
JU7	THM forced “hot”	Open*	THM not connected to GND
		Shunt	Connects THM to GND; forces a THM “hot” state
JU8	THMEN	Positive (+) to THMEN*	Connects THMEN to the VLOGIC rail; enables the thermistor circuit in discharge mode and enables the internal THMSW switch, pulling up R7 to THMSW
		Negative (-) to THMEN	Connects THMEN to GND; disables the internal THMSW switch in discharge mode and disables the thermistor monitoring circuit
JU9	$\overline{\text{DONE}}$ LED indicator	Open	Disconnects indicator LED D1 from $\overline{\text{DONE}}$
		Shunt*	Connects indicator LED D1 to $\overline{\text{DONE}}$
JU10	$\overline{\text{CHG}}$ LED indicator	Open	Disconnects indicator LED D2 from $\overline{\text{CHG}}$
		Shunt*	Connects indicator LED D2 to $\overline{\text{CHG}}$
JU11	$\overline{\text{OT}}$ LED indicator	Open	Disconnects indicator LED D3 from $\overline{\text{OT}}$
		Shunt*	Connects indicator LED D3 to $\overline{\text{OT}}$
JU12	$\overline{\text{DOK}}$ LED indicator	Open	Disconnects indicator LED D4 from $\overline{\text{DOK}}$
		Shunt*	Connects indicator LED D4 to $\overline{\text{DOK}}$
JU13	$\overline{\text{UOK}}$ LED indicator	Open	Disconnects indicator LED D5 from $\overline{\text{UOK}}$
		Shunt*	Connects indicator LED D5 to $\overline{\text{UOK}}$
JU14	$\overline{\text{FLT}}$ LED indicator	Open	Disconnects indicator LED D6 from $\overline{\text{FLT}}$
		Shunt*	Connects indicator LED D6 to $\overline{\text{FLT}}$
JU15	$\overline{\text{OT}}$ pullup resistor	Open*	Disconnects the $\overline{\text{OT}}$ pullup resistor (R16) from VLDO
		Shunt	Connects the $\overline{\text{OT}}$ pullup resistor (R16) to VLDO
JU16	THM to GND fixed resistor	Open	Disconnects R8 from THM
		Shunt*	Connects a 500k Ω resistor (R8) from THM to GND; R8 = R7 and sets $V_{\text{THM}} = 1/2 \times V_{\text{THMSW}}$; ensures that JU7 and JU17 are not shunted
JU17	THM to GND potentiometer	Open*	Disconnects the 500k Ω potentiometer (R20) from THM; ensures that JU7 and JU16 are not shunted
		Shunt	Connects a 500k Ω potentiometer (R20) from THM to GND; this allows evaluation of battery temperature monitoring thresholds; ensures that JU7 and JU16 are not shunted

*Default position.

MAX8934A Evaluation Kit

Evaluates: MAX8934A–MAX8934E

Charger Enable Input ($\overline{\text{CEN}}$)

Jumper JU1 controls the enable signal for the battery charger. Install JU1 between the negative terminal (-) and $\overline{\text{CEN}}$ to enable the charger. Install JU1 between the positive terminal (+) and $\overline{\text{CEN}}$ to disable the charger. Note that if no battery is connected and the charger is disabled, V_{SYS} , V_{BATT} , and V_{LDO} decay to 0V. If a battery is connected and the charger is disabled, V_{SYS} tracks V_{BATT} , and $V_{\text{LDO}} = 3.3\text{V}$. If $V_{\text{SYS}} < 3.3\text{V}$, then V_{LDO} tracks V_{SYS} .

Setting the Input-Current Limit (DC Input Path)

The DC charging path can be programmed either as an adapter input or a USB input. Install jumper JU2 between the positive terminal (+) and PEN1 to program the DC input as an adapter input. Install JU2 between the negative terminal (-) and PEN1 to program the DC input as a USB input.

Jumper JU3 (PEN2) sets the input-current limit when the DC input is configured as a USB input. Install JU3

between the positive terminal (+) and PEN2 to set the input-current limit to 500mA (max). Install JU3 between the negative terminal (-) and PEN2 to set the input-current limit to 100mA (max). Jumper JU6 programs the state of the USUS input.

Resistor R2 sets the maximum input current when the DC input is configured as an adapter input. The EV kit default value of R2, or RPSET (1.5k Ω), programs the input-current limit to 2A. **The minimum value of R2 should be 2k Ω when evaluating the MAX8934D.**

Setting the Input-Current Limit (USB Input Path)

The USB charging path can be programmed only as a USB input. Jumper JU3 (PEN2) sets the input-current limit for the USB input. Install JU3 between the positive terminal (+) and PEN2 to set the USB input-current limit to 500mA (max), or between the negative terminal (-) and PEN2 to set the USB input-current limit to 100mA (max). Jumper JU6 programs the state of the USUS input.

**Table 2. Charger Control Signal Truth Table (MAX8934A/B/C/E)
(THM Cold Threshold (T2) > THM Hot Threshold (T3))**

POWER SOURCE	$\overline{\text{DOK}}$	$\overline{\text{UOK}}$	PEN1 (JU2)	PEN2 (JU3)	USUS (JU6)	DC INPUT-CURRENT LIMIT	USB INPUT-CURRENT LIMIT	MAXIMUM CHARGE CURRENT**	
AC adapter at DC input	L	X	H*	X	X	3000V/RPSET	USB input off; DC input has priority	3000V/RISSET	
USB power at DC input	L	X	L	H*	L*	475mA		475mA	
	L	X	L	L	L	95mA		95mA	
USB power at DC input	L	X	L	X	H	USB suspend		0	
	USB power at USB input; DC unconnected	H	L	X	H	L	No DC input	475mA	3000V/RISSET
		H	L	X	L	L		95mA	
DC and USB unconnected	H	L	X	X	H	USB suspend		0	
	H	H	X	X	X	No USB input		0	

H = A shunt from the positive pin to the center pin of the respective jumper (e.g., H on PEN1 is a jumper from positive to the center pin of PEN1).

L = A shunt from the negative pin to the center pin of the respective jumper.

X = Don't care.

*Initial position on the EV kit.

**Charge current cannot exceed the input-current limit. Charge current may be less than the maximum charge current if the total SYS and BATT load exceeds the input-current limit.

MAX8934A Evaluation Kit

Evaluates: MAX8934A–MAX8934E

**Table 3. Charger Control Signal Truth Table (MAX8934D)
(THM Cold Threshold (T2) > V_{THM} > THM Hot Threshold (T3))**

FEATURE		DC INPUT			USB INPUT		NOTES	
Absolute maximum rating		16V			9V		—	
Input-current limit		Set by RPSET, PEN1, PEN2, and USUS; 2A (max)			Set by RPSET, PEN1, PEN2, and USUS; 1.5A (max)		PSET sets the same input-current limit for DC and USB paths	
POWER SOURCE	$\overline{\text{DOK}}$	$\overline{\text{UOK}}$	PEN1 (JU2)	PEN2 (JU3)	USUS (JU6)	DC INPUT-CURRENT LIMIT	USB INPUT-CURRENT LIMIT	MAXIMUM CHARGE CURRENT
AC adapter at DC	L	X	H*	X	X	3000V/RPSET	USB input off; DC input has priority	3000V/RISET
USB power at DC	L	X	H	X	X	3000V/RPSET		3000V/RISET
	L	X	L	H*	L*	475mA		475mA
	L	X	L	L	L	95mA		95mA
	L	X	L	X	H	USB suspend		0
USB power at USB; DC open	H	L	H	H	L	No DC input	3000V/RPSET	3000V/RISET
	H	L	H	L	L		600V/RPSET	3000V/RISET
	H	L	L	H	L		475mA	475mA
	H	L	L	L	L		95mA	95mA
	H	L	X	X	H		USB suspend	0
DC and USB open	H	H	X	X	X	No USB input		0

H = A shunt from the positive pin to the center pin of the respective jumper.

L = A shunt from the negative pin to the center pin of the respective jumper.

X = Don't care.

*Initial position on the EV kit.

**Charge current cannot exceed the input-current limit. Charge current may be less than the maximum charge current if the total SYS and BATT load exceeds the input-current limit.

Setting the Fast-Charge Current

Resistors R3 and R4 set the fast-charge current limit for the MAX8934A. Installing jumper JU5 connects both resistors in parallel, allowing a fast-charge current of up to 1.5A (when the DC input is configured for > 1.5A input-current limit). Removing JU5 allows a fast-charge current of 750mA. Other fast-charge currents can be set by changing the R3 and R4 resistances. Use the following equation:

$$I_{CHGMAX} = 3000V/R3 \text{ (JU5 not installed)}$$

Using the Thermistor Monitor

The MAX8934A provides a thermistor monitor circuit that automatically adjusts either the fast-charge current or the charge termination voltage, depending on the voltage at the THM input. Tables 2 and 3 are true when THM cold threshold (T2) > V_{THM} > THM hot threshold (T3). If V_{THM} is outside this range, refer to the MAX8934A–MAX8934E IC data sheet for additional details.

A 100kΩ pullup resistor (R7) to THMSW provides the bias to a thermistor (allowing ambient temperature to control the charger behavior), a fixed 100kΩ pulldown resistor (JU16, for easiest evaluation of other charger functionality), or a potentiometer (JU17, for adjusting THM voltage manually).

The THMEN input determines whether the THMSW switch is enabled, providing bias to 100kΩ pullup resistor R7. If a valid input source is present, the state of the THMEN pin is ignored, and the 100kΩ pullup resistor is always biased. If no valid input source is connected, and only a battery is present, then jumper JU8 controls the state of the thermistor bias. Install JU8 between the positive terminal (+) and THMEN to enable the thermistor bias. Install JU8 between the negative terminal (-) and THMEN to disable the thermistor bias when only a battery is present.

MAX8934A Evaluation Kit

Evaluates: MAX8934A–MAX8934E

Jumper JU7 allows intentional introduction of a temperature fault condition. Install JU7 to force a THM “hot” state, where the charger immediately stops charging the battery. When the battery is being discharged, this is a simple way of evaluating the \overline{OT} functionality.

When using alternate resistance and/or beta thermistors other than the two shown in the component list, then the circuit of Figure 3 might result in temperature trip thresholds different from the nominal values. In this case, R21 and R22 of Figure 3 allow for compensating the thermistor in order to shift the temperature trip thresholds back to the nominal value. In general, smaller values of R21 shift all the temperature trip thresholds down. However, the lower-temperature thresholds are affected more than the higher-temperature thresholds. Furthermore, larger values of R22 shift all the temperature trip thresholds up. However, the higher-temperature thresholds are affected more than the lower-temperature thresholds. For more details, refer to the MAX8934A–MAX8934E IC data sheet.

The general relation of thermistor resistance to temperature is defined by the following equation:

$$R_{THM} = R_{25} \times e^{\left(\beta \times \left(\frac{1}{T + 273^{\circ}C} - \frac{1}{298^{\circ}C} \right) \right)}$$

where:

R_{THM} = Resistance in Ω of the thermistor at temperature T in Celsius.

R_{25} = Resistance in Ω of the thermistor at +25°C.

β = Material constant of the thermistor, which typically ranges from 3000K to 5000K.

T = Temperature of the thermistor in °C.

Pullup Supply for Logic Inputs and Indicators/Fault Flags

The EV kit provides two options for biasing the logic inputs and the open-drain indicators. Either the LDO output or an external logic supply can be used to provide this bias. Install jumper JU4 to use VLDO as the bias source; otherwise, connect an external supply (2.5V to 5.5V) to V_{LOGIC} to serve as the bias source.

When evaluating the USB suspend behavior with no battery connected, it is required that an external V_{LOGIC} supply be used.

Open-Drain Indicators

The \overline{DONE} , \overline{CHG} , \overline{OT} , \overline{DOK} , \overline{UOK} , and \overline{FLT} indicators all utilize the V_{LOGIC} bias supply for their respective pullup voltages. Jumpers JU9–JU14 connect the LED indicators to each of the open-drain flags. JU15 (\overline{OT} only) connects a pullup resistor. Table 1 summarizes the functions of each jumper.

Charge Timers

A fault timer prevents the battery from charging indefinitely. The prequalification and fast-charge timers are controlled by the capacitance at CT (C3) (THM cold threshold (T2) < V_{THM} < THM hot threshold (T3)).

$$\text{PREQUAL : } t_{PQ} = 30\text{min} \times \frac{C3}{0.068\mu\text{F}}$$

$$\text{FAST CHARGE : } t_{FC} = 300\text{min} \times \frac{C3}{0.068\mu\text{F}}$$

TOP-OFF:

$$t_{TO} = 15\text{s (60min for the MAX8934B and MAX8934D)}$$

EV Kit Temperature Range

The PCB and components of the EV kit allow operation with ambient temperatures from -25°C to +85°C. Remove LEDs D1–D6, or open jumpers JU9–JU14, to increase the ambient temperature operating range from -30°C to +85°C.

Evaluating the MAX8934B, MAX8934C, MAX8934D, and MAX8934E

The EV kit comes with the MAX8934A installed, but can also be used to evaluate the MAX8934B, MAX8934C, MAX8934D, and MAX8934E. To evaluate these ICs, carefully remove the MAX8934A (U1) from the EV kit and replace with the MAX8934_. No other component change is required except when using the MAX8934D. The MAX8934D requires that R2 be removed and replaced with a 2k Ω (min) resistor. Request a free sample of the MAX8934_ when ordering the EV kit.

MAX8934A Evaluation Kit

Evaluates: MAX8934A-MAX8934E

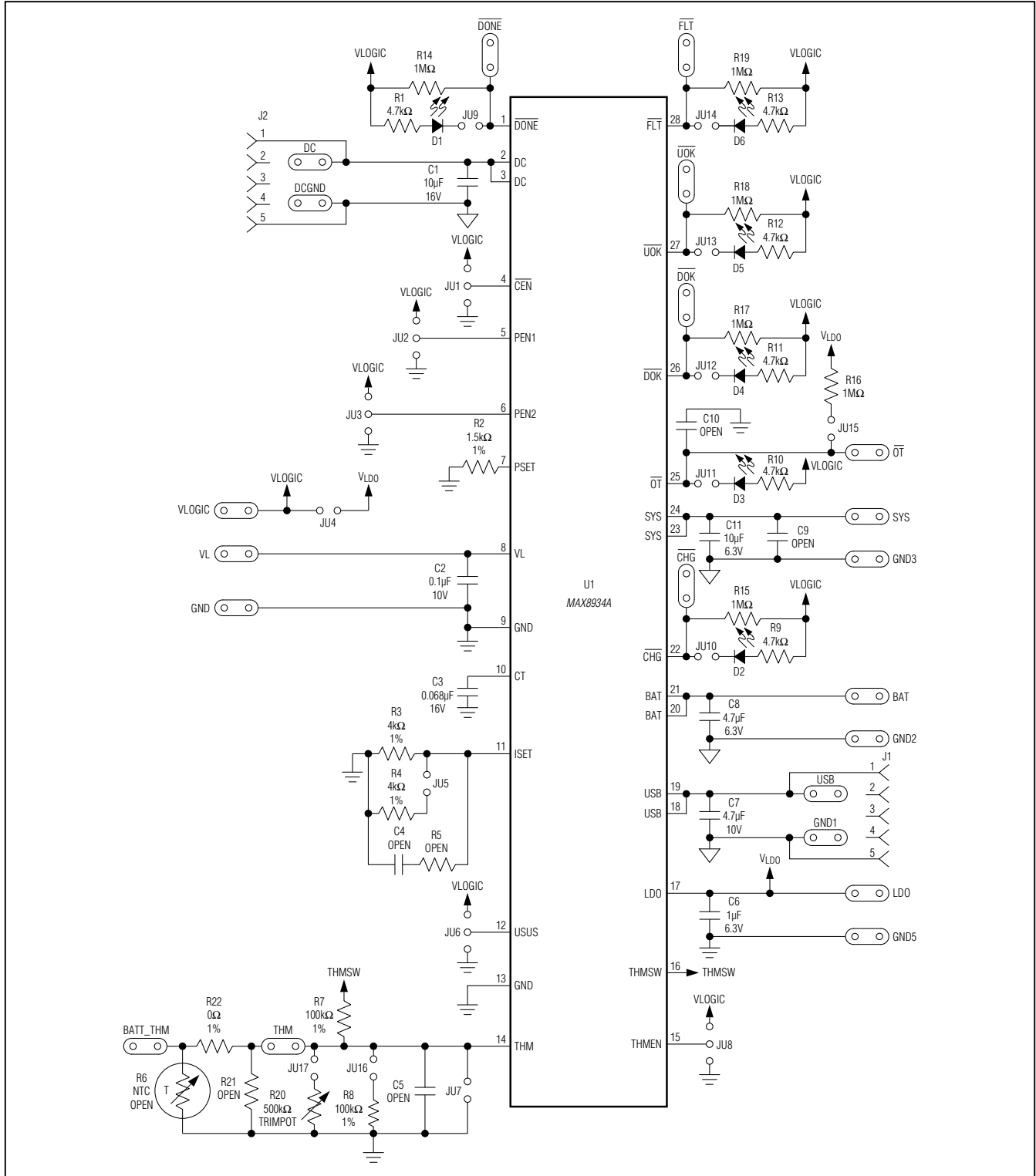

Figure 3. MAX8934A EV Kit Schematic

MAX8934A Evaluation Kit

Evaluates: MAX8934A-MAX8934E

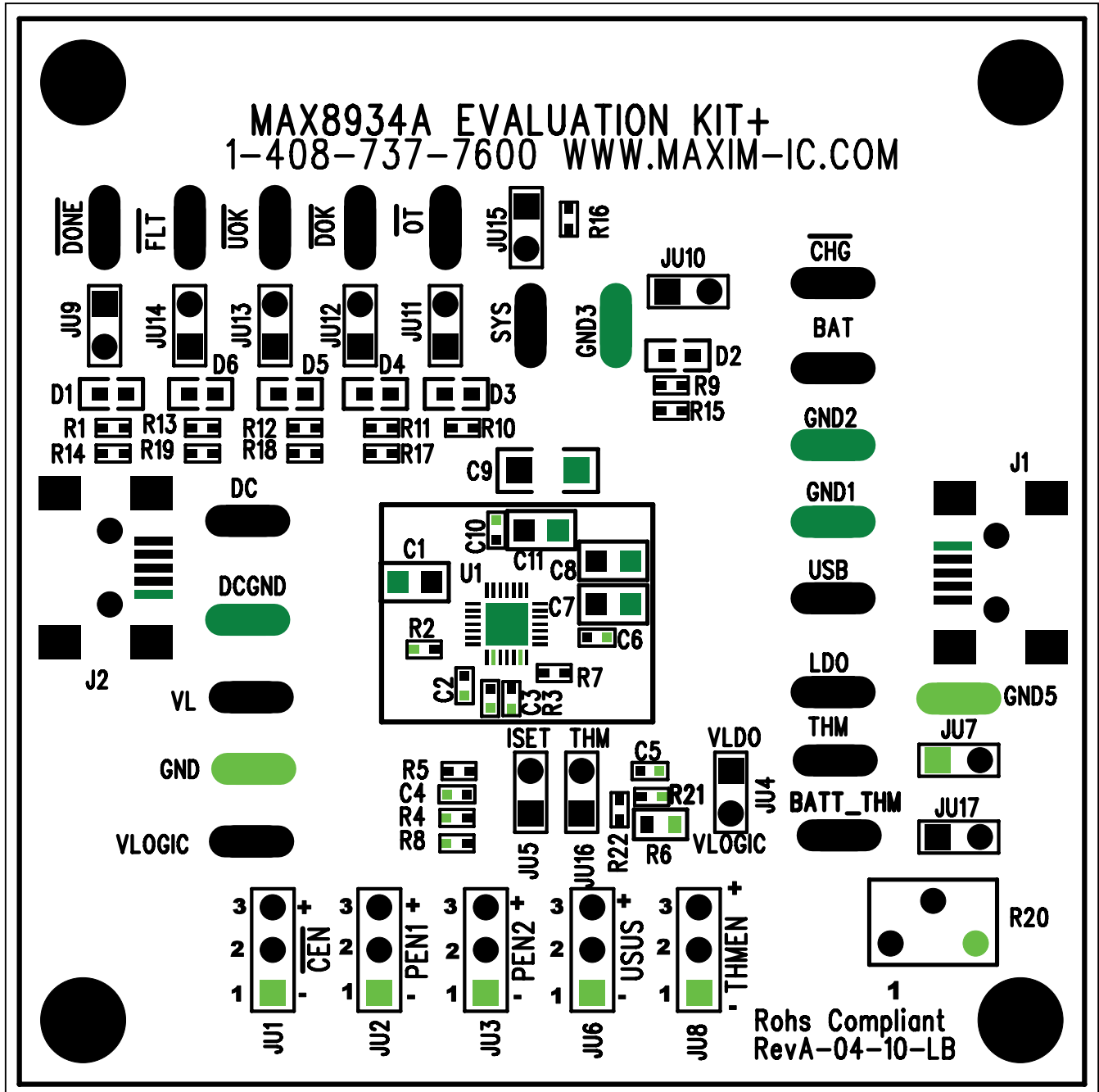

Figure 4. MAX8934A EV Kit Component Placement Guide—Top Layer

MAX8934A Evaluation Kit

Evaluates: MAX8934A-MAX8934E

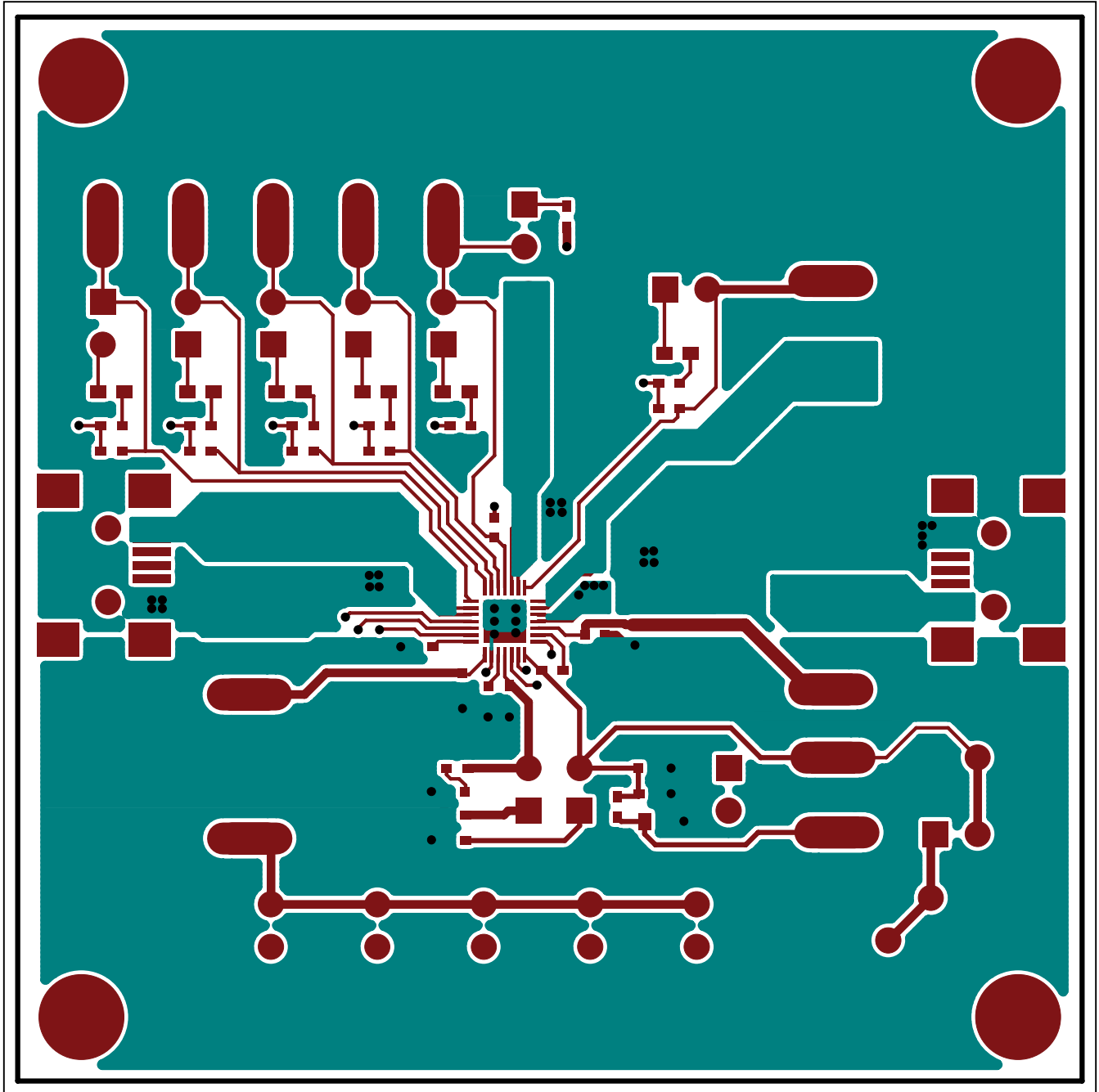

Figure 5. MAX8934A EV Kit PCB Layout—Top Layer

MAX8934A Evaluation Kit

Evaluates: MAX8934A-MAX8934E

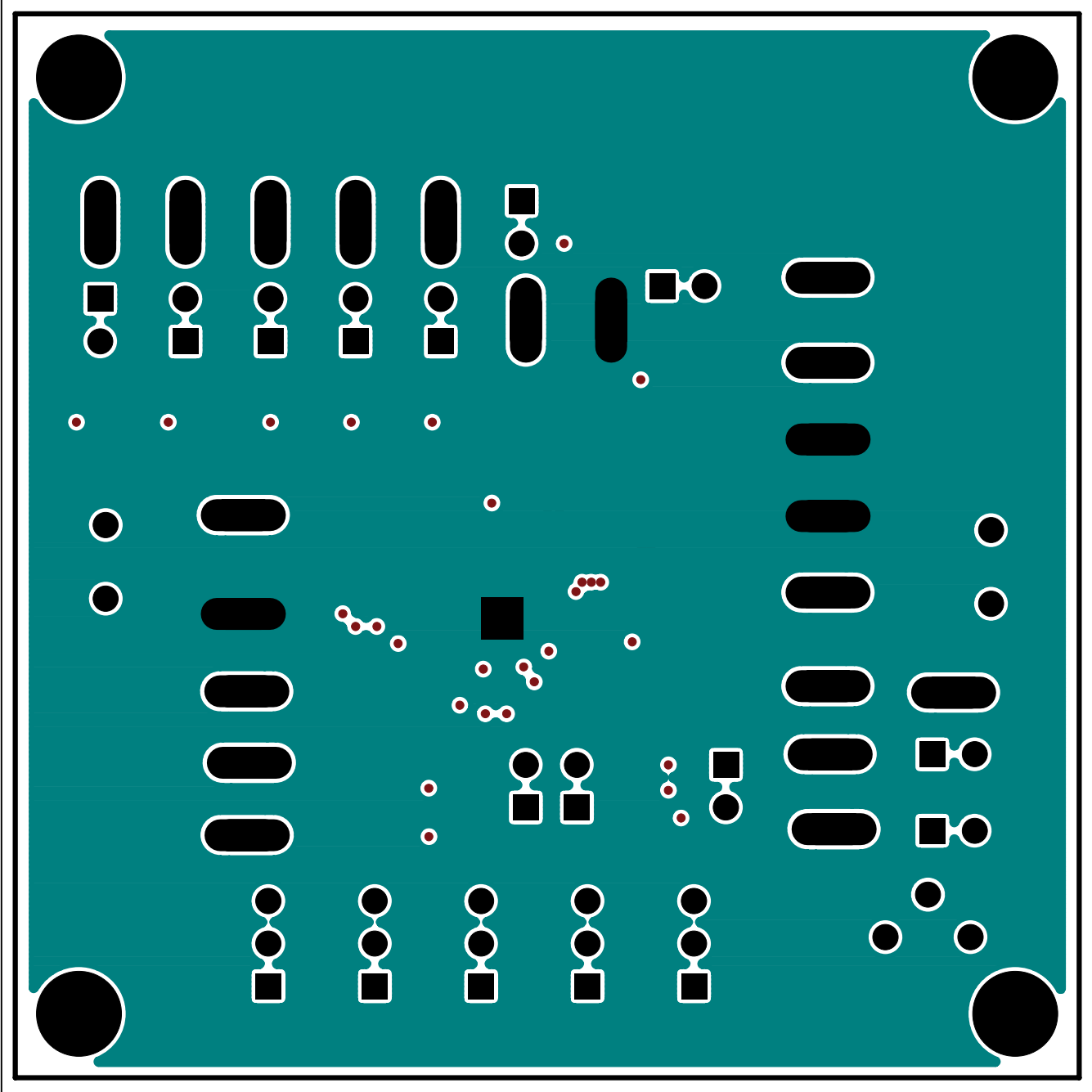

Figure 6. MAX8934A EV Kit PCB Layout—Inner Layer 2

MAX8934A Evaluation Kit

Evaluates: MAX8934A-MAX8934E

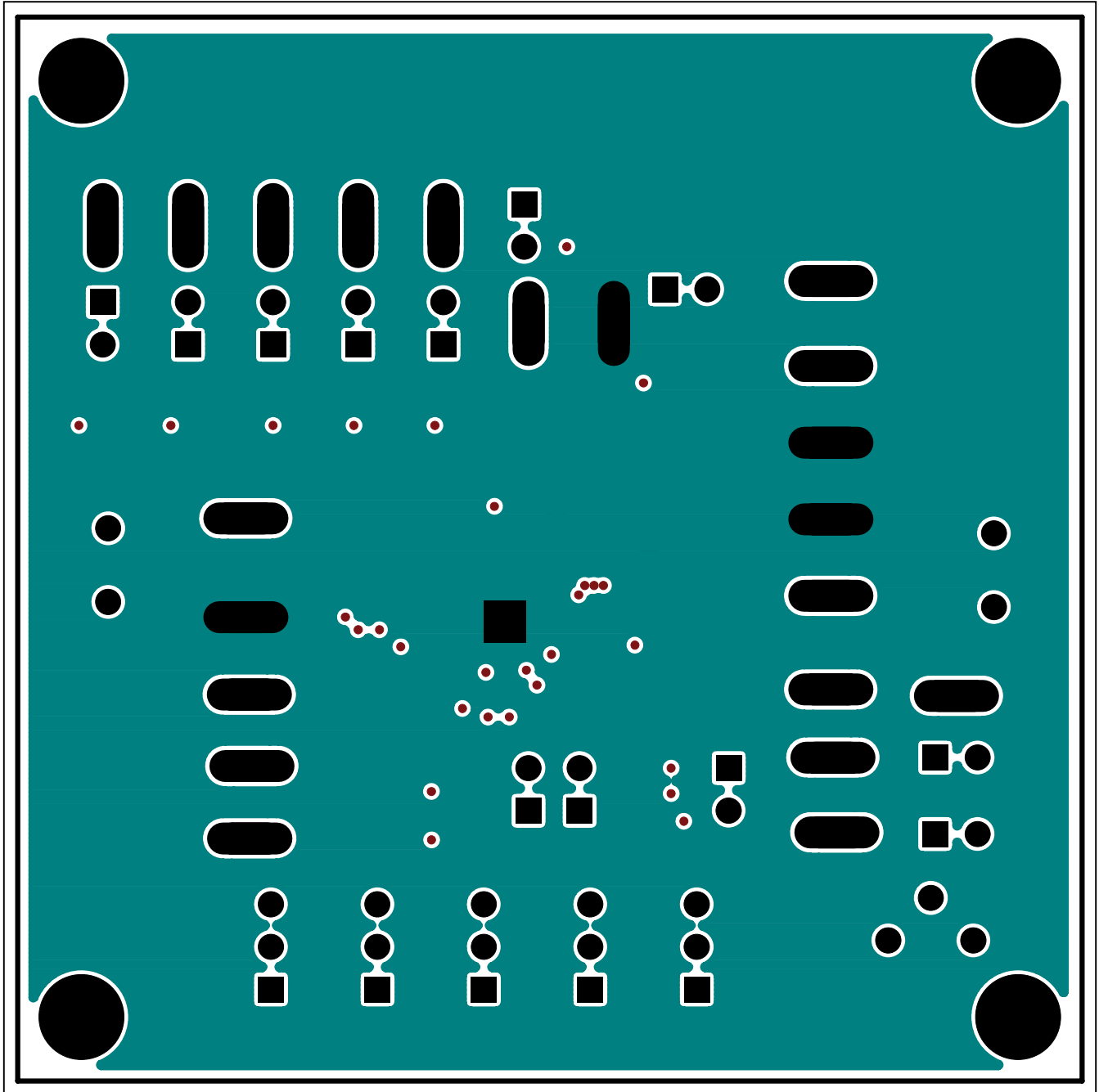

Figure 7. MAX8934A EV Kit PCB Layout—Inner Layer 3

MAX8934A Evaluation Kit

Evaluates: MAX8934A-MAX8934E

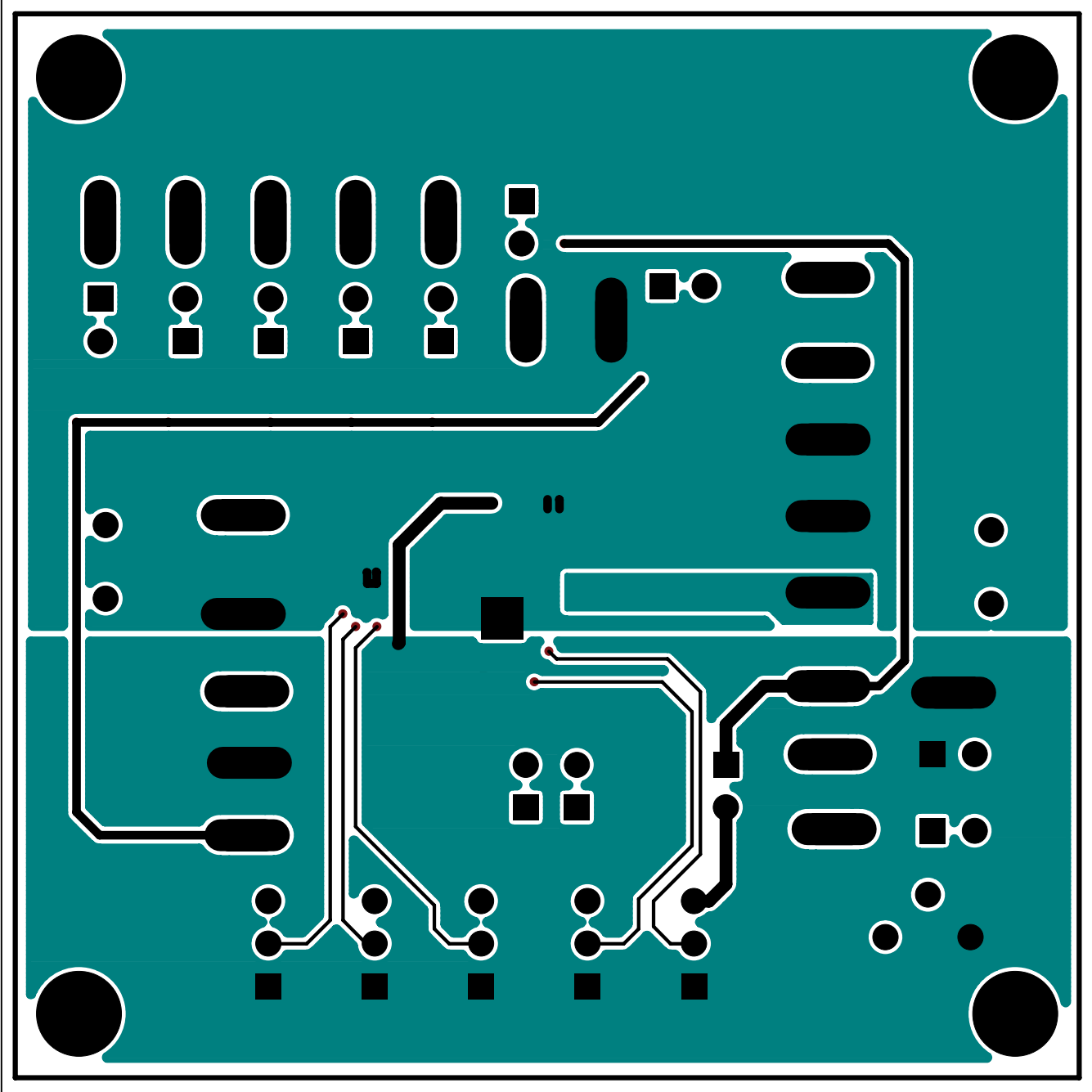

Figure 8. MAX8934A EV Kit PCB Layout—Bottom Layer

MAX8934A Evaluation Kit

Evaluates: MAX8934A-MAX8934E

Revision History

REVISION NUMBER	REVISION DATE	DESCRIPTION	PAGES CHANGED
0	6/10	Initial release	—
1	1/14	Added a ground symbol in Figure 3	9



Maxim Integrated cannot assume responsibility for use of any circuitry other than circuitry entirely embodied in a Maxim Integrated product. No circuit patent licenses are implied. Maxim Integrated reserves the right to change the circuitry and specifications without notice at any time. The parametric values (min and max limits) shown in the Electrical Characteristics table are guaranteed. Other parametric values quoted in this data sheet are provided for guidance.

Maxim Integrated 160 Rio Robles, San Jose, CA 95134 USA 1-408-601-1000

15

Компания «Океан Электроники» предлагает заключение долгосрочных отношений при поставках импортных электронных компонентов на взаимовыгодных условиях!

Наши преимущества:

- Поставка оригинальных импортных электронных компонентов напрямую с производств Америки, Европы и Азии, а так же с крупнейших складов мира;
- Широкая линейка поставок активных и пассивных импортных электронных компонентов (более 30 млн. наименований);
- Поставка сложных, дефицитных, либо снятых с производства позиций;
- Оперативные сроки поставки под заказ (от 5 рабочих дней);
- Экспресс доставка в любую точку России;
- Помощь Конструкторского Отдела и консультации квалифицированных инженеров;
- Техническая поддержка проекта, помощь в подборе аналогов, поставка прототипов;
- Поставка электронных компонентов под контролем ВП;
- Система менеджмента качества сертифицирована по Международному стандарту ISO 9001;
- При необходимости вся продукция военного и аэрокосмического назначения проходит испытания и сертификацию в лаборатории (по согласованию с заказчиком);
- Поставка специализированных компонентов военного и аэрокосмического уровня качества (Xilinx, Altera, Analog Devices, Intersil, Interpoint, Microsemi, Actel, Aeroflex, Peregrine, VPT, Syfer, Eurofarad, Texas Instruments, MS Kennedy, Miteq, Cobham, E2V, MA-COM, Hittite, Mini-Circuits, General Dynamics и др.);

Компания «Океан Электроники» является официальным дистрибьютором и эксклюзивным представителем в России одного из крупнейших производителей разъемов военного и аэрокосмического назначения «JONHON», а так же официальным дистрибьютором и эксклюзивным представителем в России производителя высокотехнологичных и надежных решений для передачи СВЧ сигналов «FORSTAR».



JONHON

«JONHON» (основан в 1970 г.)

Разъемы специального, военного и аэрокосмического назначения:

(Применяются в военной, авиационной, аэрокосмической, морской, железнодорожной, горно- и нефтедобывающей отраслях промышленности)

«FORSTAR» (основан в 1998 г.)

ВЧ соединители, коаксиальные кабели, кабельные сборки и микроволновые компоненты:

(Применяются в телекоммуникациях гражданского и специального назначения, в средствах связи, РЛС, а так же военной, авиационной и аэрокосмической отраслях промышленности).



Телефон: 8 (812) 309-75-97 (многоканальный)

Факс: 8 (812) 320-03-32

Электронная почта: ocean@oceanchips.ru

Web: <http://oceanchips.ru/>

Адрес: 198099, г. Санкт-Петербург, ул. Калинина, д. 2, корп. 4, лит. А