

## 10-Bit, Nonvolatile, Linear-Taper Digital Potentiometers

### General Description

The MAX5481–MAX5484 10-bit (1024-tap) nonvolatile, linear-taper, programmable voltage-dividers and variable resistors perform the function of a mechanical potentiometer, but replace the mechanics with a pin-configurable 3-wire serial SPI™-compatible interface or up/down digital interface. The MAX5481/MAX5482 are 3-terminal voltage-dividers and the MAX5483/MAX5484 are 2-terminal variable resistors.

The MAX5481–MAX5484 feature an internal, non-volatile, electrically erasable programmable read-only memory (EEPROM) that stores the wiper position for initialization during power-up. The 3-wire SPI-compatible serial interface allows communication at data rates up to 7MHz. A pin-selectable up/down digital interface is also available.

The MAX5481–MAX5484 are ideal for applications requiring digitally controlled potentiometers. Two end-to-end resistance values are available (10kΩ and 50kΩ) in a voltage-divider or a variable-resistor configuration (see the *Selector Guide*). The nominal resistor temperature coefficient is 35ppm/°C end-to-end, and only 5ppm/°C ratiometric, making these devices ideal for applications requiring low-temperature-coefficient voltage-dividers, such as low-drift, programmable gain-amplifiers.

The MAX5481–MAX5484 operate with either a +2.7V to +5.25V single power supply or ±2.5V dual power supplies. These devices consume 400μA (max) of supply current when writing data to the nonvolatile memory and 1.0μA (max) of standby supply current. The MAX5481–MAX5484 are available in a space-saving (3mm x 3mm), 16-pin TQFN, or a 14-pin TSSOP package and are specified over the extended (-40°C to +85°C) temperature range.

### Applications

Gain and Offset Adjustment	Low-Drift Programmable Gain Amplifiers
LCD Contrast Adjustment	Mechanical Potentiometer Replacement
Pressure Sensors	

### Ordering Information

PART	PIN-PACKAGE	TOP MARK
MAX5481ETE+	16 TQFN-EP*	ACP
MAX5481EUD+	14 TSSOP	—

**Note:** All devices are specified over the -40°C to +85°C operating temperature range.

+Denotes a lead(Pb)-free/RoHS-compliant package.

\*EP = Exposed pad.

Ordering Information continued at end of data sheet.

### Features

- ◆ 1024 Tap Positions
- ◆ Power-On Recall of Wiper Position from Nonvolatile Memory
- ◆ 16-Pin (3mm x 3mm x 0.8mm) TQFN or 14-Pin TSSOP Package
- ◆ 35ppm/°C End-to-End Resistance Temperature Coefficient
- ◆ 5ppm/°C Ratiometric Temperature Coefficient
- ◆ 10kΩ and 50kΩ End-to-End Resistor Values
- ◆ Pin-Selectable SPI-Compatible Serial Interface or Up/Down Digital Interface
- ◆ 1μA (max) Standby Current
- ◆ Single +2.7V to +5.25V Supply Operation
- ◆ Dual ±2.5V Supply Operation

### Pin Configurations

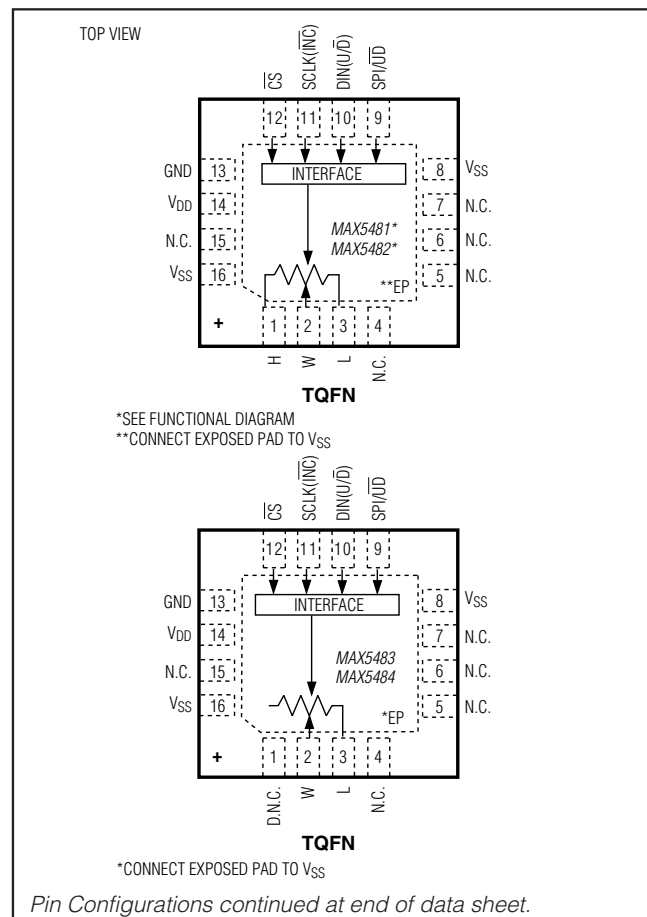

Selector Guide appears at end of data sheet.

SPI is a trademark of Motorola, Inc.

# MAX5481-MAX5484

## 10-Bit, Nonvolatile, Linear-Taper Digital Potentiometers

### ABSOLUTE MAXIMUM RATINGS

V <sub>DD</sub> to GND	-0.3V to +6.0V
V <sub>SS</sub> to GND	-3.5V to +0.3V
V <sub>DD</sub> to V <sub>SS</sub>	-0.3V to +6.0V
H, L, W to V <sub>SS</sub>	(V <sub>SS</sub> - 0.3V) to (V <sub>DD</sub> + 0.3V)
CS, SCLK(I $\bar{N}$ C), DIN(U $\bar{D}$ ), SPI/ $\bar{U}$ D to GND	-0.3V to (V <sub>DD</sub> + 0.3V)
Maximum Continuous Current into H, L, and W	
MAX5481/MAX5483	±5mA
MAX5482/MAX5484	±1.0mA
Maximum Current into Any Other Pin	±50mA

Continuous Power Dissipation (T <sub>A</sub> = +70°C)	
16-Pin TQFN (derate 17.5mW/°C above +70°C)	1398.6mW
14-Pin TSSOP (derate 9.1mW/°C above +70°C)	727mW
Operating Temperature Range	-40°C to +85°C
Junction Temperature	+150°C
Storage Temperature Range	-60°C to +150°C
Lead Temperature (soldering, 10s)	+300°C
Soldering Temperature (reflow)	+260°C

Stresses beyond those listed under "Absolute Maximum Ratings" may cause permanent damage to the device. These are stress ratings only, and functional operation of the device at these or any other conditions beyond those indicated in the operational sections of the specifications is not implied. Exposure to absolute maximum rating conditions for extended periods may affect device reliability.

### ELECTRICAL CHARACTERISTICS

(V<sub>DD</sub> = +2.7V to +5.25V, V<sub>SS</sub> = V<sub>GND</sub> = 0V, V<sub>H</sub> = V<sub>DD</sub>, V<sub>L</sub> = 0V, T<sub>A</sub> = -40°C to +85°C, unless otherwise noted. Typical values are at V<sub>DD</sub> = +5.0V, T<sub>A</sub> = +25°C, unless otherwise noted.) (Note 1)

PARAMETER	SYMBOL	CONDITIONS	MIN	TYP	MAX	UNITS
<b>DC PERFORMANCE (MAX5481/MAX5482 programmable voltage-divider)</b>						
Resolution	N		10			Bits
Integral Nonlinearity (Note 2)	INL	V <sub>DD</sub> = +2.7V			±2	LSB
		V <sub>DD</sub> = +5V			±2	
Differential Nonlinearity (Note 2)	DNL	V <sub>DD</sub> = +2.7V			±1	LSB
		V <sub>DD</sub> = +5V			±1	
End-to-End Resistance Temperature Coefficient	TC <sub>R</sub>			35		ppm/°C
Ratiometric Resistance Temperature Coefficient				5		ppm/°C
Full-Scale Error	FSE	MAX5481	-4	-2.5	0	LSB
		MAX5482	-4	-0.75	0	
Zero-Scale Error	ZSE	MAX5481	0	+3.3	+5	LSB
		MAX5482	0	+1.45	+5	
End-to-End Resistance	R <sub>H-L</sub>	MAX5481	7.5	10	12.5	kΩ
		MAX5482	37.5	50	62.5	
Wiper Capacitance	C <sub>W</sub>			60		pF
Resistance from W to L and H		W at code = 15, H and L shorted to V <sub>SS</sub> , measure resistance from W to H, Figures 1 and 2	MAX5481		6.3	kΩ
			MAX5482		25	
<b>DC PERFORMANCE (MAX5483/MAX5484 variable resistor)</b>						
Resolution	N		10			Bits
Integral Nonlinearity (Note 3)	INL <sub>R</sub>	V <sub>DD</sub> = +2.7V			-1.6	LSB
		V <sub>DD</sub> = +3V	-4	-1.4	+4	
		V <sub>DD</sub> = +5V	-4	-1.3	+4	
Differential Nonlinearity (Note 3)	DNL <sub>R</sub>	V <sub>DD</sub> = +2.7V			+0.45	LSB
		V <sub>DD</sub> = +3V	-1	+0.4	+1	
		V <sub>DD</sub> = +5V	-1	+0.35	+1	
Variable-Resistor Temperature Coefficient	TC <sub>VR</sub>	V <sub>DD</sub> = +3V to +5.25V; code = 128 to 1024		35		ppm/°C

# MAX5481-MAX5484

## 10-Bit, Nonvolatile, Linear-Taper Digital Potentiometers

### ELECTRICAL CHARACTERISTICS (continued)

( $V_{DD} = +2.7V$  to  $+5.25V$ ,  $V_{SS} = V_{GND} = 0V$ ,  $V_H = V_{DD}$ ,  $V_L = 0V$ ,  $T_A = -40^\circ C$  to  $+85^\circ C$ , unless otherwise noted. Typical values are at  $V_{DD} = +5.0V$ ,  $T_A = +25^\circ C$ , unless otherwise noted.) (Note 1)

PARAMETER	SYMBOL	CONDITIONS		MIN	TYP	MAX	UNITS
Full-Scale Wiper-to-End Resistance	$R_{W-L}$	MAX5483		7.5	10	12.5	$k\Omega$
		MAX5484		37.5	50	62.5	$k\Omega$
Zero-Scale Resistor Error	$R_Z$	Code = 0	MAX5483	70		$\Omega$	
			MAX5484	110			
Wiper Resistance	$R_W$	$V_{DD} \geq +3V$ (Note 4)		50		$\Omega$	
Wiper Capacitance	$C_W$			60		pF	
<b>DIGITAL INPUTS (<math>\overline{CS}</math>, <math>\overline{SCLK(INC)}</math>, <math>\overline{DIN(U/D)}</math>, <math>\overline{SPI(UD)}</math>) (Note 5)</b>							
Input-High Voltage	$V_{IH}$	Single-supply operation	$V_{DD} = +3.6V$ to $+5.25V$	2.4		V	
			$V_{DD} = +2.7V$ to $+3.6V$	$0.7 \times V_{DD}$			
		Dual-supply operation	$V_{DD} = +2.5V$ , $V_{SS} = -2.5V$	2.0			
Input-Low Voltage	$V_{IL}$	Single-supply operation	$V_{DD} = +2.7V$ to $+5.25V$	0.8		V	
		Dual-supply operation	$V_{DD} = +2.5V$ , $V_{SS} = -2.5V$	0.6			
Input Leakage Current	$I_{IN}$			$\pm 1$		$\mu A$	
Input Capacitance	$C_{IN}$			5		pF	
<b>DYNAMIC CHARACTERISTICS</b>							
Wiper -3dB Bandwidth		Wiper at code = 01111 01111, $C_{LW} = 10pF$	MAX5481	250		kHz	
			MAX5482	50			
Total Harmonic Distortion	THD	$V_{DD} = +3V$ , wiper at code = 01111 01111, $1V_{RMS}$ at 10kHz is applied at H, 10pF load on W	MAX5481	0.026		%	
			MAX5482	0.03			
<b>NONVOLATILE MEMORY RELIABILITY</b>							
Data Retention		$T_A = +85^\circ C$		50		Years	
Endurance		$T_A = +25^\circ C$		200,000		Stores	
		$T_A = +85^\circ C$		50,000			
<b>POWER SUPPLY</b>							
Single-Supply Voltage	$V_{DD}$	$V_{SS} = V_{GND} = 0V$		2.70	5.25		V
Dual-Supply Voltage	$V_{DD}$	$V_{GND} = 0V$		2.50	5.25		V
	$V_{SS}$	$V_{DD} - V_{SS} \leq +5.25V$		-2.5	-0.2		
Average Programming Current	$I_{PG}$	During nonvolatile write; digital inputs = $V_{DD}$ or GND		220	400		$\mu A$
Peak Programming Current		During nonvolatile write only; digital inputs = $V_{DD}$ or GND		4		mA	
Standby Current	$I_{DD}$	Digital inputs = $V_{DD}$ or GND, $T_A = +25^\circ C$		0.6	1		$\mu A$

# MAX5481-MAX5484

## 10-Bit, Nonvolatile, Linear-Taper Digital Potentiometers

### TIMING CHARACTERISTICS

( $V_{DD} = +2.7V$  to  $+5.25V$ ,  $V_{SS} = V_{GND} = 0V$ ,  $V_H = V_{DD}$ ,  $V_L = 0V$ ,  $T_A = -40^\circ C$  to  $+85^\circ C$ , unless otherwise noted. Typical values are at  $V_{DD} = +5.0V$ ,  $T_A = +25^\circ C$ , unless otherwise noted.) (Note 1)

PARAMETER	SYMBOL	CONDITIONS	MIN	TYP	MAX	UNITS
<b>ANALOG SECTION</b>						
Wiper Settling Time (Note 6)	t <sub>s</sub>	MAX5481		5		μs
		MAX5482		22		
<b>SPI-COMPATIBLE SERIAL INTERFACE</b> (Figure 3)						
SCLK Frequency	f <sub>SCLK</sub>				7	MHz
SCLK Clock Period	t <sub>CP</sub>		140			ns
SCLK Pulse-Width High	t <sub>CH</sub>		60			ns
SCLK Pulse-Width Low	t <sub>CL</sub>		60			ns
$\overline{CS}$ Fall to SCLK Rise Setup	t <sub>CSS</sub>		60			ns
SCLK Rise to $\overline{CS}$ Rise Hold	t <sub>CSH</sub>		0			ns
DIN to SCLK Setup	t <sub>DS</sub>		40			ns
DIN Hold after SCLK	t <sub>DH</sub>		0			ns
SCLK Rise to $\overline{CS}$ Fall Delay	t <sub>CS0</sub>		15			ns
$\overline{CS}$ Rise to SCLK Rise Hold	t <sub>CS1</sub>		60			ns
$\overline{CS}$ Pulse-Width High	t <sub>CSW</sub>		150			ns
Write NV Register Busy Time	t <sub>BUSY</sub>				12	ms
<b>UP/DOWN DIGITAL INTERFACE</b> (Figure 8)						
$\overline{CS}$ to $\overline{INC}$ Setup	t <sub>CI</sub>		25			ns
$\overline{INC}$ High to U/ $\overline{D}$ Change	t <sub>ID</sub>		20			ns
U/ $\overline{D}$ to $\overline{INC}$ Setup	t <sub>DI</sub>		25			ns
$\overline{INC}$ Low Period	t <sub>IL</sub>		25			ns
$\overline{INC}$ High Period	t <sub>IH</sub>		25			ns
$\overline{INC}$ Inactive to $\overline{CS}$ Inactive	t <sub>IC</sub>		50			ns
$\overline{CS}$ Deselect Time (Store)	t <sub>CPH</sub>		50			ns
$\overline{INC}$ Cycle Time	t <sub>CYC</sub>		50			ns
$\overline{INC}$ Active to $\overline{CS}$ Inactive	t <sub>IK</sub>		50			ns
Wiper Store Cycle	t <sub>WSC</sub>				12	ms

**Note 1:** 100% production tested at  $T_A = +25^\circ C$  and  $T_A = +85^\circ C$ . Guaranteed by design to  $T_A = -40^\circ C$ .

**Note 2:** The DNL and INL are measured with the device configured as a voltage-divider with  $H = V_{DD}$  and  $L = V_{SS}$ . The wiper terminal (W) is unloaded and measured with a high-input-impedance voltmeter.

**Note 3:** The DNL<sub>R</sub> and INL<sub>R</sub> are measured with D.N.C. unconnected and  $L = V_{SS} = 0V$ . For  $V_{DD} = +5V$ , the wiper terminal is driven with a source current of  $I_W = 80\mu A$  for the 50k $\Omega$  device and 400 $\mu A$  for the 10k $\Omega$  device. For  $V_{DD} = +3V$ , the wiper terminal is driven with a source current of 40 $\mu A$  for the 50k $\Omega$  device and 200 $\mu A$  for the 10k $\Omega$  device.

**Note 4:** The wiper resistance is measured using the source currents given in Note 3.

**Note 5:** The device draws higher supply current when the digital inputs are driven with voltages between ( $V_{DD} - 0.5V$ ) and ( $V_{GND} + 0.5V$ ). See Supply Current vs. Digital Input Voltage in the *Typical Operating Characteristics*.

**Note 6:** Wiper settling test condition uses the voltage-divider configuration with a 10pF load on W. Transition code from 00000 00000 to 01111 01111 and measure the time from  $\overline{CS}$  going high to the wiper voltage settling to within 0.5% of its final value.

# MAX5481-MAX5484

## 10-Bit, Nonvolatile, Linear-Taper Digital Potentiometers

### Typical Operating Characteristics

( $V_{DD} = 5.0V$ ,  $V_{SS} = 0V$ ,  $T_A = +25^\circ C$ , unless otherwise noted.)

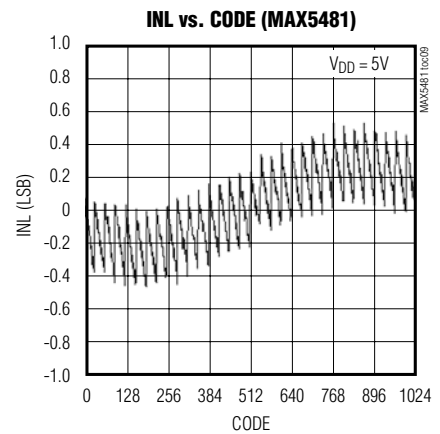
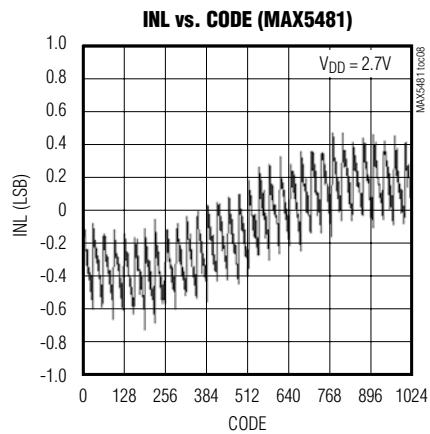
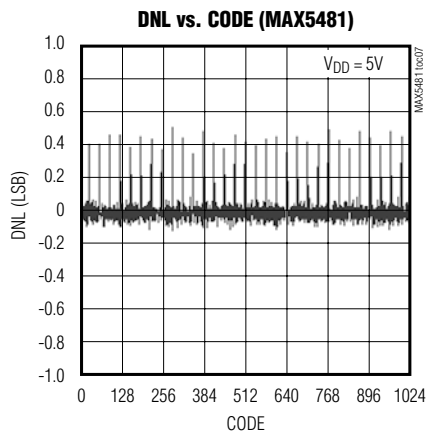
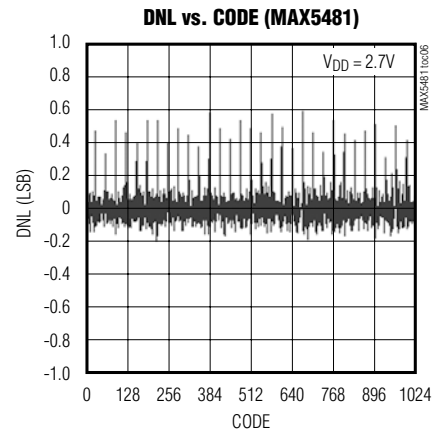
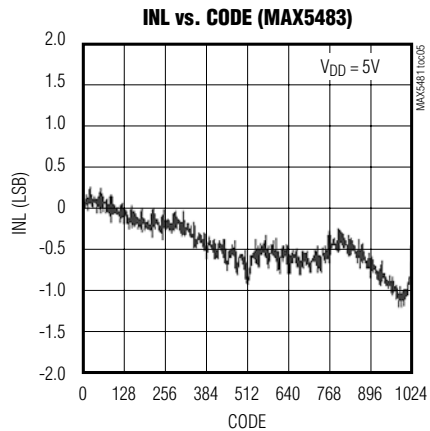
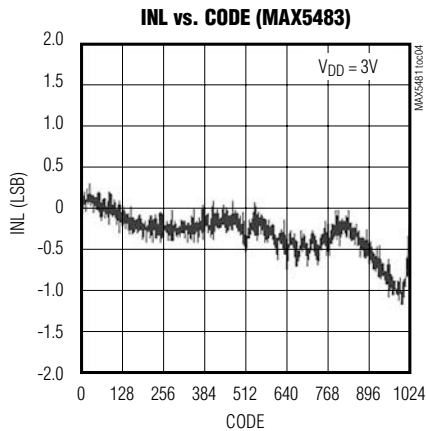
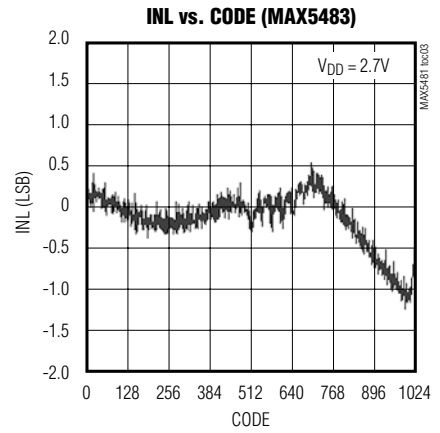
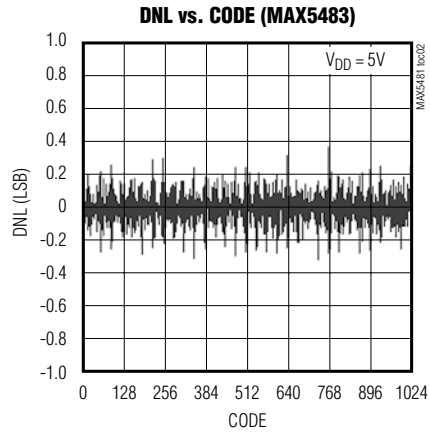
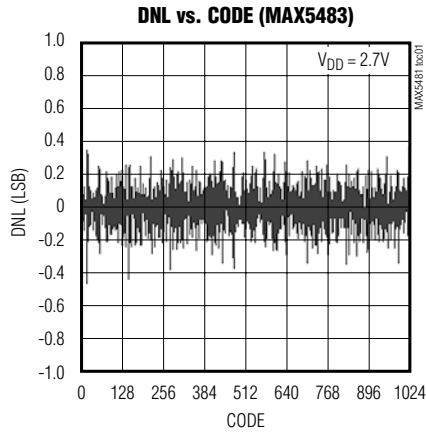

# MAX5481-MAX5484

## 10-Bit, Nonvolatile, Linear-Taper Digital Potentiometers

### Typical Operating Characteristics (continued)

( $V_{DD} = 5.0V$ ,  $V_{SS} = 0V$ ,  $T_A = +25^\circ C$ , unless otherwise noted.)

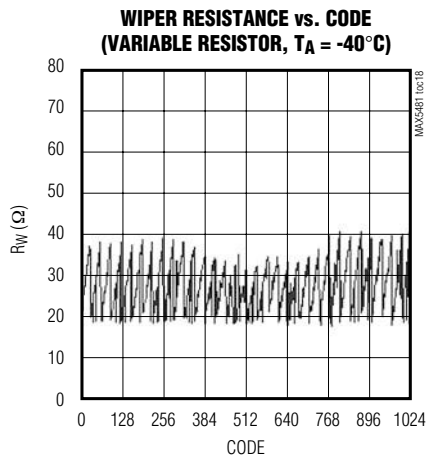
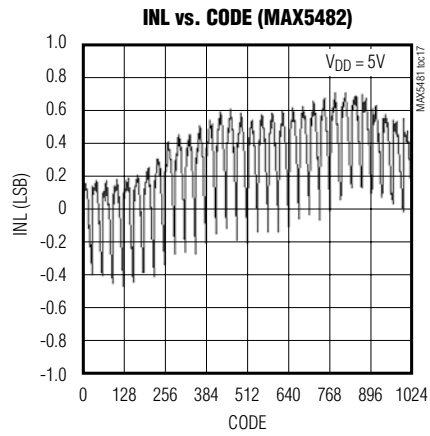
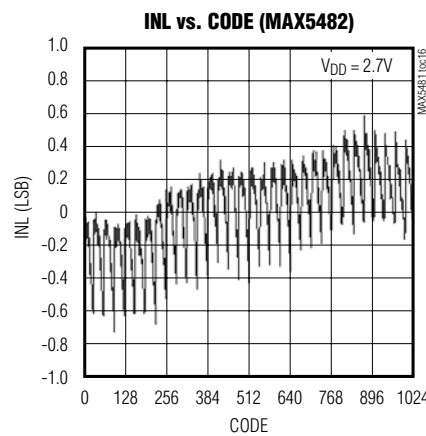
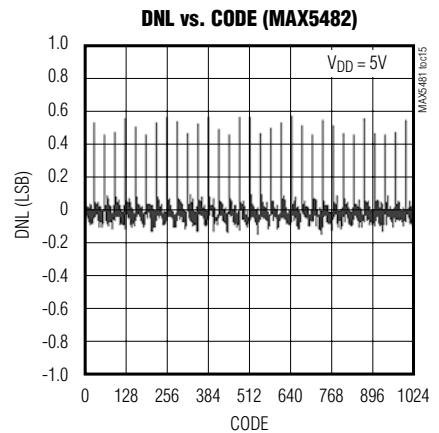
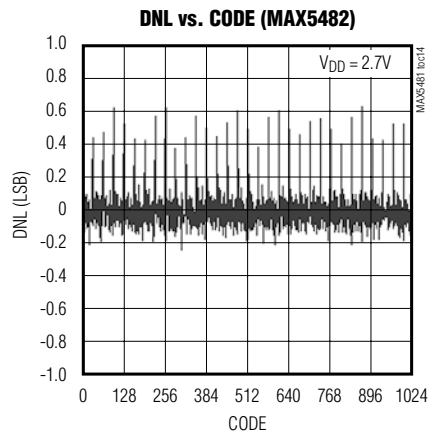
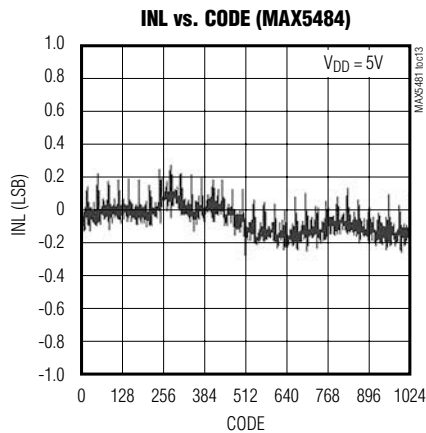
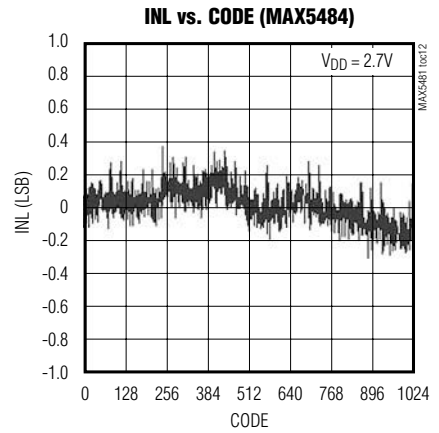
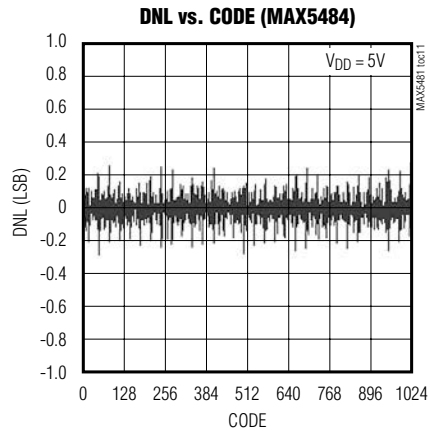
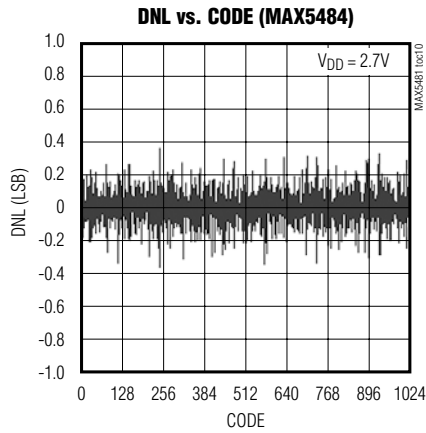

# MAX5481-MAX5484

## 10-Bit, Nonvolatile, Linear-Taper Digital Potentiometers

### Typical Operating Characteristics (continued)

( $V_{DD} = 5.0V$ ,  $V_{SS} = 0V$ ,  $T_A = +25^\circ C$ , unless otherwise noted.)

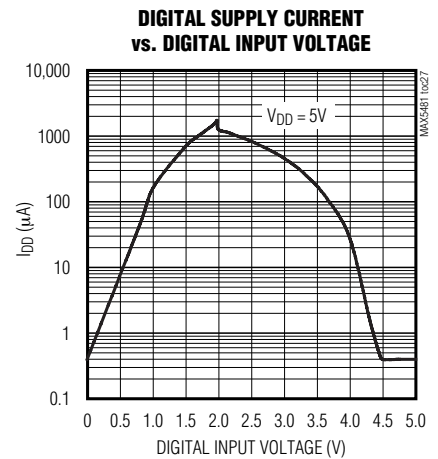
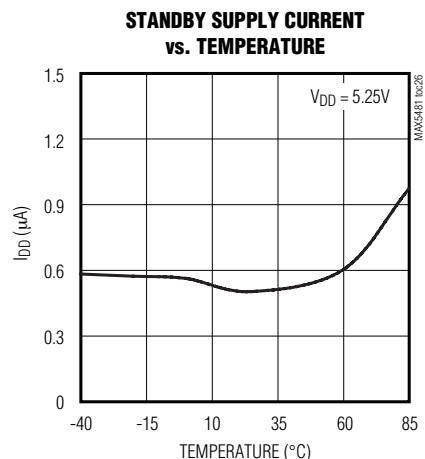
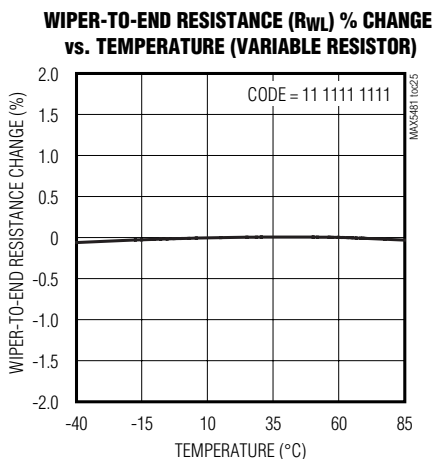
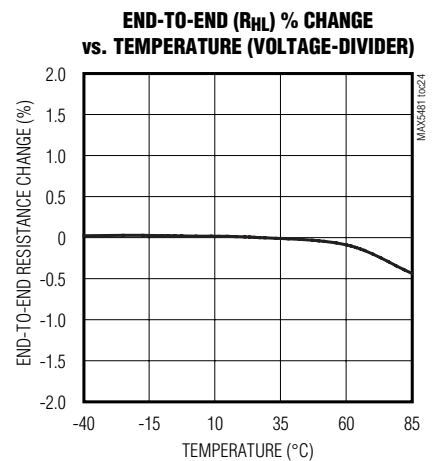
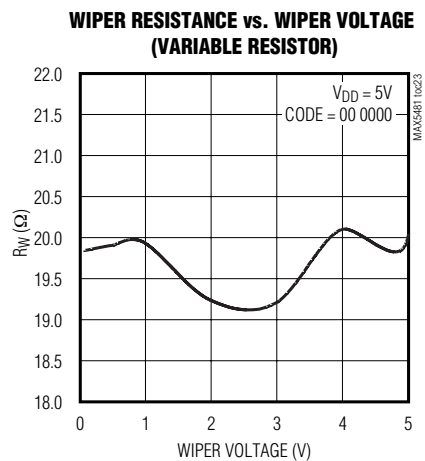
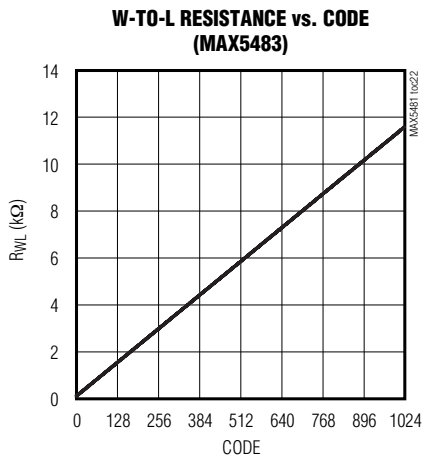
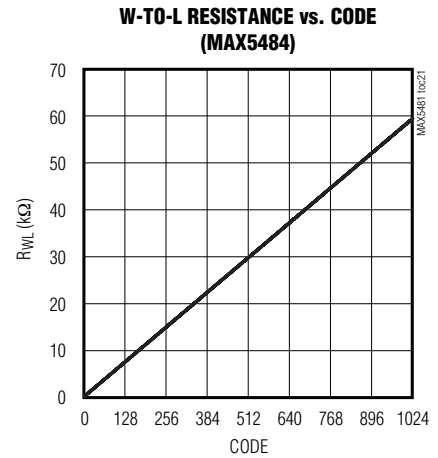
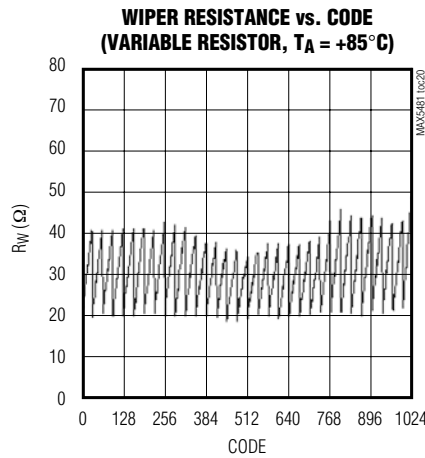
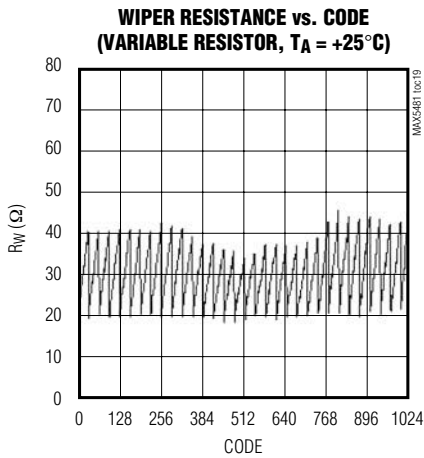

# MAX5481-MAX5484

## 10-Bit, Nonvolatile, Linear-Taper Digital Potentiometers

### Typical Operating Characteristics (continued)

(Circuit of Figure 1,  $T_A = +25^\circ\text{C}$ , unless otherwise noted.)

**TAP-TO-TAP SWITCHING TRANSIENT RESPONSE (MAX5481)**

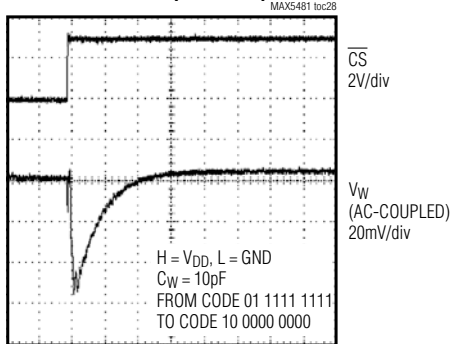

1  $\mu\text{s}/\text{div}$

**TAP-TO-TAP SWITCHING TRANSIENT RESPONSE (MAX5482)**

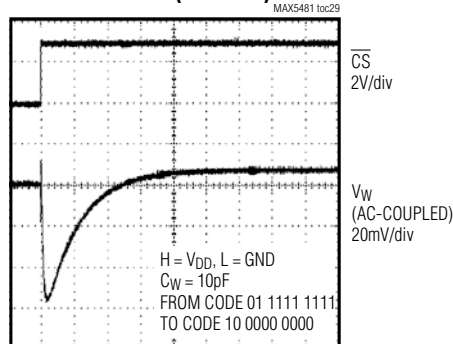

4  $\mu\text{s}/\text{div}$

**WIPER RESPONSE vs. FREQUENCY (MAX5481)**

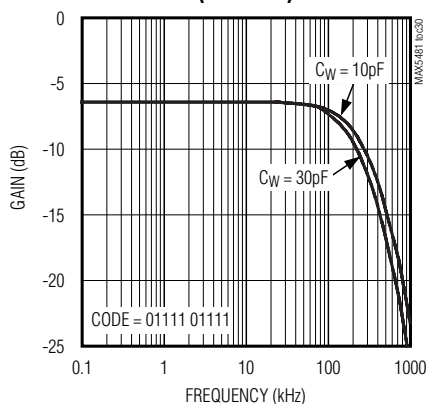

**WIPER RESPONSE vs. FREQUENCY (MAX5482)**

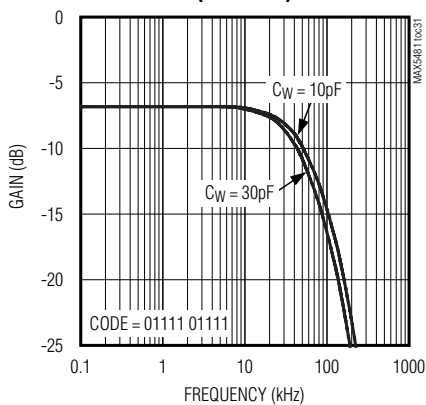

**THD+N vs. FREQUENCY (MAX5481)**

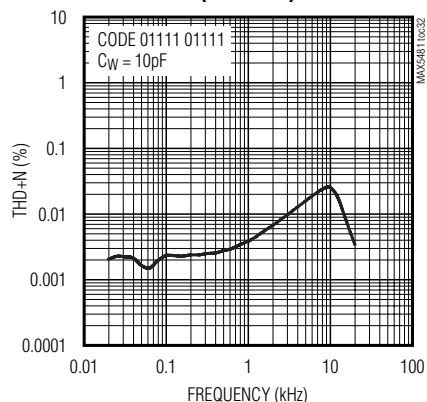

**THD+N vs. FREQUENCY (MAX5482)**

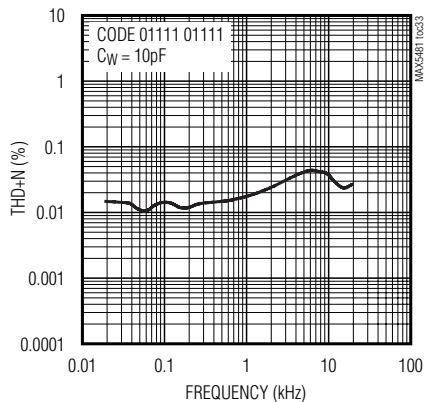

**RATIOMETRIC TEMPERATURE COEFFICIENT vs. CODE**

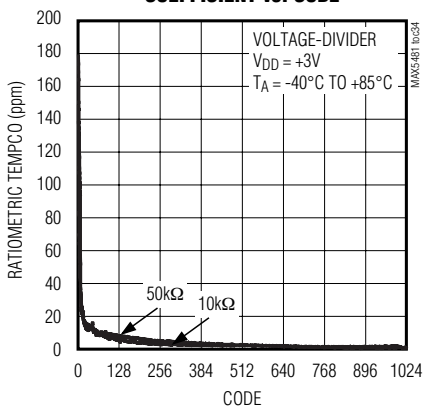

**VARIABLE-RESISTOR TEMPERATURE COEFFICIENT vs. CODE**

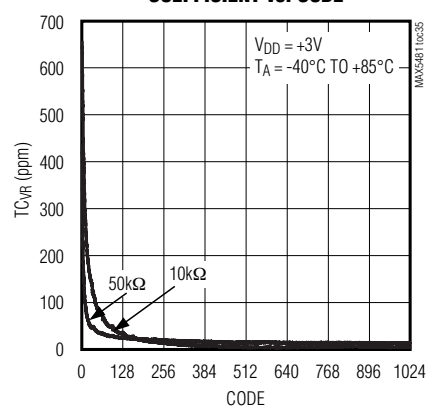



# MAX5481-MAX5484

## 10-Bit, Nonvolatile, Linear-Taper Digital Potentiometers

### Pin Description

#### (MAX5481/MAX5482 Voltage-Dividers)

PIN		NAME	FUNCTION
TQFN	TSSOP		
1	12	H	High Terminal
2	11	W	Wiper Terminal
3	10	L	Low Terminal
4-7, 15	7, 8, 9, 13	N.C.	No Connection. Not internally connected.
8, 16	14	V <sub>SS</sub>	Negative Power-Supply Input. For single-supply operation, connect V <sub>SS</sub> to GND. For dual-supply operation, $-2.5V \leq V_{SS} \leq -0.2V$ as long as $(V_{DD} - V_{SS}) \leq +5.25V$ . Bypass V <sub>SS</sub> to GND with a 0.1 $\mu$ F ceramic capacitor as close to the device as possible.
9	6	SPI/ $\overline{UD}$	Interface-Mode Select. Select serial SPI interface when SPI/ $\overline{UD}$ = 1. Select serial up/down interface when SPI/ $\overline{UD}$ = 0.
10	5	DIN(U/ $\overline{D}$ )	Serial SPI Interface Data Input (SPI/ $\overline{UD}$ = 1)
			Up/Down Control Input (SPI/ $\overline{UD}$ = 0). With DIN(U/ $\overline{D}$ ) low, a high-to-low SCLK( $\overline{INC}$ ) transition decrements the wiper position. With DIN(U/ $\overline{D}$ ) high, a high-to-low SCLK( $\overline{INC}$ ) transition increments the wiper position.
11	4	SCLK( $\overline{INC}$ )	Serial SPI Interface Clock Input (SPI/ $\overline{UD}$ = 1)
			Wiper-Increment Control Input (SPI/ $\overline{UD}$ = 0). With $\overline{CS}$ low, the wiper position moves in the direction determined by the state of DIN(U/ $\overline{D}$ ) on a high-to-low transition.
12	3	$\overline{CS}$	Active-Low Digital Input Chip Select
13	2	GND	Ground
14	1	V <sub>DD</sub>	Positive Power-Supply Input ( $+2.7V \leq V_{DD} \leq +5.25V$ ). Bypass V <sub>DD</sub> to GND with a 0.1 $\mu$ F ceramic capacitor as close to the device as possible.
—	—	EP	Exposed Pad (TQFN Only). Externally connect EP to V <sub>SS</sub> or leave unconnected.

# MAX5481–MAX5484

## 10-Bit, Nonvolatile, Linear-Taper Digital Potentiometers

### Pin Description (continued)

#### (MAX5483/MAX5484 Variable Resistors)

PIN		NAME	FUNCTION
TQFN	TSSOP		
4–7, 15	7, 8, 9, 13	N.C.	No Connection. Not internally connected.
1	12	D.N.C.	Do Not Connect. Leave unconnected for proper operation.
2	11	W	Wiper Terminal
3	10	L	Low Terminal
8, 16	14	V <sub>SS</sub>	Negative Power-Supply Input. For single-supply operation, connect V <sub>SS</sub> to GND. For dual-supply operation, $-2.5V \leq V_{SS} \leq -0.2V$ as long as $(V_{DD} - V_{SS}) \leq 5.25V$ . Bypass V <sub>SS</sub> to GND with a 0.1µF ceramic capacitor as close to the device as possible.
9	6	SPI/ $\overline{UD}$	Interface-Mode Select. Select serial SPI interface when SPI/ $\overline{UD}$ = 1. Select serial up/down interface when SPI/ $\overline{UD}$ = 0.
10	5	DIN( $\overline{UD}$ )	Serial SPI Interface Data Input (SPI/ $\overline{UD}$ = 1)
			Up/Down Control Input (SPI/ $\overline{UD}$ = 0). With DIN( $\overline{UD}$ ) low, a high-to-low SCLK( $\overline{INC}$ ) transition decrements the wiper position. With DIN( $\overline{UD}$ ) high, a high-to-low SCLK( $\overline{INC}$ ) transition increments the wiper position.
11	4	SCLK( $\overline{INC}$ )	Serial SPI Interface Clock Input (SPI/ $\overline{UD}$ = 1)
			Wiper Increment Control Input (SPI/ $\overline{UD}$ = 0). With $\overline{CS}$ low, the wiper position moves in the direction determined by the state of DIN( $\overline{UD}$ ) on a high-to-low transition.
12	3	$\overline{CS}$	Active-Low Digital Input Chip Select
13	2	GND	Ground
14	1	V <sub>DD</sub>	Positive Power-Supply Input ( $+2.7V \leq V_{DD} \leq +5.25V$ ). Bypass V <sub>DD</sub> to GND with a 0.1µF ceramic capacitor as close to the device as possible.
—	—	EP	Exposed Pad (TQFN Only). Externally connect EP to V <sub>SS</sub> or leave unconnected.

# MAX5481-MAX5484

## 10-Bit, Nonvolatile, Linear-Taper Digital Potentiometers

### Functional Diagrams

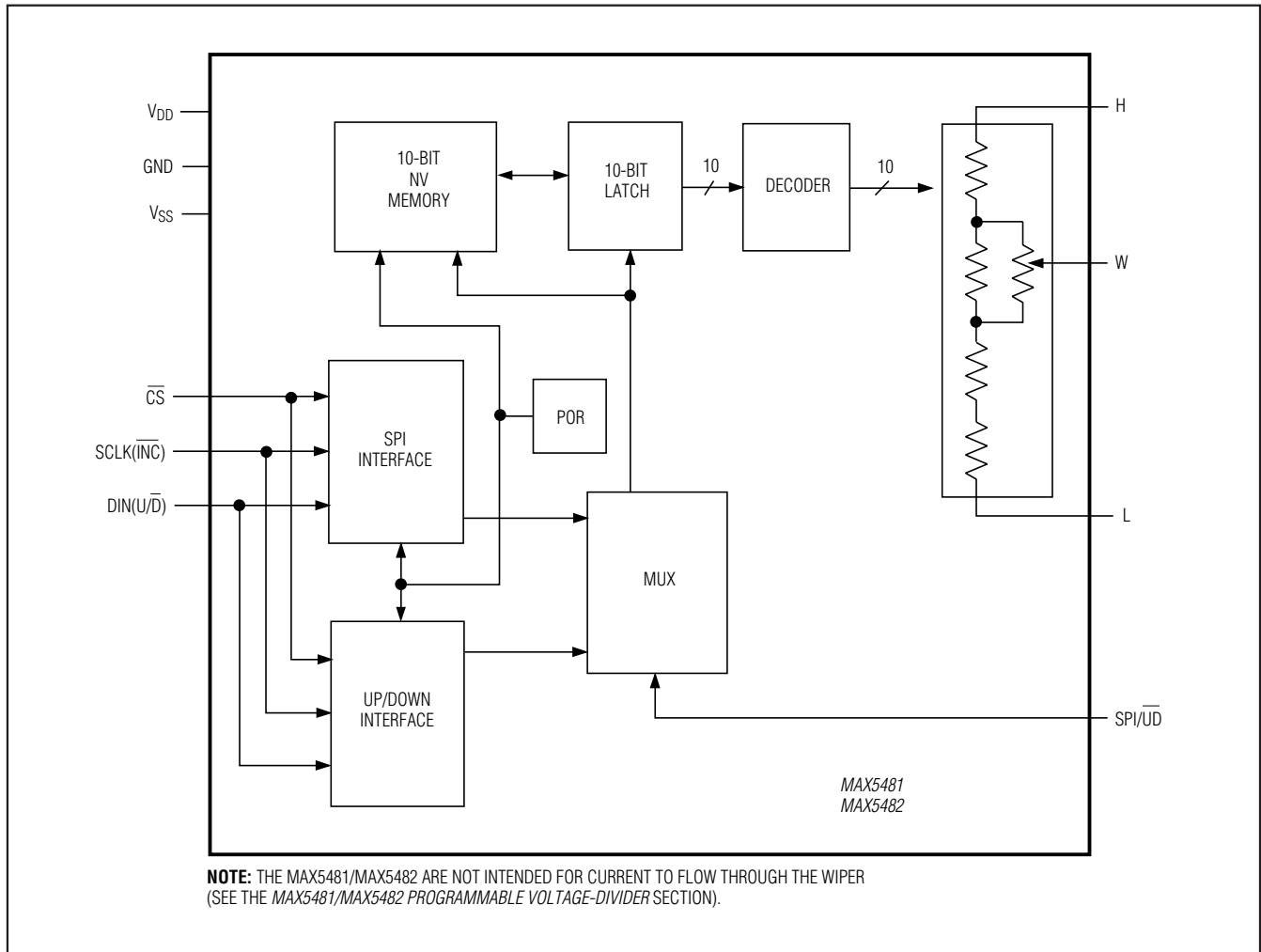

# MAX5481-MAX5484

## 10-Bit, Nonvolatile, Linear-Taper Digital Potentiometers

### Functional Diagrams (continued)

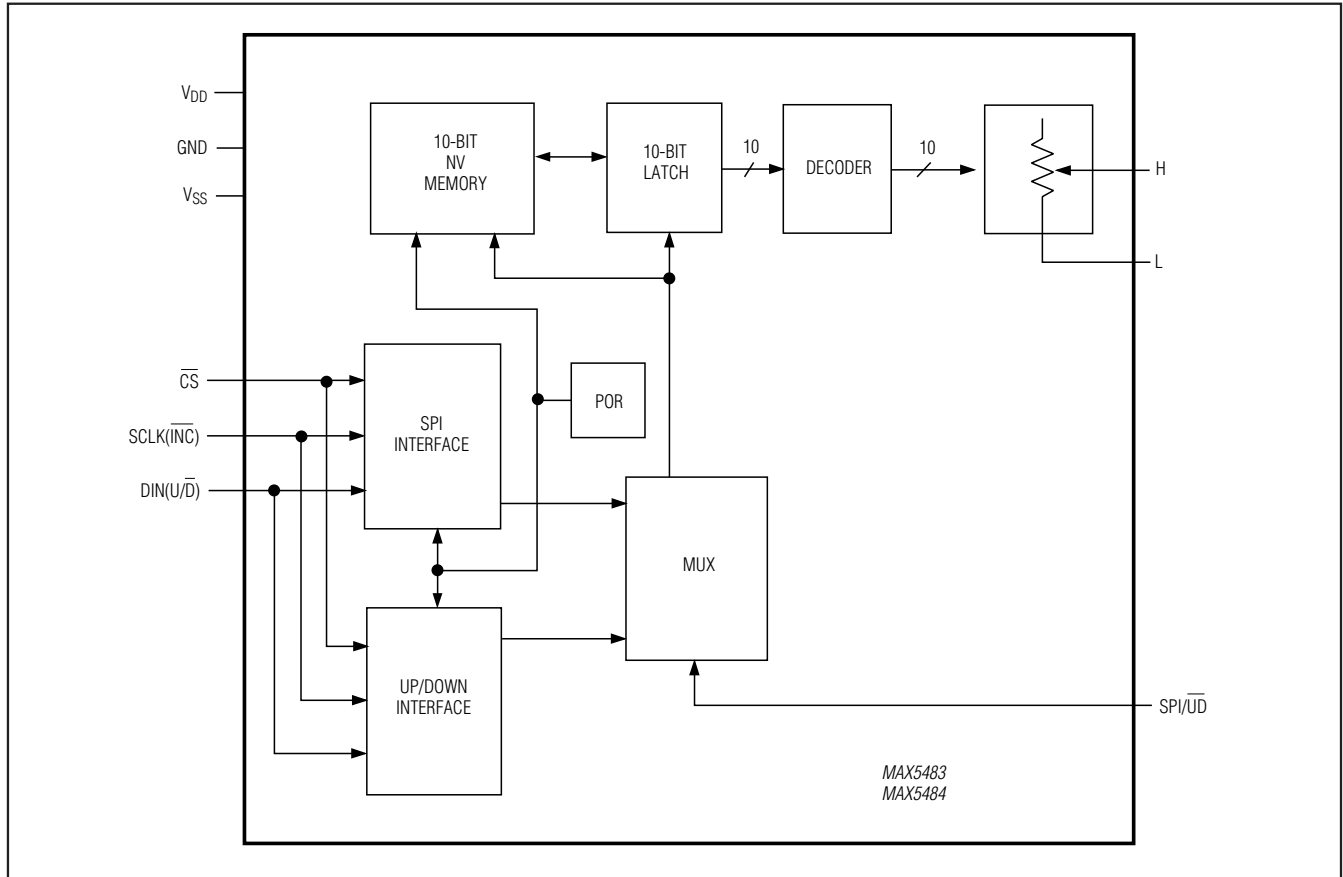

### Detailed Description

The MAX5481/MAX5482 linear programmable voltage-dividers and the MAX5483/MAX5484 variable resistors feature 1024 tap points (10-bit resolution) (see the *Functional Diagrams*). These devices consist of multiple strings of equal resistor segments with a wiper contact that moves among the 1024 points through a pin-selectable 3-wire SPI-compatible serial interface or up/down interface. The MAX5481/MAX5483 provide a total end-to-end resistance of 10k $\Omega$ , and the MAX5482/MAX5484 have an end-to-end resistance of 50k $\Omega$ . The MAX5481/MAX5482 allow access to the high, low, and wiper terminals for a standard voltage-divider configuration.

### MAX5481/MAX5482 Programmable Voltage-Dividers

The MAX5481/MAX5482 programmable voltage-dividers provide a weighted average of the voltage between the H and L inputs at the W output. Both devices feature 10-bit resolution and provide up to 1024 tap points between the H and L voltages. Ideally, the  $V_L$  voltage occurs at the wiper terminal (W) when all data bits are zero and the  $V_H$  voltage occurs at the wiper terminal when all data bits are one. The step size (1 LSB) voltage is equal to the voltage applied across terminals H and L divided by  $2^{10}$ . Calculate the wiper voltage  $V_W$  as follows:

$$V_W(D) = D \left[ \frac{V_{HL} - (|V_{FSE}| + |V_{ZSE}|)}{1023} \right] + V_L + |V_{ZSE}|$$

# MAX5481–MAX5484

## 10-Bit, Nonvolatile, Linear-Taper Digital Potentiometers

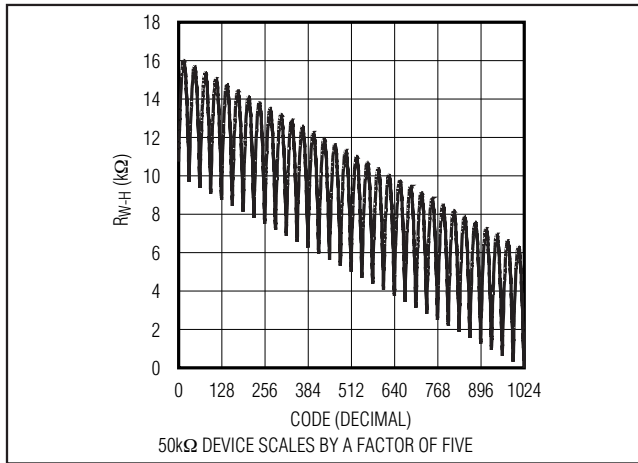

Figure 1. Resistance from W to H vs. Code (10kΩ Voltage-Divider)

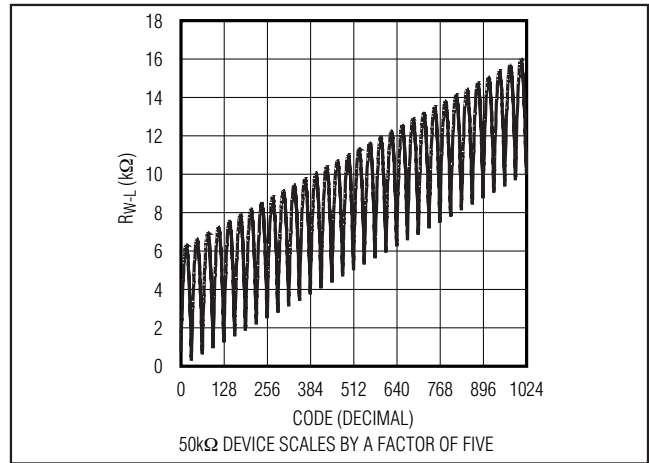

Figure 2. Resistance from W to L vs. Code (10kΩ Voltage-Divider)

where D is the decimal equivalent of the 10 data bits written (0 to 1023),  $V_{HL}$  is the voltage difference between the H and L terminals:

$$V_{FSE} = FSE \left[ \frac{V_{HL}}{1024} \right], \text{ and}$$

$$V_{ZSE} = ZSE \left[ \frac{V_{HL}}{1024} \right]$$

The MAX5481 includes a total end-to-end resistance value of 10kΩ while the MAX5482 features an end-to-end resistance value of 50kΩ. **These devices are not intended to be used as a variable resistor.** Wiper current creates a nonlinear voltage drop in series with the wiper. To ensure temperature drift remains within specifications, do not pull current through the voltage-divider wiper. Connect the wiper to a high-impedance node. Figures 1 and 2 show the behavior of the MAX5481's resistance from W to H and from W to L. This does not apply to the variable-resistor devices

### MAX5483/MAX5484 Variable Resistors

The MAX5483/MAX5484 provide a programmable resistance between W and L. The MAX5483 features a total end-to-end resistance value of 10kΩ, while the MAX5484 provides an end-to-end resistance value of 50kΩ. The programmable resolution of this resistance is equal to the nominal end-to-end resistance divided by 1024 (10-bit resolution). For example, each nominal segment resistance is 9.8Ω and 48.8Ω for the MAX5483 and the MAX5484, respectively.

Table 1.  $R_{WL}$  at Selected Codes

CODE (DECIMAL)	MAX5483 (10kΩ DEVICE)	MAX5484 (50kΩ DEVICE)
	$R_{WL}$ (Ω)	$R_{WL}$ (Ω)
0	70	110
1	80	160
512	5070	25,110
1023	10,070	50,110

The 10-bit data in the 10-bit latch register selects a wiper position from the 1024 possible positions, resulting in 1024 values for the resistance from W to L. Calculate the resistance from W to L ( $R_{WL}$ ) by using the following formula:

$$R_{WL}(D) = \frac{D}{1023} \times R_{W-L} + R_Z$$

where D is decimal equivalent of the 10 data bits written,  $R_{W-L}$  is the nominal end-to-end resistance, and  $R_Z$  is the zero-scale error. Table 1 shows the values of  $R_{WL}$  at selected codes for the MAX5483/MAX5484.

### Digital Interface

Configure the MAX5481–MAX5484 by a pin-selectable, 3-wire, SPI-compatible serial data interface or an up/down interface. Drive SPI/ $\overline{UD}$  high to select the 3-wire SPI-compatible interface. Pull SPI/ $\overline{UD}$  low to select the up/down interface.

# MAX5481-MAX5484

## 10-Bit, Nonvolatile, Linear-Taper Digital Potentiometers

Table 2. Command Decoding\*

CLOCK EDGE	1	2	3	4	5	6	7	8	9	10	11	12	13	14	15	16	17	18	19	...	24
Bit Name	—	—	C1	C0	—	—	—	—	D9	D8	D7	D6	D5	D4	D3	D2	D1	D0	—	...	—
Write Wiper Register	0	0	0	0	0	0	0	0	D9	D8	D7	D6	D5	D4	D3	D2	D1	D0	X	...	X
Copy Wiper Register to NV Register	0	0	1	0	0	0	0	0	—	—	—	—	—	—	—	—	—	—	—	...	—
Copy NV Register to Wiper Register	0	0	1	1	0	0	0	0	—	—	—	—	—	—	—	—	—	—	—	...	—

\*D9 is the MSB and D0 is the LSB.  
X = Don't care.

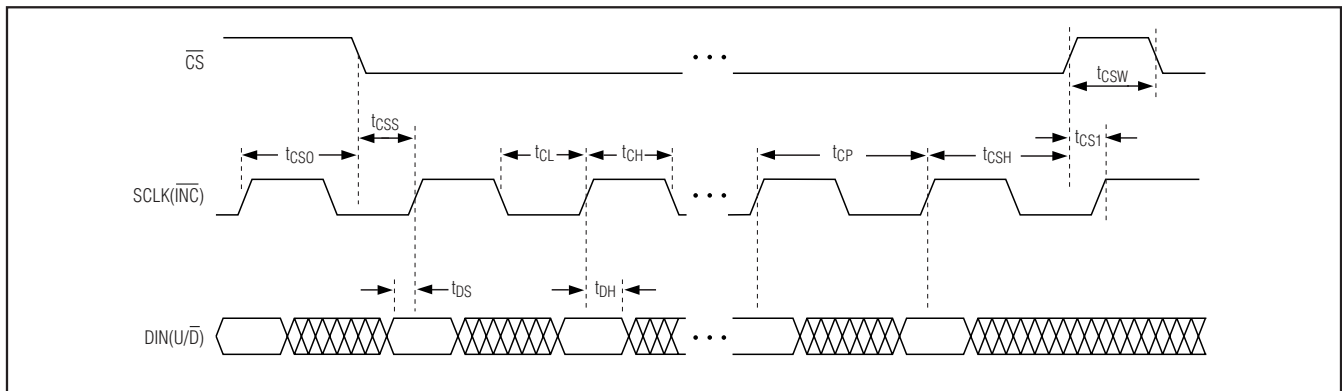

Figure 3. SPI-Compatible Serial-Interface Timing Diagram (SPI/UD = 1)

### SPI-Compatible Serial Interface

Drive SPI/UD high to enable the 3-wire SPI-compatible serial interface (see Figure 3). This write-only interface contains three inputs: chip select ( $\overline{CS}$ ), data in (DIN(U/D)), and data clock (SCLK(INC)). Drive  $\overline{CS}$  low to load the data at DIN(U/D) synchronously into the shift register on each SCLK(INC) rising edge.

The WRITE command (C1, C0 = 00) requires 24 clock cycles to transfer the command and data (Figure 4a). The COPY commands (C1, C0 = 10 or 11) use either eight clock cycles to transfer the command bits (Figure 4b) or 24 clock cycles with the last 16 data bits disregarded by the device.

After loading the data into the shift register, drive  $\overline{CS}$  high to latch the data into the appropriate control register. Keep  $\overline{CS}$  low during the entire serial data stream to avoid corruption of the data. Table 2 shows the command decoding.

### Write Wiper Register

Data written to this register (C1, C0 = 00) controls the wiper position. The 10 data bits (D9–D0) indicate the position of the wiper. For example, if DIN(U/D) = 00 0000 0000, the wiper moves to the position closest to L. If DIN(U/D) = 11 1111 1111, the wiper moves closest to H.

This command writes data to the volatile random access memory (RAM), leaving the NV register unchanged. When the device powers up, the data stored in the NV register transfers to the wiper register, moving the wiper to the stored position. Figure 5 shows how to write data to the wiper register.

# MAX5481-MAX5484

## 10-Bit, Nonvolatile, Linear-Taper Digital Potentiometers

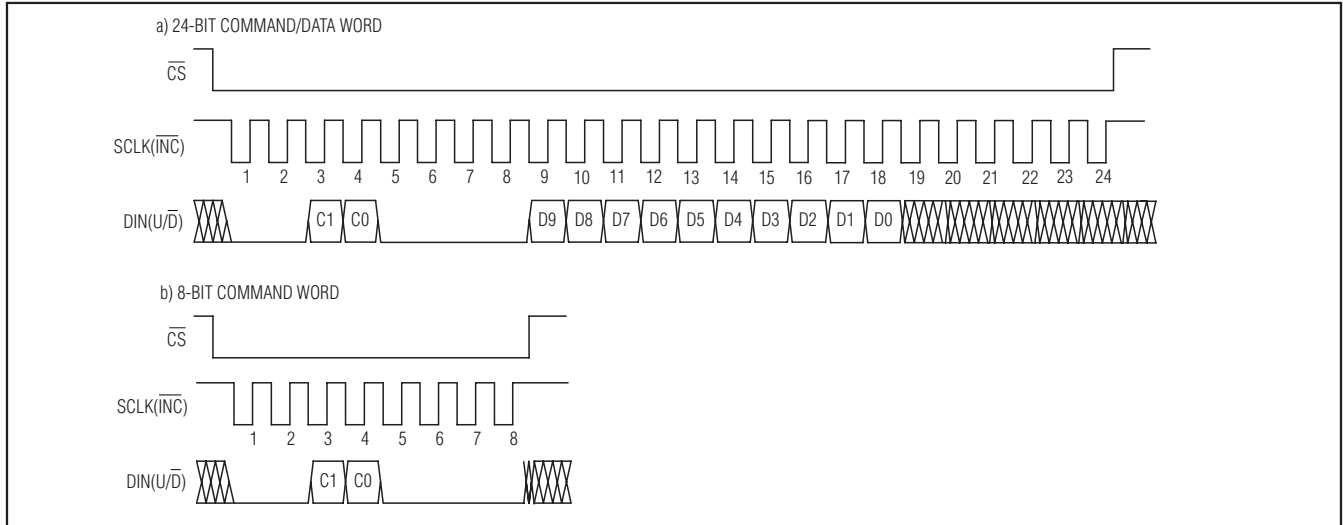

Figure 4. Serial SPI-Compatible Interface Format

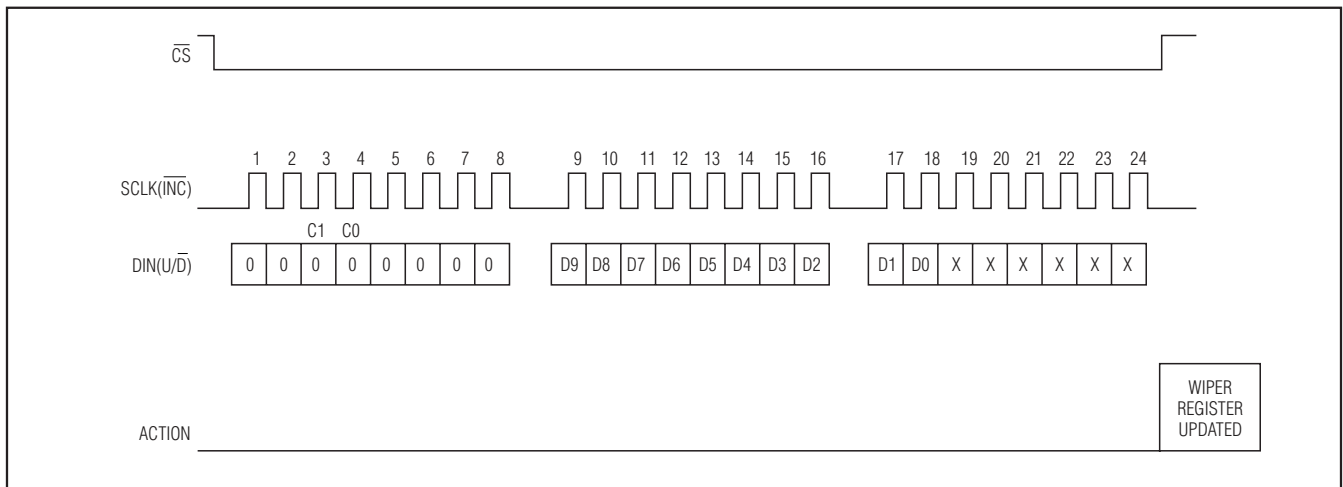

Figure 5. Write Wiper Register Operation

# MAX5481–MAX5484

## 10-Bit, Nonvolatile, Linear-Taper Digital Potentiometers

Table 3. Truth Table

$\overline{\text{CS}}$	DIN(U/D)	SCLK(INC)	W
L	L	↓	Decrement
L	H	↓	Increment
L	X	↑	No Change
H	X	X	No Change
↓	X	X	No Change
↑	X	L	Position Not Stored
↑	X	H	Position Stored

↑ = Low-to-high transition.

↓ = High-to-low transition.

X = Don't care.

### Copy Wiper Register to NV Register

The copy wiper register to NV register command (C1, C0 = 10) stores the current position of the wiper to the NV register for use at power-up. Figure 6 shows how to copy data from wiper register to NV register. The operation takes up to 12ms (max) after  $\overline{\text{CS}}$  goes high to complete and no other operation should be performed until completion.

### Copy NV Register to Wiper Register

The copy NV register to wiper register (C1, C0 = 11) restores the wiper position to the current value stored in the NV register. Figure 7 shows how to copy data from the NV register to the wiper register.

### Digital Up/Down Interface

Figure 8 illustrates an up/down serial-interface timing diagram. In digital up/down interface mode (SPI/UD = 0), the logic inputs  $\overline{\text{CS}}$ , DIN(U/D), and SCLK(INC) control the wiper position and store it in nonvolatile memory (see Table 3). The chip-select ( $\overline{\text{CS}}$ ) input enables the serial interface when low and disables the interface when high. The position of the wiper is stored in the nonvolatile register when  $\overline{\text{CS}}$  transitions from low to high while SCLK(INC) is high.

When the serial interface is active ( $\overline{\text{CS}}$  low), a high-to-low (falling edge) transition on SCLK(INC) increments or decrements the internal 10-bit counter depending on the state of DIN(U/D). If DIN(U/D) is high, the wiper increments. If DIN(U/D) is low, the wiper decrements.

The device stores the value of the wiper position in the nonvolatile memory when  $\overline{\text{CS}}$  transitions from low to high while SCLK(INC) is high. The host system can disable

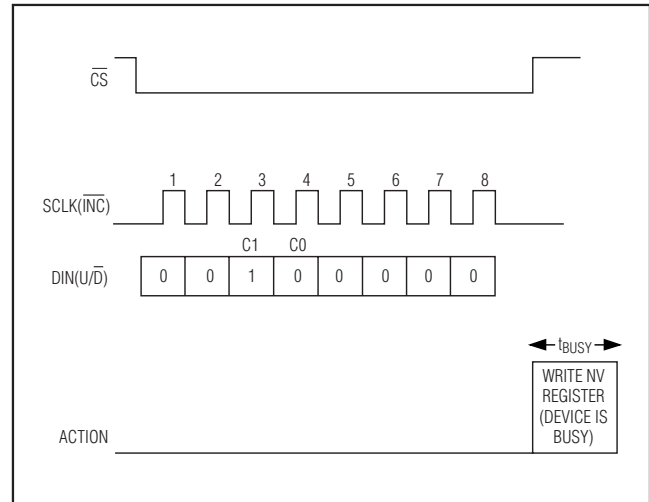

Figure 6. Copy Wiper Register to NV Register Operation

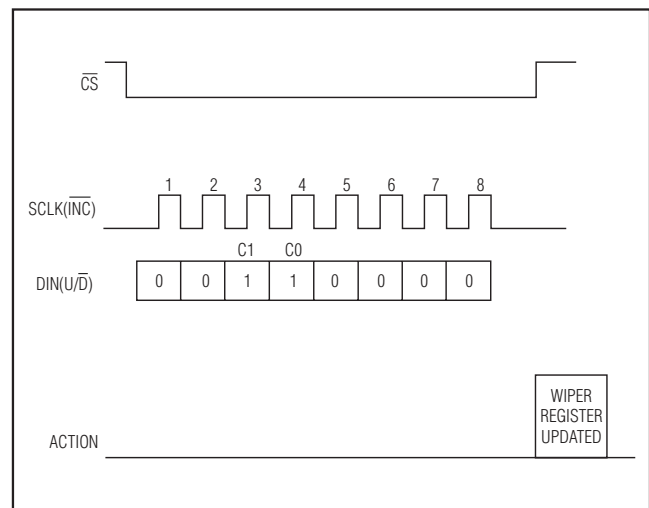

Figure 7. Copy NV Register to Wiper Register Operation

the serial interface and deselect the device without storing the latest wiper position in the nonvolatile memory by keeping SCLK(INC) low while taking  $\overline{\text{CS}}$  high.

Upon power-up, the MAX5481–MAX5484 load the value of nonvolatile memory into the wiper register, and set the wiper position to the value last stored.



# MAX5481–MAX5484

## 10-Bit, Nonvolatile, Linear-Taper Digital Potentiometers

### Standby Mode

The MAX5481–MAX5484 feature a low-power standby mode. When the device is not being programmed, it enters into standby mode and supply current drops to 0.5 $\mu$ A (typ).

### Nonvolatile Memory

The internal EEPROM consists of a nonvolatile register that retains the last value stored prior to power-down. The nonvolatile register is programmed to midscale at the factory. The nonvolatile memory is guaranteed for 50 years of wiper data retention and up to 200,000 wiper write cycles.

### Power-Up

Upon power-up, the MAX5481–MAX5484 load the data stored in the nonvolatile wiper register into the volatile wiper register, updating the wiper position with the data stored in the nonvolatile wiper register.

### Applications Information

The MAX5481–MAX5484 are ideal for circuits requiring digitally controlled adjustable resistance, such as LCD contrast control (where voltage biasing adjusts the display contrast), or programmable filters with adjustable gain and/or cutoff frequency.

### Positive LCD Bias Control

Figures 9 and 10 show an application where a voltage-divider or a variable resistor is used to make an adjustable, positive LCD-bias voltage. The op amp provides buffering and gain to the voltage-divider network made by the programmable voltage-divider (Figure 9) or to a fixed resistor and a variable resistor (see Figure 10).

### Programmable Gain and Offset Adjustment

Figure 11 shows an application where a voltage-divider and a variable resistor are used to make a programmable gain and offset adjustment.

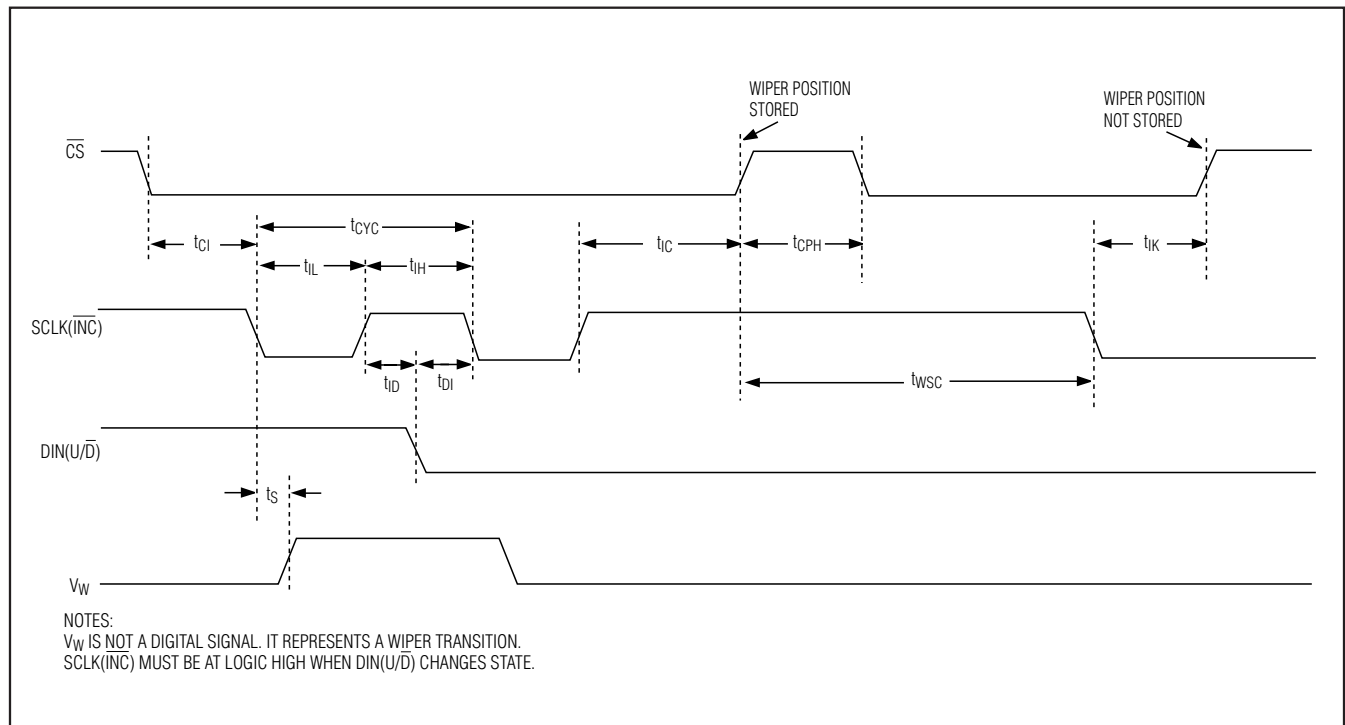

Figure 8. Up/Down Serial-Interface Timing Diagram ( $SPI/\overline{UD} = 0$ )

# MAX5481-MAX5484

## 10-Bit, Nonvolatile, Linear-Taper Digital Potentiometers

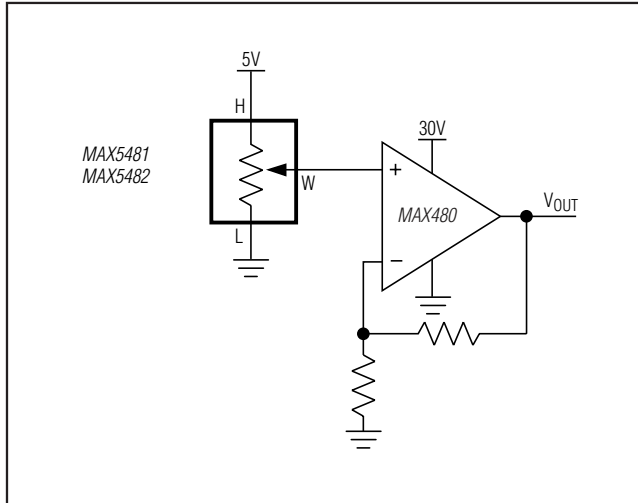

Figure 9. Positive LCD Bias Control Using a Voltage-Divider

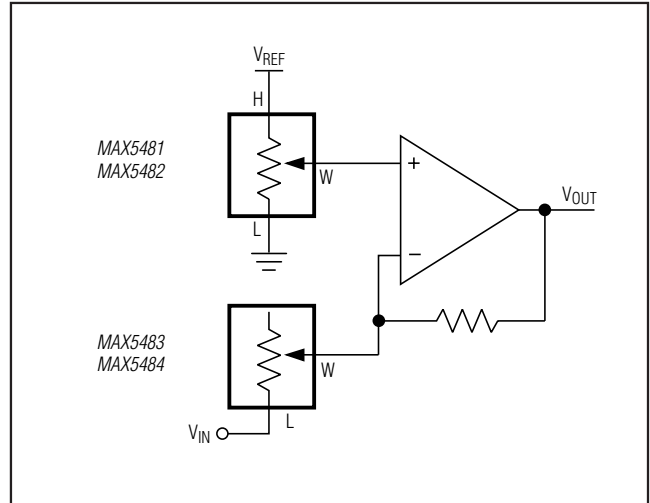

Figure 11. Programmable Gain/Offset Adjustment

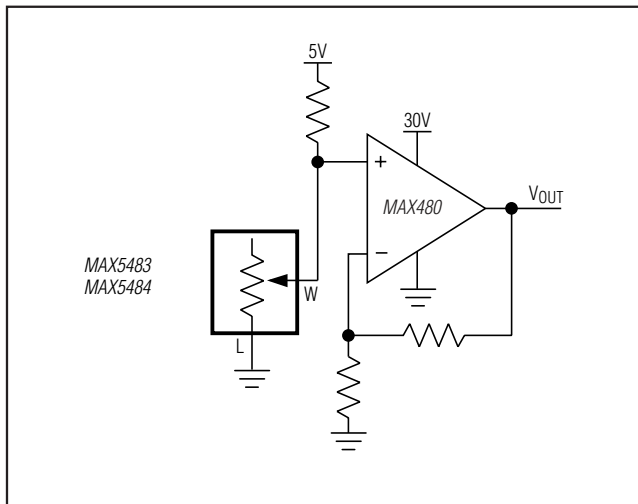

Figure 10. Positive LCD Bias Control Using a Variable Resistor

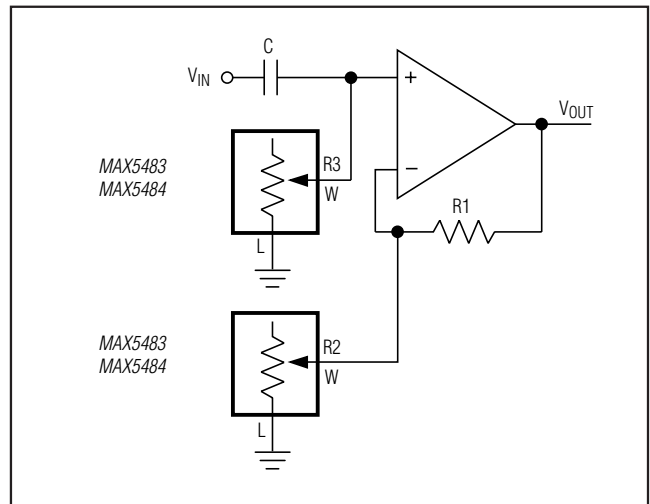

Figure 12. Programmable Filter

### Programmable Filter

Figure 12 shows the configuration for a 1st-order programmable filter using two variable resistors. Adjust R2 for the gain and adjust R3 for the cutoff frequency. Use the following equations to estimate the gain (G) and the 3dB cutoff frequency ( $f_c$ ):

$$G = 1 + \left( \frac{R1}{R2} \right)$$

$$f_c = \frac{1}{2\pi \times R3 \times C}$$

# MAX5481-MAX5484

## 10-Bit, Nonvolatile, Linear-Taper Digital Potentiometers

### Selector Guide

PART	CONFIGURATION	END-TO-END RESISTANCE (kΩ)
MAX5481ETE	Voltage-divider	10
MAX5481EUD	Voltage-divider	10
MAX5482ETE	Voltage-divider	50
MAX5482EUD	Voltage-divider	50
MAX5483ETE	Variable resistor	10
MAX5483EUD	Variable resistor	10
MAX5484ETE	Variable resistor	50
MAX5484EUD	Variable resistor	50

### Ordering Information (continued)

PART	PIN-PACKAGE	TOP MARK
MAX5482ETE+	16 TQFN-EP*	ACQ
MAX5482EUD+	14 TSSOP	—
MAX5483ETE+	16 TQFN-EP*	ACR
MAX5483EUD+	14 TSSOP	—
MAX5484ETE+	16 TQFN-EP*	ACS
MAX5484EUD+	14 TSSOP	—

**Note:** All devices are specified over the -40°C to +85°C operating temperature range.

+ Denotes a lead(Pb)-free/RoHS-compliant package.

\*EP = Exposed pad.

### Pin Configurations (continued)

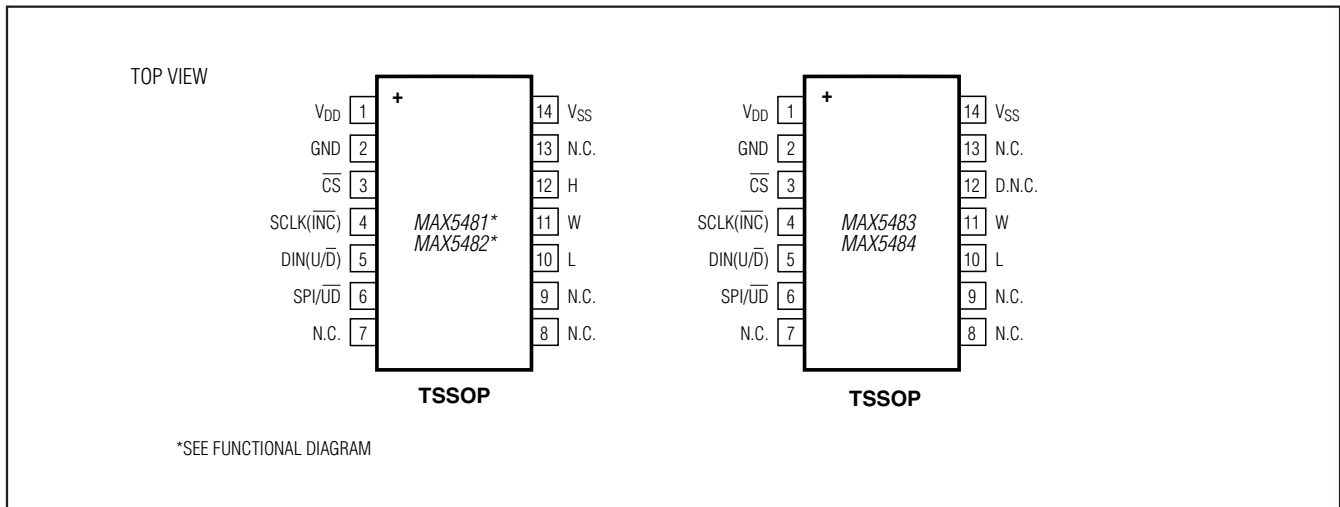

### Chip Information

PROCESS: BiCMOS

### Package Information

For the latest package outline information and land patterns, go to [www.maxim-ic.com/packages](http://www.maxim-ic.com/packages). Note that a "+", "#", or "-" in the package code indicates RoHS status only. Package drawings may show a different suffix character, but the drawing pertains to the package regardless of RoHS status.

PACKAGE TYPE	PACKAGE CODE	OUTLINE NO.	LAND PATTERN NO.
16 TQFN-EP	T1633F+3	<a href="#">21-0136</a>	<a href="#">90-0033</a>
14 TSSOP	U14+1	<a href="#">21-0066</a>	<a href="#">90-0113</a>

# MAX5481–MAX5484

## 10-Bit, Nonvolatile, Linear-Taper Digital Potentiometers

### Revision History

REVISION NUMBER	REVISION DATE	DESCRIPTION	PAGES CHANGED
3	12/07	Updated Table 3	16
4	4/10	Updated <i>Ordering Information</i> , <i>Absolute Maximum Ratings</i> , and Figure 8	1, 2, 17



Maxim cannot assume responsibility for use of any circuitry other than circuitry entirely embodied in a Maxim product. No circuit patent licenses are implied. Maxim reserves the right to change the circuitry and specifications without notice at any time. The parametric values (min and max limits) shown in the Electrical Characteristics table are guaranteed. Other parametric values quoted in this data sheet are provided for guidance.

Компания «Океан Электроники» предлагает заключение долгосрочных отношений при поставках импортных электронных компонентов на взаимовыгодных условиях!

Наши преимущества:

- Поставка оригинальных импортных электронных компонентов напрямую с производств Америки, Европы и Азии, а так же с крупнейших складов мира;
- Широкая линейка поставок активных и пассивных импортных электронных компонентов (более 30 млн. наименований);
- Поставка сложных, дефицитных, либо снятых с производства позиций;
- Оперативные сроки поставки под заказ (от 5 рабочих дней);
- Экспресс доставка в любую точку России;
- Помощь Конструкторского Отдела и консультации квалифицированных инженеров;
- Техническая поддержка проекта, помощь в подборе аналогов, поставка прототипов;
- Поставка электронных компонентов под контролем ВП;
- Система менеджмента качества сертифицирована по Международному стандарту ISO 9001;
- При необходимости вся продукция военного и аэрокосмического назначения проходит испытания и сертификацию в лаборатории (по согласованию с заказчиком);
- Поставка специализированных компонентов военного и аэрокосмического уровня качества (Xilinx, Altera, Analog Devices, Intersil, Interpoint, Microsemi, Actel, Aeroflex, Peregrine, VPT, Syfer, Eurofarad, Texas Instruments, MS Kennedy, Miteq, Cobham, E2V, MA-COM, Hittite, Mini-Circuits, General Dynamics и др.);

Компания «Океан Электроники» является официальным дистрибьютором и эксклюзивным представителем в России одного из крупнейших производителей разъемов военного и аэрокосмического назначения «JONHON», а так же официальным дистрибьютором и эксклюзивным представителем в России производителя высокотехнологичных и надежных решений для передачи СВЧ сигналов «FORSTAR».



## JONHON

«JONHON» (основан в 1970 г.)

Разъемы специального, военного и аэрокосмического назначения:

(Применяются в военной, авиационной, аэрокосмической, морской, железнодорожной, горно- и нефтедобывающей отраслях промышленности)

«FORSTAR» (основан в 1998 г.)

ВЧ соединители, коаксиальные кабели,  
кабельные сборки и микроволновые компоненты:

(Применяются в телекоммуникациях гражданского и специального назначения, в средствах связи, РЛС, а так же военной, авиационной и аэрокосмической отраслях промышленности).



Телефон: 8 (812) 309-75-97 (многоканальный)

Факс: 8 (812) 320-03-32

Электронная почта: [ocean@oceanchips.ru](mailto:ocean@oceanchips.ru)

Web: <http://oceanchips.ru/>

Адрес: 198099, г. Санкт-Петербург, ул. Калинина, д. 2, корп. 4, лит. А