

# QUICK START GUIDE FOR DEMONSTRATION CIRCUIT 616

## 4MHZ, POLYPHASE HIGH EFFICIENCY SYNCHRONOUS BOOST CONVERTER

### LTC3425EUH

## DESCRIPTION

Demonstration Circuit 616 is a synchronous, 4-phase boost converter using the LTC3425. It is capable of operating below 1V input. DC616A is set for 3.3V output. DC616B is set for 5V output. On each demo board, the left circuit gives higher efficiency and current rating; while the right circuit has smaller size and lower cost.

The switching frequency is set at 1MHz per phase, minimizing inductor and capacitor size. A single resistor at RT pin sets the frequency. If desired, the LTC3425 can be synchronized to an external clock.

Long wires run from input sources (such as wall adaptors) can cause large voltage spikes during initial plug-in. C5 and C15 are installed on DC616 to damp the possible voltage spikes. They are not required for applications where input source is close to the regulator. Please refer to Application Note 88 for details.

**Design files for this circuit board are available. Call the LTC factory.**

**Table 1. DC616A Performance Summary ( $T_A = 25^\circ\text{C}$  unless otherwise noted)**

PARAMETER	CONDITION	VALUE
Minimum Input Voltage (Start-Up)		1V
Output Voltage $V_{OUT1}$ (High Efficiency Circuit)	$V_{IN} = 2V$ to $3V$ , $I_{OUT1} = 0A$ to $2.25A$	$3.3V \pm 4\%$
Output Voltage $V_{OUT2}$ (Low Cost Circuit)	$V_{IN} = 2V$ to $3V$ , $I_{OUT2} = 0A$ to $1.8A$	$3.3V \pm 4\%$
Maximum Output Current (High Efficiency Circuit)	$V_{IN} = 2V$ to $3V$	$2.25A$
Maximum Output Current (Low Cost Circuit)	$V_{IN} = 2V$ to $3V$	$1.8A$
Typical Output Ripple $V_{OUT}$	$V_{IN} = 2.4V$ , $I_{OUT} = 1.8A$ (20MHz BW)	$28mV_{p-p}$
Typical Switching Frequency (each phase)		1MHz
Efficiency (High Efficiency Circuit)	$V_{IN} = 2.4V$ , $I_{OUT1} = 0.5A$	93.0% Typical
	$V_{IN} = 2.4V$ , $I_{OUT1} = 2A$	88.6% Typical
On/Off Control	Logic Low Voltage-Off, $-40^\circ\text{C}$ to $85^\circ\text{C}$	0.25V MAX
	Logic High Voltage-On (Initial Start-Up), $-40^\circ\text{C}$ to $85^\circ\text{C}$	1V MIN
	Logic High Voltage-On ( $V_{OUT} > 2.4V$ ), $-40^\circ\text{C}$ to $85^\circ\text{C}$	0.65V MIN

# QUICK START GUIDE FOR DEMONSTRATION CIRCUIT 616

## 4MHZ, POLYPHASE HIGH EFFICIENCY SYNCHRONOUS BOOST CONVERTER

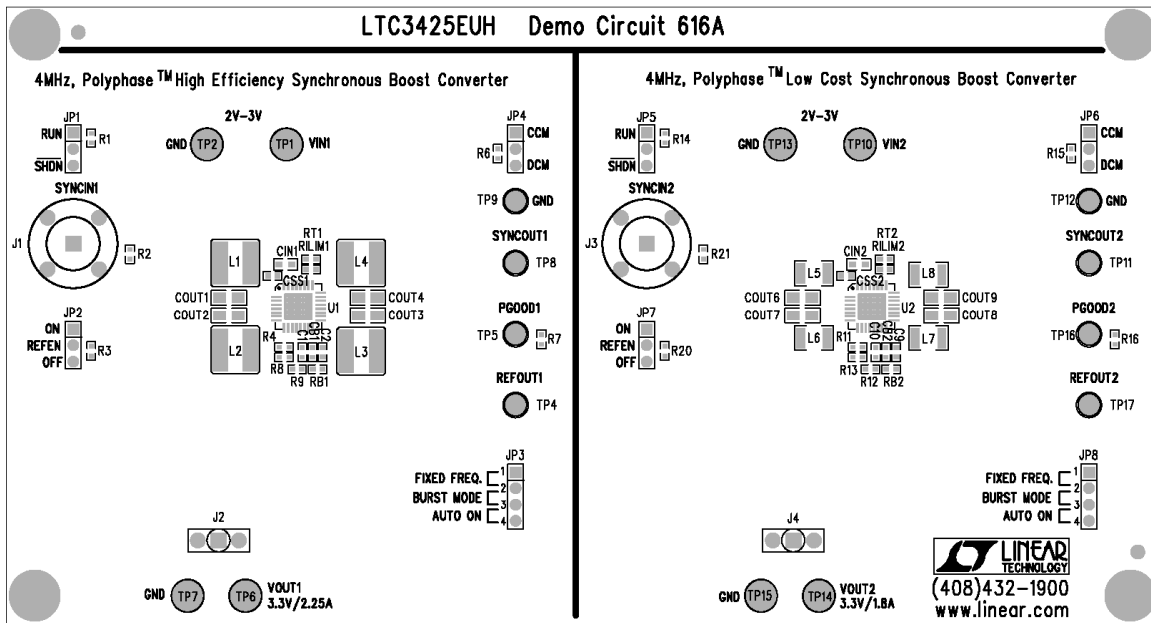

**Demo Circuit 616A = 3.3Vout@2.25A or 1.8A**

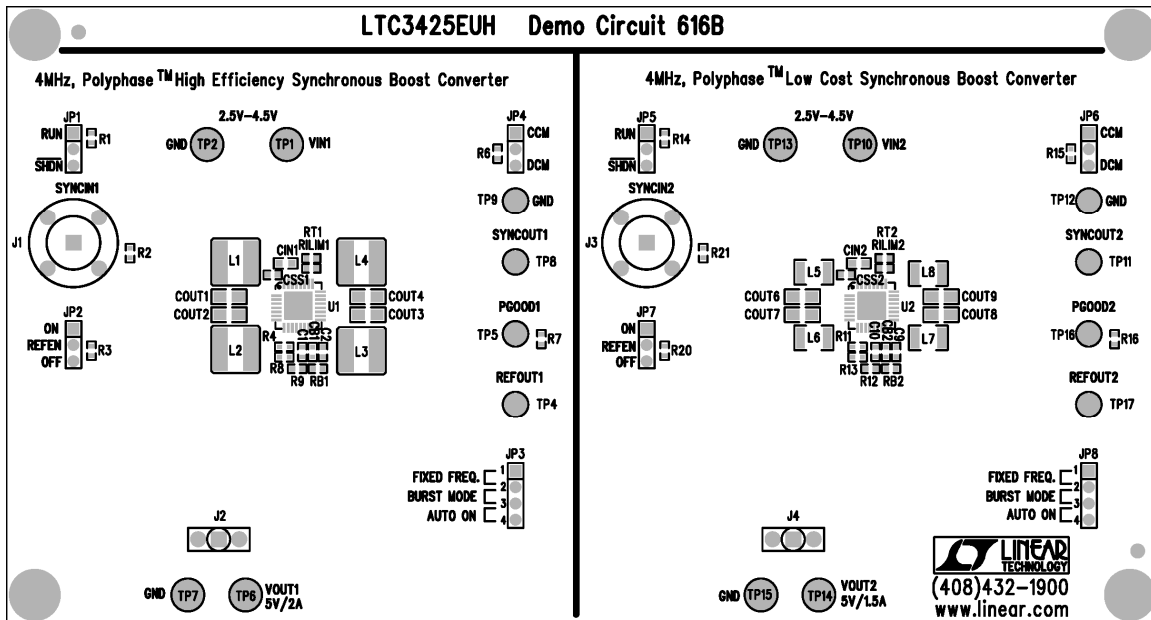

**Demo Circuit 616B = 5Vout@2.0A or 1.5A**

# QUICK START GUIDE FOR DEMONSTRATION CIRCUIT 616

## 4MHZ, POLYPHASE HIGH EFFICIENCY SYNCHRONOUS BOOST CONVERTER

**Table 2. DC616B Performance Summary ( $T_A = 25^\circ\text{C}$  unless otherwise noted)**

PARAMETER	CONDITION	VALUE
Minimum Input Voltage (Start-Up)		1V
Output Voltage $V_{OUT1}$ (High Efficiency Circuit)	$V_{IN} = 2.5\text{V to } 4.5\text{V}$ , $I_{OUT1} = 0\text{A to } 2\text{A}$	$5\text{V} \pm 4\%$
Output Voltage $V_{OUT2}$ (Low Cost Circuit)	$V_{IN} = 2.5\text{V to } 4.5\text{V}$ , $I_{OUT2} = 0\text{A to } 1.5\text{A}$	$5\text{V} \pm 4\%$
Maximum Output Current (High Efficiency Circuit)	$V_{IN} = 2.5\text{V to } 4.5\text{V}$	2A
Maximum Output Current (Low Cost Circuit)	$V_{IN} = 2.5\text{V to } 4.5\text{V}$	1.5A
Typical Output Ripple $V_{OUT}$	$V_{IN} = 3.3\text{V}$ , $I_{OUT} = 1.5\text{A}$ (20MHz BW)	33mV <sub>P-P</sub>
Typical Switching Frequency (each phase)		1MHz
Efficiency (High Efficiency Circuit)	$V_{IN} = 3.3\text{V}$ , $I_{OUT1} = 0.5\text{A}$	93.0% Typical
	$V_{IN} = 3.3\text{V}$ , $I_{OUT1} = 2\text{A}$	92.3% Typical
On/Off Control	Logic Low Voltage-Off, $-40^\circ\text{C to } 85^\circ\text{C}$	0.25V MAX
	Logic High Voltage-On (Initial Start-Up), $-40^\circ\text{C to } 85^\circ\text{C}$	1V MIN
	Logic High Voltage-On ( $V_{OUT} > 2.4\text{V}$ ), $-40^\circ\text{C to } 85^\circ\text{C}$	0.65V MIN

## QUICK START PROCEDURE

Demonstration circuit 616 is easy to set up to evaluate the performance of the LTC3425. Refer to Figure 1 for proper measurement equipment setup and follow the procedure below:

**NOTE:** When measuring the input or output voltage ripple, care must be taken to avoid a long ground lead on the oscilloscope probe. Measure the input or output voltage ripple by touching the probe tip directly across the  $V_{in}$  or  $V_{out}$  and GND terminals. See Figure 2 for proper scope probe technique.

1. Place jumpers in the following positions:

**JP1, JP5**    RUN  
**JP2, JP7**    ON  
**JP4, JP6**    DCM  
**JP3, JP8**    AUTO ON.

2. With power off, connect the input power supply to  $V_{IN1}$  and GND or  $V_{IN2}$  and GND.
3. Turn on the power at the input.

**NOTE:** Make sure that the input voltage does not exceed 4.5V.

4. Check for the proper output voltage.
5. If there is no output, temporarily disconnect the load to make sure that the load is not set too high.

# QUICK START GUIDE FOR DEMONSTRATION CIRCUIT 616

## 4MHZ, POLYPHASE HIGH EFFICIENCY SYNCHRONOUS BOOST CONVERTER

- Once the proper output voltage is established, adjust the load within the operating range and observe the output voltage regulation, ripple voltage, efficiency and other parameters.
- Different operating modes can be selected according to the following table:

**Table 3. LTC3425 Operating Modes**

OPERATING MODE	JP3, JP8 POSITION	JP4, JP6 POSITION
Forced Burst	BURST MODE	DCM
Automatic Burst (Operating Mode is Load Dependent)	AUTO ON	DCM
Forced Fixed Frequency with Pulse Skipping at light load	FIXED FREQ	DCM
Forced Fixed Frequency, Low Noise (No Pulse Skipping)	FIXED FREQ	CCM

- The active clamping circuits are installed on DC616B to prevent the voltages at switch nodes from exceeding the maximum rating (refer to data sheet "Applications Where  $V_{OUT} > 4.3V$ " section for details). If there is any momentary short-circuit condition, please add a  $10\Omega$  in series with Q1.

### GRAPHIC

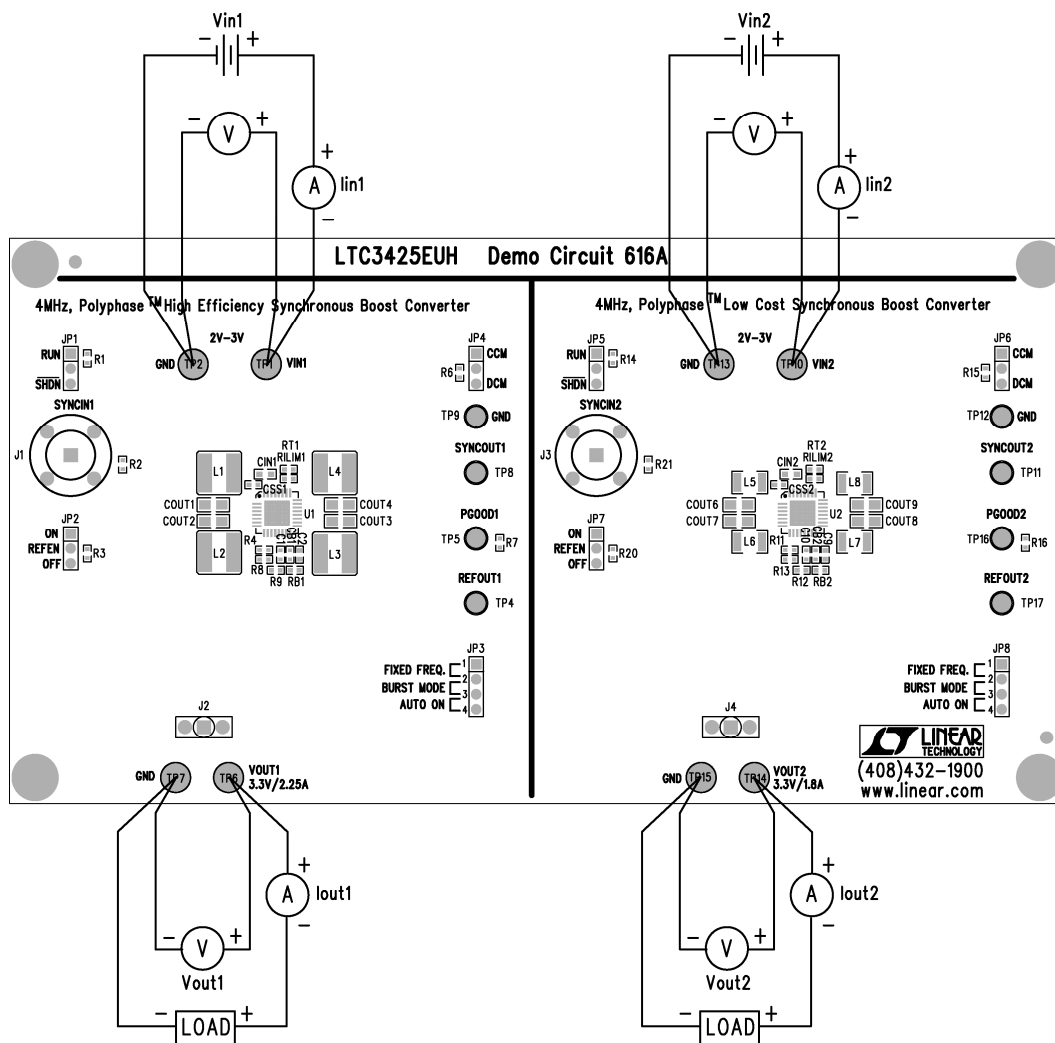

**Figure 1. Proper Measurement Equipment Setup**

# QUICK START GUIDE FOR DEMONSTRATION CIRCUIT 616

## 4MHZ, POLYPHASE HIGH EFFICIENCY SYNCHRONOUS BOOST CONVERTER

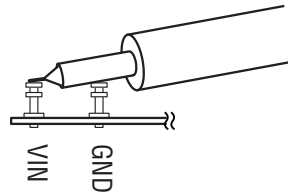

Figure 2. Measuring Input or Output Ripple

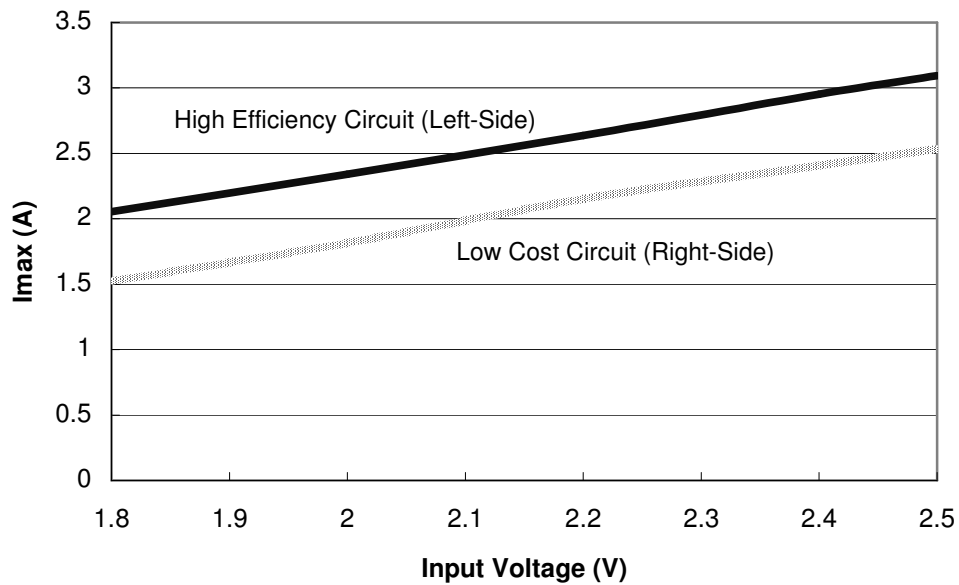

Figure 3. Maximum Output Current vs Input Voltage for 3.3V Output (DC616A)

# QUICK START GUIDE FOR DEMONSTRATION CIRCUIT 616

## 4MHZ, POLYPHASE HIGH EFFICIENCY SYNCHRONOUS BOOST CONVERTER

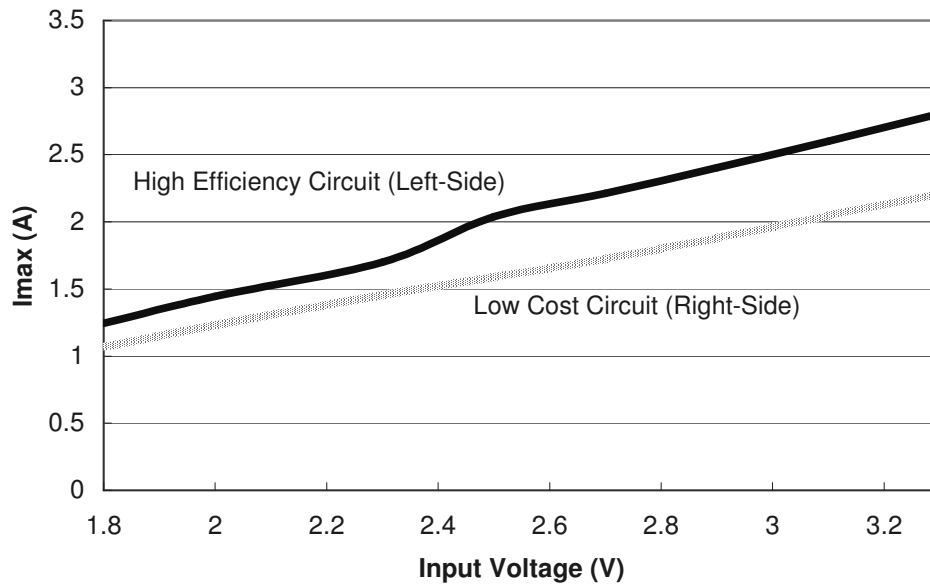

Figure 4. Maximum Output Current vs Input Voltage for 5V Output (DC616B)

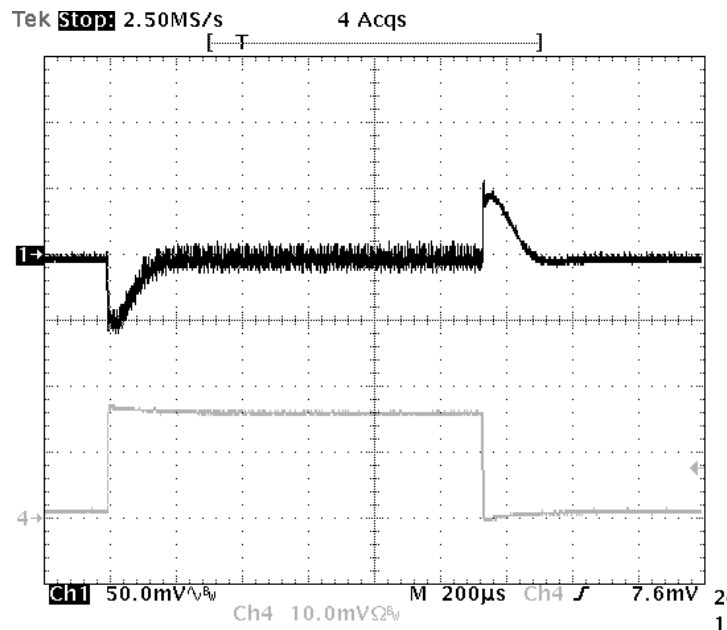

Figure 5. DC616A Load Transient Response ( $V_{in}=2.4V$ ; Channel 1:  $V_{out1}$ ; Channel 2:  $I_{out}$ : load step from 0.2A to 2.25A)

# QUICK START GUIDE FOR DEMONSTRATION CIRCUIT 616

## 4MHZ, POLYPHASE HIGH EFFICIENCY SYNCHRONOUS BOOST CONVERTER

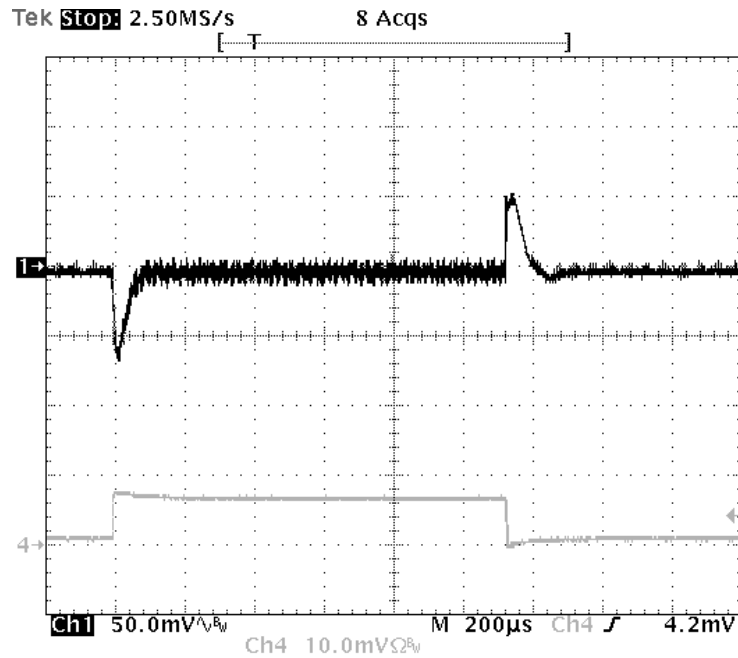
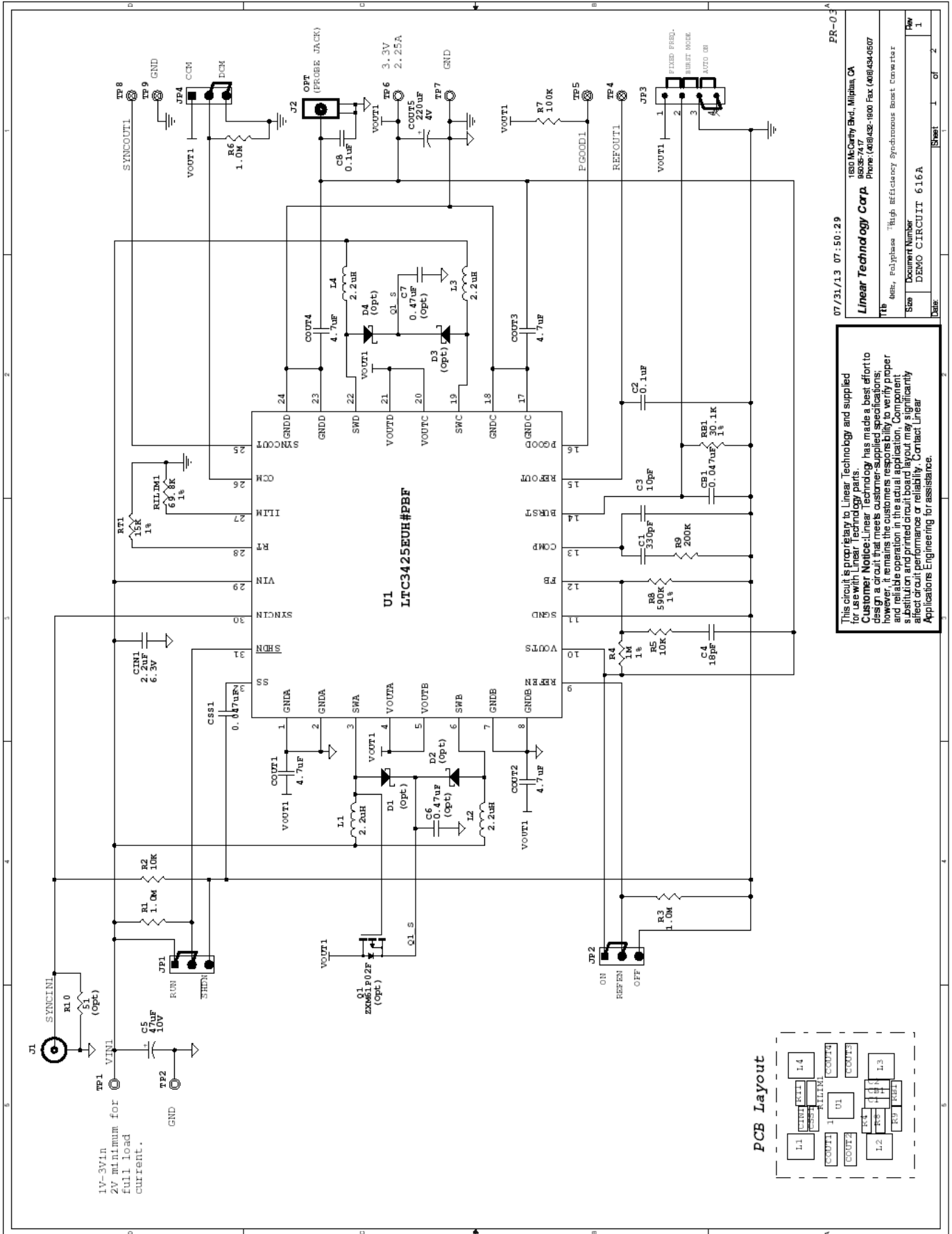

Figure 6. DC616B Load Transient Response (Vin=4.2V;Channel 1: Vout1; Channel 2: Iout1: load step from 0.2A to 2A)

# QUICK START GUIDE FOR DEMONSTRATION CIRCUIT 616

## 4MHZ, POLYPHASE HIGH EFFICIENCY SYNCHRONOUS BOOST CONVERTER



This circuit is proprietary to Linear Technology and supplied for Customer Notice-Linear Technology has made a best effort to design a circuit that meets customer-supplier specifications; however, it remains the customer's responsibility to verify proper and reliable operation in the actual application. Component substitution and printed circuit board layout may significantly affect circuit performance or reliability. Contact Linear Applications Engineering for assistance.



# QUICK START GUIDE FOR DEMONSTRATION CIRCUIT 616

## 4MHZ, POLYPHASE HIGH EFFICIENCY SYNCHRONOUS BOOST CONVERTER

**V<sub>in</sub>=1V to 3V**

**V<sub>out</sub>=3.3V@2.25A**

Item	Qty	Ref - Des	Part Description	Manufacturer's Part Number
1	2	CB1,CSS1	Cap., X5R 0.047uF 16V 20%	AVX 0402YD473MAT2A
2	1	CIN1	Cap., X5R 2.2uF 6.3V 10%	TAIYO YUDEN JMK107BJ225KA-T
3	4	COU1,COU2,COU3,COU4	Cap., X5R 4.7uF 6.3V 20%	TAIYO YUDEN JMK212ABJ475MG-T
4	1	COU5	Cap, SP-CAP 220uF 4V .009 ohm, case size D2	PANASONIC EEF5X0G221ER
5	1	C1	Cap., NPO 330pF 25V 10%	AVX 04023A331KAT2A
6	2	C2,C8	Cap., X5R 0.1uF 10V 10%	TDK C1005X5R1A104K
7	1	C3	Cap., NPO 10pF 25V 10%	AVX 04023A100KAT2A
8	1	C4	Cap., NPO 18pF 25V 10%	AVX 04023A180KAT2A
9	1	C5	Cap., Tant. 47uF 10V 20%	AVX TAJB476M010RNJ
10	0	C6,C7 (Opt)	Cap., X5R 0.47uF 10V 10%	Taiyo Yuden LMK107BJ474KA-T
11	0	D1,D2,D3,D4 (Opt)	Schottky Diode, UPS5817	Microsemi UPS5817
12	3	JP1,JP2,JP4	Headers, 3 Pins 2mm Ctrs.	SULLINS NRPN031PAEN-RC
13	1	JP3	Headers, Commcon2802s04g2	SULLINS NRPN041PAEN-RC
14	1	J1	BNC Connector	Connex 112404
15	0	J2 (Opt)	Test Jacks, Shielded	Johnson Components 129-0701-201
16	4	L1,L2,L3,L4	Inductor, 2.2uH	COILCRAFT XAL5030-222MEC
17	0	Q1 (Opt)	P-Channel, 20V	ZETEX ZXM61P02F
18	1	RB1	Res., Chip 30.1K 0.06W 1%	VISHAY CRCW040230K1FKED
19	1	RILIM1	Res., Chip 69.8K 0.06W 1%	VISHAY CRCW040269K8FKED
20	1	RT1	Res., Chip 15K 0.06W 1%	VISHAY CRCW040215K0FKED
21	3	R1,R3,R6	Res., Chip 1.0M 1/16W 5%	VISHAY CRCW04021M00JNED
22	2	R5,R2	Res., Chip 10K 0.06W 5%	VISHAY CRCW040210K0JNED
23	1	R4	Res., Chip 1M 1/16W 1%	VISHAY CRCW04021M00FKED
24	1	R7	Res., Chip 100K 0.06W 5%	VISHAY CRCW0402100KJNED
25	1	R8	Res., Chip 590K 0.06W 1%	VISHAY CRCW0402590KFKED
26	1	R9	Res., Chip 200K 0.06W 5%	VISHAY CRCW0402200KJNED
27	0	R10 (Opt)	Res., Chip 51 0.06W 5%	VISHAY CRCW040251R0JNED
28	4	TP1,TP2,TP6,TP7	Turret, Testpoint	MILL-MAX 2501-2-00-80-00-00-07-0
29	4	TP4,TP5,TP8,TP9	Turret, Testpoint	MILL-MAX 2308-2-00-80-00-00-07-0
30	1	U1	I.C., Polyphase Switching Reg.	LINEAR TECH. CORP. LTC3425EUH#PBF

# QUICK START GUIDE FOR DEMONSTRATION CIRCUIT 616

## 4MHZ, POLYPHASE HIGH EFFICIENCY SYNCHRONOUS BOOST CONVERTER

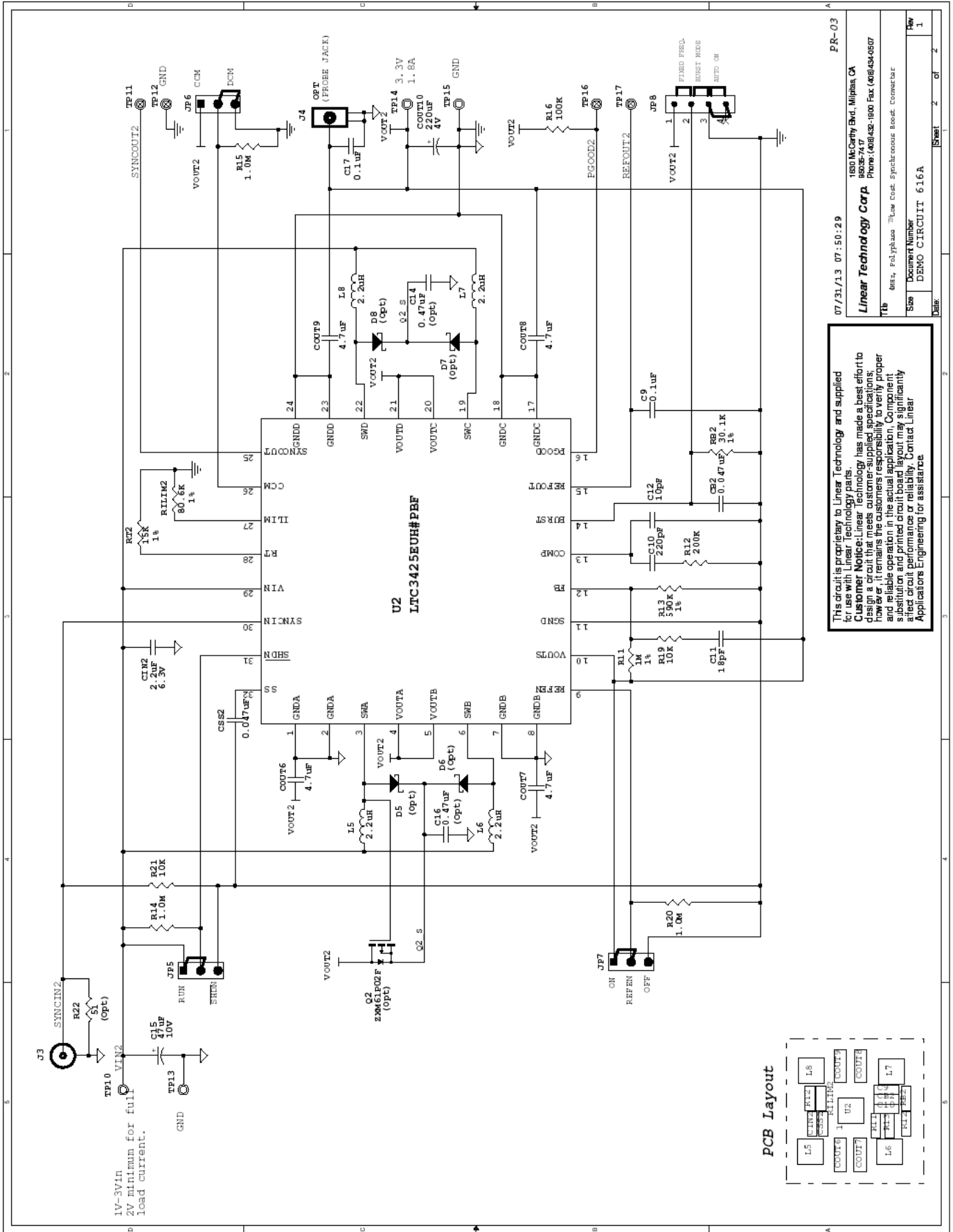

This circuit is proprietary to Linear Technology and supplied for use with Linear Technology parts.  
Customer Notice: Linear Technology has made a best effort to design a circuit that meets customer-supplied specifications; however, it remains the customer's responsibility to verify proper and reliable operation in the actual application. Component substitution and printed circuit board layout may significantly affect circuit performance. Contact Linear Applications Engineering for assistance.

### PCB Layout



07/31/13 07:50:29 PR-03

1800 McCarty Blvd, Milpitas, CA  
95052-7417  
Linear Technology Corp. Phone: (408)432-1000 Fax: (408)434-0507

Rev	1
Docu	1
Sheet	2 of 2
Date	
Docu	1
Sheet	2 of 2
Date	

# QUICK START GUIDE FOR DEMONSTRATION CIRCUIT 616

## 4MHZ, POLYPHASE HIGH EFFICIENCY SYNCHRONOUS BOOST CONVERTER

**V<sub>in</sub>=1V to 3V**

**V<sub>out</sub>=3.3V@1.8A**

Item	Qty	Ref - Des	Part Description	Manufacturer's Part Number
1	2	CSS2,CB2	Cap., X5R 0.047uF 16V 20%	AVX 0402YD473MAT2A
2	1	CIN2	Cap., X5R 2.2uF 6.3V 10%	Taiyo Yuden JMK107BJ225KA-T
3	4	COU6,COU7,COU8,COU9	Cap., X5R 4.7uF 6.3V 20%	TAIYO YUDEN JMK212ABJ475MG-T
4	1	COU10	Cap, SP-CAP 220uF 4V .009 ohm, case size D2	PANASONIC EEFSX0G221ER
5	2	C17,C9	Cap., X5R 0.1uF 10V 10%	TDK C1005X5R1A104K
6	1	C10	Cap., NPO 220pF 25V 10%	AVX 04023A221KAT2A
7	1	C11	Cap., NPO 18pF 25V 10%	AVX 04023A180KAT2A
8	1	C12	Cap., NPO 10pF 25V 10%	AVX 04023A100KAT2A
9	0	C16,C14 (Opt)	Cap., X5R 0.47uF 10V 10%	Taiyo Yuden LMK107BJ474KA-T
10	1	C15	Cap., Tant. 47uF 10V 20%	AVX TAJB476M010RNJ
11	4	D5,D6,D7,D8 (Opt)	Schottky Diode, UPS5817	Microsemi UPS5817
12	3	JP5,JP6,JP7	Headers, 3 Pins 2mm Ctrs.	SULLINS NRPN031PAEN-RC
13	1	JP8	Headers, Common2802s04g2	SULLINS NRPN041PAEN-RC
14	1	J3	BNC Connector	Connex 112404
15	0	J4 (Opt)	Test Jacks, Shielded	Johnson Components 129-0701-201
16	4	L5,L6,L7,L8	Inductor, 2.2uH	muRata LQH32CN2R2M53
17	0	Q2 (Opt)	P-Channel, 20V	ZETEX ZXM61P02F
18	1	RB2	Res., Chip 30.1K 0.06W 1%	VISHAY CRCW040230K1FKED
19	1	RILIM2	Res., Chip 80.6K 0.06W 1%	VISHAY CRCW040269K8FKED
20	1	RT2	Res., Chip 15K 0.06W 1%	VISHAY CRCW040215K0FKED
21	1	R11	Res., Chip 1M 1/16W 1%	VISHAY CRCW04021M00FKED
22	1	R12	Res., Chip 200K 0.06W 5%	VISHAY CRCW0402200KJNED
23	1	R13	Res., Chip 590K 0.06W 1%	VISHAY CRCW0402590KFKED
24	3	R14,R15,R20	Res., Chip 1.0M 1/16W 5%	VISHAY CRCW04021M00JNED
25	1	R16	Res., Chip 100K 0.06W 5%	VISHAY CRCW0402100KJNED
26	2	R21,R19	Res., Chip 10K 0.06W 5%	VISHAY CRCW040210K0JNED
27	0	R22 (Opt)	Res., Chip 51 0.06W 5%	VISHAY CRCW040251R0JNED
28	4	TP10,TP13,TP14,TP15	Turret, Testpoint	MILL-MAX 2501-2-00-80-00-00-07-0
29	4	TP11,TP12,TP16,TP17	Turret, Testpoint	MILL-MAX 2308-2-00-80-00-00-07-0
30	1	U2	I.C., Polyphase Switching Reg.	LINEAR TECH. CORP. LTC3425EUH#PBF

# QUICK START GUIDE FOR DEMONSTRATION CIRCUIT 616 4MHZ, POLYPHASE HIGH EFFICIENCY SYNCHRONOUS BOOST CONVERTER

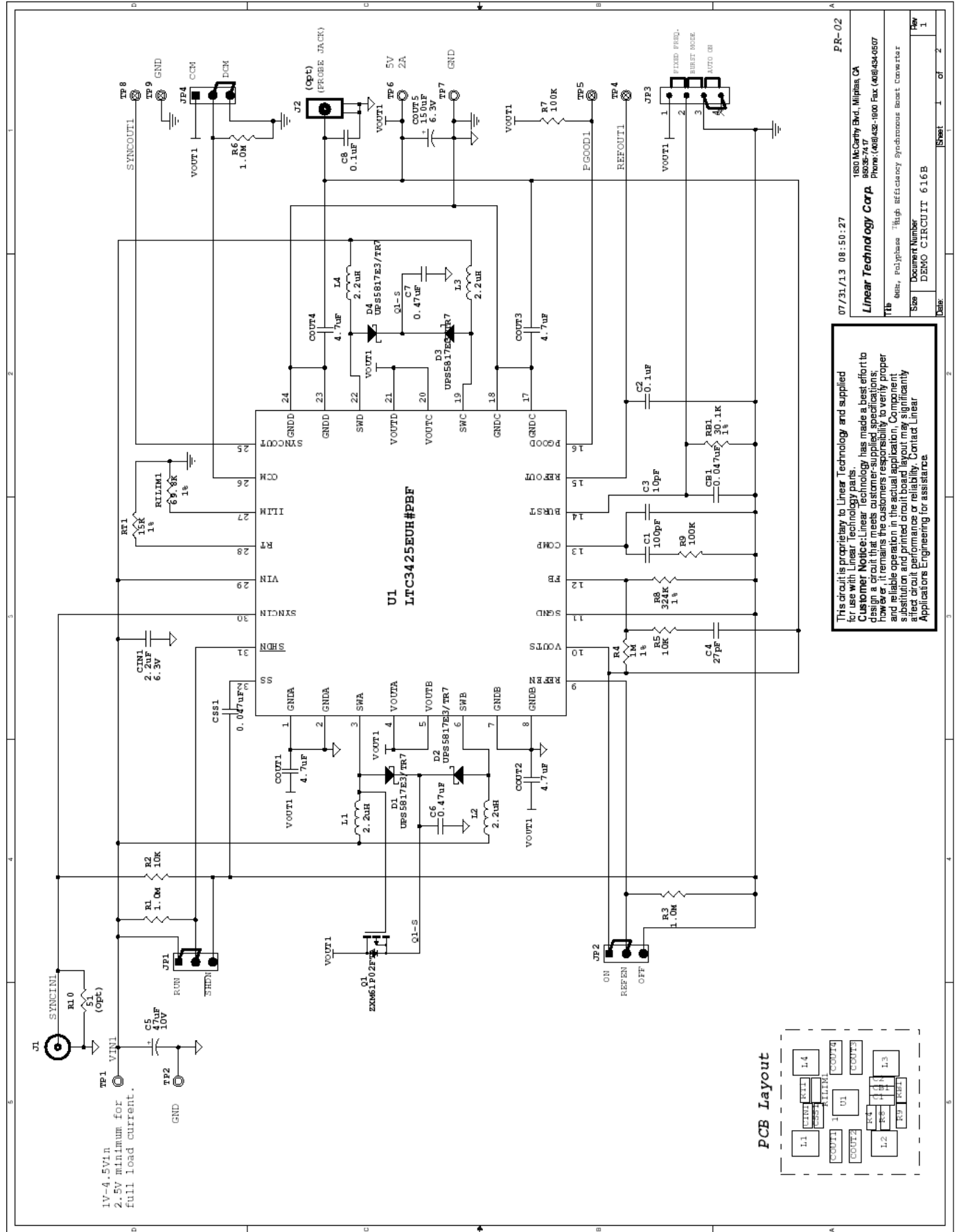

07/31/13 08:50:27 PR-02  
**Linear Technology Corp.**  
 180 McCarthy Blvd., Milpitas, CA 95052-7417  
 Phone: (408)432-1000 Fax: (408)434-0507  
 www.linear.com  
 Title: Demo Circuit Number: DEMO CIRCUIT 616B  
 Rev: 1  
 Date:

# QUICK START GUIDE FOR DEMONSTRATION CIRCUIT 616

## 4MHZ, POLYPHASE HIGH EFFICIENCY SYNCHRONOUS BOOST CONVERTER

**V<sub>in</sub>=2.5V to 4.5V**

**V<sub>out</sub>=5V@2A**

Item	Qty	Ref - Des	Part Description	Manufacture's Part Number
1	2	CB1,CSS1	Cap., X5R 0.047uF 16V 20%	AVX 0402YD473MAT2A
2	1	CIN1	Cap., X5R 2.2uF 6.3V 10%	Taiyo Yuden JMK107BJ225KA-T
3	4	COU11,COU2,COU3,COU4	Cap., X5R 4.7uF 6.3V 20%	TAIYO YUDEN JMK212ABJ475MG-T
4	1	COU5	Cap., POSCAP 150uF 6.3V 20%	PANASONIC 6TPE150M
5	1	C1	Cap., NPO 100pF 25V 10%	AVX 04023A101KAT2A
6	2	C8,C2	Cap., X5R 0.1uF 10V 10%	TDK C1005X5R1A104K
7	1	C3	Cap., NPO 10pF 25V 10%	AVX 04023A100KAT2A
8	1	C4	Cap., NPO 27pF 25V 10%	AVX 04023A270KAT2A
9	1	C5	Cap., Tant. 47uF 10V 20%	AVX TAJB476M010RNJ
10	2	C6,C7	Cap., X5R 0.47uF 10V 10%	TAIYO YUDEN LMK107BJ474KA-T
11	4	D1,D2,D3,D4	Schottky Diode, UPS5817	MICROSEMI. UPS5817E3/TR7
12	3	JP1,JP2,JP4	Headers, 3 Pins 2mm Ctrs.	SULLINS NRPN031PAEN-RC
13	1	JP3	Headers, 4 Pins 2mm Ctrs.	SULLINS NRPN041PAEN-RC
14	1	J1	BNC Connector	Connex 112404
15	0	J2 (Opt)	Test Jacks, Shielded	Johnson Components 129-0701-201
16	4	L1,L2,L3,L4	Inductor, 2.2uH	COILCRAFT XAL5030-222MEC
17	1	Q1	P-Channel, 20V	ZETEX ZXM61P02FTA
18	1	RB1	Res., Chip 30.1K 0.06W 1%	VISHAY CRCW040230K1FKED
19	1	RILIM1	Res., Chip 69.8K 0.06W 1%	VISHAY CRCW040269K8FKED
20	1	RT1	Res., Chip 15K 0.06W 1%	VISHAY CRCW040215K0FKED
21	3	R1,R3,R6	Res., Chip 1.0M 1/16W 5%	VISHAY CRCW04021M00JNED
22	2	R5,R2	Res., Chip 10K 0.06W 5%	VISHAY CRCW040210K0JNED
23	1	R4	Res., Chip 1M 1/16W 1%	VISHAY CRCW04021M00FKED
24	2	R7,R9	Res., Chip 100K 0.06W 5%	VISHAY CRCW0402100KJNED
25	1	R8	Res., Chip 324K 1/16W 1%	VISHAY CRCW0402324KFKED
26	0	R10 (Opt)	Res., Chip 51 0.06W 5%	VISHAY CRCW040251R0JNED
27	4	TP1,TP2,TP6,TP7	Turret, Testpoint	MILL-MAX 2501-2-00-80-00-00-07-0
28	4	TP4,TP5,TP8,TP9	Turret, Testpoint	MILL-MAX 2308-2-00-80-00-00-07-0
29	1	U1	I.C., Polyphase Switching Reg.	LINEAR TECH. CORP. LTC3425EUH#PBF

# QUICK START GUIDE FOR DEMONSTRATION CIRCUIT 616

## 4MHZ, POLYPHASE HIGH EFFICIENCY SYNCHRONOUS BOOST CONVERTER

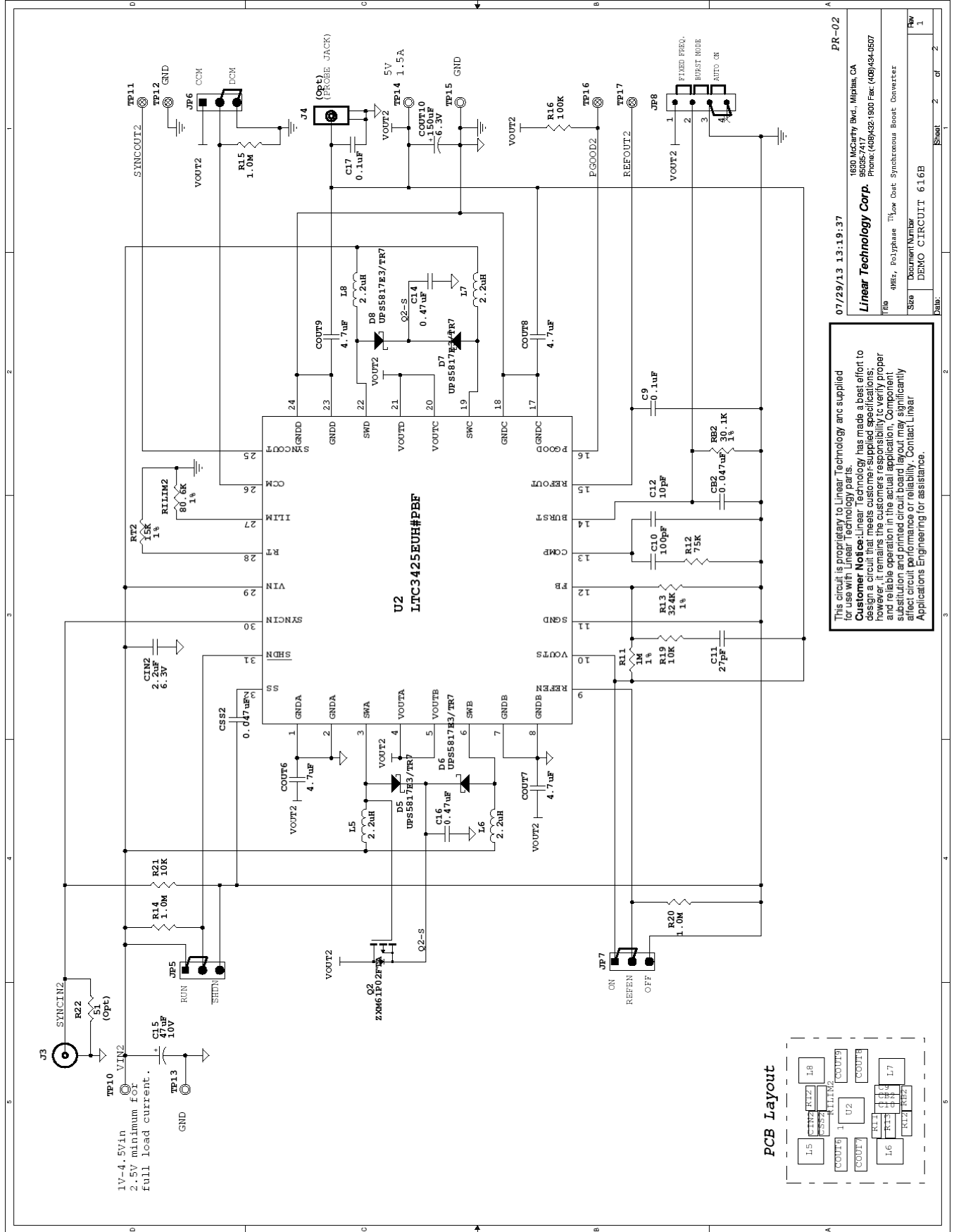

# QUICK START GUIDE FOR DEMONSTRATION CIRCUIT 616

## 4MHZ, POLYPHASE HIGH EFFICIENCY SYNCHRONOUS BOOST CONVERTER

**Vin=2.5V to 4.5V**

**Vout=5V@1.5A**

Item	Qty	Ref - Des	Part Description	Manufacturer's Part Number
1	2	CSS2,CB2	Cap., X5R 0.047uF 16V 20%	AVX 0402YD473MAT2A
2	1	CIN2	Cap., X5R 2.2uF 6.3V 10%	Taiyo Yuden JMK107BJ225KA-T
3	4	COU6,COU7,COU8,COU9	Cap., X5R 4.7uF 6.3V 20%	TAIYO YUDEN JMK212ABJ475MG-T
4	1	COU10	Cap, SP-CAP 220uF 4V .009 ohm, case size D2	PANASONIC EEFSX0G221ER
5	2	C17,C9	Cap., X5R 0.1uF 10V 10%	TDK C1005X5R1A104K
6	1	C10	Cap., NPO 220pF 25V 10%	AVX 04023A221KAT2A
7	1	C11	Cap., NPO 18pF 25V 10%	AVX 04023A180KAT2A
8	1	C12	Cap., NPO 10pF 25V 10%	AVX 04023A100KAT2A
9	0	C16,C14 (Opt)	Cap., X5R 0.47uF 10V 10%	Taiyo Yuden LMK107BJ474KA-T
10	1	C15	Cap., Tant. 47uF 10V 20%	AVX TAJB476M010RNJ
11	4	D5,D6,D7,D8 (Opt)	Schottky Diode, UPS5817	Microsemi UPS5817
12	3	JP5,JP6,JP7	Headers, 3 Pins 2mm Ctrs.	SULLINS NRPN031PAEN-RC
13	1	JP8	Headers, Commcon2802s04g2	SULLINS NRPN041PAEN-RC
14	1	J3	BNC Connector	Connex 112404
15	0	J4 (Opt)	Test Jacks, Shielded	Johnson Components 129-0701-201
16	4	L5,L6,L7,L8	Inductor, 2.2uH	muRata LQH32CN2R2M53
17	0	Q2 (Opt)	P-Channel, 20V	ZETEX ZXM61P02F
18	1	RB2	Res., Chip 30.1K 0.06W 1%	VISHAY CRCW040230K1FKED
19	1	RILIM2	Res., Chip 80.6K 0.06W 1%	VISHAY CRCW040269K8FKED
20	1	RT2	Res., Chip 15K 0.06W 1%	VISHAY CRCW040215K0FKED
21	1	R11	Res., Chip 1M 1/16W 1%	VISHAY CRCW04021M00FKED
22	1	R12	Res., Chip 200K 0.06W 5%	VISHAY CRCW0402200KJNED
23	1	R13	Res., Chip 590K 0.06W 1%	VISHAY CRCW0402590KFKED
24	3	R14,R15,R20	Res., Chip 1.0M 1/16W 5%	VISHAY CRCW04021M00JNED
25	1	R16	Res., Chip 100K 0.06W 5%	VISHAY CRCW0402100KJNED
26	2	R21,R19	Res., Chip 10K 0.06W 5%	VISHAY CRCW040210K0JNED
27	0	R22 (Opt)	Res., Chip 51 0.06W 5%	VISHAY CRCW040251R0JNED
28	4	TP10,TP13,TP14,TP15	Turret, Testpoint	MILL-MAX 2501-2-00-80-00-00-07-0
29	4	TP11,TP12,TP16,TP17	Turret, Testpoint	MILL-MAX 2308-2-00-80-00-00-07-0
30	1	U2	I.C., Polyphase Switching Reg.	LINEAR TECH. CORP. LTC3425EUH#PBF

Компания «Океан Электроники» предлагает заключение долгосрочных отношений при поставках импортных электронных компонентов на взаимовыгодных условиях!

Наши преимущества:

- Поставка оригинальных импортных электронных компонентов напрямую с производств Америки, Европы и Азии, а так же с крупнейших складов мира;
- Широкая линейка поставок активных и пассивных импортных электронных компонентов (более 30 млн. наименований);
- Поставка сложных, дефицитных, либо снятых с производства позиций;
- Оперативные сроки поставки под заказ (от 5 рабочих дней);
- Экспресс доставка в любую точку России;
- Помощь Конструкторского Отдела и консультации квалифицированных инженеров;
- Техническая поддержка проекта, помощь в подборе аналогов, поставка прототипов;
- Поставка электронных компонентов под контролем ВП;
- Система менеджмента качества сертифицирована по Международному стандарту ISO 9001;
- При необходимости вся продукция военного и аэрокосмического назначения проходит испытания и сертификацию в лаборатории (по согласованию с заказчиком);
- Поставка специализированных компонентов военного и аэрокосмического уровня качества (Xilinx, Altera, Analog Devices, Intersil, Interpoint, Microsemi, Actel, Aeroflex, Peregrine, VPT, Syfer, Eurofarad, Texas Instruments, MS Kennedy, Miteq, Cobham, E2V, MA-COM, Hittite, Mini-Circuits, General Dynamics и др.);

Компания «Океан Электроники» является официальным дистрибьютором и эксклюзивным представителем в России одного из крупнейших производителей разъемов военного и аэрокосмического назначения «JONHON», а так же официальным дистрибьютором и эксклюзивным представителем в России производителя высокотехнологичных и надежных решений для передачи СВЧ сигналов «FORSTAR».



## JONHON

«JONHON» (основан в 1970 г.)

Разъемы специального, военного и аэрокосмического назначения:

(Применяются в военной, авиационной, аэрокосмической, морской, железнодорожной, горно- и нефтедобывающей отраслях промышленности)

«FORSTAR» (основан в 1998 г.)

ВЧ соединители, коаксиальные кабели, кабельные сборки и микроволновые компоненты:

(Применяются в телекоммуникациях гражданского и специального назначения, в средствах связи, РЛС, а так же военной, авиационной и аэрокосмической отраслях промышленности).



Телефон: 8 (812) 309-75-97 (многоканальный)

Факс: 8 (812) 320-03-32

Электронная почта: [ocean@oceanchips.ru](mailto:ocean@oceanchips.ru)

Web: <http://oceanchips.ru/>

Адрес: 198099, г. Санкт-Петербург, ул. Калинина, д. 2, корп. 4, лит. А