

QMA Connectors

Snap-On SMA Series of RF Connectors

Product Facts

- Positive snap-on interface facilitates assembly
- Intermateable with competitor product
- Excellent RF performance to 6 GHz
- Ideal for Communications and Industrial Applications



Tyco Electronics' next generation high performance RF products QMA (Snap-On SMA) connectors series offers the same high quality and performance currently found in the standard Tyco Electronics SMA series but does not require the coupling nut torque. By integrating a snap-on feature to the design, denser packaging can be achieved, and the overall applied cost is dramatically reduced. The QMA connector series is excellent for communications as well as industrial applications. The QMA offering is designed for 100 mating cycles, operates through 6 GHz, and is completely intermateable with competitive QMA offerings. This new QMA product is not intermateable with standard SMA interfaces.

QMA connectors are available in a broad range of standard configurations,

including PCB and panel mount, flexible and semi-rigid cable, and adapters. Other options can be reviewed as well, including additional cable sizes, PCB surface mounting, and tape and reel packaging.

The QMA connector series is a cost effective solution for the challenging demands of today's commercial marketplace, with applications including cellular base station, handsets, and test and measurement. Call your local sales office or authorized distributor for additional information or samples of the QMA connector series.

Tyco Electronics is a leading supplier of RF and Microwave connectors and cable assemblies, and provides advanced technology products from well known and industry leading brands, including AMP and M/A-COM.

Material and Finish

- Shells and Bodies** — Brass, nickel plated
- Collars** — Phosphor bronze, white bronze plated
- Outer Contacts** — Beryllium copper, nickel plated
- Center Contacts** — Beryllium copper, gold plated
- Dielectrics** — PTFE

Electrical Characteristics

- Frequency** — dc – 6 GHz
- Nominal Impedance** — 50 ohms
- Voltage Rating** — 335 Volts (VRMS max.) @ Sea Level
- VSWR** — 1.15 : 1 max. @ 6 GHz
- Insulation Resistance** — 5,000 megohms min.
- Insertion Loss** — .25 dB Max @ 6 GHz
- Dielectric Withstanding Voltage** — 1000 Volts (VRMS max.) @ Sea Level
- Contact Resistance** — Center Contact — 5 milliohms max. Outer Contact — 4 milliohms max.

Mechanical Characteristics

- Connector Durability** — 100 mating cycles
- Force to Engage** — 27 Newtons
- Force to Disengage** — 20 Newtons
- Retention Force (mated pair)** — 60 Newtons min.
- Cable Retention** — Dependent upon cable type

Environmental Characteristics

- Temperature Rating** — -40 to +125°C
- Vibration** — EIA-364-28, Test Condition VII, Condition D
- Shock** — EIA-364-27, Method H
- Moisture Resistance** — EIA-364-31, Method III
- Thermal Shock** — EIA-364-32

Note: Performance specifications are typical, but may not apply to all connector types.

Related Product Data

- Product Specification** — 108-2087
- Sample Kit** — 1654882

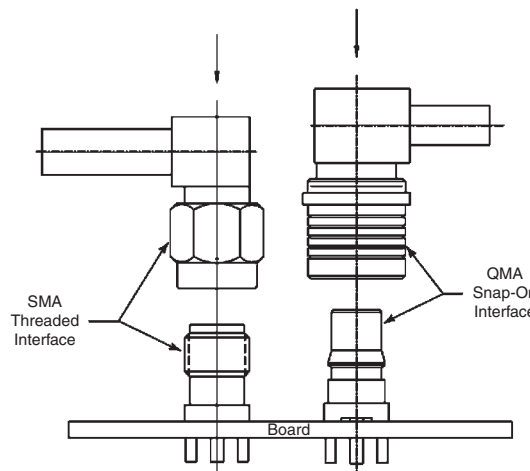

QMA Connectors (Continued)

**Semi-Rigid Cable —
Direct Solder Attachment**

Straight Cable Plug

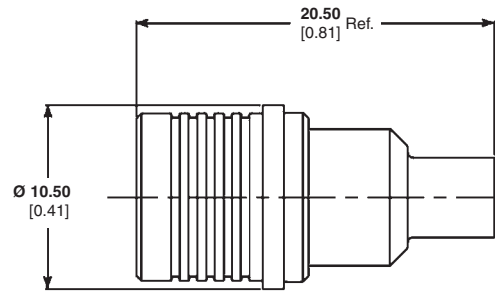

Cable	Part Number
RG 402	1408346-1

Right-Angle Cable Plug

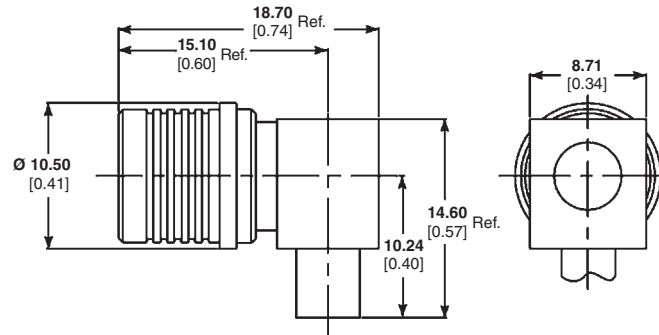

Cable	Part Number
RG 402	1408347-1

Straight Cable Jack

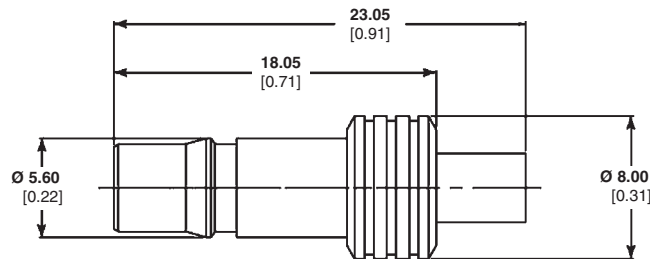

Cable	Part Number
RG 402	1408348-1

Bulkhead Cable Jack

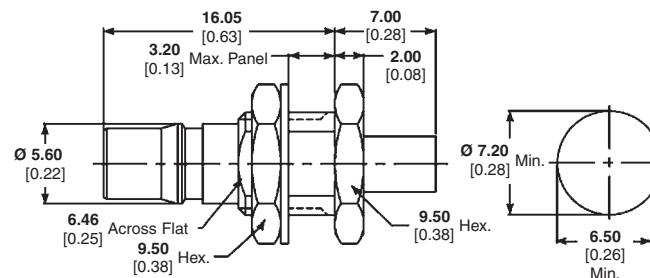

Recommended Mounting Hole

Cable	Part Number
RG 402	1408349-1

Note: Part Numbers are RoHS compliant except: ♦ Indicates non-RoHS compliant.

QMA Connectors (Continued)

Flexible Cable — Crimp Attachment

Straight Cable Plug

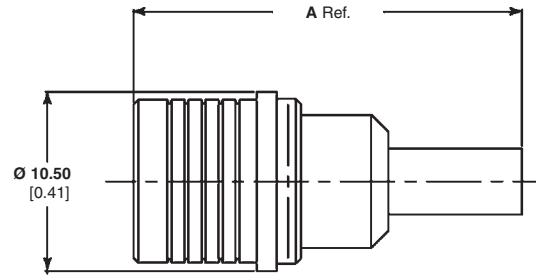

Cable	Dim. A	Part Number
RG 174, 188, 316	22.90 0.90	1408333-1
RD 316	22.90 0.90	1408333-3
RG 400	25.20 0.99	1408333-5
RG 58	25.20 0.99	1408333-7

Right-Angle Cable Plug



Cable	Dim. A	Dim. B	Part Number
RG 174, 188, 316	17.20 0.68	13.10 0.52	1408336-1
RD 316	17.20 0.68	13.10 0.52	1408336-3
RG 400	19.50 0.77	15.40 0.61	1408336-5
RG 58	19.50 0.77	15.40 0.61	1408336-7

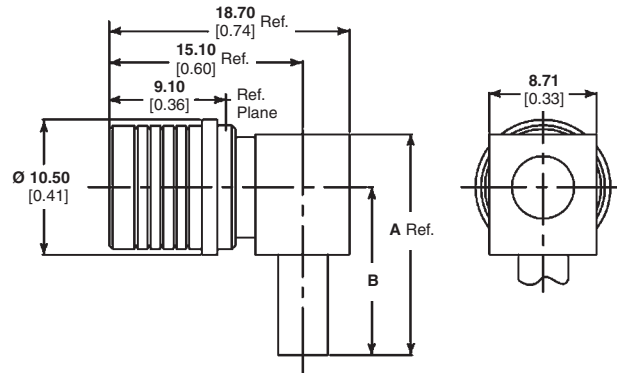

Straight Cable Jack



Cable	Dim. A	Part Number
RG 174, 188, 316	25.90 1.02	1408338-1
RD 316	25.90 1.02	1408338-3
RG 400	28.20 1.11	1408338-5
RG 58	28.20 1.11	1408338-7

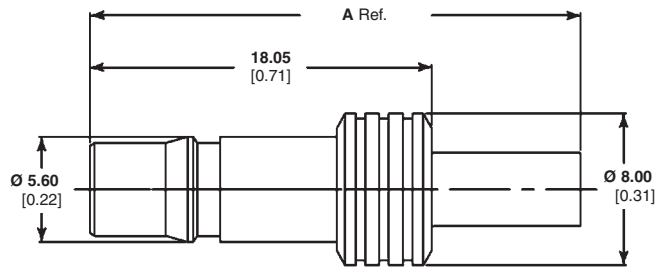

Bulkhead Cable Jack

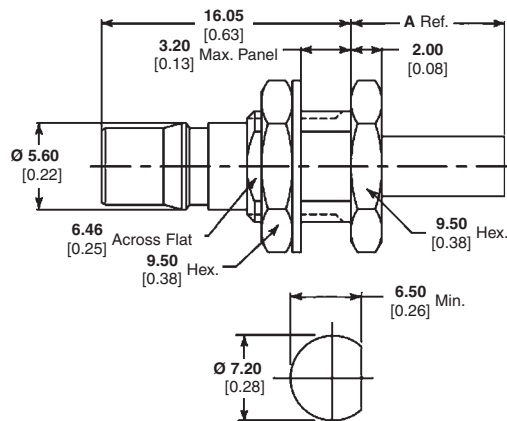

Cable	Dim. A	Part Number
RG 174, 188, 316	9.90 0.39	1408339-1
RD 316	9.90 0.39	1408339-3
RG 400	12.20 0.48	1408339-5
RG 58	12.20 0.48	1408339-7

Note: Part Numbers are RoHS compliant except: ♦ Indicates non-RoHS compliant.

Recommended Mounting Hole

QMA Connectors (Continued)

Printed Circuit Board

Straight Jack Receptacle



Part Number
1408332-1

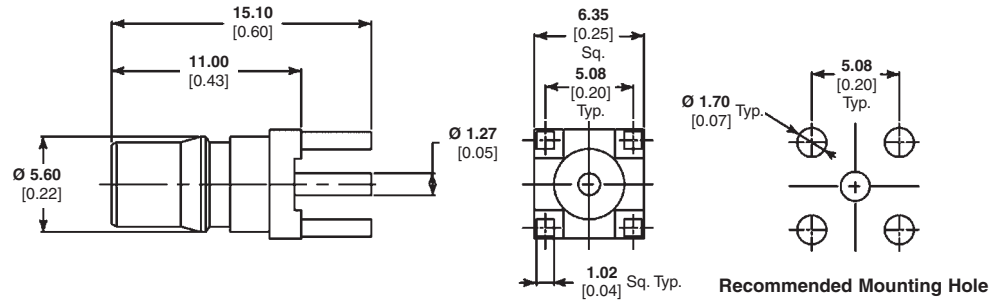

Right-Angle Jack Receptacle



Part Number
1408337-1

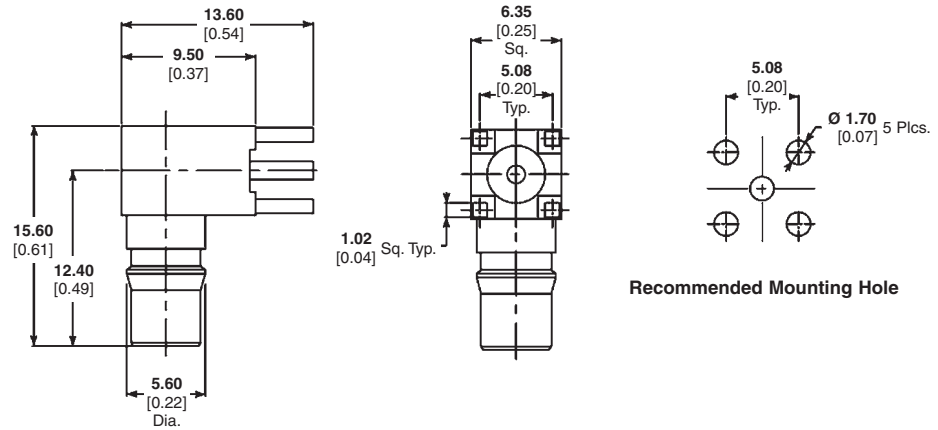

Straight Terminal Press-In Jack

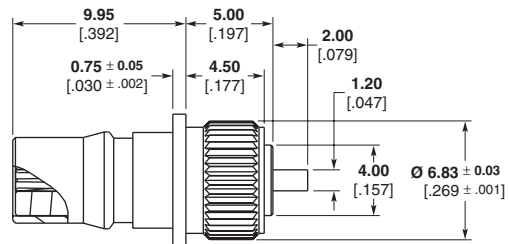

Body Material & Finish	Contact Captivation	RF Leakage db min.	Temperature Range	Part No.
Brass, Gold	Mechanical	N/A	-65 to 125° C	619215-1

Note: Part Numbers are RoHS compliant except: ♦ Indicates non-RoHS compliant.

QMA Connectors (Continued)

Straight Terminal

4-Hole Flange Mount Jack Receptacle

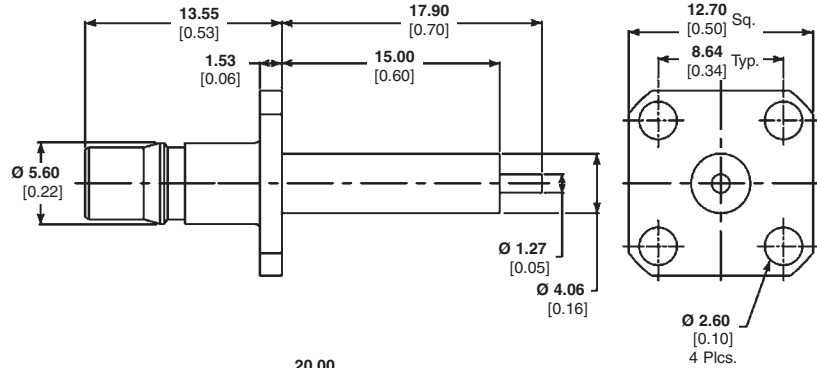

Part Number
1408341-1

Screw-In Front Mount Jack Receptacle

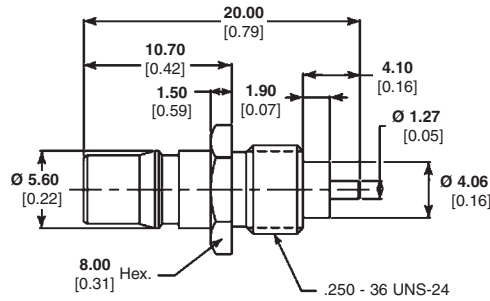

Part Number
1408340-1

Adapters — In Series

QMA Plug to QMA Jack

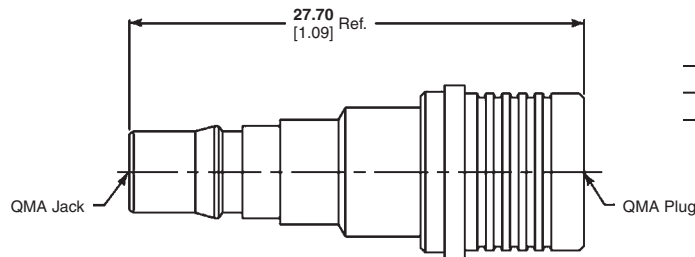

Part Number
1408342-1

Adapters — Between Series

QMA Plug to SMA Plug

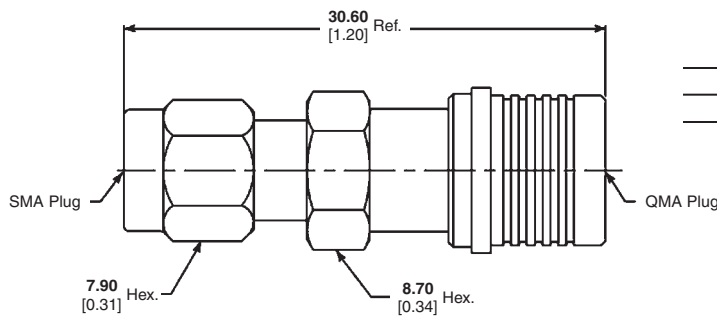

Part Number
1408393-1

QMA Jack to SMA Plug

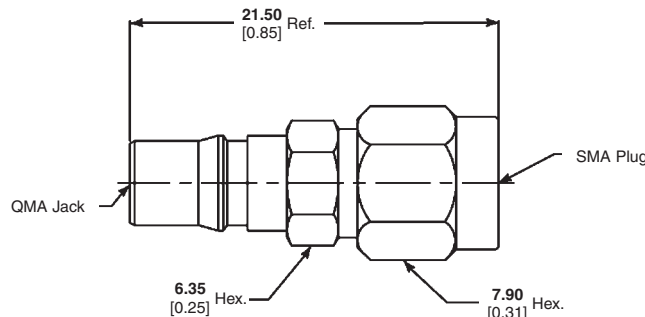

Part Number
1408343-1

Note: Part Numbers are RoHS compliant except: ♦ Indicates non-RoHS compliant.

Компания «Океан Электроники» предлагает заключение долгосрочных отношений при поставках импортных электронных компонентов на взаимовыгодных условиях!

Наши преимущества:

- Поставка оригинальных импортных электронных компонентов напрямую с производств Америки, Европы и Азии, а так же с крупнейших складов мира;
- Широкая линейка поставок активных и пассивных импортных электронных компонентов (более 30 млн. наименований);
- Поставка сложных, дефицитных, либо снятых с производства позиций;
- Оперативные сроки поставки под заказ (от 5 рабочих дней);
- Экспресс доставка в любую точку России;
- Помощь Конструкторского Отдела и консультации квалифицированных инженеров;
- Техническая поддержка проекта, помощь в подборе аналогов, поставка прототипов;
- Поставка электронных компонентов под контролем ВП;
- Система менеджмента качества сертифицирована по Международному стандарту ISO 9001;
- При необходимости вся продукция военного и аэрокосмического назначения проходит испытания и сертификацию в лаборатории (по согласованию с заказчиком);
- Поставка специализированных компонентов военного и аэрокосмического уровня качества (Xilinx, Altera, Analog Devices, Intersil, Interpoint, Microsemi, Actel, Aeroflex, Peregrine, VPT, Syfer, Eurofarad, Texas Instruments, MS Kennedy, Miteq, Cobham, E2V, MA-COM, Hittite, Mini-Circuits, General Dynamics и др.);

Компания «Океан Электроники» является официальным дистрибьютором и эксклюзивным представителем в России одного из крупнейших производителей разъемов военного и аэрокосмического назначения «**JONHON**», а так же официальным дистрибьютором и эксклюзивным представителем в России производителя высокотехнологичных и надежных решений для передачи СВЧ сигналов «**FORSTAR**».



JONHON

«**JONHON**» (основан в 1970 г.)

Разъемы специального, военного и аэрокосмического назначения:

(Применяются в военной, авиационной, аэрокосмической, морской, железнодорожной, горно- и нефтедобывающей отраслях промышленности)

«**FORSTAR**» (основан в 1998 г.)

ВЧ соединители, коаксиальные кабели, кабельные сборки и микроволновые компоненты:

(Применяются в телекоммуникациях гражданского и специального назначения, в средствах связи, РЛС, а так же военной, авиационной и аэрокосмической отраслях промышленности).



Телефон: 8 (812) 309-75-97 (многоканальный)

Факс: 8 (812) 320-03-32

Электронная почта: ocean@oceanchips.ru

Web: <http://oceanchips.ru/>

Адрес: 198099, г. Санкт-Петербург, ул. Калинина, д. 2, корп. 4, лит. А