

Daughter Board for Melexis PTC devices

## Features and Benefits

PTC04 interface board for testing devices:

- MLX91208
- MLX91209

## Applications

Experimental tool for Lab and Prototyping  
Production Equipment for Serial Programming

## Ordering Information

**Part No.**

PTC04-DBHall-05 V1.1

**Description**

Daughter Board (PCB + rear panel PTC04)

## Accessories

**Part No.**

DLL's for all supported products

User Inter Faces for supported products

Firmware for supported products

**Description**

## 1. Functional Diagram

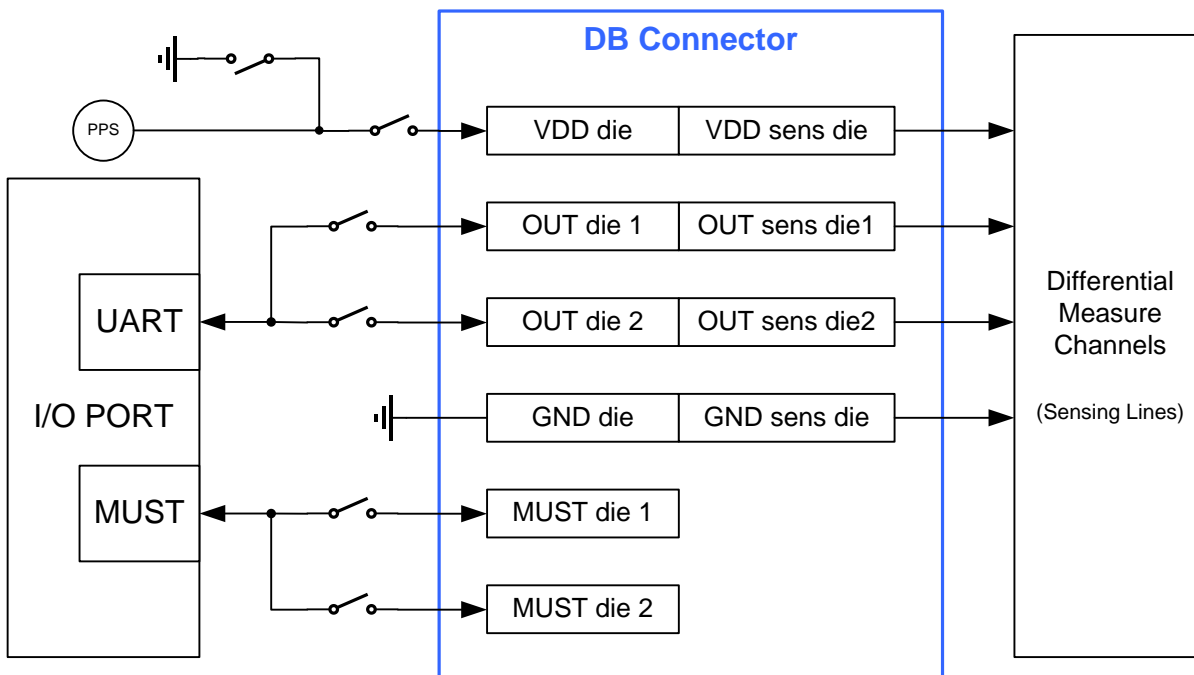

## Contents

Features and Benefits.....	1
Applications.....	1
Ordering Information .....	1
Accessories.....	1
1. Functional Diagram .....	1
2. Board description .....	3
2.1. Board Layout .....	3
2.2. Board Schematics.....	4
2.3. Daughter board Connectors.....	5
2.3.1. Digital DB Connector (40 Pins) .....	5
2.3.2. Analog DB Connector (48 Pins) .....	6
2.4. Application Connector .....	7
2.4.1. The DB15_Female connector (application connector) .....	7
2.4.2. The screw terminal .....	7
2.4.3. Force / Sense jumpers – J1.....	8
3. Contact.....	9
4. Disclaimer.....	9

## 2. Board description

### 2.1. Board Layout

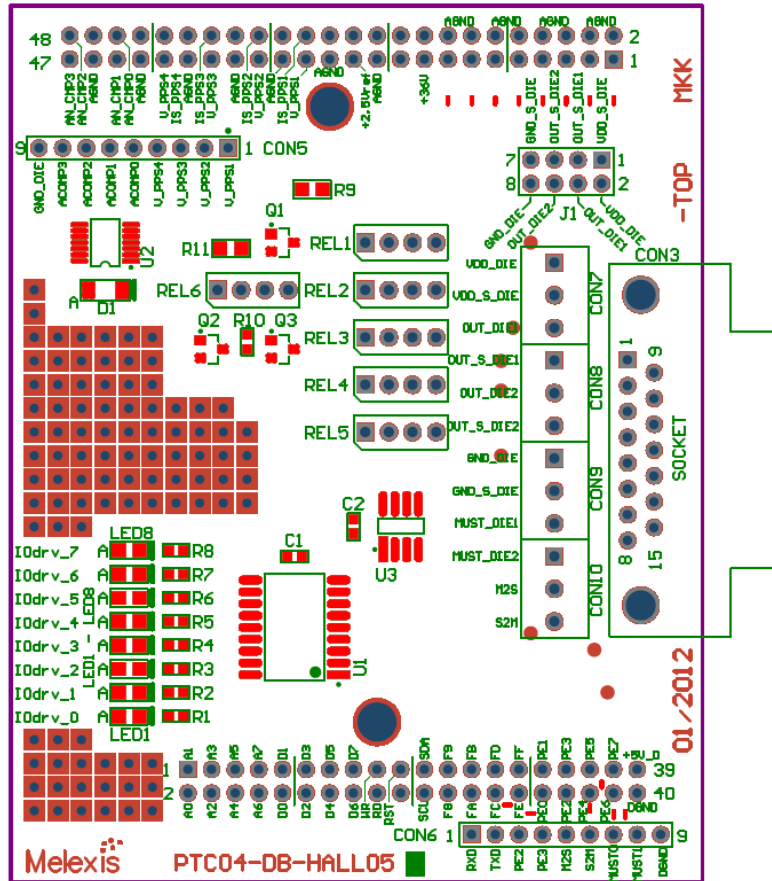

- J1: Force & Sens: Jumpers to connect the measurement sensing lines immediately to the force lines. These jumpers are needed when no force and sens is used.
- U3: DB-ID: This ID keeps a few initial variables in mind. It allows for example to detect what DB is connected to the programmer and if the DB is not expired.
- CON1 – CON2 : Analogue and Digital connector: See below for a detailed description.
- CON3: Application Connector: Dsub15 way connector to the application. See below for details.
- LED Indicators: 8 LED Indicators for the DB\_IOdrv lines.
- CON7 – 10: 12 pins Screw Terminal. It provides the same signals as the application connector.

## 2.2. Board Schematics

Below you can find the complete schematics of the DB:

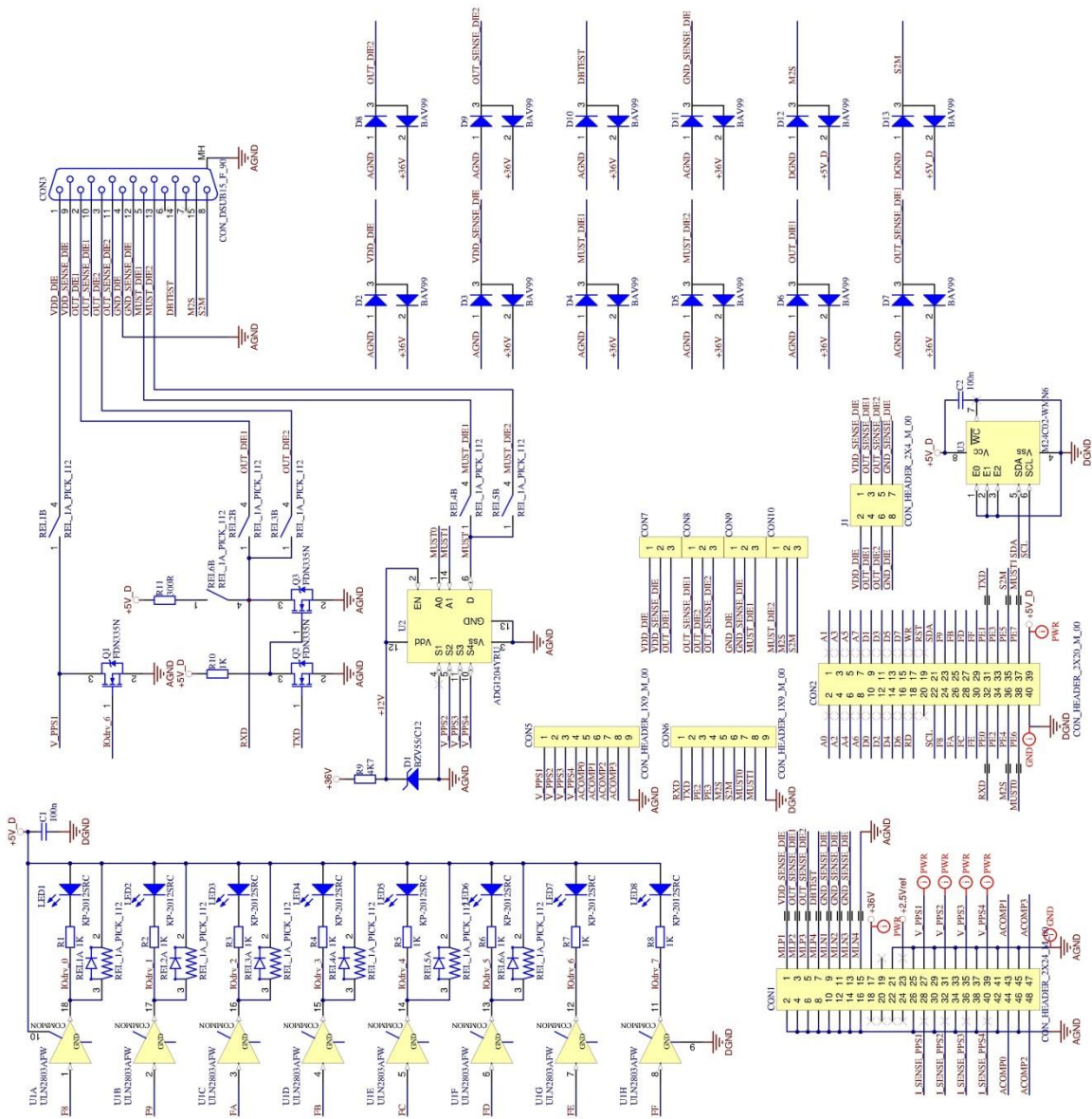

### 2.3. Daughter board Connectors

The PTC04 main board has two connectors to the interface with the application. The PTC allows adding a full PCB in between (Daughter Board). This daughter board can be mounted on the two connectors. In some exceptional cases, a daughter board contains only a few wires from the Analogue connector to the application connector. The pins on of the connectors are described below.

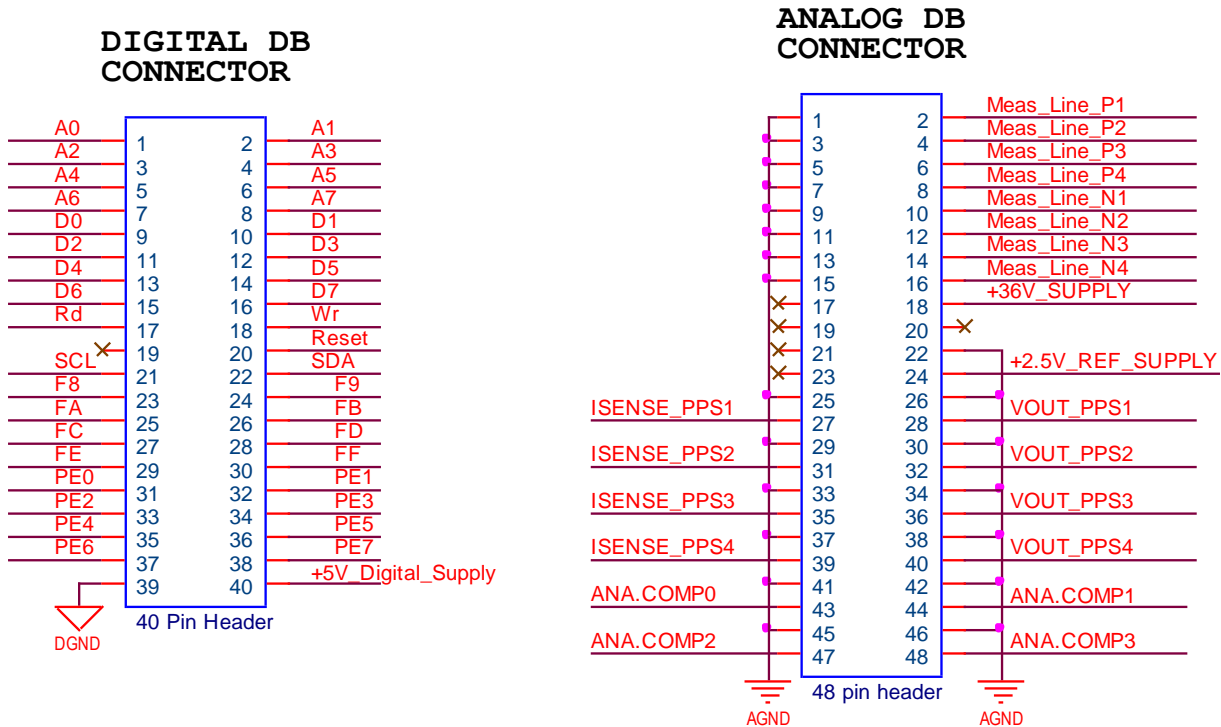

#### 2.3.1. Digital DB Connector (40 Pins)

Mainly, the digital connector is meant to expand the programmer to extra needs. Address lines A0-A7 together with the Map Select Lines F8-FF allows to direct access an area of 2 K. Examples would be adding a simple addressed I/O register by using the selection lines. If more complexity is needed, a full FPGA can be mounted on the DB board

Pins	Names	Description
1 – 8	A0 – A7	Address lines
9 – 16	D0 – D7	Data Lines active during Rd or Wr signals
17	Rd	Read: A negative pulse will indicate a sampling of the data on the Data Bus
18	Wr	Write: A Negative pulse will indicate when data is available on the Data Bus
20	Reset	This signal goes low by powering the PTC or by pressing the reset button. This line can be pulled low by application. Check firmware documentation for resetting by software.
21-22	SCL / SDA	I <sup>2</sup> C Bus
23-30	F8,F9,...,FF	CS lines when the address areas are accessed
31-38	Port E	Note: These pins are limited to 5 Volt input/output!!! The full Port E of the Atmega core is mounted to these pins. This allows us to use advanced features like PWM, UARTS, Time Measurements, etc.... By using firmware that supports these, functions, application specific requirements can be fulfilled.
39	DGND	Digital Ground
40	+5V Digital	5 Volt Digital Supply. Maximum current to get out of this supply : 250mA

Note: All the pins are limited to 5 Volt input/output!!! However, there are Protections, please take precautions in order to avoid damage of the main board.

### 2.3.2. Analog DB Connector (48 Pins)

Mainly, the analog connector provides all the analog signals and measure possibilities.

Pins	Names	Description
28,32,36	PPS 1-3	Output of the high current Programmable Supplies
40	PPS 4	Output of the Fast DAC Programmable Power Supply
27,31,35,39	Isense_PP1-4	Outputs (Driver outputs before Rsens) for current evaluations. These outputs could be used to connect to the analog comparators in order to create fast digital signals based on current.
2,4,6,8	ExtMeas1-4Pos	There are 4 differential inputs for making measurements, these are the positive inputs.
10,12,14,16	ExtMeas1-4Neg	The negative inputs of ExtMeas1- 4Pos
43,44,47,48	AnaComp0-3	Input (limited to +5V) See *Note. Fast Level comparators in order to remove time consuming measurement
18	+35V_Supply	Supply to extend the daughter board with some extra drivers
24	+2.5V_Ref	Output of internal reference
All other	AGND	Analogue Ground

Note: All the pins are limited to 35 Volt input/output!!! However, there are protections, please take precautions in order to avoid damage of the main board.

\* Note: Some pins are protected and limited to 5 Volt!!! However, there are Protections, please take precautions in order to avoid damage of the main board.

## 2.4. Application Connector

There are two ways to connect the application to PTC04:

### 2.4.1. The DB15\_Female connector (application connector)

DB15 Female Connector

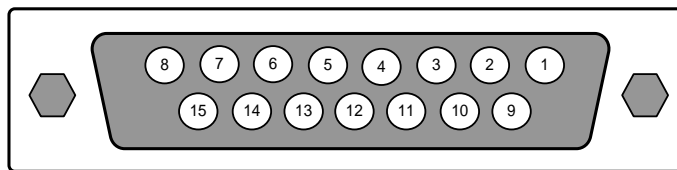

Pins	Names	Description	Package Pin #	
			91208 SOIC	91209 VA
1	VDD_DIE	Device Supply both dies	5	1
2	OUT_DIE1	Device Output Die 1	6	2
3	OUT_DIE2	Device Output Die 2	n/a	n/a
4	GND_DIE	Analogue Ground both dies	3	4
5	TEST_MUST_DIE1	Digital test pin – MUST	4	3
6	NC	Not Connected	NC	NC
7	NC	Not Connected	NC	NC
8	S2M	Master-Slave approach	n/a	n/a
9	VDD_SENS_DIE	Sensing Device Supply	5	1
10	OUT_SENS_DIE1	Sensing Device Output Die 1	6	2
11	OUT_SENS_DIE2	Sensing Device Output Die 2	n/a	n/a
12	GND_SENS_DIE	Sensing Analogue Ground Device	3	4
13	TEST_MUST_DIE2	Digital test pin – MUST	n/a	n/a
14	NC	Not Connected	NC	NC
15	M2S	Master-Slave approach	n/a	n/a

### 2.4.2. The screw terminal

Pins	Names	Description	Package Pin #	
			91208 SOIC	91209 VA
1	VDD_DIE	Device Supply	5	1
2	VDD_SENSE_DIE	Sensing Device Supply	5	1
3	OUT_DIE1	Device Output Die 1	6	2
4	OUT_SENS_DIE1	Sensing Device Output Die 1	6	2
5	OUT_DIE2	Device Output Die 2	n/a	n/a
6	OUT_SENS_DIE2	Sensing Device Output Die 2	n/a	n/a
7	GND_DIE	Analogue Ground Device	3	4
8	GND_SENSE_DIE	Sensing Analogue Ground Device	3	4
9	TEST_MUST_DIE1	Digital test pin – MUST	4	3
10	TEST_MUST_DIE2	Digital test pin – MUST	n/a	n/a
11	M2S	Master-Slave approach	n/a	n/a
12	S2M	Master-Slave approach	n/a	n/a

### 2.4.3. Force / Sense jumpers – J1

Force Pin	Names	Sense Pin #	Description
1	VDD_DIE	2	VDD_SENSE_DIE
3	OUT_DIE1	4	OUT_SENS_DIE1
5	OUT_DIE2	6	OUT_SENS_DIE2
7	GND_DIE	8	GND_SENSE_DIE



### 3. Contact

For the latest version of this document, go to our website at [www.melexis.com](http://www.melexis.com).

For additional information, please contact our Direct Sales team and get help for your specific needs:

Europe, Africa	Telephone: +32 13 67 04 95
	Email : sales_europe@melexis.com
Americas	Telephone: +1 603 223 2362
	Email : sales_usa@melexis.com
Asia	Email : sales_asia@melexis.com

### 4. Disclaimer

*The information furnished by Melexis herein ("Information") is believed to be correct and accurate. Melexis disclaims (i) any and all liability in connection with or arising out of the furnishing, performance or use of the technical data or use of the product(s) as described herein ("Product") (ii) any and all liability, including without limitation, special, consequential or incidental damages, and (iii) any and all warranties, express, statutory, implied, or by description, including warranties of fitness for particular purpose, non-infringement and merchantability. No obligation or liability shall arise or flow out of Melexis' rendering of technical or other services.*

*The Information is provided "as is" and Melexis reserves the right to change the Information at any time and without notice. Therefore, before placing orders and/or prior to designing the Product into a system, users or any third party should obtain the latest version of the relevant information to verify that the information being relied upon is current. Users or any third party must further determine the suitability of the Product for its application, including the level of reliability required and determine whether it is fit for a particular purpose.*

*The Information is proprietary and/or confidential information of Melexis and the use thereof or anything described by the Information does not grant, explicitly or implicitly, to any party any patent rights, licenses, or any other intellectual property rights.*

*This document as well as the Product(s) may be subject to export control regulations. Please be aware that export might require a prior authorization from competent authorities.*

*The Product(s) are intended for use in normal commercial applications. Unless otherwise agreed upon in writing, the Product(s) are not designed, authorized or warranted to be suitable in applications requiring extended temperature range and/or unusual environmental requirements. High reliability applications, such as medical life-support or life-sustaining equipment are specifically not recommended by Melexis.*

*The Product(s) may not be used for the following applications subject to export control regulations: the development, production, processing, operation, maintenance, storage, recognition or proliferation of 1) chemical, biological or nuclear weapons, or for the development, production, maintenance or storage of missiles for such weapons; 2) civil firearms, including spare parts or ammunition for such arms; 3) defense related products, or other material for military use or for law enforcement; 4) any applications that, alone or in combination with other goods, substances or organisms could cause serious harm to persons or goods and that can be used as a means of violence in an armed conflict or any similar violent situation.*

*The Products sold by Melexis are subject to the terms and conditions as specified in the Terms of Sale, which can be found at <https://www.melexis.com/en/legal/terms-and-conditions>.*

*This document supersedes and replaces all prior information regarding the Product(s) and/or previous versions of this document.*

*Melexis NV © - No part of this document may be reproduced without the prior written consent of Melexis. (2016)*

*ISO/TS 16949 and ISO14001 Certified*

Компания «Океан Электроники» предлагает заключение долгосрочных отношений при поставках импортных электронных компонентов на взаимовыгодных условиях!

Наши преимущества:

- Поставка оригинальных импортных электронных компонентов напрямую с производств Америки, Европы и Азии, а так же с крупнейших складов мира;
- Широкая линейка поставок активных и пассивных импортных электронных компонентов (более 30 млн. наименований);
- Поставка сложных, дефицитных, либо снятых с производства позиций;
- Оперативные сроки поставки под заказ (от 5 рабочих дней);
- Экспресс доставка в любую точку России;
- Помощь Конструкторского Отдела и консультации квалифицированных инженеров;
- Техническая поддержка проекта, помощь в подборе аналогов, поставка прототипов;
- Поставка электронных компонентов под контролем ВП;
- Система менеджмента качества сертифицирована по Международному стандарту ISO 9001;
- При необходимости вся продукция военного и аэрокосмического назначения проходит испытания и сертификацию в лаборатории (по согласованию с заказчиком);
- Поставка специализированных компонентов военного и аэрокосмического уровня качества (Xilinx, Altera, Analog Devices, Intersil, Interpoint, Microsemi, Actel, Aeroflex, Peregrine, VPT, Syfer, Eurofarad, Texas Instruments, MS Kennedy, Miteq, Cobham, E2V, MA-COM, Hittite, Mini-Circuits, General Dynamics и др.);

Компания «Океан Электроники» является официальным дистрибьютором и эксклюзивным представителем в России одного из крупнейших производителей разъемов военного и аэрокосмического назначения «JONHON», а так же официальным дистрибьютором и эксклюзивным представителем в России производителя высокотехнологичных и надежных решений для передачи СВЧ сигналов «FORSTAR».



## JONHON

«JONHON» (основан в 1970 г.)

Разъемы специального, военного и аэрокосмического назначения:

(Применяются в военной, авиационной, аэрокосмической, морской, железнодорожной, горно- и нефтедобывающей отраслях промышленности)

«FORSTAR» (основан в 1998 г.)

ВЧ соединители, коаксиальные кабели, кабельные сборки и микроволновые компоненты:

(Применяются в телекоммуникациях гражданского и специального назначения, в средствах связи, РЛС, а так же военной, авиационной и аэрокосмической отраслях промышленности).



Телефон: 8 (812) 309-75-97 (многоканальный)

Факс: 8 (812) 320-03-32

Электронная почта: [ocean@oceanchips.ru](mailto:ocean@oceanchips.ru)

Web: <http://oceanchips.ru/>

Адрес: 198099, г. Санкт-Петербург, ул. Калинина, д. 2, корп. 4, лит. А