

General-purpose Threaded Capacitive Sensor

- Product lineup with M12, M18, and M30 models.
- Fixed sensing distance requires no sensitivity adjustment.



 Be sure to read *Safety Precautions* on page 5.

Ordering Information

Sensors [Refer to *Dimensions* on page 6.]

Appearance		Sensing distance		Output configuration	Model	
					Operation mode	
					NO	NC
Unshielded 	M12	4 mm		DC 3-wire, NPN	E2K-X4ME1 2M	E2K-X4ME2 2M
				DC 3-wire, PNP	E2K-X4MF1 2M	E2K-X4MF2 2M
				AC 2-wire	E2K-X4MY1 2M	E2K-X4MY2 2M
	M18	8 mm		DC 3-wire, NPN	E2K-X8ME1 2M	E2K-X8ME2 2M
				DC 3-wire, PNP	E2K-X8MF1 2M	E2K-X8MF2 2M
				AC 2-wire	E2K-X8MY1 2M	E2K-X8MY2 2M
	M30	15 mm		DC 3-wire, NPN	E2K-X15ME1 2M	E2K-X15ME2 2M
				DC 3-wire, PNP	E2K-X15MF1 2M	E2K-X15MF2 2M
				AC 2-wire	E2K-X15MY1 2M	E2K-X15MY2 2M

Accessories (Order Separately)

Mounting Brackets

Refer to Y92□ for details.

Ratings and Specifications

Item	Model	E2K-X4ME□, E2K-X4MF□, E2K-X4MY□	E2K-X8ME□, E2K-X8MF□, E2K-X8MY□	E2K-X15ME□, E2K-X15MF□, E2K-X15MY□
Sensing distance		4mm ±10%	8 mm ±10%	15 mm ±10%
Set distance *1		0 to 2.8 mm	0 to 5.6 mm	0 to 10 mm
Differential travel		4% to 20% of sensing distance		
Detectable object		Conductors and dielectrics		
Standard sensing object		Grounded metal plate: 50 × 50 × 1 mm		
Response frequency		E and F Models: 100 Hz, Y Models: 10 Hz		
Power supply voltage*2 (operating voltage range)		E and F Models: 12 to 24 VDC (10 to 30 VDC) Y Models: 100 to 220 VAC (90 to 250 VAC)		
Current consumption		E and F Models: 15 mA max.		
Leakage current		Y Models: 2.2 mA max. (Refer to page 4.)		
Control output	Load current	E and F Models: 200 mA max. *2, Y Models: 10 to 200 mA		
	Residual voltage	E and F Models: 1 V max. (Load current: 200 mA, Cable length: 2 m), Y Models: Refer to <i>Engineering Data</i> on page 4.		
Indicators		E and F Models: Detection indicator (red), Y Models: Operation indicator (red)		
Operation mode (with sensing object approaching)		E1, F1, and Y1 Models: NO E2, F2, and Y2 Models: NC Refer to the timing charts under <i>I/O Circuit Diagrams</i> on page 4 for details.		
Protection circuits		E and F Models: Reverse polarity protection, Surge suppressor, Y Models: Surge suppressor		
Ambient temperature range		Operating/Storage: -25 to 70°C (with no icing or condensation)		Operating/Storage: -10 to 55°C (with no icing or condensation)
Ambient humidity range		Operating/Storage: 35% to 95% (with no condensation)		
Temperature influence		±20% max. of sensing distance at 23°C in the operating temperature range		
Voltage influence		E and F Models: ±2% max. of sensing distance at rated voltage at rated voltage ±20% Y Models: ±2% max. of sensing distance at rated voltage at rated voltage ±10%		
Insulation resistance		50 MΩ min. (at 500 VDC) between current-carrying parts and case		
Dielectric strength		E and F Models: 1,000 VAC, 50/60 Hz for 1 min between current-carrying parts and case Y Models: 2,000 VAC, 50/60 Hz for 1 min between current-carrying parts and case		
Vibration resistance		Destruction: 10 to 55 Hz, 1.5-mm double amplitude for 2 hours each in X, Y, and Z directions		
Shock resistance		Destruction: 500 m/s ² 3 times each in X, Y, and Z directions		
Degree of protection		IP66 (IEC), in-house standards: oil-resistant		
Connection method		Pre-wired Models (Standard cable length: 2 m)		
Weight (packed state)		Approx. 65 g	Approx. 145 g	Approx. 205 g
Materials	Case	Heat-resistant ABS		
	Sensing surface	Polyacetal		
	Clamping nuts	Polyacetal		
Accessories		Instruction manual		

*1. The above values are sensing distances for the standard sensing object. Refer to *Engineering Data* on page 3 for other materials.

*2. E and F Models (DC switching models): A full-wave rectification power supply of 24 VDC ±20% (average value) can be used.

Engineering Data (Reference Value)

Sensing Area (Grounded Metal Plate)

E2K-X4M

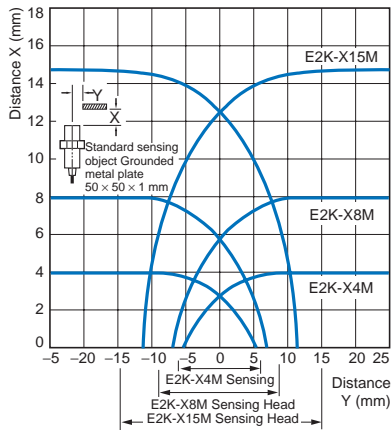

Influence of Sensing Object Size and Material

E2K-X4M

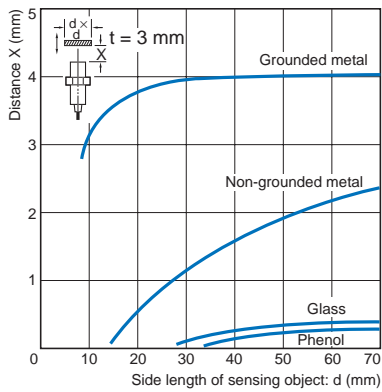

E2K-X8M

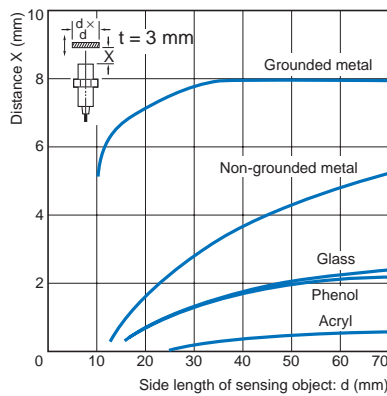

E2K-X15M

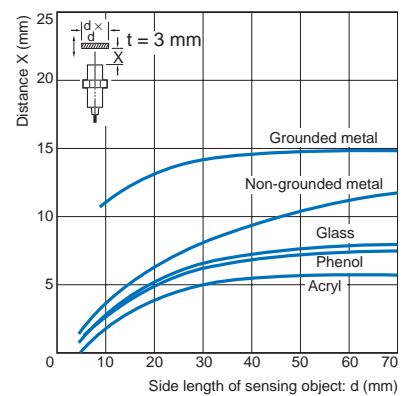

Sensing Object Thickness and Material vs. Sensing Distance

E2K-X4M

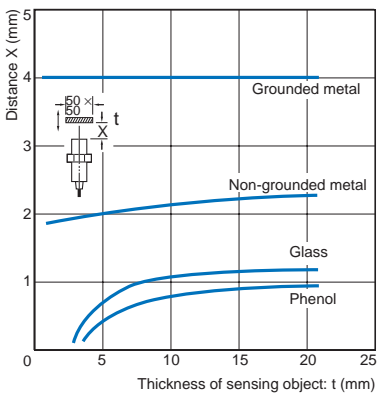

E2K-X8M

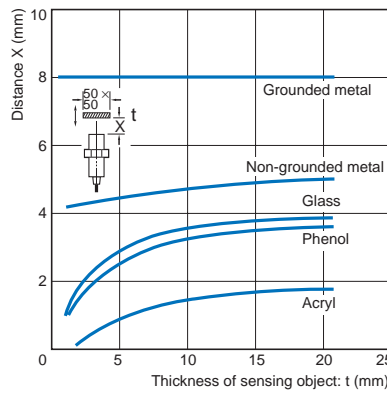

E2K-X15M

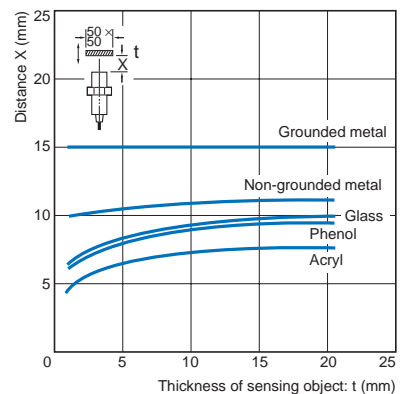

Leakage Current

E2K-X□MY

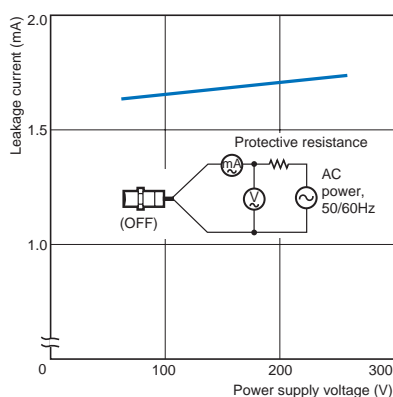

Residual Output Voltage

E2K-X□MY□

at 100 VAC

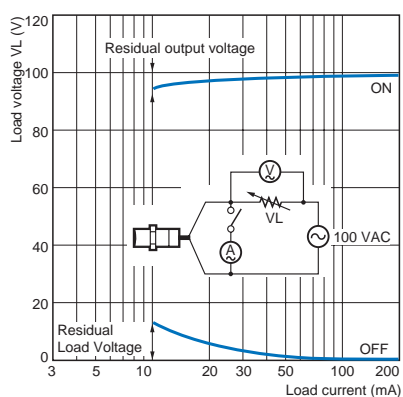

E2K-X□MY□

at 200 VAC

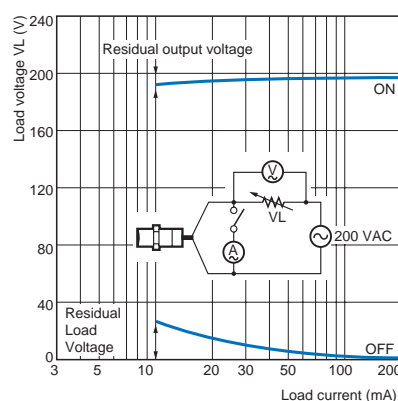

I/O Circuit Diagrams

DC 3-Wire Models (NPN)

Operation mode	Model	Timing chart	Output circuit
NO	E2K-X4ME1 E2K-X8ME1 E2K-X15ME1	<p>Sensing object: Present (ON), Not present (OFF)</p> <p>Load (between brown and black leads): Operate (ON), Reset (OFF)</p> <p>Output voltage (between black and blue leads): High (ON), Low (OFF)</p> <p>Detection indicator (red): ON (ON), OFF (OFF)</p>	<p>*1. Load current: 200 mA max. *2. When a transistor is connected.</p>
NC	E2K-X4ME2 E2K-X8ME2 E2K-X15ME2	<p>Sensing object: Present (ON), Not present (OFF)</p> <p>Load (between brown and black leads): Operate (ON), Reset (OFF)</p> <p>Output voltage (between black and blue leads): High (ON), Low (OFF)</p> <p>Detection indicator (red): ON (ON), OFF (OFF)</p>	<p>*1. Load current: 200 mA max. *2. When a transistor is connected.</p>

DC 3-Wire Models (PNP)

Operation mode	Model	Timing chart	Output circuit
NO	E2K-X4MF1 E2K-X8MF1 E2K-X15MF1	<p>Sensing object: Present (ON), Not present (OFF)</p> <p>Load (between blue and black leads): Operate (ON), Reset (OFF)</p> <p>Output voltage (between black and brown leads): High (ON), Low (OFF)</p> <p>Detection indicator (red): ON (ON), OFF (OFF)</p>	<p>*1. Load current: 200 mA max. *2. When a transistor is connected.</p>
NC	E2K-X4MF2 E2K-X8MF2 E2K-X15MF2	<p>Sensing object: Present (ON), Not present (OFF)</p> <p>Load (between blue and black leads): Operate (ON), Reset (OFF)</p> <p>Output voltage (between black and brown leads): High (ON), Low (OFF)</p> <p>Detection indicator (red): ON (ON), OFF (OFF)</p>	<p>*1. Load current: 200 mA max. *2. When a transistor is connected.</p>

AC 2-Wire Models

Operation mode	Model	Timing chart	Output circuit
NO	E2K-X4MY1 E2K-X8MY1 E2K-X15MY1	<p>Sensing object: Present (ON), Not present (OFF)</p> <p>Load: Operate (ON), Reset (OFF)</p> <p>Operation indicator (red): ON (ON), OFF (OFF)</p>	
NC	E2K-X4MY2 E2K-X8MY2 E2K-X15MY2	<p>Sensing object: Present (ON), Not present (OFF)</p> <p>Load: Operate (ON), Reset (OFF)</p> <p>Operation indicator (red): ON (ON), OFF (OFF)</p>	

Safety Precautions

Refer to *Warranty and Limitations of Liability*.

⚠ WARNING

This product is not designed or rated for ensuring safety of persons either directly or indirectly. Do not use it for such purposes.



Precautions for Correct Use

Do not use this product under ambient conditions that exceed the ratings.

● Design

Ambient Environment

The Sensor may malfunction if subjected to water, oil, chemicals, or condensation by falsely detecting these as sensing objects. The E2K-X15M is highly sensitive to inductive objects and can thus be affected even by small quantities of water drops.

Influence of Surrounding Objects

If the Sensor is embedded in metal, maintain at least the following distances between the Sensor and the metal. The Sensor is also affected by other materials, such as resins. Separate the Sensor from other materials by the same distance as for metal.

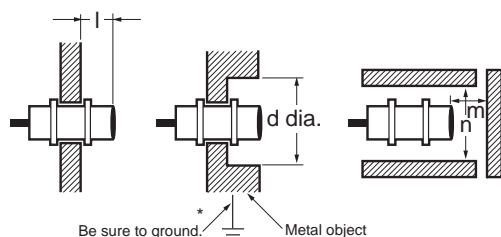

* Be sure to ground the metal object, otherwise Sensor operation will not be stable.

Influence of Surrounding Metal (Unit: mm)

Model	Dimension	l	d	m	n
E2K-X4M	20	50	8	12	60
E2K-X8M					
E2K-X15M	10		25		

If a mounting bracket is used, be sure that at least the following distances are maintained.

Influence of Surrounding Metal

(Unit: mm)

Model	Dimension	G	H
E2K-X4M	20	30	30
E2K-X8M			
E2K-X15M	10		

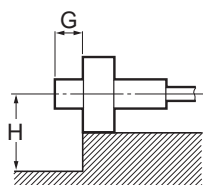

Mutual Interference

When installing Sensors face-to-face or side-by-side, ensure that the minimum distances given in the following table are maintained.

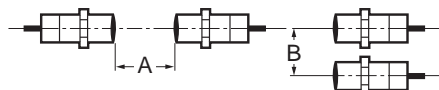

Mutual Interference (Unit: mm)

Model	Dimension	A	B
E2K-X4M		80	70
E2K-X8M		150	110
E2K-X15M		300	200

Sensing Objects

The maximum sensing distance will decrease if the sensing object is a non-grounded metal object or dielectric object.

- Sensing Object Material
The E2K-X can detect almost any type of object. The sensing distance of the E2K-X, however, will vary with the electrical characteristics of the object, such as the conductance and inductance of the object, and the water content and capacity of the object. The maximum sensing distance of the E2K-X will be obtained if the object is made of grounded metal.
- There are objects that cannot be detected indirectly. Therefore, be sure to test the E2K-X in a trial operation with the objects before using the E2K-X in actual applications.

Effects of a High-frequency Electromagnetic Field

The E2K-X may malfunction if there is an ultrasonic washer, high-frequency generator, transceiver, or inverter nearby. For major measures, refer to *Noise of Warranty and Limitations of Liability* for Photoelectric Sensors.

Mounting

Do not tighten the nut with excessive force. Always use washers when tightening the nuts and do not exceed the torque in the following table.

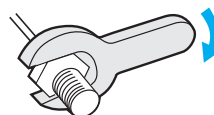

Model	Torque
E2K-X4M	0.78 N·m
E2K-X8M	2 N·m
E2K-X15M	

● Miscellaneous

Organic Solvents

The Sensor has a case made of heat-resistant ABS resin. Be sure that the case is free from organic solvents or solutions containing organic solvents.

Dimensions

Tolerance class IT16 applies to dimensions in this data sheet unless otherwise specified.

- E2K-X4ME□
- E2K-X4MF□
- E2K-X4MY□

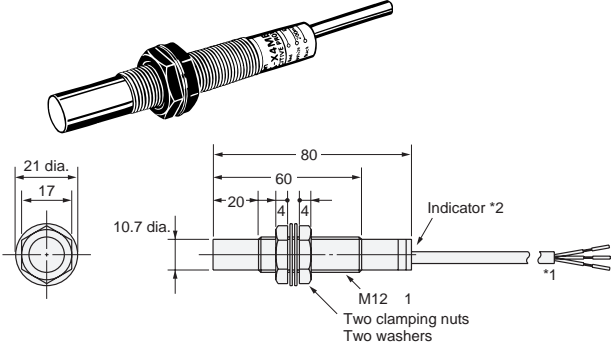

*1. E and F Models: 4-dia. vinyl-insulated round cable with 3 conductors (Conductor cross section: 0.2 mm², Insulator diameter: 1.2 mm), Standard length: 2 m
 Y Models: 4-dia. vinyl-insulated round cable with 2 conductors (Conductor cross section: 0.3 mm², Insulator diameter: 1.3 mm), Standard length: 2 m
 *2. E and F Models: Detection indicator (red)
 Y Models: Operation indicator (red)

- E2K-X8ME□
- E2K-X8MF□
- E2K-X8MY□

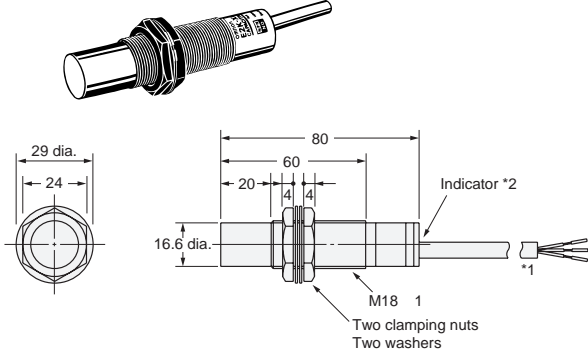

*1. E and F Models: 6-dia. vinyl-insulated round cable with 3 conductors (Conductor cross section: 0.5 mm², Insulator diameter: 1.9 mm), Standard length: 2 m
 Y Models: 6-dia. vinyl-insulated round cable with 2 conductors (Conductor cross section: 0.5 mm², Insulator diameter: 1.9 mm), Standard length: 2 m
 *2. E and F Models: Detection indicator (red)
 Y Models: Operation indicator (red)

- E2K-X15ME□
- E2K-X15MF□
- E2K-X15MY□

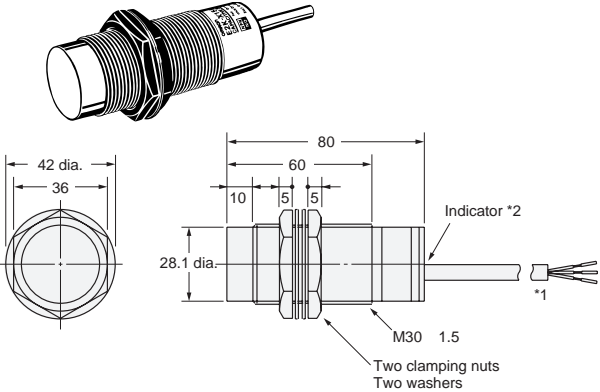

*1. E and F Models: 6-dia. vinyl-insulated round cable with 3 conductors (Conductor cross section: 0.5 mm², Insulator diameter: 1.9 mm), Standard length: 2 m
 Y Models: 6-dia. vinyl-insulated round cable with 2 conductors (Conductor cross section: 0.5 mm², Insulator diameter: 1.9 mm), Standard length: 2 m
 *2. E and F Models: Detection indicator (red)
 Y Models: Operation indicator (red)

Mounting Hole Dimensions

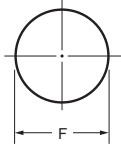

Model	F (mm)
E2K-X4M□□	12.5 ^{+0.5} ₀ dia.
E2K-X8M□□	18.5 ^{+0.5} ₀ dia.
E2K-X15M□□	30.5 ^{+0.5} ₀ dia.

Read and Understand This Catalog

Please read and understand this catalog before purchasing the products. Please consult your OMRON representative if you have any questions or comments.

Warranty and Limitations of Liability

WARRANTY

OMRON's exclusive warranty is that the products are free from defects in materials and workmanship for a period of one year (or other period if specified) from date of sale by OMRON.

OMRON MAKES NO WARRANTY OR REPRESENTATION, EXPRESS OR IMPLIED, REGARDING NON-INFRINGEMENT, MERCHANTABILITY, OR FITNESS FOR PARTICULAR PURPOSE OF THE PRODUCTS. ANY BUYER OR USER ACKNOWLEDGES THAT THE BUYER OR USER ALONE HAS DETERMINED THAT THE PRODUCTS WILL SUITABLY MEET THE REQUIREMENTS OF THEIR INTENDED USE. OMRON DISCLAIMS ALL OTHER WARRANTIES, EXPRESS OR IMPLIED.

LIMITATIONS OF LIABILITY

OMRON SHALL NOT BE RESPONSIBLE FOR SPECIAL, INDIRECT, OR CONSEQUENTIAL DAMAGES, LOSS OF PROFITS OR COMMERCIAL LOSS IN ANY WAY CONNECTED WITH THE PRODUCTS, WHETHER SUCH CLAIM IS BASED ON CONTRACT, WARRANTY, NEGLIGENCE, OR STRICT LIABILITY.

In no event shall the responsibility of OMRON for any act exceed the individual price of the product on which liability is asserted.

IN NO EVENT SHALL OMRON BE RESPONSIBLE FOR WARRANTY, REPAIR, OR OTHER CLAIMS REGARDING THE PRODUCTS UNLESS OMRON'S ANALYSIS CONFIRMS THAT THE PRODUCTS WERE PROPERLY HANDLED, STORED, INSTALLED, AND MAINTAINED AND NOT SUBJECT TO CONTAMINATION, ABUSE, MISUSE, OR INAPPROPRIATE MODIFICATION OR REPAIR.

Application Considerations

SUITABILITY FOR USE

OMRON shall not be responsible for conformity with any standards, codes, or regulations that apply to the combination of products in the customer's application or use of the products.

At the customer's request, OMRON will provide applicable third party certification documents identifying ratings and limitations of use that apply to the products. This information by itself is not sufficient for a complete determination of the suitability of the products in combination with the end product, machine, system, or other application or use.

The following are some examples of applications for which particular attention must be given. This is not intended to be an exhaustive list of all possible uses of the products, nor is it intended to imply that the uses listed may be suitable for the products:

- Outdoor use, uses involving potential chemical contamination or electrical interference, or conditions or uses not described in this catalog.
- Nuclear energy control systems, combustion systems, railroad systems, aviation systems, medical equipment, amusement machines, vehicles, safety equipment, and installations subject to separate industry or government regulations.
- Systems, machines, and equipment that could present a risk to life or property.

Please know and observe all prohibitions of use applicable to the products.

NEVER USE THE PRODUCTS FOR AN APPLICATION INVOLVING SERIOUS RISK TO LIFE OR PROPERTY WITHOUT ENSURING THAT THE SYSTEM AS A WHOLE HAS BEEN DESIGNED TO ADDRESS THE RISKS, AND THAT THE OMRON PRODUCTS ARE PROPERLY RATED AND INSTALLED FOR THE INTENDED USE WITHIN THE OVERALL EQUIPMENT OR SYSTEM.

PROGRAMMABLE PRODUCTS

OMRON shall not be responsible for the user's programming of a programmable product, or any consequence thereof.

Disclaimers

CHANGE IN SPECIFICATIONS

Product specifications and accessories may be changed at any time based on improvements and other reasons.

It is our practice to change model numbers when published ratings or features are changed, or when significant construction changes are made. However, some specifications of the products may be changed without any notice. When in doubt, special model numbers may be assigned to fix or establish key specifications for your application on your request. Please consult with your OMRON representative at any time to confirm actual specifications of purchased products.

DIMENSIONS AND WEIGHTS

Dimensions and weights are nominal and are not to be used for manufacturing purposes, even when tolerances are shown.

PERFORMANCE DATA

Performance data given in this catalog is provided as a guide for the user in determining suitability and does not constitute a warranty. It may represent the result of OMRON's test conditions, and the users must correlate it to actual application requirements. Actual performance is subject to the OMRON Warranty and Limitations of Liability.

ERRORS AND OMISSIONS

The information in this document has been carefully checked and is believed to be accurate; however, no responsibility is assumed for clerical, typographical, or proofreading errors, or omissions.

2012.10

In the interest of product improvement, specifications are subject to change without notice.

OMRON Corporation
Industrial Automation Company

<http://www.ia.omron.com/>

(c)Copyright OMRON Corporation 2012 All Right Reserved.

Компания «Океан Электроники» предлагает заключение долгосрочных отношений при поставках импортных электронных компонентов на взаимовыгодных условиях!

Наши преимущества:

- Поставка оригинальных импортных электронных компонентов напрямую с производств Америки, Европы и Азии, а так же с крупнейших складов мира;
- Широкая линейка поставок активных и пассивных импортных электронных компонентов (более 30 млн. наименований);
- Поставка сложных, дефицитных, либо снятых с производства позиций;
- Оперативные сроки поставки под заказ (от 5 рабочих дней);
- Экспресс доставка в любую точку России;
- Помощь Конструкторского Отдела и консультации квалифицированных инженеров;
- Техническая поддержка проекта, помощь в подборе аналогов, поставка прототипов;
- Поставка электронных компонентов под контролем ВП;
- Система менеджмента качества сертифицирована по Международному стандарту ISO 9001;
- При необходимости вся продукция военного и аэрокосмического назначения проходит испытания и сертификацию в лаборатории (по согласованию с заказчиком);
- Поставка специализированных компонентов военного и аэрокосмического уровня качества (Xilinx, Altera, Analog Devices, Intersil, Interpoint, Microsemi, Actel, Aeroflex, Peregrine, VPT, Syfer, Eurofarad, Texas Instruments, MS Kennedy, Miteq, Cobham, E2V, MA-COM, Hittite, Mini-Circuits, General Dynamics и др.);

Компания «Океан Электроники» является официальным дистрибьютором и эксклюзивным представителем в России одного из крупнейших производителей разъемов военного и аэрокосмического назначения «JONHON», а так же официальным дистрибьютором и эксклюзивным представителем в России производителя высокотехнологичных и надежных решений для передачи СВЧ сигналов «FORSTAR».



JONHON

«JONHON» (основан в 1970 г.)

Разъемы специального, военного и аэрокосмического назначения:

(Применяются в военной, авиационной, аэрокосмической, морской, железнодорожной, горно- и нефтедобывающей отраслях промышленности)

«FORSTAR» (основан в 1998 г.)

ВЧ соединители, коаксиальные кабели,
кабельные сборки и микроволновые компоненты:

(Применяются в телекоммуникациях гражданского и специального назначения, в средствах связи, РЛС, а так же военной, авиационной и аэрокосмической отраслях промышленности).



Телефон: 8 (812) 309-75-97 (многоканальный)

Факс: 8 (812) 320-03-32

Электронная почта: ocean@oceanchips.ru

Web: <http://oceanchips.ru/>

Адрес: 198099, г. Санкт-Петербург, ул. Калинина, д. 2, корп. 4, лит. А