

Features

- Beam-Lead Device
- No Wirebonds Required
- Rugged Silicon-Glass Construction
- Silicon Nitride Passivation
- Polymer Scratch and Impact Protection
- Low Parasitic Capacitance and Inductance
- Ultra Low Capacitance < 40 fF
- Excellent RC Product < 0.10 pS
- High Switching Cutoff Frequency > 110 GHz
- 110 Nanosecond Minority Carrier Lifetime
- Driven by Standard +5V TTL PIN Diode Driver

Description

This device is a Silicon-Glass Beam-Lead PIN diode fabricated with M/A-COM's patented HMIC™ process. This device features one silicon pedestal embedded in a low loss, low dispersion glass which supports the beam-leads. The diode is formed on the top of the pedestal, and airbridges connect the diode to the beam-leads. The topside is fully encapsulated with silicon nitride and has an additional polymer layer for scratch and impact protection. These protective coatings prevent damage to the junction and the air-bridges during handling and assembly.

The diodes themselves exhibit low series resistance, low capacitance, and extremely fast switching speed.

Applications

The ultra low capacitance of this device allows use through W-band (110 GHz) applications. The low RC product and low profile of the PIN diodes makes it ideal for use in microwave and millimeter wave switch designs, where lower insertion loss and higher isolation are required. The + 10 mA (low loss state) and the 0v (isolation state) bias of the diodes allows the use a simple + 5V TTL gate driver. These diodes are used as switching arrays on radar systems, high-speed ECM circuits, optical switching networks, instrumentation, and other wideband multi-throw switch assemblies.

Absolute Maximum Ratings¹

@ T_A = +25°C (Unless otherwise specified)

Parameter	Absolute Maximum
Forward Current	100 mA
Reverse Voltage	90 V
Operating Temperature	-55 °C to +125 °C
Storage Temperature	-55 °C to +150 °C
Junction Temperature	+ 175 °C
RF C.W. Incident Power	30 dBm C.W.
RF & DC Dissipated Power	150 mW
Mounting Temperature	+235°C for 10 seconds

1. Exceeding these limits may cause permanent damage.

Case Style ODS-1302

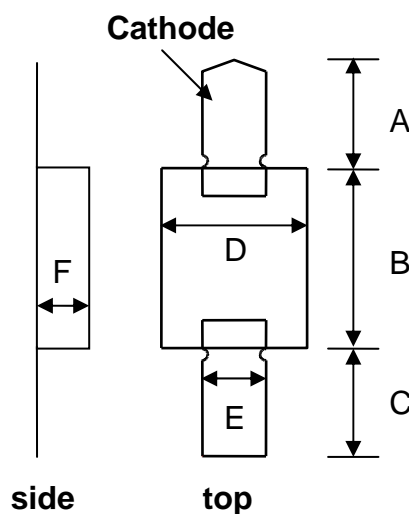

Dimension	Mils	mm
A	9.3 +/- 2.0	0.24 +/- 0.05
B	15.3 +/- 2.0	0.39 +/- 0.05
C	9.3 +/- 2.0	0.24 +/- 0.05
D	12.6 +/- 2.0	0.32 +/- 0.05
E	5.5 +/- 2.0	0.14 +/- 0.05
F	5.0 +/- 1.0	0.13 +/- 0.03

Electrical Specifications at +25°C

Symbol	Conditions	Units	Typ	Max
C_T	0V, 1MHz ²	pF	0.048	
C_T	-3V, 1MHz ²	pF	0.039	
C_T	-10V, 1MHz ²	pF	0.033	0.040
C_T	-40V, 1MHz ²	pF	0.030	0.040
C_T	0V, 100MHz ^{2,4}	pF	0.043	
C_T	-3V, 100MHz ^{2,4}	pF	0.033	
C_T	-10V, 100MHz ^{2,4}	pF	0.031	
C_T	-40V, 100MHz ^{2,4}	pF	0.027	
C_T	0V, 1GHz ^{2,4}	pF	0.039	
C_T	-3V, 1GHz ^{2,4}	pF	0.032	
C_T	-10V, 1GHz ^{2,4}	pF	0.029	
C_T	-40V, 1GHz ^{2,4}	pF	0.026	
R_S	10mA, 100 MHz ^{3,4}	Ω	3.8	
R_S	20mA, 100 MHz ^{3,4}	Ω	3.0	
R_S	10mA, 1GHz ^{3,4}	Ω	3.5	
R_S	20mA, 1GHz ^{3,4}	Ω	2.8	
V_F	20mA	V	0.917	1.1
V_R	-10 μ A	V	110	
I_R	-40 V	nA	1.0	
I_R	-90 V	μ A	-	10.0
TL	+10mA / -6mA	ns	110	

Notes:

- Total capacitance, C_T , is equivalent to the sum of Junction Capacitance, C_j , and Parasitic Capacitance, C_{par} .
- Series resistance R_S is equivalent to the total diode resistance :
 $R_S = R_j$ (Junction Resistance) + R_c (Ohmic Resistance)
- R_S and C_T are measured on an HP4291A Impedance Analyzer with die mounted in an ODS-186 package with conductive silver epoxy.

Die Handling

All semiconductor chips should be handled with care to avoid damage or contamination from perspiration and skin oils. The use of plastic tipped tweezers or vacuum pickups is strongly recommended for individual components. Bulk handling should insure that abrasion and mechanical shock are minimized.

Die Bonding

These devices were designed to be inserted onto hard or soft substrates. Recommended methods of attachment include thermocompression bonding, parallel-gap welding, and electrically conductive silver epoxy.

See Application Note M541, “Bonding and Handling Procedures for Chip Diode Devices” for More Detailed Assembly Instructions.

Typical Performance Curves @ +25°C

Total Capacitance C_t vs V

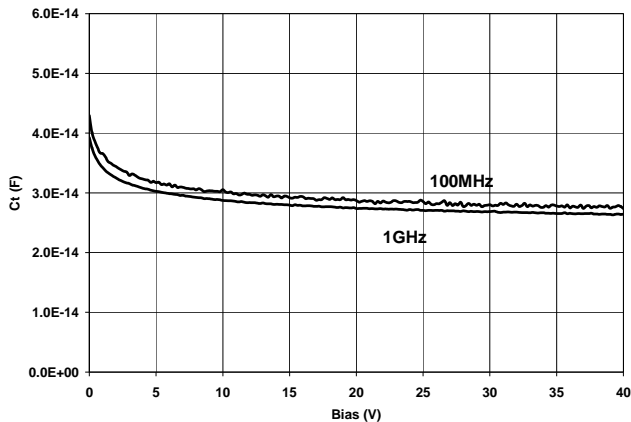

Total Capacitance C_t vs Freq

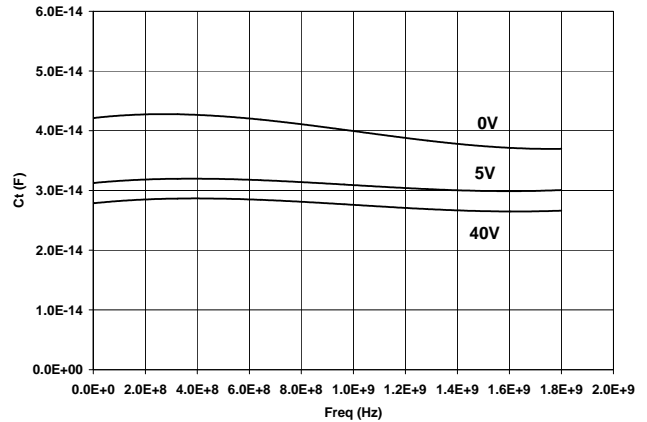

Parallel Resistance R_p vs V

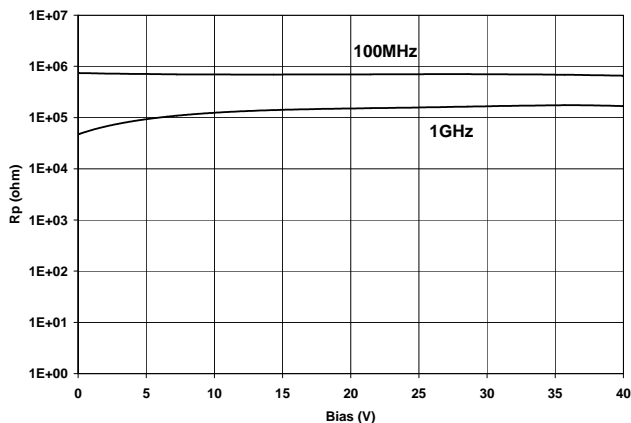

Series Resistance R_s vs F

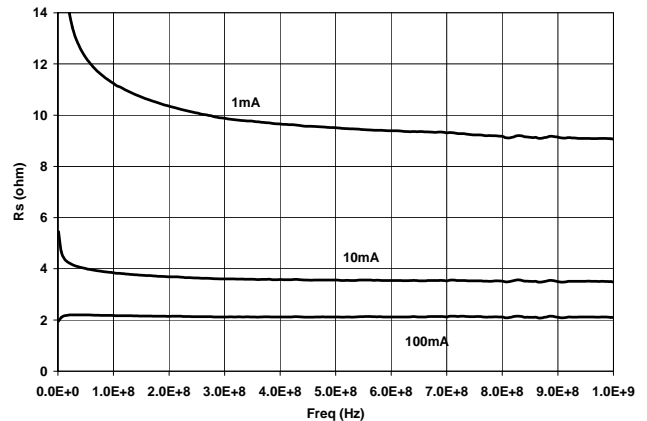

Series Resistance R_s vs I

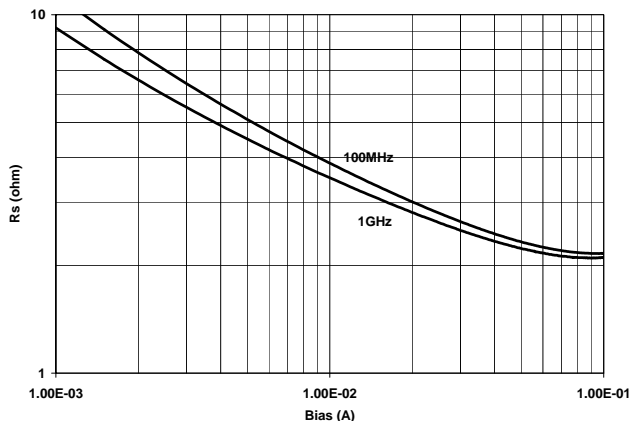

Series Inductance L_s vs Freq

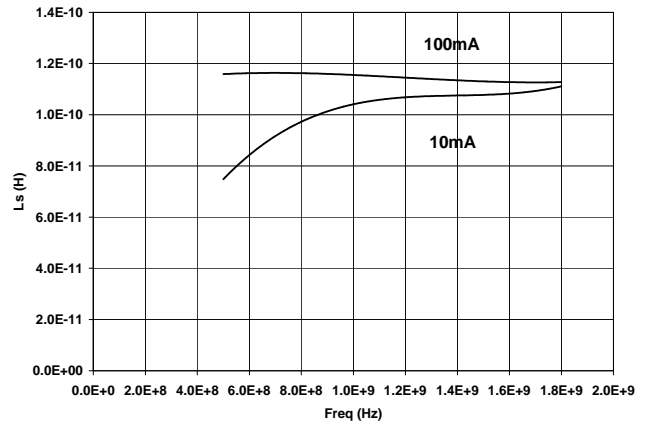

ADVANCED: Data Sheets contain information regarding a product M/A-COM Technology Solutions is considering for development. Performance is based on target specifications, simulated results, and/or prototype measurements. Commitment to develop is not guaranteed.

PRELIMINARY: Data Sheets contain information regarding a product M/A-COM Technology Solutions has under development. Performance is based on engineering tests. Specifications are typical. Mechanical outline has been fixed. Engineering samples and/or test data may be available. Commitment to produce in volume is not guaranteed.

• **North America** Tel: 800.366.2266 • **Europe** Tel: +353.21.244.6400
 • **India** Tel: +91.80.43537383 • **China** Tel: +86.21.2407.1588
 Visit www.macomtech.com for additional data sheets and product information.

M/A-COM Technology Solutions Inc. and its affiliates reserve the right to make changes to the product(s) or information contained herein without notice.

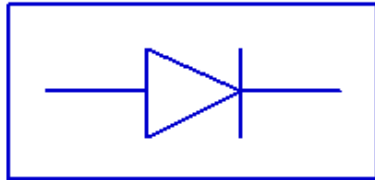

MA4PBL027 SPICE Model

PinDiodeModel

NLPINM1

Is=1.0E-14 A

Vi=0.0 V

Un= 900 cm²/V-sec

Wi= 14 um

Rr= 100 K Ohms

Cjmin= 0.03 pF

Tau= 110 nsec

Rs(l)= Rc + Rj(l) = 0.05 Ohm + Rj(l)

Cj0= 0.04 pF

Vj= 0.7 V

M= 0.5

Fc= 0.5

Imax= 1.1E+5 A/m²

Kf=0.0

Af=1.0

wBv= 90 V

wPmax= 150 mW

Ffe= 1.0

AllParams=

MA4PBL027 Microwave Model

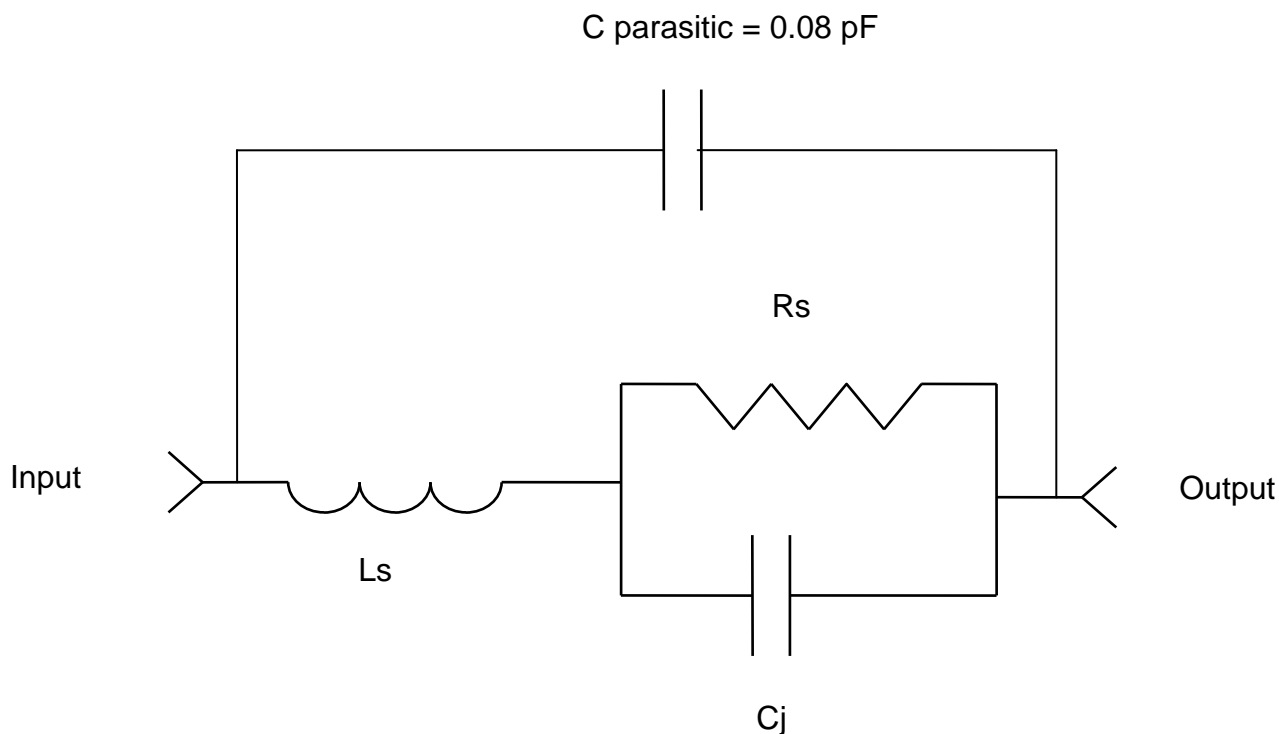

Notes :

$$C_T(V) = C_j(V) + C_{\text{parasitic}} \text{ (Reverse Bias State)}$$

$$R_s(I) = R_j(I) + R_c \text{ (Forward Bias State)}$$

$$R_s(V) = R_j(V) = R_p(V) \text{ (Reverse Bias State)}$$

Компания «Океан Электроники» предлагает заключение долгосрочных отношений при поставках импортных электронных компонентов на взаимовыгодных условиях!

Наши преимущества:

- Поставка оригинальных импортных электронных компонентов напрямую с производств Америки, Европы и Азии, а так же с крупнейших складов мира;
- Широкая линейка поставок активных и пассивных импортных электронных компонентов (более 30 млн. наименований);
- Поставка сложных, дефицитных, либо снятых с производства позиций;
- Оперативные сроки поставки под заказ (от 5 рабочих дней);
- Экспресс доставка в любую точку России;
- Помощь Конструкторского Отдела и консультации квалифицированных инженеров;
- Техническая поддержка проекта, помощь в подборе аналогов, поставка прототипов;
- Поставка электронных компонентов под контролем ВП;
- Система менеджмента качества сертифицирована по Международному стандарту ISO 9001;
- При необходимости вся продукция военного и аэрокосмического назначения проходит испытания и сертификацию в лаборатории (по согласованию с заказчиком);
- Поставка специализированных компонентов военного и аэрокосмического уровня качества (Xilinx, Altera, Analog Devices, Intersil, Interpoint, Microsemi, Actel, Aeroflex, Peregrine, VPT, Syfer, Eurofarad, Texas Instruments, MS Kennedy, Miteq, Cobham, E2V, MA-COM, Hittite, Mini-Circuits, General Dynamics и др.);

Компания «Океан Электроники» является официальным дистрибьютором и эксклюзивным представителем в России одного из крупнейших производителей разъемов военного и аэрокосмического назначения «**JONHON**», а так же официальным дистрибьютором и эксклюзивным представителем в России производителя высокотехнологичных и надежных решений для передачи СВЧ сигналов «**FORSTAR**».



JONHON

«**JONHON**» (основан в 1970 г.)

Разъемы специального, военного и аэрокосмического назначения:

(Применяются в военной, авиационной, аэрокосмической, морской, железнодорожной, горно- и нефтедобывающей отраслях промышленности)

«**FORSTAR**» (основан в 1998 г.)

ВЧ соединители, коаксиальные кабели, кабельные сборки и микроволновые компоненты:

(Применяются в телекоммуникациях гражданского и специального назначения, в средствах связи, РЛС, а так же военной, авиационной и аэрокосмической отраслях промышленности).



Телефон: 8 (812) 309-75-97 (многоканальный)

Факс: 8 (812) 320-03-32

Электронная почта: ocean@oceanchips.ru

Web: <http://oceanchips.ru/>

Адрес: 198099, г. Санкт-Петербург, ул. Калинина, д. 2, корп. 4, лит. А