



Electronic Components

High Quality

CAPACITORS

ALUMINUM ELECTROLYTIC CAPACITORS WITH CONDUCTIVE POLYMER

SOLID ELECTROLYTE

ALUMINUM ELECTROLYTIC CAPACITORS

ELECTRIC DOUBLE LAYER CAPACITORS "DYNACAP®"

PLASTIC FILM CAPACITORS

ELNA CO.,LTD.

CAT.No.2013/2014E

Certifications of Quality Management System (as of Sep. 2012)

Factory	Applicable Standard	Certification Number	Item	Applicable Organization
ELNA CO., LTD. SHIRAKAWA Tech. (Japan)	ISO 9001	JP05/060268	Aluminum electrolytic capacitors Electric double layer capacitors	SGS
ELNA TOHOKU CO., LTD. AOMORI Factory (Japan)				
TANIN ELNA CO., LTD. (Thailand)	ISO/TS 16949	IATF0089622 44 111 060686	Aluminum electrolytic capacitors Electric double layer capacitors	TÜV
	ISO 9001	04100 1999 0506	Aluminum electrolytic capacitors Electric double layer capacitors	TÜV
ELNA-SONIC SDN. BHD. (Malaysia)	ISO/TS 16949	IATF0110000 SGS MY04/0675	Aluminum electrolytic capacitors	SGS
	ISO 9001	SG02/20012	Aluminum electrolytic capacitors	SGS

Certifications of Environmental Management System (as of Sep. 2012)

Factory	Applicable Standard	Certification Number	Applicable Organization
ELNA TOHOKU CO., LTD. AOMORI Factory (Japan)	ISO 14001	JQA-EM2918	Japan Quality Assurance (JQA)
TANIN ELNA CO., LTD. (Thailand)	ISO 14001	04104 1999 0506E5	TÜV
ELNA-SONIC SDN. BHD. (Malaysia)	ISO 14001	SG03/60718	SGS

Please read the following warning and cautions !!

The Electronic components shown in this catalog are designed and produced mainly for such general purpose electronic equipment as audio and visual equipment, home appliances, office equipment and information processing and communication equipment.

If you wish to use these components in medical equipment, transportation equipment, (automotive, train, ships, etc), aircraft, spacecraft, security systems or other equipment that requires high security application, you are required to confirm application through your own testing and own judgment.

Regardless of a component intended use, if high safety application is required, it is recommended that you shall establish a protective or redundant circuit and shall conduct own evaluation test.

It is highly recommended that you shall follow our "Cautions for using"

Also it is recommended that you shall obtain technical specifications from Elna Co., Ltd to ensure that the component is suitable for your intended use.

It is not our responsibility for any kind of problems without technical specifications.

Specifications and dimensions shown in this catalog are subject to change without prior notice.

Be sure to read “Cautions for Using Electrolytic Capacitors”, before using those products.

1	Aluminum Electrolytic Capacitors	5	
	Aluminum Electrolytic Capacitors With Conductive Polymer Solid Electrolyte	21	Aluminum Electrolytic Capacitors With Conductive Polymer Solid Electrolyte
	Chip Type Aluminum Electrolytic Capacitors	49	Chip Type Aluminum Electrolytic Capacitors
	Miniature Aluminum Electrolytic Capacitors	83	Miniature Aluminum Electrolytic Capacitors
	Large Capacitance Aluminum Electrolytic Capacitors	127	Large Capacitance Aluminum Electrolytic Capacitors
	Aluminum Electrolytic Capacitors for Audio	151	Aluminum Electrolytic Capacitors for Audio
2	Electric Double Layer Capacitors “DYNACAP” , “POWERCAP”	177	Electric Double Layer Capacitors

■ “GREEN CAP”

“GREEN CAP”, ELNA considers the global environment and it is a product that doesn't use the hazardous substance and “Lead Free” in the plating of terminals and outer Sleeves.

The product in this catalog is ‘GREEN CAP’ if there is no description in the text.

The hazardous substance is

Pb : lead, Cr⁶⁺ : hexavalent chromium, Hg : mercury and Cd : cadmium,
PBB : the polybrominated biphenyl, PBDE : the polybromo-diphenyl ether,

■ Regarding to various environmental Regulations

- It suits “EU RoHS Directives”.
- According to the content of RIP3.8TGD(Technical Guidance Document which is published on 26 May 2008), our electronic components are “articles without any intended release”.
Therefore they are not applicable for “Registration” for EU REACH Regulation Article 7 (1).
ELNA develops the products without substance of very high concern(SVHC). DEHP(CASNo.117-81-7) was contained as some covering material.
- If you need “Halogen-Free” products, please consult with us.

Terminal area plating material and sleeve material

● Aluminum electrolytic capacitors

Category		Terminal area plating	Plating thickness	Sleeve
SMD (Chip type)	φ3 to 6.3	Sn-Bi	12μm	Sleeve less
	φ8,10	Sn-Bi	12μm	PET or sleeve less
	φ12.5	Sn 100%	12μm	PET or sleeve less
	φ16 to 18	Sn 100%	12μm	Sleeve less
	A supplementary terminal	Sn 100%	12μm	PET or sleeve less
Sn 100%		12μm	Sleeve less	
Lead terminal		Sn 100%	12μm	PET or sleeve less
Snap-in		Sn 100%	12μm	PET
Screw terminal		—		PVC *

* Pb less PVC

● Electric double layer capacitors

Category		Terminal area plating	Plating thickness	Sleeve	
Cion cell	SMD	Single cell	Sn 100% or Sn + Cu	5μm	Sleeve less
		Piled cell	Sn 100%	5μm	PET
	Lead type	Sn 100% or Sn + Cu	5μm	PET	
Large capacitance	Lead terminal		Sn 100%	12μm	PET
	Snap-in terminal		Sn 100%	12μm	PET
	Screw terminal		—		PET

Note : Sn : Tin Bi : Bismuth Cu : Copper

Please inquire when hoping excluding the above-mentioned terminal plating and sleeve.

■ **About the Sn whisker**

1. Sn whisker-generating mechanism on the lead wire

On the surface of the lead wire, Sn and aluminum will get mixed instead of getting dissolved.

The surface condition is complex, aluminum will expand due to the heat and humid causing the oxidation and hydration. This reaction will cause the inner stress and influence the development of the whisker.

2. Generation control of the Sn whisker

In the past, Sn whisker was reduced by adding a lead(Pb). Aluminum electrolytic capacitor was also using the Sn-plate with Pb on the lead wire.

But due to environmental regulation such as the “ELV” and “RoHS”, Pb was strictly prohibited since 2000.

Lead wire not containing the Pb was used, which caused the Sn whisker problem to happen again.

Since Sn whisker is influenced by the mixture of aluminum, method of reducing the aluminum on the welding surface was to clean the lead terminal using the alkali.

However since the welding area of the large case size is larger compared to the small ones, whisker will generate even if it is cleaned by alkali. This whisker will scatter outside of the capacitor and potentially cause the short-circuit. Countermeasure of keeping the whisker inside the capacitor is being discussed.

3. Prevention of scattering of Sn whisker

In the past Sn-plate with Pb was used and recently plate with Bi is being introduced to prevent the whisker from generating. However the whisker will still generate under the temperature and moisture condition.

Therefore, the current method of preventing the whisker will not completely prevent the whisker from generating.

In our company, we are developing and supplying products with design of preventing the whisker from scattering outside the capacitor.

This design corresponds to series such as the RJD and RJE for 105°C use, RKD and RPK for 125°C use.

If it is required for the other series, please feel free to make an inquiry.

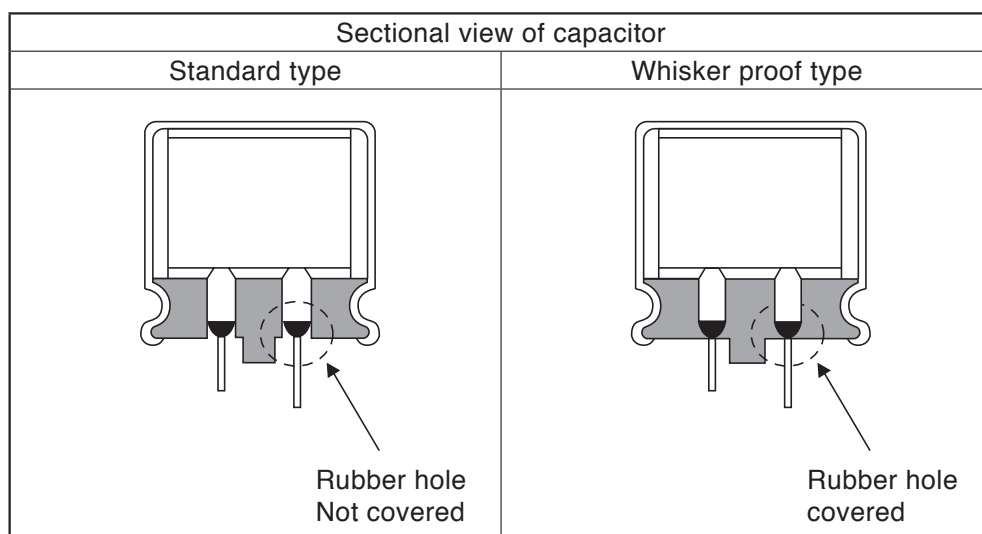

Ordering Information

Please designate the number of capacitors you order in integral multiples of the minimum packing number of units.

Aluminum Electrolytic Capacitors

Classification		Size φD×L (mm)	Quantity (PCS.)							
			Long lead		Forming lead		Taping (flat box)		Taping (reel)	
			Vinyl bag	Packaging box	Vinyl bag	Packaging box	Box	Packaging quantity	One reel	Packaging quantity
Aluminum Electrolytic Capacitors With Conductive Polymer Solid Electrolyte	Chip Type	φ5 to φ6.3×4.5 to 7.7	—	—	—	—	—	—	1,000	5,000
		φ8×6.7 to 7.7	—	—	—	—	—	—	1,000	4,000
		φ10×7.7	—	—	—	—	—	—	500	2,000
	04 Type	φ6.3×8	200	2,000	200	2,000	2,000	20,000	—	—
		φ8×8	200	2,000	200	2,000	1,000	10,000	—	—
φ10×12.5		200	1,000	200	1,000	500	5,000	—	—	
Chip Type	φ3, φ4	—	—	—	—	—	—	2,000	10,000	
	φ5 to φ8×6.7, φ6.3×7.7	—	—	—	—	—	—	1,000	5,000	
	φ8×10, φ10×10 to 10.5	—	—	—	—	—	—	500	2,000	
	φ12.5×13.5	—	—	—	—	—	—	200	1,000	
	9.5×19 to 24	—	—	—	—	—	—	400	(2,000)	
04 Type	φ3 to φ5×5, φ4×7	200	2,000	200	5,000	2,000	20,000	—	—	
	φ5×7	200	2,000	200	4,000	2,000	20,000	—	—	
	φ6.3×5, φ6.3×7	200	2,000	200	2,000	2,000	20,000	—	—	
	φ8×5 to 7	200	2,000	200	2,000	1,000	10,000	—	—	
	φ5 to 6.3×11, 11.5, 15	200	2,000	200	2,000	2,000	20,000	—	—	
	φ8×11.5,12	200	2,000	200	2,000	1,000	10,000	—	—	
	φ8×15	200	1,000	200	2,000	1,000	8,000	—	—	
	φ8×20	200	1,000	200	1,000	1,000	8,000	—	—	
	φ10×12.5	200	1,000	200	4,000	500	5,000	—	—	
	φ10×16	200	1,000	200	1,000	500	5,000	—	—	
	φ10×20	200	1,000	100	500	500	4,000	—	—	
	φ10×25 to 30	200	1,000	100	500	500	3,000	—	—	
	φ12.5×15	100	1,000	100	500	500	4,000	—	—	
	φ12.5×20 to 25	100	500	100	1,000	500	4,000	—	—	
	φ12.5×30 to 35	100	500	200	2,000	500	3,000	—	—	
	φ12.5×40	100	500	200	2,000	—	—	—	—	
	φ16×16 to 20	100	500	100	1,000	250	2,000	—	—	
	φ16×25	100	500	100	1,000	250	1,500	—	—	
	φ16×31.5 to 35.5	50	200	100	1,000	250	1,500	—	—	
	φ16×40	50	100	100	800	—	—	—	—	
φ18×16 to 31.5	50	100	100	1,000	250	1,500	—	—		
φ18×35.5	50	100	100	1,000	—	—	—	—		
φ18×40	50	250	100	800	—	—	—	—		
69□Type	φ22 to φ25	—	100	—	—	—	—	—	—	
331Type or Others	φ30 to φ35	—	50	—	—	—	—	—	—	
	φ36 to φ101	—	*	—	—	—	—	—	—	

* Please inquire.

Electric Double Layer Capacitors

Series		Case size (mm)	Quantity (PCS.)							
			Long lead		Standard lead		Taping (flat box)		Taping (reel)	
			Vinyl bag	Packaging box	Vinyl bag	Packaging box	Box	Packaging quantity	One reel	Packaging quantity
DX, DXJ, DXN, DXS (H or V Terminal)	φ11.5	—	—	200	8,000	—	—	—	—	
DX, DXJ, DXN (V Terminal)	φ19	—	—	100	2,000	—	—	—	—	
DH, DHL, DHC, DBJ	φ13.5	—	—	200	4,000	—	—	—	—	
DK, DB, DBN, DBS	φ21.5	—	—	100	2,000	—	—	—	—	
DC, DCK	φ6.8	—	—	200	6,000	—	—	—	—	
DS, DSK	φ4.8	—	—	—	—	—	—	2,000	10,000	
	φ6.8	—	—	—	—	—	—	1,500 to 2,000*	6,000 to 10,000*	
DVN	φ12.5×8.5	—	—	—	—	—	—	300	1,500	
DVL	φ12.5×10.5	—	—	—	—	—	—	250	1,250	
Series		Case size (mm)	Quantity (PCS.)							
			Long lead		Forming lead		Taping (flat box)		Taping (reel)	
			Vinyl bag	Packaging box	Vinyl bag	Packaging box	Box	Packaging quantity	One reel	Packaging quantity
DY	φ6.3	200	1,000	200	2,000	2,000	20,000	—	—	
	φ8	200	1,000	200	1,000	1,000	8,000	—	—	
	φ10	200	1,000	100	500	500	3,000	—	—	
DZ	φ12.5×23	100	500	100	1,000	500	4,000	—	—	
	φ12.5×31.5	100	500	200	2,000	500	3,000	—	—	
DZN	φ16×20	100	500	100	1,000	250	2,000	—	—	
	φ16×25	100	500	100	1,000	250	1,500	—	—	
DZH	φ16×31.5 to 35.5	50	200	100	1,000	250	1,500	—	—	
	φ18	50	250	100	800	—	—	—	—	
	φ25	—	50 or 100*	—	—	—	—	—	—	
	φ35	—	50 or 100*	—	—	—	—	—	—	
DP	φ35	—	50	—	—	—	—	—	—	
	φ51	—	32	—	—	—	—	—	—	
DZP	8.5×17×16 8.5×17×24 10.5×21×34 10.5×21×39	—	*	—	—	—	—	—	—	

* Please inquire.



Aluminum Electrolytic Capacitors

List of Contents

1. Type List for Aluminum Electrolytic Capacitors	6
2. Systematized Classification of Aluminum Electrolytic Capacitors	8
3. Product Symbol System for Aluminum Electrolytic Capacitors	10
4. Recommended Land Pattern and Size, for Chip Type	11
5. Recommended Soldering Conditions	12
6. Recommended Taping for Chip Type	14
7. Lead Forming and Taping for Lead Type	15
8. Cautions for Using Aluminum Electrolytic Capacitors With Conductive Polymer Solid Electrolyte	22
9. Specifications for Aluminum Electrolytic Capacitors With Conductive Polymer Solid Electrolyte by Series	26
10. Cautions for Using Aluminum Electrolytic Capacitors	44
11. Specifications for Chip Type Aluminum Electrolytic Capacitors by Series	49
12. Specifications for Miniature Aluminum Electrolytic Capacitors by Series	83
13. Specifications for Large Aluminum Electrolytic Capacitors by Series	127
14. Specifications for Aluminum Electrolytic Capacitors for Audio by series	151
15. Technical Notes on Aluminum Electrolytic Capacitors	168



■ Type List for Miniature and Chip Type Aluminum Electrolytic Capacitors

○ : Apply to those capacitors with rated voltage of 250V or less.

★ : New series

☆ : Upgrade

Category	Series	Page	Applications	Thin and small Size	Feature						Category Temp. Range °C		Rated Voltage Range V.DC		Rated capacitance Range μF		Color of sleeve	JIS Configuration	Note		
					Reliability at 105°C					For Audio	Anti-cleaning solvent	Reflow Soldering Resistance	Max.	Min.	Max.	Min.				Max.	Min.
					1000hrs	2000hrs	3000hrs	5000hrs	10000hrs												
Polymer	PVG	26	Ultra Low ESR Conductive Polymer Chip		•					•	•	+ 105	- 55	6.3	2.5	120 to 1200	Silver	32	☆		
	PVX	28	Ultra Low ESR Conductive Polymer Chip		•					•	•	+ 105	- 55	10	2.5	100 to 1200	Silver	32	☆		
	PV2	30	Super Low ESR Conductive Polymer Chip, 4.5mmL	•	•					•	•	+ 105	- 55	25	2.5	15 to 390	Silver	32			
	PVM	32	Super Low ESR Conductive Polymer Chip		•					•	•	+ 105	- 55	35	2.5	10 to 1200	Silver	32	☆		
	PVH	34	Low ESR Conductive Polymer Chip		•					•	•	+ 105	- 55	35	2.5	10 to 1000	Silver	32	☆		
	PVK	36	Super Low ESR, High Temp. Conductive Polymer Chip			•				•	•	+ 125	- 55	25	2.5	10 to 1000	Silver	32	★		
	PVS	38	Super Low ESR, High Voltage Conductive Polymer Chip		•					•	•	+ 105	- 55	63	35	18 to 100	Silver	32	★		
	PRM	40	Super Low ESR Conductive Polymer		•					•		+ 105	- 55	10	2.5	10 to 1500	Silver	04	★		
Surface Mounting Type	RV2	50	5.5mm L	•						•	•	+ 85	- 40	50	4	0.22 to 220	Silver	32			
	RV	51	Higher Capacitance Range							•	•	+ 85	- 40	100	6.3	10 to 2200	Silver Brown	32			
	RV3	52	High CV	•						•	•	+ 85	- 40	50	6.3	4.7 to 330	Silver	32			
	RV4	53	4.5mm L	•						•	•	+ 85	- 40	50	6.3	0.22 to 100	Silver	32			
	RV5	54	High CV	•						•	•	+ 85	- 40	100	6.3	2.2 to 1500	Silver Brown	32			
	RVB	56	Non Polarized	•						•	•	+ 85	- 40	50	6.3	0.22 to 47	Silver	32			
	RVE	57	105°C, 4.5mmL	•	•					•	•	+ 105	- 40	50	6.3	0.22 to 100	Silver	32			
	RVS	58	105°C, 5.5mm L	•	•					•	•	+ 105	- 55	50	6.3	0.22 to 1500	Silver	32	☆		
	RVL	60	Long Life, 105°C, 6.0mm L	•	•					•	•	+ 105	- 55	50	6.3	0.22 to 100	Silver	32			
	RVR	62	105°C, Long Life, High CV	•	•					•	•	+ 105	- 40	50	4	0.22 to 1500	Silver	32	☆		
	RVJ	61	105°C, Higher Capacitance		•					•	•	+ 105	- 55	100	6.3	10 to 1000	Silver Brown	32			
	RVC	64	105°C, 3000h/5000h			•	•			•	•	+ 105	- 40	50	6.3	0.22 to 1000	Silver	32			
	RVD	66	105°C, 3000h/5000h		•	•		•		•	•	+ 105	- 55	100	6.3	4.7 to 1500	Silver	32	☆		
	RVV	68	105°C, Low Impedance, Long life		•			•		•	•	+ 105	- 55	35	6.3	4.7 to 1500	Silver	32	★		
	RVZ	70	105°C, Low Impedance		•			•		•	•	+ 105	- 55	35	6.3	4.7 to 2700	Silver Brown	32			
	RVT	72	125°C, Low ESR	•			•			•	•	+ 125	- 40	100	10	4.7 to 470	Silver	32	☆		
	RVK	74	125°C, Higher Reliability				•			•	•	+ 125	- 40	63	10	10 to 1000	Brown	32	☆		
	RVX	75	135°C, Higher Reliability				•	•		•	•	+ 135	- 40	35	25	22 to 330	Silver	32	★		
	RVI	76	105°C, Non Polarized, 2000h	•	•					•	•	+ 105	- 40	50	6.3	0.22 to 47	Silver	32			
	RTJ	77	105°C, Higher Capacitance, Vibration resistance		•					•	•	+ 105	- 55	100	6.3	10 to 470	Brown	32			
RTK	78	125°C, Vibration resistance				•			•	•	+ 125	- 40	63	10	10 to 330	Brown	32	☆			
RTZ	79	105°C, Low Z, Higher Capacitance, Vibration resistance		•	•				•	•	+ 105	- 55	35	6.3	150 to 8200	Silver	32	★			
RTD	80	105°C, Low Z, Higher Capacitance, Vibration resistance				•			•	•	+ 105	- 55	100	6.3	100 to 8200	Silver	32	★			
RTT	81	125°C, Low ESR, Higher Capacitance, Vibration resistance				•	•		•	•	+ 125	- 40	100	10	100 to 4700	Silver	32	★			
RYK	82	125°C, Horizontal type			•				•	•	+ 125	- 40	63	6.3	56 to 820	Black	88				
Ultra-miniature Type	RC3	84	5mm L, Standard	•							+ 85	- 40	50	4	0.22 to 470	Black Blue	04				
	R3S	85	5mm L, 105°C	•	•					•		+ 105	- 55	50	6.3	0.22 to 100	Black	04			
	RB3	86	5mm L, Bipolar	•								+ 85	- 40	50	6.3	0.22 to 47	Blue	04			
	RC2	87	7mm L, Standard	•						•		+ 85	- 40	100	4	0.33 to 330	Blue	04			
	R2S	88	7mm L, 105°C	•	•					•		+ 105	- 55	50	6.3	0.33 to 100	Black	04			
	RB2	89	7mm L, Bipolar	•						•		+ 85	- 40	50	6.3	0.22 to 47	Blue	04			
Standard Type	RE3	90	Miniaturized Standard	•						○		+ 85	- 40	450	6.3	1 to 22000	Blue	04			
	R2B	92	Bipolarity Standard							•		+ 85	- 40	100	6.3	0.47 to 4700	Blue	04			
	RJP	93	105°C, Bipolar		•					•		+ 105	- 40	50	6.3	0.47 to 6800	Black	04	★		
	RJ5	94	105°C, Miniaturized, High CV	•	•					•		+ 105	- 40	450	6.3	1 to 22000	Black	04	☆		
	RJ4	96	105°C, Miniaturized		•	•					○		+ 105	- 55	100	6.3	1 to 22000	Black	04		
														+ 105	- 40	450	160	0.47 to 330		Black	
RJ3	98	105°C, Low Impedance		•						○		+ 105	- 55	100	6.3	1 to 15000	Black	04			
													+ 105	- 40	400	160	0.47 to 220		Black		
Special Type	RLB	126	Low-leakage Current								+ 85	- 40	50	6.3	1 to 2200	Blue	04				

Type List for Miniature and Large type Aluminum Electrolytic Capacitors

★ : New series
☆ : Upgrade

Category	Series	Page	Applications	Thin and small Size	Feature					Category Temp. Range °C	Rated Voltage Range V.DC		Rated capacitance Range μF	Color of sleeve	JIS Configuration	Note				
					Reliability at 105°C						Low Impedance	For Audio					Anti-cleaning solvent	Rework Soldering Resistance	Max.	Min.
					1000hrs	2000hrs	3000hrs	5000hrs	10000hrs											
High Reliability Type	RJB	100	105°C , Low Impedance, Miniaturized				•	•	•	+ 105	- 55	100	6.3	3.3 to 10000	Black	04				
	RJH	102	105°C , Extra Low Impedance				•	•	•	+ 105	- 55	100	6.3	1 to 15000	Black	04				
	RJF	105	105°C , Extra Low Impedance, Miniaturized				•	•	•	+ 105	- 40	100	6.3	5.6 to 6800	Black	04				
	RJL	108	105°C , Long life, Low Impedance	•			•	•	•	+ 105	- 40	100	6.3	6.8 to 6800	Black	04				
	RJD	110	105°C , Low Impedance, High Ripple, Miniaturized	•			•	•	•	+ 105	- 55	35	6.3	10 to 18000	Black	04	☆			
	RJE	113	105°C , Low Impedance, High Ripple, For Airbag	•			•	•	•	+ 105	- 55	35	25	830 to 11000	Black	04	☆			
	RHS	114	105°C , Long Life, High Ripple, For Ballast	•			•			+ 105	- 40	250	160	4.7 to 220	Black	04	☆			
										+ 105	- 25	450	350	1 to 120	Black					
	RHC	116	105°C , Long Life, High Ripple, For Ballast	•			•			+ 105	- 25	450	160	1 to 270	Black	04	☆			
	RHD	118	105°C , Long Life, High Ripple, For Ballast	•			•			+ 105	- 25	450	160	3.3 to 330	Black	04	☆			
	RKD	120	125°C , Low Impedance, Miniaturized	•			•	•	•	+ 125	- 40	100	10	100 to 6800	Black	04	☆			
	RPK	122	125°C , Low Impedance, Vibration resistance	•			•	•	•	+ 125	- 40	100	10	220 to 6800	Black	04	★			
	RQA	124	150°C , Low Impedance, Miniaturized	•			•	•	•	+ 150	- 40	35	10	220 to 10000	Silver	04	★			
RKB	125	135°C , Low Impedance, Miniaturized	•			•	•	•	+ 135	- 40	35	10	220 to 6800	Silver	04	★				
Snap-in Type	LA5	128	Miniaturized	•					+ 85	- 40	400	10	56 to 82000	Black	692	☆				
									+ 85	- 25	450	-	47 to 470							
	LAT	130	105°C , Miniaturized	•	•					+ 105	- 25	450	160	22 to 2700	Black	692	☆			
	LAH	132	105°C , Standard	•	•					+ 105	- 40	100	16	560 to 47000	Black	692	☆			
										+ 105	- 25	450	160	56 to 2200						
	LAZ	134	High-Reliability, High Ripple, Long Life	•		•				+ 105	- 25	100	16	560 to 47000	Black	692	☆			
											450	160	56 to 2700							
LAX	136	105°C , Ultra Long Life				•			+ 105	- 25	400	160	56 to 1800	Black	692	☆				
LJ6	138	105°C , Higher Capacitance, Ultra Long Life				•			+ 105	- 25	500	200	390 to 3900	Black	-	★				
LJ2	138	105°C , Higher Capacitance, Ultra Long Life				•			+ 105	- 25	500	200	560 to 3900	Black	-	★				
Special Type	LPM	140	High ripple current						+ 85	- 25	400	250	45 to 220	Black	692	★				
	LM	140	High ripple current, Higher Capacitance						+ 85	- 25	400	250	90 to 440	Black	622	★				
Screw terminal Type	LYX	142	105°C , Ultra Long Life				•		+ 105	- 25	450	350	1000 to 15000	Black	331	★				
	LYL	144	Ultra Long Life						+ 85	- 40	450	350	1000 to 15000	Black	331	★				
	LY6	146	High Ripple, Miniaturized	•					+ 85	- 25	550	400	1000 to 22000	Black	331	★				
	LY5	148	Standard						+ 85	- 40	250	10	1500 to 820000	Black	331	★				
								+ 85	- 25	500	350	470 to 18000								
For Audio	RVO	152	Chip Type (PURECAP)	•					+ 85	- 40	50	6.3	0.22 to 1000	Silver Brown	32					
	RVF	153	Chip Type (SILMIC)	•					+ 85	- 40	50	10	0.33 to 100	Silver	32					
	RVM	154	Chip Type 105°C , 2000h	•	•				+ 105	- 55	50	6.3	1 to 470	Silver	32					
	RVW	155	Chip Type 105°C (PURECAP)	•	•				+ 105	- 55	50	6.3	0.22 to 1000	Silver Brown	32					
	RVG	156	Chip Type	•					+ 85	- 40	35	6.3	3.3 to 470	Silver	32					
	RFS	157	High Grade (SILMIC II)						+ 85	- 55	100	6.3	2.2 to 3300	Brown	04					
	ROS	158	High Grade (SILMIC)						+ 85	- 40	100	16	1 to 2200	Brown	04					
	ROB	159	Miniaturized Standard (TONEREX)						+ 85	- 40	100	6.3	1 to 10000	Black	04					
	R2A	160	7mmL	•					+ 85	- 40	50	6.3	0.33 to 330	Black	04					
	R3A	161	5mmL	•					+ 85	- 40	50	4	0.22 to 220	Raddish purple	04					
	RFO	162	Standard (PURECAP)	•					+ 85	- 40	100	6.3	1 to 15000	Black	04					
	RA3	163	Miniaturized Standard	•					+ 85	- 40	100	6.3	1 to 22000	Brown	04					
	RW5	164	105°C , Miniaturized	•	•				+ 105	- 55	25	16	100 to 15000	Black	04	☆				
	RBD	165	Miniaturized Bipolar	•					+ 85	- 40	100	6.3	0.47 to 4700	Black	04					
LAO	166	For Audio, Higher Capacitance						+ 85	- 40	100	16	680 to 10000	Black	692	☆					

* Be sure to "Cautions for Using Aluminum Electrolytic Capacitors", before using these products.

Some series of the following table was omitted from this catalog. Please consult, when you inquire newly.

Category	Series	JIS Configuration	Applications
High Reliability Type	RJJ	04	105°C , Low Impedance
	RK	04	125°C , Longevity
Snap-in Type	LH7	692	Higher Capacitance
	LAV	692	105°C , Compatible with VDE
	LUH	-	105°C , Durable against Over Voltage
For Audio	PVO	32	For Audio, Conductive Polymer Chip
	ROA	04	High Grade (Cerafine)

NOTE

Design, Specifications are subject to change without notice. Ask factory for technical specifications before purchase and/or use.

Systematized Classification of Miniature and Chip Type Aluminum Electrolytic Capacitors

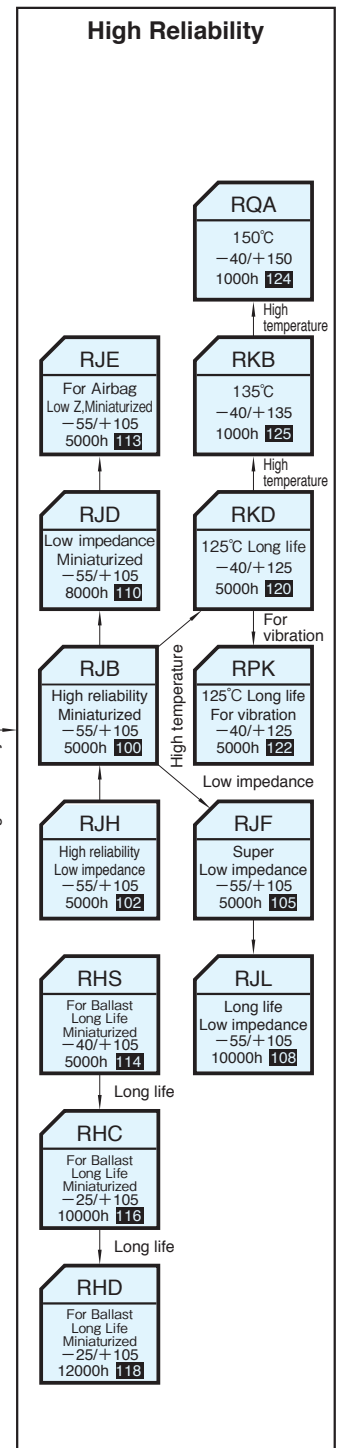
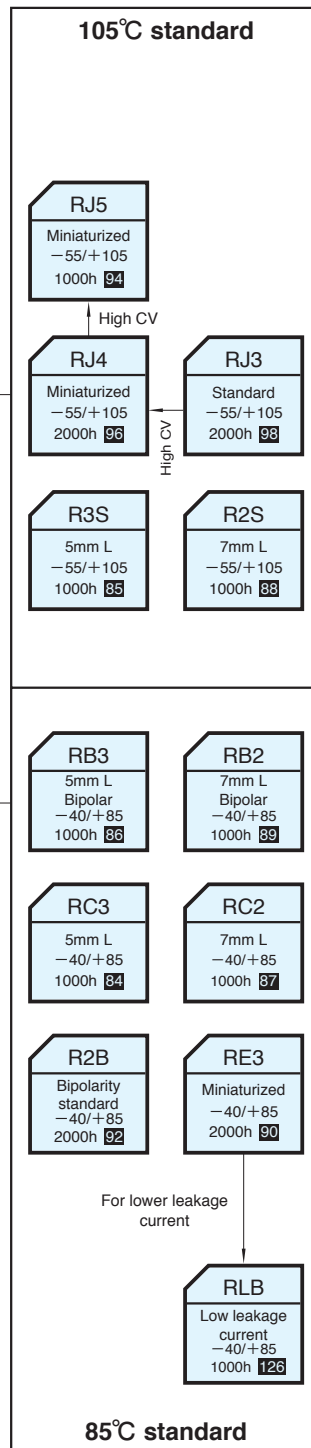
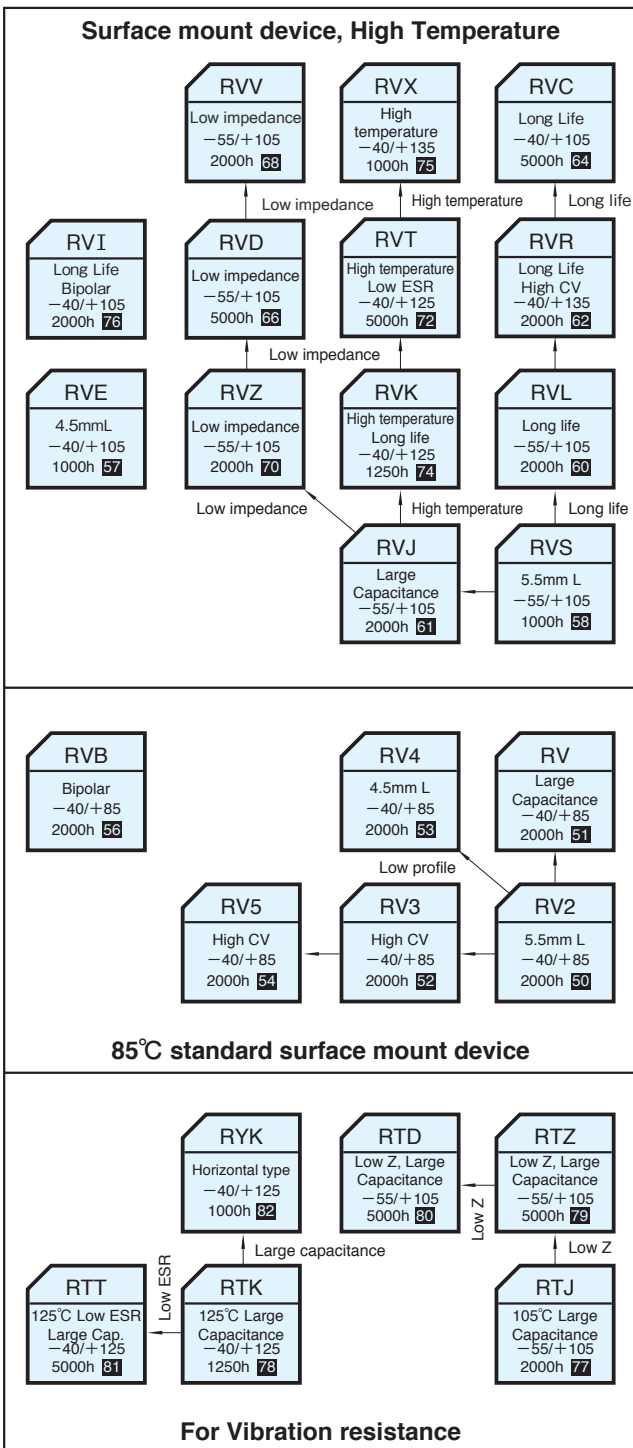
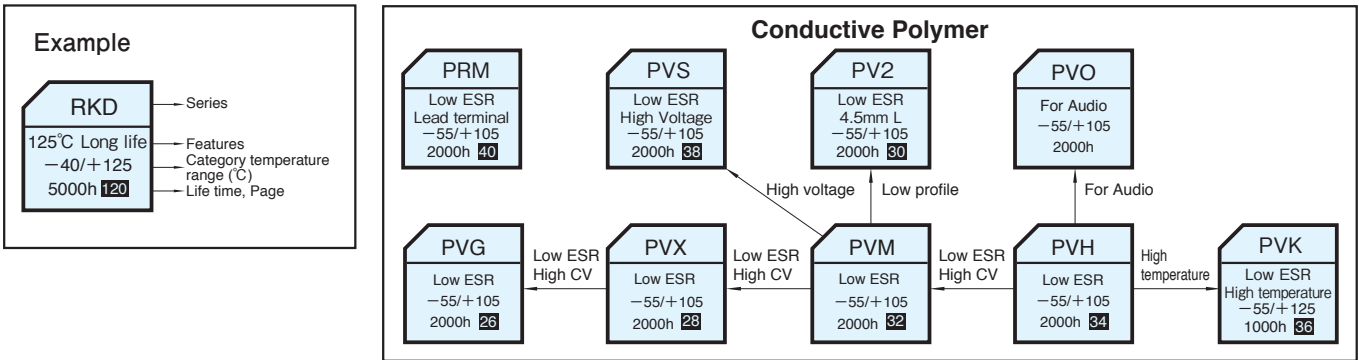

Systematized Classification of Large Aluminum Electrolytic Capacitors

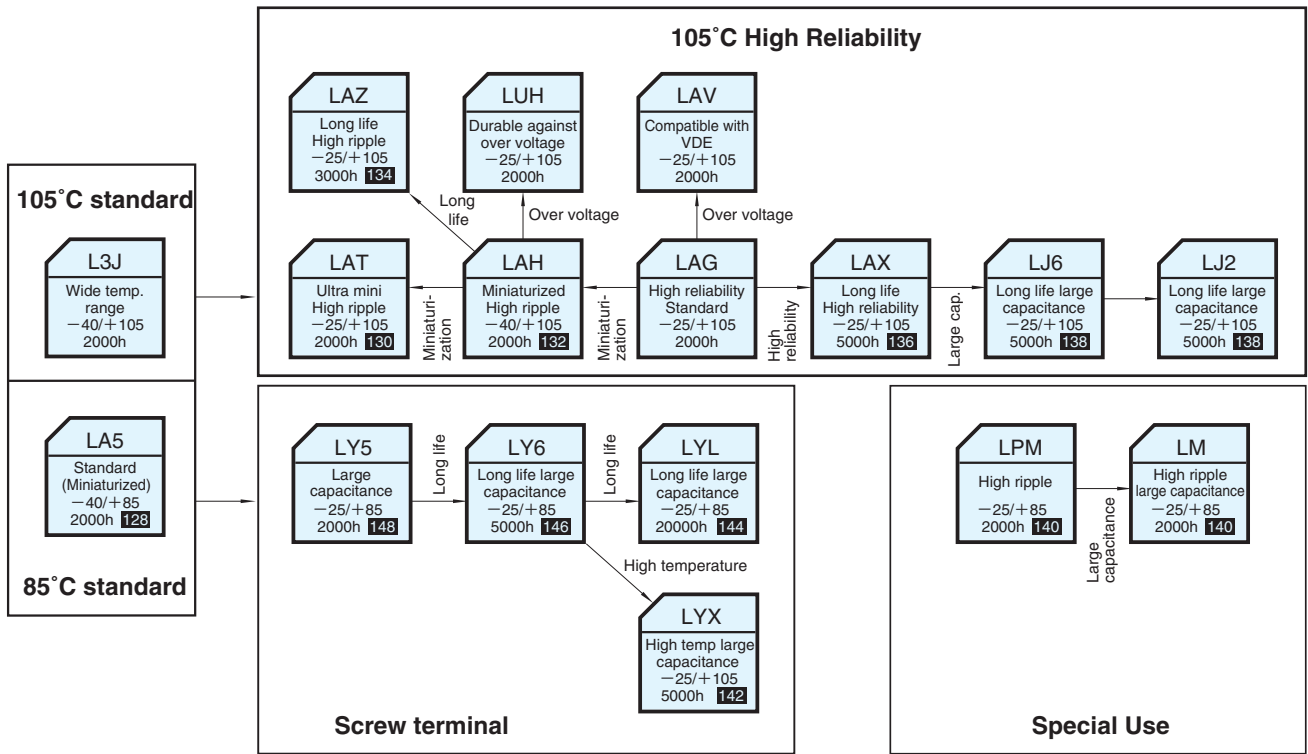

Systematized Classification of Aluminum Electrolytic Capacitors For Audio

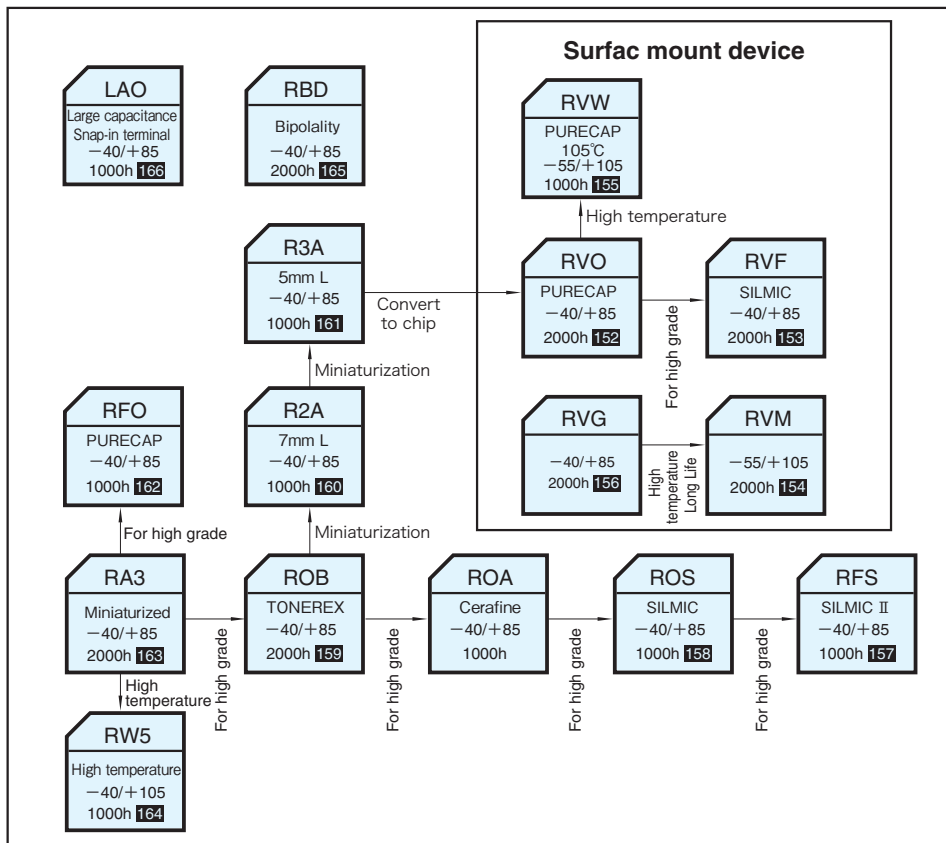

■ Product Symbol System for Aluminum Electrolytic Capacitors

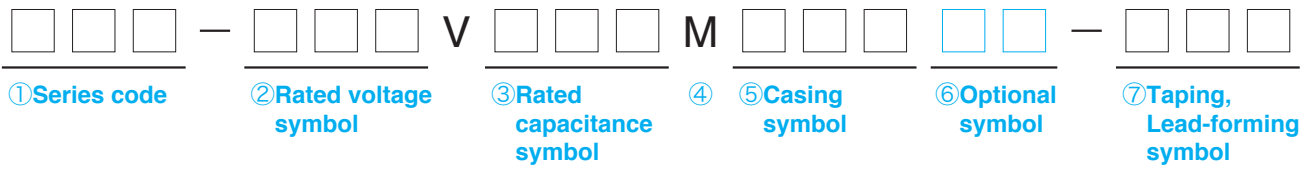

① Series code

Please refer to the page of each series.

② Rated voltage symbol

Write down the rated voltage itself ; however, write 2R5 for 2.5V, 6 for 6.3V.

③ Rated capacitance symbol

The symbol denoting nominal capacitance shall consist of three numerals.
 The first and second numerals shall represent the significant figures of nominal capacitance in the unit of microfarad (μF).
 And the third numeral shall represent the number of zeros following the significant figures.
 A decimal point is expressed with "R."

Example

Rated capacitance (μF)	Symbol
0.1	R10
1	010
2.2	2R2
33	330
100	101
2200	222
33000	333
470000	474

④ Capacitance tolerance symbol

Example

Capacitance tolerance	Symbol
$\pm 10\%$	K
$\pm 20\%$	M
-10 to +30%	Q
-10 to +50%	T

⑤ Casing symbol

Please refer to the page of each series.

⑥ Optional symbol

Plating or others are expressed.

Example

Symbol	Contents
#	Sn 100% plating +PET sleeve (lead terminal type)
U	Sn-Bi plating (chip type)
T	Sn 100% plating (chip type)
Q	Based on AEC-Q200

⑦ Taping, Lead-forming symbol

Write down one of the forming symbols given on page 14 to 17 for taping and lead-forming capacitors.
 When taping or lead-forming is not necessary, leave the boxes blank.

Recommended land pattern and size

(Vertical chip type)

● Standard type

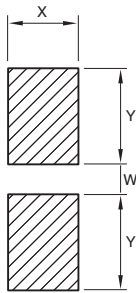

(Unit : mm)

Case Size φD×L	Land Size			Thickness of Solder paste
	X	Y	W	
3×5.3	1.6	2.2	0.8	0.15
4×4.5, 5.3, 5.7, 5.8	1.6	2.6	1.0	0.15
5×4.5, 5.3, 5.7, 5.8	1.6	3.0	1.4	0.15
6.3×4.5, 5.3, 5.7, 5.8	1.6	3.6	1.9	0.15
6.3×7.7	1.6	3.6	1.9	0.15
8×6.5, 6.7	1.6	4.0	2.1	0.15
8×10, 10.5	2.5	*3.5	*3.0	0.15
10×7.7, 10, 10.5	2.5	*4.0	*4.0	0.15
12.5×13.5	3.2	6.0	4.0	0.15

* For Vibration resistance use
 φ8×6.5 Y=4.5 W=1.0
 φ8×10, φ8×10.5 Y=4.0 W=2.5
 φ10×10, φ10×10.5 Y=4.5 W=3.0

● For vibration resistance type

RTJ, RTK series

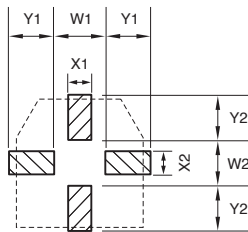

(Unit : mm)

Case Size φD×L	Land Size						Thickness of Solder paste
	X1	X2	Y1	Y2	W1	W2	
8×10	2.5	2.5	3.0	3.5	4.0	3.0	0.20
10×10.5	2.5	2.5	4.0	4.5	4.0	3.0	0.20

RTZ, RTD, RTT series

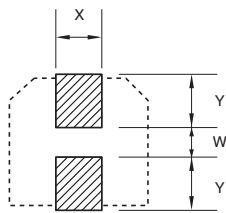

(Unit : mm)

Case Size φD	Land Size			Thickness of Solder paste
	Y	W	X	
8	4.0	2.5	5.0	0.2
10	4.8	3.6	5.0	0.2
12.5	6.6	3.2	7.0	0.2
16	7.8	5.0	10.5	0.2
18	8.8	5.0	10.5	0.2

(Horizontal chip type)

● □9.5×24.0 (8 pin type)

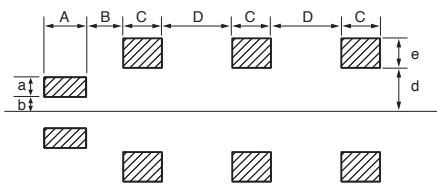

(Unit : mm)

	8 pin
A	4.0
B	1.0
C	3.0
D	5.5
a	1.5
b	1.0
d	3.0
e	2.0
Thickness of Solder paste	0.15

● □9.5×19.0 (6 pin type)

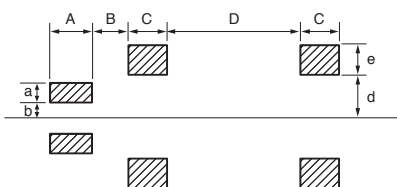

(Unit : mm)

	6 pin
A	4.0
B	1.0
C	3.0
D	9.0
a	1.5
b	1.0
d	3.0
e	2.0
Thickness of Solder paste	0.15

NOTE

Design, Specifications are subject to change without notice.
 Ask factory for technical specifications before purchase and/or use.

■ Recommended soldering conditions

● Aluminum electrolytic capacitors (Lead free)

(1) Methods

See the following

Methods	Reflow soldering	Soldering iron	Flow soldering
Advisability	×	○	○

(2) Soldering iron conditions

Iron tip temperature shall be $400^{\circ}\text{C} \pm 5^{\circ}\text{C}$ within the duration of 3rd seconds.

(3) Flow soldering conditions

The recommendation soldering conditions of the product in which flow soldering is possible are as graph.

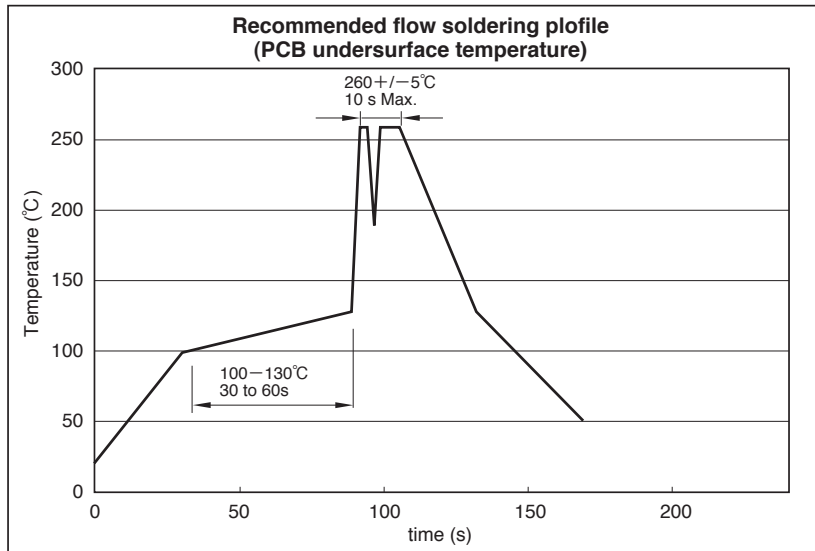

Caution for Using aluminum Electrolytic Capacitors

- (1) Do not dip the capacitor into melted solder.
- (2) Do not flux other part than the terminals.
- (3) If there is a direct contact between the sleeve of the capacitor and the printed circuit pattern or a metal part of another component such as a lead wire, it may cause shrinkage or crack.
- (4) If the application is for extended use, understand and manage the soldering characteristics to avoid abnormal current caused by a contact failure between the capacitor and the PCB.
- (5) Please refer to cautions for using on page 44 to 47 and product specifications about other notes.

Recommended soldering conditions

Chip type aluminum electrolytic capacitors (Lead free)

(1) Methods
See the following

Methods	Reflow soldering	Soldering iron	Flow soldering
Advisability	○	○	×

(2) Soldering iron conditions
Iron tip temperature shall be 400°C±5°C within the duration of 3¹/₂seconds.

(3) Reflow soldering conditions

Profile

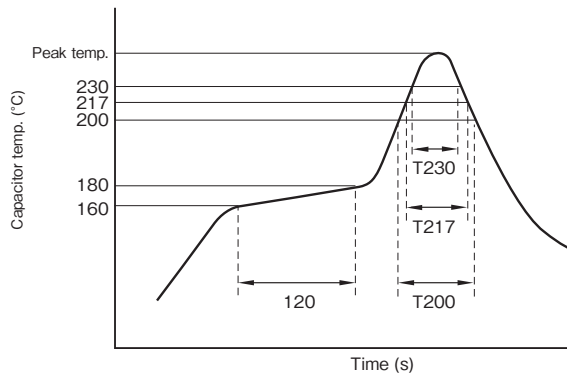

1. Preheating shall be under 180°C within 120 seconds.
2. Peak temperature shall be within the peak temperature matrix.
3. For conditions exceeding the tolerances, consult with us.

T200 : Duration while capacitor head temperature exceeds 200°C (s)
T217 : Duration while capacitor head temperature exceeds 217°C (s)
T230 : Duration while capacitor head temperature exceeds 230°C (s)
The measurement temperature point is the case top.

	Peak temp. matrix	Series
condition (1)		RV2, RV3, RV4 (φ4, 5), RV5 (φ4 to 6.3), RVB, RVE, RVS (φ4 to 6.3), RVL, RVR (φ4 to 6.3), RVC (φ4 to 6.3), RVD (φ4 to 6.3), RVV (φ4 to 6.3), RVZ (φ4 to 6.3), RVT (φ4 to 6.3), RVI, PVG (φ5, 6.3), PVX (φ5, 6.3) PV2, PVM (φ5, 6.3), PVH (φ6.3), PVK (φ6.3), PVS (φ6.3)
		RV, RV4 (φ6.3), RV5 (φ8, 10), RVS (φ8, 10), RVR (φ8, 10), RVJ (φ8, 10), RVC (φ8, 10), RVD (φ8, 10), RVV (φ8, 10), RVZ (φ8, 10), RVT (φ8, 10), RVK (φ8, 10), RVX, RTJ, RTK, PVG (φ8, 10), PVX (φ8, 10) PVM (φ8, 10), PVH (φ8, 10), PVK (φ8, 10), PVS (φ8, 10)
		RVJ (φ12.5), RVZ (φ12.5), RVK (φ12.5), RYK
condition (2)		RTZ (φ8, 10), RTD (φ8, 10), RTT (φ8, 10)
		RTZ (φ12.5 to 18), RTD (φ12.5 to 18), RTT (φ12.5 to 18)
condition (3)	Peak temp.: 260°C T217 : 90s max. T230 : 40s max.	RZA (φ4 to 6.3), RZB (φ4 to 6.3), RZC (φ4 to 6.3)
	Peak temp.: 250°C T217 : 90s max. T230 : 40s max.	RZA (φ8, 10), RZB (φ8, 10), RZC (φ8, 10)

■ Taping

■ Carrier tape dimension (taping polarity R)

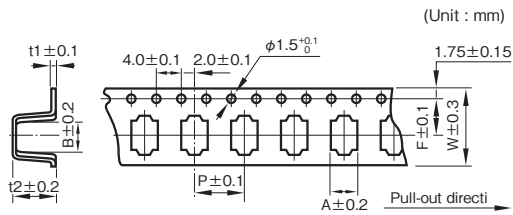

● Series RYK,

RV, RVJ, RVZ, RVK ($\phi 12.5$),
RTZ, RTD, RTT ($\phi 12.5$ to 18)

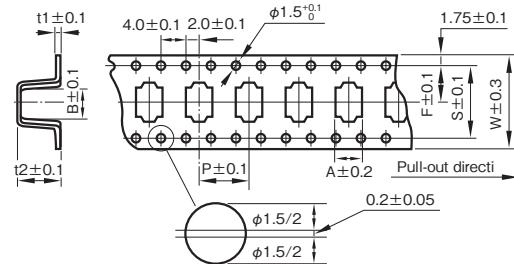

■ Taping polarity

(The all series except RVB and RYK)

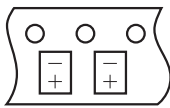

(Series RYK)

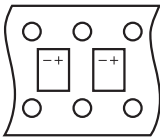

(Unit : mm)

Outside size $\phi D \times L$	W	A	B	P	t2	F	t1	S
3×5.3	12	3.4	3.4	8.0	5.9	5.5	0.4	—
4×4.5	12	4.7	4.7	8.0	4.8	5.5	0.4	—
4×5.3	12	4.7	4.7	8.0	5.8	5.5	0.4	—
4×5.7, 5.8	12	4.7	4.7	8.0	6.2	5.5	0.4	—
5×4.5	12	5.7	5.7	12	4.8	5.5	0.4	—
5×5.3	12	5.7	5.7	12	5.8	5.5	0.4	—
5×5.7, 5.8	12	5.7	5.7	12	6.2	5.5	0.4	—
6.3×4.5	16	7.0	7.0	12	4.8	7.5	0.4	—
6.3×5.3	16	7.0	7.0	12	5.8	7.5	0.4	—
6.3×5.7, 5.8	16	7.0	7.0	12	6.2	7.5	0.4	—
6.3×7.7	16	7.0	7.0	12	8.3	7.5	0.4	—
8×6.5	16	8.7	8.7	12	6.8	7.5	0.4	—
8×6.7	24	8.7	8.7	12	7.2	11.5	0.4	—
8×10	24	8.7	8.7	16	11	11.5	0.4	—
8×10.5	24	8.7	8.7	16	11.5	11.5	0.4	—
10×7.7	24	10.7	10.7	16	8.2	11.5	0.4	—
10×10	24	10.7	10.7	16	11	11.5	0.4	—
10×10.5	24	10.7	10.7	16	11.5	11.5	0.4	—
* 12.5×13.5	32	13.4	13.4	24	14.5	14.2	0.5	28.4
* 12.5×16	32	13.4	13.4	24	17	14.2	0.5	28.4
* 16×16.5	44	17	17	28	17.5	20.2	0.5	40.4
* 16×21.5	44	17	17	28	22.5	20.2	0.5	40.4
* 18×16.5	44	19	19	32	17.5	20.2	0.5	40.4
* 18×21.5	44	19	19	32	22.5	20.2	0.5	40.4
* 9.5×19.0	44	9.9	22.9	16	9.5	20.2	0.4	40.4
* 9.5×24.0	44	9.9	27.9	16	9.5	20.2	0.4	40.4

■ Reel dimension

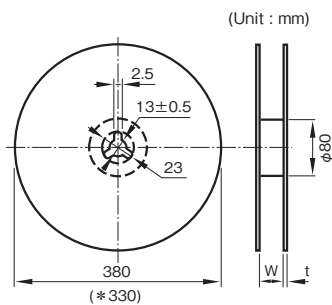

(Unit : mm)

Outside size $\phi D \times L$	Reel dimension	
	W	t
3, 4	14	3
5	14	3
6.3	18	3
8×6.5	18	3
8×6.7	26	3
8, 10	26	3
* 12.5	34	3
* 16	46	3
* 18	46	3
* 9.5×19.0	45	3
* 9.5×24.0	45	3

■ Packing quantity (Reel)

Outside size $\phi D \times L$	Quantity (PCS.)
3, 4	2000
5, 6.3	1000
8×6.5	1000
8×6.7	1000
* 8, 10	500
* 12.5×13.5	200
* 12.5×16	150
* 16×16.5	125
* 16×21.5	75
* 18×16.5	125
* 18×21.5	75
* 9.5×19.0	400
* 9.5×24.0	400

■ Reel material

Card board : symbol R
Polystyrene : symbol R2

Lead Forming

• In order to facilitate insertion into printed circuit board, lead wires are cut or formed.

Product Size Table

Unit: mm

Forming name	Lead forming symbol	Dimension		Style	Outline drawing
		F (Lead pitch)	φD (Case diameter)		
Forming cut	F10	2.0	4	B	
	F1		5	A	
	F12	2.5	4 to 5	B	
	F1		6.3	B	
	F1	3.5	8	A	
	F4		4 to 8	B	
	F	5.0	4 to 8	B	
	F		10 to 12.5	A	
F	7.5	16 to 18	A		
Snap-in	S1	5.0	4 to 8	B	
	S1		10 to 12.5	A	
	S1	7.5	16 to 18	A	
Forming cut (restrict series)	F49	5.0	10 to 12.5		
	F51		10 to 12.5		
	F58	10			
	F49	7.5	16 to 18		
	F51		16 to 18		

Forming name	Lead forming symbol	Dimension				Outline drawing
		F (Lead pitch)	φD (Case diameter)	ℓ ₀	ℓ ₁	
For 90°C side mount of case	G9, G10	3.5	8	5.5	1.0	
	G59, G60		8	3.6	1.0	
	G9, G10	5.0	10 to 12.5	5.5	1.0	
	G55, G56		12.5	7.5	2.5	
	G59, G60		10 to 12.5	3.6	1.0	
	G95, G96		12.5	0.95	4.9	
	G99, GA0		10	1.0	1.9	
	GAS, GAT		10 to 12.5	4.5	1.0	
	G9, G10	7.5	16 to 18	5.5	1.0	
	GAS, GAT		16 to 18	4.5	1.0	

NOTE
Design, Specifications are subject to change without notice.
Ask factory for technical specifications before purchase and/or use.

■ Taping

- For automatic insertion (radial lead type)

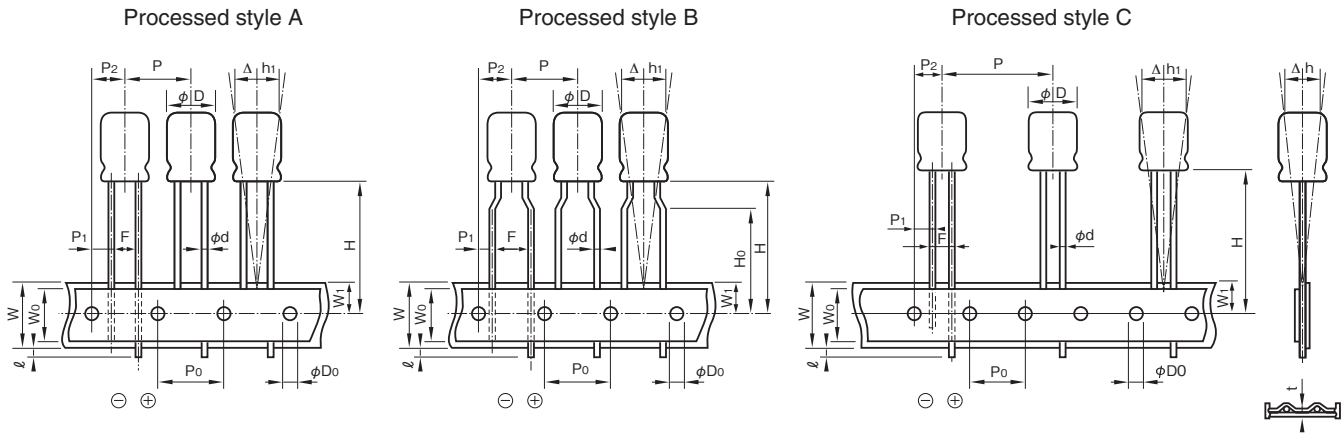

*The shape of a lead wire sandwiched by the mounting strips may differ from the ones shown in the figures.

Product Size Table

Unit: mm

Item	Symbol	Tolerance	5L to 7L		
			φ3 to φ8(except φ8×7L)		φ4 to φ8
Lead forming symbol	—	—	T36	T58	T2
Style	—	—	A or B		B
Lead-wire diameter	φd	±0.05	0.4 or 0.45		
Lead to lead distance	F	+0.8 -0.2	2.5		5.0
Height of component from tape center	H	+0.75 -0.5	18.5	17.5	
Lead-wire clinch height	H0	±0.5	—	16.0	
Pitch of componet	P	±1.0	12.7		
Feed hole pitch	P0	±0.3	12.7		
Hole center to lead	P1	±0.5	5.1		3.85
Hole center to component	P2	±1.0	6.35		
Tape width	W	±0.5	18.0		
Hold down tape width	W0	Min.	6.0		
Feed hole position	W1	±0.5	9.0		
Max. lead protrusion	ℓ	Max.	1.0		
Feed hole diameter	φD0	±0.2	4.0		
Alignment of component to center	Δh	±1.0	0		
Alignment of component to center	Δh1	±1.0	0		
Total tape thickness	t	±0.2	0.7		

NOTE

Design, Specifications are subject to change without notice.
Ask factory for technical specifications before purchase and/or use.

Taping

• For automatic insertion (radial lead type)

Product Size Table

Unit: mm

Item	Symbol	Tolerance	11L to 25L					
			φ5, φ6.3			φ8	φ10	φ12.5
Lead forming symbol	—	—	T36	T58	T2	T2	T2	T4
Style	—	—	A or B		B		A	
Lead-wire diameter	φd	±0.05	0.5 or 0.6			0.6		
Lead to lead distance	F	+0.8 -0.2	2.5		5.0			
Height of component from tape center	H	+0.75 -0.5	18.5	17.5	18.5	20.0	18.5	
Lead-wire clinch height	H ₀	±0.5	—		16.0		—	
Pitch of componet	P	±1.0	12.7					15.0
Feed hole pitch	P ₀	±0.3	12.7					15.0
Hole center to lead	P ₁	+0.5 (10 to φ18 ±0.7)	5.1		3.85			5.0
Hole center to component	P ₂	±1.0	6.35					7.5
Tape width	W	±0.5	18.0					
Hold down tape width	W ₀	Min.	6.0					
Feed hole position	W ₁	±0.5	9.0					
Max. lead protrusion	ℓ	Max.	1.0					
Feed hole diameter	φD ₀	±0.2	4.0					
Alignment of component to center	Δh	±1.0	0					
Alignment of component to center	Δh ₁	±1.0	0					
Total tape thickness	t	±0.2	0.7					

Part numbering system (example: Series RJB, 10V470μF, 5mm pitch taping)

RJB	—	10	V	471	M	G3	#	—	T2
Series code		Rated voltage symbol		Rated capacitance symbol	Capacitance tolerance symbol	Casing symbol			Taping symbol

■ Standard packing specification of aluminium electrolytic capacitors (taping article)

Classification	Chip type	
	Aluminium electrolytic capacitors	Aluminium electrolytic capacitors with conductive polymer solid electrolyte
Packing style	<p>Reel</p> <p>Inner box</p>	<p>Reel</p> <p>Dampproof bag</p> <p>Inner box</p>

Classification	Lead terminal type
Packing style	<p>Flat box</p> <p>Inner box</p>

Please inquire for details.

■ Standard packing specification of aluminium electrolytic capacitors
(long lead, lead forming)

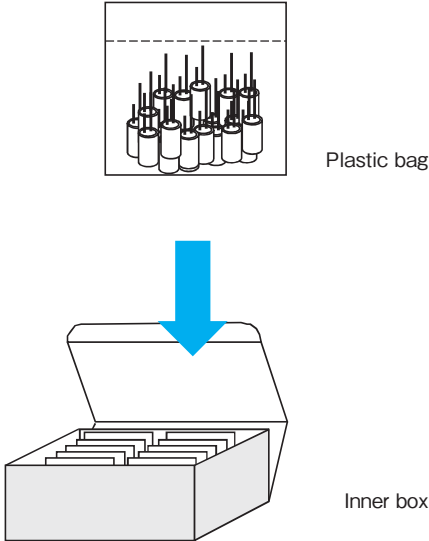
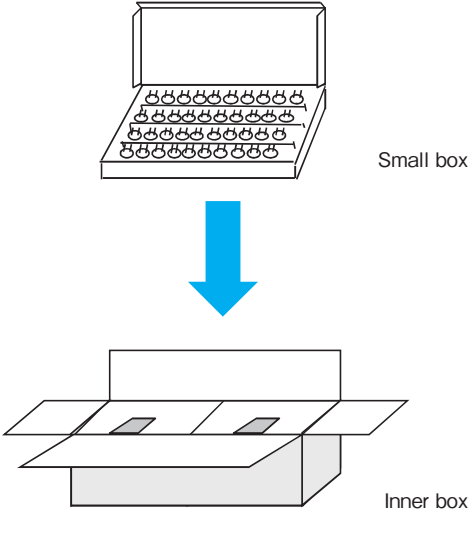
Size	$\phi 3$ to $\phi 10$	$\phi 12.5$ to $\phi 18$
Packing style	 <p>Plastic bag</p> <p>Inner box</p>	 <p>Small box</p> <p>Inner box</p>

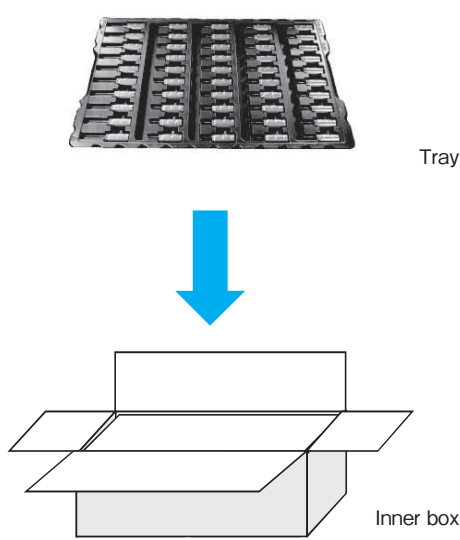
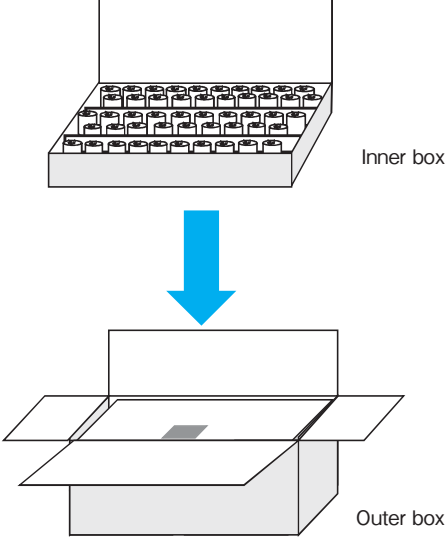
Size	$\phi 10$ to $\phi 18$	$\phi 22$ or more
Packing style	 <p>Tray</p> <p>Inner box</p>	 <p>Inner box</p> <p>Outer box</p>

Please inquire for details.

MEMO

Aluminum Electrolytic Capacitors With Conductive Polymer Solid Electrolyte

■ Cautions for Using Aluminum Electrolytic Capacitors With Conductive Polymer Solid Electrolyte

Please be sure to read this specification before using this product.

Before placing an order, please inquire about the Product Specification to check details.

■ Cautions for Usage

1. Solid conductive polymer aluminum electrolytic capacitors are polarized.

- Using a capacitor with reversed polarity causes abnormal current flow, resulting in a short circuit.
- Cannot use for the circuit to which the polarity reverses by ripple voltage.

2. Prohibited Circuits

- Since leakage current problem may arise, capacitors cannot be used in the following circuits.
 - ① Coupling circuits
 - ② Circuits greatly affected by leakage current

3. Use capacitors within the rated voltage.

- The application of voltages exceeding the rated voltage can significantly increase leakage current, resulting in a short failure. Please do not apply a voltage exceeding the rated voltage.

4. Be careful of excessive rush current.

- Using capacitors in the circuit where excessive rush current passes may cause characteristic deterioration or a short. When the rush current exceeds 10 A, we recommend use of protection circuits to ensure high reliability.

5. Use the allowable ripple voltage and the rated ripple current below the specified values.

- When superimposing a ripple voltage on a DC bias voltage, exercise care that the peak voltage value does not exceed the rated voltage and does not reverse the polarity.
- The rated ripple current shall be below the specified value.

6. Changes in characteristics due to operating temperature

- The characteristics of solid conductive polymer aluminum electrolytic capacitors vary by temperature as follows. These variations are temporary and recover when the temperature goes back (except for the case of characteristic deterioration because of high temperatures over a long time).

Note that using capacitors over the upper category temperature increases leakage current, resulting in a short and destruction.

Be careful of the capacitor temperature considering not only the ambient temperature where the equipment is placed and the temperature inside the equipment but also radiation heat from the heating element inside the equipment, and self-heat

generation by ripple current.

- ① Capacitance expressed in the value at 20°C, 120 Hz increases with increased temperature and decreases with decreasing temperature.
- ② Tangent of loss angle ($\tan\delta$) expressed in the value at 20°C, 120 Hz is temperature-independent.
- ③ Equivalent series resistance (ESR) expressed in the value at 20°C, 100 kHz is temperature independent.
- ④ Leakage current increases with increased temperature and decreases with decreasing temperature.

7. Changes in characteristics due to frequency

- The characteristics of solid conductive polymer aluminum electrolytic capacitors vary by operating frequency as follows.

- ① Capacitance expressed in the value at 20°C, 120 Hz decreases with increased frequency.
- ② Tangent of loss angle ($\tan\delta$) expressed in the value at 20°C, 120 Hz increases with increased frequency.
- ③ Equivalent series resistance (ESR) expressed in the value at 20°C, 100 kHz increases with decreasing frequency.

8. Failure modes of solid conductive polymer aluminum electrolytic capacitors

- The failure modes of solid conductive polymer aluminum electrolytic capacitors are a wear-out failure by deterioration of electrical performance and a random failure by a short. The failure rate level is 0.5%/1,000h at the reliability level of 60% with the specified voltage applied at 105°C.
- If a short occurs and continues with the application of a voltage exceeding the rated voltage, increasing the internal temperature, the internal pressure increases by vaporization of the cathode material, which may cause the aluminum case to come off.

9. Operating environments

- Do not use capacitors in an environment directly exposed to water, saltwater spray, oil spill or condensation.
- Do not use capacitors in an environment filled with toxic gas such as hydrogen sulfide, sulfurous acid, nitrous acid, chlorine, ammonia, etc.
- Do not use capacitors in a place exposed to ozone, ultraviolet rays, or radiation.

10. Fumigation Process

- Before transportation of electronic equipment to overseas, fumigation process may be subjected to wooden packing material with a halogen (compound) gas such as methyl bromide. Exercise care that this halogen gas may corrode capacitors. Also, be careful of epidemic preventive agent as corrosive component such as halogen may be contained.

11. The case of solid conductive polymer aluminum electrolytic capacitors and the cathode terminal are not insulated.

- The case and the cathode terminal are not insulated as being connected through inconstant resistance.

12. Double-sided PCB's

- When using capacitors on a double-sided PCB, exercise care that the wiring pattern does not touch the area where the capacitors are mounted. Failure to do so may cause a short to occur to the PCB depending on the mounting conditions.

13. Regarding Connection of Solid Conductive Polymer Aluminum Electrolytic Capacitors

- When connecting more than one capacitor in parallel, consider the current balance.

14. Use at a high altitude

- The use of capacitors at high altitudes such as on an airplane causes a large difference between the internal pressure of the capacitors and the atmospheric pressure. However, there is no problem in use under atmospheric pressure up to about an altitude of 10,000 meters.
If the condition is severe like space, please contact us.

15. Other Notes

- Do not use capacitors on a circuit where rapid charge and discharge are repeated.
- Electrical characteristics of capacitors vary by variations in temperature and frequency. Please consider these variations when designing a circuit.

■ Cautions for Mounting

1. Cautions for Mounting

- Do not reuse capacitors that have been assembled in a set and energized. Capacitors cannot be reused except for those which have been measured on electrical performance during periodic inspection.
- Before mounting, confirm the capacitor ratings (rated capacitance and rated voltage).
- Capacitors may generate transient recovery voltage. In this case, discharge through a resistor of about 1 k Ω .
- Before mounting, confirm the polarity of capacitor.

- Do not drop capacitors onto a floor nor use them.
- Do not mount deformed capacitors.
- Do not mount heating parts around capacitors and on the back of the PCB under or back of capacitors).

2. Do not apply excessive pressure to the capacitor or its terminals

- Be careful of the shock force that can be produced by absorbers, product checkers, and centering on automatic inserters and installers.

3. Soldering

- Do not solder capacitor body by dipping into melted solder.
- Soldering conditions (preheating, soldering temperature, terminal dipping time) should be within the ranges specified in the catalog or the delivery specification.
- Flux should not adhere to the parts other than the terminals.
- When using a soldering iron, avoid excessive stress to capacitor body.
- In reflow soldering, the reflow should be conducted once. Please be sure to consult with us if reflow must be conducted twice.
- Although leakage current may increase (from a few μA to hundreds of μA) after soldering, it can be reduced through self-repair by applying voltage. It is advised to operate the set properly after treating with the recommended voltage.
- In case of a long-term use of equipment, control the soldering characteristics so that capacitors and PCB do not fail to connect to avoid abnormal current passage by a failure of soldering to mount.

4. Handling after Soldering

- Do not tilt, fall, raise or twist capacitor body.
- Do not pick up or move PCB by holding a capacitor.
- Do not bump capacitors against objects. When stacking PCB's, make sure that capacitors do not touch the PCB's or other components.
- Do not subject capacitors to excessive stress.

5. Cleaning after Soldering

- Recommended cleaning method
 - ① Cleaning solutions:
 - (a) CLEANTHROUGH 710M, 750H, 750L
 - (b) PINEALPHA ST-100S
 - (c) Techno Care FRW-4~17
 - (d) Isopropyl alcohol (2-propanol)
 - ② Cleaning conditions:
 - (a) The temperature of cleaning solution shall be less than 60°C.
 - (b) Use immersion or ultrasonic waves within two minutes.

NOTE

Design, Specifications are subject to change without notice.
Ask factory for technical specifications before purchase and/or use.

(c) After cleaning, capacitors and PCB's shall thoroughly be rinsed and dried with hot blast for more than 10 minutes. The temperature of such breeze should be less than the upper category temperature.

(d) After cleaning, do not keep capacitors in cleaning solution atmosphere or airtight containers.

- During cleaning, control the cleaning solution against contamination.

6. Fixing adhesives and coating materials.

- Do not use halogenated fixatives and coatings.
- Before using a fixative or coating, remove flux residues and contaminants from between the PCB and the sealing section of capacitors.
- Dry the cleaning solution before using the adhesive or coating.
- Do not cover up all the sealing sections (terminal side) of capacitors with the adhesive or coating.
- Heat curing conditions of fixative and coating.

■ Other Cautions

1. Do not directly touch the terminals of solid conductive polymer aluminum electrolytic capacitors.

Failure to do so can cause electric shock or burns. Before use, allow capacitors to discharge through a 1kΩ resistor (with a sufficient margin to the heat generation capacity) as needed.

2. Do not short-circuit between the terminals of the solid conductive polymer aluminum electrolytic capacitors with electric conductor. Do not subject capacitors to conductive solutions such as acid and alkaline water solutions.

3. Periodic inspection should be performed on the capacitors for the industrial equipment application.

Check the following checkpoints.

- Visual inspection to check for significant defects.
- Electrical performance: leakage current, rated capacitance, tangent of loss angle, ESR, and items specified in the catalog or delivery specification.

4. Be careful of the following cases of emergency.

- In case of a short during use of capacitors in sets, producing gas, turn off the main power of the set or unplug the power cord from the outlet.
- In case of a short, producing gas, it may take a few seconds to a few minutes depending on the conditions. Therefore, ensure that the protective circuit of the power supply works during this time.
- If the gas gets in your eyes, rinse them immediately. Gargle if the gas is inhaled.
- Do not lick the electrolyte of capacitors. When the

electrolyte gets on your skin, wash it off with soap immediately.

5. Storage Conditions.

- Do not store at high temperature and high humidity. Store at a temperature of 5 to 35°C and a relative humidity of less than 75%, keeping free from direct sunlight.
- During delivery, capacitors are stored in airtight moistureproof bags to ensure satisfactory soldering. Once the bag is opened right before mounting, it is better to use up the capacitors. If some are unavoidably left over, return them to the moistureproof bag, and seal the opening hermetically.
- Solid conductive polymer aluminum electrolytic capacitors may have increased leakage current when unused or stored for a long time after mounted on equipment. This phenomenon often occurs at high ambient temperatures; however, leakage current will decrease through voltage treatment. If leakage current still increases after a lapse of more than one year at ambient temperature (shorter time at high temperatures), treat with voltage as needed. In design of equipment, consider the effect of increase in initial current, and install protective circuits as needed.

Please check that recommended voltage treatment conditions are provided for each series.

- Do not store capacitors in an environment directly exposed to water, saltwater spray, oil spill or condensation.
- Do not store capacitors in an environment filled with toxic gas such as hydrogen sulfide, sulfurous acid, nitrous acid, chlorine, ammonia, etc.
- Do not store capacitors in a place exposed to ozone, ultraviolet rays, or radiation.

6. Please take the following actions when disposing of solid conductive polymer aluminum electrolytic capacitors.

- Entrust to specialists of industrial waste treatment for incineration.

7. Others

- Before using capacitors, check the details of this delivery specification and catalog as well as the following.

Technical Report of Japan Electronics and Information Technology Industries Association
EIAJ RCR-2367B

Guideline of notabilia for fixed aluminum electrolytic capacitors for use in electronic equipment

MEMO

Chip Type GREEN CAP SMD Low ESR 105°C 2000hours Anti-cleaning solvent

- Super low E.S.R. and high ripple current are realized.
- Guaranteed 105°C, 2000 hours.

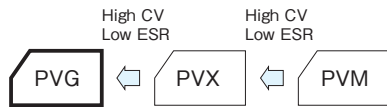

Specifications

Item	Performance	
Category temperature range (°C)	-55 to +105	
Tolerance at rated capacitance (%)	±20 (20°C, 120Hz)	
Leakage current (μA) *Note	Less than 0.2CV C : Rated capacitance (μF) ; V : Rated voltage (V) (20°C)	
Tangent of the loss angle (tanδ)	Less than 0.12 (20°C, 120Hz)	
Characteristics at high and low temperature	Impedance ratio (max.) Z-25°C / Z+20°C : 1.15 Z-55°C / Z+20°C : 1.25 (100kHz)	
Endurance (105°C) (Applied ripple current)	Test time	2000 hours
	Leakage current	The initial specified value or less
	Percentage of capacitance change	Within ±20% of initial value
	Tangent of the loss angle	150% or less of the initial specified value
	E.S.R. change	150% or less of the initial specified value
Bias Humidity 60°C, 90 to 95%RH	Test time	500 hours
	Leakage current	The initial specified value or less
	Percentage of capacitance change	Within ±20% of initial value
	Tangent of the loss angle	150% or less of the initial specified value
	E.S.R. change	150% or less of the initial specified value
Characteristics of applied surge voltage	The capacitors shall be subject to 1000 cycles each consisting of charge with the surge voltage specified at 105°C for 30 seconds through a protective resistor (Rc=1kΩ) in 6 minutes per cycle. Surge voltage : 1.15 times of rated voltage	
	Leakage current	The initial specified value or less
	Percentage of capacitance change	Within ±20% of initial value
	Tangent of the loss angle	150% or less of the initial specified value
	E.S.R. change	150% or less of the initial specified value
Failure rate	0.5% per 1000 hours maximum (Confidence level 60% at 105°C)	

*Note : If any doubt arises, measure the leakage current after following voltage application treatment.
Voltage application treatment : DC rated voltage are applied to the capacitors for 120 minutes at 105°C.

Outline Drawing

Unit : mm

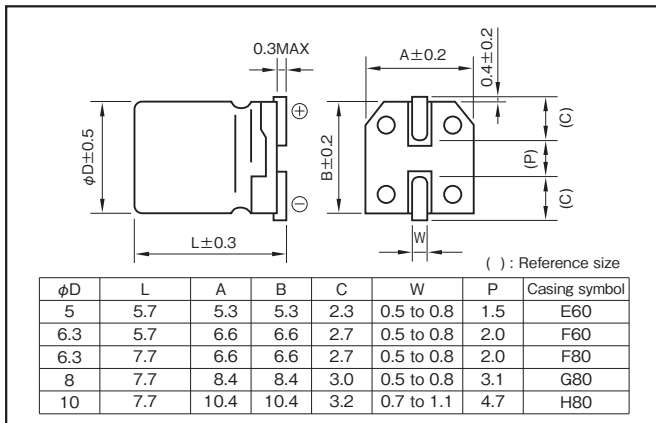

- Soldering conditions are described on page 13.
- Land pattern size are described on page 11.
- The taping specifications are described on page 14.

Series code	Rated voltage symbol	Rated capacitance symbol	Capacitance tolerance symbol	Casing symbol	Taping symbol
PVG	4	V	151	M	E60

Example : 4V150μF

Standard Ratings

Rated voltage (V) Rated capacitance (µF)	Item	2.5			4			6.3		
		Case	ESR	Rated ripple current	Case	ESR	Rated ripple current	Case	ESR	Rated ripple current
		φD×L (mm)	(mΩ max.)	(mA _{rms})	φD×L (mm)	(mΩ max.)	(mA _{rms})	φD×L (mm)	(mΩ max.)	(mA _{rms})
120	—	—	—	—	—	—	5×5.7	8	4000	
150	—	—	—	5×5.7	8	4000	—	—	—	
220	5×5.7	8	4000	6.3×5.7	6	4500	6.3×5.7	7	4300	
270	—	—	—	6.3×5.7	6	4500	6.3×7.7	7	4600	
330	6.3×5.7	6	4500	6.3×7.7	6	4800	8×7.7	7	4700	
390	6.3×5.7	6	4500	6.3×7.7	6	4800	—	—	—	
470	6.3×7.7	6	4800	8×7.7	6	5000	8×7.7	7	4700	
560	6.3×7.7	6	4800	—	—	—	8×7.7	7	4700	
680	—	—	—	8×7.7	6	5000	—	—	—	
820	—	—	—	—	—	—	10×7.7	7	4900	
1000	8×7.7	6	5000	10×7.7	6	5200	—	—	—	
1200	10×7.7	6	5200	—	—	—	—	—	—	

(Note) Rated ripple current : 105°C, 100kHz ; E.S.R. : 20°C, 100kHz

Aluminum Electrolytic Capacitors
With Conductive Polymer Solid
Electrolyte

Chip Type GREEN CAP SMD Low ESR 105°C 2000hours Anti-cleaning solvent

- Super low E.S.R. and high ripple current are realized.
- Guaranteed 105°C, 2000 hours.

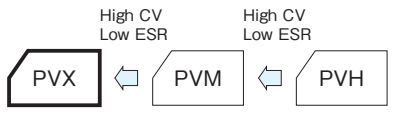

Specifications

Item	Performance	
Category temperature range (°C)	-55 to +105	
Tolerance at rated capacitance (%)	±20 (20°C, 120Hz)	
Leakage current (µA) *Note	Less than 0.2CV C : Rated capacitance (µF) ; V : Rated voltage (V) (20°C)	
Tangent of the loss angle (tanδ)	Less than 0.12 (20°C, 120Hz)	
Characteristics at high and low temperature	Impedance ratio (max.) Z-25°C / Z+20°C : 1.15 Z-55°C / Z+20°C : 1.25 (100kHz)	
Endurance (105°C) (Applied ripple current)	Test time	2000 hours
	Leakage current	The initial specified value or less
	Percentage of capacitance change	Within ±20% of initial value
	Tangent of the loss angle	150% or less of the initial specified value
	E.S.R. change	150% or less of the initial specified value
Bias Humidity 60°C, 90 to 95%RH	Test time	500 hours
	Leakage current	The initial specified value or less
	Percentage of capacitance change	Within ±20% of initial value
	Tangent of the loss angle	150% or less of the initial specified value
	E.S.R. change	150% or less of the initial specified value
Characteristics of applied surge voltage	The capacitors shall be subject to 1000 cycles each consisting of charge with the surge voltage specified at 105°C for 30 seconds through a protective resistor (Rc=1kΩ) in 6 minutes per cycle. Surge voltage : 1.15 times of rated voltage	
	Leakage current	The initial specified value or less
	Percentage of capacitance change	Within ±20% of initial value
	Tangent of the loss angle	150% or less of the initial specified value
	E.S.R. change	150% or less of the initial specified value
Failure rate	0.5% per 1000 hours maximum (Confidence level 60% at 105°C)	

*Note : If any doubt arises, measure the leakage current after following voltage application treatment.
Voltage application treatment : DC rated voltage are applied to the capacitors for 120 minutes at 105°C.

Outline Drawing

Unit : mm

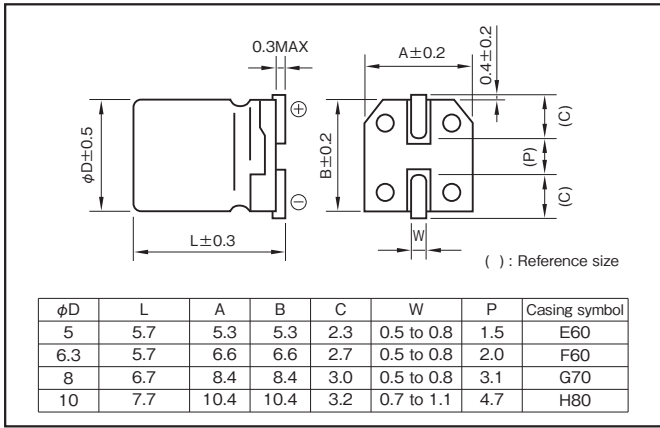

Part numbering system (example : 4V150µF)

PVX	—	4	V	151	M	E60	E	—	□
Series code		Rated voltage symbol		Rated capacitance symbol	Capacitance tolerance symbol	Casing symbol			Taping symbol

- Soldering conditions are described on page 13.
- Land pattern size are described on page 11.
- The taping specifications are described on page 14.

Aluminum Electrolytic Capacitors With Conductive Polymer Solid Electrolyte

Standard Ratings

Rated voltage (V) Rated capacitance (μF)	Item	2.5			4			6.3			10		
		Case	ESR	Rated ripple current	Case	ESR	Rated ripple current	Case	ESR	Rated ripple current	Case	ESR	Rated ripple current
		φD×L (mm)	(mΩ max.)	(mA rms)	φD×L (mm)	(mΩ max.)	(mA rms)	φD×L (mm)	(mΩ max.)	(mA rms)	φD×L (mm)	(mΩ max.)	(mA rms)
100	—	—	—	—	—	—	5×5.7	15	3100	5×5.7	15	3100	
120	—	—	—	—	—	—	—	—	—	6.3×5.7	13	3300	
150	5×5.7	10	3800	5×5.7	10	3800	5×5.7	15	3100	—	—	—	
220	5×5.7	10	3800	5×5.7	10	3800	6.3×5.7	9	4000	8×6.7	10	3800	
270	5×5.7	10	3800	—	—	—	—	—	—	—	—	—	
330	6.3×5.7	9	4000	6.3×5.7	9	4000	8×6.7	8	4300	8×6.7	10	3800	
390	6.3×5.7	9	4000	—	—	—	8×6.7	8	4300	—	—	—	
470	8×6.7	8	4300	8×6.7	8	4300	8×6.7	8	4300	10×7.7	10	4000	
560	8×6.7	8	4300	8×6.7	8	4300	—	—	—	—	—	—	
680	8×6.7	8	4300	10×7.7	8	4600	—	—	—	—	—	—	
820	—	—	—	—	—	—	10×7.7	8	4600	—	—	—	
1000	10×7.7	8	4600	10×7.7	8	4600	—	—	—	—	—	—	
1200	10×7.7	8	4600	—	—	—	—	—	—	—	—	—	

(Note) Rated ripple current : 105°C, 100kHz ; E.S.R. : 20°C, 100kHz

Aluminum Electrolytic Capacitors
With Conductive Polymer Solid
Electrolyte

Chip Type GREEN CAP SMD Low ESR 105°C 2000hours Anti-cleaning solvent

- 4.5mm high
- Super low E.S.R. and high ripple current are realized.
- Guaranteed 105°C, 2000 hours.

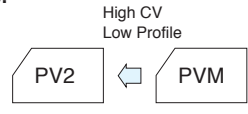
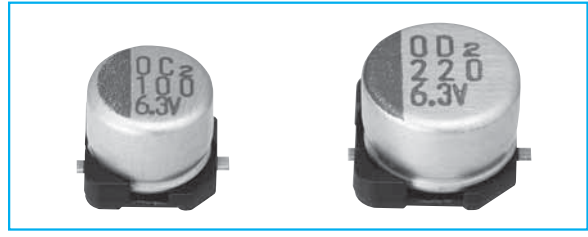

Specifications

Item	Performance	
Category temperature range (°C)	-55 to +105	
Tolerance at rated capacitance (%)	±20 (20°C, 120Hz)	
Leakage current (μA) *Note	Rated voltage (V)	2.5 to 20 25, 35
	Leakage current (μA)	Less than 0.2 CV Less than 0.5 CV
C : Rated capacitance (μF) ; V : Rated voltage (V)		
Tangent of the loss angle (tanδ)	Less than 0.12 (20°C, 120Hz)	
Characteristics at high and low temperature	Impedance ratio (max.)	
	Z-25°C/Z+20°C : 1.15 Z-55°C/Z+20°C : 1.25 (100kHz)	
Endurance (105°C) (Applied ripple current)	Test time	2000 hours
	Leakage current	The initial specified value or less
	Percentage of capacitance change	Within ±20% of initial value
	Tangent of the loss angle	150% or less of the initial specified value
	E.S.R. change	150% or less of the initial specified value
Bias Humidity 60°C, 90 to 95%RH	Test time	500 hours
	Leakage current	The initial specified value or less
	Percentage of capacitance change	Within ±20% of initial value
	Tangent of the loss angle	150% or less of the initial specified value
	E.S.R. change	150% or less of the initial specified value
Characteristics of applied surge voltage	The capacitors shall be subject to 1000 cycles each consisting of charge with the surge voltage specified at 105°C for 30 seconds through a protective resistor (Rc=1kΩ) in 6 minutes per cycle. Surge voltage : 1.15 times of rated voltage	
	Leakage current	The initial specified value or less
	Percentage of capacitance change	Within ±20% of initial value
	Tangent of the loss angle	150% or less of the initial specified value
	E.S.R. change	150% or less of the initial specified value
Failure rate	0.5% per 1000 hours maximum (Confidence level 60% at 105°C)	

*Note : If any doubt arises, measure the leakage current after following voltage application treatment.
Voltage application treatment : DC rated voltage are applied to the capacitors for 120 minutes at 105°C.

Outline Drawing

Unit : mm

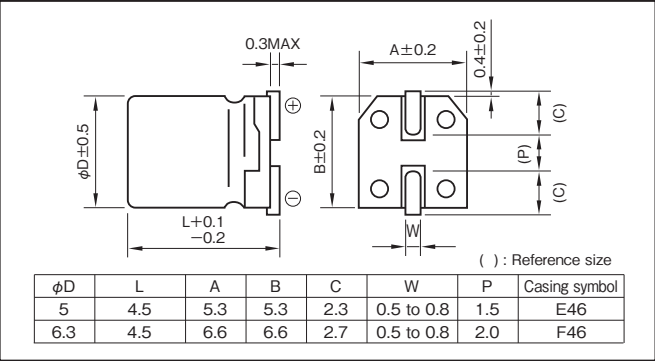

Part numbering system (example : 4V120μF)

PV2	—	4	V	121	M	E46	—	
Series code		Rated voltage symbol		Rated capacitance symbol	Capacitance tolerance symbol	Casing symbol		Taping symbol

- Soldering conditions are described on page 13.
- Land pattern size are described on page 11.
- The taping specifications are described on page 14.

Aluminum Electrolytic Capacitors With Conductive Polymer Solid Electrolyte

Standard Ratings

Rated voltage (V) Item Rated capacitance (μF)	2.5			4			6.3			10			16		
	Case	ESR	Rated ripple current	Case	ESR	Rated ripple current	Case	ESR	Rated ripple current	Case	ESR	Rated ripple current	Case	ESR	Rated ripple current
	φD×L (mm)	(mΩ max.)	(mAmps)	φD×L (mm)	(mΩ max.)	(mAmps)	φD×L (mm)	(mΩ max.)	(mAmps)	φD×L (mm)	(mΩ max.)	(mAmps)	φD×L (mm)	(mΩ max.)	(mAmps)
39	—	—	—	—	—	—	—	—	—	—	—	—	6.3×4.5	40	1450
100	—	—	—	—	—	—	5×4.5	20	1300	—	—	—	—	—	—
120	—	—	—	5×4.5	20	1400	—	—	—	6.3×4.5	30	1750	—	—	—
150	—	—	—	—	—	—	6.3×4.5	16	1950	—	—	—	—	—	—
180	5×4.5	20	1400	—	—	—	—	—	—	—	—	—	—	—	—
220	—	—	—	6.3×4.5	16	2400	6.3×4.5	16	1950	—	—	—	—	—	—
270	6.3×4.5	16	2400	—	—	—	—	—	—	—	—	—	—	—	—
330	6.3×4.5	13	2400	—	—	—	—	—	—	—	—	—	—	—	—
390	6.3×4.5	16	2400	—	—	—	—	—	—	—	—	—	—	—	—

Rated voltage (V) Item Rated capacitance (μF)	20			25		
	Case	ESR	Rated ripple current	Case	ESR	Rated ripple current
	φD×L (mm)	(mΩ max.)	(mAmps)	φD×L (mm)	(mΩ max.)	(mAmps)
15	—	—	—	6.3×4.5	45	1150
22	6.3×4.5	45	1250	—	—	—

(Note) Rated ripple current : 105°C, 100kHz ; E.S.R. : 20°C, 100kHz

Chip Type

- GREEN CAP
- SMD
- Low ESR
- 105°C 2000hours
- Anti-cleaning solvent

- Super low E.S.R. and high ripple current are realized.
- Guaranteed 105°C, 2000 hours.

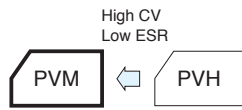

Specifications

Item	Performance	
Category temperature range (°C)	-55 to +105	
Tolerance at rated capacitance (%)	±20 (20°C, 120Hz)	
Leakage current (μA) *Note	Rated voltage (V) 2.5 to 20 25,35	
	Leakage current (μA) Less than 0.2 CV Less than 0.5 CV	
C : Rated capacitance (μF) ; V : Rated voltage (V) (20°C)		
Tangent of the loss angle (tanδ)	Less than 0.12 (20°C, 120Hz)	
Characteristics at high and low temperature	Impedance ratio (max.)	
	Z-25°C/Z+20°C : 1.15 Z-55°C/Z+20°C : 1.25 (100kHz)	
Endurance (105°C) (Applied ripple current)	Test time 2000 hours	
	Leakage current The initial specified value or less	
	Percentage of capacitance change Within ±20% of initial value	
	Tangent of the loss angle 150% or less of the initial specified value	
	E.S.R. change 150% or less of the initial specified value	
Bias Humidity 60°C, 90 to 95%RH	Test time 500 hours	
	Leakage current The initial specified value or less	
	Percentage of capacitance change Within ±20% of initial value	
	Tangent of the loss angle 150% or less of the initial specified value	
	E.S.R. change 150% or less of the initial specified value	
Characteristics of applied surge voltage	The capacitors shall be subject to 1000 cycles each consisting of charge with the surge voltage specified at 105°C for 30 seconds through a protective resistor (Rc=1kΩ) in 6 minutes per cycle. Surge voltage : 1.15 times of rated voltage	
	Leakage current The initial specified value or less	
	Percentage of capacitance change Within ±20% of initial value	
	Tangent of the loss angle 150% or less of the initial specified value	
	E.S.R. change 150% or less of the initial specified value	
Failure rate	0.5% per 1000 hours maximum (Confidence level 60% at 105°C)	

*Note : If any doubt arises, measure the leakage current after following voltage application treatment.
Voltage application treatment : DC rated voltage are applied to the capacitors for 120 minutes at 105°C.

Outline Drawing

Unit : mm

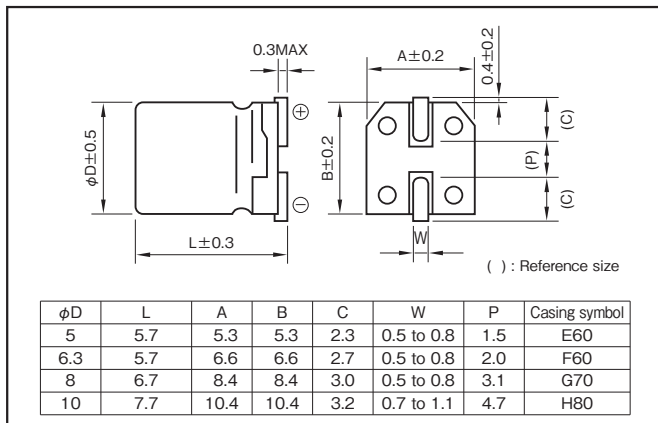

- Soldering conditions are described on page 13.
- Land pattern size are described on page 11.
- The taping specifications are described on page 14.

Part numbering system (example : 4V151M E60 E)					
PVM	4	V	151	M	E60 E
Series code	Rated voltage symbol	Rated capacitance symbol	Capacitance tolerance symbol	Casing symbol	Taping symbol

Standard Ratings

Rated voltage (V)	Item	2.5			4			6.3			10			16		
		Case	ESR	Rated ripple current	Case	ESR	Rated ripple current	Case	ESR	Rated ripple current	Case	ESR	Rated ripple current	Case	ESR	Rated ripple current
		φD×L (mm)	(mΩ max.)	(mAmps)	φD×L (mm)	(mΩ max.)	(mAmps)	φD×L (mm)	(mΩ max.)	(mAmps)	φD×L (mm)	(mΩ max.)	(mAmps)	φD×L (mm)	(mΩ max.)	(mAmps)
33	—	—	—	—	—	—	—	—	—	—	—	—	5×5.7	35	2070	
39	—	—	—	—	—	—	—	—	—	—	—	—	5×5.7	35	2070	
47	—	—	—	—	—	—	—	—	—	—	5×5.7	28	2310	6.3×5.7	28	2340
56	—	—	—	—	—	—	—	—	—	—	5×5.7	28	2310	—	—	—
68	—	—	—	—	—	—	—	—	—	—	5×5.7	28	2310	6.3×5.7	28	2340
100	—	—	—	5×5.7	22	2610	5×5.7	24	2500	6.3×5.7	25	2530	8×6.7	24	3010	
120	—	—	—	—	—	—	5×5.7	24	2500	6.3×5.7	25	2530	8×6.7	24	3010	
150	—	—	—	5×5.7	22	2610	—	—	—	—	—	—	—	—	—	
180	5×5.7	21	2670	—	—	—	—	—	—	—	—	—	—	—	—	
220	5×5.7	21	2670	5×5.7	22	2610	6.3×5.7	15	3160	8×6.7	21	3220	10×7.7	22	3450	
270	—	—	—	6.3×5.7	15	3160	—	—	—	8×6.7	21	3220	—	—	—	
330	6.3×5.7	15	3160	6.3×5.7	15	3160	8×6.7	14	3950	10×7.7	19	3800	—	—	—	
390	6.3×5.7	15	3160	—	—	—	8×6.7	14	3950	—	—	—	—	—	—	
470	8×6.7	13	3600	8×6.7	14	3950	8×6.7	14	3950	10×7.7	19	3800	—	—	—	
560	8×6.7	13	3600	8×6.7	14	3950	—	—	—	—	—	—	—	—	—	
680	8×6.7	13	3600	—	—	—	—	—	—	—	—	—	—	—	—	
820	—	—	—	—	—	—	10×7.7	14	4300	—	—	—	—	—	—	
1000	10×7.7	13	4450	10×7.7	14	4300	—	—	—	—	—	—	—	—	—	
1200	10×7.7	13	4450	—	—	—	—	—	—	—	—	—	—	—	—	

Aluminum Electrolytic Capacitors With Conductive Polymer Solid Electrolyte

Rated voltage (V)	Item	20			25			35		
		Case	ESR	Rated ripple current	Case	ESR	Rated ripple current	Case	ESR	Rated ripple current
		φD×L (mm)	(mΩ max.)	(mAmps)	φD×L (mm)	(mΩ max.)	(mAmps)	φD×L (mm)	(mΩ max.)	(mAmps)
10	—	—	—	6.3×5.7	60	1500	—	—	—	
15	—	—	—	—	—	—	8×6.7	150	1000	
22	6.3×5.7	50	1650	8×6.7	50	1800	—	—	—	
33	—	—	—	—	—	—	10×7.7	100	1800	
39	—	—	—	10×7.7	45	2100	—	—	—	
47	8×6.7	45	2000	—	—	—	—	—	—	
82	10×7.7	40	2500	—	—	—	—	—	—	

(Note) Rated ripple current : 105°C, 100kHz ; E.S.R. : 20°C, 100kHz

Chip Type GREEN CAP SMD Low ESR 105°C 2000hours Anti-cleaning solvent

- Super low E.S.R. and high ripple current are realized.
- Guaranteed 105°C, 2000 hours.

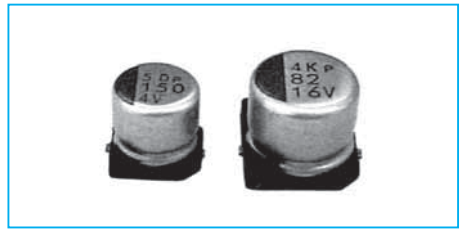

Specifications

Item	Performance	
Category temperature range (°C)	-55 to +105	
Tolerance at rated capacitance (%)	±20 (20°C, 120Hz)	
Leakage current (µA) *Note	Rated voltage (V)	2.5 to 20
	Leakage current (µA)	Less than 0.2 CV
C : Rated capacitance (µF) ; V : Rated voltage (V)		25,35 Less than 0.5 CV
Tangent of loss angle (tanδ)	Less than 0.12 (20°C, 120Hz)	
Characteristics at high and low temperature	Impedance ratio (max.) Z-55°C/Z+20°C : 1.50 (100kHz)	
Endurance (105°C) (Applied ripple current)	Test time	2000 hours
	Leakage current	The initial specified value or less
	Percentage of capacitance change	Within ±20% of initial value
	Tangent of the loss angle	150% or less of the initial specified value
	E.S.R. change	200% or less of the initial specified value
Damp heat, steady state (humidity) 60°C, 90 to 95%RH	Test time	500 hours
	Leakage current	The initial specified value or less
	Percentage of capacitance change	Within ±20% of initial value
	Tangent of the loss angle	150% or less of the initial specified value
	E.S.R. change	200% or less of the initial specified value
Characteristics of applied surge voltage	The capacitors shall be subject to 1000 cycles each consisting of charge with the surge voltage specified at 15 to 35°C for 30 seconds through a protective resistor (Rc=1kΩ) in 6 minutes per cycle. Surge voltage : 1.15 times of rated voltage	
	Leakage current	The initial specified value or less
	Percentage of capacitance change	Within ±20% of initial value
	Tangent of the loss angle	150% or less of the initial specified value
	E.S.R. change	200% or less of the initial specified value
Failure rate	0.5% per 1000 hours maximum (Confidence level 60% at 105°C)	

*Note : If any doubt arises, measure the leakage current after following voltage application treatment.
Voltage application treatment : DC rated voltage are applied to the capacitors for 120 minutes at 105°C.

Outline Drawing

Unit : mm

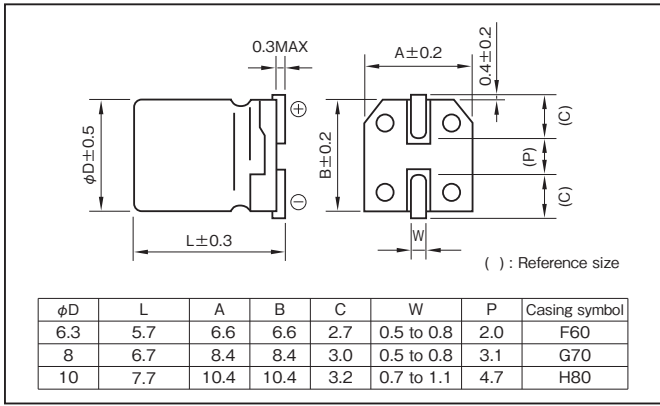

Part numbering system (example : 4V151 M F60 E)

PVH	4	V	151	M	F60	E	
Series code	Rated voltage symbol	Rated capacitance symbol	Capacitance tolerance symbol	Casing symbol	Taping symbol		

- Soldering conditions are described on page 13.
- Land pattern size are described on page 11.
- The taping specifications are described on page 14.

Aluminum Electrolytic Capacitors With Conductive Polymer Solid Electrolyte

Standard Ratings

Rated voltage (V)	Item	2.5			4			6.3			10			16		
		Case	ESR	Rated ripple current	Case	ESR	Rated ripple current	Case	ESR	Rated ripple current	Case	ESR	Rated ripple current	Case	ESR	Rated ripple current
		φD×L (mm)	(mΩ max.)	(mA rms)	φD×L (mm)	(mΩ max.)	(mA rms)	φD×L (mm)	(mΩ max.)	(mA rms)	φD×L (mm)	(mΩ max.)	(mA rms)	φD×L (mm)	(mΩ max.)	(mA rms)
33	—	—	—	—	—	—	—	—	—	—	—	—	6.3×5.7	37	2050	
39	—	—	—	—	—	—	—	—	—	—	—	—	6.3×5.7	37	2050	
47	—	—	—	—	—	—	—	—	—	—	6.3×5.7	31	2250	6.3×5.7	37	2050
56	—	—	—	—	—	—	—	—	—	—	6.3×5.7	31	2250	—	—	—
68	—	—	—	—	—	—	—	6.3×5.7	27	2400	—	—	—	—	—	—
82	—	—	—	—	—	—	—	6.3×5.7	27	2400	—	—	—	8×6.7	30	2700
100	—	—	—	6.3×5.7	26	2450	6.3×5.7	27	2400	8×6.7	27	2800	8×6.7	30	2700	
120	—	—	—	—	—	—	6.3×5.7	27	2400	8×6.7	27	2800	—	—	—	
150	—	—	—	6.3×5.7	26	2450	8×6.7	25	3020	8×6.7	27	2800	10×7.7	26	3430	
180	—	—	—	—	—	—	—	—	—	—	—	—	10×7.7	26	3430	
220	6.3×5.7	25	2500	8×6.7	25	3020	8×6.7	25	3020	10×7.7	24	3770	—	—	—	
270	—	—	—	—	—	—	—	—	—	10×7.7	24	3770	—	—	—	
330	8×6.7	23	3100	8×6.7	25	3020	10×7.7	20	4130	10×7.7	24	3770	—	—	—	
470	8×6.7	23	3100	10×7.7	20	4130	10×7.7	20	4130	—	—	—	—	—	—	
560	8×6.7	23	3100	—	—	—	—	—	—	—	—	—	—	—	—	
680	—	—	—	10×7.7	20	4130	—	—	—	—	—	—	—	—	—	
1000	10×7.7	19	4240	—	—	—	—	—	—	—	—	—	—	—	—	

Aluminum Electrolytic Capacitors
With Conductive Polymer Solid
Electrolyte

Rated voltage (V)	Item	20			25			35		
		Case	ESR	Rated ripple current	Case	ESR	Rated ripple current	Case	ESR	Rated ripple current
		φD×L (mm)	(mΩ max.)	(mA rms)	φD×L (mm)	(mΩ max.)	(mA rms)	φD×L (mm)	(mΩ max.)	(mA rms)
10	—	—	—	6.3×5.7	65	1500	8×6.7	200	750	
22	6.3×5.7	50	1650	8×6.7	50	1800	10×7.7	150	1000	
33	8×6.7	45	2000	10×7.7	45	2100	—	—	—	
39	8×6.7	45	2000	10×7.7	45	2100	—	—	—	
47	8×6.7	45	2000	—	—	—	—	—	—	
82	10×7.7	40	2500	—	—	—	—	—	—	

(Note) Rated ripple current : 105°C, 100kHz ; E.S.R. : 20°C, 100kHz

Chip Type GREEN CAP SMD Low ESR 125°C 1000hours Anti-cleaning solvent

- Super low E.S.R. and high ripple current are realized.
- Guaranteed 125°C, 1000 hours.

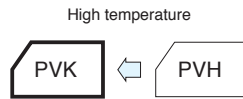
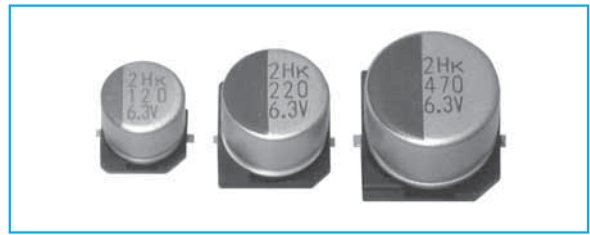

Specifications

Item	Performance	
Category temperature range (°C)	-55 to +125	
Tolerance at rated capacitance (%)	±20 (20°C, 120Hz)	
Leakage current (μA) *Note	Rated voltage (V)	2.5 to 20
	Leakage current (μA)	Less than 0.2 CV
		25,35
		Less than 0.5 CV
	C : Rated capacitance (μF) ; V : Rated voltage (V) (20°C)	
Tangent of the loss angle (tanδ)	Less than 0.12 (20°C, 120Hz)	
Characteristics at high and low temperature	Impedance ratio (max.)	
	Z-25°C/Z+20°C : 1.15 Z-55°C/Z+20°C : 1.25 (100kHz)	
Endurance (125°C) (Applied ripple current)	Test time	1000 hours
	Leakage current	The initial specified value or less
	Percentage of capacitance change	Within ±20% of initial value
	Tangent of the loss angle	150% or less of the initial specified value
	E.S.R. change	150% or less of the initial specified value
Bias Humidity 60°C, 90 to 95%RH	Test time	500 hours
	Leakage current	The initial specified value or less
	Percentage of capacitance change	Within ±20% of initial value
	Tangent of the loss angle	150% or less of the initial specified value
	E.S.R. change	150% or less of the initial specified value
Characteristics of applied surge voltage	The capacitors shall be subject to 1000 cycles each consisting of charge with the surge voltage specified at 125°C for 30 seconds through a protective resistor (Rc=1kΩ) in 6 minutes per cycle. Surge voltage : 1.15 times of rated voltage	
	Leakage current	The initial specified value or less
	Percentage of capacitance change	Within ±20% of initial value
	Tangent of the loss angle	150% or less of the initial specified value
	E.S.R. change	150% or less of the initial specified value
Failure rate	0.5% per 1000 hours maximum (Confidence level 60% at 125°C)	

*Note : If any doubt arises, measure the leakage current after following voltage application treatment.
Voltage application treatment : DC rated voltage are applied to the capacitors for 120 minutes at 125°C.

Outline Drawing

Unit : mm

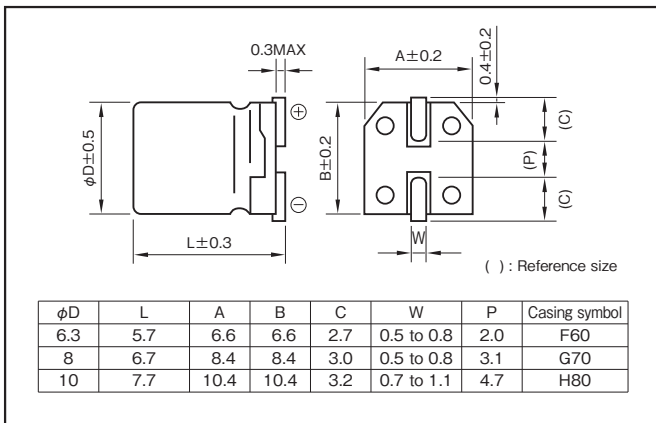

- Soldering conditions are described on page 13.
- Land pattern size are described on page 11.
- The taping specifications are described on page 14.

Part numbering system (example : 4V150μF)

PVK	—	4	V	151	M	E60	E	—	□
Series code		Rated voltage symbol		Rated capacitance symbol	Capacitance tolerance symbol	Casing symbol			Taping symbol

Standard Ratings

Rated capacitance (μF)	2.5			4			6.3			10			16		
	Item			Case			Case			Case			Case		
	Case	ESR	Rated ripple current	Case	ESR	Rated ripple current	Case	ESR	Rated ripple current	Case	ESR	Rated ripple current	Case	ESR	Rated ripple current
	φD×L (mm)	(mΩ max.)	(mA rms)	φD×L (mm)	(mΩ max.)	(mA rms)	φD×L (mm)	(mΩ max.)	(mA rms)	φD×L (mm)	(mΩ max.)	(mA rms)	φD×L (mm)	(mΩ max.)	(mA rms)
33	—	—	—	—	—	—	—	—	—	—	—	—	6.3×5.7	37	590
39	—	—	—	—	—	—	—	—	—	—	—	—	6.3×5.7	37	590
47	—	—	—	—	—	—	—	—	—	6.3×5.7	31	680	6.3×5.7	37	590
56	—	—	—	—	—	—	—	—	—	6.3×5.7	31	680	—	—	—
68	—	—	—	—	—	—	6.3×5.7	27	720	—	—	—	—	—	—
82	—	—	—	—	—	—	6.3×5.7	27	720	—	—	—	8×6.7	30	830
100	—	—	—	6.3×5.7	26	770	6.3×5.7	27	720	8×6.7	27	880	8×6.7	30	830
120	—	—	—	—	—	—	6.3×5.7	27	720	8×6.7	27	880	—	—	—
150	—	—	—	6.3×5.7	26	770	8×6.7	25	960	8×6.7	27	880	10×7.7	26	930
180	—	—	—	—	—	—	—	—	—	—	—	—	10×7.7	26	930
220	6.3×5.7	25	770	8×6.7	25	960	8×6.7	25	960	10×7.7	24	1010	—	—	—
270	—	—	—	—	—	—	—	—	—	10×7.7	24	1010	—	—	—
330	8×6.7	23	960	8×6.7	25	960	10×7.7	20	1100	10×7.7	24	1010	—	—	—
470	8×6.7	23	960	10×7.7	20	1100	10×7.7	20	1100	—	—	—	—	—	—
560	8×6.7	23	960	—	—	—	—	—	—	—	—	—	—	—	—
680	—	—	—	10×7.7	20	1100	—	—	—	—	—	—	—	—	—
1000	10×7.7	19	1100	—	—	—	—	—	—	—	—	—	—	—	—

Aluminum Electrolytic Capacitors
With Conductive Polymer Solid
Electrolyte

Rated capacitance (μF)	20			25		
	Item			Case		
	Case	ESR	Rated ripple current	Case	ESR	Rated ripple current
	φD×L (mm)	(mΩ max.)	(mA rms)	φD×L (mm)	(mΩ max.)	(mA rms)
10	—	—	—	6.3×5.7	65	500
22	6.3×5.7	50	590	8×6.7	50	600
39	8×6.7	45	780	10×7.7	45	700
47	8×6.7	45	780	—	—	—
82	10×7.7	40	820	—	—	—

(Note) Rated ripple current : 125°C, 100kHz ; ESR : 20°C, 100kHz

Chip Type GREEN CAP SMD Low ESR 105°C 2000hours Anti-cleaning solvent

- High voltage (to 63V)
- High CV and low E.S.R and High ripple Current are realized
- Guaranteed 105°C, 2000 hours.

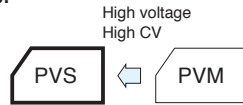

Specifications

Item	Performance	
Category temperature range (°C)	-55 to +105	
Tolerance at rated capacitance (%)	±20 (20°C,120Hz)	
Leakage current (μA) *Note C : Rated capacitance (μF) ; V : Rated voltage (V)	Rated voltage (V) 35 to 63	
	Leakage current (μA) Less than 0.5 CV (20°C)	
Tangent of the loss angle (tanδ)	Less than 0.12 (20°C,120Hz)	
Characteristics at high and low temperature	Impedance ratio (max.)	
	Z-25°C/Z+20°C : 1.15 Z-55°C/Z+20°C : 1.25 (100kHz)	
Endurance (105°C) (Applied ripple current)	Test time 2000 hours	
	Leakage current The initial specified value or less	
	Percentage of capacitance change Within ±20% of initial value	
	Tangent of the loss angle 150% or less of the initial specified value	
	E.S.R. change 150% or less of the initial specified value	
Bias Humidity 60°C, 90 to 95%RH	Test time 500 hours	
	Leakage current The initial specified value or less	
	Percentage of capacitance change Within ±20% of initial value	
	Tangent of the loss angle 150% or less of the initial specified value	
	E.S.R. change 150% or less of the initial specified value	
Characteristics of applied surge voltage	The capacitors shall be subject to 1000 cycles each consisting of charge with the surge voltage specified at 105°C for 30 seconds through a protective resistor (Rc=1kΩ) in 6 minutes per cycle. Surge voltage : 1.15 times of rated voltage	
	Leakage current	The initial specified value or less
	Percentage of capacitance change	Within ±20% of initial value
	Tangent of the loss angle	150% or less of the initial specified value
	E.S.R. change	150% or less of the initial specified value
Failure rate	0.5% per 1000 hours maximum (Confidence level 60% at 105°C)	

*Note : If any doubt arises, measure the leakage current after following voltage application treatment.
Voltage application treatment : DC rated voltage are applied to the capacitors for 120 minutes at 105°C.

Outline Drawing

Unit : mm

φD	L	A	B	C	W	P	Casing symbol
6.3	5.7	6.6	6.6	2.7	0.5 to 0.8	2.0	F60
8	6.7	8.4	8.4	3.0	0.5 to 0.8	3.1	G70
10	7.7	10.4	10.4	3.2	0.7 to 1.1	4.7	H80

() : Reference size

- Soldering conditions are described on page 13.
- Land pattern size are described on page 11.
- The taping specifications are described on page 14.

Part numbering system (example : 35V100μF)

PVS	—	35	V	101	M	H80	—	□
Series code		Rated voltage symbol		Rated capacitance symbol	Capacitance tolerance symbol	Casing symbol		Taping symbol

Aluminum Electrolytic Capacitors With Conductive Polymer Solid Electrolyte

Standard Ratings

Rated voltage (V) Rated capacitance (μF)	Item	35			50			63		
		Case	ESR	Rated ripple current	Case	ESR	Rated ripple current	Case	ESR	Rated ripple current
		φD×L (mm)	(mΩ max.)	(mA _{rms})	φD×L (mm)	(mΩ max.)	(mA _{rms})	φD×L (mm)	(mΩ max.)	(mA _{rms})
18	—	—	—	—	—	—	8×6.7	55	2300	
22	—	—	—	—	—	—	—	—	—	
27	6.3×5.7	40	2600	8×6.7	45	2600	—	—	—	
33	—	—	—	—	—	—	—	—	—	
39	—	—	—	—	—	—	10×7.7	50	3000	
47	8×6.7	35	2800	—	—	—	—	—	—	
56	—	—	—	10×7.7	40	3200	—	—	—	
68	—	—	—	—	—	—	—	—	—	
82	—	—	—	—	—	—	—	—	—	
100	10×7.7	30	3500	—	—	—	—	—	—	

(Note) Rated ripple current : 105°C, 100kHz ; ESR. : 20°C, 100kHz

Aluminum Electrolytic Capacitors
With Conductive Polymer Solid
Electrolyte

Radial lead Type

- GREEN CAP
- Low ESR
- 105°C
2000hours
- Anti-cleaning solvent

- Low E.S.R. and high ripple current are realized.
- Guaranteed 105°C, 2000 hours.

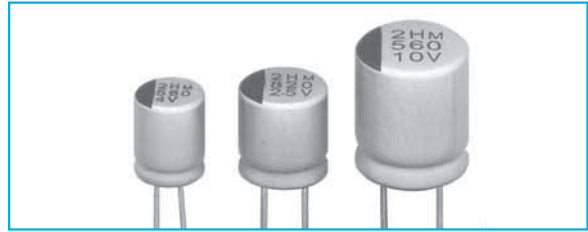

Specifications

Item	Performance	
Category temperature range (°C)	-55 to +105	
Tolerance at rated capacitance (%)	±20 (20°C, 120Hz)	
Leakage current (μA) *Note	Less than 0.2CV or 500 whichever is larger (after 2 minutes) C : Rated capacitance (μF) ; V : Rated voltage (V) (20°C)	
Tangent of the loss angle (tanδ)	Less than 0.12 (20°C, 120Hz)	
Characteristics at high and low temperature	Impedance ratio (max.) Z-55°C / Z+20°C : 1.50 (100kHz)	
Endurance (105°C) (Applied ripple current)	Test time	2000 hours
	Leakage current	The initial specified value or less
	Percentage of capacitance change	Within ±20% of initial value
	Tangent of the loss angle	150% or less of the initial specified value
	E.S.R. change	200% or less of the initial specified value
Damp heat, steady state (humidity) 60°C, 90 to 95%RH	Test time	500 hours
	Leakage current	The initial specified value or less
	Percentage of capacitance change	Within ±20% of initial value
	Tangent of the loss angle	150% or less of the initial specified value
	E.S.R. change	200% or less of the initial specified value
Characteristics of applied surge voltage	The capacitors shall be subject to 1000 cycles each consisting of charge with the surge voltage specified at 105°C for 30 seconds through a protective resistor (Rc=1kΩ) in 6 minutes per cycle. Surge voltage : 1.15 times of rated voltage	
	Leakage current	The initial specified value or less
	Percentage of capacitance change	Within ±20% of initial value
	Tangent of the loss angle	150% or less of the initial specified value
	E.S.R. change	200% or less of the initial specified value
Failure rate	0.5% per 1000 hours maximum (Confidence level 60% at 105°C)	

*Note : If any doubt arises, measure the leakage current after following voltage application treatment.
Voltage application treatment : DC rated voltage are applied to the capacitors for 120 minutes at 105°C.

Outline Drawing

Unit : mm

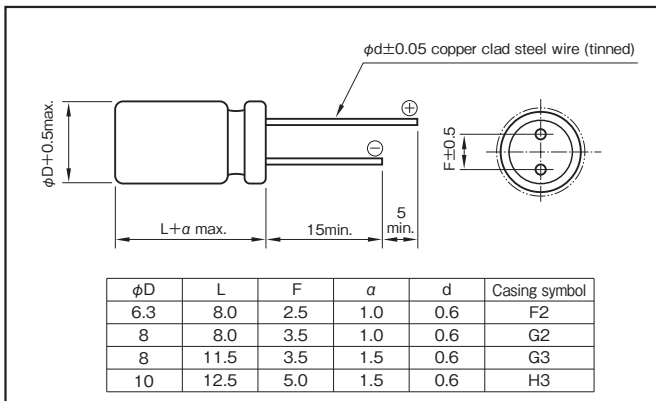

- Soldering conditions are described on page 12.
- The taping specifications are described on page 17.

Part numbering system (example : 4V561M F2)						
PRM	4	V	561	M	F2	
Series code	Rated voltage symbol	Rated capacitance symbol	Capacitance tolerance symbol	Casing symbol	Optional symbol	Taping symbol

NOTE

Design, Specifications are subject to change without notice.
Ask factory for technical specifications before purchase and/or use.

Standard Ratings

Rated voltage (V)	Item	2.5				4				6.3				10			
		Case	tan δ	ESR (mΩ max.)	Rated ripple current (mA rms)	Case	tan δ	ESR (mΩ max.)	Rated ripple current (mA rms)	Case	tan δ	ESR (mΩ max.)	Rated ripple current (mA rms)	Case	tan δ	ESR (mΩ max.)	Rated ripple current (mA rms)
		φD×L (mm)				φD×L (mm)				φD×L (mm)				φD×L (mm)			
100	—	—	—	—	—	—	—	—	—	—	—	—	—	—	—	—	—
150	—	—	—	—	—	—	—	—	—	—	—	—	—	—	—	—	—
180	—	—	—	—	—	—	—	—	—	—	—	—	—	—	—	—	—
220	—	—	—	—	—	—	—	—	—	—	—	—	—	6.3×8.0	0.10	10	4680
270	—	—	—	—	—	—	—	—	—	—	—	—	—	6.3×8.0	0.10	10	4680
330	6.3×8.0	0.10	7	5600	—	—	—	—	6.3×8.0	0.10	10	4680	8×8.0	0.08	10	5000	
390	—	—	—	—	—	—	—	—	—	—	—	—	8×8.0	0.08	10	5000	
470	6.3×8.0	0.10	7	5600	—	—	—	—	6.3×8.0	0.10	7	5600	8×8.0	0.08	8	5700	
560	6.3×8.0	0.10	7	5600	6.3×8.0	0.10	7	5600	8×8.0	0.08	7	6100	10×12.5	0.12	12	5300	
680	—	—	—	—	8×8.0	0.08	6	6100	8×8.0	0.08	8	5700	—	—	—	—	
820	8×8.0	0.08	6	6100	8×8.0	0.08	6	6100	10×12.5	0.12	10	5500	—	—	—	—	
1000	8×8.0	0.08	6	6100	10×12.5	0.12	8	5500	10×12.5	0.12	10	5500	—	—	—	—	
1200	10×12.5	0.12	8	5500	10×12.5	0.12	8	5500	—	—	—	—	—	—	—	—	
1500	10×12.5	0.12	8	5500	—	—	—	—	—	—	—	—	—	—	—	—	

(Note) Rated ripple current : 105°C , 100kHz ; ESR : 20°C , 100kHz

Aluminum Electrolytic Capacitors
With Conductive Polymer Solid
Electrolyte

MEMO

Aluminum Electrolytic Capacitors

■ Cautions for Using Aluminum Electrolytic Capacitors

Please read product specifications before using ELNA products.

The following cautions should be observed when using our aluminum electrolytic capacitors to assure their maximum stability and performance. When your application design conditions or operating conditions exceed the limit of the product specification, please contact us. If used under conditions beyond the limit of our specifications, it may cause defects such as short circuit, open circuit, leakage, explosion or combustion.

■ Cautions for usage

1. DC electrolytic capacitors are polarized.

- If used with a wrong polarity, it creates an abnormal current resulting in a short circuit or damage to itself. Use DC bipolar electrolytic capacitors for use with uncertain or unknown polarity. DC capacitors cannot be used in AC circuits.

2. Use within the rated voltage.

- If a voltage exceeding the rated voltage is applied, it may cause characteristic deterioration or damage due to the increased leakage current.
- When ripple current is loaded, make sure that the peak value of the ripple voltage does not exceed the rated voltage.

3. Using for power supply circuit.

- While aluminum electrolytic capacitors are operated electrolyte liquid inside dries up and E.S.R. (Equivalent Series Resistance) of the capacitor increases. In case operated longer than rated life time, the capacitance much decreases, tangent of loss angle and E.S.R. much increases. Therefore for some case the sum of bias direct voltage and the peak of ripple voltage is over the rated voltage of the capacitor.
- For any type of circuit, in case the sum of bias direct voltage and the peak of ripple voltage is over the rated voltage of the capacitors or in case the minimum voltage is lower than 0 (zero) volt, the voltage control for the capacitors shall be provided.

4. Do not use in a circuit which requires rapid charging or discharging.

- If used in a circuit requiring rapid charging or discharging, it may cause characteristic deterioration or damage to itself due to the heat generated inside the capacitor. In such cases, contact us for our rapid charging/discharging capacitors.

5. Use within the rated ripple current.

- If applied ripple current exceeds rated ripple current, the life of the capacitor may be shortened, or in an extreme case it gets destroyed due to its internal heat. Use high-ripple type capacitors for such circuits.

6. Changes in characteristics due to operating temperature.

- The characteristics of an electrolytic capacitor will change with a change in the temperature. Such changes are temporary and the original characteristics will be restored at the original temperature (if

the characteristics are not deteriorated by remaining at a high temperature for a long time). If used at a temperature exceeding the guaranteed temperature range, the capacitor may be damaged due to the increased leakage current. Pay attention to the capacitor temperature being affected by the ambient temperature of the unit, the temperature inside the appliance, the heat radiated by another hot component in the unit and the heat inside the capacitor itself due to the ripple current.

- (1)The electrostatic capacitance is normally shown as the value at 20°C-120Hz. It increases as the temperature raises and decreases as it lowers.
- (2)The tangent of loss angle ($\tan\delta$) is normally shown as the value at 20°C-120Hz. It decreases as the ambient temperature gets high and increases as it gets low.
- (3)The leakage current increases as the temperature gets high and decreases as it gets low.

7. Changes in the characteristics due to frequency.

- The characteristics of an electrolytic capacitor will change according to the change in the operating frequency.
 - (1)The electrostatic capacity is normally shown as the value at 20°C-120Hz. It decreases as the frequency increases.
 - (2)The tangent of loss angle ($\tan\delta$) is normally shown as the value at 20°C-120Hz. It increases as the frequency gets high.
 - (3)The impedance is normally shown as the value at 100kHz 20°C. It increases as the frequency lowers.

8. Aluminum electrolytic capacitor life.

- The life of an aluminum electrolytic capacitor terminates when it fails due to the deterioration in its electronic characteristics. Temperature and the ripple current since they especially affect the life. See chart on page.

9. Changes in aluminum electrolytic capacitors during storage.

- After storage for a long period, whether unused of mounted on the appliance, the leakage current of an aluminum electrolytic capacitor will increase. This tendency is more prominent when the ambient temperature is high. If a capacitor has been stored for more than 2 years under normal temperature (shorter if high temperature) and it shows increased leakage current, a treatment by voltage application is recommended. Addition of a protective circuit in

the design of the appliance is also recommended, considering the effect of the initial increased current.

10. Insulation between the capacitor case and the cathode terminal.

- The capacitor case and the cathode terminal are connected through the electrolyte which has uncertain resistance. If a complete insulation of the case is necessary, add an insulator at assembly.

11. External sleeve.

- During a preheating or a hardening of mounting adhesive may cause a sleeve cracked. The capacitors are usually sleeved with poly vinyl chloride or poly ethylene terephthalate for the indication purpose only. Please do not consider it as an insulation.

12. Fumigation Process

- When exporting electronic equipment abroad, fumigation process may be performed on wooden packaging material with a halogen (compound) gas such as methyl bromide. Exercise care as this halogen gas may corrode capacitors. Also, use caution to epidemic preventive agent as corrosive component such as halogen may be contained.

13. Specific Operating Environments

- Capacitors may corrode when stored or used in a place filled with acidic toxic gases (such as hydrogen sulfide, sulfurous acid, nitrous acid, chlorine, bromine, methyl bromide, etc.) If capacitors are used or stored in such environments, please let us know.

14. Use at a high altitude

- The use of capacitors at high altitudes such as on an airplane causes a large difference between the internal pressure of the capacitors and the atmospheric pressure. However, there is no problem in use under atmospheric pressure up to about an altitude of 10,000 meters. Please check the operation of electronic equipment at the operating environmental temperature because the temperature lowers with increased altitude. If the condition is severe like space, please contact us.

15. Hole pitch adjustment of the PCB to the capacitors.

- Set the hole pitch of the PCB to the lead pitch (the "F" distance in the catalog) of the capacitor. Be careful since a short circuit, a cut or an increase in the leakage current etc. may be caused by the stress given to the lead wire terminals due to the difference between the hole pitch and the lead pitch.

16. Capacitors with pressure valves.

- A part of the capacitor case is made thin to have

the function as the pressure valve in order to prevent explosion due to the rise of inside pressure when a reverse or excessive voltage is applied to the capacitor. Once it has worked as a valve, the whole capacitor needs to be replaced since the valve will not restore.

- When you use a capacitor with pressure valve, provide certain space above the pressure valve as below to prevent an interference when it works as a valve.

Diameter of the capacitor (mm)	18 to less	20 to 40
Required space above the valve (mm)	2.0	3.0

17. Double-sided PCB's

- When you use electrolytic capacitors on a double sided PCB, be careful not to have the circuit pattern run under where the capacitor is mounted. Otherwise it may cause a short circuit on the PCB depending on the condition of mounting.

18. Regarding to connection of capacitors

- Aluminum electrolytic capacitor has electrolyte liquid so that the most portion of electric loss characteristics came from E.S.R(Equivalent Series Resistance) of electrolyte liquid. Therefore the capacitor is an electronic devise which can flow high ripple current in case the temperature increases and it decreases E.S.R.

In case connecting two capacitors or more, E.S.R. of the capacitors is close to the resistance of the circuit. Therefore in case current is unbalanced and some capacitors has high ripple current, temperature increase, it makes more high current and finally it is over the rated ripple current.

For parallel connection of capacitors the proper design of electric circuit such as balancing of each capacitors resistance or control of total ripple current shall be provided to avoid excess ripple current and voltage.

- When two or more capacitors are arranged in series, the voltage given to each capacitors shall be kept below the rated voltage level, by also giving consideration to the balance of the voltage impressed on the capacitors. Further, partial pressure resistor which considers leakage current shall be provided parallel to each condenser not to have over-voltage impressed on. Balance resistance are explained on p.106 of our Catalog.

■Cautions for Mounting

1. Cautions for mounting.

- Check the ratings (electrostatic capacitance and rated voltage) of the capacitor before mounting.
- Check the polarity of the capacitor to the chassis.
- Do not drop the capacitor to the floor. Do not use

the dropped capacitor.

- Do not deform the capacitor for mounting.

2. Do not apply excessive pressure to the capacitor, its terminals or lead wires.

- Make sure that the contact path of the capacitor meets the hole pitch of the PCB before mounting.
- Transient recovery voltage may be generated in the capacitor due to dielectric absorption. If required, this voltage can be discharged with a resistor with a value of about 1 kΩ.
- A PCB self-standing (snap-in) type capacitor should be pushed to the end (till there is no space) to the PCB for mounting.
- Do not set the automatic insertion machine to clinch the capacitor lead wires too strong.
- Pay attention to the impact given by the component receptacles of the automatic insertion/mounting machines and the product checker, and from the centering operation.

3. Soldering.

- Do not dip the capacitor into melted solder.
- The soldering conditions
Chip type : Please refer to 11 page.
small and large type : 260°C, 10 s (max.)
The preliminary heating and other conditions described in the catalog or product specifications.
- Do not flux other part than the terminals.
- If there is a direct contact between the sleeve of the capacitor and the printed circuit pattern or a metal part of another component such as a lead wire, it may cause shrinkage or crack.
- When you use the capacitor with its sleeve touching directly to the PCB, excessive solder temperature or excessive soldering time may cause the sleeve to shrink or crack during the heat.
- If the application is for extended use, understand and manage the soldering characteristics to avoid abnormal current caused by a contact failure between the capacitor and the PCB.

4. Handling after soldering.

- After soldering, do not tilt, push down or twist the capacitor.
- After soldering, do not hold the capacitor as a handle to carry the PCB.
- After soldering, do not hit the capacitor with any obstacle. If PCB's are piled up for storage, the capacitor should not touch another PCB or component.

5. Cleaning after Soldering

- Recommended cleaning method
(1)cleaning solutions:
(a) CLEANTHROUGH 710M, 750H, 750L
(b) PINEALPHA ST-100S
(c) Techno Care FRW-4~17
(d) Isopropyl alcohol (2-propanol)

(2)Cleaning conditions:

- (a) The temperature of cleaning solution shall be less than 60°C.
- (b) Use immersion or ultrasonic waves within two minutes.
- (c) After cleaning, capacitors and PCB's shall thoroughly be rinsed and dried with hot blast for more than 10 minutes. The temperature of such breeze should be less than the upper category temperature.
- (d) After cleaning, do not keep capacitors in cleaning solution atmosphere or airtight containers.
- During cleaning, control the cleaning solution against contamination.

6. Fixing adhesives and coating materials.

- Do not use fixing adhesive or coating material containing halogen-based solvent.
- Before applying the fixing adhesive or the coating material, make sure that there is no remaining flux or stains between the PCB and the sealed part of the capacitor.
- Before applying the fixing adhesive or the coating material, make sure that the detergent etc. has dried up.
- Do not cover the whole surface of the sealed part (terminal side) of the capacitor with the fixing adhesive or the coating material.
- Observe the description in the catalog or the product specifications concerning the thermal stiffening conditions of the fixing adhesive or the coating material. (If there is no such description, contact us.) When both discrete and SMT components are on the same PCB, the fixing material for the SMT components may cause crack, tear or shrinkage on the external sleeve depending on the thermal stiffening condition.
- Recommended fixing adhesives and coating materials
Fixing adhesives : Cemedine 1500, Diabond DN83K, Bond G103
Coating materials : Taffy TF1159, HumiSeal 1B66NS, 1A27NS

■ Other Cautions

1. Do not touch capacitor terminals with bare hands.

You may get electric shock or your hand may be burnt. Discharge it with a 1 KΩ resistance before use if necessary.

2. Do not short the capacitor terminals with a conductor.

Do not spill conductive solution including acid or alkaline solution on the capacitor.

3. Periodical inspections should be established for the capacitors used in industrial appliances.

- The following items should be checked:

NOTE

Design, Specifications are subject to change without notice.
Ask factory for technical specifications before purchase and/or use.

(1) Appearance : Check if there is any open valve or leakage.

(2) Electronic performance : Check the leakage current, the electrostatic capacitance, the tangent of loss angle and other items described in the catalog or the product specifications.

4. Take the following measures in case of emergency.

- If you see gas coming out of the capacitor valve when the set is in operation, turn off the power switch of the unit or unplug the power cord from the outlet.
- Keep your face away from the capacitor pressure valve, since the high temperature gas at over 100°C bursts out when the valve works. If the gas gets into your eyes or your mouth, wash your eyes or your mouth. Do not ingest the capacitor electrolyte. If the electrolyte gets on your skin, wash it out with soap.

5. Storing conditions.

- Avoid high temperature or high humidity when storing capacitors. Keep the storing temperature at 5°C to 35°C and the relative humidity not more than 75%.
- The leakage current of an aluminum electrolytic capacitor tends to increase when stored for a long time. This tendency becomes more prominent if the ambient temperature is high. The leakage current will be decreased by voltage application. If necessary, treatment by voltage application should

be made on the capacitors which have been stored for a long period (more than 2 years after production).

- Do not store capacitors at a place where there is a possibility that they may get water, salt or oil spill.
- Do not store capacitors at a place where the air contains dense hazardous gas (hydrogen sulfide, sulfurous acid, nitrous acid, chlorine, ammonia, etc.).
- Fumigation treatment with toxic gas covering the whole wooden container frames as moth proofing during shipment may leave residual toxic gas.
- Do not store capacitors at a place where it gets ultraviolet or radioactive rays.

6. Disposing of capacitors.

- Punch a hole or crush the capacitors (to prevent explosion) before incineration at approved facility.
- If they are not to be incinerated, bring them to a professional industrial waste disposal company.

7. Other notes.

- Please refer to the following literature for anything not described in the product specifications or the catalog.

(Technical report of Japan Electronics and Information Technology Industries Association, EIAJ RCR-2367C “Guideline of notabilia for fixed aluminum electrolytic capacitors for use in electronic equipment”)

MEMO

Chip Type Aluminum Electrolytic Capacitors

ChipType Standard Capacitors (height:5.5mm)

GREEN CAP

SMD

Anti-cleaning solvent

- Compatible with surface mounting for 5.5mm high capacitors.
- Supplied with carrier taping.
- Guarantees 2000 hours at 85°C.

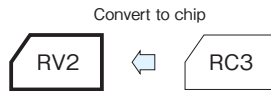

Marking color : Black print

Specifications

Item	Performance									
Category temperature range (°C)	-40 to +85									
Tolerance at rated capacitance (%)	±20 (20°C,120Hz)									
Leakage current (μA)	Less than 0.01CV or 3 whichever is larger (after 2 minutes) C : Rated capacitance (μF) ; V : Rated voltage (V) (20°C)									
Tangent of loss angle (tanδ)	Rated voltage (V)									
	tanδ (max.)		4	6.3	10	16	25	35	50	
Characteristics at high and low temperature	Impedance ratio (max.)	φ3	Z-25°C/Z+20°C	4	6.3	10	16	25	35	50
			Z-40°C/Z+20°C	7	4	3	2	2	2	2
	φ4 to φ6.3	Z-25°C/Z+20°C	7	3	3	2	2	2	2	
		Z-40°C/Z+20°C	15	8	5	4	3	3	3	
Endurance (85°C) (Applied ripple current)	Test time		2000 hours (φ3 : 1000 hours)							
	Leakage current		The initial specified value or less							
	Percentage of capacitance change		Within ±20% of initial value (4WV : ±30%)							
	Tangent of the loss angle		200% or less of the initial specified value (4WV : 300%)							
Shelf life (85°C)	Test time : 1000hours ; other items are the same as those for the endurance. Voltage application treatment : According to JIS C5101-1									
Applicable standards	JIS C5101-1 1998, -18 1999 (IEC 60384-1 1992, -18 1993)									

Outline Drawing

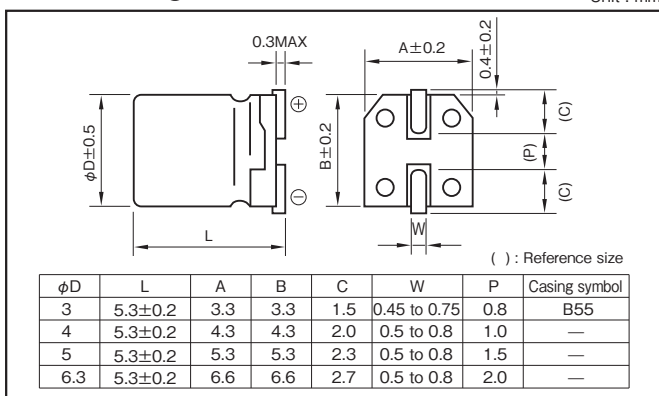

Coefficient of Frequency for Rated Ripple Current

Rated voltage (V)	Frequency (Hz)			
	50 · 60	120	1k	10k · 100k
4 to 16	0.80	1	1.15	1.25
25 to 35	0.80	1	1.25	1.40
50	0.80	1	1.35	1.50

Part numbering system

• φ3 (example : 16V10μF)

RV2 — 16 V 100 M B55 U — □

Series code Rated voltage symbol Rated capacitance symbol Capacitance tolerance symbol Casing symbol Taping symbol

• φ4 to φ6.3 (example : 16V47μF)

RV2 — 16 V 470 M * U — □

Series code Rated voltage symbol Rated capacitance symbol Capacitance tolerance symbol Additional symbol Taping symbol

*Should add "S", when there is a black point in standard ratings.

- Soldering conditions are described on page 13. • Land pattern size are described on page 11.
- The taping specifications are described on page 14.

Standard Ratings

Rated capacitance (μF)	4				6.3				10				16				25				35				50			
	Case φD (mm)	Casing symbol	ESR (Ω)	Rated ripple current (mA)	Case φD (mm)	Casing symbol	ESR (Ω)	Rated ripple current (mA)	Case φD (mm)	Casing symbol	ESR (Ω)	Rated ripple current (mA)	Case φD (mm)	Casing symbol	ESR (Ω)	Rated ripple current (mA)	Case φD (mm)	Casing symbol	ESR (Ω)	Rated ripple current (mA)	Case φD (mm)	Casing symbol	ESR (Ω)	Rated ripple current (mA)				
0.1	—	—	—	—	—	—	—	—	—	—	—	—	—	—	—	—	—	—	—	—	—	—	—	—				
0.22	—	—	—	—	—	—	—	—	—	—	—	—	—	—	—	—	—	—	—	—	—	—	—	—				
0.33	—	—	—	—	—	—	—	—	—	—	—	—	—	—	—	—	—	—	—	—	—	—	—	—				
0.47	—	—	—	—	—	—	—	—	—	—	—	—	—	—	—	—	—	—	—	—	—	—	—	—				
1	—	—	—	—	—	—	—	—	—	—	—	—	—	—	—	—	—	—	—	—	—	—	—	—				
2.2	—	—	—	—	—	—	—	—	—	—	—	—	—	—	—	—	3	B55	106	8	4	—	—	75	15			
3.3	—	—	—	—	—	—	—	—	—	—	—	—	—	—	—	—	3	B55	70	9	4	—	—	50	19			
4.7	—	—	—	—	—	—	—	—	—	—	—	—	—	—	—	—	3	B55	57	11	4	—	—	42	20			
10	—	—	—	—	—	—	—	—	—	—	—	—	—	—	—	—	4	—	49	19	—	—	—	—	—			
22	3	B55	32	14	4	—	21	31	5	—	18	39	5	—	15	44	6.3	—	11	55	6.3	—	9.1	59	—	—		
33	4	—	21	31	5	—	14	44	5	—	12	48	6.3	—	10	63	6.3	—	7.0	67	—	—	—	—	—	—		
47	4	—	15	37	5	—	10	52	6.3	—	8.5	67	6.3	—	7.1	75	—	—	—	—	—	—	—	—	—	—		
100	5	—	7.0	63	6.3	—	5.0	89	6.3	—	4.0	98	6.3	—	3.3	103	—	—	—	—	—	—	—	—	—	—		
220	6.3	—	3.2	110	—	—	—	—	—	—	—	—	—	—	—	—	—	—	—	—	—	—	—	—	—			

(Note) Rated ripple current : 85°C, 120Hz ; ESR : 20°C, 120Hz

NOTE

Design, Specifications are subject to change without notice.
Ask factory for technical specifications before purchase and/or use.

Chip Type Large Capacitance Capacitors

GREEN CAP

SMD

Anti-cleaning solvent

- Compatible with surface mounting.
- Supplied with carrier taping.
- Guarantees 2000 hours at 85°C.

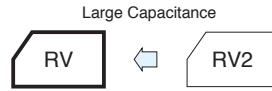

Marking color : Black print (φ8×6.5L)
White print on a brown sleeve (φ8×10L - φ12.5×13.5L)

Specifications

Item	Performance									
Category temperature range (°C)	-40 to +85									
Tolerance at rated capacitance (%)	±20 (20°C,120Hz)									
Leakage current (μA)	Less than 0.01CV or 3 whichever is larger (after 2 minutes) C : Rated capacitance (μF) ; V : Rated voltage (V) (20°C)									
Tangent of loss angle (tanδ)	Rated voltage (V)	6.3	10	16	25	35	50	63	100	
	tanδ (max.)	0.28	0.24	0.20	0.14	0.12	0.10	0.10	0.10	
Characteristics at high and low temperature	Rated voltage (V)	6.3	10	16	25	35	50	63	100	
	Impedance ratio (max.)	Z-25°C/Z+20°C	4	3	2	2	2	2	2	2
Endurance (85°C) (Applied ripple current)	Test time	2000 hours								
	Leakage current	The initial specified value or less								
	Percentage of capacitance change	Within ±20% of initial value								
	Tangent of the loss angle	200% or less of the initial specified value								
Shelf life (85°C)	Test time : 1000hours; other items are the same as those for the endurance. Voltage application treatment : According to JIS C5101-1									
Applicable standards	JIS C 5101-1 1998,-18 1999 (IEC 60384-1 1992, -18 1993)									

Outline Drawing

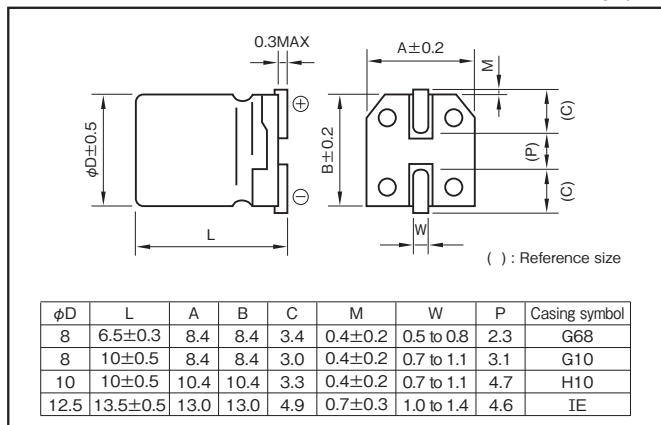

- Soldering conditions are described on page 13.
- Land pattern size are described on page 11.
- The taping specifications are described on page 14.

Coefficient of Frequency for Rated Ripple Current

Rated voltage (V)	Frequency (Hz)			
	50 · 60	120	1k	10k · 100k
6.3 to 16	0.80	1	1.15	1.25
25 to 35	0.80	1	1.25	1.40
50 to 63	0.80	1	1.35	1.50
100	0.70	1	1.35	1.50

Rated capacitance (μF)	Frequency (Hz)			
	120	1k	10k	100k
100 to 220	1	1.21	1.29	1.43
330 to 1000	1	1.16	1.23	1.25
1500 to 2200	1	1.06	1.11	1.11

Part numbering system

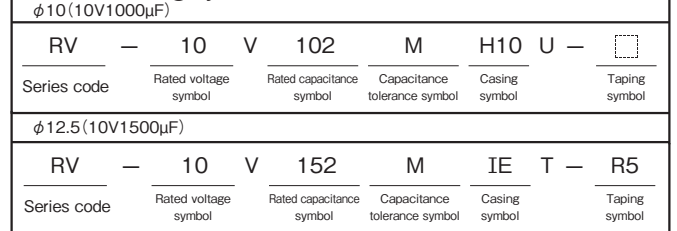

Standard Ratings

Rated voltage (V)	6.3			10			16			25			35			50			63			100				
	Case φD (mm)	Casing symbol	Rated ripple current (mA rms)	Case φD (mm)	Casing symbol	Rated ripple current (mA rms)	Case φD (mm)	Casing symbol	Rated ripple current (mA rms)	Case φD (mm)	Casing symbol	Rated ripple current (mA rms)	Case φD (mm)	Casing symbol	Rated ripple current (mA rms)	Case φD (mm)	Casing symbol	Rated ripple current (mA rms)	Case φD (mm)	Casing symbol	Rated ripple current (mA rms)	Case φD (mm)	Casing symbol	Rated ripple current (mA rms)		
10	—	—	—	—	—	—	—	—	—	—	—	—	—	—	—	—	—	—	—	—	—	—	—	—		
22	—	—	—	—	—	—	—	—	—	—	—	—	—	—	—	8×6.5	G68	155	8×10	G10	139	10×10	H10	189		
33	—	—	—	—	—	—	—	—	—	—	—	—	—	—	8×6.5	G68	155	8×6.5	G68	155	8×10	G10	139	10×10	H10	189
47	—	—	—	—	—	—	—	—	—	—	—	—	—	—	8×6.5	G68	155	8×6.5	G68	155	8×10	G10	252	10×10	H10	226
68	—	—	—	—	—	—	—	—	—	—	—	—	—	—	—	—	—	—	—	—	—	—	—	—	—	
100	—	—	—	8×6.5	G68	155	8×6.5	G68	155	8×6.5	G68	155	8×10	G10	252	10×10	H10	458	10×10	H10	226	12.5×13.5	IE	242		
220	8×6.5	G68	155	8×6.5	G68	155	8×10	G10	252	8×10	G10	252	10×10	H10	458	—	—	—	—	—	—	—	—	—	—	
330	8×6.5	G68	155	8×10	G10	252	8×10	G10	252	10×10	H10	458	—	—	—	12.5×13.5	IE	451	—	—	—	—	—	—	—	
470	8×10	G10	252	10×10	H10	458	8×10	G10	252	10×10	H10	458	12.5×13.5	IE	460	—	—	—	—	—	—	—	—	—	—	
820	—	—	—	—	—	—	—	—	—	—	—	—	—	—	—	—	—	—	—	—	—	—	—	—	—	
1000	10×10	H10	458	10×10	H10	458	12.5×13.5	IE	521	—	—	—	—	—	—	—	—	—	—	—	—	—	—	—	—	
1500	—	—	—	12.5×13.5	IE	580	—	—	—	—	—	—	—	—	—	—	—	—	—	—	—	—	—	—	—	
2200	12.5×13.5	IE	651	—	—	—	—	—	—	—	—	—	—	—	—	—	—	—	—	—	—	—	—	—	—	

(Note) Rated ripple current : 85°C, 120Hz

NOTE

Design, Specifications are subject to change without notice.
Ask factory for technical specifications before purchase and/or use.

Chip Type 85°C Capacitors (height:5.5mm,8.0mm)

GREEN CAP

SMD

Anti-cleaning solvent

- Compatible with surface mounting for 5.5mm, 8.0mm high capacitors.
- Supplied with carrier taping.
- Guarantees 2000 hours at 85°C.

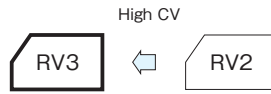

Marking color : Black print

Specifications

Item	Performance						
Category temperature range (°C)	-40 to +85						
Tolerance at rated capacitance (%)	±20 (20°C, 120Hz)						
Leakage current (µA)	Less than 0.01CV or 3 whichever is larger (after 2 minutes) C : Rated capacitance (µF) ; V : Rated voltage (V) (20°C)						
Tangent of loss angle (tanδ)	Rated voltage (V)	6.3	10	16	25	35	50
	tanδ (max.)	0.42	0.32	0.26	0.18	0.14	0.12
Characteristics at high and low temperature	Rated voltage (V)	Z-25°C/Z+20°C	4	3	2	2	2
		Z-40°C/Z+20°C	8	8	5	5	4
	Impedance ratio (max.)	(120Hz)					
Endurance (85°C) (Applied ripple current)	Test time	2000 hours					
	Leakage current	The initial specified value or less					
	Percentage of capacitance change	Within ±30% of initial value					
	Tangent of the loss angle	300% or less of the initial specified value					
Shelf life (85°C)	Test time : 1000 hours ; other items are the same as those for the endurance. Voltage application treatment : According to JIS C5101-1						
Applicable standards	JIS C5101-1 1998, -18 1999 (IEC 60384-1 1992, -18 1993)						

Outline Drawing

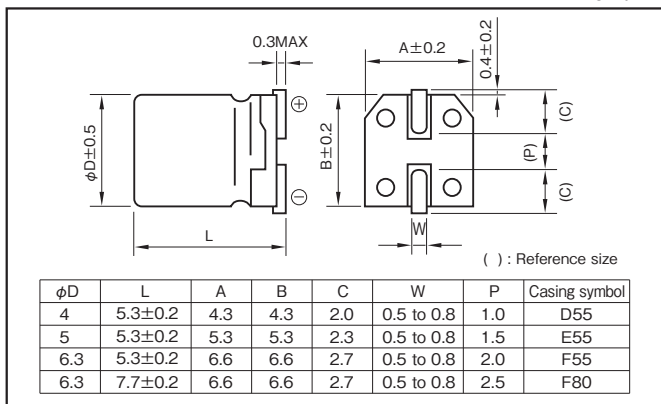

Coefficient of Frequency for Rated Ripple Current

Rated voltage (V)	Frequency (Hz)			
	50	120	1k	10k·100k
6.3 to 16	0.80	1	1.15	1.25
25 to 35	0.80	1	1.25	1.40
50	0.70	1	1.35	1.50

Part numbering system (example : 16V220µF)

RV3	—	16	V	221	M	F80	U	—	□
Series code		Rated voltage symbol		Rated capacitance symbol	Capacitance tolerance symbol	Casing symbol			Taping symbol

- Soldering conditions are described on page 13.
- Land pattern size are described on page 11.
- The taping specifications are described on page 14.

Standard Ratings

Rated capacitance (µF)	Item	6.3			10			16			25			35			50		
		Case	ESR	Rated ripple current	Case	ESR	Rated ripple current	Case	ESR	Rated ripple current	Case	ESR	Rated ripple current	Case	ESR	Rated ripple current	Case	ESR	Rated ripple current
		φD (mm)	(Ω)	(mArms)	φD (mm)	(Ω)	(mArms)	φD (mm)	(Ω)	(mArms)	φD (mm)	(Ω)	(mArms)	φD (mm)	(Ω)	(mArms)	φD (mm)	(Ω)	(mArms)
4.7	—	—	—	—	—	—	—	—	—	—	—	—	—	—	—	4×5.3	42	20	
10	—	—	—	—	—	—	—	—	—	—	—	—	—	—	—	5×5.3	20	34	
22	—	—	—	4×5.3	24	26	4×5.3	20	30	5×5.3	14	43	5×5.3	11	47	6.3×5.3	9.0	59	
33	4×5.3	21	28	4×5.3	16	33	5×5.3	13	44	5×5.3	9.0	54	6.3×5.3	7.0	67	6.3×7.7	6.0	82	
47	4×5.3	15	34	5×5.3	11	45	5×5.3	9.2	50	6.3×5.3	6.4	75	6.3×7.7	4.9	90	6.3×7.7	4.2	98	
68	5×5.3	10	47	5×5.3	7.8	54	6.3×5.3	6.3	74	6.3×5.3	4.4	90	6.3×7.7	3.4	109	—	—	—	
100	5×5.3	7.0	58	—	—	—	6.3×5.3	4.3	103	6.3×7.7	3.0	124	—	—	—	—	—	—	
150	6.3×5.3	4.6	83	6.3×7.7	3.5	98	6.3×7.7	2.9	109	—	—	—	—	—	—	—	—	—	
220	6.3×7.7	3.2	113	6.3×7.7	2.4	130	6.3×7.7	2.0	144	—	—	—	—	—	—	—	—	—	
330	6.3×7.7	2.1	139	—	—	—	—	—	—	—	—	—	—	—	—	—	—	—	

(Note) Rated ripple current : 85°C, 120Hz ; ESR : 20°C, 120Hz

NOTE

Design, Specifications are subject to change without notice.
Ask factory for technical specifications before purchase and/or use.

Chip Type 85°C Capacitors (height:4.5mm)

GREEN CAP

SMD

Anti-cleaning solvent

- Compatible with surface mounting for 4.5mm high capacitors.
- Supplied with carrier taping.
- Guarantees 2000 hours at 85°C.



Low Profile



Marking color : Black print

Specifications

Item	Performance							
Category temperature range (°C)	-40 to +85							
Tolerance at rated capacitance (%)	±20 (20°C, 120Hz)							
Leakage current (µA)	Less than 0.01CV or 3 whichever is larger (after 2 minutes) C : Rated capacitance (µF) ; V : Rated voltage (V) (20°C)							
Tangent of loss angle (tanδ)	Rated voltage (V)	6.3	10	16	25	35	50	
	tanδ (max.)	0.30	0.24	0.19	0.16	0.14	0.12	
Characteristics at high and low temperature	Rated voltage (V)	6.3	10	16	25	35	50	
	Impedance ratio (max.)	Z-25°C/Z+20°C	4	3	2	2	2	2
		Z-40°C/Z+20°C	8	8	4	4	3	3
Endurance (85°C) (Applied ripple current)	Test time	2000 hours						
	Leakage current	The initial specified value or less						
	Percentage of capacitance change	Within ±20% of initial value						
	Tangent of the loss angle	300% or less of the initial specified value						
Shelf life (85°C)	Test time : 1000 hours ; other items are the same as those for the endurance. Voltage application treatment : According to JIS C5101-1							
Applicable standards	JIS C5101-1 1998, -18 1999 (IEC 60384-1 1992, -18 1993)							

Aluminum Electrolytic Capacitors

Outline Drawing

Unit : mm

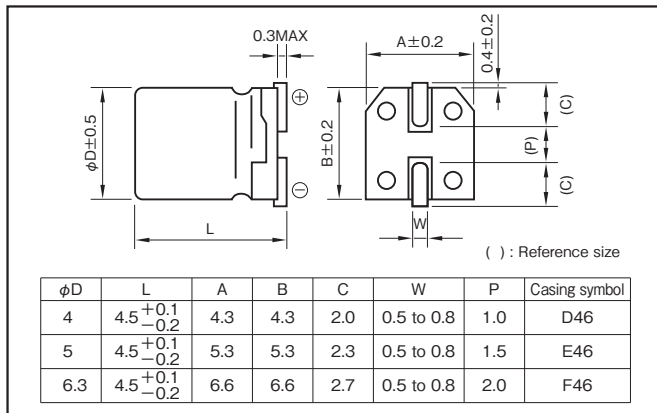

- Soldering conditions are described on page 13.
- Land pattern size are described on page 11.
- The taping specifications are described on page 14.

Coefficient of Frequency for Rated Ripple Current

Rated voltage (V)	Frequency (Hz)			
	50 · 60	120	1k	10k · 100k
6.3 to 16	0.80	1	1.15	1.25
25 to 35	0.70	1	1.25	1.40
50	0.1 to 3.3µF	0.50	1	1.35, 1.50
	4.7 to 10µF	0.70	1	1.35, 1.50

Part numbering system (example : 6.3V47µF)

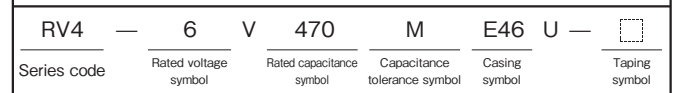

Standard Ratings

Rated capacitance (µF)	6.3			10			16			25			35			50		
	Case	ESR (Ω)	Rated ripple current (mA _{rms})	Case	ESR (Ω)	Rated ripple current (mA _{rms})	Case	ESR (Ω)	Rated ripple current (mA _{rms})	Case	ESR (Ω)	Rated ripple current (mA _{rms})	Case	ESR (Ω)	Rated ripple current (mA _{rms})	Case	ESR (Ω)	Rated ripple current (mA _{rms})
0.22	—	—	—	—	—	—	—	—	—	—	—	—	—	—	—	4	905	4
0.33	—	—	—	—	—	—	—	—	—	—	—	—	—	—	—	4	603	5
0.47	—	—	—	—	—	—	—	—	—	—	—	—	—	—	—	4	423	6
1	—	—	—	—	—	—	—	—	—	—	—	—	—	—	—	4	199	8
2.2	—	—	—	—	—	—	—	—	—	—	—	—	—	—	—	4	90	12
3.3	—	—	—	—	—	—	—	—	—	—	—	—	—	—	—	4	60	15
4.7	—	—	—	—	—	—	—	—	—	4	56	17	4	49	18	5	42	21
10	—	—	—	—	—	—	4	32	22	5	27	28	5	23	30	6.3	20	35
22	4	23	26	5	18	34	5	14	38	6.3	12	49	6.3	11	52	—	—	—
33	5	15	37	5	12	42	6.3	10	55	6.3	8	60	—	—	—	—	—	—
47	5	11	45	6.3	8	59	6.3	7	76	—	—	—	—	—	—	—	—	—
100	6.3	5	76	—	—	—	—	—	—	—	—	—	—	—	—	—	—	—

(Note) Rated ripple current : 85°C, 120Hz ; ESR : 20°C, 120Hz

NOTE

Design, Specifications are subject to change without notice.
Ask factory for technical specifications before purchase and/or use.

Chip Type Large Capacitance Capacitors

GREEN CAP

SMD

Anti-cleaning solvent

- Compatible with surface mounting.
- Supplied with carrier taping.
- Guarantees 2000 hours at 85°C.

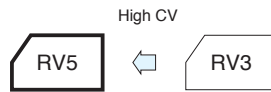

Marking color : Black print (φ3×5.3L—φ8×10L)
White print on a brown sleeve (φ10×10L)

Specifications

Item	Performance								
Category temperature range (°C)	-40 to +85								
Tolerance at rated capacitance (%)	±20 (20°C, 120Hz)								
Leakage current (μA)	Less than 0.01CV or 3 whichever is larger (after 2 minutes) C : Rated capacitance (μF) ; V : Rated voltage (V) (20°C)								
Tangent of loss angle (tanδ)	Rated voltage (V)	6.3	10	16	25	35	50	63	100
	tanδ (max.)	0.35	0.32	0.28	0.18	0.14	0.12	0.12	0.12
Characteristics at high and low temperature	Impedance ratio (max.)	Z-25°C/Z+20°C	4	3	2	2	2	2	2
		Z-40°C/Z+20°C	10	8	6	4	3	3	3
	(120Hz)								
Endurance (85°C) (Applied ripple current)	Test time	2000 hours (φ3 : 1000 hours)							
	Leakage current	The initial specified value or less							
	Percentage of capacitance change	Within ±30% of initial value							
	Tangent of the loss angle	200% or less of the initial specified value							
Shelf life (85°C)	Test time : 1000 hours; other items are the same as those for the endurance. Voltage application treatment : According to JIS C5101-1								
Applicable standards	JIS C5101-1 1998, -18 1999 (IEC 60384-1 1992, -18 1993)								

Outline Drawing

Unit : mm

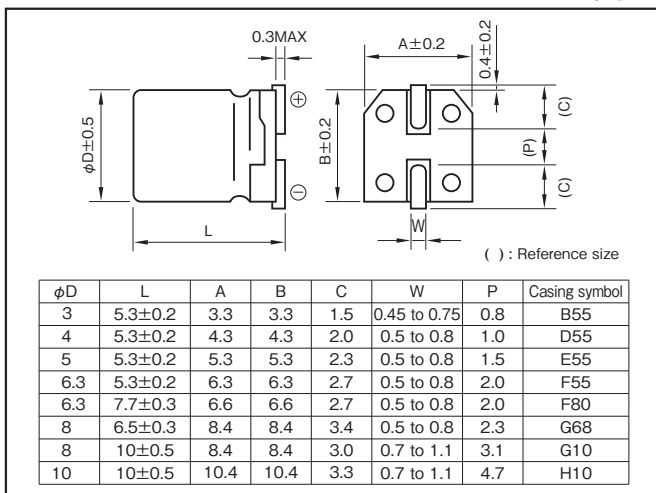

- Soldering conditions are described on page 13.
- Land pattern size are described on page 11.
- The taping specifications are described on page 14.

Coefficient of Frequency for Rated Ripple Current

Rated voltage (V)	Frequency (Hz)			
	50 · 60	120	1k	10k · 100k
6.3 to 16	0.80	1	1.15	1.25
25 to 35	0.80	1	1.25	1.40
50 to 63	0.80	1	1.35	1.50
100	0.70	1	1.35	1.50

Part numbering system (example : 16V470μF)

RV5	—	16	V	471	M	G10	U	—	□
Series code		Rated voltage symbol		Rated capacitance symbol	Capacitance tolerance symbol	Casing symbol			Taping symbol

NOTE

Design, Specifications are subject to change without notice.
Ask factory for technical specifications before purchase and/or use.

Standard Ratings

Rated capacitance (μF)	6.3			10			16			25			35			50			63			100		
	Item		Rated ripple current (mA rms)	Case		Rated ripple current (mA rms)	Case		Rated ripple current (mA rms)	Case		Rated ripple current (mA rms)	Case		Rated ripple current (mA rms)	Case		Rated ripple current (mA rms)	Case		Rated ripple current (mA rms)	Case		Rated ripple current (mA rms)
	φD (mm)	Casing symbol		φD (mm)	Casing symbol		φD (mm)	Casing symbol		φD (mm)	Casing symbol		φD (mm)	Casing symbol		φD (mm)	Casing symbol		φD (mm)	Casing symbol		φD (mm)	Casing symbol	
2.2	—	—	—	—	—	—	—	—	—	—	—	—	—	—	—	—	—	—	—	—	—	—	—	
3.3	—	—	—	—	—	—	—	—	—	—	—	—	—	—	—	—	—	—	—	—	—	—	—	
4.7	—	—	—	—	—	—	—	—	—	—	—	—	—	—	—	—	—	—	—	—	—	—	—	
10	—	—	—	—	—	—	—	—	—	—	—	—	—	—	—	—	—	—	—	—	—	—	—	
22	3×5.3	B55	21	3×5.3	B55	20	—	—	—	4×5.3	D55	24	5×5.3	E55	41	6.3×5.3	F55	47	6.3×7.7	F80	60	—	—	—
33	—	—	—	—	—	—	—	—	—	—	—	—	—	—	—	—	—	—	—	—	—	—	—	
47	4×5.3	D55	34	4×5.3	D55	33	5×5.3	E55	52	—	—	—	6.3×5.3	F55	54	6.3×7.7	F80	85	8×10	G10	139	10×10	H10	189
100	5×5.3	E55	55	5×5.3	E55	54	6.3×5.3	F55	70	6.3×7.7	F80	120	6.3×7.7	F80	120	8×10	G10	252	10×10	H10	226	—	—	—
150	—	—	—	6.3×5.3	F55	79	—	—	—	—	—	—	—	—	—	—	—	—	—	—	—	—	—	
220	6.3×5.3	F55	88	6.3×7.7	F80	173	6.3×7.7	F80	162	—	—	—	8×10	G10	260	—	—	—	—	—	—	—	—	—
330	6.3×7.7	F80	188	—	—	—	—	—	—	8×10	G10	300	10×10	H10	360	—	—	—	—	—	—	—	—	—
470	—	—	—	8×10	G10	310	8×10	G10	307	10×10	H10	400	—	—	—	—	—	—	—	—	—	—	—	
680	—	—	—	—	—	—	10×10	H10	380	—	—	—	—	—	—	—	—	—	—	—	—	—	—	
820	8×10	G10	320	—	—	—	—	—	—	—	—	—	—	—	—	—	—	—	—	—	—	—	—	
1000	—	—	—	10×10	H10	454	—	—	—	—	—	—	—	—	—	—	—	—	—	—	—	—	—	
1500	10×10	H10	489	—	—	—	—	—	—	—	—	—	—	—	—	—	—	—	—	—	—	—	—	

(Note) Rated ripple current : 85°C, 120Hz

Chip Type Aluminum Electrolytic Capacitors

Chip Type Bipolar Capacitors (height:5.5mm)

GREEN CAP

SMD

Anti-cleaning solvent

- Compatible with surface mounting for 5.5mm high capacitors.
- Supplied with carrier taping.
- Guarantees 2000 hours at 85°C.

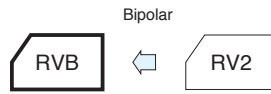

Marking color : Black print

Specifications

Item	Performance							
Category temperature range (°C)	-40 to +85							
Tolerance at rated capacitance (%)	±20 (20°C, 120Hz)							
Leakage current (µA)	Less than 0.01CV or 3 whichever is larger (after 2 minutes) C : Rated capacitance (µF) ; V : Rated voltage (V) (20°C)							
Tangent of loss angle (tanδ)	Rated voltage (V)		6.3	10	16	25	35	50
	tanδ (max.)	φ4	0.35	0.30	0.25	0.25	0.25	0.25
		φ5, 6.3	0.30	0.25	0.20	0.15	0.15	0.15
Characteristics at high and low temperature	Rated voltage (V)		6.3	10	16	25	35	50
	Impedance ratio (max.)	Z-25°C/Z+20°C	3	3	2	2	2	2
		Z-40°C/Z+20°C	8	5	4	3	3	3
Endurance (85°C) (Applied ripple current)	Test time		2000 hours (with the polarity inverted every 250 hours)					
	Leakage current		The initial specified value or less					
	Percentage of capacitance change		Within ±20% of initial value					
	Tangent of the loss angle		200% or less of the initial specified value					
Shelf life (85°C)	Test time : 1000hours; other items are the same as those for the endurance. Voltage application treatment : According to JIS C5101-1							
Applicable standards	JIS C5101-1 1998, -18 1999 (IEC 60384-1 1992, -18 1993)							

Outline Drawing

Unit : mm

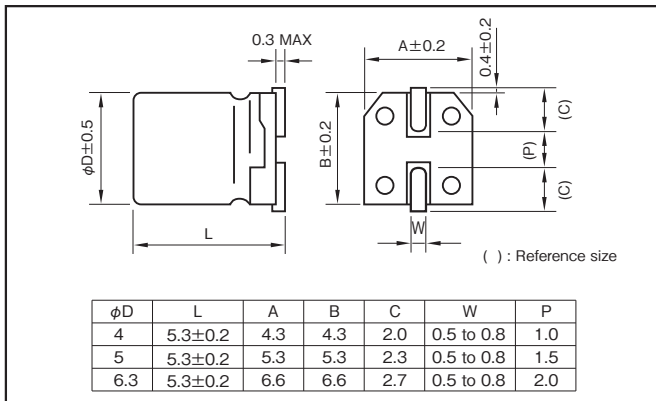

- Soldering conditions are described on page 13.
- Land pattern size are described on page 11.
- The taping specifications are described on page 14.

Coefficient of Frequency for Rated Ripple Current

Rated voltage (V)	Frequency (Hz)			
	50	120	1k	10k-100k
6.3 to 16	0.80	1	1.15	1.25
25 to 35	0.80	1	1.25	1.40
50	0.80	1	1.35	1.50

Part numbering system (example : 6.3V47µF)

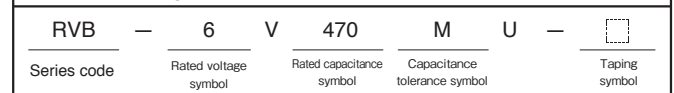

Standard Ratings

Rated capacitance (µF)	6.3			10			16			25			35			50		
	Case φD(mm)	ESR (Ω)	Rated ripple current (mA)	Case φD(mm)	ESR (Ω)	Rated ripple current (mA)	Case φD(mm)	ESR (Ω)	Rated ripple current (mA)	Case φD(mm)	ESR (Ω)	Rated ripple current (mA)	Case φD(mm)	ESR (Ω)	Rated ripple current (mA)	Case φD(mm)	ESR (Ω)	Rated ripple current (mA)
0.22	—	—	—	—	—	—	—	—	—	—	—	—	—	—	—	4	1510	3.3
0.33	—	—	—	—	—	—	—	—	—	—	—	—	—	—	—	4	1010	4.1
0.47	—	—	—	—	—	—	—	—	—	—	—	—	—	—	—	4	706	4.9
1	—	—	—	—	—	—	—	—	—	—	—	—	—	—	—	4	332	7.2
2.2	—	—	—	—	—	—	—	—	—	—	—	—	4	151	10	5	113	14
3.3	—	—	—	—	—	—	—	—	4	101	13	5	75	17	5	75	17	—
4.7	—	—	—	—	—	—	4	88	14	5	53	20	5	53	21	6.3	53	24
10	—	—	—	4	50	18	5	33	26	6.3	25	35	6.3	25	35	—	—	—
22	5	23	27	6.3	19	40	6.3	15	45	—	—	—	—	—	—	—	—	—
33	6.3	15	45	6.3	13	50	6.3	10	55	—	—	—	—	—	—	—	—	—
47	6.3	11	54	—	—	—	—	—	—	—	—	—	—	—	—	—	—	—

(Note) Rated ripple current : 85°C, 120Hz ; ESR : 20°C, 120Hz

NOTE

Design, Specifications are subject to change without notice. Ask factory for technical specifications before purchase and/or use.

Chip type 105°C Capacitors(height:4.5mm)

GREEN CAP

SMD

Anti-cleaning solvent

- Compatible with surface mounting.
- Supplied with carrier taping.
- Guarantees 1000 hours 105°C.

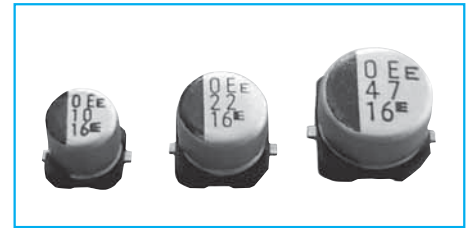
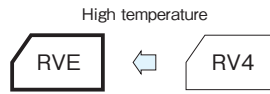

Marking color : Black print

Specifications

Item	Performance						
Category temperature range (°C)	-40 to +105						
Tolerance at rated capacitance (%)	±20 (20°C,120Hz)						
Leakage current (μA)	Less than 0.01CV or 3 whichever is larger (after 2 minutes) C : Rated capacitance (μF), V : Rated voltage (V) (20°C)						
Tangent of loss angle (tanδ)	Rated voltage (V)	6.3	10	16	25	35	50
	tanδ (max.)	0.38	0.32	0.20	0.16	0.14	0.14
Characteristics at high and low temperature	Rated voltage (V)	6.3	10	16	25	35	50
	Impedance ratio (max.)	Z-25°C/Z+20°C	4	3	2	2	2
		Z-40°C/Z+20°C	10	8	6	4	3
Endurance (105°C)	Test time	1000 hours					
	Leakage current	The initial specified value or less					
	Percentage of capacitance change	Within ±20% of initial value (16VV or less:±25%)					
	Tangent of loss angle	300% or less of the initial specified value					
Shelf life (105°C)	Test time : 500 hours ; other items are the same as those for the endurance. Voltage application treatment						
Applicable standards	JIS C5101-1 1998, -18 1999 (IEC 60384-1 1992, -18 1993)						

Aluminum Electrolytic Capacitors

Outline Drawing

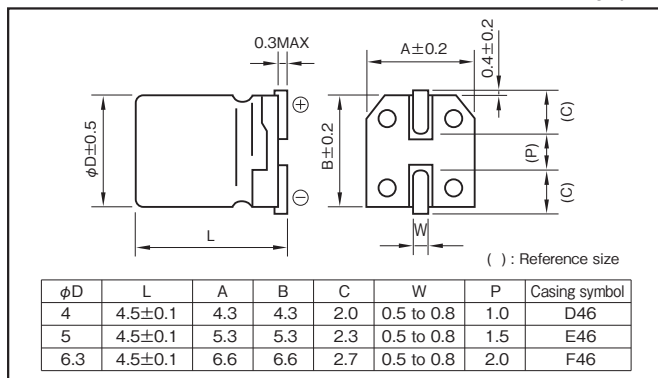

Coefficient of Frequency for Rated Ripple Current

Rated voltage (V)	Frequency (Hz)			
	50 · 60	120	1k	10k · 100k
6.3 to 16	0.80	1.00	1.15	1.25
25 to 35	0.80	1.00	1.25	1.40
50	0.1 to 3.3μF	0.50	1.00	1.35
	4.7μF to	0.70	1.00	1.50

Part numbering system (example : 16V100μF)

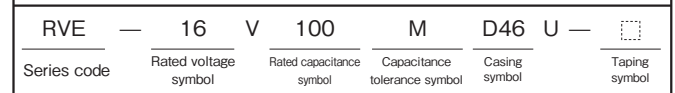

- Soldering conditions are described on page 13.
- Land pattern size are described on page 11.
- The taping specifications are described on page 14.

Standard Ratings

Rated capacitance (μF)	6.3		10		16		25		35		50	
	Case	Rated ripple current (mA _{RMS})	Case	Rated ripple current (mA _{RMS})	Case	Rated ripple current (mA _{RMS})	Case	Rated ripple current (mA _{RMS})	Case	Rated ripple current (mA _{RMS})	Case	Rated ripple current (mA _{RMS})
0.22	—	—	—	—	—	—	—	—	—	—	4	2.2
0.33	—	—	—	—	—	—	—	—	—	—	4	2.8
0.47	—	—	—	—	—	—	—	—	—	—	4	3.3
1	—	—	—	—	—	—	—	—	—	—	4	5.4
2.2	—	—	—	—	—	—	—	—	—	—	4	9.6
3.3	—	—	—	—	—	—	—	—	—	—	4	12
4.7	—	—	—	—	—	—	4	11	4	13	5	16
10	—	—	—	—	4	16	5	20	5	22	6.3	26
22	4	19	5	24	5	26	6.3	33	6.3	36	—	—
33	5	26	5	30	6.3	35	6.3	42	—	—	—	—
47	5	32	6.3	40	6.3	44	—	—	—	—	—	—
100	6.3	52	—	—	—	—	—	—	—	—	—	—

(Note) Rated ripple current : 105°C, 120Hz

NOTE

Design, Specifications are subject to change without notice.
Ask factory for technical specifications before purchase and/or use.

Chip Type 105°C Standard Capacitors

GREEN CAP

SMD

105°C
1000hours

Anti-cleaning solvent

- Compatible with surface mounting.
- Supplied with carrier taping.
- Guarantees 1000 hours at 105°C.



High temperature



Marking color : Black print

Specifications

Item	Performance							
Category temperature range (°C)	-55 to +105							
Tolerance at rated capacitance (%)	±20 (20°C, 120Hz)							
Leakage current (µA)	Less than 0.01CV or 3 whichever is larger (after 2 minutes) C : Rated capacitance (µF) ; V : Rated voltage (V) (20°C)							
Tangent of loss angle (tanδ)	Rated voltage (V)	6.3	10	16	25	35	50	
	tanδ (max.)	0.30	0.26	0.22	0.16	0.13	0.12	
(20°C, 120Hz)								
Characteristics at high and low temperature	Impedance ratio (max.)	Rated voltage (V)	6.3	10	16	25	35	50
		Z-25°C/Z+20°C	4	3	2	2	2	2
(120Hz)								
Endurance (105°C) (Applied ripple current)	Test time	1000 hours						
	Leakage current	The initial specified value or less						
	Percentage of capacitance change	Within ±20% of initial value						
	Tangent of the loss angle	200% or less of the initial specified value						
Shelf life (105°C)	Test time : 1000 hours; other items are the same as those for the endurance. Voltage application treatment : According to JIS C5101-1							
Applicable standards	JIS C5101-1 1998, -18 1999 (IEC 60384-1 1992, -18 1993)							

Outline Drawing

Unit : mm

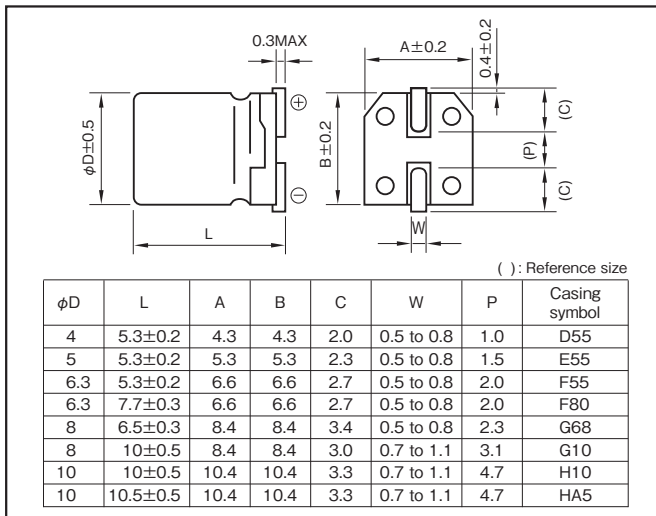

Coefficient of Frequency for Rated Ripple Current

Frequency (Hz)	50 · 60	120	1k	10k · 100k
Rated voltage (V)				
6.3 to 16	0.80	1	1.15	1.25
25 to 35	0.80	1	1.25	1.40
50	0.80	1	1.35	1.50

Part numbering system (example : 16V47µF)

RVS	—	16	V	470	M	F55	U	□
Series code		Rated voltage symbol		Rated capacitance symbol	Capacitance tolerance symbol	Casing symbol		Taping symbol

- Soldering conditions are described on page 13.
- Land pattern size are described on page 11.
- The taping specifications are described on page 14.

NOTE

Design, Specifications are subject to change without notice. Ask factory for technical specifications before purchase and/or use.

Standard Ratings

Rated capacitance (μF)	Item	6.3			10			16			25			35			50		
		Case	ESR	Rated ripple current	Case	ESR	Rated ripple current	Case	ESR	Rated ripple current	Case	ESR	Rated ripple current	Case	ESR	Rated ripple current	Case	ESR	Rated ripple current
		φD×L(mm)	(Ω)	(mAmps)	φD×L(mm)	(Ω)	(mAmps)	φD×L(mm)	(Ω)	(mAmps)	φD×L(mm)	(Ω)	(mAmps)	φD×L(mm)	(Ω)	(mAmps)	φD×L(mm)	(Ω)	(mAmps)
0.22	—	—	—	—	—	—	—	—	—	—	—	—	—	—	—	4×5.3	905	3	
0.33	—	—	—	—	—	—	—	—	—	—	—	—	—	—	—	4×5.3	603	4	
0.47	—	—	—	—	—	—	—	—	—	—	—	—	—	—	—	4×5.3	424	5	
1	—	—	—	—	—	—	—	—	—	—	—	—	—	—	—	4×5.3	199	7	
2.2	—	—	—	—	—	—	—	—	—	—	—	—	—	—	—	4×5.3	91	10	
3.3	—	—	—	—	—	—	—	—	—	—	—	—	—	—	—	4×5.3	60	12	
4.7	—	—	—	—	—	—	—	—	—	4×5.3	57	12	4×5.3	46	14	5×5.3	42	17	
10	—	—	—	4×5.3	43	15	4×5.3	36	16	5×5.3	27	21	5×5.3	22	23	6.3×5.3	20	26	
22	4×5.3	23	21	5×5.3	20	25	5×5.3	17	28	6.3×5.3	12	36	6.3×5.3	10	50	8×6.5	9.0	51	
33	5×5.3	15	30	5×5.3	13	31	6.3×5.3	11	40	6.3×5.3	8.0	44	8×6.5	6.5	59	6.3×7.7	6.0	60	
47	5×5.3	11	36	6.3×5.3	9.2	43	6.3×5.3	7.8	47	8×6.5	5.6	66	—	—	—	6.3×7.7	4.2	63	
100	6.3×5.3	5.0	61	6.3×5.3	4.3	60	6.3×5.3	3.6	60	6.3×7.7	2.7	91	6.3×7.7	2.2	84	8×10	2.0	140	
150	—	—	—	—	—	—	6.3×7.7	2.4	105	8×10	1.8	140	8×10	1.4	155	10×10	1.3	180	
220	8×6.5	2.3	102	6.3×7.7	2.0	105	6.3×7.7	1.7	105	8×10	1.2	155	8×10	0.98	190	10×10.5	0.91	220	
330	6.3×7.7	1.5	105	8×10	1.3	195	8×10	1.1	195	8×10	0.80	190	10×10.5	0.65	300	—	—	—	
470	8×10	1.1	210	8×10	0.92	210	8×10	0.78	230	10×10	0.57	300	—	—	—	—	—	—	
680	8×10	0.73	210	10×10	0.63	310	10×10	0.54	310	—	—	—	—	—	—	—	—	—	
1000	8×10	0.50	210	10×10	0.43	310	—	—	—	—	—	—	—	—	—	—	—	—	
1500	10×10	0.33	310	—	—	—	—	—	—	—	—	—	—	—	—	—	—	—	

(Note) Rated ripple current : 105°C , 120Hz ; ESR : 20°C , 120Hz

Chip Type 105°C Capacitors (height:6.0mm)

GREEN CAP

SMD

105°C
2000hours

Anti-cleaning solvent

- Compatible with surface mounting for 6.0mm high capacitors.
- Supplied with carrier taping.
- Guarantees 2000 hours at 105°C.

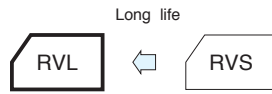

Marking color : Black print

Specifications

Item	Performance						
Category temperature range (°C)	-55 to +105						
Tolerance at rated capacitance (%)	±20 (20°C,120Hz)						
Leakage current (μA)	Less than 0.01CV or 3 whichever is larger (after 2 minutes) C : Rated capacitance (μF) ; V : Rated voltage (V) (20°C)						
Tangent of loss angle (tanδ)	Rated voltage (V)	6.3	10	16	25	35	50
	tanδ (max.)	0.32	0.28	0.24	0.18	0.15	0.14
Characteristics at high and low temperature	Rated voltage (V)	Z-25°C/Z+20°C	4	3	2	2	2
		Z-40°C/Z+20°C	8	5	4	3	3
	Impedance ratio (max.)	(120Hz)					
Endurance (105°C) (Applied ripple current)	Test time	2000 hours					
	Leakage current	The initial specified value or less					
	Percentage of capacitance change	Within ±30% of initial value					
	Tangent of the loss angle	300% or less of the initial specified value					
Shelf life (105°C)	Test time : 1000hours ; other items are the same as those for the endurance. Voltage application treatment : According to JIS C5101-1						
Applicable standards	JIS C5101-1 1998, -18 1999 (IEC 60384-1 1992, -18 1993)						

Outline Drawing

Unit : mm

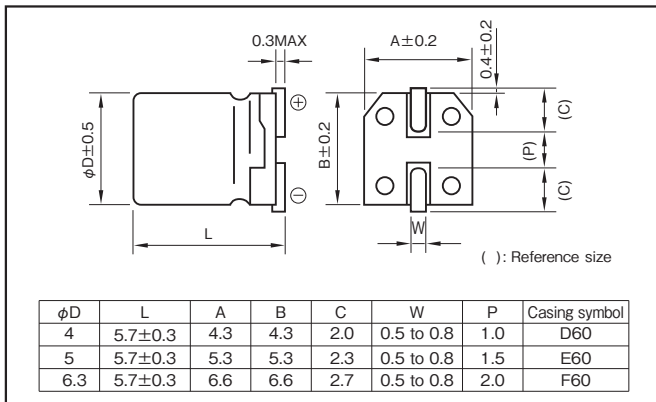

- Soldering conditions are described on page 13.
- Land pattern size are described on page 11.
- The taping specifications are described on page 14.

Coefficient of Frequency for Rated Ripple Current

Rated voltage (V)	Frequency (Hz)			
	50 · 60	120	1k	10k · 100k
6.3 to 16	0.8	1	1.15	1.25
25 · 35	0.8	1	1.25	1.40
50	0.1 to 3.3μF	0.5	1	1.35
	4.7 to 10μF	0.7	1	1.35

Part numbering system (example : 16V470M F60 U)

RVL	—	16	V	470	M	F60	U	□
Series code		Rated voltage symbol		Rated capacitance symbol	Capacitance tolerance symbol	Casing symbol		Taping symbol

Standard Ratings

Rated voltage (V)	Item	6.3			10			16			25			35			50		
		Case	ESR (Ω)	Rated ripple current (mAmps)	Case	ESR (Ω)	Rated ripple current (mAmps)	Case	ESR (Ω)	Rated ripple current (mAmps)	Case	ESR (Ω)	Rated ripple current (mAmps)	Case	ESR (Ω)	Rated ripple current (mAmps)	Case	ESR (Ω)	Rated ripple current (mAmps)
0.22	—	—	—	—	—	—	—	—	—	—	—	—	—	—	—	—	—	—	—
0.33	—	—	—	—	—	—	—	—	—	—	—	—	—	—	—	—	—	—	—
0.47	—	—	—	—	—	—	—	—	—	—	—	—	—	—	—	—	—	—	—
1	—	—	—	—	—	—	—	—	—	—	—	—	—	—	—	—	—	—	—
2.2	—	—	—	—	—	—	—	—	—	—	—	—	—	—	—	—	—	—	—
3.3	—	—	—	—	—	—	—	—	—	—	—	—	—	—	—	—	—	—	—
4.7	—	—	—	—	—	—	—	—	—	—	—	—	—	—	—	—	—	—	—
10	—	—	—	—	—	—	—	4	40	27	5	30	36	5	25	39	6.3	23	47
22	—	—	—	—	—	—	—	5	18	46	6.3	14	62	6.3	11	65	—	—	—
33	—	—	—	—	—	—	—	6.3	12	66	6.3	9.0	76	—	—	—	—	—	—
47	—	—	—	—	—	—	—	6.3	9.9	74	6.3	8.5	78	—	—	—	—	—	—
100	6.3	5.3	99	—	—	—	—	—	—	—	—	—	—	—	—	—	—	—	—

(Note) Rated ripple current : 105°C, 120Hz ; ESR : 20°C, 120Hz

Chip Type, 105°C Use, Large Capacitance Capacitors

GREEN CAP

SMD

105°C
2000hours

Anti-cleaning solvent

- Compatible with surface mounting.
- Supplied with carrier taping.
- Guarantees 2000 hours at 105°C.
($\phi 12.5 \times 13.5L$: 5000 hours at 105°C)



High temperature



Marking color : Black print ($\phi 8 \times 6.5L$)
White print on a brown sleeve ($\phi 8 \times 10L - \phi 12.5 \times 13.5L$)

Specifications

Item	Performance									
Category temperature range (°C)	-55 to +105									
Tolerance at rated capacitance (%)	± 20 (20°C, 120Hz)									
Leakage current (μA)	Less than 0.01CV or 3 whichever is larger (after 2 minutes) C : Rated capacitance (μF) ; V : Rated voltage (V) (20°C)									
Tangent of loss angle (tan δ)	Rated voltage (V)	6.3	10	16	25	35	50	63	100	
	tan δ (max.)	0.30	0.24	0.22	0.16	0.13	0.12	0.11	0.10	(20°C, 120Hz)
Characteristics at high and low temperature	Rated voltage (V)	6.3	10	16	25	35	50	63	100	
	Impedance ratio (max.)	Z-25°C/Z+20°C	4	3	2	2	2	2	2	2
Endurance (105°C) (Applied ripple current)	Test time	2000 hours ($\phi 12.5 \times 13.5L$: 5000 hours)								
	Leakage current	The initial specified value or less								
	Percentage of capacitance change	Within $\pm 20\%$ of initial value								
	Tangent of the loss angle	200% or less of the initial specified value								
Shelf life (105°C)	Test time : 1000 hours ; other items are the same as those for the endurance. Voltage application treatment : According to JIS C5101-1									
Applicable standards	JIS C 5101-1 1998, -18 1999 (IEC 60384-1 1992, -18 1993)									

Aluminum Electrolytic Capacitors
Chip Type

Outline Drawing

Unit : mm

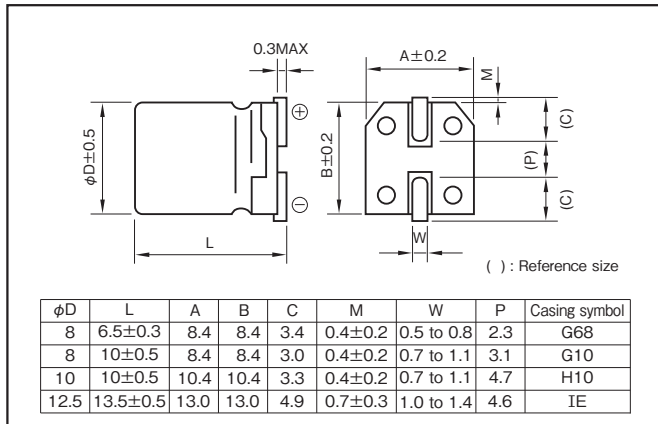

- Soldering conditions are described on page 13.
- Land pattern size are described on page 11.
- The taping specifications are described on page 14.

Coefficient of Frequency for Rated Ripple Current

Rated voltage (V)	Frequency (Hz)			
	50 · 60	120	1k	10k · 100k
6.3 to 16	0.80	1	1.15	1.25
25 to 35	0.80	1	1.25	1.40
50 to 63	0.80	1	1.35	1.50
100	0.70	1	1.35	1.50

Rated capacitance (μF)	Frequency (Hz)			
	120	1k	10k	100k
47	0.50	0.76	0.87	1
100 to 220	0.70	0.85	0.90	1
330 to 1000	0.80	0.93	0.98	1

Part numbering system

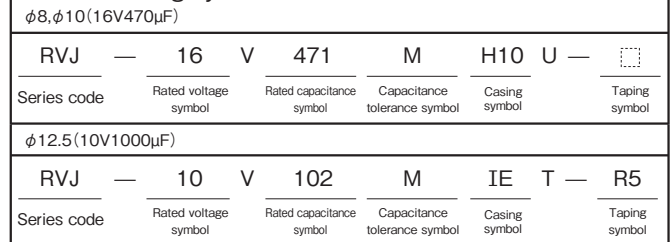

Standard Ratings

Rated capacitance (μF)	6.3			10			16			25			35			50			63			100					
	Case ϕD (mm)	Casing symbol	Rated ripple current (mA rms)	Case ϕD (mm)	Casing symbol	Rated ripple current (mA rms)	Case ϕD (mm)	Casing symbol	Rated ripple current (mA rms)	Case ϕD (mm)	Casing symbol	Rated ripple current (mA rms)	Case ϕD (mm)	Casing symbol	Rated ripple current (mA rms)	Case ϕD (mm)	Casing symbol	Rated ripple current (mA rms)	Case ϕD (mm)	Casing symbol	Rated ripple current (mA rms)						
10	—	—	—	—	—	—	—	—	—	—	—	—	—	—	—	—	—	—	—	—	—	—					
22	—	—	—	—	—	—	—	—	—	—	—	—	—	—	—	8x6.5	G68	110	8x10	G10	99	10x10	H10	133			
33	—	—	—	—	—	—	—	—	—	—	—	—	—	—	8x6.5	G68	110	8x10	G10	178	10x10	H10	160	10x10	H10	133	
47	—	—	—	—	—	—	—	—	—	—	—	—	—	—	8x6.5	G68	110	8x10	G10	178	10x10	H10	160	12.5x13.5	IE	475*	
100	—	—	—	8x6.5	G68	110	8x6.5	G68	110	8x10	G10	178	8x10	G10	178	8x10	G10	178	8x10	G10	178	10x10	H10	160	12.5x13.5	IE	577*
220	8x10	G10	178	8x10	G10	178	10x10	H10	324	10x10	H10	324	10x10	H10	324	12.5x13.5	IE	655*	—	—	—	—	—	—	—	—	
330	8x10	G10	178	10x10	H10	324	10x10	H10	324	10x10	H10	324	12.5x13.5	IE	747*	—	—	—	—	—	—	—	—	—	—	—	—
470	10x10	H10	324	10x10	H10	324	10x10	H10	324	12.5x13.5	IE	747*	12.5x13.5	IE	747*	—	—	—	—	—	—	—	—	—	—	—	
1000	10x10	H10	324	10x10	H10	324	12.5x13.5	IE	747*	—	—	—	—	—	—	—	—	—	—	—	—	—	—	—	—	—	

NOTE
Design, Specifications are subject to change without notice.
Ask factory for technical specifications before purchase and/or use.

(Note) Rated ripple current : 105°C, 120Hz
(Note*) Rated ripple current : 105°C, 100kHz

Chip type, 105°C Use, Long Life, High CV Capacitors

GREEN CAP

SMD

105°C
2000hours

Anti-cleaning solvent

- Compatible with surface mounting.
- Supplied with carrier taping.
- Guarantees 2000 hours 105°C.

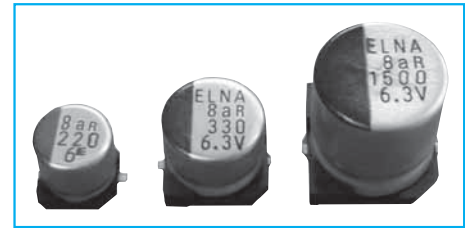
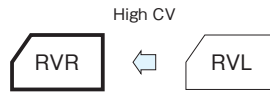

Marking color : Black print

Specifications

Item	Performance								
Category temperature range (°C)	-40 to +105								
Tolerance at rated capacitance (%)	±20 (20°C, 120Hz)								
Leakage current (µA)	Less than 0.01CV or 3 whichever is larger (after 2 minutes) C : Rated capacitance (µF), V : Rated voltage (V) (20°C)								
Tangent of loss angle (tanδ)	Rated voltage (V)	4	6.3	10	16	25	35	50	
	tanδ (max.)	0.50	0.30	0.22	0.16	0.14	0.12	0.12	
Characteristics at high and low temperature	Impedance ratio (max.)	Rated voltage (V)	4	6.3	10	16	25	35	50
		Z-25°C/Z+20°C	7	4	3	2	2	2	2
	Z-40°C/Z+20°C	15	8	6	4	4	3	3	
Endurance (105°C)	Test time	2000 hours							
	Leakage current	The initial specified value or less							
	Percentage of capacitance change	Within ±20% of initial value(φ5 or Smaller(16V or less):±30%)							
	Tangent of loss angle	200% or less of the initial specified value							
Shelf life (105°C)	Test time : 1000 hours ; other items are the same as those for the endurance. Voltage application treatment								
Applicable standards	JIS C5101-1 1998, -18 1999(IEC 60384-1 1992, -18 1993)								

Outline Drawing

Unit : mm

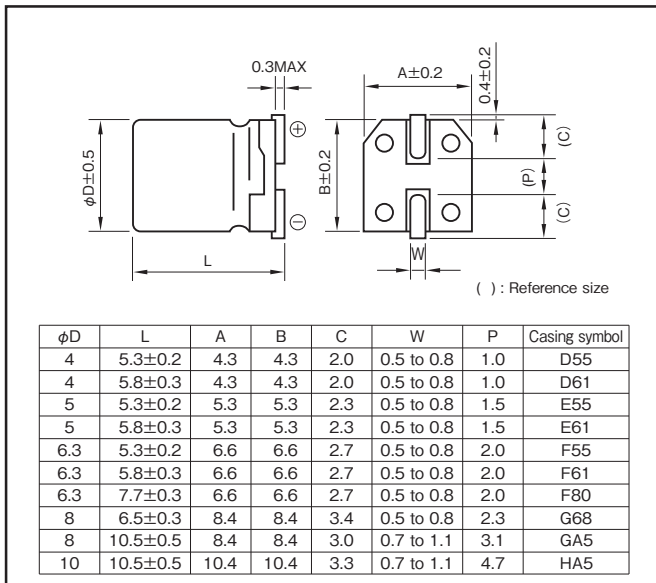

Coefficient of Frequency for Rated Ripple Current

Frequency (Hz)	50 - 60	120	1k	10k · 100k
Rated voltage (V) 6.3 to 16	0.80	1.00	1.15	1.25
25 to 35	0.80	1.00	1.25	1.40
50	0.50	1.00	1.35	1.50

Part numbering system (example : 16V100µF)

RVR	—	16	V	101	M	F61	U	□
Series code		Rated voltage symbol		Rated capacitance symbol	Capacitance tolerance symbol	Casing symbol		Taping symbol

- Soldering conditions are described on page 13.
- Land pattern size are described on page 11.
- The taping specifications are described on page 14.

NOTE

Design, Specifications are subject to change without notice. Ask factory for technical specifications before purchase and/or use.

Standard Ratings

Rated voltage(V) Rated capacitance(μF)	Item	4			6.3			10			16			25			
		Case φD×L (mm)	Casing symbol	Rated ripple current (mArms)	Case φD×L (mm)	Casing symbol	Rated ripple current (mArms)	Case φD×L (mm)	Casing symbol	Rated ripple current (mArms)	Case φD×L (mm)	Casing symbol	Rated ripple current (mArms)	Case φD×L (mm)	Casing symbol	Rated ripple current (mArms)	
4.7	-	-	-	-	-	-	-	-	-	-	-	-	4×5.3	D55	22		
6.8	-	-	-	-	-	-	-	-	-	-	-	-	4×5.3	D55	25		
10	-	-	-	-	-	-	-	-	-	-	-	4×5.3	D55	28	4×5.8	D61	36
												4×5.8	D61	27			
22	-	-	-	4×5.3	D55	26	4×5.8	D61	33	4×5.8	D61	39	5×5.8	E61	48		
				4×5.8	D61	28				5×5.3	E55	39					
33	-	-	-	5×5.8	E61	40	4×5.8	D61	41	5×5.8	E61	55	5×5.8	E61	59		
							5×5.3	E55	46	5×5.8	E61	47	6.3×5.8	F61	66	6.3×5.3	F55
47	4×5.8	D61	42	5×5.8	E61	48	6.3×5.8	F61	74	6.3×5.8	F61	78	6.3×5.8	F61	82		
				6.3×5.3	F55	71				5×5.8	E61	66				6.3×5.8	F61
100	5×5.8	E61	70	6.3×5.3	F55	71	6.3×5.8	F61	95	6.3×5.8	F61	112	6.3×7.7	F80	132		
				6.3×5.8	F61	99							8×6.5	G68	146		
150	-	-	-	-	-	-	6.3×5.8	F61	117	8×6.5	G68	151	-	-	-		
220	6.3×5.8	F61	121	6.3×5.8	F61	121	6.3×7.7	F80	156	6.3×7.7	F80	183	8×10	G10	320		
330	6.3×7.7	F80	163	6.3×7.7	F80	163	8×6.5	G68	173	8×6.5	G68	157	8×10.5	GA5	340		
	8×6.5	G68	181	8×6.5	G68	181	8×10	G10	296	8×10.5	GA5	291	8×10.5	GA5	340		
470	-	-	-	8×10	G10	320	8×10	G10	326	8×10	G10	348	10×10.5	HA5	490		
				8×10.5	GA5	320	8×10.5	GA5	326	8×10.5	GA5	348					
680	-	-	-	8×10.5	GA5	340	10×10	H10	440	10×10	H10	484	-	-	-		
820	-	-	-	-	-	-	-	-	-	-	-	-	-	-	-		
				10×10	H10	495	10×10.5	HA5	500	-	-	-	-	-	-		
1000	-	-	-	10×10.5	HA5	495	10×10.5	HA5	500	-	-	-	-	-	-		
1200	-	-	-	-	-	-	10×10.5	HA5	500	-	-	-	-	-	-		
1500	-	-	-	10×10.5	HA5	550	-	-	-	-	-	-	-	-	-		

Chip Type
Aluminum Electrolytic Capacitors

Rated voltage(V) Rated capacitance(μF)	Item	35			50		
		Case φD×L (mm)	Casing symbol	Rated ripple current (mArms)	Case φD×L (mm)	Casing symbol	Rated ripple current (mArms)
0.22	-	-	-	4×5.3	D55	2	
0.33	-	-	-	4×5.3	D55	3	
0.47	-	-	-	4×5.3	D55	5	
1	-	-	-	4×5.3	D55	10	
				4×5.8	D61	12	
2.2	-	-	-	4×5.3	D55	16	
				4×5.8	D61	19	
3.3	-	-	-	4×5.3	D55	16	
				4×5.8	D61	22	
4.7	4×5.8	D61	23	4×5.8	D61	26	
				5×5.3	E55	23	
6.8	-	-	-	5×5.8	E61	29	
				5×5.3	E55	23	
10	4×5.8	D61	30	5×5.8	E61	35	
	5×5.3	E55	28	6.3×5.3	F55	35	
	5×5.8	E61	39	6.3×5.8	F61	47	
22	5×5.8	E61	52	6.3×5.8	F61	61	
	6.3×5.3	F55	55	-	-	-	
33	6.3×5.8	F61	74	6.3×7.7	F80	82	
				8×6.5	G68	91	
47	6.3×5.8	F61	89	6.3×7.7	F80	97	
				8×6.5	G68	108	
68	6.3×7.7	F80	117	-	-	-	
	8×6.5	G68	130	-	-	-	
100	6.3×7.7	F80	142	8×10.5	GA5	230	
	8×6.5	G68	158				
	8×10	G10	283	10×10.5	HA5	262	
	8×10.5	GA5	283				
150	8×10	G10	293	10×10.5	HA5	300	
	8×10.5	GA5	293	-	-	-	
220	8×10.5	GA5	302	10×10.5	HA5	375	
	10×10	H10	450	-	-	-	
330	10×10.5	HA5	450	-	-	-	

(Note) Rated ripple current : 105° C, 120Hz

NOTE

Design, Specifications are subject to change without notice.
Ask factory for technical specifications before purchase and/or use.

Chip Type, 105°C Use, Long Life Capacitors

GREEN CAP

SMD

105°C
3000hours

Anti-cleaning solvent

- Compatible with surface mounting.
- Supplied with carrier taping.
- Guarantees 3000 hours at 105°C. (10L:5000 hours).

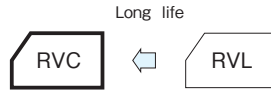

Marking color : Black print

Specifications

Item	Performance						
Category temperature range (°C)	-40 to +105						
Tolerance at rated capacitance (%)	±20 (20°C,120Hz)						
Leakage current (µA)	Less than 0.01CV or 3 whichever is larger (after 2 minutes) C : Rated capacitance (µF), V : Rated voltage (V) (20°C)						
Tangent of loss angle (tanδ)	Rated voltage (V)	6.3	10	16	25	35	50
	tanδ (max.)	0.28	0.24	0.20	0.16	0.13	0.12
Characteristics at high and low temperature	Impedance ratio (max.)	Z-25°C/Z+20°C	4	3	2	2	2
		Z-40°C/Z+20°C	10	7	5	3	3
Endurance (105°C)	Test time	3000 hours (10L : 5000 hours)					
	Leakage current	The initial specified value or less					
	Percentage of capacitance change	Within ±30% of initial value					
	Tangent of the loss angle	300% or less of initial specified value					
Shelf life (105°C)	Test time : 1000 hours ; other items are the same as those for the endurance. Voltage application treatment : According to JIS C5101-1						
Applicable standards	JIS C5101-1 1998, -18 1999 (IEC 60384-1 1992, -18 1993)						

Outline Drawing

Unit : mm

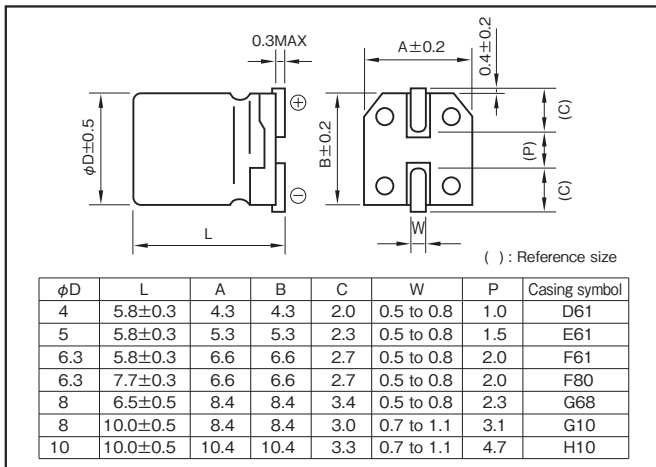

- Soldering conditions are described on page 13.
- Land pattern size are described on page 11.
- The taping specifications are described on page 14.

Coefficient of Frequency for Rated Ripple Current

Frequency (Hz)	50	120	1k	10k·100k
Rated voltage (V)				
6.3 to 16	0.8	1	1.15	1.25
25 to 35	0.8	1	1.25	1.40
50	0.1 to 3.3µF	0.5	1	1.35
	4.7µF to	0.7	1	1.35

Part numbering system (example : 16V47µF)

RVC	—	16	V	470	M	F61	U	□
Series code		Rated voltage symbol		Rated capacitance symbol	Capacitance tolerance symbol	Casing symbol		Taping symbol

Standard Ratings

Rated voltage (V) Item Rated capacitance (μF)	6.3			10			16			25			35			50		
	Case φD(mm)	Casing symbol	Rated ripple current mA Arms	Case φD(mm)	Casing symbol	Rated ripple current mA Arms	Case φD(mm)	Casing symbol	Rated ripple current mA Arms	Case φD(mm)	Casing symbol	Rated ripple current mA Arms	Case φD(mm)	Casing symbol	Rated ripple current mA Arms	Case φD(mm)	Casing symbol	Rated ripple current mA Arms
0.22	—	—	—	—	—	—	—	—	—	—	—	—	—	—	—	4×5.8	D61	2.6
0.33	—	—	—	—	—	—	—	—	—	—	—	—	—	—	—	4×5.8	D61	3.2
0.47	—	—	—	—	—	—	—	—	—	—	—	—	—	—	—	4×5.8	D61	5.0
1	—	—	—	—	—	—	—	—	—	—	—	—	—	—	—	4×5.8	D61	10
2.2	—	—	—	—	—	—	—	—	—	—	—	—	—	—	—	4×5.8	D61	16
3.3	—	—	—	—	—	—	—	—	—	—	—	—	—	—	—	4×5.8	D61	17
4.7	—	—	—	—	—	—	—	—	—	—	—	—	4×5.8	D61	16	5×5.8	E61	23
10	—	—	—	—	—	—	4×5.8	D61	28	—	—	—	5×5.8	E61	28	6.3×5.8	F61	35
22	4×5.8	D61	26	—	—	—	5×5.8	E61	39	—	—	—	6.3×5.8	F61	55	6.3×7.7	F80	58
33	—	—	—	5×5.8	E61	43	—	—	—	6.3×5.8	F61	60	6.3×7.7	F80	57	8×10	G10	91
47	5×5.8	E61	46	—	—	—	6.3×5.8	F61	70	6.3×7.7	F80	65	—	—	—	8×10	G10	100
100	6.3×5.8	F61	71	—	—	—	6.3×7.7	F80	81	8×10	G10	130	—	—	—	10×10	H10	160
220	6.3×7.7	F80	101	8×10	G10	160	—	—	—	—	—	—	10×10	H10	220	—	—	—
330	8×10	G10	230	—	—	—	—	—	—	10×10	H10	238	—	—	—	—	—	—
470	—	—	—	—	—	—	10×10	H10	340	—	—	—	—	—	—	—	—	—
1000	10×10	H10	313	—	—	—	—	—	—	—	—	—	—	—	—	—	—	—

(Note) Rated ripple current : 105°C, 120Hz

Chip Type, 105°C Use, Long Life Capacitors

GREEN CAP

SMD

Low Z

105°C
2000hours

Anti-cleaning solvent

- Compatible with surface mounting.
- Supplied with carrier taping.
- Guarantees 2000 hours at 105°C.
(6.3 to 50V 10.5L:5000 hours)

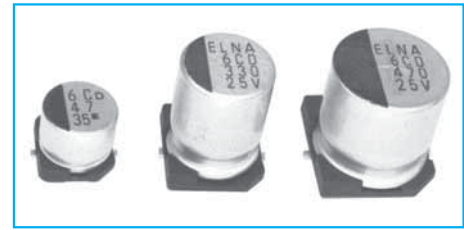
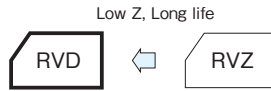

Marking color : Black print

Specifications

Item	Performance											
Category temperature range (°C)	-55 to +105											
Tolerance at rated capacitance (%)	±20 (20°C, 120Hz)											
Leakage current (µA)	Less than 0.01CV or 3 whichever is larger (after 2 minutes) C : Rated capacitance (µF), V : Rated voltage (V) (20°C)											
Tangent of loss angle (tanδ)	Rated voltage (V)	6.3	10	16	25	35	50	63	80	100		
	tanδ (max.)	0.26	0.19	0.16	0.14	0.12	0.10	0.08	0.08	0.07		
Characteristics at high and low temperature	Impedance ratio (max.)	Rated voltage (V)	6.3	10	16	25	35	50	63	80	100	
		Z-25°C/Z+20°C	2	2	2	2	2	2	2	2	2	
		Z-40°C/Z+20°C	3	3	3	3	3	3	3	3	3	
		Z-55°C/Z+20°C	8	4	4	3	3	3	3	3	3	
Endurance (105°C)	Test time	2000 hours (6.3 to 50V 10.5L : 5000 hours)										
	Leakage current	The initial specified value or less										
	Percentage of capacitance change	Within ±30% of initial value										
	Tangent of the loss angle	200% or less of initial specified value (6.3 to 50V 10.5L : 300% or less)										
Shelf life (105°C)	Test time : 1000 hours ; other items are the same as those for the endurance. Voltage application treatment : According to JIS C5101-1											
Applicable standards	JIS C 5101-1 1998, -18 1999(IEC 60384-1 1992, -18 1993)											

Outline Drawing

Unit : mm

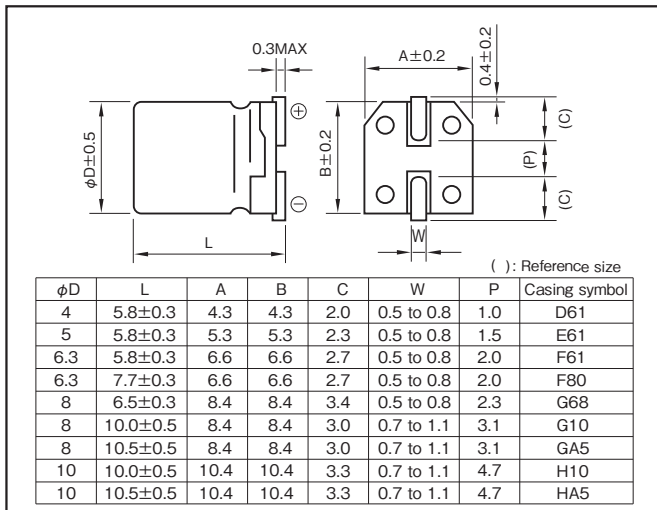

- Soldering conditions are described on page 13.
- Land pattern size are described on page 11.
- The taping specifications are described on page 14.

Coefficient of Frequency for Rated Ripple Current

Frequency (Hz)	50	120	1k	10k·100k
Rated voltage (V)				
6.3 to 100	0.5	0.5	0.75	1

Part numbering system (example : 16V100µF)

RVD	—	16	V	101	M	F61	U	—	()
Series code		Rated voltage symbol		Rated capacitance symbol	Capacitance tolerance symbol	Casing symbol			Taping symbol

In the case of "for High Temperature Reflow" type, a series name is "RZB".

Standard Ratings

Rated voltage (V)	Item	6.3				10				16			
		Case	Casing symbol	Impedance	Rated ripple current	Case	Casing symbol	Impedance	Rated ripple current	Case	Casing symbol	Impedance	Rated ripple current
		φDxL (mm)		(Ω max.)	(mArms)	φDxL (mm)		(Ω max.)	(mArms)	φDxL (mm)		(Ω max.)	(mArms)
10	-	-	-	-	-	-	-	-	-	4 X 5.8	D61	1.35	90
22	4 X 5.8	D61	1.35	90	4 X 5.8	D61	1.35	90	4 X 5.8	D61	1.35	90	
									5 X 5.8	E61	0.70	170	
33	-	-	-	-	4 X 5.8	D61	1.35	90	-	-	-	-	
					5 X 5.8	E61	0.70	170	-	-	-	-	
47	4 X 5.8	D61	1.35	90	-	-	-	-	5 X 5.8	E61	0.70	170	
	5 X 5.8	E61	0.70	170	-	-	-	-	6.3 X 5.8	F61	0.36	250	
100	5 X 5.8	E61	0.70	170	-	-	-	-	6.3 X 5.8	F61	0.36	250	
	6.3 X 5.8	F61	0.36	250	-	-	-	-	-	-	-	-	
220	6.3 X 5.8	F61	0.36	250	6.3 X 7.7	F80	0.30	300	6.3 X 7.7	F80	0.30	300	
					8 X 6.5	G68	0.30	300	8 X 6.5	G68	0.30	300	
330	6.3 X 7.7	F80	0.30	300	8 X 10	G10	0.16	600	8 X 10	G10	0.16	600	
	8 X 6.5	G68	0.30	300	8 X 10.5	GA5	0.16	600	8 X 10.5	GA5	0.16	600	
470	8 X 10	G10	0.16	600	8 X 10	G10	0.16	600	8 X 10	G10	0.16	600	
	8 X 10.5	GA5	0.16	600	8 X 10.5	GA5	0.16	600	8 X 10.5	GA5	0.16	600	
680	-	-	-	-	8 X 10	G10	0.16	600	10 X 10	H10	0.09	850	
					8 X 10.5	GA5	0.16	600	10 X 10.5	HA5	0.08	850	
1000	8 X 10	G10	0.16	600	10 X 10	H10	0.09	850	-	-	-	-	
	8 X 10.5	GA5	0.16	600	10 X 10.5	HA5	0.08	850	-	-	-	-	
1500	10 X 10	H10	0.09	850	-	-	-	-	-	-	-	-	
	10 X 10.5	HA5	0.08	850	-	-	-	-	-	-	-	-	

Rated voltage (V)	Item	25				35				50			
		Case	Casing symbol	Impedance	Rated ripple current	Case	Casing symbol	Impedance	Rated ripple current	Case	Casing symbol	Impedance	Rated ripple current
		φDxL (mm)		(Ω max.)	(mArms)	φDxL (mm)		(Ω max.)	(mArms)	φDxL (mm)		(Ω max.)	(mArms)
4.7	-	-	-	-	4 X 5.8	D61	1.35	90	4 X 5.8	D61	2.7	60	
10	4 X 5.8	D61	1.35	90	4 X 5.8	D61	1.35	90	5 X 5.8	E61	1.5	90	
					5 X 5.8	E61	0.70	170	6.3 X 5.8	F61	0.86	170	
22	5 X 5.8	E61	0.70	170	5 X 5.8	E61	0.70	170	6.3 X 5.8	F61	0.86	170	
									6.3 X 7.7	F80	0.66	195	
33	5 X 5.8	E61	0.70	170	6.3 X 5.8	F61	0.36	250	8 X 6.5	G68	0.63	200	
	6.3 X 5.8	F61	0.36	250					6.3 X 7.7	F80	0.66	195	
47	6.3 X 5.8	F61	0.36	250	6.3 X 5.8	F61	0.36	250	8 X 6.5	G68	0.63	200	
									6.3 X 7.7	F80	0.66	195	
100	6.3 X 7.7	F80	0.30	300	6.3 X 7.7	F80	0.30	300	8 X 10	G10	0.34	350	
	8 X 6.5	G68	0.30	300	8 X 10	G10	0.16	600	8 X 10.5	GA5	0.32	350	
220	8 X 10	G10	0.16	600	8 X 10.5	GA5	0.16	600	8 X 10.5	GA5	0.32	350	
	8 X 10.5	GA5	0.16	600	8 X 10	G10	0.16	600	10 X 10	H10	0.20	700	
330	8 X 10	G10	0.16	600	8 X 10.5	GA5	0.16	600	10 X 10.5	HA5	0.18	700	
	8 X 10.5	GA5	0.16	600	10 X 10	H10	0.09	850	-	-	-	-	
470	10 X 10	H10	0.09	850	10 X 10.5	HA5	0.08	850	-	-	-	-	
	10 X 10.5	HA5	0.08	850	-	-	-	-	-	-	-	-	

Rated voltage (V)	Item	63				80				100			
		Case	Casing symbol	Impedance	Rated ripple current	Case	Casing symbol	Impedance	Rated ripple current	Case	Casing symbol	Impedance	Rated ripple current
		φDxL (mm)		(Ω max.)	(mArms)	φDxL (mm)		(Ω max.)	(mArms)	φDxL (mm)		(Ω max.)	(mArms)
4.7	5 X 5.8	E61	3.0	50	-	-	-	-	-	-	-	-	
10	6.3 X 5.8	F61	1.5	80	6.3 X 7.7	F80	2.4	60	-	-	-	-	
22	6.3 X 7.7	F80	1.2	120	8 X 10	G10	0.90	130	8 X 10	G10	1.3	130	
					8 X 10.5	GA5	0.90	130	8 X 10.5	GA5	1.3	130	
33	8 X 10	G10	0.65	250	8 X 10	G10	0.90	130	10 X 10	H10	0.70	200	
	8 X 10.5	GA5	0.65	250	8 X 10.5	GA5	0.90	130	10 X 10.5	HA5	0.70	200	
47	8 X 10	G10	0.65	250	10 X 10	H10	0.50	200	-	-	-	-	
	8 X 10.5	GA5	0.65	250	10 X 10.5	HA5	0.50	200	-	-	-	-	
68	8 X 10	G10	0.65	250	-	-	-	-	-	-	-	-	
	8 X 10.5	GA5	0.65	250	-	-	-	-	-	-	-	-	
100	10 X 10	H10	0.35	400	-	-	-	-	-	-	-	-	
	10 X 10.5	HA5	0.35	400	-	-	-	-	-	-	-	-	

(Note) Impedance : 20°C, 100kHz
 Rated ripple current : 105°C, 100kHz

Chip Type, 105°C Use, Low Impedance Capacitors

GREEN CAP

SMD

Low Z

105°C
2000hours

Anti-cleaning solvent

- Compatible with surface mounting.
- Supplied with carrier taping.
- Guarantees 2000 hours at 105°C.

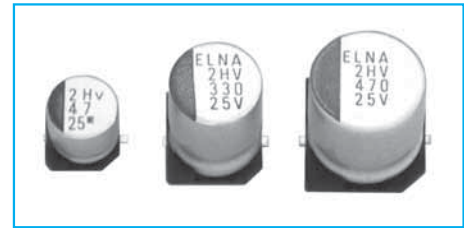
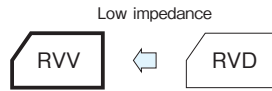

Marking color : Black print

Specifications

Item	Performance						
Category temperature range (°C)	-55 to +105						
Tolerance at rated capacitance (%)	±20 (20°C, 120Hz)						
Leakage current (µA)	Less than 0.01CV or 3 whichever is larger (after 2 minutes) C : Rated capacitance (µF) , V : Rated voltage (V) (20°C)						
Tangent of loss angle (tanδ)	Rated voltage (V)	6.3	10	16	25	35	
	tanδ (max.)	0.26	0.19	0.16	0.14	0.12	
Characteristics at high and low temperature	Impedance ratio (max.)	Rated voltage (V)	6.3	10	16	25	35
		Z-25°C/Z+20°C	2	2	2	2	2
		Z-40°C/Z+20°C	3	3	3	3	3
		Z-55°C/Z+20°C	8	4	4	3	3
Endurance (105°C)	Test time	2000 hours					
	Leakage current	The initial specified value or less					
	Percentage of capacitance change	Within ±30% of initial value					
	Tangent of the loss angle	200% or less of initial specified value					
Shelf life (105°C)	Test time : 1000 hours ; other items are the same as those for the endurance. Voltage application treatment : According to JIS C5101-1						
Applicable standards	JIS C 5101-1 1998, -18 1999(IEC 60384-1 1992, -18 1993)						

Outline Drawing

Unit : mm

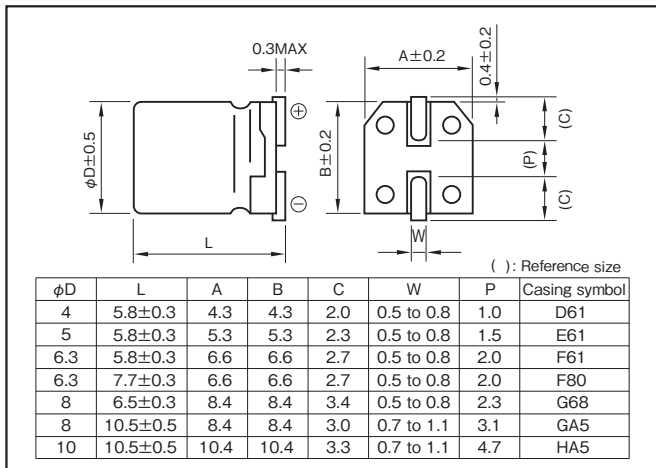

Coefficient of Frequency for Rated Ripple Current

Frequency (Hz)	50	120	1k	10k·100k
Rated voltage (V)				
6.3 to 35	0.5	0.5	0.75	1

Part numbering system (example : 16V100µF)

RVV	—	16	V	101	M	F61	U	□
Series code		Rated voltage symbol		Rated capacitance symbol	Capacitance tolerance symbol	Casing symbol		Taping symbol

- Soldering conditions are described on page 13.
- Land pattern size are described on page 11.
- The taping specifications are described on page 14.

NOTE

Design, Specifications are subject to change without notice. Ask factory for technical specifications before purchase and/or use.

Standard Ratings

Rated voltage (V)	Item	6.3				10				16			
		Case	Casing symbol	Impedance	Rated ripple current	Case	Casing symbol	Impedance	Rated ripple current	Case	Casing symbol	Impedance	Rated ripple current
		φD×L (mm)		(Ω max.)	(mArms)	φD×L (mm)		(Ω max.)	(mArms)	φD×L (mm)		(Ω max.)	(mArms)
10	—	—	—	—	—	—	—	—	—	—	—	—	—
22	4×5.8	D61	0.85	160	4×5.8	D61	0.85	160	4×5.8	D61	0.85	160	
	—	—	—	—	5×5.8	E61	0.36	240	5×5.8	E61	0.36	240	
33	—	—	—	—	4×5.8	D61	0.85	160	—	—	—	—	
	—	—	—	—	5×5.8	E61	0.36	240	—	—	—	—	
47	4×5.8	D61	0.85	160	—	—	—	—	5×5.8	E61	0.36	240	
	5×5.8	E61	0.36	240	—	—	—	—	6.3×5.8	F61	0.26	300	
100	5×5.8	E61	0.36	240	—	—	—	—	6.3×5.8	F61	0.26	300	
	6.3×5.8	F61	0.26	300	—	—	—	—	6.3×7.7	F80	0.16	600	
220	6.3×5.8	F61	0.26	300	6.3×7.7	F80	0.16	600	6.3×7.7	F80	0.16	600	
	—	—	—	—	8×6.5	G68	0.18	500	8×6.5	G68	0.18	500	
330	6.3×7.7	F80	0.16	600	—	—	—	—	8×10.5	GA5	0.08	850	
	8×6.5	G68	0.18	500	8×10.5	GA5	0.08	850	8×10.5	GA5	0.08	850	
470	8×10.5	GA5	0.08	850	8×10.5	GA5	0.08	850	8×10.5	GA5	0.08	850	
680	—	—	—	—	8×10.5	GA5	0.08	850	10×10.5	HA5	0.06	1190	
1000	8×10.5	GA5	0.08	850	10×10.5	HA5	0.06	1190	—	—	—	—	
1500	10×10.5	HA5	0.06	1190	—	—	—	—	—	—	—	—	

Rated voltage (V)	Item	25				35			
		Case	Casing symbol	Impedance	Rated ripple current	Case	Casing symbol	Impedance	Rated ripple current
		φD×L (mm)		(Ω max.)	(mArms)	φD×L (mm)		(Ω max.)	(mArms)
4.7	—	—	—	—	4×5.8	D61	0.85	160	
10	4×5.8	D61	0.85	160	4×5.8	D61	0.85	160	
	—	—	—	—	5×5.8	E61	0.36	240	
22	5×5.8	E61	0.36	240	5×5.8	E61	0.36	240	
33	5×5.8	E61	0.36	240	—	—	—	—	
	6.3×5.8	F61	0.26	300	6.3×5.8	F61	0.26	300	
47	6.3×5.8	F61	0.26	300	6.3×5.8	F61	0.26	300	
100	6.3×7.7	F80	0.16	600	6.3×7.7	F80	0.16	600	
	8×6.5	G68	0.18	500	8×10.5	GA5	0.08	850	
220	8×10.5	GA5	0.08	850	8×10.5	GA5	0.08	850	
330	8×10.5	GA5	0.08	850	10×10.5	HA5	0.06	1190	
470	10×10.5	HA5	0.06	1190	—	—	—	—	

(Note) Impedance : 20°C , 100kHz
 Rated ripple current : 105°C , 100kHz

Chip Type, 105°C Use, Low Impedance Capacitors

GREEN CAP

SMD

Low Impedance

105°C 2000hours

Anti-cleaning solvent

- Compatible with surface mounting.
- Supplied with carrier taping.
- Guarantees 2000 hours at 105°C.
($\phi 8 \times 6.5L$ or less : 1000hours)
($\phi 12.5 \times 13.5L$: 5000hours)

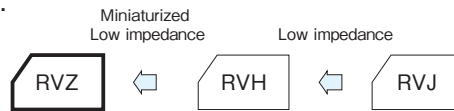

Marking color : Black print ($\phi 4 \times 5.3L - \phi 8 \times 6.5L, \phi 12.5 \times 13.5L$)
: White print on brown sleeve ($\phi 8 \times 10L - \phi 10 \times 10.5L$)

Specifications

Item	Performance						
Category temperature range (°C)	-55 to +105						
Tolerance at rated capacitance (%)	±20 (20°C, 120Hz)						
Leakage current (µA)	Less than 0.01CV or 3 whichever is larger (after 2 minutes) C : Rated capacitance (µF) ; V : Rated voltage (V) (20°C)						
Tangent of loss angle (tanδ)	Rated voltage (V)	6.3	10	16	25	35	
	tanδ (max.)	0.28	0.24	0.20	0.16	0.14	
Characteristics at high and low temperature	Rated voltage (V)	6.3	10	16	25	35	
	Impedance ratio (max.)	Z-25°C/Z+20°C	4	3	2	2	2
		Z-55°C/Z+20°C	8	5	4	3	3
Endurance (105°C) (Applied ripple current)	Test time	1000 hours ($\phi 8 \times 6.5L$ or less) 2000 hours ($\phi 8 \times 10L$ to $\phi 10 \times 10.5L$) 5000 hours ($\phi 12.5 \times 13.5L$)					
	Leakage current	The initial specified value or less					
	Percentage of capacitance change	Within ±25% of initial value					
	Tangent of the loss angle	200% or less of initial specified value					
Shelf life (105°C)	Test time : 1000 hours ; other items are the same as those for the endurance. Voltage application treatment : According to JIS C5101-1						
Applicable standards	JIS C5101-1 1998, -18 1999 (IEC 60384-1 1992, -18 1993)						

Outline Drawing

Unit : mm

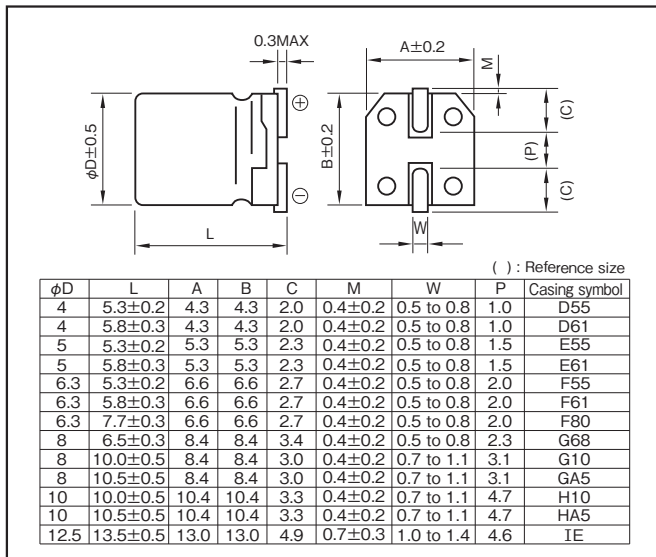

- Soldering conditions are described on page 13.
- Land pattern size are described on page 11.
- The taping specifications are described on page 14.

Coefficient of Frequency for Rated Ripple Current

Frequency (Hz)	120	1k	10k	100k	
Rated voltage (V)	6.3 to 35	0.5	0.75	0.9	1.0

Part numbering system

φ10×10.5L or less 6.3V1500µF

RVZ	6	V	152	M	HA5	U	
Series code	Rated voltage symbol	Rated capacitance symbol	Capacitance tolerance symbol	Capacitance tolerance symbol	Casing symbol	Taping symbol	

In the case of "for High Temperature Reflow" type, a series name is "RZA".

φ12.5×13.5L 6.3V2700µF

RVZ	6	V	272	M	IE	T	R5
Series code	Rated voltage symbol	Rated capacitance symbol	Capacitance tolerance symbol	Capacitance tolerance symbol	Casing symbol	Taping symbol	

NOTE

Design, Specifications are subject to change without notice.
Ask factory for technical specifications before purchase and/or use.

Standard Ratings

Rated voltage (V) Rated capacitance (μF) Item	6.3				10				16				25				35			
	Case	Casing symbol	Impedance (Ω)	Rated ripple current (mA rms)	Case	Casing symbol	Impedance (Ω)	Rated ripple current (mA rms)	Case	Casing symbol	Impedance (Ω)	Rated ripple current (mA rms)	Case	Casing symbol	Impedance (Ω)	Rated ripple current (mA rms)	Case	Casing symbol	Impedance (Ω)	Rated ripple current (mA rms)
	φD (mm)				φD (mm)				φD (mm)				φD (mm)				φD (mm)			
4.7	—	—	—	—	—	—	—	—	—	—	—	—	4×5.3	D55	3.20	65	4×5.3	D55	3.20	65
10	—	—	—	—	4×5.3	D55	3.20	65	4×5.3	D55	3.20	65	4×5.8	D61	1.80	80	5×5.3	E55	1.50	110
	—	—	—	—	—	—	—	—	—	—	—	—	5×5.3	E55	1.50	110	5×5.8	E61	0.76	150
15	—	—	—	—	—	—	—	—	4×5.8	D61	1.80	80	5×5.8	E61	0.76	150	5×5.8	E61	0.76	150
22	4×5.3	D55	3.20	65	4×5.8	D61	1.80	80	5×5.3	E55	1.50	110	5×5.8	E61	0.76	150	5×5.8	E61	0.76	150
	4×5.8	D61	1.80	80	5×5.3	E55	1.50	110	5×5.8	E61	0.76	150	6.3×5.3	F55	0.85	170	6.3×5.3	F55	0.85	170
33	5×5.3	E55	1.50	110	5×5.3	E55	1.50	110	6.3×5.3	F55	0.85	170	6.3×5.3	F55	0.85	170	6.3×5.3	F55	0.85	170
	5×5.8	E61	0.76	150	5×5.8	E61	0.76	150	6.3×5.8	F61	0.44	230	6.3×5.8	F61	0.44	230	6.3×5.8	F61	0.44	230
47	5×5.3	E55	1.50	110	6.3×5.3	F55	0.85	170	6.3×5.3	F55	0.85	170	6.3×5.3	F55	0.85	170	6.3×5.8	F61	0.44	230
	5×5.8	E61	0.76	150	6.3×5.8	F61	0.44	230	6.3×5.8	F61	0.44	230	6.3×5.8	F61	0.44	230	6.3×7.7	F80	0.34	280
68	6.3×5.8	F61	0.44	230	6.3×5.8	F61	0.44	230	6.3×5.8	F61	0.44	230	6.3×5.8	F61	0.44	230	8×6.5	G68	0.34	280
	6.3×5.3	F55	0.85	170	6.3×5.3	F55	0.85	170	6.3×5.3	F55	0.85	170	6.3×7.7	F80	0.34	280	8×6.5	G68	0.34	280
100	6.3×5.8	F61	0.44	230	6.3×5.8	F61	0.44	230	8×6.5	G68	0.34	280	8×6.5	G68	0.34	280	8×10.5	GA5	0.17	450
	6.3×5.8	F61	0.44	230	6.3×5.8	F61	0.44	230	6.3×7.7	F80	0.34	280	8×10	G10	0.20	450	8×10.5	GA5	0.17	450
150	6.3×5.8	F61	0.44	230	6.3×5.8	F61	0.44	230	8×6.5	G68	0.34	280	8×10.5	GA5	0.17	450	10×10	H10	0.10	670
	6.3×5.8	F61	0.44	230	6.3×7.7	F80	0.34	280	6.3×7.7	F80	0.34	280	8×10.5	GA5	0.17	450	8×10.5	GA5	0.17	450
220	6.3×7.7	F80	0.34	280	8×10	G10	0.20	450	8×10	G10	0.20	450	10×10	H10	0.10	670	10×10	H10	0.10	670
	6.3×7.7	F80	0.34	280	8×10.5	GA5	0.17	450	8×10.5	GA5	0.17	450	8×10.5	GA5	0.17	450	10×10.5	HA5	0.09	670
330	8×6.5	G68	0.34	200	10×10	H10	0.10	670	10×10	H10	0.10	670	10×10	H10	0.10	670	10×10.5	HA5	0.09	670
	8×10	G10	0.20	450	10×10	H10	0.10	670	10×10	H10	0.10	670	10×10.5	HA5	0.09	670	12.5×13.5	IE	0.06	1100
470	8×10.5	GA5	0.17	450	8×10.5	GA5	0.17	450	8×10.5	GA5	0.17	450	10×10.5	HA5	0.09	670	12.5×13.5	IE	0.06	1100
	10×10	H10	0.10	670	10×10	H10	0.10	670	10×10	H10	0.10	670	12.5×13.5	IE	0.06	1100	—	—	—	—
680	8×10.5	GA5	0.17	450	10×10.5	HA5	0.09	670	12.5×13.5	IE	0.06	1100	—	—	—	—	—	—	—	—
	10×10	H10	0.10	670	10×10.5	HA5	0.09	670	12.5×13.5	IE	0.06	1100	—	—	—	—	—	—	—	—
1000	8×10.5	GA5	0.17	450	10×10.5	HA5	0.09	670	12.5×13.5	IE	0.06	1100	—	—	—	—	—	—	—	—
	10×10	H10	0.10	670	12.5×13.5	IE	0.06	1100	—	—	—	—	—	—	—	—	—	—	—	—
1500	10×10.5	HA5	0.09	670	12.5×13.5	IE	0.06	1100	—	—	—	—	—	—	—	—	—	—	—	—
2200	12.5×13.5	IE	0.06	1100	—	—	—	—	—	—	—	—	—	—	—	—	—	—	—	—
2700	12.5×13.5	IE	0.06	1100	—	—	—	—	—	—	—	—	—	—	—	—	—	—	—	—

(Note) Rated ripple current : 105°C, 100kHz ; Impedance : 20°C, 100kHz

Chip Type, 125°C Use, Low ESR, Long Life Capacitors

GREEN CAP

SMD

125°C
2000hours

Anti-
cleaning
solvent

- Compatible with surface mounting.
- Supplied with carrier taping.
- Guarantees 2000 hours at 125°C.
($\phi 4$ to $\phi 8 \times 6.5L$: 1000h)

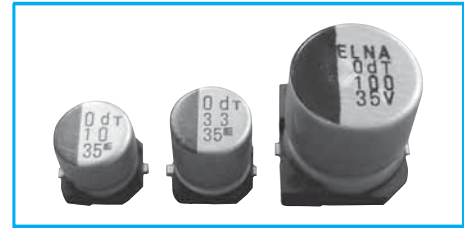

Marking color : Black print

Specifications

Item	Performance											
Category temperature range (°C)	-40 to +125											
Tolerance at rated capacitance (%)	±20 (20°C, 120Hz)											
Leakage current (µA)	Less than 0.01CV or 3 whichever is larger (after 2 minutes) C : Rated capacitance (µF) ; V : Rated voltage (V) (20°C)											
Tangent of loss angle	Rated voltage (V)	10	16	25	35	50	63	80	100			
	Tangent of loss angle	0.24	0.20	0.16	0.14	0.14	0.12	0.12	0.10	(20°C, 120Hz)		
Characteristics at high and low temperature	Impedance Ratio (max.)	Rated voltage (V)	10	16	25	35	50	63	80	100		
		Z-25°C/Z+20°C	3	2	2	2	2	2	2	2		
		Z-40°C/Z+20°C	4	3	3	3	3	3	3	(120Hz)		
Endurance (125°C)	Test time	2000 hours ($\phi 4$ to $\phi 8 \times 6.5L$: 1000h)										
	Leakage current	The initial specified value or less										
	Capacitance change	Within -30% to +30% of initial value										
	Tangent of loss angle	300% or less of the initial specified value										
Shelf life (125°C)	Test time : 1000 hours ; other items are the same as those for the endurance. Voltage application treatment : According to JIS C5101-1											
Applicable standards	JIS C5101-1 1998, -18 1999 (IEC 60384-1 1992, -18 1993)											

Outline Drawing

Unit : mm

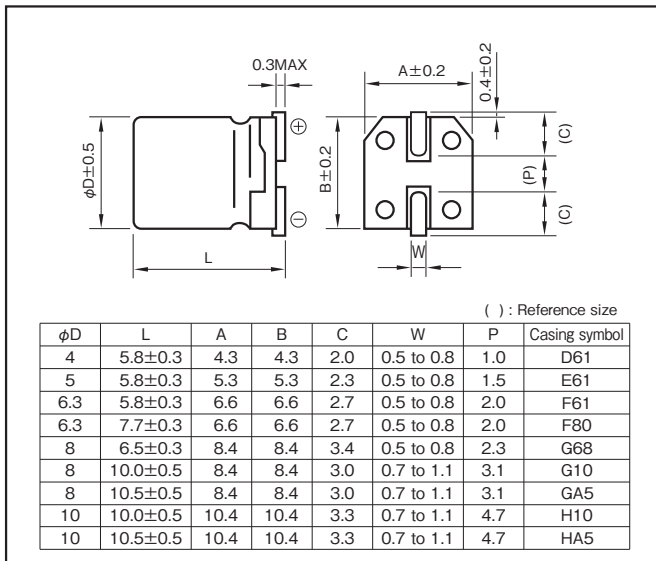

- Soldering conditions are described on page 13.
- Land pattern size are described on page 11.
- The taping specifications are described on page 14.

Coefficient of Frequency for Rated Ripple Current

Frequency (Hz)	120	1k	10k	100k
Rated voltage(V)				
10 to 100	0.77	0.88	0.96	1.00

Part numbering system (example : 35V220µF)

RVT	—	35	V	221	M	HA5	U	—	□
Series code		Rated voltage symbol		Rated capacitance symbol	Capacitance tolerance symbol	Casing symbol			Taping symbol

In the case of "for High Temperature Reflow" type, a series name is "RZC".

Standard Ratings

Rated voltage (V)	Item	10				16				25			
		Case	ESR (Ω max.)		Rated ripple current (mArms)	Case	ESR (Ω max.)		Rated ripple current (mArms)	Case	ESR (Ω max.)		Rated ripple current (mArms)
			φDxL (mm)	20°C			-40°C	φDxL (mm)			20°C	-40°C	
10	-	-	-	-	4 x 5.8	3.0	45	50	5 x 5.8	1.5	23	81	
22	4 x 5.8	3.0	45	50	5 x 5.8	1.5	23	81	6.3 x 5.8	1.0	15	114	
33	5 x 5.8	1.5	23	81	6.3 x 5.8	1.0	15	114	6.3 x 5.8	1.0	15	114	
47	-	-	-	-	6.3 x 5.8	1.0	15	114	6.3 x 7.7	0.60	9.0	165	
100	-	-	-	-	-	-	-	-	8 x 6.5	0.60	9.0	180	
									6.3 x 7.7	0.60	9.0	165	
									8 x 7.7	0.60	9.0	165	
									8 x 10	0.20	2.0	340	
220	6.3 x 7.7	0.60	9.0	165	8 x 10	0.20	2.0	340	8 x 10	0.20	2.0	340	
					8 x 10.5	0.20	2.0	340	8 x 10.5	0.20	2.0	340	
					10 x 10	0.15	1.5	500	10 x 10	0.15	1.5	500	
					10 x 10.5	0.15	1.5	500	10 x 10.5	0.15	1.5	500	
330	8 x 10	0.20	2.0	340	10 x 10	0.15	1.5	500	10 x 10	0.15	1.5	500	
					8 x 10.5	0.20	2.0	340	8 x 10.5	0.20	2.0	340	
					10 x 10	0.15	1.5	500	10 x 10	0.15	1.5	500	
					10 x 10.5	0.15	1.5	500	10 x 10.5	0.15	1.5	500	
470	10 x 10	0.15	1.5	500	-	-	-	-	-	-	-		
					10 x 10.5	0.15	1.5	500	-	-	-	-	-

Rated voltage (V)	Item	35				50				63						
		Case	ESR (Ω max.)		Rated ripple current (mArms)	Case	ESR (Ω max.)		Rated ripple current (mArms)	Case	ESR (Ω max.)		Rated ripple current (mArms)			
			φDxL (mm)	20°C			-40°C	φDxL (mm)			20°C	-40°C		φDxL (mm)	20°C	-40°C
4.7	4 x 5.8	3.0	45	50	-	-	-	-	-	-	-	-				
10	5 x 5.8	1.5	23	81	6.3 x 5.8	3.2	48	58	6.3 x 7.7	1.8	36	95				
	6.3 x 5.8	1.0	15	114												
22	6.3 x 5.8	1.0	15	114	6.3 x 7.7	1.2	18	95	8 x 10	0.70	14	140				
33	6.3 x 7.7	0.60	9.0	165	6.3 x 7.7	1.2	18	95	8 x 10.5	0.70	14	140				
									8 x 10	0.70	14	140				
									8 x 10.5	0.70	14	140				
									10 x 10	0.50	10	200				
47	8 x 6.5	0.60	9.0	180	8 x 10.5	0.50	7.5	180	10 x 10.5	0.50	10	200				
					6.3 x 7.7	0.60	9.0	165	8 x 10	0.70	14	140				
					8 x 10.5	0.20	2.0	340	8 x 10.5	0.70	14	140				
					8 x 10	0.20	2.0	340	10 x 10	0.30	4.5	280				
100	8 x 10	0.20	2.0	340	10 x 10	0.30	4.5	280	10 x 10.5	0.50	10	200				
													8 x 10.5	0.20	2.0	340
													10 x 10	0.15	1.5	500
													10 x 10.5	0.15	1.5	500
220	10 x 10	0.15	1.5	500	-	-	-	-	-	-	-	-				
					10 x 10.5	0.15	1.5	500	-	-	-	-	-	-		

Rated voltage (V)	Item	80				100			
		Case	ESR (Ω max.)		Rated ripple current (mArms)	Case	ESR (Ω max.)		Rated ripple current (mArms)
			φDxL (mm)	20°C			-40°C	φDxL (mm)	
10	8 x 10	0.75	15	110	8 x 10	0.75	15	110	
	8 x 10.5	0.75	15	110	8 x 10.5	0.75	15	110	
22	8 x 10	0.75	15	110	8 x 10	0.75	15	110	
	8 x 10.5	0.75	15	110	8 x 10.5	0.75	15	110	
	10 x 10	0.55	11	150	10 x 10	0.55	11	150	
	10 x 10.5	0.55	11	150	10 x 10.5	0.55	11	150	
33	8 x 10	0.75	15	110	10 x 10	0.55	11	150	
	8 x 10.5	0.75	15	110					
	10 x 10	0.55	11	150					
	10 x 10.5	0.55	11	150					

(Note) ESR : 20°C, 100kHz

Rated ripple current : 125°C, 100kHz

Chip Type 125°C Capacitors

GREEN CAP SMD 125°C 1250hours 105°C 5000hours Anti-cleaning solvent

- Compatible with surface mounting.
- Supplied with carrier taping.
- Guarantees 1250 hours at 125°C.
(φ8 : 1000 hours)
(φ12.5 : 5000 hours)
- Guarantees 5000 hours at 105°C.
(φ8 : 4000 hours)



High temperature

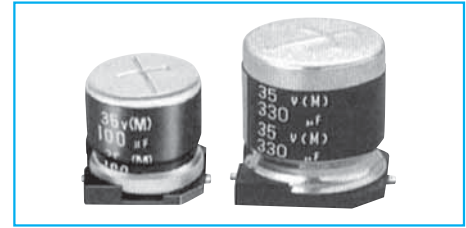

Marking color φ8, φ10 : Gold print on brown sleeve
φ12.5 : White print on brown sleeve

Specifications

Item	Performance								
Category temperature range (°C)	-40 to +125								
Tolerance at rated capacitance (%)	±20 (20°C, 120Hz)								
Leakage current (μA)	Less than 0.02CV or 3 whichever is larger (after 2 minutes) C : Rated capacitance (μF) ; V : Rated voltage (V) (20°C)								
Tangent of loss angle (tanδ)	Rated voltage (V)	10	16	25	35	50	63		
	tanδ (max.)	0.28	0.26	0.24	0.20	0.19	0.18	(20°C, 120Hz)	
Characteristics at high and low temperature	Rated voltage (V)	10	16	25	35	50	63		
	Impedance ratio (max.)	Z-25°C/Z+20°C	3	3	3	3	3	3	(120Hz)
Endurance (Applied ripple current)	Test temp.	125°C				105°C			
	Test time	φ8 : 1000h, φ10 : 1250h, φ12.5 : 5000h				φ8 : 4000h, φ10 : 5000h			
	Percentage of capacitance change	Within ±30% of initial value							
	Tangent of the loss angle	300% or less of the initial specified value							
Shelf life	Test temp.	125°C				105°C			
	Test time	500 h				1000h			
	Percentage of capacitance change	Within ±20% of initial value							
	Tangent of the loss angle	200% or less of the initial specified value							
Leakage current	The initial specified value or less								
Applicable standards	JIS C5101-1 1998, -18 1999 (IEC 60384-1 1992, -18 1993)								

Outline Drawing

Unit : mm

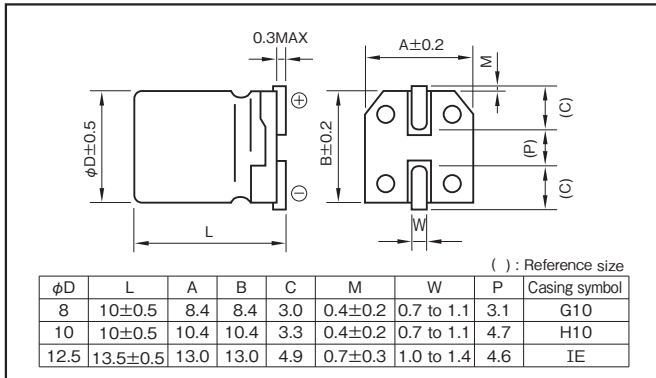

- Soldering conditions are described on page 13.
- Land pattern size are described on page 11.
- The taping specifications are described on page 14.

Standard Ratings

Rated voltage (V)	10				16				25				35				50				63			
	Case	Casing symbol	Impedance (Ω max.)	Rated ripple current (mA Arms)	Case	Casing symbol	Impedance (Ω max.)	Rated ripple current (mA Arms)	Case	Casing symbol	Impedance (Ω max.)	Rated ripple current (mA Arms)	Case	Casing symbol	Impedance (Ω max.)	Rated ripple current (mA Arms)	Case	Casing symbol	Impedance (Ω max.)	Rated ripple current (mA Arms)	Case	Casing symbol	Impedance (Ω max.)	Rated ripple current (mA Arms)
10	8×10	G10	0.68	60	8×10	G10	0.68	60	8×10	G10	0.68	60	8×10	G10	0.68	60	8×10	G10	0.80	38	8×10	G10	1.00	33
22	10×10	H10	0.55	111	10×10	H10	0.55	107	10×10	H10	0.55	107	10×10	H10	0.55	102	10×10	H10	0.65	45	10×10	H10	0.67	48
33	10×10	H10	0.55	111	10×10	H10	0.55	111	125×135	IE	0.105	579	125×135	IE	0.105	579	8×10	G10	0.80	40	10×10	H10	0.60	58
47	125×135	IE	0.105	579	125×135	IE	0.105	579	125×135	IE	0.105	579	125×135	IE	0.105	579	8×10	G10	0.68	55	10×10	H10	0.55	70
100	125×135	IE	0.105	579	125×135	IE	0.105	579	125×135	IE	0.105	579	125×135	IE	0.105	579	125×135	IE	0.60	58	125×135	IE	0.176	447
220	125×135	IE	0.105	579	125×135	IE	0.105	579	125×135	IE	0.105	579	125×135	IE	0.105	579	125×135	IE	0.60	58	125×135	IE	0.176	447
330	125×135	IE	0.105	579	125×135	IE	0.105	579	125×135	IE	0.105	579	125×135	IE	0.105	579	125×135	IE	0.60	58	125×135	IE	0.176	447
470	125×135	IE	0.105	579	125×135	IE	0.105	579	125×135	IE	0.105	579	125×135	IE	0.105	579	125×135	IE	0.60	58	125×135	IE	0.176	447
680	125×135	IE	0.105	579	125×135	IE	0.105	579	125×135	IE	0.105	579	125×135	IE	0.105	579	125×135	IE	0.60	58	125×135	IE	0.176	447
1000	125×135	IE	0.105	579	125×135	IE	0.105	579	125×135	IE	0.105	579	125×135	IE	0.105	579	125×135	IE	0.60	58	125×135	IE	0.176	447

(Note) Impedance : 20°C, 100kHz : Rated ripple current : 125°C, 100kHz

Coefficient of Frequency for Rated Ripple Current

Rated voltage (V)	Frequency (Hz)			
	120	1k	10k	100k
10 to 63	0.77	0.88	0.96	1

Rated capacitance (μF)	Frequency (Hz)			
	120	1k	10k	100k
100	0.40	0.75	0.90	1
220 to 330	0.50	0.85	0.95	1
470 to 1000	0.60	0.88	0.96	1

Part numbering system

φ8, φ10 (16V220μF)

RVK	16	V	221	M	H10	U	
Series code	Rated voltage symbol	Rated capacitance symbol	Capacitance tolerance symbol	Casing symbol	Taping symbol		

φ12.5 (10V470μF)

RVK	10	V	471	M	IE	T	R5
Series code	Rated voltage symbol	Rated capacitance symbol	Capacitance tolerance symbol	Casing symbol	Taping symbol		

Chip Type, 135°C Capacitors

GREEN CAP SMD 135°C 1000hours Anti-cleaning solvent

- Compatible with surface mounting.
- Supplied with carrier taping.
- Guarantees 1000 hours 135°C.

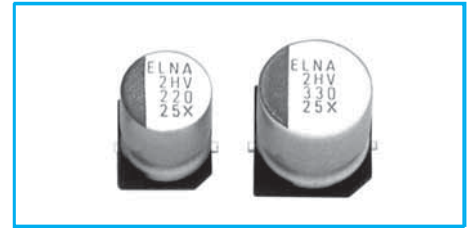
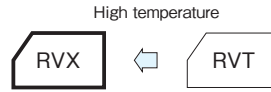

Marking color : Black print

Specifications

Item	Performance			
Category temperature range (°C)	-40 to +135			
Tolerance at rated capacitance (%)	±20 (20°C, 120Hz)			
Leakage current (µA)	Less than 0.01CV or 3 whichever is larger (after 2 minutes) C : Rated capacitance (µF) ; V : Rated voltage (V) (20°C)			
Tangent of loss angle (tanδ)	Rated voltage (V)	25	35	
	tanδ (max.)	0.24	0.20	
Characteristics at high and low temperature	Rated voltage (V)	25	35	
	Impedance Ratio (max.)	Z-25°C/Z+20°C	2	2
		Z-40°C/Z+20°C	3	3
Endurance (135°C)	Test time	1000 hours		
	Leakage current	The initial specified value or less		
	Percentage of Capacitance change	Within ±20% of initial value		
	Tangent of loss angle	300% or less of the initial specified value		
Shelf life (135°C)	Test time : 500 hours ; other items are the same as those for the endurance. Voltage application treatment			
Applicable standards	JIS C5101-1 1998, -18 1999 (IEC 60384-1 1992, -18 1993)			

Chip Type Aluminum Electrolytic Capacitors

Outline Drawing

Unit : mm

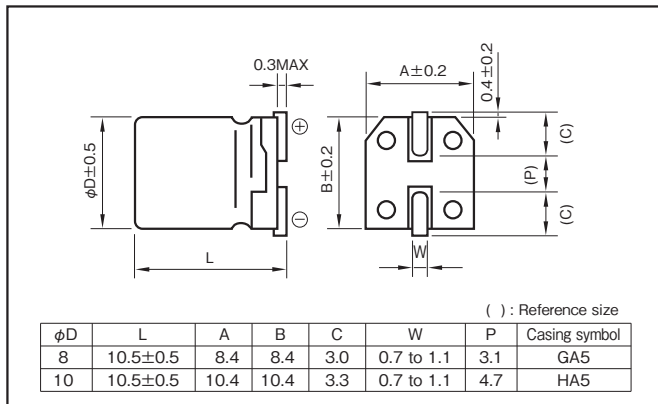

Coefficient of Frequency for Rated Ripple Current

Frequency (Hz)	120	1k	10k	100k
Rated voltage(V)				
25 to 35	0.77	0.88	0.96	1.00

Part numbering system (example : 35V220µF)

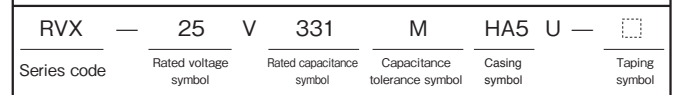

- Soldering conditions are described on page 13.
- Land pattern size are described on page 11.
- The taping specifications are described on page 14.

Standard Ratings

Rated voltage (V)	Item	25			35				
		Case	Casing symbol	ESR (Ω max.)	Rated ripple current (mArms)	Case	Casing symbol	ESR (Ω max.)	Rated ripple current (mArms)
22	—	—	—	—	—	—	—	—	—
	8×10.5	GA5	0.70	115	8×10.5	GA5	0.70	115	
33	10×10.5	HA5	0.50	155	10×10.5	HA5	0.50	155	
	8×10.5	GA5	0.70	115	8×10.5	GA5	0.70	115	
47	10×10.5	HA5	0.50	155	10×10.5	HA5	0.50	155	
	8×10.5	GA5	0.70	115	8×10.5	GA5	0.70	115	
100	10×10.5	HA5	0.50	155	10×10.5	HA5	0.50	155	
	8×10.5	GA5	0.70	115	8×10.5	GA5	0.70	115	
220	10×10.5	HA5	0.50	155	—	—	—	—	
	8×10.5	GA5	0.70	115	—	—	—	—	
330	10×10.5	HA5	0.50	155	—	—	—	—	

(Note) ESR : 20°C, 100kHz
Rated ripple current : 135°C, 100kHz

NOTE

Design, Specifications are subject to change without notice.
Ask factory for technical specifications before purchase and/or use.

Chip Type 105°C Use, Long Life Bipolar Capacitors

GREEN CAP

SMD

105°C
2000hours

Anti-cleaning solvent

- Compatible with surface mounting.
- Supplied with carrier taping.
- Guarantees 2000 hours 105°C.

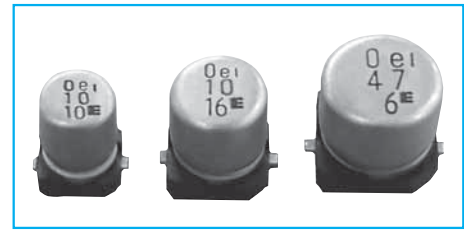
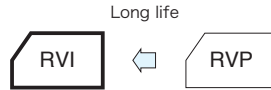

Marking color : Black print

Specifications

Item	Performance						
Category temperature range (°C)	-40 to +105						
Tolerance at rated capacitance (%)	±20 (20°C, 120Hz)						
Leakage current (µA)	Less than 0.01CV or 3 whichever is larger (after 2 minutes) C : Rated capacitance (µF), V : Rated voltage (V) (20°C)						
Tangent of loss angle (tanδ)	Rated voltage (V)	6.3	10	16	25	35	50
	tanδ (max.)	0.30	0.22	0.16	0.14	0.12	0.12
Characteristics at high and low temperature	Impedance ratio (max.)	Z-25°C/Z+20°C	4	3	2	2	2
		Z-40°C/Z+20°C	8	6	4	4	3
Endurance (105°C)	Test time	2000 hours (with the polarity inverted every 250 hours)					
	Leakage current	The initial specified value or less					
	Percentage of capacitance change	Within ±20% of initial value					
	Tangent of loss angle	200% or less of the initial specified value					
Shelf life (105°C)	Test time : 1000 hours ; other items are the same as those for the endurance. Voltage application treatment						
Applicable standards	JIS C5101-1 1998, -18 1999 (IEC 60384-1 1992, -18 1993)						

Outline Drawing

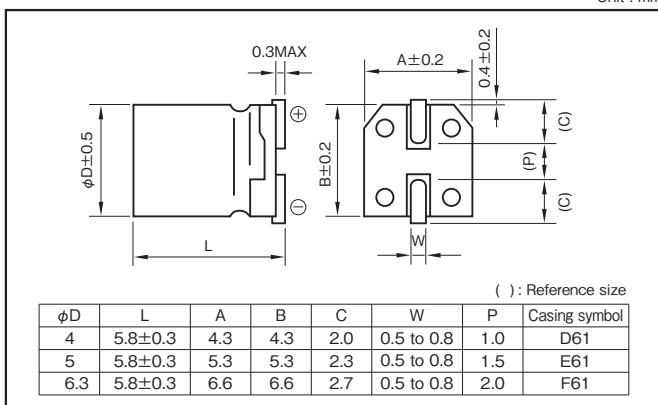

Coefficient of Frequency for Rated Ripple Current

Rated voltage (V)	Frequency (Hz)			
	50 · 60	120	1k	10k · 100k
6.3 to 16	0.80	1.00	1.15	1.25
25 to 35	0.80	1.00	1.25	1.40
50	0.1 to 3.3µF	0.50	1.00	1.35
	4.7µF	0.70	1.00	1.35

Part numbering system (example : 6.3V47µF)

RVI	—	6	V	470	M	F61	U	□
Series code		Rated voltage symbol		Rated capacitance symbol	Capacitance tolerance symbol	Casing symbol		Taping symbol

- Soldering conditions are described on page 13.
- Land pattern size are described on page 11.
- The taping specifications are described on page 14.

Standard Ratings

Rated capacitance (µF)	6.3		10		16		25		35		50	
	Case	Rated ripple current (mArms)	Case	Rated ripple current (mArms)	Case	Rated ripple current (mArms)	Case	Rated ripple current (mArms)	Case	Rated ripple current (mArms)	Case	Rated ripple current (mArms)
0.22	—	—	—	—	—	—	—	—	—	—	4	3
0.33	—	—	—	—	—	—	—	—	—	—	4	3
0.47	—	—	—	—	—	—	—	—	—	—	4	5
1	—	—	—	—	—	—	—	—	—	—	4	10
2.2	—	—	—	—	—	—	—	—	4	10	—	—
3.3	—	—	—	—	—	—	4	12	—	—	5	17
											6.3	20
4.7	—	—	—	—	—	—	4	12	—	—	6.3	23
10	—	—	4	20	5	25	6.3	28	—	—	—	—
22	—	—	—	—	—	—	6.3	55	—	—	—	—
33	—	—	6.3	41	—	—	—	—	—	—	—	—
47	6.3	45	—	—	—	—	—	—	—	—	—	—

(Note) Rated ripple current : 105°C, 120Hz

Chip Type, 105°C Use, Large Capacitance Capacitors

SMD Vibration Resistance 105°C 2000hours Anti-cleaning solvent

- Compatible with surface mounting.
- For Vibration resistance.
- Supplied with carrier taping.
- Guarantees 2000 hours at 105°C.

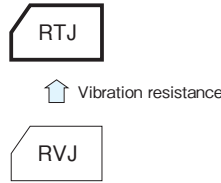

Marking color : White print on a brown sleeve

Specifications

Item	Performance										
Category temperature range (°C)	-55 to +105										
Tolerance at rated capacitance (%)	±20 (20°C, 120Hz)										
Leakage current (µA)	Less than 0.01CV or 3 whichever is larger (after 2 minutes) C : Rated capacitance (µF) ; V : Rated voltage (V) (20°C)										
Tangent of loss angle (tanδ)	Rated voltage (V)	6.3	10	16	25	35	50	63	100		
	tanδ (max.)	0.30	0.26	0.22	0.16	0.13	0.12	0.11	0.10	(20°C, 120Hz)	
Characteristics at high and low temperature	Impedance ratio (max.)	Rated voltage (V)	6.3	10	16	25	35	50	63	100	
		Z-25°C/Z+20°C	4	3	2	2	2	2	2	2	(120Hz)
Endurance (105°C) (Applied ripple current)	Test time	2000 hours									
	Leakage current	The initial specified value or less									
	Percentage of capacitance change	Within ±20% of initial value									
	Tangent of the loss angle	200% or less of the initial specified value									
Shelf life (105°C)	Test time : 1000 hours; other items are the same as those for the endurance. Voltage application treatment : According to JIS C5101-1										
Applicable standards	JIS C5101-1 1998, -18 1999 (IEC 60384-1 1992, -18 1993)										

Aluminum Electrolytic Capacitors

Outline Drawing

Unit : mm

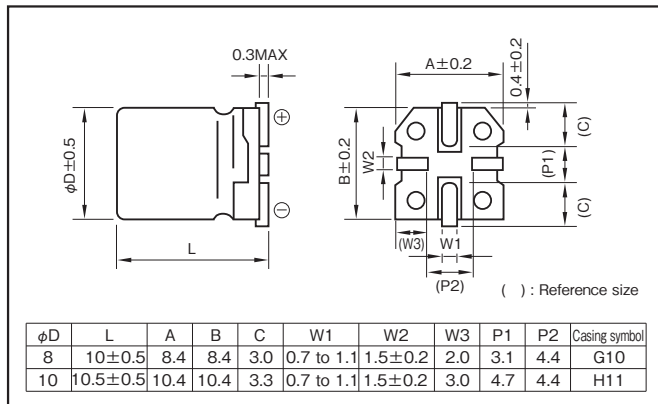

Coefficient of Frequency for Rated Ripple Current

Rated voltage (V)	Frequency (Hz)			
	50 · 60	120	1k	10k · 100k
6.3 to 16	0.80	1	1.15	1.25
25 to 35	0.80	1	1.25	1.40
50 to 63	0.80	1	1.35	1.50
100	0.70	1	1.35	1.50

Part numbering system (example: 25V220µF)

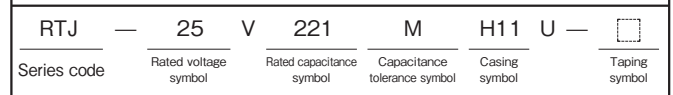

- Soldering conditions are described on page 13.
- Land pattern size are described on page 11.
- The taping specifications are described on page 14.

Standard Ratings

Rated voltage (V)	6.3			10			16			25			35			50			63			100											
	Case	Casing symbol	Rated ripple current	Case	Casing symbol	Rated ripple current	Case	Casing symbol	Rated ripple current	Case	Casing symbol	Rated ripple current	Case	Casing symbol	Rated ripple current	Case	Casing symbol	Rated ripple current	Case	Casing symbol	Rated ripple current	Case	Casing symbol	Rated ripple current									
Rated capacitance (µF)	ϕD(mm)	Symbol	(Ω)	ϕD(mm)	Symbol	(Ω)	ϕD(mm)	Symbol	(Ω)	ϕD(mm)	Symbol	(Ω)	ϕD(mm)	Symbol	(Ω)	ϕD(mm)	Symbol	(Ω)	ϕD(mm)	Symbol	(Ω)	ϕD(mm)	Symbol	(Ω)									
10	—	—	—	—	—	—	—	—	—	—	—	—	—	—	—	—	—	—	—	—	—	—	—	—									
22	—	—	—	—	—	—	—	—	—	—	—	—	—	—	—	—	—	—	—	—	—	—	—	—									
33	—	—	—	—	—	—	—	—	—	—	—	—	—	—	—	—	—	—	—	—	—	—	—	—									
47	—	—	—	—	—	—	—	—	—	—	—	—	—	—	—	8×10	G10	4.6	178	8×10	G10	4.2	178	10×10.5	H11	5.5	160	—	—	—	—	—	—
100	—	—	—	—	—	—	—	—	—	8×10	G10	3.6	178	8×10	G10	2.7	178	10×10.5	H11	2.2	324	10×10.5	H11	2.0	324	—	—	—	—	—	—	—	—
220	8×10	G10	2.3	178	8×10	G10	2.0	178	10×10.5	H11	1.7	324	10×10.5	H11	1.2	324	10×10.5	H11	0.98	324	—	—	—	—	—	—	—	—	—	—	—	—	—
330	8×10	G10	1.5	178	10×10.5	H11	1.3	324	10×10.5	H11	1.1	324	10×10.5	H11	0.80	324	—	—	—	—	—	—	—	—	—	—	—	—	—	—	—	—	—
470	10×10.5	H11	1.0	324	10×10.5	H11	0.92	324	10×10.5	H11	0.78	324	—	—	—	—	—	—	—	—	—	—	—	—	—	—	—	—	—	—	—	—	—

(Note) Rated ripple current : 105°C, 120Hz ; ESR : 20°C, 120Hz

NOTE

Design, Specifications are subject to change without notice.
Ask factory for technical specifications before purchase and/or use.

Chip Type 125°C Capacitors

- SMD
- Vibration Resistance
- 125°C 1250hours
- 105°C 5000hours
- Anti-cleaning solvent

- Compatible with surface mounting.
- For Vibration resistance.
- Supplied with carrier taping.
- Guarantees 1250 hours at 125°C. (φ8 : 1000 hours)
- Guarantees 5000 hours at 105°C. (φ8 : 4000 hours)



↑ Vibration resistance



Marking color : Gold print on a brown sleeve

Specifications

Item	Performance								
Category temperature range (°C)	-40 to +125								
Tolerance at rated capacitance (%)	±20 (20°C,120Hz)								
Leakage current (μA)	Less than 0.02CV or 3 whichever is larger (after 2 minutes) C : Rated capacitance (μF) ; V : Rated voltage (V) (20°C)								
Tangent of loss angle (tanδ)	Rated voltage (V)	10	16	25	35	50	63		
	tanδ (max.)	0.28	0.26	0.24	0.20	0.19	0.18	(20°C,120Hz)	
Characteristics at high and low temperature	Rated voltage (V)	10	16	25	35	50	63		
	Impedance ratio (max.)	Z-25°C/Z+20°C	3	3	3	3	3	3	
		Z-40°C/Z+20°C	5	5	5	5	5	5	(120Hz)
Endurance (Applied ripple current)	Test temp.	125°C				105°C			
	Test time	φ10 : 1250h, φ8 : 1000h				φ10 : 5000h, φ8 : 4000h			
	Percentage of capacitance change	Within ±30% of initial value							
	Tangent of the loss angle	300% or less of the initial specified value							
	Leakage current	The initial specified value or less							
Shelf life	Test temp.	125°C				105°C			
	Test time	500 h				1000h			
	Percentage of capacitance change	Within ±20% of initial value							
	Tangent of the loss angle	200% or less of the initial specified value							
	Leakage current	The initial specified value or less							
Applicable standards	JIS C5101-1 1998, -18 1999 (IEC 60384-1 1992, -18 1993)								

Outline Drawing

Unit : mm

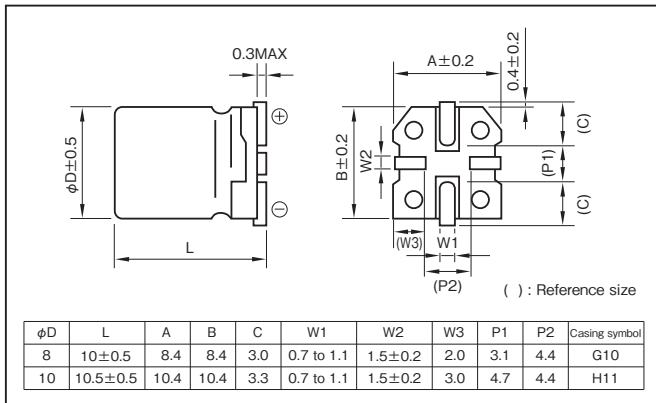

- Soldering conditions are described on page 13.
- Land pattern size are described on page 11.
- The taping specifications are described on page 14.

Coefficient of Frequency for Rated Ripple Current

Frequency (Hz)	120	1k	10k	100k
Rated voltage (V)				
10 to 63	0.77	0.88	0.96	1

Part numbering system (example : 16V220μF)

RTK	—	16	V	221	M	H11	U	□
Series code		Rated voltage symbol		Rated capacitance symbol	Capacitance tolerance symbol	Casing symbol		Taping symbol

Standard Ratings

Rated voltage (V)	10				16				25				35				50				63			
	Case	ESR	Impedance	Rated ripple current	Case	ESR	Impedance	Rated ripple current	Case	ESR	Impedance	Rated ripple current	Case	ESR	Impedance	Rated ripple current	Case	ESR	Impedance	Rated ripple current	Case	ESR	Impedance	Rated ripple current
Rated capacitance (μF)	φD×L(mm)	(Ω)	(Ω max.)	(mArms)	φD×L(mm)	(Ω)	(Ω max.)	(mArms)	φD×L(mm)	(Ω)	(Ω max.)	(mArms)	φD×L(mm)	(Ω)	(Ω max.)	(mArms)	φD×L(mm)	(Ω)	(Ω max.)	(mArms)	φD×L(mm)	(Ω)	(Ω max.)	(mArms)
10	—	—	—	—	—	—	—	—	—	—	—	—	—	—	—	—	8×10	32	0.80	38	—	—	—	—
																	10×10.5	32	0.65	45	—	—	—	—
22	—	—	—	—	—	—	—	—	—	—	—	—	—	—	—	—	8×10	14	0.80	38	8×10	14	1.00	33
																	10×10.5	14	0.65	48	10×10.5	14	0.67	48
33	—	—	—	—	—	—	—	—	—	—	—	—	—	—	—	—	8×10	10	0.80	40	—	—	—	—
																	10×10.5	10	0.60	58	—	—	—	—
47	—	—	—	—	—	—	—	—	—	—	—	—	—	—	—	—	8×10	7.1	0.68	65	8×10	6.7	0.80	40
																	10×10.5	7.1	0.58	70	10×10.5	6.7	0.60	58
100	—	—	—	—	8×10	4.3	0.68	60	8×10	4.0	0.68	60	10×10.5	3.3	0.55	102	—	—	—	—	—	—	—	—
																	8×10	2.1	0.68	60	10×10.5	2.0	0.55	107
220	—	—	—	—	—	—	—	—	—	—	—	—	—	—	—	—	10×10.5	2.1	0.55	111	—	—	—	—
																	10×10.5	2.1	0.55	111	—	—	—	—
330	—	—	—	—	—	—	—	—	—	—	—	—	—	—	—	—	10×10.5	1.4	0.55	111	—	—	—	—
																	10×10.5	1.3	0.55	111	—	—	—	—

(Note) Impedance : 20°C, 100kHz ; Rated ripple current : 125°C, 100kHz ; ESR : 20°C, 120Hz

NOTE

Design, Specifications are subject to change without notice. Ask factory for technical specifications before purchase and/or use.

Chip Type 105°C Use, Low Impedance Capacitors

GREEN CAP SMD Low Impedance 105°C 2000hours Anti-cleaning solvent

- Compatible with surface mounting.
- For Vibration resistance.
- Supplied with carrier taping.
- Guarantees 2000 hours at 105°C. (φ12.5 to φ18 : 5000hours)

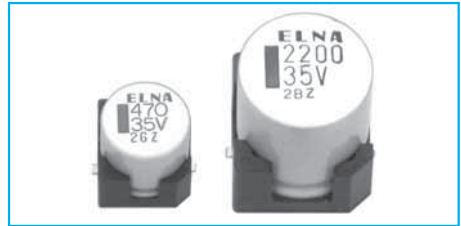

Marking color : Black print

Specifications

Item	Performance						
Category temperature range (°C)	-55 to +105						
Tolerance at rated capacitance (%)	±20 (20°C,120Hz)						
Leakage current (μA)	Less than 0.01CV or 3 whichever is larger (after 2 minutes) C : Rated capacitance (μF) , V : Rated voltage (V) (20°C)						
Tangent of loss angle (tanδ)	Rated voltage (V)	6.3	10	16	25	35	
	tanδ (max.)	0.28	0.24	0.20	0.16	0.14	
0.02 is added to every 1000μF increase over 1000μF (20°C,120Hz)							
Characteristics at high and low temperature	Impedance ratio (max.)	Rated voltage (V)	6.3	10	16	25	35
		Z-25°C/Z+20°C	4	3	2	2	2
		Z-55°C/Z+20°C	8	5	4	3	3
(120Hz)							
Endurance (105°C) (Applied ripple current)	Test time	2000 hours (φ8, 10) 5000 hours (φ12.5 to 18)					
	Leakage current	The initial specified value or less					
	Percentage of capacitance change	Within ±25% of initial value					
	Tangent of loss angle	200% or less of the initial specified value					
Shelf life (105°C)	Test time : 1000 hours ; other items are the same as those for the endurance. Voltage application treatment : According to JIS C5101-1						
Applicable standards	JIS C5101-1 1998, -18 1999 (IEC 60384-1 1992, -18 1993)						

Chip Type Aluminum Electrolytic Capacitors

Outline Drawing

φD	L	A	B	C	W	P	M	Casing symbol
8	10.0±0.5	8.4	8.4	3.0	0.7 to 1.1	3.1	0.4±0.2	G10
8	10.5±0.5	8.4	8.4	3.0	0.7 to 1.1	3.1	0.4±0.2	GA5
10	10.0±0.5	10.4	10.4	3.3	0.7 to 1.1	4.7	0.4±0.2	H10
10	10.5±0.5	10.4	10.4	3.3	0.7 to 1.1	4.7	0.4±0.2	HA5
12.5	13.5±0.5	13	13	4.9	1.0 to 1.4	4.6	0.7±0.3	IE
12.5	16.0±0.5	13	13	4.9	1.0 to 1.4	4.6	0.7±0.3	IH
16	16.5±0.5	17	17	5.6	1.0 to 1.4	7.2	0.7±0.3	JH
16	21.5±0.5	17	17	5.6	1.0 to 1.4	7.2	0.7±0.3	JM
18	16.5±0.5	19	19	6.6	1.0 to 1.4	7.2	0.7±0.3	KH
18	21.5±0.5	19	19	6.6	1.0 to 1.4	7.2	0.7±0.3	KM

Coefficient of Frequency for Rated Ripple Current

Frequency (Hz)	120	1k	10k	100k	
Rated voltage (V)	6.3 to 35	0.5	0.75	0.9	1.0

Part numbering system

φ8, φ10 (6.3V1500μF)

RTZ — 6 V 152 M HA5 SU — □

Series code Rated voltage symbol Rated capacitance symbol Capacitance tolerance symbol Casing symbol Taping symbol

φ12.5 or more (6.3V2200μF)

RTZ — 6 V 222 M IE T — □

Series code Rated voltage symbol Rated capacitance symbol Capacitance tolerance symbol Casing symbol Taping symbol

- Soldering conditions are described on page 13.
- Land pattern size are described on page 11.
- The taping specifications are described on page 14.

Standard Ratings

Rated voltage (V)	Item	6.3				10				16				25				35			
		Case	Casing symbol	Impedance (Ω max.)	Rated ripple current (mA Arms)	Case	Casing symbol	Impedance (Ω max.)	Rated ripple current (mA Arms)	Case	Casing symbol	Impedance (Ω max.)	Rated ripple current (mA Arms)	Case	Casing symbol	Impedance (Ω max.)	Rated ripple current (mA Arms)	Case	Casing symbol	Impedance (Ω max.)	Rated ripple current (mA Arms)
150	—	—	—	—	—	—	—	—	—	—	—	—	—	—	—	—	—	8×10.5	GA5	0.17	450
220	—	—	—	—	—	—	—	—	—	8×10	G10	0.20	450	8×10.5	GA5	0.17	450	8×10.5	GA5	0.17	450
330	—	—	—	—	—	—	—	—	—	10×10	H10	0.10	670	10×10	H10	0.10	670	10×10	H10	0.10	670
470	8×10.5	GA5	0.17	450	10×10	H10	0.10	670	10×10	H10	0.10	670	10×10	H10	0.10	670	10×10.5	HA5	0.090	670	
680	8×10.5	GA5	0.17	450	10×10	HA5	0.090	670	10×10.5	HA5	0.090	670	12.5×13.5	IE	0.060	1100	12.5×13.5	IE	0.060	1100	
1000	8×10.5	GA5	0.17	450	10×10	HA5	0.090	670	12.5×13.5	IE	0.060	1100	12.5×13.5	IE	0.060	1100	16×16.5	JH	0.046	1540	
1500	10×10.5	HA5	0.090	670	12.5×13.5	IE	0.060	1100	12.5×13.5	IE	0.060	1100	16×21.5	JM	0.040	1840	16×16.5	JH	0.046	1540	
2200	12.5×13.5	IE	0.060	1100	16×16.5	JH	0.046	1540	16×16.5	JH	0.046	1540	18×16.5	KH	0.042	1760	18×16.5	KH	0.042	1760	
3300	16×16.5	JH	0.046	1540	12.5×13.5	IE	0.060	1100	16×16.5	JH	0.046	1540	18×16.5	KH	0.042	1760	18×21.5	JM	0.040	1840	
4700	16×16.5	JH	0.046	1540	16×21.5	JM	0.040	1840	16×21.5	JM	0.040	1840	18×21.5	KM	0.038	1960	18×16.5	KH	0.042	1760	
6800	18×21.5	KM	0.038	1960	18×16.5	KH	0.042	1760	18×16.5	KH	0.042	1760	—	—	—	—	—	—	—	—	—
8200	18×21.5	KM	0.038	1960	—	—	—	—	—	—	—	—	—	—	—	—	—	—	—	—	—

(Note) Rated ripple current : 105°C , 100kHz, Impedance : 20°C , 100kHz

NOTE Design, Specifications are subject to change without notice. Ask factory for technical specifications before purchase and/or use.

Chip Type 105°C Use, Long Life Capacitors

GREEN CAP

SMD

Low Impedance

105°C 5000hours

Anti-cleaning solvent

- Compatible with surface mounting.
- For Vibration resistance.
- Supplied with carrier taping.
- Guarantees 5000 hours at 105°C.

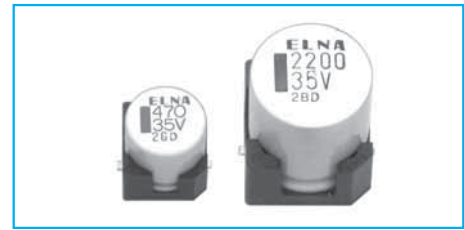
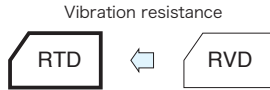

Marking color : Black print

Specifications

Item	Performance																																						
Category temperature range (°C)	-55 to +105																																						
Tolerance at rated capacitance (%)	±20 (20°C, 120Hz)																																						
Leakage current (µA)	Less than 0.01CV or 3 whichever is larger (after 2 minutes) C : Rated capacitance (µF) , V : Rated voltage (V) (20°C)																																						
Tangent of loss angle (tanδ)	<table border="1"> <tr> <th>Rated voltage (V)</th> <td>6.3</td> <td>10</td> <td>16</td> <td>25</td> <td>35</td> <td>50</td> <td>63</td> <td>80</td> <td>100</td> </tr> <tr> <th>tanδ (max.)</th> <td>0.26</td> <td>0.19</td> <td>0.16</td> <td>0.14</td> <td>0.12</td> <td>0.1</td> <td>0.08</td> <td>0.08</td> <td>0.07</td> </tr> </table>	Rated voltage (V)	6.3	10	16	25	35	50	63	80	100	tanδ (max.)	0.26	0.19	0.16	0.14	0.12	0.1	0.08	0.08	0.07																		
	Rated voltage (V)	6.3	10	16	25	35	50	63	80	100																													
tanδ (max.)	0.26	0.19	0.16	0.14	0.12	0.1	0.08	0.08	0.07																														
0.02 is added to every 1000µF increase over 1000µF (20°C, 120Hz)																																							
Characteristics at high and low temperature	<table border="1"> <tr> <th>Rated voltage (V)</th> <td>6.3</td> <td>10</td> <td>16</td> <td>25</td> <td>35</td> <td>50</td> <td>63</td> <td>80</td> <td>100</td> </tr> <tr> <th rowspan="3">Impedance ratio (max.)</th> <td>Z-25°C/Z+20°C</td> <td>2</td> <td>2</td> <td>2</td> <td>2</td> <td>2</td> <td>2</td> <td>2</td> <td>2</td> </tr> <tr> <td>Z-40°C/Z+20°C</td> <td>3</td> <td>3</td> <td>3</td> <td>3</td> <td>3</td> <td>3</td> <td>3</td> <td>3</td> </tr> <tr> <td>Z-55°C/Z+20°C</td> <td>8</td> <td>4</td> <td>4</td> <td>3</td> <td>3</td> <td>3</td> <td>3</td> <td>3</td> </tr> </table>	Rated voltage (V)	6.3	10	16	25	35	50	63	80	100	Impedance ratio (max.)	Z-25°C/Z+20°C	2	2	2	2	2	2	2	2	Z-40°C/Z+20°C	3	3	3	3	3	3	3	3	Z-55°C/Z+20°C	8	4	4	3	3	3	3	3
	Rated voltage (V)	6.3	10	16	25	35	50	63	80	100																													
	Impedance ratio (max.)	Z-25°C/Z+20°C	2	2	2	2	2	2	2	2																													
Z-40°C/Z+20°C		3	3	3	3	3	3	3	3																														
Z-55°C/Z+20°C		8	4	4	3	3	3	3	3																														
(120Hz)																																							
Endurance (105°C)	Test time	5000 hours																																					
	Leakage current	The initial specified value or less																																					
	Percentage of capacitance change	Within ±30% of initial value																																					
	Tangent of loss angle	300% or less of the initial specified value																																					
Shelf life (105°C)	Test time : 1000 hours ; other items are the same as those for the endurance. Voltage application treatment : According to JIS C5101-1																																						
Applicable standards	JIS C5101-1 1998, -18 1999 (IEC 60384-1 1992, -18 1993)																																						

Outline Drawing

Unit : mm

φD±0.5, L, A±0.2, B±0.2, C, W, P, M, () : Reference size

φD	L	A	B	C	W	P	M	Casing symbol
8	10.0±0.5	8.4	8.4	3.0	0.7 to 1.1	3.1	0.4±0.2	G10
8	10.5±0.5	8.4	8.4	3.0	0.7 to 1.1	3.1	0.4±0.2	GA5
10	10.0±0.5	10.4	10.4	3.3	0.7 to 1.1	4.7	0.4±0.2	H10
10	10.5±0.5	10.4	10.4	3.3	0.7 to 1.1	4.7	0.4±0.2	HA5
12.5	13.5±0.5	13	13	4.9	1.0 to 1.4	4.6	0.7±0.3	IE
12.5	16.0±0.5	13	13	4.9	1.0 to 1.4	4.6	0.7±0.3	IH
16	16.5±0.5	17	17	5.6	1.0 to 1.4	7.2	0.7±0.3	JH
16	21.5±0.5	17	17	5.6	1.0 to 1.4	7.2	0.7±0.3	JM
18	16.5±0.5	19	19	6.6	1.0 to 1.4	7.2	0.7±0.3	KH
18	21.5±0.5	19	19	6.6	1.0 to 1.4	7.2	0.7±0.3	KM

Coefficient of Frequency for Rated Ripple Current

Frequency (Hz)	120	1k	10k	100k
Rated voltage (V)	120	1k	10k	100k
6.3 to 100	0.5	0.75	0.9	1.0

Part numbering system

φ8, φ10 (6.3V1500µF)

RTD — 6 V 152 M HA5 SU — □

Series code Rated voltage symbol Rated capacitance symbol Capacitance tolerance symbol Casing symbol Taping symbol

φ12.5 or more (6.3V2200µF)

RTD — 6 V 222 M IE T — □

Series code Rated voltage symbol Rated capacitance symbol Capacitance tolerance symbol Casing symbol Taping symbol

- Soldering conditions are described on page 13.
- Land pattern size are described on page 11.
- The taping specifications are described on page 14.

Standard Ratings

Rated voltage (V)	Item	6.3				10				16				25				35						
		Case φD×L (mm)	Casing symbol	Impedance (Ω max.)	Rated ripple current (mA rms)	Case φD×L (mm)	Casing symbol	Impedance (Ω max.)	Rated ripple current (mA rms)	Case φD×L (mm)	Casing symbol	Impedance (Ω max.)	Rated ripple current (mA rms)	Case φD×L (mm)	Casing symbol	Impedance (Ω max.)	Rated ripple current (mA rms)	Case φD×L (mm)	Casing symbol	Impedance (Ω max.)	Rated ripple current (mA rms)			
100	—	—	—	—	—	—	—	—	—	—	—	—	—	—	—	—	—	—	—	—	—	—		
220	—	—	—	—	—	—	—	—	—	—	—	—	—	—	—	—	—	—	—	—	—	—		
330	—	—	—	—	8×10.5	GA5	0.16	600	8×10.5	GA5	0.16	600	8×10.5	GA5	0.16	600	8×10.5	GA5	0.16	600	8×10.5	GA5	0.16	600
470	8×10.5	GA5	0.16	600	8×10.5	GA5	0.16	600	8×10.5	GA5	0.16	600	10×10.5	HA5	0.090	850	12.5×13.5	IE	0.054	1160	12.5×13.5	IE	0.054	1160
680	8×10.5	GA5	0.16	600	10×10.5	HA5	0.090	850	10×10.5	HA5	0.090	850	12.5×13.5	IE	0.054	1160	12.5×13.5	IE	0.054	1160	12.5×13.5	IE	0.054	1160
1000	8×10.5	GA5	0.16	600	10×10.5	HA5	0.090	850	12.5×13.5	IE	0.054	1160	12.5×13.5	IE	0.054	1160	12.5×13.5	IE	0.054	1160	16×16.5	JH	0.044	1620
1500	10×10.5	HA5	0.090	850	12.5×13.5	IE	0.054	1160	12.5×13.5	IE	0.054	1160	16×16.5	JH	0.044	1620	18×16.5	KH	0.040	1840	18×16.5	KH	0.040	1840
2200	12.5×13.5	IE	0.054	1160	12.5×13.5	IE	0.060	1160	16×16.5	JH	0.044	1620	16×16.5	JM	0.038	1920	18×16.5	KH	0.040	1840	18×21.5	KM	0.036	2080
3300	16×16.5	JH	0.044	1620	16×16.5	JH	0.044	1620	16×21.5	JM	0.038	1920	18×16.5	KH	0.040	1840	18×21.5	KM	0.036	2080	—	—	—	—
4700	18×16.5	KH	0.040	1840	18×16.5	KM	0.038	2080	18×21.5	KM	0.036	2080	—	—	—	—	—	—	—	—	—	—	—	
6800	18×16.5	KH	0.040	1840	—	—	—	—	—	—	—	—	—	—	—	—	—	—	—	—	—	—	—	
8200	18×21.5	KM	0.036	2080	—	—	—	—	—	—	—	—	—	—	—	—	—	—	—	—	—	—	—	

Rated voltage (V)	Item	50				63				80				100			
		Case φD×L (mm)	Casing symbol	Impedance (Ω max.)	Rated ripple current (mA rms)	Case φD×L (mm)	Casing symbol	Impedance (Ω max.)	Rated ripple current (mA rms)	Case φD×L (mm)	Casing symbol	Impedance (Ω max.)	Rated ripple current (mA rms)	Case φD×L (mm)	Casing symbol	Impedance (Ω max.)	Rated ripple current (mA rms)
100	8×10.5	GA5	0.32	350	12.5×13.5	IE	0.16	600	12.5×13.5	IE	0.18	550	16×16.5	JH	0.17	700	
220	10×10.5	HA5	0.18	700	12.5×13.5	IE	0.16	600	16×16.5	JH	0.16	720	18×16.5	KH	0.15	800	
330	12.5×13.5	IE	0.12	900	16×16.5	JH	0.14	800	18×16.5	KH	0.13	830	18×21.5	KM	0.13	940	
470	16×16.5	JH	0.080	1000	18×16.5	KH	0.12	900	18×21.5	KM	0.11	1000	—	—	—	—	
680	16×16.5	JH	0.080	1000	18×21.5	KM	0.10	1050	—	—	—	—	—	—	—	—	
1000	18×16.5	KH	0.076	1100	—	—	—	—	—	—	—	—	—	—	—	—	

(Note) Rated ripple current : 105°C, 100kHz, Impedance : 20°C, 100kHz

NOTE

Design, Specifications are subject to change without notice. Ask factory for technical specifications before purchase and/or use.

Chip Type 125°C Use, Low ESR, Long Life Capacitors GREEN CAP SMD 125°C
2000hours Anti-cleaning solvent

- Compatible with surface mounting.
- For Vibration resistance.
- Supplied with carrier taping.
- Guarantees 2000 hours at 125°C.
(φ12.5 or more : 5000h)

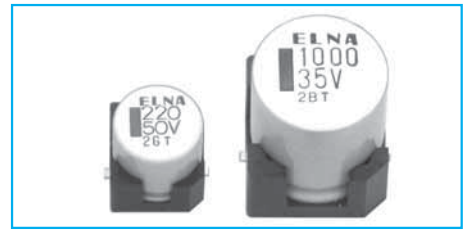
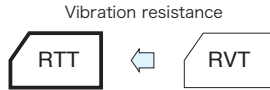

Marking color : Black print

Specifications

Item	Performance									
Category temperature range (°C)	-40 to +125									
Tolerance at rated capacitance (%)	±20 (20°C,120Hz)									
Leakage current (μA)	Less than 0.01CV or 3 whichever is larger (after 2 minutes) C : Rated capacitance (μF) , V : Rated voltage (V) (20°C)									
Tangent of loss angle (tanδ)	Rated voltage (V)	10	16	25	35	50	63	80	100	
	Tangent of loss angle	0.24	0.20	0.16	0.14	0.14	0.12	0.12	0.10	
0.02 is added to every 1000μF increase over 1000μF (20°C,120Hz)										
Characteristics at high and low temperature	Impedance ratio (max.)	Rated voltage (V)	10	16	25	35	50	63	80	100
		Z-25°C/Z+20°C	3	2	2	2	2	2	2	2
		Z-40°C/Z+20°C	4	3	3	3	3	3	3	3
(120Hz)										
Endurance (125°C)	Test time	2000 hours (φ12.5 or more : 5000h)								
	Leakage current	The initial specified value or less								
	Percentage of capacitance change	Within -30% to +30% of initial value								
	Tangent of loss angle	300% or less of the initial specified value								
Shelf life (125°C)	Test time : 1000 hours ; other items are the same as those for the endurance. Voltage application treatment : According to JIS C5101-1									
Applicable standards	JIS C5101-1 1998, -18 1999 (IEC 60384-1 1992, -18 1993)									

Outline Drawing

Unit : mm

φD	L	A	B	C	W	P	M	Casing symbol
8	10.0±0.5	8.4	8.4	3.0	0.7 to 1.1	3.1	0.4±0.2	G10
10	10.0±0.5	10.4	10.4	3.3	0.7 to 1.1	4.7	0.4±0.2	H10
12.5	13.5±0.5	13	13	4.9	1.0 to 1.4	4.6	0.7±0.3	IE
12.5	16.0±0.5	13	13	4.9	1.0 to 1.4	4.6	0.7±0.3	IH
16	16.5±0.5	17	17	5.6	1.0 to 1.4	7.2	0.7±0.3	JH
16	21.5±0.5	17	17	5.6	1.0 to 1.4	7.2	0.7±0.3	JM
18	16.5±0.5	19	19	6.6	1.0 to 1.4	7.2	0.7±0.3	KH
18	21.5±0.5	19	19	6.6	1.0 to 1.4	7.2	0.7±0.3	KM

() : Reference size
 □ : Dummy terminal

Coefficient of Frequency for Rated Ripple Current

Frequency (Hz)	120	1k	10k	100k
Rated voltage (V)				
10 to 100	0.77	0.88	0.96	1.00

Part numbering system

φ8, φ10 (35V100μF)

RTT — 35 V 101 M H10 SU — □

Series code Rated voltage symbol Rated capacitance symbol Capacitance tolerance symbol Casing symbol Taping symbol

φ12.5 or more (35V1000μF)

RTT — 35 V 102 M KM T — □

Series code Rated voltage symbol Rated capacitance symbol Capacitance tolerance symbol Casing symbol Taping symbol

- Soldering conditions are described on page 13.
- Land pattern size are described on page 11.
- The taping specifications are described on page 14.

Standard Ratings

Rated voltage (V)	Item	10						16						25						35						50					
		Case		ESR (Ω max.)		Rated ripple current		Case		ESR (Ω max.)		Rated ripple current		Case		ESR (Ω max.)		Rated ripple current		Case		ESR (Ω max.)		Rated ripple current		Case		ESR (Ω max.)		Rated ripple current	
		φDxL (mm)	20°C	-40°C	(mA)	(mA)	(mA)	φDxL (mm)	20°C	-40°C	(mA)	(mA)	(mA)	φDxL (mm)	20°C	-40°C	(mA)	(mA)	(mA)	φDxL (mm)	20°C	-40°C	(mA)	(mA)	(mA)	φDxL (mm)	20°C	-40°C	(mA)	(mA)	(mA)
100	—	—						—						—						—											
		—						—						—						—											
220	—	—						8x10 0.25 2.5 340						8x10 0.25 2.5 340						8x10 0.25 2.5 340						10x10 0.15 1.5 500					
		—						10x10 0.15 1.5 500						10x10 0.15 1.5 500						10x10 0.15 1.5 500											
330	—	8x10 0.25 2.5 340						10x10 0.15 1.5 500						10x10 0.15 1.5 500						12.5x13.5 0.086 1.29 750						16x16.5 0.12 1.8 850					
		10x10 0.15 1.5 500						12.5x13.5 0.086 1.29 750						12.5x13.5 0.086 1.29 750						16x16.5 0.060 0.90 1000											
470	—	10x10 0.15 1.5 500						12.5x13.5 0.086 1.29 750						12.5x13.5 0.086 1.29 750						16x16.5 0.060 0.90 1000						18x16.5 0.10 1.5 920					
		—						16x16.5 0.060 0.90 1000						16x16.5 0.060 0.90 1000						18x16.5 0.050 0.75 1200											
680	—	12.5x13.5 0.086 1.29 750						12.5x13.5 0.086 1.29 750						16x16.5 0.060 0.90 1000						18x16.5 0.050 0.75 1200						—					
		—						16x16.5 0.060 0.90 1000						18x16.5 0.050 0.75 1200						18x16.5 0.050 0.75 1200											
1000	—	12.5x13.5 0.086 1.29 750						18x16.5 0.050 0.75 1200						18x21.5 0.042 0.63 1550						18x21.5 0.042 0.63 1550						—					
		—						16x16.5 0.06 0.90 1000						—						—											
2200	—	16x16.5 0.06 0.90 1000						18x16.5 0.050 0.75 1200						—						—						—					
		—						18x16.5 0.05 0.75 1200						—						—											
3300	—	18x16.5 0.05 0.75 1200						18x21.5 0.042 0.63 1550						—						—						—					
		—						—						—						—											
4700	—	18x21.5 0.042 0.63 1550						—						—						—						—					
		—						—						—						—											
Rated voltage (V)	Item	63						80						100																	
		Case		ESR (Ω max.)		Rated ripple current		Case		ESR (Ω max.)		Rated ripple current		Case		ESR (Ω max.)		Rated ripple current													
		φDxL (mm)	20°C	-40°C	(mA)	(mA)	(mA)	φDxL (mm)	20°C	-40°C	(mA)	(mA)	(mA)	φDxL (mm)	20°C	-40°C	(mA)	(mA)	(mA)												
		—	—	—	—	—	—	—	—	—	—	—	—	—	—	—	—	—	—												
		47	—	—	—	—	—	—	—	—	—	—	—	—	—	—	—	—	—												
100	12.5x13.5	0.25	3.75	400	16x16.5	0.24	3.6	480	16x16.5	0.24	3.6	480	12.5x13.5	0.32	4.8	300															
220	16x16.5	0.22	3.3	500	16x21.5	0.18	2.7	600	16x16.5	0.24	3.6	480	16x16.5	0.16	2.4	700															
330	16x16.5	0.22	3.3	500	18x21.5	0.12	1.8	1000	—	—	—	—	—	—	—	—															
470	16x21.5	0.16	2.4	650	—	—	—	—	—	—	—	—	—	—	—	—															

(Note) Rated ripple current : 105°C , 100kHz, ESR : 100kHz

NOTE

Design, Specifications are subject to change without notice.
 Ask factory for technical specifications before purchase and/or use.

Horizontal type, 125°C Use, High-temperature Capacitors

SMD

Vibration Resistance

125°C 1000hours

Anti-cleaning solvent

- 125°C high temperature surface mount.
- Highly resistant to vibration.
- Available in horizontal configurations only.
- Carrier taping supplied.
- Guarantees 1000 hours at 125°C.

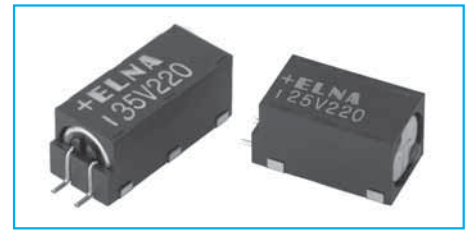
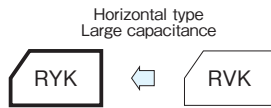

Marking color : White print on a black case

Specifications

Item	Performance																							
Category temperature range (°C)	-40 to +125																							
Tolerance at rated capacitance (%)	±20 (20°C, 120Hz)																							
Leakage current (µA)	Less than 0.02CV (after 2 minutes) C : Rated capacitance (µF) ; V : Rated voltage (V) (20°C)																							
Tangent of loss angle (tanδ)	<table border="1"> <tr> <th>Rated voltage (V)</th> <td>6.3</td> <td>10</td> <td>16</td> <td>25</td> <td>35</td> <td>50</td> <td>63</td> </tr> <tr> <th>tanδ (max.)</th> <td>0.3</td> <td>0.28</td> <td>0.26</td> <td>0.24</td> <td>0.20</td> <td>0.19</td> <td>0.18</td> </tr> </table>	Rated voltage (V)	6.3	10	16	25	35	50	63	tanδ (max.)	0.3	0.28	0.26	0.24	0.20	0.19	0.18							
	Rated voltage (V)	6.3	10	16	25	35	50	63																
tanδ (max.)	0.3	0.28	0.26	0.24	0.20	0.19	0.18																	
	(20°C, 120Hz)																							
Characteristics at high and low temperature	<table border="1"> <tr> <th>Rated voltage (V)</th> <td>6.3</td> <td>10</td> <td>16</td> <td>25</td> <td>35</td> <td>50</td> <td>63</td> </tr> <tr> <th rowspan="2">Impedance ratio (max.)</th> <td>Z-25°C/Z+20°C</td> <td>3</td> <td>3</td> <td>3</td> <td>3</td> <td>3</td> <td>3</td> </tr> <tr> <td>Z-40°C/Z+20°C</td> <td>5</td> <td>5</td> <td>5</td> <td>5</td> <td>5</td> <td>5</td> </tr> </table>	Rated voltage (V)	6.3	10	16	25	35	50	63	Impedance ratio (max.)	Z-25°C/Z+20°C	3	3	3	3	3	3	Z-40°C/Z+20°C	5	5	5	5	5	5
	Rated voltage (V)	6.3	10	16	25	35	50	63																
Impedance ratio (max.)	Z-25°C/Z+20°C	3	3	3	3	3	3																	
	Z-40°C/Z+20°C	5	5	5	5	5	5																	
	(120Hz)																							
Endurance (125°C) (Applied ripple current)	Test time	1000 hours																						
	Percentage of capacitance change	Within ±30% of initial value																						
	Tangent of the loss angle	300% or less of the initial specified value																						
	Leakage current	The initial specified value or less																						
Shelf life (125°C)	Test time	1000 hours																						
	Percentage of capacitance change	Within ±20% of initial value																						
	Tangent of the loss angle	200% or less of the initial specified value																						
	Leakage current	The initial specified value or less																						
	Pretreatment performed																							
Applicable standards	JIS C5101-1 1998, -18 1999 (IEC 60384-1 1992, -18 1993)																							

Outline Drawing

Unit : mm

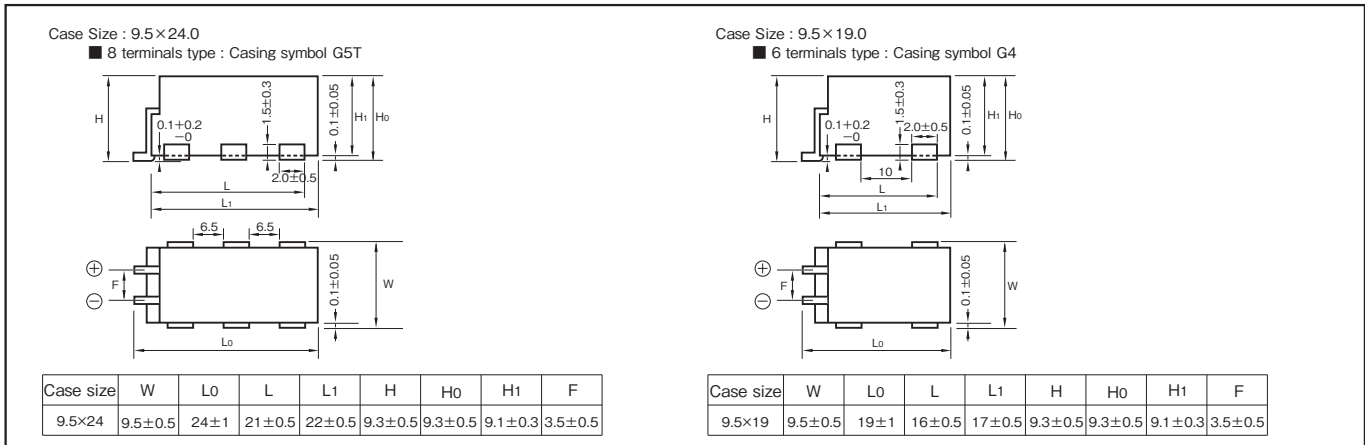

• Soldering conditions are described on page 11. • Land pattern size are described on page 12. • The taping specifications are described on page 13.

Part numbering system (example: 10V560µF)

RYK	—	10	V	561	M	G5T	T	—	FL
Series code		Rated voltage symbol		Rated capacitance symbol	Capacitance tolerance symbol	Casing symbol			Tray polarity symbol

Coefficient of Frequency for Rated Ripple Current

Frequency (Hz)	120	1k	10k	100k
Rated voltage (V)				
10 to 63	0.77	0.88	0.96	1

Standard Ratings

Rated capacitance (µF)	Item	6.3			10			16			25			35			50			63		
		Case W×L (mm)	Impedance (Ω)	Rated ripple current (mA)	Case W×L (mm)	Impedance (Ω)	Rated ripple current (mA)	Case W×L (mm)	Impedance (Ω)	Rated ripple current (mA)	Case W×L (mm)	Impedance (Ω)	Rated ripple current (mA)	Case W×L (mm)	Impedance (Ω)	Rated ripple current (mA)	Case W×L (mm)	Impedance (Ω)	Rated ripple current (mA)			
56	—	—	—	—	—	—	—	—	—	—	—	—	—	—	—	—	—	—	—	—		
82	—	—	—	—	—	—	—	—	—	—	—	—	—	—	—	—	9.5×19.0	0.49	210	9.5×24.0	0.37	272
100	—	—	—	—	—	—	—	—	—	—	—	—	9.5×19.0	0.40	232	9.5×24.0	0.35	279	—	—	—	
220	—	—	—	—	—	—	—	—	—	—	—	—	9.5×19.0	0.40	232	9.5×24.0	0.30	302	—	—	—	
270	—	—	—	—	—	—	—	—	—	—	—	—	9.5×19.0	0.40	232	9.5×24.0	0.30	302	—	—	—	
470	—	—	—	—	—	—	—	—	—	—	—	—	9.5×19.0	0.40	232	9.5×24.0	0.30	302	—	—	—	
560	9.5×19.0	0.40	232	9.5×24.0	0.30	302	—	—	—	—	—	—	—	—	—	—	—	—	—	—		
820	9.5×24.0	0.30	302	—	—	—	—	—	—	—	—	—	—	—	—	—	—	—	—	—		

(Note) Rated ripple current : 125°C, 100kHz ; Impedance : 20°C, 100kHz

NOTE

Design, Specifications are subject to change without notice. Ask factory for technical specifications before purchase and/or use.

Miniature Aluminum Electrolytic Capacitors

5mm L Standard Capacitors

GREEN CAP

• Diameters from $\phi 3$ to $\phi 8$ mm and a height of 5mm.

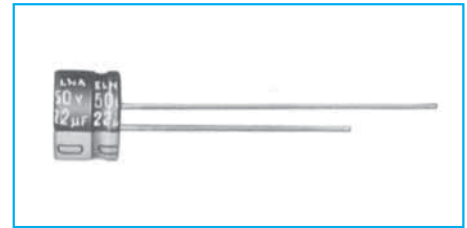
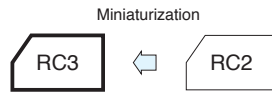

Marking color : White print on a blue sleeve ($\phi 3$: black sleeve)

Specifications

Item	Performance								
Category temperature range (°C)	-40 to +85								
Tolerance at rated capacitance (%)	± 20 (20°C, 120Hz)								
Leakage current (μA)	Less than 0.01CV or 3 whichever is larger (after 2 minutes) C : Rated capacitance (μF); V : Rated voltage (V) (20°C)								
Tangent of loss angle (tan δ)	Rated voltage (V)								
		4	6.3	10	16	25	35	50	
tan δ (max.)	$\phi 3$ to $\phi 6.3$	0.35	0.24	0.20	0.16	0.14	0.12	0.10	
	$\phi 8$	0.39	0.28	0.24	0.16	0.14	0.12	0.10	
Characteristics at high and low temperature	Rated voltage (V)								
	Impedance ratio (max.)	Z-25°C/Z+20°C	6	4	3	2	2	2	2
		Z-40°C/Z+20°C	16	10	8	6	4	4	4
								(120Hz)	
Endurance (85°C) (Applied ripple current)	Test time								
	1000 hours								
	Leakage current								
	The initial specified value or less								
Percentage of capacitance change									
Within $\pm 20\%$ of initial value									
Tangent of the loss angle									
200% or less of the initial specified value									
Shelf life (85°C)	Test time : 1000 hours ; other items are the same as those for the endurance. Voltage application treatment : According to JIS C5101-1								
Applicable standards	JIS C5101-1, -4 1998 (IEC 60384-1 1992, -4 1985)								

Outline Drawing

Unit : mm

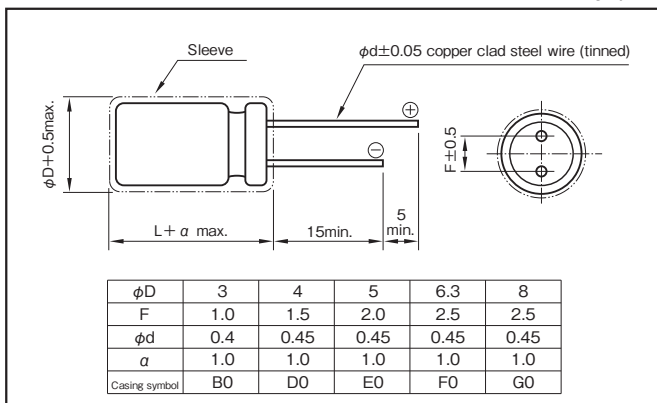

Coefficient of Frequency for Rated Ripple Current

Rated voltage (V)	Frequency (Hz)			
	50 · 60	120	1k	10k · 100k
4 to 16	0.8	1	1.1	1.2
25 to 35	0.8	1	1.5	1.7
50	0.8	1	1.6	1.9

Part numbering system (example : 6.3V100 μF)

RC3	—	6	V	101	M	F0	#	☒	—	☐
Series code		Rated voltage symbol		Rated capacitance symbol	Capacitance tolerance symbol	Casing symbol	Additional symbol			Taping (Forming)

*Should add "2", when size is $\phi 3 \times 5L$.

Standard Ratings

Rated capacitance (μF)	4		6.3		10		16		25		35		50	
	Case	Rated ripple current (mArms)	Case	Rated ripple current (mArms)	Case	Rated ripple current (mArms)	Case	Rated ripple current (mArms)	Case	Rated ripple current (mArms)	Case	Rated ripple current (mArms)	Case	Rated ripple current (mArms)
0.1	—	—	—	—	—	—	—	—	—	—	—	—	3×5	3
0.22	—	—	—	—	—	—	—	—	—	—	—	—	· 4×5	5 (4)
0.33	—	—	—	—	—	—	—	—	—	—	—	—	· 4×5	6 (5)
0.47	—	—	—	—	—	—	—	—	—	—	—	—	· 4×5	7 (6)
1	—	—	—	—	—	—	—	—	—	—	—	—	· 4×5	10 (8)
2.2	—	—	—	—	—	—	—	—	—	—	· 4×5	14 (11)	4×5	15
3.3	—	—	—	—	—	—	—	—	· 4×5	15 (13)	4×5	17	4×5	18
4.7	—	—	—	—	—	—	· 4×5	17 (14)	4×5	18	4×5	20	5×5	25
10	—	—	· 4×5	20 (17)	4×5	22	4×5	25	5×5	30	5×5	30	6.3×5	40
22	· 4×5	25 (21)	4×5	30	5×5	35	5×5	40	6.3×5	50	6.3×5	55	8×5	75
33	4×5	30	5×5	40	5×5	45	6.3×5	60	6.3×5	65	8×5	80	8×5	90
47	4×5	35	5×5	50	6.3×5	65	6.3×5	70	8×5	95	8×5	100	—	—
100	5×5	60	6.3×5	85	6.3×5	95	8×5	125	8×5	135	—	—	—	—
220	6.3×5	105	8×5	145	8×5	155	—	—	—	—	—	—	—	—
330	8×5	150	—	175	—	—	—	—	—	—	—	—	—	—
470	8×5	180	—	—	—	—	—	—	—	—	—	—	—	—

(Note) Rated ripple current : 85°C, 120Hz ; The types of capacitor marked with a black circle are manufactured in the $\phi 3 \times 5$ size also ; the figures in the parentheses are applicable to capacitors with $\phi 3$.

NOTE

Design, Specifications are subject to change without notice. Ask factory for technical specifications before purchase and/or use.

5mm L, 105°C Use Capacitors

GREEN CAP 105°C 1000hours Anti-cleaning solvent

- Diameters from $\phi 4$ to $\phi 6.3$ mm and a height of 5mm.
- Guarantees 1000 hours at 105°C.

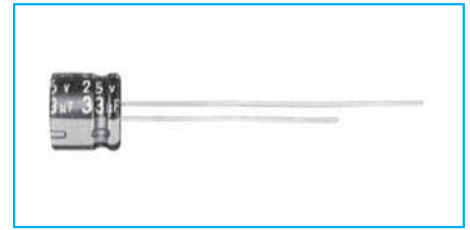
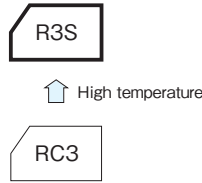

Marking color : White print on a black sleeve

Specifications

Item	Performance							
Category temperature range (°C)	-55 to +105							
Tolerance at rated capacitance (%)	±20 (20°C, 120Hz)							
Leakage current (µA)	Less than 0.01CV or 3 whichever is larger (after 2 minutes) C : Rated capacitance (µF); V : Rated voltage (V) (20°C)							
Tangent of loss angle (tanδ)	Rated voltage (V)	6.3	10	16	25	35	50	
	tanδ (max.)	0.28	0.24	0.20	0.14	0.12	0.10	(20°C, 120Hz)
Characteristics at high and low temperature	Rated voltage (V)	6.3	10	16	25	35	50	
	Impedance ratio (max.)	Z-25°C/Z+20°C	3	3	2	2	2	2
Endurance (105°C) (Applied ripple current)	Test time	1000 hours						
	Leakage current	The initial specified value or less						
	Percentage of capacitance change	Within ±20% of initial value						
	Tangent of the loss angle	200% or less of the initial specified value						
Shelf life (105°C)	Test time : 1000 hours ; other items are the same as those for the endurance. Voltage application treatment : According to JIS C5101-1							
Applicable standards	JIS C5101-1, -4 1998 (IEC 60384-1 1992, -4 1985)							

Outline Drawing

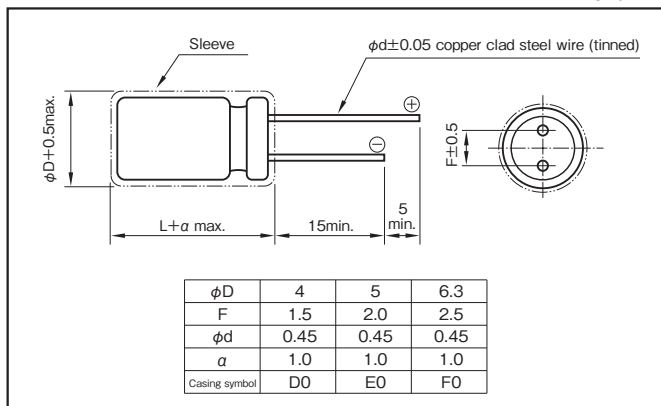

Coefficient of Frequency for Rated Ripple Current

Rated voltage (V)	Frequency (Hz)			
	50 · 60	120	1k	10k · 100k
6.3 to 16	0.64	0.80	0.92	1
25 to 35	0.57	0.71	0.89	1
50	0.53	0.67	0.90	1

Part numbering system (example : 16V47µF)

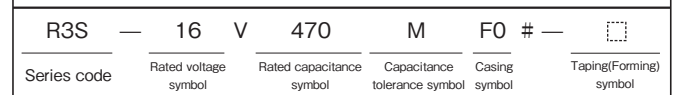

Standard Ratings

Rated voltage (V)	6.3		10		16		25		35		50	
	Case	Rated ripple current (mArms)	Case	Rated ripple current (mArms)	Case	Rated ripple current (mArms)	Case	Rated ripple current (mArms)	Case	Rated ripple current (mArms)	Case	Rated ripple current (mArms)
0.22	—	—	—	—	—	—	—	—	—	—	4×5	5
0.33	—	—	—	—	—	—	—	—	—	—	4×5	6
0.47	—	—	—	—	—	—	—	—	—	—	4×5	8
1	—	—	—	—	—	—	—	—	—	—	4×5	11
2.2	—	—	—	—	—	—	—	—	—	—	4×5	17
3.3	—	—	—	—	—	—	—	—	4×5	17	4×5	20
4.7	—	—	—	—	4×5	15	4×5	18	4×5	20	5×5	27
10	—	—	4×5	20	4×5	23	5×5	31	5×5	34	6.3×5	45
22	4×5	26	5×5	34	5×5	38	6.3×5	53	6.3×5	57	—	—
33	5×5	33	5×5	43	6.3×5	56	6.3×5	66	—	—	—	—
47	5×5	45	6.3×5	58	6.3×5	65	—	—	—	—	—	—
100	6.3×5	78	—	—	—	—	—	—	—	—	—	—

(Note) Rated ripple current : 105°C, 100kHz.

NOTE

Design, Specifications are subject to change without notice. Ask factory for technical specifications before purchase and/or use.

5mm L Bipolar Capacitors GREEN CAP

• Diameters from $\phi 4$ to $\phi 6.3$ mm and a height of 5mm.

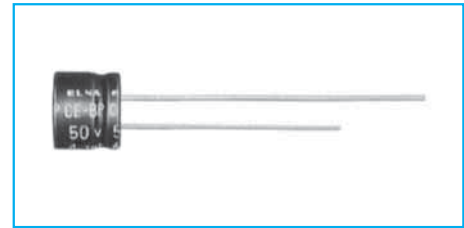
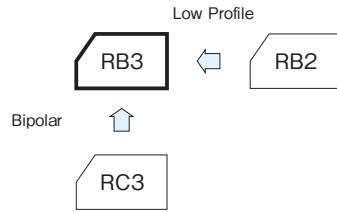

Marking color : White print on a blue sleeve

Specifications

Item	Performance							
Category temperature range (°C)	-40 to +85							
Tolerance at rated capacitance (%)	±20 (20°C, 120Hz)							
Leakage current (μA)	Less than 0.03CV +3 (after 5 minutes) C : Rated capacitance (μF); V : Rated voltage (V) (20°C)							
Tangent of loss angle (tanδ)	Rated voltage (V)		6.3	10	16	25	35	50
	tanδ (max.)	$\phi 4$	0.35	0.30	0.25	0.20	0.20	0.20
$\phi 5, 6.3$		0.30	0.25	0.20	0.15	0.15	0.15	
Endurance (85°C) (Applied ripple current)	Test time	1000 hours (with the polarity inverted every 250 hours)						
	Leakage current	The initial specified value or less						
	Percentage of capacitance change	Within ±20% of initial value						
	Tangent of the loss angle	200% or less of the initial specified value						
Applicable standards	JIS C5101-1, -4 1998 (IEC 60384-1 1992, -4 1985)							

Outline Drawing

Unit : mm

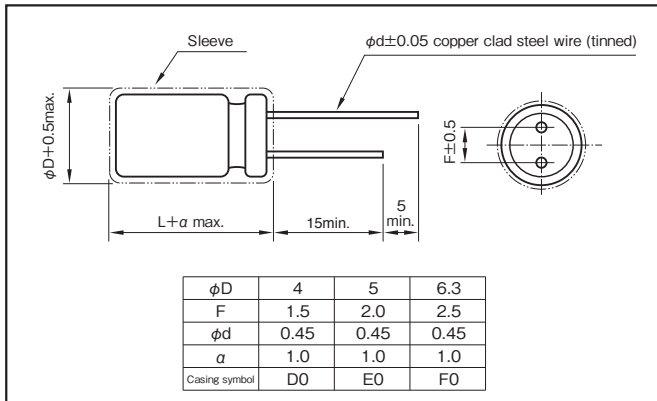

Coefficient of Frequency for Rated Ripple Current

Rated voltage (V)	Frequency (Hz)			
	50 · 60	120	1k	10k · 100k
6.3 to 16	0.8	1	1.1	1.2
25 to 35	0.8	1	1.5	1.7
50	0.8	1	1.6	1.9

Part numbering system (example : 10V47μF)

RB3	—	10	V	470	M	F0	#	—	□
Series code		Rated voltage symbol		Rated capacitance symbol	Capacitance tolerance symbol	Casing symbol			Taping(Forming) symbol

Standard Ratings

Rated capacitance (μF)	Rated voltage (V) 6.3		10		16		25		35		50	
	Case	Rated ripple current	Case	Rated ripple current	Case	Rated ripple current	Case	Rated ripple current	Case	Rated ripple current	Case	Rated ripple current
	$\phi D \times L$ (mm)	(mArms)	$\phi D \times L$ (mm)	(mArms)	$\phi D \times L$ (mm)	(mArms)	$\phi D \times L$ (mm)	(mArms)	$\phi D \times L$ (mm)	(mArms)	$\phi D \times L$ (mm)	(mArms)
0.22	—	—	—	—	—	—	—	—	—	—	4×5	3
0.33	—	—	—	—	—	—	—	—	—	—	4×5	4
0.47	—	—	—	—	—	—	—	—	—	—	4×5	5
1	—	—	—	—	—	—	—	—	—	—	4×5	7
2.2	—	—	—	—	—	—	—	—	4×5	11	5×5	14
3.3	—	—	—	—	—	—	4×5	13	5×5	17	6.3×5	20
4.7	—	—	—	—	4×5	14	5×5	21	6.3×5	24	6.3×5	24
10	—	—	4×5	18	5×5	26	6.3×5	35	6.3×5	35	—	—
22	5×5	31	6.3×5	40	6.3×5	45	—	—	—	—	—	—
33	6.3×5	45	6.3×5	49	—	—	—	—	—	—	—	—
47	6.3×5	54	6.3×5	59	—	—	—	—	—	—	—	—

(Note) Rated ripple current : 85°C, 120Hz.

NOTE

Design, Specifications are subject to change without notice. Ask factory for technical specifications before purchase and/or use.

7mm L, Standard Capacitors

GREEN CAP Anti-cleaning solvent

- Conventional RC2 further downsized, diameters from $\phi 4$ to $\phi 8$ mm.
- Guarantees 1000 hours at 85°C.

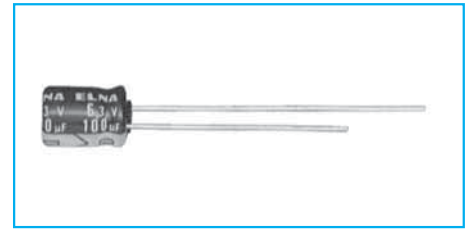
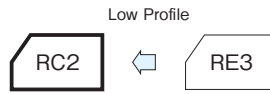

Marking color : White print on a blue sleeve

Specifications

Item	Performance									
Category temperature range (°C)	-40 to +85									
Tolerance at rated capacitance (%)	±20 (20°C,120Hz)									
Leakage current (µA)	Less than 0.01CV or 3 whichever is larger (after 2 minutes) C : Rated capacitance (µF); V : Rated voltage (V) (20°C)									
Tangent of loss angle (tanδ)	Rated voltage (V)	4	6.3	10	16	25	35	50	63	100
	tanδ (max.)	0.35	0.24	0.20	0.16	0.14	0.12	0.10	0.08	0.08
Characteristics at high and low temperature	Rated voltage (V)	4	6.3	10	16	25	35	50	63	100
	Impedance ratio (max.)	Z-25°C/Z+20°C	6	4	3	2	2	2	2	2
		Z-40°C/Z+20°C	16	10	8	6	4	4	4	4
Endurance (85°C) (Applied ripple current)	Test time	1000 hours								
	Leakage current	The initial specified value or less								
	Percentage of capacitance change	Within ±20% of initial value								
	Tangent of the loss angle	200% or less of the initial specified value								
Shelf life (85°C)	Test time : 1000 hours ; other items are the same as those for the endurance. Voltage application treatment : According to JIS C5101-1									
Applicable standards	JIS C5101-1, -4 1998 (IEC 60384-1 1992, -4 1985)									

Outline Drawing

Unit : mm

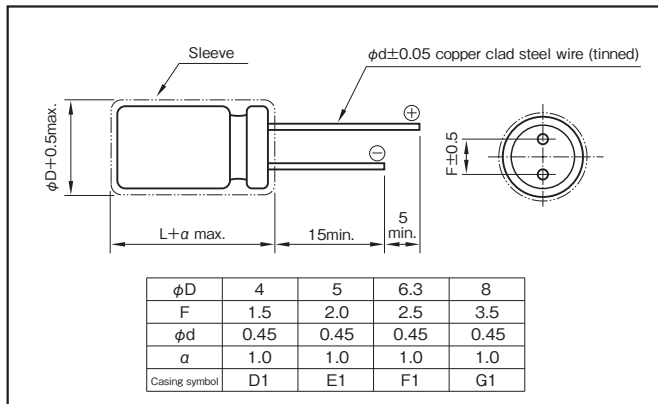

Coefficient of Frequency for Rated Ripple Current

Rated voltage (V)	Frequency (Hz)			
	50 · 60	120	1k	10k · 100k
4 to 16	0.8	1	1.1	1.2
25 to 35	0.8	1	1.5	1.7
50 to 100	0.8	1	1.6	1.9

Part numbering system (example : 10V220µF)



Standard Ratings

Rated voltage (V)	4		6.3		10		16		25		35		50		63		100	
	Case	Rated ripple current	Case	Rated ripple current	Case	Rated ripple current	Case	Rated ripple current	Case	Rated ripple current	Case	Rated ripple current	Case	Rated ripple current	Case	Rated ripple current	Case	Rated ripple current
Rated capacitance (µF)	φD×L (mm)	(mArms)	φD×L (mm)	(mArms)	φD×L (mm)	(mArms)	φD×L (mm)	(mArms)	φD×L (mm)	(mArms)	φD×L (mm)	(mArms)	φD×L (mm)	(mArms)	φD×L (mm)	(mArms)	φD×L (mm)	(mArms)
0.33	—	—	—	—	—	—	—	—	—	—	—	—	—	—	—	—	—	—
0.47	—	—	—	—	—	—	—	—	—	—	—	—	4×7	8	4×7	8	—	—
1	—	—	—	—	—	—	—	—	—	—	—	—	4×7	10	4×7	10	4×7	12
2.2	—	—	—	—	—	—	—	—	—	—	—	—	4×7	15	4×7	15	5×7	20
3.3	—	—	—	—	—	—	—	—	4×7	15	4×7	15	4×7	20	4×7	23	6.3×7	30
4.7	—	—	—	—	—	—	—	—	4×7	20	4×7	20	4×7	24	5×7	30	6.3×7	35
10	—	—	—	—	—	—	4×7	25	4×7	30	4×7	30	5×7	40	6.3×7	50	—	—
22	—	—	4×7	35	4×7	35	4×7	40	5×7	50	5×7	55	6.3×7	70	—	—	—	—
33	4×7	35	4×7	40	4×7	45	5×7	55	6.3×7	70	6.3×7	75	8×7	100	—	—	—	—
47	4×7	40	4×7	50	5×7	60	5×7	70	6.3×7	85	8×7	110	—	—	—	—	—	—
100	5×7	70	5×7	80	6.3×7	105	6.3×7	120	8×7	145	—	—	—	—	—	—	—	—
220	6.3×7	120	6.3×7	140	8×7	185	8×7	205	—	—	—	—	—	—	—	—	—	—
330	8×7	170	8×7	205	—	—	—	—	—	—	—	—	—	—	—	—	—	—

(Note) Rated ripple current : 85°C, 120Hz.

NOTE

Design, Specifications are subject to change without notice.
Ask factory for technical specifications before purchase and/or use.

7mm L, 105°C Use Capacitors

GREEN CAP 105°C 1000hours Anti-cleaning solvent

- Diameters from $\phi 4$ to $\phi 6.3$ mm and a height of 7mm.
- Guarantees 1000 hours at 105°C.



High temperature

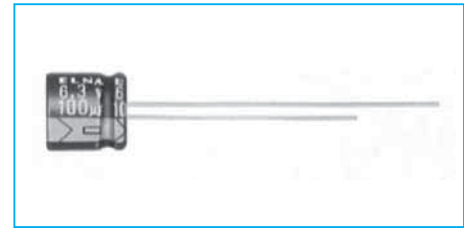

Marking color : White print on a black sleeve

Specifications

Item	Performance	
Category temperature range (°C)	-55 to +105	
Tolerance at rated capacitance (%)	±20 (20°C, 120Hz)	
Leakage current (μA)	Less than 0.01CV or 3 whichever is larger (after 2 minutes) C : Rated capacitance (μF); V : Rated voltage (V) (20°C)	
Tangent of loss angle (tanδ)	Rated voltage (V)	6.3 10 16 25 35 50
	tanδ (max.)	0.22 0.19 0.16 0.14 0.12 0.10
		(20°C, 120Hz)
Characteristics at high and low temperature	Rated voltage (V)	6.3 10 16 25 35 50
	Impedance ratio (max.)	Z-25°C/Z+20°C 3 3 2 2 2 2
		Z-40°C/Z+20°C 8 5 4 3 3 3
		(120Hz)
Endurance (105°C) (Applied ripple current)	Test time	1000 hours
	Leakage current	The initial specified value or less
	Percentage of capacitance change	Within ±20% of initial value
	Tangent of the loss angle	200% or less of the initial specified value
Shelf life (105°C)	Test time : 1000 hours ; other items are the same as those for the endurance. Voltage application treatment : According to JIS C5101-1	
Applicable standards	JIS C5101-1, -4 1998 (IEC 60384-1 1992, -4 1985)	

Outline Drawing

Unit : mm

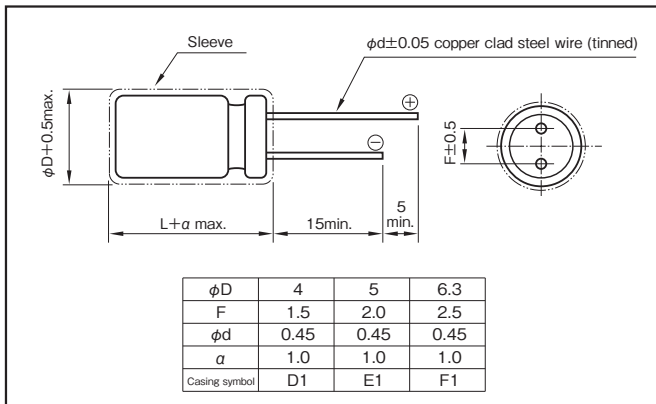

Coefficient of Frequency for Rated Ripple Current

Rated voltage (V)	Frequency (Hz)			
	50 · 60	120	1k	10k · 100k
6.3 to 16	0.68	0.72	0.92	1
25 to 35	0.48	0.63	0.80	1
50	0.45	0.50	0.70	1

Part numbering system (example : 25V33μF)

R2S	—	25	V	330	M	F1	#	—	
Series code		Rated voltage symbol		Rated capacitance symbol	Capacitance tolerance symbol	Casing symbol			Taping(Forming) symbol

Standard Ratings

Rated voltage (V)	6.3		10		16		25		35		50	
	Case	Rated ripple current (mA)	Case	Rated ripple current (mA)	Case	Rated ripple current (mA)	Case	Rated ripple current (mA)	Case	Rated ripple current (mA)	Case	Rated ripple current (mA)
0.33	—	—	—	—	—	—	—	—	—	—	4×7	10
0.47	—	—	—	—	—	—	—	—	—	—	4×7	12
1	—	—	—	—	—	—	—	—	—	—	4×7	16
2.2	—	—	—	—	—	—	—	—	—	—	4×7	25
3.3	—	—	—	—	—	—	4×7	21	4×7	23	4×7	28
4.7	—	—	—	—	—	—	4×7	25	4×7	25	5×7	48
10	—	—	—	—	4×7	39	5×7	47	5×7	48	6.3×7	75
22	4×7	42	4×7	49	5×7	54	6.3×7	87	6.3×7	90	—	—
33	5×7	53	5×7	60	6.3×7	83	6.3×7	90	—	—	—	—
47	5×7	64	6.3×7	95	6.3×7	95	—	—	—	—	—	—
100	6.3×7	96	—	—	—	—	—	—	—	—	—	—

(Note) Rated ripple current : 105°C, 100kHz.

NOTE

Design, Specifications are subject to change without notice. Ask factory for technical specifications before purchase and/or use.

7mm L Bipolar Capacitors

GREEN CAP

Anti-cleaning solvent

• Diameters from $\phi 4$ to $\phi 6.3$ mm and a height of 7mm.

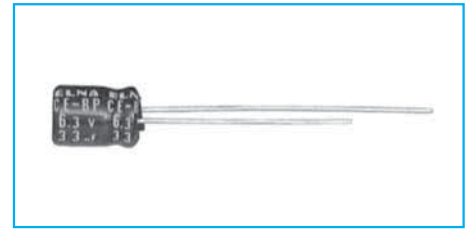
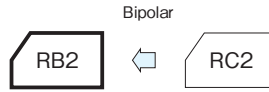

Marking color : White print on a blue sleeve

Specifications

Item	Performance						
Category temperature range (°C)	-40 to +85						
Tolerance at rated capacitance (%)	±20 (20°C, 120Hz)						
Leakage current (μA)	Less than 0.03CV + 3 (after 5 minutes) C : Rated capacitance (μF) ; V : Rated voltage (V) (20°C)						
Tangent of loss angle (tanδ)	Rated voltage (V)	6.3	10	16	25	35	50
	tanδ (max.)	0.30	0.25	0.20	0.15	0.15	0.15
Endurance (85°C)	Test time	1000 hours (with the polarity inverted every 250 hours)					
	Leakage current	The initial specified value or less					
	Percentage of capacitance change	Within ±20% of initial value					
	Tangent of the loss angle	200% or less of the initial specified value					
Applicable standards	JIS C5101-1, -4 1998 (IEC 60384-1 1992, -4 1985)						

Outline Drawing

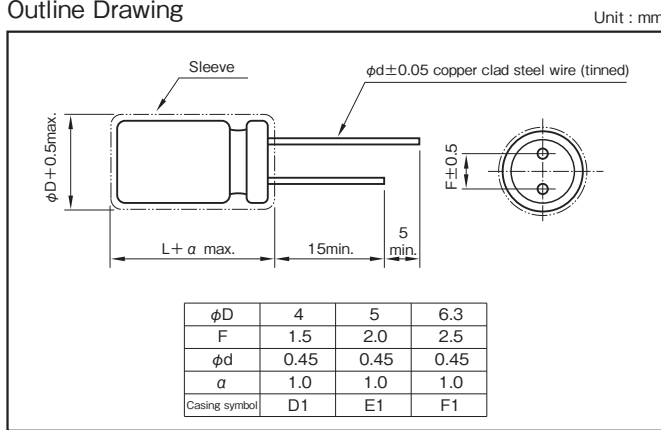

Coefficient of Frequency for Rated Ripple Current

Rated voltage (V)	Frequency (Hz)			
	50 · 60	120	1k	10k · 100k
6.3 to 16	0.8	1	1.1	1.2
25 to 35	0.8	1	1.5	1.7
50	0.8	1	1.6	1.9

Part numbering system (example: 16V47μF)

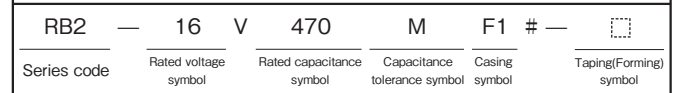

Standard Ratings

Rated voltage (V)	6.3		10		16		25		35		50	
	Case	Rated ripple current	Case	Rated ripple current	Case	Rated ripple current	Case	Rated ripple current	Case	Rated ripple current	Case	Rated ripple current
Rated capacitance (μF)	φD×L (mm)	(mArms)	φD×L (mm)	(mArms)	φD×L (mm)	(mArms)	φD×L (mm)	(mArms)	φD×L (mm)	(mArms)	φD×L (mm)	(mArms)
0.22	—	—	—	—	—	—	—	—	—	—	4×7	4
0.33	—	—	—	—	—	—	—	—	—	—	4×7	5
0.47	—	—	—	—	—	—	—	—	—	—	4×7	6
1	—	—	—	—	—	—	—	—	—	—	4×7	9
2.2	—	—	—	—	—	—	—	—	4×7	14	5×7	16
3.3	—	—	—	—	—	—	4×7	17	5×7	19	5×7	19
4.7	—	—	—	—	4×7	17	5×7	23	5×7	23	6.3×7	27
10	—	—	4×7	23	5×7	29	6.3×7	39	6.3×7	39	—	—
22	5×7	35	5×7	39	6.3×7	50	6.3×7	58	—	—	—	—
33	5×7	43	6.3×7	55	6.3×7	61	6.3×7	71	—	—	—	—
47	6.3×7	60	6.3×7	66	6.3×7	73	—	—	—	—	—	—

(Note) Rated ripple current : 85°C, 120Hz.

NOTE

Design, Specifications are subject to change without notice. Ask factory for technical specifications before purchase and/or use.

Standard Capacitors

GREEN CAP

Anti-cleaning solvent 250V Max.

• Guarantees 2000 hours at 85°C.

RJ4

High temperature

RE3

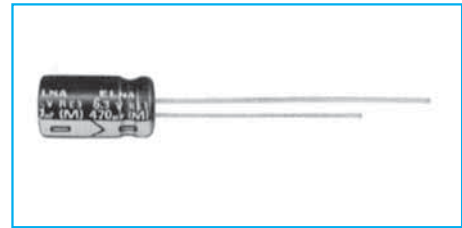

Marking color : White print on a blue sleeve

Specifications

Item	Performance																																															
Category temperature range (°C)	-40 to +85																																															
Tolerance at rated capacitance (%)	±20 (20°C, 120Hz)																																															
Leakage current (µA)	<table border="1"> <tr> <td>Rated voltage (V)</td> <td>6.3 to 100</td> <td>160 to 450</td> </tr> <tr> <td>Leakage current (µA)</td> <td>Less than 0.03CV or 4 whichever is larger (after 1 minute) Less than 0.01CV or 3 whichever is larger (after 2 minutes)</td> <td>CV ≤ 1000 : Less than 0.1CV + 40 (after 1 minute) CV > 1000 : Less than 0.04CV + 100 (after 1 minute)</td> </tr> </table>	Rated voltage (V)	6.3 to 100	160 to 450	Leakage current (µA)	Less than 0.03CV or 4 whichever is larger (after 1 minute) Less than 0.01CV or 3 whichever is larger (after 2 minutes)	CV ≤ 1000 : Less than 0.1CV + 40 (after 1 minute) CV > 1000 : Less than 0.04CV + 100 (after 1 minute)																																									
	Rated voltage (V)	6.3 to 100	160 to 450																																													
Leakage current (µA)	Less than 0.03CV or 4 whichever is larger (after 1 minute) Less than 0.01CV or 3 whichever is larger (after 2 minutes)	CV ≤ 1000 : Less than 0.1CV + 40 (after 1 minute) CV > 1000 : Less than 0.04CV + 100 (after 1 minute)																																														
C : Rated capacitance (µF) V : Rated voltage (V) (20°C)																																																
Tangent of loss angle (tanδ)	<table border="1"> <tr> <td>Rated voltage (V)</td> <td>6.3</td><td>10</td><td>16</td><td>25</td><td>35</td><td>50</td><td>63</td><td>100</td><td>160</td><td>200</td><td>250</td><td>315</td><td>350</td><td>400</td><td>450</td> </tr> <tr> <td>tanδ (max.)</td> <td>0.28</td><td>0.24</td><td>0.20</td><td>0.16</td><td>0.14</td><td>0.12</td><td>0.10</td><td>0.08</td><td>0.20</td><td>0.20</td><td>0.20</td><td>0.24</td><td>0.24</td><td>0.24</td><td>0.24</td> </tr> </table>	Rated voltage (V)	6.3	10	16	25	35	50	63	100	160	200	250	315	350	400	450	tanδ (max.)	0.28	0.24	0.20	0.16	0.14	0.12	0.10	0.08	0.20	0.20	0.20	0.24	0.24	0.24	0.24															
	Rated voltage (V)	6.3	10	16	25	35	50	63	100	160	200	250	315	350	400	450																																
tanδ (max.)	0.28	0.24	0.20	0.16	0.14	0.12	0.10	0.08	0.20	0.20	0.20	0.24	0.24	0.24	0.24																																	
0.02 is added to every 1000µF increase over 1000µF. (20°C, 120Hz)																																																
Characteristics at high and low temperature	<table border="1"> <tr> <td>Rated voltage (V)</td> <td>6.3</td><td>10</td><td>16</td><td>25</td><td>35</td><td>50</td><td>63</td><td>100</td><td>160</td><td>200</td><td>250</td><td>315</td><td>350</td><td>400</td><td>450</td> </tr> <tr> <td rowspan="2">Impedance ratio (max.)</td> <td>Z-25°C/Z+20°C</td> <td>5</td><td>4</td><td>3</td><td>2</td><td>2</td><td>2</td><td>2</td><td>4</td><td>4</td><td>4</td><td>4</td><td>4</td><td>4</td><td>4</td> </tr> <tr> <td>Z-40°C/Z+20°C</td> <td>12</td><td>10</td><td>8</td><td>5</td><td>4</td><td>3</td><td>3</td><td>3</td><td>15</td><td>15</td><td>15</td><td>10</td><td>10</td><td>10</td> </tr> </table>	Rated voltage (V)	6.3	10	16	25	35	50	63	100	160	200	250	315	350	400	450	Impedance ratio (max.)	Z-25°C/Z+20°C	5	4	3	2	2	2	2	4	4	4	4	4	4	4	Z-40°C/Z+20°C	12	10	8	5	4	3	3	3	15	15	15	10	10	10
	Rated voltage (V)	6.3	10	16	25	35	50	63	100	160	200	250	315	350	400	450																																
Impedance ratio (max.)	Z-25°C/Z+20°C	5	4	3	2	2	2	2	4	4	4	4	4	4	4																																	
	Z-40°C/Z+20°C	12	10	8	5	4	3	3	3	15	15	15	10	10	10																																	
(120Hz)																																																
Endurance (85°C) (Applied ripple current)	Test time	2000 hours																																														
	Leakage current	The initial specified value or less																																														
	Percentage of capacitance change	Within ±20% of initial value																																														
	Tangent of the loss angle	200% or less of the initial specified value																																														
Shelf life (85°C)	Test time : 1000 hours ; other items are the same as those for the endurance. Voltage application treatment																																															
Applicable standards	JIS C5101-1, -4 1998 (IEC 60384-1 1992, -4 1985)																																															

Outline Drawing

Unit : mm

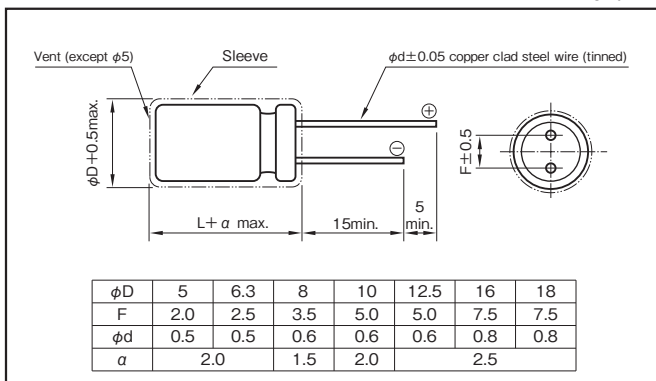

Coefficient of Frequency for Rated Ripple Current

Rated voltage (V)	Frequency (Hz) CV (µF×VV)	50 · 60	120	1k	10k	100k
		6.3 to 16	All CV value	0.8	1	1.1
25 to 35	≤ 1000	0.8	1	1.5	1.7	1.7
	1000 <	0.8	1	1.2	1.3	1.3
50 to 100	≤ 1000	0.8	1	1.6	1.9	1.9
	1000 <	0.8	1	1.2	1.3	1.3
160 to 450	All CV value	0.8	1	1.3	1.5	1.6

Part numbering system (example : 16V1000µF)

RE3	—	16	V	102	M	H4	#	□	—	□
Series code		Rated voltage symbol		Rated capacitance symbol	Capacitance tolerance symbol	Casing symbol	Optional symbol			Taping/Forming symbol

Casing symbol

Size φD×L (mm)	Casing Symbol	Size φD×L (mm)	Casing Symbol
5×11	E3	12.5×25	I6
6.3×11	F3	16×25	J6
8×11.5	G3	16×31.5	J7
10×12.5	H3	16×35.5	J8
10×16	H4	18×35.5	K8
10×20	H5	18×40	K9
12.5×20	I5		

NOTE

Design, Specifications are subject to change without notice. Ask factory for technical specifications before purchase and/or use.

Standard Ratings

Rated voltage (V)	Item	6.3			10			16			25			35			50			63			100		
		Case	ESR	Rated ripple current	Case	ESR	Rated ripple current	Case	ESR	Rated ripple current	Case	ESR	Rated ripple current	Case	ESR	Rated ripple current	Case	ESR	Rated ripple current	Case	ESR	Rated ripple current	Case	ESR	Rated ripple current
		φD×L (mm)	(Ω)	(mA _{rms})	φD×L (mm)	(Ω)	(mA _{rms})	φD×L (mm)	(Ω)	(mA _{rms})	φD×L (mm)	(Ω)	(mA _{rms})	φD×L (mm)	(Ω)	(mA _{rms})	φD×L (mm)	(Ω)	(mA _{rms})	φD×L (mm)	(Ω)	(mA _{rms})	φD×L (mm)	(Ω)	(mA _{rms})
1	—	—	—	—	—	—	—	—	—	—	—	—	—	—	—	5×11	199	21	—	—	—	5×11	133	21	
2.2	—	—	—	—	—	—	—	—	—	—	—	—	—	—	—	5×11	90.5	31	—	—	—	5×11	60.3	30	
3.3	—	—	—	—	—	—	—	—	—	—	—	—	—	—	—	5×11	60.3	38	—	—	—	5×11	40.2	40	
4.7	—	—	—	—	—	—	—	—	—	5×11	56.5	38	5×11	49.4	40	5×11	42.3	45	5×11	35.3	45	5×11	28.2	45	
10	—	—	—	—	—	—	5×11	33.2	50	5×11	26.5	55	5×11	23.2	59	5×11	19.9	66	5×11	16.6	66	6.3×11	13.3	75	
22	—	—	—	—	—	—	5×11	15.1	75	5×11	12.1	82	5×11	10.6	87	5×11	9.05	98	5×11	7.54	100	6.3×11	6.03	130	
33	—	—	—	—	—	—	5×11	10.1	92	5×11	8.04	100	5×11	7.04	107	5×11	6.03	126	6.3×11	5.03	140	8×11.5	4.02	180	
47	—	—	—	5×11	8.47	99	5×11	7.06	110	5×11	5.65	118	5×11	4.94	130	6.3×11	4.23	155	6.3×11	3.53	170	10×12.5	2.82	230	
100	—	—	—	5×11	3.78	146	5×11	3.32	160	6.3×11	2.65	199	6.3×11	2.32	214	8×11.5	1.99	260	10×12.5	1.66	300	10×20	1.33	370	
220	5×11	2.11	200	6.3×11	1.81	240	6.3×11	1.51	264	8×11.5	1.21	349	10×12.5	1.06	443	10×12.5	0.905	443	10×16	7.54	470	12.5×20	0.603	620	
330	6.3×11	1.41	270	6.3×11	1.21	290	8×11.5	1.01	383	10×12.5	0.804	510	10×12.5	0.704	542	10×16	0.603	595	10×20	0.503	710	12.5×25	0.402	760	
470	6.3×11	0.988	322	8×11.5	0.847	417	8×11.5	0.706	457	10×12.5	0.565	545	10×16	0.494	664	12.5×20	0.423	887	12.5×20	0.353	900	16×25	0.282	1000	
1000	8×11.5	0.464	546	10×12.5	0.398	650	10×16	0.332	791	10×20	0.265	996	12.5×20	0.232	1210	12.5×25	0.199	1400	16×25	0.166	1300	18×40	0.133	1380	
2200	10×20	0.226	1010	10×20	0.196	1080	12.5×20	0.166	1350	12.5×25	0.136	1660	16×25	0.121	1950	16×35.5	0.106	2340	—	—	—	—	—	—	
3300	10×20	0.161	1230	12.5×20	0.141	1430	12.5×25	0.121	1690	16×25	0.101	2030	16×35.5	0.09	2510	18×35.5	0.08	2810	—	—	—	—	—	—	
4700	12.5×20	0.12	1710	12.5×25	0.106	1780	16×25	0.092	2100	16×31.5	0.078	2650	18×35.5	0.071	2990	—	—	—	—	—	—	—	—	—	
6800	12.5×25	0.093	1930	16×25	0.083	2200	16×35.5	0.073	2580	18×35.5	0.063	3290	—	—	—	—	—	—	—	—	—	—	—	—	
10000	16×25	0.076	2450	16×35.5	0.07	2700	18×35.5	0.063	3130	—	—	—	—	—	—	—	—	—	—	—	—	—	—	—	
15000	16×35.5	0.062	2860	18×35.5	0.058	3100	—	—	—	—	—	—	—	—	—	—	—	—	—	—	—	—	—	—	
22000	18×40	0.053	3340	—	—	—	—	—	—	—	—	—	—	—	—	—	—	—	—	—	—	—	—	—	

Rated voltage (V)	Item	160			200			250			315			350			400			450			
		Case	ESR	Rated ripple current	Case	ESR	Rated ripple current	Case	ESR	Rated ripple current	Case	ESR	Rated ripple current	Case	ESR	Rated ripple current	Case	ESR	Rated ripple current	Case	ESR	Rated ripple current	
		φD×L (mm)	(Ω)	(mA _{rms})	φD×L (mm)	(Ω)	(mA _{rms})	φD×L (mm)	(Ω)	(mA _{rms})	φD×L (mm)	(Ω)	(mA _{rms})	φD×L (mm)	(Ω)	(mA _{rms})	φD×L (mm)	(Ω)	(mA _{rms})	φD×L (mm)	(Ω)	(mA _{rms})	
0.47	6.3×11	706	15	6.3×11	706	15	6.3×11	706	15	6.3×11	847	15	6.3×11	847	15	6.3×11	847	15	8×11.5	847	18		
1	6.3×11	332	22	6.3×11	332	22	6.3×11	332	22	6.3×11	398	22	6.3×11	398	22	6.3×11	398	22	8×11.5	398	25		
2.2	6.3×11	151	32	6.3×11	151	32	6.3×11	151	32	8×11.5	181	38	8×11.5	181	38	8×11.5	181	38	10×12.5	181	43		
3.3	6.3×11	101	40	6.3×11	101	40	8×11.5	101	48	10×12.5	121	53	10×12.5	121	53	10×12.5	121	54	10×16	121	59		
4.7	6.3×11	70.6	48	8×11.5	70.6	56	8×11.5	70.6	56	10×12.5	84.7	65	10×12.5	84.7	65	10×16	84.7	71	10×20	84.7	76		
10	8×11.5	33.2	81	10×12.5	33.2	94	10×16	33.2	101	10×20	39.8	115	10×20	39.8	115	12.5×20	39.8	123	12.5×20	39.8	123		
22	10×16	15.1	151	10×20	15.1	170	12.5×20	15.1	182	12.5×20	18.1	182	12.5×25	18.1	197	12.5×25	18.1	197	16×25	18.1	226		
33	10×20	10.1	202	12.5×20	10.1	223	12.5×25	10.1	243	16×25	12.1	277	16×25	12.1	277	16×25	12.1	277	16×31.5	12.1	304		
47	12.5×20	7.06	266	12.5×25	7.06	265	12.5×25	7.06	295	16×25	8.47	330	16×25	8.47	330	16×31.5	8.47	361	16×35.5	8.47	380		
100	12.5×25	3.32	422	16×25	3.32	483	16×31.5	3.32	528	18×31.5	3.98	567	18×31.5	3.98	567	—	—	—	—	—	—	—	—
220	16×31.5	1.51	783	18×35.5	1.51	882	—	—	—	—	—	—	—	—	—	—	—	—	—	—	—	—	—
330	18×35.5	1.01	1080	—	—	—	—	—	—	—	—	—	—	—	—	—	—	—	—	—	—	—	—

(Note) ESR : 20°C, 120Hz ; Rated ripple current : 85°C, 120Hz

Standard Bipolar Capacitors

GREEN CAP Anti-cleaning solvent

• Guarantees 2000 hours at 85°C.



Marking color : White print on a blue sleeve

Specifications

Item	Performance									
Category temperature range (°C)	-40 to +85									
Tolerance at rated capacitance (%)	±20 (20°C, 120Hz)									
Leakage current (µA)	Less than 0.03CV + 3 (after 5 minutes) C : Rated capacitance (µF) ; V : Rated voltage (V) (20°C)									
Tangent of loss angle (tanδ)	Rated voltage (V)		6.3	10	16	25	35	50	63	100
	tan δ (max.)		0.24	0.24	0.20	0.20	0.16	0.14	0.12	0.10
0.02 is added to every 1000µF increase over 1000µF (20°C, 120Hz)										
Characteristics at high and low temperature	Rated voltage (V)		6.3	10	16	25	35	50	63	100
	Impedance ratio (max.)	Z-25°C/Z+20°C	4	3	2	2	2	2	2	2
		Z-40°C/Z+20°C	10	8	6	4	3	3	3	3
0.5 for -25°C, 1 for -40°C are added to every 1000µF increase over 1000µF (120Hz)										
Endurance (85°C) (Applied ripple current)	Test time		2000 hours (with the polarity inverted every 250 hours)							
	Leakage current		The initial specified value or less							
	Percentage of capacitance change		Within ±20% of initial value							
	Tangent of the loss angle		150% or less of the initial specified value							
Shelf life (85°C)	Test time : 1000 hours. Other have same as endurance. Voltage application treatment									
Applicable standards	JIS C5101-1, -4 1998 (IEC 60384-1 1992, -4 1985)									

Outline Drawing

Unit : mm

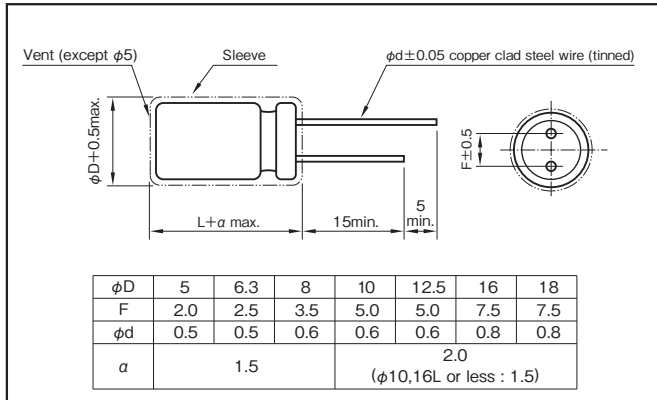

Coefficient of Frequency for Rated Ripple Current

Rated voltage (V) \ Frequency (Hz)	50 · 60	120	1k	10k · 100k
6.3 to 16	0.8	1	1.1	1.2
25 to 35	0.8	1	1.5	1.7
50 to 100	0.8	1	1.6	1.9

Part numbering system (example : 10V1000µF)

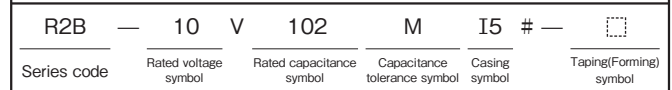

Casing symbol

Case φD×L (mm)	Casing Symbol	Case φD×L (mm)	Casing Symbol	Case φD×L (mm)	Casing Symbol	Case φD×L (mm)	Casing Symbol
5×11	E3	10×12.5	H3	12.5×20	I5	16×31.5	J7
6.3×11	F3	10×16	H4	12.5×25	I6	16×35.5	J8
8×11.5	G3	10×20	H5	16×25	J6	18×35.5	K8

Standard Ratings

Rated capacitance (µF) \ Rated voltage (V)	6.3		10		16		25		35		50		63		100	
	Case φD×L (mm)	Rated ripple current (mA rms)	Case φD×L (mm)	Rated ripple current (mA rms)	Case φD×L (mm)	Rated ripple current (mA rms)	Case φD×L (mm)	Rated ripple current (mA rms)	Case φD×L (mm)	Rated ripple current (mA rms)	Case φD×L (mm)	Rated ripple current (mA rms)	Case φD×L (mm)	Rated ripple current (mA rms)	Case φD×L (mm)	Rated ripple current (mA rms)
0.47	—	—	—	—	—	—	—	—	—	—	5×11	10	—	—	5×11	11
1	—	—	—	—	—	—	—	—	—	—	5×11	14	—	—	5×11	16
2.2	—	—	—	—	—	—	—	—	—	—	5×11	21	5×11	23	5×11	24
3.3	—	—	—	—	—	—	—	—	—	—	5×11	26	5×11	28	6.3×11	34
4.7	—	—	—	—	—	—	5×11	28	5×11	28	5×11	31	5×11	34	6.3×11	41
10	—	—	—	—	5×11	39	5×11	40	5×11	42	5×11	45	6.3×11	57	8×11.5	70
22	—	—	5×11	52	5×11	58	5×11	60	6.3×11	71	6.3×11	77	8×11.5	89	10×16	136
33	5×11	58	5×11	63	5×11	71	6.3×11	84	6.3×11	87	8×11.5	111	10×12.5	144	10×20	181
47	5×11	69	5×11	75	6.3×11	97	6.3×11	100	8×11.5	122	10×12.5	157	10×16	188	12.5×20	248
100	6.3×11	115	6.3×11	126	8×11.5	167	10×12.5	204	10×12.5	212	10×20	273	12.5×20	343	16×25	458
220	8×11.5	202	8×11.5	221	10×12.5	294	10×16	332	10×20	375	12.5×25	506	16×25	645	18×35.5	837
330	8×11.5	247	10×12.5	322	10×16	394	10×20	444	12.5×20	526	12.5×25	620	—	—	—	—
470	10×12.5	350	10×16	420	10×20	513	12.5×20	607	12.5×25	685	16×25	861	—	—	—	—
1000	10×20	611	12.5×20	767	12.5×25	935	16×25	1120	16×31.5	1270	—	—	—	—	—	—
2200	12.5×25	1090	16×25	1380	16×31.5	1660	—	—	—	—	—	—	—	—	—	—
3300	16×25	1490	16×31.5	1760	—	—	—	—	—	—	—	—	—	—	—	—
4700	16×31.5	1880	18×35.5	2280	—	—	—	—	—	—	—	—	—	—	—	—

(Note) Rated ripple current : 85°C, 120Hz

NOTE

Design, Specifications are subject to change without notice. Ask factory for technical specifications before purchase and/or use.

105°C Bipolar Capacitors

GREEN CAP Anti-cleaning solvent

• Guarantees 2000 hours at 105°C.



High temperature

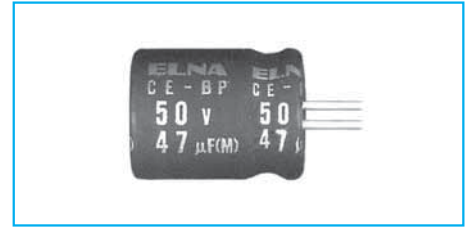

Marking color : White print on a black sleeve

Specifications

Item	Performance	
Category temperature range (°C)	-40 to +105	
Tolerance at rated capacitance (%)	±20 (20°C,120Hz)	
Leakage current (µA)	Less than 0.03CV + 3 (after 5 minutes) C : Rated capacitance (µF) ; V : Rated voltage (V) (20°C)	
Tangent of loss angle (tanδ)	Rated voltage (V)	6.3 10 16 25 35 50
	tan δ (max.)	0.4 0.3 0.2 0.2 0.16 0.14
0.02 is added to every 1000µF increase over 1000µF (20°C,120Hz)		
Characteristics at high and low temperature	Rated voltage (V)	6.3 10 16 25 35 50
	Impedance ratio (max.)	Z-25°C/Z+20°C 5 4 3 2 2 2 Z-40°C/Z+20°C 10 8 6 4 3 3
0.5 for -25°C, 1 for -40°C are added to every 1000µF increase over 1000µF (120Hz)		
Endurance (105°C) (Applied ripple current)	Test time	2000 hours (with the polarity inverted every 250 hours)
	Leakage current	The initial specified value or less
	Percentage of capacitance change	Within ±20% of initial value
	Tangent of the loss angle	200% or less of the initial specified value
Shelf life (105°C)	Test time : 1000 hours. Other have same as endurance. Voltage application treatment	
Applicable standards	JIS C5101-1, -4 1998 (IEC 60384-1 1992, -4 1985)	

Outline Drawing

Unit : mm

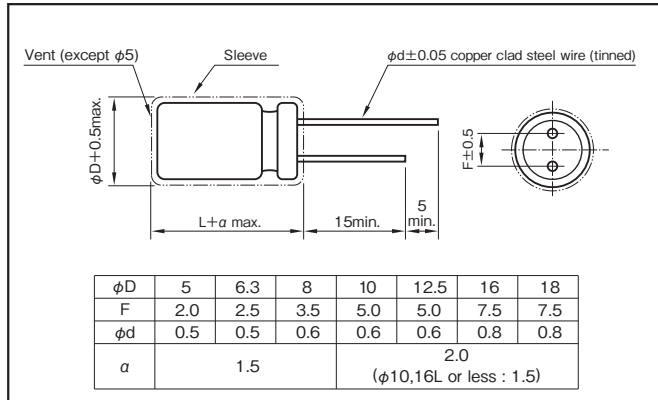

Coefficient of Frequency for Rated Ripple Current

Rated voltage (V) \ Frequency (Hz)	50 · 60	120	1k	10k · 100k
6.3 to 16	0.8	1	1.1	1.2
25 to 35	0.8	1	1.5	1.7
50	0.8	1	1.6	1.9

Part numbering system (example : 10V1000µF)

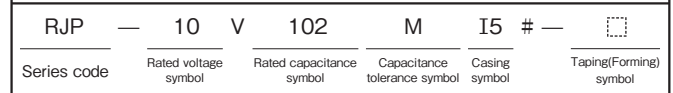

Casing symbol

Case φD×L (mm)	Casing Symbol	Case φD×L (mm)	Casing Symbol	Case φD×L (mm)	Casing Symbol	Case φD×L (mm)	Casing Symbol
5×11	E3	10×12.5	H3	12.5×20	I5	16×31.5	J7
6.3×11	F3	10×16	H4	12.5×25	J6	18×35.5	K8
8×11.5	G3	10×20	H5	16×25			

Standard Ratings

Rated capacitance (µF) \ Rated voltage (V)	6.3		10		16		25		35		50	
	Case φD×L (mm)	Rated ripple current (mA rms)	Case φD×L (mm)	Rated ripple current (mA rms)	Case φD×L (mm)	Rated ripple current (mA rms)	Case φD×L (mm)	Rated ripple current (mA rms)	Case φD×L (mm)	Rated ripple current (mA rms)	Case φD×L (mm)	Rated ripple current (mA rms)
1	—	—	—	—	—	—	—	—	—	—	5×11	12
2.2	—	—	—	—	—	—	—	—	—	—	5×11	18
3.3	—	—	—	—	—	—	—	—	—	—	5×11	22
4.7	—	—	—	—	—	—	—	—	5×11	25	5×11	22
10	—	—	—	—	5×11	30	5×11	34	5×11	30	6.3×11	37
22	—	—	5×11	42	5×11	40	6.3×11	55	6.3×11	51	8×11.5	63
33	5×11	46	5×11	45	5×11	49	6.3×11	56	8×11.5	72	8×11.5	77
47	5×11	54	5×11	54	6.3×11	67	6.3×11	67	8×11.5	86	10×12.5	105
100	6.3×11	90	6.3×11	96	8×11.5	110	8×11.5	110	10×16	160	10×20	190
220	8×11.5	150	8×11.5	150	10×12.5	195	10×16	215	12.5×20	290	12.5×25	340
330	8×11.5	185	10×16	240	10×16	265	12.5×20	320	12.5×20	350	16×25	460
470	10×12.5	260	10×16	290	10×20	345	12.5×20	380	12.5×25	465	16×31.5	590
1000	10×20	460	12.5×20	510	12.5×25	605	16×25	670	16×31.5	805	—	—
2200	12.5×25	820	16×25	910	16×31.5	1070	18×35.5	1140	—	—	—	—
3300	16×25	1110	16×31.5	1200	18×35.5	1400	—	—	—	—	—	—
4700	16×31.5	1430	18×35.5	1520	—	—	—	—	—	—	—	—
6800	18×35.5	1830	—	—	—	—	—	—	—	—	—	—

(Note) Rated ripple current : 105°C, 120Hz

NOTE

Design, Specifications are subject to change without notice. Ask factory for technical specifications before purchase and/or use.

105°C Miniature Capacitors

GREEN CAP 105°C 1000hours Anti-cleaning solvent

• Case size is one rank smaller than Series RJ4.

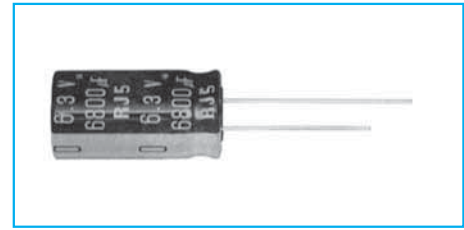
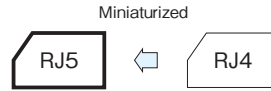

Marking color : White print on a black sleeve

Specifications

Item	Performance																																				
Category temperature range (°C)	-55~+105	-40~+105																																			
Rated voltage (V)	6.3~100	160~450																																			
Tolerance at rated capacitance (%)	±20 (20°C, 120Hz)	±20 (20°C, 120Hz)																																			
Leakage current (µA)	Less than 0.03CV or 4 whichever is larger (after 1 minute) Less than 0.01CV or 3 whichever is larger (after 2 minutes) (20°C)	CV≤1000 : Less than 0.1CV+40 (after 1 minute) CV>1000 : Less than 0.04CV+100 (after 1 minute) (20°C)																																			
Tangent of loss angle (tanδ)	C : Rated capacitance (µF) V : Rated voltage (V)																																				
	<table border="1"> <tr> <th>Rated voltage (V)</th> <td>6.3</td><td>10</td><td>16</td><td>25</td><td>35</td><td>50</td><td>63</td><td>100</td> </tr> <tr> <th>tanδ (max.)</th> <td>0.34</td><td>0.26</td><td>0.20</td><td>0.16</td><td>0.14</td><td>0.12</td><td>0.10</td><td>0.08</td> </tr> </table> <p>0.02 is added to every 1000µF increase over 1000µF. (20°C, 120Hz)</p>	Rated voltage (V)	6.3	10	16	25	35	50	63	100	tanδ (max.)	0.34	0.26	0.20	0.16	0.14	0.12	0.10	0.08	<table border="1"> <tr> <th>Rated voltage (V)</th> <td>160</td><td>200</td><td>250</td><td>315</td><td>350</td><td>400</td><td>450</td> </tr> <tr> <th>tanδ (max.)</th> <td>0.20</td><td>0.20</td><td>0.20</td><td>0.24</td><td>0.24</td><td>0.24</td><td>0.24</td> </tr> </table> <p>(20°C, 120Hz)</p>	Rated voltage (V)	160	200	250	315	350	400	450	tanδ (max.)	0.20	0.20	0.20	0.24	0.24	0.24	0.24	
	Rated voltage (V)	6.3	10	16	25	35	50	63	100																												
tanδ (max.)	0.34	0.26	0.20	0.16	0.14	0.12	0.10	0.08																													
Rated voltage (V)	160	200	250	315	350	400	450																														
tanδ (max.)	0.20	0.20	0.20	0.24	0.24	0.24	0.24																														
<table border="1"> <tr> <th>Rated voltage (V)</th> <td>6.3</td><td>10</td><td>16</td><td>25</td><td>35</td><td>50</td><td>63</td><td>100</td> </tr> <tr> <th>Impedance ratio (max.)</th> <td>Z-25°C/Z+20°C</td><td>5</td><td>4</td><td>3</td><td>2</td><td>2</td><td>2</td><td>2</td> </tr> <tr> <th></th> <td>Z-40°C/Z+20°C</td><td>10</td><td>8</td><td>6</td><td>4</td><td>3</td><td>3</td><td>3</td> </tr> </table> <p>(120Hz)</p>	Rated voltage (V)	6.3	10	16	25	35	50	63	100	Impedance ratio (max.)	Z-25°C/Z+20°C	5	4	3	2	2	2	2		Z-40°C/Z+20°C	10	8	6	4	3	3	3	<table border="1"> <tr> <th>Rated voltage (V)</th> <td>160 to 250</td><td>315 to 450</td> </tr> <tr> <th>Impedance ratio (max.)</th> <td>Z-25°C/Z+20°C</td><td>4</td> </tr> <tr> <th></th> <td>Z-40°C/Z+20°C</td><td>15</td> </tr> </table> <p>(120Hz)</p>	Rated voltage (V)	160 to 250	315 to 450	Impedance ratio (max.)	Z-25°C/Z+20°C	4		Z-40°C/Z+20°C	15
Rated voltage (V)	6.3	10	16	25	35	50	63	100																													
Impedance ratio (max.)	Z-25°C/Z+20°C	5	4	3	2	2	2	2																													
	Z-40°C/Z+20°C	10	8	6	4	3	3	3																													
Rated voltage (V)	160 to 250	315 to 450																																			
Impedance ratio (max.)	Z-25°C/Z+20°C	4																																			
	Z-40°C/Z+20°C	15																																			
Endurance (105°C) (Applied ripple current)	Test time	2000 hours (φ5 to φ8, 100V or less : 1000 hours)																																			
	Leakage current	The initial specified value or less																																			
	Percentage of capacitance change	Within ±20% of initial value																																			
	Tangent of the loss angle	200% or less of the initial specified value																																			
Shelf life (105°C)	Test time : 1000 hours ; other items are the same as those for the endurance. Voltage application treatment																																				
Applicable standards	JIS C5101-1, -4 1998 (IEC 60384-1 1992, -4 1985)																																				

Outline Drawing

Unit : mm

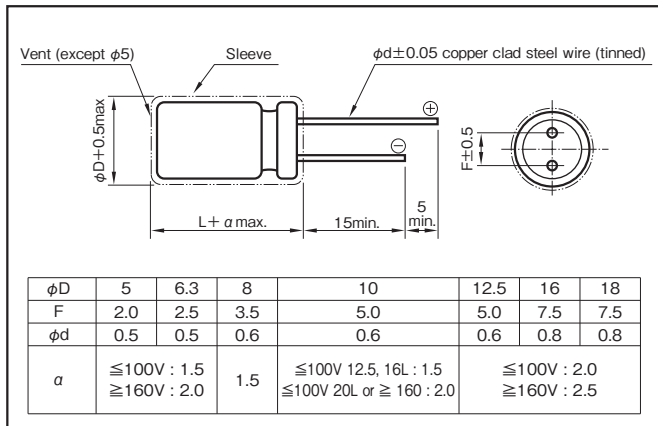

Coefficient of Frequency for Rated Ripple Current

Rated voltage (V)	Rated capacitance (µF)	Frequency (Hz)				
		50 · 60	120	1k	10k	100k
6.3 to 100	0.1 to 47	0.8	1	1.5	1.7	2.0
	100 to 220	0.8	1	1.2	1.3	1.4
	330 to 1000	0.8	1	1.2	1.2	1.3
	2200 to 22000	0.8	1	1.1	1.1	1.1
160 to 450	0.47 to 470	0.8	1	1.3	1.4	1.6

Part numbering system (example : 10V1000µF)

RJ5	—	10	V	102	M	H3	#	□	—	□
Series code		Rated voltage symbol		Rated capacitance symbol	Capacitance tolerance symbol	Casing symbol	Optional symbol			Taping/Forming symbol

In the case of 160V and beyond, should put in optional symbol "B".

Casing symbol

Size φD×L (mm)	Casing Symbol	Size φD×L (mm)	Casing Symbol	Size φD×L (mm)	Casing Symbol	Size φD×L (mm)	Casing Symbol
5×11	E3	10×12.5	H3	16×20	J5	18×20	K5
6.3×11	F3	10×16	H4	16×25	J6	18×25	K6
8×11.5	G3	10×20	H5	16×31.5	J7	18×31.5	K7
—	—	12.5×20	I5	16×35.5	J8	18×35.5	K8
—	—	12.5×25	I6	—	—	18×40	K9

NOTE

Design, Specifications are subject to change without notice. Ask factory for technical specifications before purchase and/or use.

Standard Ratings

Rated voltage (V)	6.3		10		16		25		35		50		63		100		
	Item	Case	Rated ripple current	Case	Rated ripple current	Case	Rated ripple current	Case	Rated ripple current	Case	Rated ripple current	Case	Rated ripple current	Case	Rated ripple current	Case	Rated ripple current
		Rated capacitance (μF)	φD×L (mm)	mArms	φD×L (mm)	mArms	φD×L (mm)	mArms	φD×L (mm)	mArms	φD×L (mm)	mArms	φD×L (mm)	mArms	φD×L (mm)	mArms	φD×L (mm)
1	—	—	—	—	—	—	—	—	—	—	5×11	15	—	—	5×11	15	
2.2	—	—	—	—	—	—	—	—	—	—	5×11	22	—	—	5×11	21	
3.3	—	—	—	—	—	—	—	—	—	—	5×11	27	—	—	5×11	29	
4.7	—	—	—	—	—	—	—	—	—	—	5×11	32	—	—	5×11	32	
10	—	—	—	—	—	—	—	—	—	—	5×11	47	—	—	5×11	50	
22	—	—	—	—	—	—	—	—	—	—	5×11	70	5×11	71	6.3×11	93	
33	—	—	—	—	—	—	—	—	—	—	5×11	90	6.3×11	100	8×11.5	130	
47	—	—	—	—	—	—	—	—	5×11	93	6.3×11	115	6.3×11	120	8×11.5	140	
68	—	—	—	—	—	—	—	—	6.3×11	110	6.3×11	150	8×11.5	155	10×12.5	190	
100	—	—	—	—	—	—	5×11	125	6.3×11	151	8×11.5	190	8×11.5	200	10×16	240	
220	—	—	5×11	155	6.3×11	190	6.3×11	200	8×11.5	270	10×12.5	314	10×16	335	12.5×20	390	
330	—	—	6.3×11	210	6.3×11	225	8×11.5	310	10×12.5	384	10×16	421	10×20	510	—	—	
470	—	—	6.3×11	250	8×11.5	323	10×12.5	429	10×16	470	10×20	540	12.5×20	640	16×25	715	
1000	8×11.5	398	10×12.5	460	10×12.5	500	10×16	610	12.5×20	857	12.5×25	1000	16×25	930	18×35.5	960	
2200	10×16	635	10×16	705	10×20	710	12.5×25	1180	16×25	1380	16×31.5	1410	18×35.5	1650	—	—	
3300	10×20	882	12.5×20	1010	12.5×25	1200	16×25	1440	16×31.5	1500	18×35.5	1990	—	—	—	—	
4700	12.5×20	1120	12.5×25	1260	16×25	1500	16×25	1570	16×35.5	1780	—	—	—	—	—	—	
6800	12.5×25	1380	16×25	1570	16×25	1600	16×35.5	1850	18×40	2000	—	—	—	—	—	—	
10000	16×25	1750	16×31.5	1820	16×35.5	1930	18×40	2000	—	—	—	—	—	—	—	—	
15000	16×31.5	1820	16×35.5	2050	18×40	2210	—	—	—	—	—	—	—	—	—	—	
22000	18×35.5	2280	18×40	2420	—	—	—	—	—	—	—	—	—	—	—	—	

Rated voltage (V)	160		200		250		315		350		400		450		
	Item	Case	Rated ripple current	Case	Rated ripple current	Case	Rated ripple current	Case	Rated ripple current	Case	Rated ripple current	Case	Rated ripple current	Case	Rated ripple current
		Rated capacitance (μF)	φD×L (mm)	(mArms)	φD×L (mm)	(mArms)	φD×L (mm)	(mArms)	φD×L (mm)	(mArms)	φD×L (mm)	(mArms)	φD×L (mm)	(mArms)	φD×L (mm)
1	—	—	—	—	—	—	—	—	—	—	—	—	6.3×11	12	
2.2	—	—	—	—	—	—	6.3×11	21	6.3×11	21	—	—	8×11.5	20	
3.3	—	—	—	—	6.3×11	35	6.3×11	26	6.3×11	26	—	—	10×12.5	41	
4.7	—	—	6.3×11	42	6.3×11	42	8×11.5	35	8×11.5	35	8×11.5	35	10×12.5	49	
10	6.3×11	61	8×11.5	72	8×11.5	72	10×16	74	10×16	67	10×16	67	10×20	86	
22	10×12.5	125	10×16	135	10×16	135	12.5×20	135	12.5×20	140	12.5×20	140	12.5×25	170	
33	10×16	170	10×20	185	12.5×20	210	12.5×25	195	12.5×25	195	12.5×25	195	16×20	225	
47	10×20	220	—	—	12.5×20	250	—	—	—	—	16×25	350	16×25	296	
68	12.5×25	330	12.5×20	305	16×20	355	18×20	350	16×31.5	390	16×31.5	460	16×31.5	390	
100	16×20	430	12.5×25	400	16×25	465	16×35.5	500	18×20	350	18×25	380	18×25	380	
120	16×25	510	16×20	430	18×20	465	18×25	460	16×35.5	500	18×31.5	505	18×35.5	540	
150	18×20	510	16×25	510	16×31.5	560	18×31.5	560	18×35.5	648	18×40	688	18×40	688	
180	16×25	570	16×31.5	625	16×35.5	655	18×35.5	648	18×40	688	—	—	—	—	
220	18×20	570	18×25	615	18×25	615	—	—	—	—	—	—	—	—	
330	18×25	675	16×31.5	685	18×31.5	735	18×40	750	—	—	—	—	—	—	
470	18×25	745	18×25	675	16×35.5	790	18×35.5	855	—	—	—	—	—	—	
—	—	—	18×31.5	810	—	—	—	—	—	—	—	—	—	—	
—	—	—	18×40	1090	—	—	—	—	—	—	—	—	—	—	
—	18×40	1300	—	—	—	—	—	—	—	—	—	—	—	—	

(Note) Rated ripple current : 105°C , 120Hz

105°C Miniature Capacitors

GREEN CAP **105°C** 2000hours **Anti-cleaning solvent** 250V Max.

- Case size is one rank smaller than Series RJ3.
- Guarantees 2000 hours at 105°C. (φ5 to φ8 : 1000 hours)

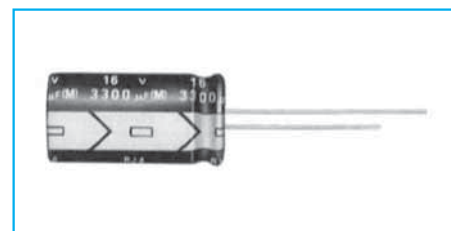
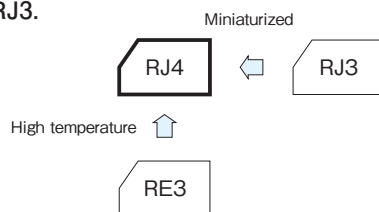

Marking color : White print on a black sleeve

Specifications

Item	Performance																																					
Category temperature range (°C)	-55 to +105	-40 to +105																																				
Rated voltage (V)	6.3 to 100	160 to 450																																				
Tolerance at rated capacitance (%)	±20 (20°C, 120Hz)	±20 (20°C, 120Hz)																																				
Leakage current (µA)	Less than 0.03CV or 4 whichever is larger (after 1 minute) Less than 0.01CV or 3 whichever is larger (after 2 minutes) (20°C)	CV ≤ 1000 : Less than 0.1CV + 40 (after 1 minute) CV > 1000 : Less than 0.04CV + 100 (after 1 minute) (20°C)																																				
Tangent of loss angle (tanδ)	C: Rated capacitance (µF) V: Rated voltage (V)																																					
	<table border="1"> <tr> <th>Rated voltage (V)</th> <td>6.3</td><td>10</td><td>16</td><td>25</td><td>35</td><td>50</td><td>63</td><td>100</td> </tr> <tr> <th>tanδ (max.)</th> <td>0.28</td><td>0.24</td><td>0.20</td><td>0.16</td><td>0.14</td><td>0.12</td><td>0.10</td><td>0.08</td> </tr> </table>	Rated voltage (V)	6.3	10	16	25	35	50	63	100	tanδ (max.)	0.28	0.24	0.20	0.16	0.14	0.12	0.10	0.08	<table border="1"> <tr> <th>Rated voltage (V)</th> <td>160</td><td>200</td><td>250</td><td>315</td><td>350</td><td>400</td><td>450</td> </tr> <tr> <th>tanδ (max.)</th> <td>0.20</td><td>0.20</td><td>0.20</td><td>0.24</td><td>0.24</td><td>0.24</td><td>0.24</td> </tr> </table>	Rated voltage (V)	160	200	250	315	350	400	450	tanδ (max.)	0.20	0.20	0.20	0.24	0.24	0.24	0.24		
	Rated voltage (V)	6.3	10	16	25	35	50	63	100																													
tanδ (max.)	0.28	0.24	0.20	0.16	0.14	0.12	0.10	0.08																														
Rated voltage (V)	160	200	250	315	350	400	450																															
tanδ (max.)	0.20	0.20	0.20	0.24	0.24	0.24	0.24																															
0.02 is added to every 1000µF increase over 1000µF (20°C, 120Hz)		(20°C, 120Hz)																																				
Characteristics at high and low temperature	<table border="1"> <tr> <th>Rated voltage (V)</th> <td>6.3</td><td>10</td><td>16</td><td>25</td><td>35</td><td>50</td><td>63</td><td>100</td> </tr> <tr> <th rowspan="2">Impedance ratio (max.)</th> <td>Z-25°C/Z+20°C</td> <td>5</td><td>4</td><td>3</td><td>2</td><td>2</td><td>2</td><td>2</td> </tr> <tr> <td>Z-40°C/Z+20°C</td> <td>10</td><td>8</td><td>6</td><td>4</td><td>3</td><td>3</td><td>3</td> </tr> </table>	Rated voltage (V)	6.3	10	16	25	35	50	63	100	Impedance ratio (max.)	Z-25°C/Z+20°C	5	4	3	2	2	2	2	Z-40°C/Z+20°C	10	8	6	4	3	3	3	<table border="1"> <tr> <th>Rated voltage (V)</th> <td>160 to 250</td><td>315 to 450</td> </tr> <tr> <th rowspan="2">Impedance ratio (max.)</th> <td>Z-25°C/Z+20°C</td> <td>4</td><td>4</td> </tr> <tr> <td>Z-40°C/Z+20°C</td> <td>15</td><td>10</td> </tr> </table>	Rated voltage (V)	160 to 250	315 to 450	Impedance ratio (max.)	Z-25°C/Z+20°C	4	4	Z-40°C/Z+20°C	15	10
	Rated voltage (V)	6.3	10	16	25	35	50	63	100																													
Impedance ratio (max.)	Z-25°C/Z+20°C	5	4	3	2	2	2	2																														
	Z-40°C/Z+20°C	10	8	6	4	3	3	3																														
Rated voltage (V)	160 to 250	315 to 450																																				
Impedance ratio (max.)	Z-25°C/Z+20°C	4	4																																			
	Z-40°C/Z+20°C	15	10																																			
		(120Hz)																																				
Endurance (105°C) (Applied ripple current)	Test time	2000 hours (φ5 to φ8 : 1000 hours)																																				
	Leakage current	The initial specified value or less																																				
	Percentage of capacitance change	Within ±20% of initial value																																				
	Tangent of the loss angle	200% or less of the initial specified value																																				
Shelf life (105°C)	Test time : 1000 hours ; other items are the same as those for the endurance. Voltage application treatment																																					
Applicable standards	JIS C5101-1, -4 1998 (IEC 60384-1 1992, -4 1985)																																					

Outline Drawing

Unit : mm

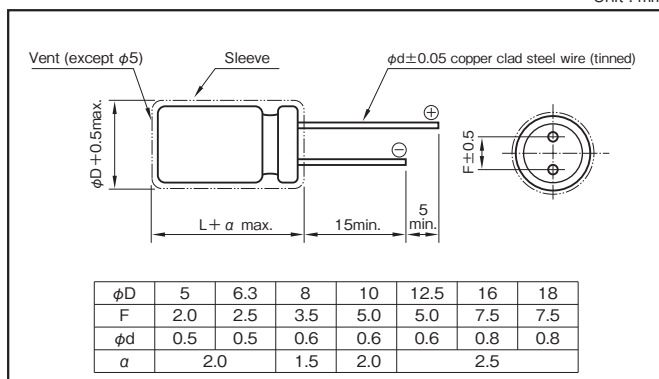

Coefficient of Frequency for Rated Ripple Current

Rated voltage (V)	Rated capacitance (µF)	Frequency (Hz)					
		50 · 60	120	1k	10k	100k	
6.3 to 100	0.1 to 47	0.8	1	1.5	1.7	2.0	
	100 to 220	0.8	1	1.2	1.3	1.4	
	330 to 1000	0.8	1	1.2	1.2	1.3	
	2200 to 22000	0.8	1	1.1	1.1	1.1	
160 to 450	0.47 to 330	0.8	1	1.3	1.4	1.6	

Part numbering system (example : 16V2200µF)

RJ4	—	16	V	222	M	I5	#	□	—	□
Series code		Rated voltage symbol		Rated capacitance symbol	Capacitance tolerance symbol	Casing symbol	Optional symbol			Taping/Forming symbol

Casing symbol

Size φD×L (mm)	Casing Symbol	Size φD×L (mm)	Casing Symbol
5×11	E3	12.5×25	I6
6.3×11	F3	16×25	J6
8×11.5	G3	16×31.5	J7
10×12.5	H3	16×35.5	J8
10×16	H4	18×31.5	K7
10×20	H5	18×35.5	K8
12.5×20	I5	18×40	K9

NOTE

Design, Specifications are subject to change without notice. Ask factory for technical specifications before purchase and/or use.

Standard Ratings

Rated capacitance (μF)	6.3			10			16			25			35			50			63			100		
	Item			Item			Item			Item			Item			Item			Item			Item		
	Case	ESR	Rated ripple current	Case	ESR	Rated ripple current	Case	ESR	Rated ripple current	Case	ESR	Rated ripple current	Case	ESR	Rated ripple current	Case	ESR	Rated ripple current	Case	ESR	Rated ripple current	Case	ESR	Rated ripple current
	φD×L (mm)	(Ω)	(mA rms)	φD×L (mm)	(Ω)	(mA rms)	φD×L (mm)	(Ω)	(mA rms)	φD×L (mm)	(Ω)	(mA rms)	φD×L (mm)	(Ω)	(mA rms)	φD×L (mm)	(Ω)	(mA rms)	φD×L (mm)	(Ω)	(mA rms)	φD×L (mm)	(Ω)	(mA rms)
1	—	—	—	—	—	—	—	—	—	—	—	—	—	—	5×11	199	15	—	—	—	5×11	133	15	
2.2	—	—	—	—	—	—	—	—	—	—	—	—	—	—	5×11	90.5	22	—	—	—	5×11	60.3	21	
3.3	—	—	—	—	—	—	—	—	—	—	—	—	—	—	5×11	60.3	27	—	—	—	5×11	40.2	29	
4.7	—	—	—	—	—	—	—	—	—	5×11	56.5	27	5×11	49.4	30	5×11	42.4	32	—	—	—	5×11	28.2	32
10	—	—	—	—	—	—	5×11	33.2	37	5×11	26.5	39	5×11	23.2	43	5×11	19.9	47	5×11	16.6	46	6.3×11	13.3	54
22	—	—	—	—	—	—	5×11	15.1	54	5×11	12.1	58	5×11	10.6	64	5×11	9.05	70	5×11	7.54	71	6.3×11	6.03	93
33	—	—	—	—	—	—	5×11	10.1	67	5×11	8.04	71	5×11	7.04	78	5×11	6.03	90	6.3×11	5.03	100	8×11.5	4.02	130
47	—	—	—	5×11	8.47	72	5×11	7.06	79	5×11	5.65	84	5×11	4.94	90	6.3×11	4.24	115	6.3×11	3.53	120	10×12.5	2.82	165
100	—	—	—	5×11	3.98	105	5×11	3.32	115	6.3×11	2.65	141	6.3×11	2.32	151	8×11.5	1.99	190	10×12.5	1.66	215	10×20	1.33	265
220	5×11	2.11	140	6.3×11	1.81	166	6.3×11	1.51	190	8×11.5	1.21	247	10×12.5	1.06	314	10×12.5	0.91	314	10×16	0.75	335	12.5×25	0.60	440
330	6.3×11	1.41	195	6.3×11	1.21	210	8×11.5	1.01	271	10×12.5	0.81	360	10×12.5	0.70	384	10×16	0.60	421	10×20	0.50	510	12.5×25	0.40	540
470	6.3×11	0.99	232	8×11.5	0.85	325	8×11.5	0.71	323	10×12.5	0.57	429	10×16	0.50	470	12.5×20	0.42	628	12.5×20	0.35	640	16×25	0.28	715
1000	8×11.5	0.47	398	10×12.5	0.40	457	10×16	0.33	560	10×20	0.27	705	12.5×20	0.23	857	12.5×25	0.20	1000	16×25	0.17	930	18×40	0.13	985
2200	10×20	0.23	720	10×20	0.20	761	12.5×20	0.17	961	12.5×25	0.14	1180	16×25	0.12	1380	16×35.5	0.11	1660	—	—	—	—	—	—
3300	10×20	0.16	882	12.5×20	0.14	1010	12.5×25	0.12	1200	16×25	0.10	1440	16×35.5	0.09	1780	18×35.5	0.08	1990	—	—	—	—	—	—
4700	12.5×20	0.12	1120	12.5×25	0.11	1250	16×25	0.09	1490	16×31.5	0.08	1880	18×35.5	0.07	2120	—	—	—	—	—	—	—	—	—
6800	12.5×25	0.09	1380	16×25	0.08	1570	16×35.5	0.07	1830	18×35.5	0.06	2330	—	—	—	—	—	—	—	—	—	—	—	—
10000	16×25	0.07	1750	16×35.5	0.07	1910	18×35.5	0.06	2220	—	—	—	—	—	—	—	—	—	—	—	—	—	—	—
15000	16×35.5	0.06	2040	18×35.5	0.06	2190	—	—	—	—	—	—	—	—	—	—	—	—	—	—	—	—	—	—
22000	18×40	0.05	2390	—	—	—	—	—	—	—	—	—	—	—	—	—	—	—	—	—	—	—	—	—

Rated capacitance (μF)	160			200			250			315			350			400			450				
	Item			Item			Item			Item			Item			Item			Item				
	Case	ESR	Rated ripple current	Case	ESR	Rated ripple current	Case	ESR	Rated ripple current	Case	ESR	Rated ripple current	Case	ESR	Rated ripple current	Case	ESR	Rated ripple current	Case	ESR	Rated ripple current		
	φD×L (mm)	(Ω)	(mA rms)	φD×L (mm)	(Ω)	(mA rms)	φD×L (mm)	(Ω)	(mA rms)	φD×L (mm)	(Ω)	(mA rms)	φD×L (mm)	(Ω)	(mA rms)	φD×L (mm)	(Ω)	(mA rms)	φD×L (mm)	(Ω)	(mA rms)		
0.47	6.3×11	706	11	6.3×11	706	11	6.3×11	706	11	6.3×11	847	11	6.3×11	847	11	6.3×11	847	11	8×11.5	847	13		
1	6.3×11	332	16	6.3×11	332	16	6.3×11	332	16	6.3×11	398	16	6.3×11	398	16	6.3×11	398	16	8×11.5	398	18		
2.2	6.3×11	151	23	6.3×11	151	23	6.3×11	151	23	8×11.5	181	27	8×11.5	181	27	8×11.5	181	27	10×12.5	181	31		
3.3	6.3×11	101	28	6.3×11	101	28	8×11.5	101	34	10×12.5	121	38	10×12.5	121	38	10×12.5	121	38	10×16	121	42		
4.7	6.3×11	70.6	34	8×11.5	70.6	40	8×11.5	70.6	40	10×12.5	84.7	45	10×12.5	84.7	45	10×16	84.7	50	10×20	84.7	54		
10	8×11.5	33.2	58	10×12.5	33.2	66	10×16	33.2	74	10×20	39.8	79	10×20	39.8	79	12.5×20	39.8	87	12.5×20	39.8	87		
22	10×16	15.1	107	10×20	15.1	120	12.5×20	15.1	130	12.5×20	18.1	129	12.5×25	18.1	140	12.5×25	18.1	140	16×25	18.1	160		
33	10×20	10.1	143	12.5×20	10.1	160	12.5×25	10.1	172	16×25	12.1	196	16×25	12.1	196	16×25	12.1	196	16×31.5	12.1	215		
47	12.5×20	7.06	188	12.5×20	7.06	188	12.5×25	7.06	205	16×25	8.47	234	16×25	8.47	234	16×31.5	8.47	256	16×35.5	8.47	269		
100	12.5×25	3.32	299	16×25	3.32	342	16×31.5	3.32	374	18×31.5	3.98	401	18×31.5	3.98	401	—	—	—	—	—	—	—	—
220	16×31.5	1.51	554	18×35.5	1.51	624	—	—	—	—	—	—	—	—	—	—	—	—	—	—	—	—	—
330	18×35.5	1.01	764	—	—	—	—	—	—	—	—	—	—	—	—	—	—	—	—	—	—	—	—

(Note) ESR : 20°C, 120Hz ; Rated ripple current : 105°C, 120Hz

105°C Use, Standard Capacitors

GREEN CAP 105°C 2000hours Anti-cleaning solvent 250V Max.

• Guarantees 2000 hours at 105°C (φ5~8 : 1000 hours).

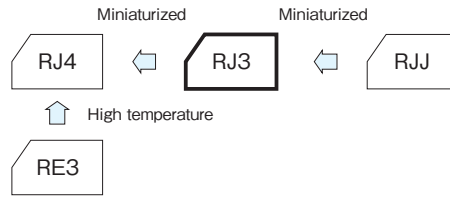

Marking color : White print on a black sleeve

Specifications

Item	Performance																																			
Category temperature range (°C)	-55 to +105	-40 to +105																																		
Rated voltage (V)	6.3 to 100	160 to 450																																		
Tolerance at rated capacitance (%)	±20 (20°C, 120Hz)	±20 (20°C, 120Hz)																																		
Leakage current (µA)	Less than 0.01CV or 3 whichever is larger (after 2 minutes) (20°C) C : Rated capacitance (µF) V : Rated voltage (V)																																			
Tangent of loss angle (tanδ)	<table border="1"> <tr> <th>Rated voltage (V)</th> <td>6.3</td><td>10</td><td>16</td><td>25</td><td>35</td><td>50</td><td>63</td><td>100</td> </tr> <tr> <th>tanδ (max.)</th> <td>0.22</td><td>0.19</td><td>0.16</td><td>0.14</td><td>0.12</td><td>0.10</td><td>0.09</td><td>0.08</td> </tr> </table> <p>0.02 is added to every 1000µF increase over 1000µF (20°C, 120Hz)</p>	Rated voltage (V)	6.3	10	16	25	35	50	63	100	tanδ (max.)	0.22	0.19	0.16	0.14	0.12	0.10	0.09	0.08	<table border="1"> <tr> <th>Rated voltage (V)</th> <td>160</td><td>200</td><td>250</td><td>315</td><td>350</td><td>400</td> </tr> <tr> <th>tanδ (max.)</th> <td>0.15</td><td>0.15</td><td>0.15</td><td>0.20</td><td>0.20</td><td>0.20</td> </tr> </table> <p>(20°C, 120Hz)</p>	Rated voltage (V)	160	200	250	315	350	400	tanδ (max.)	0.15	0.15	0.15	0.20	0.20	0.20		
	Rated voltage (V)	6.3	10	16	25	35	50	63	100																											
tanδ (max.)	0.22	0.19	0.16	0.14	0.12	0.10	0.09	0.08																												
Rated voltage (V)	160	200	250	315	350	400																														
tanδ (max.)	0.15	0.15	0.15	0.20	0.20	0.20																														
Characteristics at high and low temperature	<table border="1"> <tr> <th>Rated voltage (V)</th> <td>6.3</td><td>10</td><td>16</td><td>25</td><td>35</td><td>50</td><td>63</td><td>100</td> </tr> <tr> <th rowspan="2">Impedance ratio (max.)</th> <td>Z-25°C/Z+20°C</td> <td>5</td><td>4</td><td>3</td><td>2</td><td>2</td><td>2</td><td>2</td> </tr> <tr> <td>Z-55°C/Z+20°C</td> <td>10</td><td>8</td><td>6</td><td>4</td><td>3</td><td>3</td><td>3</td> </tr> </table> <p>(120Hz)</p>	Rated voltage (V)	6.3	10	16	25	35	50	63	100	Impedance ratio (max.)	Z-25°C/Z+20°C	5	4	3	2	2	2	2	Z-55°C/Z+20°C	10	8	6	4	3	3	3	<table border="1"> <tr> <th>Rated voltage (V)</th> <td>160 to 250</td><td>315 to 400</td> </tr> <tr> <th rowspan="2">Impedance ratio (max.)</th> <td>Z-25°C/Z+20°C</td> <td>3</td> </tr> <tr> <td>Z-40°C/Z+20°C</td> <td>8</td> </tr> </table> <p>(120Hz)</p>	Rated voltage (V)	160 to 250	315 to 400	Impedance ratio (max.)	Z-25°C/Z+20°C	3	Z-40°C/Z+20°C	8
	Rated voltage (V)	6.3	10	16	25	35	50	63	100																											
Impedance ratio (max.)	Z-25°C/Z+20°C	5	4	3	2	2	2	2																												
	Z-55°C/Z+20°C	10	8	6	4	3	3	3																												
Rated voltage (V)	160 to 250	315 to 400																																		
Impedance ratio (max.)	Z-25°C/Z+20°C	3																																		
	Z-40°C/Z+20°C	8																																		
Endurance (105°C) (Applied ripple current)	Test time	2000 hours (φ5 to φ8 : 1000 hours)																																		
	Leakage current	The initial specified value or less																																		
	Percentage of capacitance change	Within ±20% of initial value																																		
	Tangent of the loss angle	200% or less of the initial specified value																																		
Shelf life (105°C)	Test time : 1000 hours; other items are the same as those for the endurance. Voltage application treatment																																			
Applicable standards	JIS C5101-1, -4 1998 (IEC 60384-1 1992, -4 1985)																																			

Outline Drawing

Unit : mm

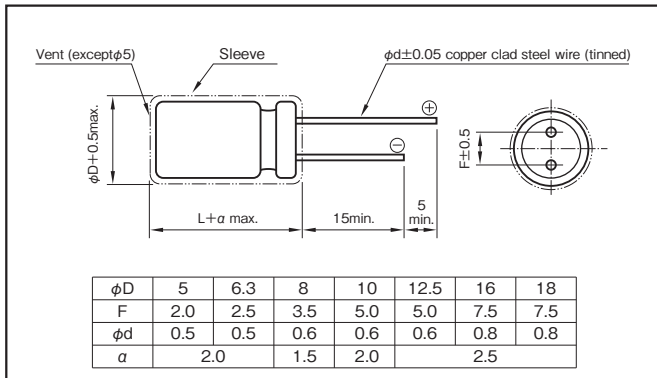

Coefficient of Frequency for Rated Ripple Current

Rated voltage (V)	Rated capacitance (µF)	Frequency (Hz)				
		50 · 60	120	1k	10k	100k
6.3 to 100	0.1 to 4.7	—	0.4	0.7	0.8	1
	10 to 47	—	0.5	0.8	0.9	1
	100 to 220	—	0.7	0.9	0.9	1
	330 to 1000	—	0.8	0.9	1.0	1
	2200 to 15000	—	0.9	1.0	1	1
160 to 400	0.47 to 220	0.8	1	1.3	1.4	1.6

Part numbering system (example : 63V1000µF)

RJ3	—	63	V	102	M	J7	#	□	—	□
Series code		Rated voltage symbol		Rated capacitance symbol	Capacitance tolerance symbol	Casing symbol	Optional symbol			Taping/Forming symbol

Casing symbol

Size φD×L (mm)	Casing Symbol	Size φD×L (mm)	Casing Symbol
5×11	E3	12.5×25	I6
6.3×11	F3	16×25	J6
8×11.5	G3	16×31.5	J7
10×12.5	H3	16×35.5	J8
10×16	H4	18×35.5	K8
10×20	H5	18×40	K9
12.5×20	I5		

NOTE

Design, Specifications are subject to change without notice. Ask factory for technical specifications before purchase and/or use.

Standard Ratings

Rated voltage (V)	Item	6.3				10				16				25			
		Case	ESR	Impedance	Rated ripple current	Case	ESR	Impedance	Rated ripple current	Case	ESR	Impedance	Rated ripple current	Case	ESR	Impedance	Rated ripple current
		φD×L (mm)	(Ω)	(Ω max.)	(mA _{rms})	φD×L (mm)	(Ω)	(Ω max.)	(mA _{rms})	φD×L (mm)	(Ω)	(Ω max.)	(mA _{rms})	φD×L (mm)	(Ω)	(Ω max.)	(mA _{rms})
4.7	—	—	—	—	—	—	—	—	—	—	—	—	—	—	—	—	—
10	—	—	—	—	—	—	—	—	—	5×11	26.5	2.5	92	5×11	23.2	2.5	92
22	—	—	—	—	5×11	14.3	2.5	92	5×11	12.1	1.9	105	5×11	10.6	1.9	105	
33	5×11	11.1	2.5	105	5×11	9.55	1.9	105	5×11	8.04	1.5	120	5×11	7.04	1.5	120	
47	5×11	7.77	1.5	120	5×11	6.71	1.5	120	5×11	5.65	1.2	130	5×11	4.94	1.2	130	
100	5×11	3.65	1.2	130	5×11	3.15	1.2	130	6.3×11	2.65	0.58	220	6.3×11	2.32	0.58	220	
220	6.3×11	1.66	0.87	180	6.3×11	1.43	0.58	220	8×11.5	1.21	0.47	290	8×11.5	1.06	0.39	315	
330	6.3×11	1.11	0.58	220	8×11.5	0.96	0.47	265	8×11.5	0.81	0.39	315	10×12.5	0.70	0.23	500	
470	8×11.5	0.78	0.39	315	8×11.5	0.67	0.39	315	10×12.5	0.57	0.23	500	10×16	0.50	0.18	615	
1000	10×12.5	0.37	0.23	500	10×16	0.32	0.18	615	10×20	0.27	0.12	825	12.5×20	0.23	0.090	1050	
2200	12.5×20	0.18	0.095	1000	12.5×20	0.16	0.090	1050	12.5×25	0.14	0.068	1300	16×25	0.12	0.056	1740	
3300	12.5×20	0.13	0.090	1050	12.5×25	0.12	0.068	1300	16×25	0.10	0.056	1740	16×31.5	0.09	0.045	2110	
4700	16×25	0.10	0.061	1670	16×25	0.09	0.056	1740	16×31.5	0.08	0.045	2110	18×35.5	0.07	0.036	2580	
6800	16×25	0.08	0.056	1740	16×31.5	0.07	0.045	2110	18×35.5	0.06	0.036	2580	—	—	—	—	
10000	16×31.5	0.06	0.045	2110	18×35.5	0.06	0.036	2580	—	—	—	—	—	—	—	—	
15000	18×35.5	0.05	0.036	2580	—	—	—	—	—	—	—	—	—	—	—	—	

Rated voltage (V)	Item	35				50				63				100			
		Case	ESR	Impedance	Rated ripple current	Case	ESR	Impedance	Rated ripple current	Case	ESR	Impedance	Rated ripple current	Case	ESR	Impedance	Rated ripple current
		φD×L (mm)	(Ω)	(Ω max.)	(mA _{rms})	φD×L (mm)	(Ω)	(Ω max.)	(mA _{rms})	φD×L (mm)	(Ω)	(Ω max.)	(mA _{rms})	φD×L (mm)	(Ω)	(Ω max.)	(mA _{rms})
1	—	—	—	—	5×11	166	4.9	35	—	—	—	—	5×11	133	11	45	
2.2	—	—	—	—	5×11	75.4	4.2	53	—	—	—	—	5×11	60.3	9.2	60	
3.3	—	—	—	—	5×11	50.3	3.9	65	—	—	—	—	5×11	40.2	7.2	67	
4.7	5×11	42.4	2.5	92	5×11	35.3	3.6	82	5×11	31.8	5.8	74	5×11	28.2	6.3	75	
10	5×11	19.9	1.9	105	5×11	16.6	2.7	100	5×11	14.9	3.6	95	6.3×11	13.3	3.3	110	
22	5×11	9.05	1.5	120	5×11	7.54	1.9	125	6.3×11	6.79	2.1	130	8×11.5	6.03	1.4	165	
33	5×11	6.03	1.2	130	6.3×11	5.03	1.1	195	6.3×11	4.52	1.7	160	10×12.5	4.02	0.94	305	
47	6.3×11	4.24	0.58	220	6.3×11	3.53	0.90	245	8×11.5	3.18	1.2	305	10×16	2.82	0.68	320	
100	8×11.5	1.99	0.39	315	8×11.5	1.66	0.50	385	10×12.5	1.49	0.65	395	12.5×20	1.33	0.28	585	
220	10×12.5	0.91	0.23	500	10×16	0.75	0.27	505	10×20	0.68	0.32	505	16×25	0.60	0.16	1120	
330	10×16	0.60	0.18	615	10×20	0.50	0.18	675	12.5×20	0.45	0.22	660	16×25	0.40	0.13	1290	
470	10×20	0.42	0.12	825	12.5×20	0.35	0.12	895	12.5×25	0.32	0.16	850	16×31.5	0.28	0.11	1350	
1000	12.5×25	0.20	0.068	1300	16×25	0.17	0.076	1495	16×31.5	0.15	0.098	1430	—	—	—	—	
2200	16×31.5	0.11	0.045	2110	18×35.5	0.09	0.050	2190	—	—	—	—	—	—	—	—	
3300	18×35.5	0.08	0.036	2580	—	—	—	—	—	—	—	—	—	—	—	—	

(Note) ESR : 20°C, 120Hz ; Impedance : 20°C, 100kHz ; Rated ripple current : 105°C, 100kHz

Rated voltage (V)	Item	160			200			250			315			350			400		
		Case	ESR	Rated ripple current	Case	ESR	Rated ripple current	Case	ESR	Rated ripple current	Case	ESR	Rated ripple current	Case	ESR	Rated ripple current	Case	ESR	Rated ripple current
		φD×L (mm)	(Ω)	(mA _{rms})	φD×L (mm)	(Ω)	(mA _{rms})	φD×L (mm)	(Ω)	(mA _{rms})	φD×L (mm)	(Ω)	(mA _{rms})	φD×L (mm)	(Ω)	(mA _{rms})	φD×L (mm)	(Ω)	(mA _{rms})
0.47	6.3×11	529	12	6.3×11	529	12	6.3×11	529	12	6.3×11	705	11	6.3×11	705	11	—	—	—	
1	6.3×11	248	18	6.3×11	248	18	6.3×11	248	18	6.3×11	331	16	6.3×11	331	18	8×11.5	331	18	
2.2	6.3×11	113	26	6.3×11	113	26	8×11.5	113	30	8×11.5	150	27	8×11.5	150	30	10×12.5	150	30	
3.3	8×11.5	75.4	37	8×11.5	75.4	37	10×12.5	75.4	43	10×12.5	100	36	10×12.5	100	36	10×16	100	40	
4.7	8×11.5	52.9	44	10×12.5	52.9	50	10×12.5	52.9	50	10×16	70.6	47	10×16	70.6	47	10×20	70.6	52	
10	10×12.5	24.9	75	10×16	24.9	80	10×20	24.9	90	10×20	33.2	75	12.5×20	33.2	79	12.5×20	33.2	79	
22	10×20	11.3	135	10×20	11.3	135	12.5×25	11.3	155	12.5×25	15.1	130	12.5×25	15.1	130	16×25	15.1	130	
33	12.5×20	7.54	175	12.5×25	7.54	190	12.5×25	7.54	190	16×25	10.1	160	16×25	10.1	160	16×31.5	10.1	175	
47	12.5×25	5.29	230	12.5×25	5.29	230	16×25	5.29	225	16×31.5	7.06	210	16×31.5	7.06	210	18×35.5	7.06	220	
100	16×25	2.49	330	16×31.5	2.49	360	18×35.5	2.49	340	18×40	3.32	335	18×40	3.32	335	—	—	—	
220	18×35.5	1.13	500	18×40	1.13	525	—	—	—	—	—	—	—	—	—	—	—	—	

(Note) ESR : 20°C, 120Hz ; Rated ripple current : 105°C, 120Hz

NOTE

Design, Specifications are subject to change without notice.
Ask factory for technical specifications before purchase and/or use.

105°C Use, Miniature, High-Reliability, Low Impedance Capacitors

GREEN CAP Low Impedance 105°C 5000hours Anti-cleaning solvent

- Smaller and higher ripple current than RJH Series.
- Guarantees 5000 hours at 105°C.
(ϕ 5 to 6.3 : 2000 hours ; ϕ 8 to 10 : 3000 hours)

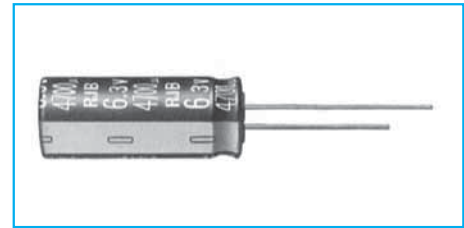

Marking color : White print on a black sleeve

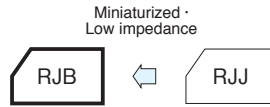

Specifications

Item	Performance								
Category temperature range (°C)	-55 to +105								
Tolerance at rated capacitance (%)	±20 (20°C, 120Hz)								
Leakage current (µA)	Less than 0.01CV + 2 (after 2 minutes) C : Rated capacitance (µF) ; V : Rated voltage (V) (20°C)								
Tangent of loss angle (tanδ)	Rated voltage (V)	6.3	10	16	25	35	50	63	100
	tanδ (max.)	0.22	0.19	0.16	0.14	0.12	0.10	0.08	0.07
0.02 is added to every 1000µF increase over 1000µF. (20°C, 120Hz)									
Characteristics at high and low temperature	Rated voltage (V)	6.3	10	16	25	35	50	63	100
	Impedance ratio (max.)	Z-55°C/Z+20°C	3	3	3	3	3	3	3
(120Hz)									
Endurance (105°C) (Applied ripple current)	Test time	5000 hours (ϕ 5 to 6.3 : 2000 hours) (ϕ 8 to 10 : 3000 hours)							
	Leakage current	The initial specified value or less							
	Percentage of capacitance change	Within ±20% of initial value							
	Tangent of the loss angle	200% or less of the initial specified value							
Shelf life (105°C)	Test time	1000 hours							
	Leakage current	The initial specified value or less							
	Percentage of capacitance change	Within ±15% of initial value							
	Tangent of the loss angle	150% or less of the initial specified value							
Voltage application treatment									
Applicable standards	JIS C5101-1, -4 1998 (IEC 60384-1 1992, -4 1985)								

Outline Drawing

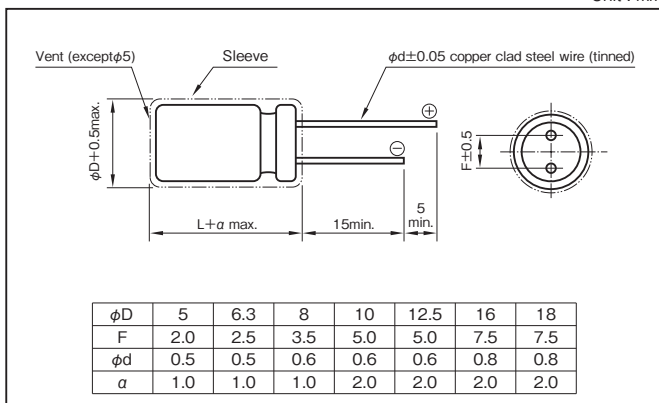

Coefficient of Frequency for Rated Ripple Current

Rated capacitance (µF)	Frequency (Hz)			
	120	1k	10k	100k
0.47 to 180	0.40	0.75	0.90	1
220 to 390	0.50	0.85	0.95	1
470 to 1800	0.60	0.88	0.96	1
2200 to 3900	0.75	0.90	0.98	1
4700 to 10000	0.85	0.95	1	1

Part numbering system (example : 10V1000µF)

RJB	—	10	V	102	M	H4	#	—	□
Series code		Rated voltage symbol		Rated capacitance symbol	Capacitance tolerance symbol	Casing symbol			Taping(Forming) symbol

• The electric characteristics are described on page 172.

Standard Ratings

Rated voltage (V) Rated capacitance (μF)	Item	6.3					10					16				
		Case φD×L (mm)	Casing symbol	Impedance (Ω max.)		Rated ripple current (mAmps)	Case φD×L (mm)	Casing symbol	Impedance (Ω max.)		Rated ripple current (mAmps)	Case φD×L (mm)	Casing symbol	Impedance (Ω max.)		Rated ripple current (mAmps)
				20°C	-10°C				20°C	-10°C				20°C	-10°C	
100	—	—	—	—	—	5×11.5	E3	0.65	1.3	181	—	—	—	—	—	
220	—	—	—	—	—	6.3×11.5	F3	0.32	0.64	290	—	—	—	—	—	
330	6.3×11.5	F3	0.32	0.64	290	8×12	G3	0.17	0.34	555	8×12	G3	0.17	0.34	555	
470	8×12	G3	0.17	0.34	555	8×12	G3	0.17	0.34	555	10×12.5	H3	0.12	0.24	760	
680	8×12	G3	0.17	0.34	555	10×12.5	H3	0.12	0.24	760	10×16	H4	0.080	0.16	1050	
1000	10×12.5	H3	0.12	0.24	760	10×16	H4	0.080	0.16	1050	10×20	H5	0.062	0.124	1220	
2200	10×25	H6	0.052	0.104	1440	12.5×20	I5	0.042	0.084	1690	12.5×25	I6	0.034	0.068	1950	
3300	12.5×20	I5	0.042	0.084	1690	12.5×25	I6	0.034	0.068	1950	16×25	J6	0.028	0.056	2560	
4700	12.5×30	I7	0.030	0.060	2310	16×25	J6	0.028	0.056	2560	16×31.5	J7	0.025	0.050	3010	
6800	16×25	J6	0.028	0.056	2560	16×31.5	J7	0.025	0.050	3010	—	—	—	—	—	
10000	16×31.5	J7	0.025	0.050	3010	—	—	—	—	—	—	—	—	—	—	

Rated voltage (V) Rated capacitance (μF)	Item	25					35					50				
		Case φD×L (mm)	Casing symbol	Impedance (Ω max.)		Rated ripple current (mAmps)	Case φD×L (mm)	Casing symbol	Impedance (Ω max.)		Rated ripple current (mAmps)	Case φD×L (mm)	Casing symbol	Impedance (Ω max.)		Rated ripple current (mAmps)
				20°C	-10°C				20°C	-10°C				20°C	-10°C	
22	—	—	—	—	—	—	—	—	—	—	5×11.5	E3	0.95	1.9	170	
33	—	—	—	—	—	5×11.5	E3	0.65	1.3	181	6.3×11.5	F3	0.46	0.92	260	
47	5×11.5	E3	0.65	1.3	181	6.3×11.5	F3	0.32	0.64	290	6.3×11.5	F3	0.46	0.92	260	
100	6.3×11.5	F3	0.32	0.64	290	8×12	G3	0.17	0.34	555	8×12	G3	0.21	0.42	485	
150	—	—	—	—	—	—	—	—	—	—	10×12.5	H3	0.19	0.38	615	
220	8×12	G3	0.17	0.34	555	10×12.5	H3	0.12	0.24	760	10×16	H4	0.16	0.32	850	
330	10×12.5	H3	0.12	0.24	760	10×16	H4	0.080	0.16	1050	10×20	H5	0.085	0.17	1050	
470	10×16	H4	0.080	0.16	1050	10×20	H5	0.062	0.124	1220	12.5×20	I5	0.060	0.12	1500	
680	10×20	H5	0.062	0.124	1220	12.5×20	I5	0.042	0.084	1690	12.5×25	I6	0.045	0.090	1832	
1000	12.5×20	I5	0.042	0.084	1690	12.5×25	I6	0.034	0.068	1950	16×25	J6	0.038	0.076	2240	
2200	16×25	J6	0.028	0.056	2560	16×31.5	J7	0.025	0.050	3010	—	—	—	—	—	
3300	16×31.5	J7	0.025	0.050	3010	—	—	—	—	—	—	—	—	—	—	

Rated voltage (V) Rated capacitance (μF)	Item	63					100				
		Case φD×L (mm)	Casing symbol	Impedance (Ω max.)		Rated ripple current (mAmps)	Case φD×L (mm)	Casing symbol	Impedance (Ω max.)		Rated ripple current (mAmps)
				20°C	-10°C				20°C	-10°C	
3.3	—	—	—	—	—	5×11.5	E3	1.9	7.6	57	
4.7	5×11.5	E3	1.2	3.6	120	5×11.5	E3	1.9	7.6	57	
10	5×11.5	E3	1.2	3.6	120	6.3×11.5	F3	1.1	4.4	78	
22	6.3×11.5	F3	0.55	1.7	148	8×12	G3	0.53	2.1	275	
33	6.3×11.5	F3	0.55	1.7	148	10×12.5	H3	0.47	1.9	319	
47	8×12	G3	0.32	0.96	360	10×16	H4	0.32	1.3	424	
100	10×12.5	H3	0.23	0.69	448	12.5×20	I5	0.13	0.52	805	
220	10×20	H5	0.12	0.36	676	16×25	J6	0.081	0.32	1290	
330	12.5×20	I5	0.075	0.23	979	16×25	J6	0.081	0.32	1290	
470	12.5×25	I6	0.065	0.20	1180	16×31.5	J7	0.059	0.23	1630	
1000	16×31.5	J7	0.042	0.13	1890	—	—	—	—	—	

(Note) Impedance : 100kHz ; Rated ripple current : 105°C, 100kHz

NOTE

Design, Specifications are subject to change without notice.
Ask factory for technical specifications before purchase and/or use.

105°C Use, High-Reliability, Low Impedance Capacitors

GREEN CAP

Low Impedance

105°C 5000hours

Anti-cleaning solvent

- The capacitor of this Series achieves high reliability under the environmental loading prevailing in a piece of equipment on which it is mounted.
- Guarantees 5000 hours at 105°C.
($\phi 5$ to 6.3 : 2000 hours ; $\phi 8$ to 10 : 3000 hours)

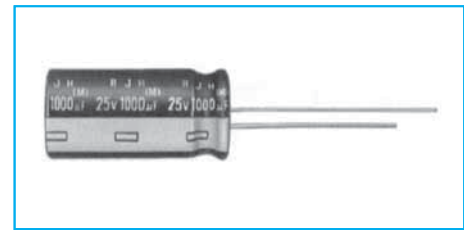
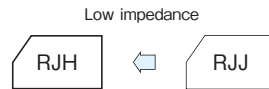

Marking color : White print on a black sleeve

Specifications

Item	Performance	
Category temperature range (°C)	-55 to +105	
Tolerance at rated capacitance (%)	±20 (20°C, 120Hz)	
Leakage current (µA)	Less than 0.01CV + 2 (after 2 minutes) C : Rated capacitance (µF) ; V : Rated voltage (V) (20°C)	
Tangent of loss angle (tanδ)	Rated voltage (V)	6.3 10 16 25 35 50 63 100
	tanδ (max.)	0.22 0.19 0.16 0.14 0.12 0.10 0.08 0.07
0.02 is added to every 1000µF increase over 1000µF. (20°C, 120Hz)		
Characteristics at high and low temperature	Rated voltage (V)	6.3 10 16 25 35 50 63 100
	Impedance ratio (max.)	Z-25°C/Z+20°C 2 2 2 2 2 2 2 2 Z-55°C/Z+20°C 3 3 3 3 3 3 3 3
(120Hz)		
Endurance (105°C) (Applied ripple current)	Test time	5000 hours ($\phi 5$ to 6.3 : 2000 hours) ($\phi 8$ to 10 : 3000 hours)
	Leakage current	The initial specified value or less
	Percentage of capacitance change	Within ±20% of initial value
	Tangent of the loss angle	200% or less of the initial specified value
Shelf life (105°C)	Test time	1000 hours
	Leakage current	The initial specified value or less
	Percentage of capacitance change	Within ±15% of initial value
	Tangent of the loss angle	150% or less of the initial specified value
Voltage application treatment		
Applicable standards	JIS C5101-1, -4 1998 (IEC 60384-1 1992, -4 1985)	

Outline Drawing

Unit : mm

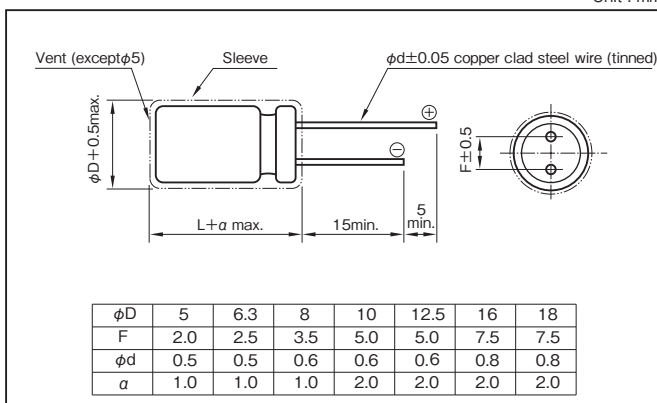

Coefficient of Frequency for Rated Ripple Current

Rated capacitance (µF) \ Frequency (Hz)	120	1k	10k	100k
0.47 to 4.7	0.40	0.68	0.78	1
5.6 to 47	0.50	0.76	0.87	1
56 to 270	0.70	0.85	0.90	1
330 to 1000	0.80	0.93	0.98	1
1200 to 15000	0.90	0.95	1	1

Part numbering system (example : 10V5600µF)

RJH	—	10	V	562	M	J7	#	—	□
Series code		Rated voltage symbol		Rated capacitance symbol	Capacitance tolerance symbol	Casing symbol			Taping(Forming) symbol

NOTE

Design, Specifications are subject to change without notice.
Ask factory for technical specifications before purchase and/or use.

Standard Ratings

Rated voltage (V)		6.3					10					
Case φD×L (mm)	Casing symbol	Item	Rated capacitance (μF)	ESR (Ω)	Impedance (Ω max.)		Rated ripple current (mA _{rms})	Rated capacitance (μF)	ESR (Ω)	Impedance (Ω max.)		Rated ripple current (mA _{rms})
					20°C	-10°C				20°C	-10°C	
5×11.5	E3		100	3.65	0.65	1.46	175	82	3.84	0.65	1.46	175
5×15	E4		150	2.43	0.46	1.04	235	100	3.15	0.46	1.04	235
6.3×11.5	F3		220	1.66	0.31	0.70	290	180	1.75	0.31	0.70	290
6.3×15	F4		330	1.11	0.20	0.45	400	220	1.43	0.20	0.45	400
8×12	G3		470	0.777	0.17	0.38	488	330	0.956	0.17	0.38	488
8×15	G4		680	0.537	0.13	0.29	617	470	0.671	0.13	0.29	617
8×20	G5		1000	0.365	0.095	0.21	800	680	0.464	0.095	0.21	800
10×12.5	H3		680	0.537	0.1	0.23	625	470	0.671	0.10	0.23	625
10×16	H4		820	0.446	0.08	0.18	825	560	0.563	0.080	0.18	825
10×20	H5		1200	0.305	0.062	0.14	1010	1000	0.316	0.062	0.14	1010
10×25	H6		1500	0.244	0.052	0.12	1190	1200	0.263	0.052	0.12	1190
10×30	H7		2200	0.181	0.044	0.099	1440	1500	0.211	0.044	0.099	1440
12.5×15	I4	•	1200	0.305	0.062	0.14	1010	• 1000	0.316	0.062	0.14	1010
12.5×20	I5		2200	0.181	0.042	0.095	1400	1800	0.176	0.042	0.095	1400
12.5×25	I6		2700	0.148	0.034	0.076	1690	2200	0.159	0.034	0.076	1690
12.5×30	I7		3900	0.111	0.03	0.068	1950	2700	0.130	0.030	0.068	1950
12.5×35	I8		4700	0.099	0.024	0.054	2220	3300	0.116	0.024	0.054	2220
12.5×40	I9		5600	0.089	0.021	0.047	2390	3900	0.098	0.021	0.047	2390
16×16	J4	•	2700	0.148	0.046	0.10	1310	• 1800	0.176	0.046	0.10	1310
16×20	J5	•	4700	0.099	0.034	0.077	1660	• 3300	0.116	0.034	0.077	1660
16×25	J6		5600	0.089	0.028	0.063	2070	3900	0.098	0.028	0.063	2070
16×31.5	J7		6800	0.079	0.025	0.056	2350	5600	0.080	0.025	0.056	2350
16×35.5	J8		8200	0.073	0.022	0.050	2550	6800	0.071	0.022	0.050	2550
16×40	J9		12000	0.059	0.018	0.041	2970	8200	0.067	0.018	0.041	2970
18×16	K4	•	3300	0.131	0.043	0.097	1460	• 2200	0.159	0.043	0.097	1460
18×20	K5	•	5600	0.089	0.030	0.068	1850	• 3900	0.098	0.030	0.068	1850
18×25	K6	•	6800	0.079	0.027	0.061	2120	• 4700	0.089	0.027	0.061	2120
18×31.5	K7		10000	0.064	0.023	0.052	2410	6800	0.071	0.023	0.052	2410
18×35.5	K8		12000	0.059	0.019	0.043	2680	8200	0.067	0.019	0.043	2680
18×40	K9		15000	0.054	0.017	0.038	3010	10000	0.059	0.017	0.038	3010

Rated voltage (V)		16					25					
Case φD×L (mm)	Casing symbol	Item	Rated capacitance (μF)	ESR (Ω)	Impedance (Ω max.)		Rated ripple current (mA _{rms})	Rated capacitance (μF)	ESR (Ω)	Impedance (Ω max.)		Rated ripple current (mA _{rms})
					20°C	-10°C				20°C	-10°C	
5×11.5	E3		56	4.74	0.65	1.46	175	39	5.96	0.65	1.46	175
5×15	E4		82	3.24	0.46	1.04	235	56	4.15	0.46	1.04	235
6.3×11.5	F3		120	2.21	0.31	0.70	290	82	2.83	0.31	0.70	290
6.3×15	F4		180	1.48	0.20	0.45	400	120	1.94	0.20	0.45	400
8×12	G3		270	0.983	0.17	0.38	488	180	1.29	0.17	0.38	488
8×15	G4		330	0.805	0.13	0.29	617	220	1.06	0.13	0.29	617
8×20	G5		470	0.565	0.095	0.21	800	330	0.704	0.095	0.21	800
10×12.5	H3		330	0.805	0.10	0.23	625	220	1.06	0.10	0.23	625
10×16	H4		390	0.681	0.080	0.18	825	270	0.861	0.080	0.18	825
10×20	H5		680	0.391	0.062	0.14	1010	470	0.495	0.062	0.14	1010
10×25	H6		820	0.324	0.052	0.12	1190	560	0.415	0.052	0.12	1190
10×30	H7		1200	0.222	0.044	0.099	1440	820	0.284	0.044	0.099	1440
12.5×15	I4	•	680	0.391	0.062	0.14	1010	• 470	0.495	0.062	0.14	1010
12.5×20	I5		1200	0.222	0.042	0.095	1400	820	0.284	0.042	0.095	1400
12.5×25	I6		1500	0.177	0.034	0.076	1690	1000	0.233	0.034	0.076	1690
12.5×30	I7		2200	0.136	0.030	0.068	1950	1500	0.155	0.030	0.068	1950
12.5×35	I8		2700	0.111	0.024	0.054	2220	1800	0.130	0.024	0.054	2220
12.5×40	I9		3300	0.101	0.021	0.047	2390	2200	0.121	0.021	0.047	2390
16×16	J4	•	1500	0.177	0.046	0.10	1310	• 820	0.284	0.046	0.10	1310
16×20	J5	•	2200	0.136	0.034	0.077	1660	• 1500	0.155	0.034	0.077	1660
16×25	J6		2700	0.111	0.028	0.063	2070	1800	0.130	0.028	0.063	2070
16×31.5	J7		3900	0.086	0.025	0.056	2350	2700	0.099	0.025	0.056	2350
16×35.5	J8		4700	0.078	0.022	0.050	2550	3300	0.091	0.022	0.050	2550
16×40	J9		5600	0.072	0.018	0.041	2970	3900	0.077	0.018	0.041	2970
18×16	K4	•	1500	0.177	0.043	0.097	1460	• 1200	0.194	0.043	0.097	1460
18×20	K5	•	2700	0.111	0.030	0.068	1850	• 1800	0.130	0.030	0.068	1850
18×25	K6	•	3900	0.086	0.027	0.061	2120	• 2700	0.099	0.027	0.061	2120
18×31.5	K7		4700	0.078	0.023	0.052	2410	3300	0.091	0.023	0.052	2410
18×35.5	K8		6800	0.064	0.019	0.043	2680	3900	0.077	0.019	0.043	2680
18×40	K9		8200	0.061	0.017	0.038	3010	4700	0.071	0.017	0.038	3010

(Note) ESR : 20°C, 120Hz ; Impedance : 100kHz ; Rated ripple current : 105°C, 100kHz
 • : The black circles in the capacitance column denote semi-standard products.

• The standard ratings follow the next page.

NOTE
 Design, Specifications are subject to change without notice.
 Ask factory for technical specifications before purchase and/or use.

Standard Ratings

Rated voltage (V)			35					50				
Case φD×L (mm)	Casing symbol	Item	Rated capacitance (μF)	ESR (Ω)	Impedance (Ω max.)		Rated ripple current (mA _{RMS})	Rated capacitance (μF)	ESR (Ω)	Impedance (Ω max.)		Rated ripple current (mA _{RMS})
					20°C	-10°C				20°C	-10°C	
5×11.5	E3	—	—	—	—	—	—	1	166	3.5	7.0	36
5×11.5	E3	—	—	—	—	—	—	2.2	75.4	3.0	6.0	54
5×11.5	E3	—	—	—	—	—	—	3.3	50.3	2.6	5.2	63
5×11.5	E3	—	—	—	—	—	—	4.7	35.3	2.2	4.4	75
5×11.5	E3	—	—	—	—	—	—	10	16.6	1.4	2.8	110
5×11.5	E3	27	7.37	0.65	1.46	175	18	9.22	0.95	1.9	1.9	120
5×15	E4	39	5.10	0.46	1.04	235	27	6.14	0.66	1.32	1.32	135
6.3×11.5	F3	56	3.56	0.31	0.70	290	39	4.25	0.43	0.86	0.86	148
6.3×15	F4	82	2.43	0.20	0.45	400	56	2.96	0.33	0.66	0.66	153
8×12	G3	120	1.66	0.17	0.38	488	68	2.44	0.20	0.40	0.40	360
8×15	G4	180	1.11	0.13	0.29	617	82	2.02	0.18	0.36	0.36	460
8×20	G5	220	0.905	0.095	0.21	800	120	1.38	0.13	0.26	0.26	670
10×12.5	H3	150	1.33	0.10	0.23	625	82	2.02	0.18	0.36	0.36	443
10×16	H4	180	1.11	0.080	0.18	825	100	1.66	0.15	0.30	0.30	553
10×20	H5	330	0.604	0.062	0.14	1010	180	0.922	0.085	0.17	0.17	676
10×25	H6	390	0.511	0.052	0.12	1190	220	0.754	0.075	0.15	0.15	876
10×30	H7	560	0.356	0.044	0.099	1440	330	0.503	0.055	0.110	0.110	1010
12.5×15	I4	• 330	0.604	0.062	0.140	1010	• 180	0.922	0.095	0.190	0.190	745
12.5×20	I5	560	0.356	0.042	0.095	1400	330	0.503	0.060	0.120	0.120	979
12.5×25	I6	680	0.293	0.034	0.076	1690	470	0.353	0.044	0.088	0.088	1180
12.5×30	I7	1000	0.200	0.030	0.068	1950	560	0.297	0.040	0.080	0.080	1310
12.5×35	I8	1200	0.166	0.024	0.054	2220	680	0.244	0.036	0.072	0.072	1470
12.5×40	I9	1500	0.133	0.021	0.047	2390	820	0.203	0.034	0.068	0.068	1590
16×16	J4	• 560	0.356	0.046	0.10	1310	• 330	0.503	0.065	0.130	0.130	982
16×20	J5	• 1000	0.200	0.034	0.077	1660	• 680	0.244	0.045	0.090	0.090	1210
16×25	J6	1200	0.166	0.028	0.063	2070	820	0.203	0.038	0.076	0.076	1490
16×31.5	J7	1800	0.111	0.025	0.056	2350	1000	0.166	0.032	0.064	0.064	1890
16×35.5	J8	2200	0.106	0.022	0.050	2550	1200	0.139	0.028	0.056	0.056	2140
16×40	J9	2700	0.087	0.018	0.041	2970	1500	0.111	0.026	0.052	0.052	2410
18×16	K4	• 680	0.293	0.043	0.097	1460	• 470	0.353	0.048	0.096	0.096	1180
18×20	K5	• 1200	0.166	0.030	0.068	1850	• 820	0.203	0.036	0.072	0.072	1450
18×25	K6	• 1800	0.111	0.027	0.061	2120	• 1000	0.166	0.032	0.064	0.064	1720
18×31.5	K7	2200	0.106	0.023	0.052	2410	1500	0.111	0.026	0.052	0.052	1970
18×35.5	K8	2700	0.087	0.019	0.043	2680	1800	0.074	0.025	0.050	0.050	2310
18×40	K9	3300	0.081	0.017	0.038	3010	2200	0.073	0.024	0.048	0.048	2530

Rated voltage (V)			63					100				
Case φD×L (mm)	Casing symbol	Item	Rated capacitance (μF)	ESR (Ω)	Impedance (Ω max.)		Rated ripple current (mA _{RMS})	Rated capacitance (μF)	ESR (Ω)	Impedance (Ω max.)		Rated ripple current (mA _{RMS})
					20°C	-10°C				20°C	-10°C	
5×11.5	E3	—	12	11.1	1.2	3.6	120	5.6	20.7	1.9	7.6	57
5×15	E4	—	18	7.37	0.85	2.6	135	8.2	14.2	1.3	5.2	74
6.3×11.5	F3	—	27	4.92	0.55	1.7	148	12	9.68	1.1	4.4	78
6.3×15	F4	—	39	3.40	0.38	1.1	153	18	6.45	0.62	2.5	85
8×12	G3	—	47	2.82	0.32	0.96	360	22	5.28	0.53	2.1	275
8×15	G4	—	68	1.95	0.24	0.72	469	33	3.52	0.35	1.4	360
8×20	G5	—	82	1.62	0.17	0.51	682	39	2.98	0.27	1.1	490
10×12.5	H3	—	56	2.37	0.23	0.69	448	27	4.30	0.47	1.9	319
10×16	H4	—	68	1.95	0.17	0.51	553	33	3.52	0.32	1.3	424
10×20	H5	—	120	1.11	0.12	0.36	676	56	2.07	0.25	0.1	499
10×25	H6	—	150	0.885	0.10	0.30	876	68	1.71	0.18	0.72	634
10×30	H7	—	180	0.738	0.085	0.26	1020	100	1.16	0.15	0.60	739
12.5×15	I4	• 150	0.885	0.11	0.33	745	• 68	1.71	0.20	0.80	0.80	613
12.5×20	I5	—	220	0.604	0.075	0.23	979	100	1.16	0.13	0.52	805
12.5×25	I6	—	270	0.492	0.065	0.20	1180	120	0.968	0.11	0.44	857
12.5×30	I7	—	390	0.341	0.055	0.17	1310	180	0.646	0.090	0.36	1120
12.5×35	I8	—	470	0.283	0.048	0.14	1470	220	0.528	0.075	0.30	1240
12.5×40	I9	—	560	0.237	0.042	0.13	1590	270	0.431	0.060	0.24	1330
16×16	J4	• 220	0.604	0.080	0.24	982	• 120	0.968	0.130	0.52	0.52	706
16×20	J5	• 390	0.341	0.057	0.17	1210	• 180	0.646	0.11	0.44	0.44	916
16×25	J6	—	470	0.283	0.052	0.16	1490	220	0.528	0.081	0.32	1290
16×31.5	J7	—	680	0.196	0.042	0.13	1890	330	0.352	0.059	0.23	1630
16×35.5	J8	—	820	0.162	0.036	0.11	2140	390	0.298	0.052	0.21	1750
16×40	J9	—	1000	0.133	0.032	0.096	2410	470	0.248	0.045	0.18	1920
18×16	K4	• 330	0.403	0.065	0.20	1200	• 150	0.775	0.12	0.48	0.48	871
18×20	K5	• 560	0.237	0.058	0.17	1460	• 270	0.431	0.085	0.34	0.34	1170
18×25	K6	• 680	0.196	0.050	0.15	1740	• 330	0.352	0.071	0.28	0.28	1500
18×31.5	K7	—	820	0.162	0.042	0.13	1990	390	0.298	0.058	0.23	1630
18×35.5	K8	—	1000	0.133	0.035	0.11	2340	560	0.208	0.054	0.22	1920
18×40	K9	—	1200	0.111	0.032	0.096	2560	680	0.171	0.041	0.16	2100

(Note) ESR : 20°C, 120Hz ; Impedance : 100kHz ; Rated ripple current : 105°C, 100kHz
 • : The black circles in the capacitance column denote semi-standard products.

105°C Use, Miniature, High-Reliability, Extra Low Impedance Capacitors

GREEN CAP Low Impedance 105°C 5000hours Anti-cleaning solvent

- Higher ripple current than RJB Series.

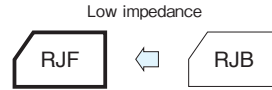

Marking color : White print on a black sleeve

Specifications

Item	Performance																													
Category temperature range (°C)	-40 to +105																													
Tolerance at rated capacitance (%)	±20 (20°C, 120Hz)																													
Leakage current (µA)	Less than 0.01CV or 3 whichever is larger (after 2 minutes) C : Rated capacitance (µF) ; V : Rated voltage (V) (20°C)																													
Tangent of loss angle (tanδ)	<table border="1"> <tr> <td>Rated voltage (V)</td> <td>6.3</td> <td>10</td> <td>16</td> <td>25</td> <td>35</td> <td>50</td> <td>63</td> <td>80</td> <td>100</td> </tr> <tr> <td>tanδ (max.)</td> <td>0.22</td> <td>0.19</td> <td>0.16</td> <td>0.14</td> <td>0.12</td> <td>0.10</td> <td>0.09</td> <td>0.09</td> <td>0.08</td> </tr> </table> <p>0.02 is added to every 1000µF increase over 1000µF. (20°C, 120Hz)</p>	Rated voltage (V)	6.3	10	16	25	35	50	63	80	100	tanδ (max.)	0.22	0.19	0.16	0.14	0.12	0.10	0.09	0.09	0.08									
Rated voltage (V)	6.3	10	16	25	35	50	63	80	100																					
tanδ (max.)	0.22	0.19	0.16	0.14	0.12	0.10	0.09	0.09	0.08																					
Characteristics at high and low temperature	<table border="1"> <tr> <td>Rated voltage (V)</td> <td>6.3</td> <td>10</td> <td>16</td> <td>25</td> <td>35</td> <td>50</td> <td>63</td> <td>80</td> <td>100</td> </tr> <tr> <td rowspan="2">Impedance ratio (max.)</td> <td>Z-25°C/Z+20°C</td> <td>2</td> <td>2</td> <td>2</td> <td>2</td> <td>2</td> <td>2</td> <td>2</td> <td>2</td> </tr> <tr> <td>Z-40°C/Z+20°C</td> <td>3</td> <td>3</td> <td>3</td> <td>3</td> <td>3</td> <td>3</td> <td>3</td> <td>3</td> </tr> </table> <p>(120Hz)</p>	Rated voltage (V)	6.3	10	16	25	35	50	63	80	100	Impedance ratio (max.)	Z-25°C/Z+20°C	2	2	2	2	2	2	2	2	Z-40°C/Z+20°C	3	3	3	3	3	3	3	3
Rated voltage (V)	6.3	10	16	25	35	50	63	80	100																					
Impedance ratio (max.)	Z-25°C/Z+20°C	2	2	2	2	2	2	2	2																					
	Z-40°C/Z+20°C	3	3	3	3	3	3	3	3																					
Endurance (105°C) (Applied ripple current)	<table border="1"> <tr> <td>Test time</td> <td>5L & 7L : 1000 hours φ5 & φ6.3 : 2000 hours (63 to 100VV:5000 hours) φ8 & φ10 : 3000 hours (63 to 100VV:7000 hours) φ12.5 to φ18 : 5000 hours (63 to 100VV:10000 hours)</td> </tr> <tr> <td>Leakage current</td> <td>The initial specified value or less</td> </tr> <tr> <td>Percentage of capacitance change</td> <td>Within ±25% of initial value</td> </tr> <tr> <td>Tangent of the loss angle</td> <td>200% or less of the initial specified value</td> </tr> </table>	Test time	5L & 7L : 1000 hours φ5 & φ6.3 : 2000 hours (63 to 100VV:5000 hours) φ8 & φ10 : 3000 hours (63 to 100VV:7000 hours) φ12.5 to φ18 : 5000 hours (63 to 100VV:10000 hours)	Leakage current	The initial specified value or less	Percentage of capacitance change	Within ±25% of initial value	Tangent of the loss angle	200% or less of the initial specified value																					
Test time	5L & 7L : 1000 hours φ5 & φ6.3 : 2000 hours (63 to 100VV:5000 hours) φ8 & φ10 : 3000 hours (63 to 100VV:7000 hours) φ12.5 to φ18 : 5000 hours (63 to 100VV:10000 hours)																													
Leakage current	The initial specified value or less																													
Percentage of capacitance change	Within ±25% of initial value																													
Tangent of the loss angle	200% or less of the initial specified value																													
Shelf life (105°C)	<table border="1"> <tr> <td>Test time</td> <td>1000 hours</td> </tr> <tr> <td>Leakage current</td> <td>The initial specified value or less</td> </tr> <tr> <td>Percentage of capacitance change</td> <td>Within ±25% of initial value</td> </tr> <tr> <td>Tangent of the loss angle</td> <td>200% or less of the initial specified value</td> </tr> </table> <p>Voltage application treatment</p>	Test time	1000 hours	Leakage current	The initial specified value or less	Percentage of capacitance change	Within ±25% of initial value	Tangent of the loss angle	200% or less of the initial specified value																					
Test time	1000 hours																													
Leakage current	The initial specified value or less																													
Percentage of capacitance change	Within ±25% of initial value																													
Tangent of the loss angle	200% or less of the initial specified value																													
Applicable standards	JIS C5101-1, -4 1998 (IEC 60384-1 1992, -4 1985)																													

Miniature Aluminum Electrolytic Capacitors

Outline Drawing

Unit : mm

φD	4	5	6.3	8	10	12.5	16	18
F	1.5	2.0	2.5	3.5	5.0	5.0	7.5	7.5
φd	0.45	0.5	0.5	0.6	0.6	0.6	0.8	0.8
α	1.0	1.0	1.0	1.0	2.0	2.0	2.0	2.0

- The electric characteristics are described on page 172.

Coefficient of Frequency for Rated Ripple Current

Rated capacitance (µF) \ Frequency (Hz)	120	1k	10k	100k
5.6 to 180	0.40	0.75	0.90	1
220 to 390	0.50	0.85	0.94	1
470 to 1800	0.60	0.87	0.95	1
2200 to 3900	0.75	0.90	0.95	1
4700 to 6800	0.85	0.95	0.98	1

Part numbering system (example : 10V1000µF)

RJF	—	10	V	102	M	H4	#	—	□
Series code		Rated voltage symbol		Rated capacitance symbol	Capacitance tolerance symbol	Casing symbol			Taping(Forming) symbol

- The standard ratings are described on the next page.

NOTE

Design, Specifications are subject to change without notice. Ask factory for technical specifications before purchase and/or use.

Standard Ratings

Rated voltage (V)	Item	6.3					10					16				
		Case	Casing symbol	Impedance (Ω max.)		Rated ripple current (mA _{rms})	Case	Casing symbol	Impedance (Ω max.)		Rated ripple current (mA _{rms})	Case	Casing symbol	Impedance (Ω max.)		Rated ripple current (mA _{rms})
				20°C	-10°C				20°C	-10°C				20°C	-10°C	
18	—	—	—	—	—	—	—	—	—	—	4×7	D1	0.92	2.8	130	
27	—	—	—	—	—	4×7	D1	0.89	2.7	130	6.3×5	F0	0.30	0.95	210	
33	—	—	—	—	—	—	—	—	—	—	5×7	E1	0.45	1.4	210	
39	4×7	D1	0.85	2.6	130	—	—	—	—	—	6.3×5	F0	0.30	0.95	210	
47	—	—	—	—	—	6.3×5	F0	0.29	0.93	210	—	—	—	—	—	
56	—	—	—	—	—	5×7	E1	0.44	1.4	210	5×11.5	E3	0.22	0.80	345	
68	5×7	E1	0.43	1.3	210	—	—	—	—	—	6.3×7	F1	0.24	0.72	300	
100	6.3×5	F0	0.28	0.91	210	5×11.5	E3	0.22	0.8	345	—	—	—	—	—	
120	—	—	—	—	—	6.3×7	F1	0.23	0.69	300	8×7	G1	0.15	0.45	380	
150	5×11.5	E3	0.22	0.80	345	—	—	—	—	—	6.3×11.5	F3	0.094	0.35	540	
180	6.3×7	F1	0.23	0.69	300	—	—	—	—	—	—	—	—	—	—	
220	—	—	—	—	—	8×7	G1	0.15	0.45	380	—	—	—	—	—	
330	8×7	G1	0.15	0.45	380	6.3×11.5	F3	0.094	0.35	540	—	—	—	—	—	
470	6.3×11.5	F3	0.094	0.35	540	—	—	—	—	—	8×12	G3	0.056	0.19	945	
560	—	—	—	—	—	8×12	G3	0.056	0.19	945	8×15	G4	0.045	0.15	1250	
680	8×12	G3	0.056	0.19	945	—	—	—	—	—	10×16	H4	0.028	0.10	1760	
820	—	—	—	—	—	10×12.5	H3	0.039	0.14	1330	—	—	—	—	—	
1000	8×15	G4	0.046	0.15	1250	—	—	—	—	—	—	—	—	—	—	
1200	10×12.5	H3	0.039	0.14	1330	10×16	H4	0.028	0.10	1760	10×20	H5	0.020	0.060	1960	
1500	10×16	H4	0.028	0.10	1760	10×20	H5	0.020	0.060	1960	10×25	H6	0.018	0.054	2250	
2200	10×20	H5	0.020	0.060	1960	10×25	H6	0.018	0.054	2250	12.5×20	I5	0.017	0.043	2480	
3300	10×25	H6	0.018	0.054	2250	12.5×20	I5	0.017	0.043	2480	12.5×25	I6	0.015	0.038	2900	
4700	—	—	—	—	—	—	—	—	—	—	16×20	J5	0.015	0.038	3250	
5600	12.5×20	I5	0.017	0.043	2480	12.5×25	I6	0.015	0.038	2900	16×25	J6	0.013	0.035	3630	
6800	12.5×25	I6	0.015	0.038	2900	16×20	J5	0.015	0.038	3250	16×25	J6	0.013	0.035	3630	
8200	16×20	J5	0.015	0.038	3570	16×25	J6	0.013	0.035	3630	—	—	—	—	—	
10000	16×25	J6	0.013	0.035	3630	—	—	—	—	—	—	—	—	—	—	

Rated voltage (V)	Item	25					35					50				
		Case	Casing symbol	Impedance (Ω max.)		Rated ripple current (mA _{rms})	Case	Casing symbol	Impedance (Ω max.)		Rated ripple current (mA _{rms})	Case	Casing symbol	Impedance (Ω max.)		Rated ripple current (mA _{rms})
				20°C	-10°C				20°C	-10°C				20°C	-10°C	
5.6	—	—	—	—	—	—	—	—	—	—	4×7	D1	1.0	3.0	130	
10	5×5	E0	0.61	1.5	130	5×5	E0	0.63	1.5	130	5×7	E1	0.50	1.5	210	
15	4×7	D1	0.94	2.9	130	4×7	D1	0.96	2.9	130	—	—	—	—	—	
18	—	—	—	—	—	5×7	E1	0.47	1.5	210	—	—	—	—	—	
22	6.3×5	F0	0.31	0.97	210	6.3×5	F0	0.32	1.0	210	6.3×7	F1	0.26	0.78	300	
27	5×7	E1	0.46	1.4	210	—	—	—	—	—	5×11.5	E3	0.34	1.18	238	
33	—	—	—	—	—	5×11.5	E3	0.22	0.80	345	8×7	G1	0.17	0.51	380	
39	—	—	—	—	—	6.3×7	F1	0.25	0.75	300	—	—	—	—	—	
47	5×11.5	E3	0.22	0.80	345	—	—	—	—	—	—	—	—	—	—	
56	6.3×7	F1	0.24	0.72	300	8×7	G1	0.16	0.48	380	6.3×11.5	F3	0.14	0.50	385	
100	6.3×11.5	F3	0.13	0.41	405	6.3×11.5	F3	0.094	0.35	540	—	—	—	—	—	
120	—	—	—	—	—	—	—	—	—	—	8×12	G3	0.074	0.22	724	
150	—	—	—	—	—	8×12	G3	0.056	0.19	945	10×12.5	H3	0.061	0.18	950	
180	—	—	—	—	—	—	—	—	—	—	8×15	G4	0.061	0.18	979	
220	8×12	G3	0.056	0.19	945	10×12.5	H3	0.039	0.14	1330	10×16	H4	0.042	0.12	1370	
270	—	—	—	—	—	8×20	G5	0.029	0.11	1500	10×20	H5	0.030	0.090	1580	
330	10×12.5	H3	0.039	0.14	1330	10×16	H4	0.028	0.10	1760	10×25	H6	0.028	0.085	1870	
470	10×16	H4	0.028	0.10	1760	10×20	H5	0.020	0.060	1960	12.5×20	I5	0.027	0.068	2050	
560	—	—	—	—	—	10×25	H6	0.018	0.054	2250	12.5×25	I6	0.023	0.059	2410	
680	10×20	H5	0.020	0.060	1960	12.5×20	I5	0.017	0.043	2480	16×20	J5	0.023	0.059	2730	
820	10×25	H6	0.018	0.054	2250	—	—	—	—	—	16×20	J5	0.023	0.059	2730	
1000	12.5×20	I5	0.017	0.043	2480	12.5×25	I6	0.015	0.038	2900	16×25	J6	0.021	0.056	3010	
1200	—	—	—	—	—	16×20	J5	0.015	0.038	3250	—	—	—	—	—	
1500	12.5×25	I6	0.015	0.038	2900	16×25	J6	0.013	0.035	3630	—	—	—	—	—	
1800	16×20	J5	0.015	0.038	3250	16×25	J6	0.013	0.035	3630	—	—	—	—	—	
2200	16×25	J6	0.013	0.035	3630	—	—	—	—	—	—	—	—	—	—	
2700	16×25	J6	0.013	0.035	3630	—	—	—	—	—	—	—	—	—	—	

(Note) Impedance : 100kHz Rated ripple current : 105°C, 100kHz

Standard Ratings

Rated voltage (V) Rated capacitance (µF)	Item	63					80					100							
		Case		Casing symbol	Impedance (Ω max.)		Rated ripple current (mA rms)	Case		Casing symbol	Impedance (Ω max.)		Rated ripple current (mA rms)	Case		Casing symbol	Impedance (Ω max.)		Rated ripple current (mA rms)
		φD	L		20°C	-10°C		φD	L		20°C	-10°C		φD	L		20°C	-10°C	
6.8	—	—	—	—	—	—	—	—	—	—	—	—	5	11.5	E3	1.40	5.60	125	
15	5	11.5	E3	0.88	3.50	165	—	—	—	—	—	—	6.3	11.5	F3	0.57	2.30	205	
27	—	—	—	—	—	—	—	—	—	—	—	—	8	12	G3	0.36	1.40	335	
33	6.3	11.5	F3	0.35	1.40	265	—	—	—	—	—	—	—	—	—	—	—	—	
39	—	—	—	—	—	—	—	—	—	—	—	—	8	15	G4	0.25	1.00	450	
47	—	—	—	—	—	—	—	—	—	—	—	—	10	12.5	H3	0.17	0.66	480	
56	8	12	G3	0.22	0.88	500	—	—	—	—	—	—	8	20	G5	0.19	0.76	565	
68	—	—	—	—	—	—	10	12.5	H3	0.17	0.66	480	10	16	H4	0.11	0.47	600	
82	10	12.5	H3	0.11	0.44	690	—	—	—	—	—	—	10	20	H5	0.084	0.34	800	
100	—	—	—	—	—	—	10	16	H4	0.11	0.47	600	12.5	15	I4	0.11	0.34	750	
120	8	20	G5	0.12	0.48	820	10	20	H5	0.084	0.34	800	10	25	H6	0.069	0.28	900	
	10	16	H4	0.076	0.31	950	—	—	—	—	—	—	—	—	—	—	—	—	
150	—	—	—	—	—	—	10	25	H6	0.069	0.28	900	12.5	20	I5	0.062	0.18	1100	
180	10	20	H5	0.056	0.23	1150	—	—	—	—	—	—	—	—	—	—	—	—	
220	10	25	H6	0.046	0.19	1350	12.5	20	I5	0.062	0.18	1100	16	20	J5	0.048	0.15	1350	
	—	—	—	—	—	—	—	—	—	—	—	—	—	—	—	—	—	—	
270	12.5	20	I5	0.041	0.13	1500	—	—	—	—	—	—	12.5	30	I7	0.042	0.13	1500	
330	—	—	—	—	—	—	12.5	25	I6	0.047	0.14	1250	12.5	35	I8	0.036	0.11	1650	
	—	—	—	—	—	—	16	20	J5	0.048	0.15	1350	16	25	J6	0.038	0.12	1700	
	—	—	—	—	—	—	—	—	—	—	—	—	18	20	K5	0.045	0.14	1500	
390	12.5	25	I6	0.031	0.093	1900	12.5	30	I7	0.042	0.13	1500	12.5	40	I9	0.032	0.095	1800	
470	12.5	30	I7	0.028	0.084	2300	12.5	35	I8	0.036	0.11	1650	16	31.5	J7	0.032	0.095	1850	
	16	20	J5	0.032	0.096	2000	16	25	J6	0.038	0.12	1700	18	25	K6	0.036	0.11	1750	
	—	—	—	—	—	—	18	20	K5	0.045	0.14	1500	—	—	—	—	—	—	
560	12.5	35	I8	0.024	0.07	2500	—	—	—	—	—	—	16	35.5	J8	0.029	0.086	2000	
	—	—	—	—	—	—	—	—	—	—	—	—	18	31.5	K7	0.030	0.090	1900	
680	12.5	40	I9	0.021	0.063	2800	16	31.5	J7	0.032	0.095	1850	16	40	J9	0.027	0.081	2480	
	16	25	J6	0.025	0.075	2600	—	—	—	—	—	—	18	35.5	K8	0.027	0.081	2200	
	18	20	K5	0.030	0.090	2500	—	—	—	—	—	—	—	—	—	—	—	—	
820	16	31.5	J7	0.021	0.063	2850	16	35.5	J8	0.029	0.086	2000	18	40	K9	0.026	0.077	2700	
	18	25	K6	0.024	0.072	2800	18	31.5	K7	0.030	0.090	1900	—	—	—	—	—	—	
1000	16	35.5	J8	0.019	0.057	2900	—	—	—	—	—	—	—	—	—	—	—	—	
1200	16	40	J9	0.018	0.054	3400	18	40	K9	0.026	0.077	2700	—	—	—	—	—	—	
	18	31.5	K7	0.020	0.060	3300	—	—	—	—	—	—	—	—	—	—	—	—	
1500	18	35.5	K8	0.018	0.054	3400	—	—	—	—	—	—	—	—	—	—	—	—	
1800	18	40	K9	0.017	0.051	3500	—	—	—	—	—	—	—	—	—	—	—	—	

(Note) Impedance : 100kHz Rated ripple current : 105°C, 100kHz

105°C Use, Miniature, Long Life, extra Low Impedance Capacitors

GREEN CAP Low Impedance 105°C 10000hours Anti-cleaning solvent

- Long life than RJF Series.
- Guarantees 4000 to 10000 hours at 105°C.

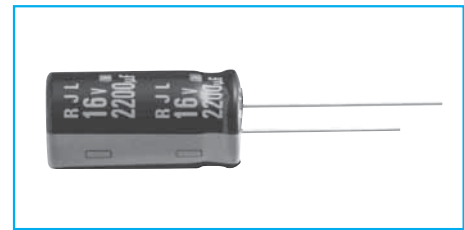
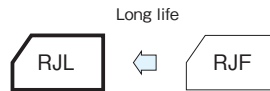

Marking color : White print on a black sleeve

Specifications

Item	Performance																										
Category temperature range (°C)	-40 to +105																										
Tolerance at rated capacitance (%)	±20 (20°C, 120Hz)																										
Leakage current (µA)	Less than 0.01CV or 3 whichever is larger (after 2 minutes) C : Rated capacitance (µF), V : Rated voltage (V) (20°C)																										
Tangent of loss angle (tanδ)	<table border="1"> <thead> <tr> <th>Rated voltage (V)</th> <th>6.3</th> <th>10</th> <th>16</th> <th>25</th> <th>35</th> <th>50</th> <th>63</th> <th>100</th> </tr> </thead> <tbody> <tr> <td>tanδ (max.)</td> <td>0.22</td> <td>0.19</td> <td>0.16</td> <td>0.14</td> <td>0.12</td> <td>0.10</td> <td>0.09</td> <td>0.08</td> </tr> </tbody> </table>	Rated voltage (V)	6.3	10	16	25	35	50	63	100	tanδ (max.)	0.22	0.19	0.16	0.14	0.12	0.10	0.09	0.08								
	Rated voltage (V)	6.3	10	16	25	35	50	63	100																		
tanδ (max.)	0.22	0.19	0.16	0.14	0.12	0.10	0.09	0.08																			
0.02 is added to every 1000µF increase over 1000µF. (20°C, 120Hz)																											
Characteristics at high and low temperature	<table border="1"> <thead> <tr> <th>Rated voltage (V)</th> <th>6.3</th> <th>10</th> <th>16</th> <th>25</th> <th>35</th> <th>50</th> <th>63</th> <th>100</th> </tr> </thead> <tbody> <tr> <td rowspan="2">Impedance ratio (max.)</td> <td>Z-25°C/Z+20°C</td> <td>4</td> <td>3</td> <td>2</td> <td>2</td> <td>2</td> <td>2</td> <td>2</td> </tr> <tr> <td>Z-40°C/Z+20°C</td> <td>8</td> <td>6</td> <td>4</td> <td>3</td> <td>3</td> <td>3</td> <td>3</td> </tr> </tbody> </table>	Rated voltage (V)	6.3	10	16	25	35	50	63	100	Impedance ratio (max.)	Z-25°C/Z+20°C	4	3	2	2	2	2	2	Z-40°C/Z+20°C	8	6	4	3	3	3	3
	Rated voltage (V)	6.3	10	16	25	35	50	63	100																		
Impedance ratio (max.)	Z-25°C/Z+20°C	4	3	2	2	2	2	2																			
	Z-40°C/Z+20°C	8	6	4	3	3	3	3																			
(120Hz)																											
Endurance (105°C) (Applied ripple current)	Test time	φ5, φ6.3 : 5000 hours (6.3~10WV : 4000 hours) φ8, φ10 : 7000 hours (6.3~10WV : 6000 hours) φ12.5, φ16 : 10000 hours (6.3~10WV : 8000 hours)																									
	Leakage current	The initial specified value or less																									
	Percentage of capacitance change	Within ±25% of initial value																									
	Tangent of the loss angle	200% or less of the initial specified value																									
Shelf life (105°C)	Test time	1000 hours																									
	Leakage current	The initial specified value or less																									
	Percentage of capacitance change	Within ±25% of initial value																									
	Tangent of the loss angle	200% or less of initial specified value																									
Voltage application treatment																											
Applicable standards	JIS C5101-1, -4 1998 (IEC 60384-1 1992, -4 1985)																										

Outline Drawing

Unit : mm

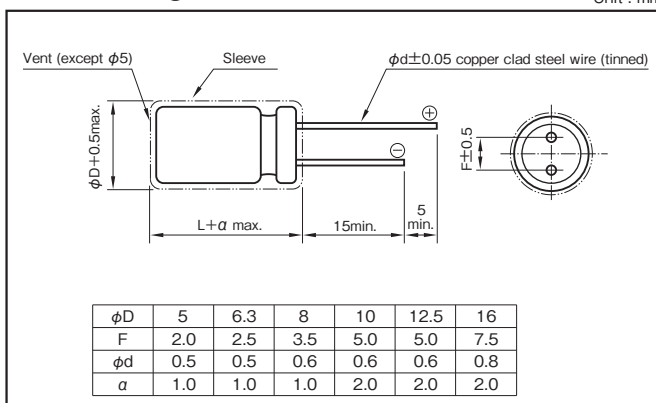

Coefficient of Frequency for Rated Ripple Current

Rated capacitance (µF)	Frequency (Hz)			
	120	1k	10k	100k
to 33	0.42	0.70	0.90	1.00
47 to 270	0.50	0.73	0.92	1.00
330 to 680	0.55	0.77	0.94	1.00
820 to 1800	0.60	0.80	0.96	1.00
2200 to 6800	0.70	0.85	0.98	1.00

Part numbering system (example : 10V1000µF)

RJL	—	10	V	102	M	H4	#	—	□
Series code		Rated voltage symbol		Rated capacitance symbol	Capacitance tolerance symbol	Casing symbol			Taping(Forming) symbol

NOTE

Design, Specifications are subject to change without notice. Ask factory for technical specifications before purchase and/or use.

Standard Ratings

Rated voltage (V)	Item	6.3					10					16				
		Case	Casing symbol	Impedance (Ω max.)		Rated ripple current (mAmps)	Case	Casing symbol	Impedance (Ω max.)		Rated ripple current (mAmps)	Case	Casing symbol	Impedance (Ω max.)		Rated ripple current (mAmps)
				20°C	-10°C				20°C	-10°C				20°C	-10°C	
		φD×L (mm)				φD×L (mm)					φD×L (mm)					
Rated capacitance (μF)																
56	—	—	—	—	—	—	—	—	—	—	5×11.5	E3	0.58	2.3	210	
100	—	—	—	—	—	5×11.5	E3	0.58	2.3	210	—	—	—	—	—	
120	—	—	—	—	—	—	—	—	—	—	6.3×11.5	F3	0.22	0.87	340	
150	5×11.5	E3	0.58	2.3	210	—	—	—	—	—	—	—	—	—	—	
220	—	—	—	—	—	6.3×11.5	F3	0.22	0.87	340	—	—	—	—	—	
330	6.3×11.5	F3	0.22	0.87	340	—	—	—	—	—	8×12	G3	0.13	0.52	640	
470	—	—	—	—	—	8×12	G3	0.13	0.52	640	8×15	G4	0.087	0.35	840	
560	8×12	G3	0.13	0.52	640	8×15	G4	0.087	0.35	840	—	—	—	—	—	
680	8×12	G3	0.13	0.52	640	10×12.5	H3	0.080	0.32	865	10×16	H4	0.060	0.24	1210	
820	10×12.5	H3	0.080	0.32	865	10×16	H4	0.060	0.24	1210	10×20	H5	0.046	0.18	1400	
1000	8×15	G4	0.087	0.35	840	10×16	H4	0.060	0.24	1210	10×20	H5	0.046	0.18	1400	
1200	10×16	H4	0.060	0.24	1210	10×20	H5	0.046	0.18	1400	10×25	H6	0.042	0.17	1650	
1500	10×20	H5	0.046	0.18	1400	10×25	H6	0.042	0.17	1650	12.5×20	I5	0.035	0.12	1900	
1800	10×25	H6	0.042	0.17	1650	12.5×20	I5	0.035	0.12	1900	12.5×25	I6	0.027	0.089	2230	
2200	10×25	H6	0.042	0.17	1650	12.5×20	I5	0.035	0.12	1900	12.5×25	I6	0.027	0.089	2230	
2700	—	—	—	—	—	—	—	—	—	—	16×20	J5	0.027	0.078	2530	
3300	12.5×20	I5	0.035	0.12	1900	12.5×25	I6	0.027	0.089	2230	12.5×35	I8	0.020	0.065	2880	
3900	—	—	—	—	—	—	—	—	—	—	16×25	J6	0.021	0.060	2930	
4700	12.5×30	I7	0.024	0.078	2650	12.5×35	I8	0.020	0.065	2880	—	—	—	—	—	
5600	16×20	J5	0.027	0.078	2530	16×25	J6	0.021	0.060	2930	—	—	—	—	—	
6800	16×25	J6	0.021	0.060	2930	—	—	—	—	—	—	—	—	—	—	

Rated voltage (V)	Item	25					35					50				
		Case	Casing symbol	Impedance (Ω max.)		Rated ripple current (mAmps)	Case	Casing symbol	Impedance (Ω max.)		Rated ripple current (mAmps)	Case	Casing symbol	Impedance (Ω max.)		Rated ripple current (mAmps)
				20°C	-10°C				20°C	-10°C				20°C	-10°C	
		φD×L (mm)				φD×L (mm)					φD×L (mm)					
Rated capacitance (μF)																
10	—	—	—	—	—	—	—	—	—	—	5×11.5	E3	1.50	6.0	100	
22	—	—	—	—	—	—	—	—	—	—	5×11.5	E3	0.70	2.8	180	
33	—	—	—	—	—	5×11.5	E3	0.58	2.3	210	—	—	—	—	—	
47	5×11.5	E3	0.58	2.3	210	—	—	—	—	—	—	—	—	—	—	
56	—	—	—	—	—	6.3×11.5	F3	0.22	0.87	340	6.3×11.5	F3	0.30	1.2	295	
100	6.3×11.5	F3	0.22	0.87	340	—	—	—	—	—	8×12	G3	0.17	0.68	555	
120	—	—	—	—	—	—	—	—	—	—	8×15	G4	0.12	0.48	730	
150	—	—	—	—	—	8×12	G3	0.13	0.52	640	10×12.5	H3	0.12	0.48	760	
180	—	—	—	—	—	8×15	G4	0.087	0.35	870	8×20	G5	0.091	0.36	910	
220	8×12	G3	0.13	0.52	640	8×15	G4	0.087	0.35	870	10×16	H4	0.084	0.34	1050	
270	—	—	—	—	—	8×20	G5	0.069	0.27	1050	10×20	H5	0.060	0.24	1220	
330	8×15	G4	0.087	0.35	840	10×16	H4	0.060	0.24	1210	10×25	H6	0.055	0.22	1440	
470	10×16	H4	0.060	0.24	1210	10×20	H5	0.046	0.18	1400	12.5×20	I5	0.045	0.15	1660	
560	—	—	—	—	—	10×25	H6	0.042	0.17	1650	12.5×25	I6	0.034	0.11	1950	
680	10×20	H5	0.046	0.18	1400	12.5×20	I5	0.035	0.12	1900	12.5×25	I6	0.034	0.11	1950	
820	10×25	H6	0.042	0.17	1650	12.5×25	I6	0.027	0.089	2230	12.5×30	I7	0.030	0.10	2310	
1000	12.5×20	I5	0.035	0.12	1900	12.5×25	I6	0.027	0.089	2230	16×25	J6	0.025	0.075	2555	
1200	12.5×25	I6	0.027	0.089	2230	16×20	J5	0.027	0.078	2530	—	—	—	—	—	
1500	12.5×25	I6	0.027	0.089	2230	12.5×35	I8	0.020	0.065	2880	—	—	—	—	—	
1800	16×20	J5	0.027	0.078	2530	16×25	J6	0.021	0.060	2930	—	—	—	—	—	
2200	12.5×35	I8	0.020	0.065	2880	—	—	—	—	—	—	—	—	—	—	
2700	16×25	J6	0.021	0.060	2930	—	—	—	—	—	—	—	—	—	—	

Rated voltage (V)	Item	63					100				
		Case	Casing symbol	Impedance (Ω max.)		Rated ripple current (mAmps)	Case	Casing symbol	Impedance (Ω max.)		Rated ripple current (mAmps)
				20°C	-10°C				20°C	-10°C	
		φD×L (mm)				φD×L (mm)					
Rated capacitance (μF)											
6.8	—	—	—	—	—	5×11.5	E3	2.3	9.3	55	
15	5×11.5	E3	2.3	9.3	55	6.3×11.5	F3	1.2	5.0	115	
27	6.3×11.5	F3	1.2	5.0	115	8×12	G3	0.63	2.8	232	
47	—	—	—	—	—	10×12.5	H3	0.43	1.8	288	
56	8×12	G3	0.63	2.8	232	8×20	G5	0.33	1.6	362	
68	—	—	—	—	—	10×16	H4	0.31	1.5	357	
82	8×15	G4	0.45	2.1	300	10×20	H5	0.21	0.94	466	
100	—	—	—	—	—	10×25	H6	0.20	0.84	531	
120	10×16	H4	0.31	1.5	357	12.5×20	I5	0.16	0.64	690	
180	10×20	H5	0.21	0.94	466	12.5×25	I6	0.120	0.45	784	
220	10×25	H6	0.20	0.84	531	16×20	J5	0.091	0.38	1040	
270	12.5×20	I5	0.16	0.64	690	16×25	J6	0.073	0.27	1250	
330	12.5×25	I6	0.12	0.45	784	—	—	—	—	—	
390	16×20	J5	0.091	0.38	1040	—	—	—	—	—	
470	16×20	J5	0.091	0.38	1040	—	—	—	—	—	
560	16×25	J6	0.073	0.27	1250	—	—	—	—	—	

(Note) Impedance : 100kHz ; Rated ripple current : 105°C, 100kHz

NOTE

Design, Specifications are subject to change without notice.
Ask factory for technical specifications before purchase and/or use.

105°C Use, miniature, Hi-Reliability, Low impedance Capacitors

GREEN CAP	Low Impedance	105°C 8000hours	Anti-cleaning solvent
-----------	---------------	-----------------	-----------------------

- Smaller and higher ripple current than RJB series.
- Guarantees 8000 hours at 105°C.
($\phi 5$ to 6.3: 2000 hours: $\phi 8$ to 10: 3000 hours)

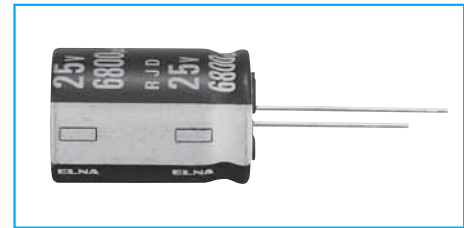
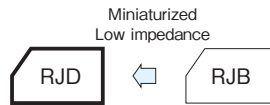

Marking color : White print on a black sleeve

Specifications

Item	Performance					
Category temperature range (°C)	-55 to +105					
Tolerance at rated capacitance (%)	±20 (20°C, 120Hz)					
Leakage current (µA)	Less than 0.01CV or 3 whichever is larger (after 2 minutes) C : Rated capacitance (µF), V : Rated voltage (V) (20°C)					
Tangent of loss angle (tanδ)	Rated voltage (V)	6.3	10	16	25	35
	tanδ (max.)	0.22	0.19	0.16	0.14	0.12
0.02 is added to every 1000µF increase over 1000µF. (20°C, 120Hz)						
Characteristics at high and low temperature	Rated voltage (V)	6.3	10	16	25	35
	Impedance ratio (max.)	Z-55°C/Z+20°C	3	3	3	3
(120Hz)						
Endurance (105°C) (Applied ripple current)	Test time	$\phi 5$ to 6.3: 2000 hours $\phi 8$ to 10: 3000 hours $\phi 12.5$ to 18: 8000 hours				
	Leakage current	The initial specified value or less				
	Percentage of capacitance change	Within ±20% of initial value				
	Tangent of the loss angle	200% or less of the initial specified value				
Shelf life (105°C)	Test time : 1000 hours ; other items are the same as those for the endurance. Voltage application treatment					
Applicable standards	JIS C5101-1, -4 1998 (IEC 60384-1 1992, -4 1985)					

Outline Drawing

Unit : mm

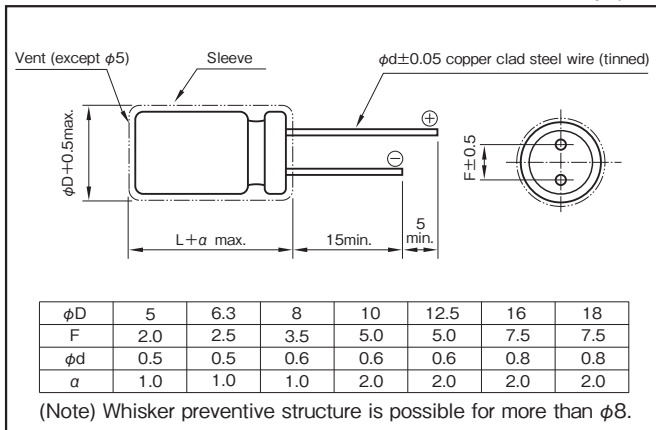

Coefficient of Frequency for Rated Ripple Current

Rated Capacitance (µF)	Frequency (Hz)				
	50 · 60	120	300	1k	10k · 100k
to 56	0.20	0.30	0.50	0.80	1
68 to 330	0.55	0.65	0.75	0.85	1
390 to 1000	0.70	0.75	0.80	0.90	1
1200 to 18000	0.80	0.85	0.90	0.95	1

Part numbering system (example : 6.3V10000µF)

RJD	—	6	V	103	M	J7	#	—	□
Series code		Rated voltage symbol		Rated capacitance symbol	Capacitance tolerance symbol	Casing symbol			Taping/Forming symbol

If it is whisker preventive structure, should change “#” into “G”.

Standard Ratings

Rated voltage(V)	Item	6.3					10					16												
		Case		Casing symbol	Impedance (Ω max.)		Rated ripple current (mA rms)	Case		Casing symbol	Impedance (Ω max.)		Rated ripple current (mA rms)	Case		Casing symbol	Impedance (Ω max.)		Rated ripple current (mA rms)					
		φD	L		20°C	-10°C		φD	L		20°C	-10°C		φD	L		20°C	-10°C						
22	—	—	—	—	—	—	—	—	—	—	—	—	5	11.5	E3	0.5	1.0	182						
33	—	—	—	—	—	—	—	—	—	—	—	—	5	11.5	E3	0.5	1.0	182						
47	—	—	—	—	—	—	—	—	—	—	—	—	5	11.5	E3	0.5	1.0	182						
82	—	—	—	—	—	—	—	—	—	—	—	—	5	15	E4	0.46	0.92	237						
100	—	—	—	—	—	—	5	11.5	E3	0.5	1.0	182	6.3	11.5	F3	0.25	0.50	295						
150	5	11.5	E3	0.50	1.0	182	—	—	—	—	—	—	6.3	11.5	F3	0.25	0.50	295						
180	—	—	—	—	—	—	6.3	11.5	F3	0.25	0.50	295	6.3	15	F4	0.18	0.36	432						
220	—	—	—	—	—	—	6.3	11.5	F3	0.25	0.50	295	6.3	15	F4	0.18	0.36	432						
330	6.3	11.5	F3	0.25	0.5	295	6.3	15	F4	0.18	0.36	432	8	12	G3	0.117	0.234	567						
390	—	—	—	—	—	—	—	—	—	—	—	—	8	12	G3	0.117	0.234	567						
470	6.3	15	F4	0.18	0.36	432	8	12	G3	0.117	0.234	567	8	15	G4	0.085	0.170	733						
													10	12.5	H3	0.090	0.180	764						
560	8	12	G3	0.117	0.234	567	8	12	G3	0.117	0.234	567	8	20	G5	0.065	0.130	996						
680	8	12	G3	0.117	0.234	567	—	—	—	—	—	—	8	15	G4	0.085	0.170	733						
													10	12.5	H3	0.090	0.180	764						
820	—	—	—	—	—	—	8	15	G4	0.085	0.170	733	8	20	G5	0.065	0.130	996						
													10	12.5	H3	0.090	0.180	764						
1000	8	15	G4	0.085	0.170	733	8	20	G5	0.065	0.130	996	10	16	H4	0.068	0.136	1060						
													10	12.5	H3	0.090	0.180	764						
1200	10	12.5	H3	0.090	0.180	764	8	20	G5	0.065	0.130	996	10	20	H5	0.052	0.104	1230						
													10	16	H4	0.068	0.136	1060						
1500	8	20	G5	0.065	0.130	996	10	20	H5	0.052	0.104	1230	10	25	H6	0.045	0.090	1450						
													10	16	H4	0.068	0.136	1060						
1800	12.5	15	I4	0.062	0.124	1210	10	20	H5	0.052	0.104	1230	—	—	—	—	—	—						
													10	25	H6	0.045	0.090	1450						
2200	10	20	H5	0.052	0.104	1230	10	25	H6	0.045	0.090	1450	10	30	H7	0.035	0.070	1830						
													12.5	20	I5	0.038	0.076	1700						
													16	16	J4	0.043	0.086	1700						
2700	10	25	H6	0.045	0.090	1450	10	30	H7	0.035	0.070	1830	12.5	25	I6	0.030	0.060	1950						
													12.5	20	I5	0.038	0.076	1700						
3300	10	30	H7	0.035	0.070	1830	12.5	25	I6	0.030	0.060	1950	12.5	30	I7	0.025	0.050	2330						
													16	20	J5	0.029	0.058	2230						
3900	12.5	25	I6	0.030	0.060	1950	12.5	25	I6	0.030	0.060	1950	12.5	35	I8	0.022	0.044	2620						
													18	16	K4	0.038	0.076	2010						
4700	12.5	25	I6	0.030	0.060	1950	12.5	30	I7	0.025	0.050	2330	12.5	40	I9	0.017	0.034	3160						
													16	25	J6	0.022	0.044	2650						
													18	20	K5	0.028	0.056	2500						
5600	12.5	30	I7	0.025	0.050	2330	12.5	35	I8	0.022	0.044	2620	16	25	J6	0.220	0.440	2650						
													16	20	J5	0.029	0.058	2230						
6800	12.5	35	I8	0.022	0.044	2620	12.5	40	I9	0.017	0.034	3160	18	25	K6	0.020	0.040	3000						
													16	25	J6	0.022	0.044	2650						
8200	12.5	40	I9	0.017	0.034	3160	16	31.5	J7	0.018	0.036	3210	18	35.5	K8	0.015	0.030	3960						
																			16	25	J6	0.022	0.044	2650
																			18	20	K5	0.028	0.056	2500
10000	16	31.5	J7	0.018	0.036	3210	16	40	J9	0.015	0.030	3880	18	40	K9	0.014	0.028	4300						
																			18	25	K6	0.020	0.040	3000
12000	18	25	K6	0.020	0.040	3000	—	—	—	—	—	—	—	—	—	—	—							
15000	18	35.5	K8	0.015	0.030	3960	18	40	K9	0.014	0.028	4300	—	—	—	—	—	—						
18000	18	40	K9	0.014	0.028	4300	—	—	—	—	—	—	—	—	—	—	—							

(Note) Rated ripple current : 105°C , 100kHz, Impedance : 20°C , 100kHz

Standard Ratings

Rated voltage(V) Rated capacitance (μF)	Item	25						35					
		Case		Casing symbol	Impedance (Ω max.)		Rated ripple current (mA rms)	Case		Casing symbol	Impedance (Ω max.)		Rated ripple current (mA rms)
		φD	L		20°C	-10°C		φD	L		20°C	-10°C	
10		5.0	11.5	E3	0.50	1.0	182	5.0	11.5	E3	0.50	1.0	182
22		5.0	11.5	E3	0.50	1.0	182	5.0	11.5	E3	0.50	1.0	182
27		5.0	11.5	E3	0.50	1.0	182	5.0	11.5	E3	0.50	1.0	182
33		5.0	11.5	E3	0.50	1.0	182	5.0	11.5	E3	0.50	1.0	182
47		5.0	11.5	E3	0.50	1.0	182	6.3	11.5	F3	0.25	0.50	295
56		5.0	15	E4	0.46	0.92	237	6.3	11.5	F3	0.25	0.50	295
82		6.3	11.5	F3	0.25	0.50	295	6.3	15	F4	0.18	0.36	432
100		6.3	11.5	F3	0.25	0.50	295	8.0	12	G3	0.117	0.234	567
120		6.3	15	F4	0.18	0.36	432	—	—	—	—	—	—
150		8.0	12	G3	0.117	0.234	567	8.0	12	G3	0.117	0.234	567
180		—	—	—	—	—	—	8.0	12	G3	0.117	0.234	567
220		8.0	12	G3	0.117	0.234	567	8.0	15	G4	0.085	0.170	733
270		8.0	12	G3	0.117	0.234	567	8.0	15	G4	0.085	0.170	733
								10.0	12.5	H3	0.090	0.180	764
330		8.0	12	G3	0.117	0.234	567	8.0	20	G5	0.065	0.130	996
		10.0	12.5	H3	0.090	0.180	764	10.0	16	H4	0.068	0.136	1060
390		8.0	15	G4	0.085	0.170	733	8.0	20	G5	0.065	0.130	996
								10.0	16	H4	0.068	0.136	1060
470		8.0	15	G4	0.085	0.170	733	10.0	20	H5	0.052	0.104	1230
		10.0	12.5	H3	0.090	0.180	764						
560		8.0	20	G5	0.065	0.130	996	10.0	20	H5	0.052	0.104	1230
		10.0	16	H4	0.068	0.136	1060	12.5	15	I4	0.062	0.124	1210
680		10.0	16	H4	0.068	0.136	1060	10.0	25	H6	0.045	0.090	1450
820		10.0	20	H5	0.052	0.104	1230	12.5	20	I5	0.038	0.076	1700
		12.5	15	I4	0.062	0.124	1210						
1000		10.0	25	H6	0.045	0.090	1450	10.0	30	H7	0.035	0.070	1830
		12.5	20	I5	0.038	0.076	1700	12.5	20	I5	0.038	0.076	1700
1200		12.5	20	I5	0.038	0.076	1700	12.5	25	I6	0.030	0.060	1950
								18.0	16	K4	0.038	0.076	2010
1500		10.0	30	H7	0.035	0.070	1830	12.5	30	I7	0.025	0.050	2330
		16.0	16	J4	0.043	0.086	1700	16.0	20	J5	0.029	0.058	2230
1800		12.5	25	I6	0.030	0.060	1950	12.5	35	I8	0.022	0.044	2620
		18.0	16	K4	0.038	0.076	2010	16.0	20	J5	0.029	0.058	2230
2200		12.5	30	I7	0.025	0.050	2330	12.5	40	I9	0.017	0.034	3160
		16.0	20	J5	0.029	0.058	2230	16.0	25	J6	0.022	0.044	2650
2700		18.0	20	K5	0.028	0.056	2500	18.0	20	K5	0.028	0.056	2500
		12.5	35	I8	0.022	0.044	2620	16.0	31.5	J7	0.018	0.036	3210
3300		18.0	25	K6	0.020	0.040	3000	18.0	25	K6	0.020	0.040	3000
		12.5	40	I9	0.017	0.034	3160	18.0	31.5	K7	0.016	0.032	3660
3900		16.0	25	J6	0.022	0.044	2650	18.0	31.5	K7	0.016	0.032	3660
		18.0	20	K5	0.028	0.056	2500	18.0	20	K5	0.028	0.056	2500
4700		—	—	—	—	—	—	18.0	35.5	K8	0.015	0.030	3960
		—	—	—	—	—	—	18.0	40	K9	0.014	0.028	4300
5600		18.0	25	K6	0.020	0.040	3000	18.0	35.5	K8	0.015	0.030	3960
		18.0	25	K6	0.020	0.040	3000	18.0	40	K9	0.014	0.028	4300
6800		18.0	35.5	K8	0.015	0.030	3960	18.0	40	K9	0.014	0.028	4300
8200		18.0	35.5	K8	0.015	0.030	3960	18.0	40	K9	0.014	0.028	4300

(Note) Rated ripple current : 105°C , 100kHz, Impedance : 20°C , 100kHz

Aluminum Electrolytic Capacitors

For AirBag GREEN CAP 105°C 5000hours Anti-cleaning solvent For AirBag

- For AirBag application
- High capacitance, low impedance, and good low temperature behavior
- Guarantees 5000 hours at 105°C.

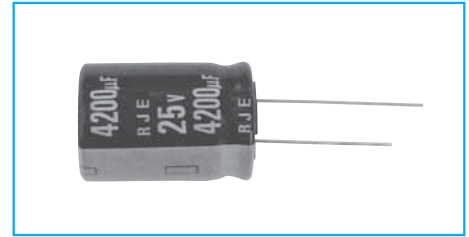

Marking color : White print on a black sleeve

Specifications

Item	Performance	
Category temperature range (°C)	-55 to +105	
Tolerance at rated capacitance (%)	0 to +30 (20°C,120Hz)	
Leakage current (µA)	Less than 0.01CV (after 2 minutes) C : Rated capacitance (µF) , V : Rated voltage (V) (20°C)	
Tangent of loss angle (tanδ)	Rated voltage (V)	25 35
	tanδ (max.)	0.20 0.16
0.02 is added to every 1000µF increase over 1000µF (20°C,120Hz)		
Characteristics at high and low temperature	Rated voltage (V)	25 35
	Impedance ratio (max.) Z-55°C/Z+20°C	3 3
(120Hz)		
Endurance (105°C)	Test time	5000 hours
	Leakage current	The initial specified value or less
	Percentage of capacitance change	Within -20% to +20% of initial value
	Tangent of loss angle	200% or less of the initial specified value
Shelf life (105°C)	Test time : 1000 hours ; other items are the same as those for the endurance. Voltage application treatment	
Applicable standards	JIS C5101-1, -18 1998 (IEC 60384-1 1992, -4 1985)	

Outline Drawing

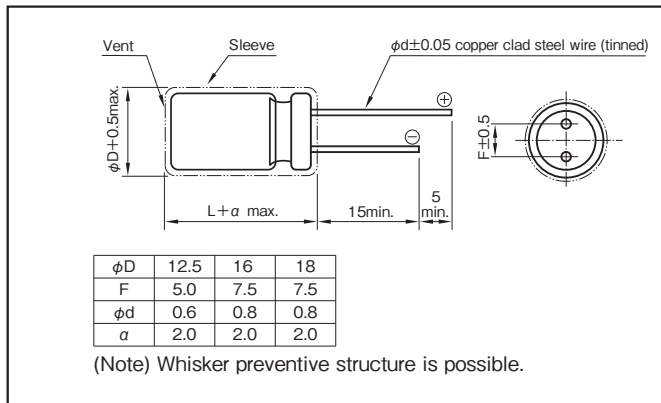

Coefficient of Frequency for Rated Ripple Current

Frequency (Hz)	50 · 60	120	1k	10k·100k
Rated capacitance (µF)				
830 to 1100	0.70	0.75	0.90	1
1200 to 11000	0.80	0.85	0.95	1

Part numbering system (example : 25V422 A I9 (#)Q)



If it is whisker preventive structure, should change “#” into “G”.

Standard Ratings

Case size φD×L (mm)	Casing symbol	25				35			
		Capacitance (µF)	ESR Ω (max.) / 100kHz		Rated ripple current (mA rms)	Capacitance (µF)	ESR Ω (max.) / 100kHz		Rated ripple current (mA rms)
			20°C	-40°C			20°C	-40°C	
12.5×15	I4	1100	0.174	0.52	1210	830	0.174	0.52	1210
12.5×20	I5	1800	0.107	0.27	1670	1300	0.107	0.27	1670
12.5×25	I6	2400	0.084	0.21	1950	1600	0.084	0.21	1950
12.5×30	I7	3200	0.070	0.18	2330	2200	0.070	0.18	2330
12.5×35	I8	3700	0.062	0.16	2620	2500	0.062	0.16	2620
12.5×40	I9	4200	0.048	0.12	3160	2900	0.048	0.12	3160
16×16	J4	2100	0.121	0.36	1700	1500	0.121	0.36	1700
16×20	J5	3100	0.082	0.21	2230	2100	0.082	0.21	2230
16×25	J6	4300	0.062	0.16	2650	3000	0.062	0.16	2650
16×31.5	J7	5800	0.051	0.13	3210	4000	0.051	0.13	3210
16×35.5	J8	6800	0.045	0.11	3570	4600	0.045	0.11	3570
16×40	J9	7800	0.042	0.11	3880	5300	0.042	0.11	3880
18×16	K4	3000	0.107	0.32	2010	2100	0.107	0.32	2010
18×20	K5	4300	0.079	0.20	2500	3000	0.079	0.20	2500
18×25	K6	6000	0.056	0.14	3000	4200	0.056	0.14	3000
18×31.5	K7	8000	0.045	0.11	3660	5600	0.045	0.11	3660
18×35.5	K8	9300	0.042	0.11	3960	6500	0.042	0.11	3960
18×40	K9	11000	0.040	0.10	4300	7400	0.040	0.10	4300

(Note) Rated ripple current : 105°C, 100kHz

NOTE

Design, Specifications are subject to change without notice. Ask factory for technical specifications before purchase and/or use.

105°C Use, Miniature, High-Ripple, Long Life Capacitors

GREEN CAP

105°C
5000hours

- Higher ripple current.
- Guarantees 4000 to 5000 hours at 105°C.
- Best-suited to electronic ballast.

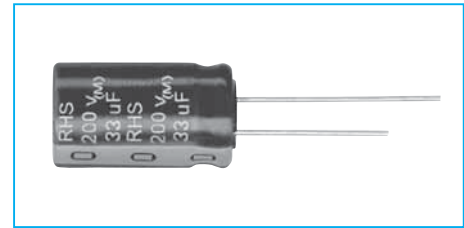
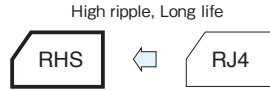

Marking color : White print on a black sleeve

Specifications

Item	Performance														
Category temperature range (°C)	-40 to +105 (-25 to +105 at 350V or more)														
Rated Voltage (V)	160 to 450														
Tolerance at rated capacitance (%)	±20 (20°C, 120Hz)														
Leakage current (µA)	CV≥1000 : Less than 0.06CV+40 (after 1 minutes) CV<1000 : Less than 0.03CV+70 (after 1 minutes) C : Rated capacitance (µF), V : Rated voltage (V) (20°C)														
Tangent of loss angle	<table border="1"> <tr> <td>Rated voltage (V)</td> <td>160 to 250</td> <td>350 to 400</td> <td>450</td> </tr> <tr> <td>Tangent of loss angle</td> <td>0.12</td> <td>0.15</td> <td>0.20</td> </tr> </table> <p>(20°C, 120Hz)</p>	Rated voltage (V)	160 to 250	350 to 400	450	Tangent of loss angle	0.12	0.15	0.20						
Rated voltage (V)	160 to 250	350 to 400	450												
Tangent of loss angle	0.12	0.15	0.20												
Characteristics at high and low temperature	<table border="1"> <tr> <td>Rated voltage (V)</td> <td>160 to 250</td> <td>350 to 450</td> </tr> <tr> <td rowspan="2">Impedance ratio</td> <td>Z-25°C/Z+20°C</td> <td>3</td> </tr> <tr> <td>Z-40°C/Z+20°C</td> <td>4</td> </tr> <tr> <td></td> <td></td> <td>6</td> </tr> <tr> <td></td> <td></td> <td>-</td> </tr> </table> <p>(120Hz)</p>	Rated voltage (V)	160 to 250	350 to 450	Impedance ratio	Z-25°C/Z+20°C	3	Z-40°C/Z+20°C	4			6			-
Rated voltage (V)	160 to 250	350 to 450													
Impedance ratio	Z-25°C/Z+20°C	3													
	Z-40°C/Z+20°C	4													
		6													
		-													
Endurance (105°C) (Applied ripple current)	<table border="1"> <tr> <td>Test time</td> <td>φ10 : 4000 hours φ12.5 to 18 : 5000 hours</td> </tr> <tr> <td>Leakage current</td> <td>The initial specified value or less</td> </tr> <tr> <td>Capacitance change</td> <td>Within -20% to +20% of initial value</td> </tr> <tr> <td>Tangent of loss angle</td> <td>300% or less of the initial specified value</td> </tr> </table>	Test time	φ10 : 4000 hours φ12.5 to 18 : 5000 hours	Leakage current	The initial specified value or less	Capacitance change	Within -20% to +20% of initial value	Tangent of loss angle	300% or less of the initial specified value						
Test time	φ10 : 4000 hours φ12.5 to 18 : 5000 hours														
Leakage current	The initial specified value or less														
Capacitance change	Within -20% to +20% of initial value														
Tangent of loss angle	300% or less of the initial specified value														
Shelf life (105°C)	<table border="1"> <tr> <td>Test time</td> <td>1000 hours</td> </tr> <tr> <td>Leakage current</td> <td>The initial specified value or less</td> </tr> <tr> <td>Capacitance change</td> <td>Within -20% to +20% of initial value</td> </tr> <tr> <td>Tangent of loss angle</td> <td>200% or less of the initial specified value</td> </tr> </table> <p>Voltage application treatment</p>	Test time	1000 hours	Leakage current	The initial specified value or less	Capacitance change	Within -20% to +20% of initial value	Tangent of loss angle	200% or less of the initial specified value						
Test time	1000 hours														
Leakage current	The initial specified value or less														
Capacitance change	Within -20% to +20% of initial value														
Tangent of loss angle	200% or less of the initial specified value														
Applicable Standards	JIS C 5101-01, -04 1998 (IEC 60384-1 1992, 60384-4 1985)														

Outline Drawing

Unit : mm

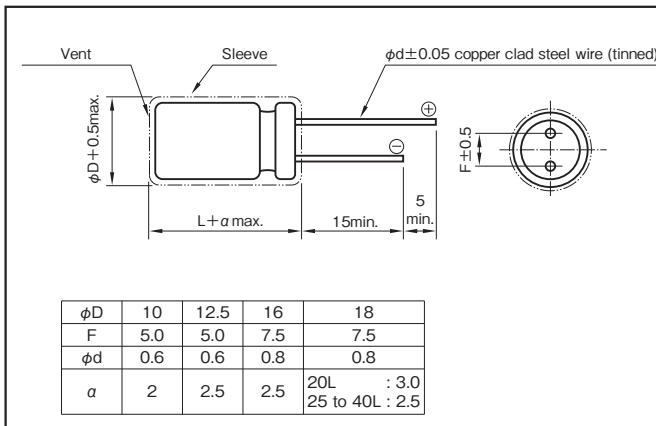

Coefficient of Frequency for Rated Ripple Current

Rated voltage (V)	Frequency (Hz)				
	50,60	120	300	1k	10k or more
160 to 450	0.75	1.00	1.20	1.35	1.50

Part numbering system (example : 400V10µF)

RHS	—	400 V	100	M	I5 #	B	—	□
Series code		Rated voltage symbol	Rated capacitance symbol	Capacitance tolerance symbol	Case symbol	Optional symbol		Taping/Forming symbol

NOTE

Design, Specifications are subject to change without notice.
Ask factory for technical specifications before purchase and/or use.

Standard Ratings

Rated voltage(V)		160			200			250			350			
Case φD×L(mm)	Casing symbol	Item	Rated capacitance (μF)	ESR (Ω max.)	Rated ripple current (mArms)	Rated capacitance (μF)	ESR (Ω max.)	Rated ripple current (mArms)	Rated capacitance (μF)	ESR (Ω max.)	Rated ripple current (mArms)	Rated capacitance (μF)	ESR (Ω max.)	Rated ripple current (mArms)
10×12.5	H3		—	—	—	4.7	41	60	4.7	41	60	3.3	72	50
			—	—	—	—	—	—	10	19	82	4.7	51	55
10×16	H4		10	19	96	10	19	95	10	19	90	4.7	51	65
			—	—	—	22	9.0	111	—	—	—	—	—	—
10×20	H5		22	9.0	145	22	9.0	145	10	19	105	—	—	—
			—	—	—	—	—	—	22	15	150	—	—	—
12.5×20	I5		33	6.0	190	33	6.0	190	—	—	—	10	24	120
12.5×25	I6		47	4.0	280	47	4.0	280	22	9.0	180	22	11	180
			—	—	—	—	—	—	33	6.0	250	—	—	—
16×20	J5		47	4.0	280	47	4.0	280	33	6.0	250	22	11	180
16×25	J6		100	2.0	380	—	—	—	47	4.0	300	33	7.0	210
16×31.5	J7		—	—	—	100	2.0	410	100	2.0	410	—	—	—
16×35.5	J8		—	—	—	—	—	—	—	—	—	47	5.0	300
18×20	K5		100	2.0	380	—	—	—	47	4.0	300	—	—	—
18×25	K6		—	—	—	100	2.0	410	100	2.0	410	—	—	—
18×31.5	K7		—	—	—	—	—	—	—	—	—	47	5.0	300
18×35.5	K8		220	0.9	630	—	—	—	—	—	—	—	—	—

Rated voltage(V)		400			450			
Case φD×L(mm)	Casing symbol	Item	Rated capacitance (μF)	ESR (Ω max.)	Rated ripple current (mArms)	Rated capacitance (μF)	ESR (Ω max.)	Rated ripple current (mArms)
10×12.5	H3		2.2	109	40	1	318	30
10×16	H4		3.3	72	50	2.2	145	45
10×20	H5		4.7	51	70	3.3	96	65
12.5×20	I5		10	24	120	—	—	—
			22	11	200	—	—	—
12.5×25	I6		—	—	—	4.7	68	80
			—	—	—	10	32	140
16×25	J6		22	11	200	22	14	220
			—	—	—	33	10	280
16×31.5	J7		33	7.0	245	47	5.6	420
16×35.5	J8		82	3.2	500	68	3.9	520
18×20	K5		22	11	200	—	—	—
18×25	K6		33	7.0	245	68	3.9	424
18×31.5	K7		47	5.0	300	82	3.2	580
			82	3.2	500	—	—	—
18×35.5	K8		—	—	—	100	2.6	750
18×40	K9		—	—	—	120	2.2	800

(Note) ESR : 20°C, 120Hz ; Rated ripple current : 105°C, 120Hz.

105°C Use, Miniature, High-Ripple, Long Life Capacitors

GREEN CAP

105°C
10000hours

- Higher ripple current.
- Guarantees 5000 to 10000 hours at 105°C.
- Best-suited to electronic ballast.

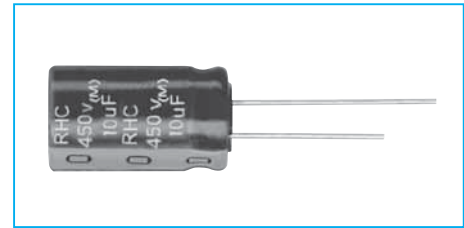
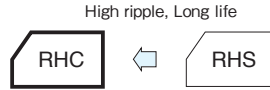

Marking color : White print on a black sleeve

Specifications

Item	Performance	
Category temperature range (°C)	-25 to +105	
Rated Voltage (V)	160 to 450	
Tolerance at rated capacitance (%)	±20 (20°C,120Hz)	
Leakage current (μA)	Less than 0.04CV + 100 (after 1 minutes) C : Rated capacitance (μF), V : Rated voltage (V) (20°C)	
Tangent of loss angle	Rated voltage (V)	160 to 250 350 to 450
	Tangent of loss angle	0.10 (0.15*) 0.12 (0.20*)
* The black circles in the capacitance column correspond. (20°C,120Hz)		
Characteristics at high and low temperature	Rated voltage (V)	160 to 250 350 to 450
	Impedance ratio Z-25°C/Z+20°C	3 6
(120Hz)		
Endurance (105°C) (Applied ripple current)	Test time	φ10×12.5 : 5000 hours φ10×16 to 20 : 8000 hours φ12.5 to 18 : 10000 hours
	Leakage current	The initial specific value or less
	Capacitance change	Within -30% to + 30% of initial value
	Tangent of loss angle	300% or less of the initial specified value
Shelf life (105°C)	Test time	1000 hours
	Leakage current	The initial specific value or less
	Capacitance change	Within -20% to + 20% of initial value
	Tangent of loss angle	200% or less of the initial specified value
Voltage application treatment		
Applicable standards	JIS C 5101-01, -04 1998 (IEC 60384-1 1992, 60384-4 1985)	

Outline Drawing

Unit : mm

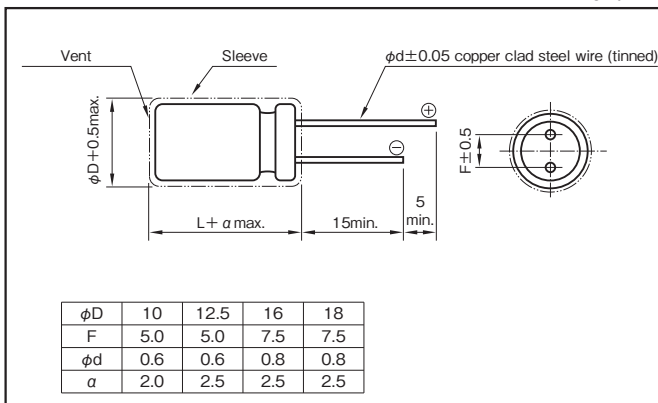

Coefficient of Frequency for Rated Ripple Current

Rated voltage (V)	Frequency (Hz)				
	50	120	1k	10k	100k
160 to 450	0.30	0.50	0.80	0.90	1.00

Part numbering system (example : 400V10μF)

RHC	—	400	V	100	M	H5	#	B	—	□
Series code		Rated voltage symbol		Rated capacitance symbol	Capacitance tolerance symbol	Casing symbol		Optional symbol		Taping(Forming) symbol

NOTE

Design, Specifications are subject to change without notice.
Ask factory for technical specifications before purchase and/or use.

Standard Ratings

Rated voltage(V)			160			200			250			350		
Case φD×L(mm)	Casing symbol	Item	Rated capacitance (μF)	ESR (Ω max.)	Rated ripple current (mArms)	Rated capacitance (μF)	ESR (Ω max.)	Rated ripple current (mArms)	Rated capacitance (μF)	ESR (Ω max.)	Rated ripple current (mArms)	Rated capacitance (μF)	ESR (Ω max.)	Rated ripple current (mArms)
10×12.5	H3		—	—	—	4.7	28	200	4.7	28	200	1.5	106	100
			—	—	—	—	—	—	—	—	—	2.2	72	140
			—	—	—	—	—	—	—	—	—	3.3	48	180
10×16	H4		10	13	320	6.8	20	220	6.8	20	250	4.7	34	220
			—	—	—	10	13	320	10	13	320	5.6	28	250
			—	—	—	—	—	—	● 22	9.0	450	—	—	—
10×20	H5		22	6.6	500	22	6.0	500	22	6.0	500	6.8	23	280
			33	4.0	650	33	4.0	650	—	—	—	10	16	350
			47	2.8	750	—	—	—	—	—	—	—	—	—
10×25	H6	—	—	—	—	—	—	33	4.0	720	—	—	—	
10×30	H7	—	—	—	—	—	—	47	2.8	880	—	—	—	
12.5×20	I5	68	2.0	1180	47	2.8	980	33	4.0	800	22	7.0	650	
12.5×25	I6	100	1.3	1420	68	2.0	1300	47	2.8	980	—	—	—	
12.5×30	I6	120	1.7	1500	—	—	—	—	—	—	—	—	—	
12.5×35	I8	—	—	—	—	—	—	100	1.3	1350	—	—	—	
16×20	J5		68	2.0	1180	68	2.0	1300	68	2.0	1300	33	4.8	900
			100	1.3	1420	100	1.3	1420	—	—	—	47	3.4	1080
16×25	J6	150	0.9	1890	150	0.9	1890	100	1.3	1530	68	3.9	1120	
16×31.5	J6	—	—	—	● 180	1.1	2200	—	—	—	—	—	—	
18×25	K6		220	0.6	2370	● 220	0.9	2380	150	0.9	1940	68	2.0	1470
			● 270	0.7	2470	—	—	—	—	—	—	—	—	—
18×31.5	K7	—	—	—	—	—	—	● 220	0.9	2200	● 100	2.7	1650	

Rated voltage(V)			400			450		
Case φD×L(mm)	Casing symbol	Item	Rated capacitance (μF)	ESR (Ω max.)	Rated ripple current (mArms)	Rated capacitance (μF)	ESR (Ω max.)	Rated ripple current (mArms)
10×12.5	H3		1	160	70	—	—	—
			1.5	107	100	—	—	—
			2.2	72	140	—	—	—
			● 3.3	80	160	—	—	—
10×16	H4		3.3	48	180	2.2	72	150
			4.7	34	220	3.3	48	180
			● 10	27	320	—	—	—
10×20	H5		5.6	28	250	4.7	34	220
			6.8	23	280	5.6	28	250
			10	16	350	6.8	23	280
			● 12	22	450	● 10	27	330
10×25	H6	● 18	15	290	—	—	—	
12.5×20	I5		15	11	550	10	16	450
			● 22	12	650	—	—	—
12.5×25	I6		22	7.2	760	15	11	600
			27	10	760	● 22	12	650
12.5×30	I7	33	8.0	720	—	—	—	
12.5×35	I8	47	5.6	960	● 33	8.0	800	
16×20	J5		22	7.2	760	22	7.2	730
			33	4.8	900	—	—	—
16×25	J6	47	3.4	1180	33	4.8	980	
18×25	K6	68	2.3	1470	47	3.4	1200	
18×31.5	K7		82	3.2	1600	● 68	3.9	1260
			100	2.7	1720	—	—	—
18×35.5	K8	—	—	—	● 100	2.7	1500	
18×40	K9	● 120	2.2	1945	● 120	2.2	1660	
18×45	KA	● 150	1.8	2215	—	—	—	
18×50	KB	—	—	—	● 150	1.8	2050	

(Note) ESR : 20°C , 120Hz ; Rated ripple current : 105°C , 100kHz

105°C Use, Miniature, High-Ripple, Long Life Capacitors

GREEN CAP

105°C
12000hours

- Higher ripple current.
- Guarantees 8000 to 12000 hours at 105°C.
- Best-suited to electronic ballast.

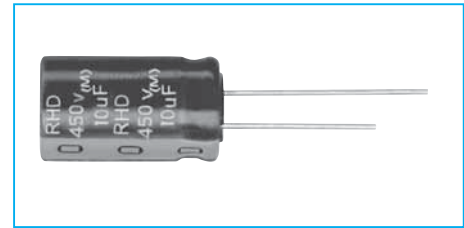
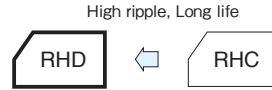

Marking color : White print on a black sleeve

Specifications

Item	Performance								
Category temperature range (°C)	-25 to +105								
Rated Voltage (V)	160 to 450								
Tolerance at rated capacitance (%)	±20 (20°C,120Hz)								
Leakage current(μA)	Less than 0.04CV + 100 (after 1 minutes) C:Rated capacitance (μF),V:Rated Voltage (V) (20°C)								
Tangent of loss angle	<table border="1"> <tr> <td>Rated voltage (V)</td> <td>160 to 250</td> <td>350 to 450</td> </tr> <tr> <td>Tangent of loss angle</td> <td>0.15</td> <td>0.20</td> </tr> </table>	Rated voltage (V)	160 to 250	350 to 450	Tangent of loss angle	0.15	0.20		
	Rated voltage (V)	160 to 250	350 to 450						
Tangent of loss angle	0.15	0.20							
	(20°C,120Hz)								
Characteristics at high and low temperature	<table border="1"> <tr> <td>Rated voltage (V)</td> <td>160 to 250</td> <td>350 to 450</td> </tr> <tr> <td>Impedance ratio Z-25°C/Z+20°C</td> <td>3</td> <td>6</td> </tr> </table>	Rated voltage (V)	160 to 250	350 to 450	Impedance ratio Z-25°C/Z+20°C	3	6		
	Rated voltage (V)	160 to 250	350 to 450						
Impedance ratio Z-25°C/Z+20°C	3	6							
	(120Hz)								
Endurance (105°C) (Applied ripple current)	<table border="1"> <tr> <td>Test time</td> <td>φ10×12.5L : 8000hours φ10×16,20L : 10000hours φ12.5 to 18 : 12000hours</td> </tr> <tr> <td>Leakage current</td> <td>The initial specified value or less</td> </tr> <tr> <td>Capacitance change</td> <td>Within -30% to +30% of initial value</td> </tr> <tr> <td>Tangent of loss angle</td> <td>300% or less of the initial specified value</td> </tr> </table>	Test time	φ10×12.5L : 8000hours φ10×16,20L : 10000hours φ12.5 to 18 : 12000hours	Leakage current	The initial specified value or less	Capacitance change	Within -30% to +30% of initial value	Tangent of loss angle	300% or less of the initial specified value
	Test time	φ10×12.5L : 8000hours φ10×16,20L : 10000hours φ12.5 to 18 : 12000hours							
	Leakage current	The initial specified value or less							
	Capacitance change	Within -30% to +30% of initial value							
Tangent of loss angle	300% or less of the initial specified value								
Shelf life (105°C)	<table border="1"> <tr> <td>Test time</td> <td>1000hours</td> </tr> <tr> <td>Leakage current</td> <td>The initial specified value or less</td> </tr> <tr> <td>Capacitance change</td> <td>Within -20% to +20% of initial value</td> </tr> <tr> <td>Tangent of loss angle</td> <td>200% or less of the initial specified value</td> </tr> </table>	Test time	1000hours	Leakage current	The initial specified value or less	Capacitance change	Within -20% to +20% of initial value	Tangent of loss angle	200% or less of the initial specified value
	Test time	1000hours							
	Leakage current	The initial specified value or less							
	Capacitance change	Within -20% to +20% of initial value							
Tangent of loss angle	200% or less of the initial specified value								
	Voltage application treatment								
Applicable Standards	JIS C 5101-01, -04 1998 (IEC 60384-1 1992,60384-4 1985)								

Outline Drawing

Unit : mm

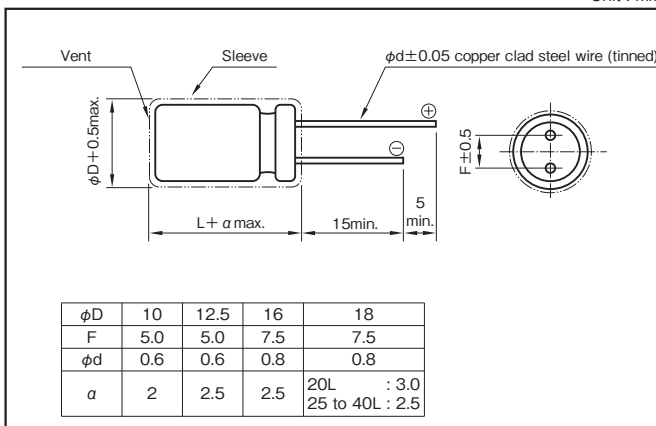

Coefficient of Frequency for Rated Ripple Current

Rated voltage (V)	Frequency (Hz)				
	50	120	1k	10k	100k
160 to 450	0.30	0.50	0.80	0.90	1.00

Part numbering system (example : 400V47μF)

RHD	—	400	V	470	M	K6	#	B	—	□
Series code		Rated voltage symbol		Rated capacitance symbol	Capacitance tolerance symbol	Casing symbol		Optional symbol		Taping(Forming) symbol

Standard Ratings

Rated voltage(V)			160			200			250			350		
Case φD×L(mm)	Casing symbol	Item	Rated capacitance (μF)	ESR (Ω max.)	Rated ripple current (mArms)	Rated capacitance (μF)	ESR (Ω max.)	Rated ripple current (mArms)	Rated capacitance (μF)	ESR (Ω max.)	Rated ripple current (mArms)	Rated capacitance (μF)	ESR (Ω max.)	Rated ripple current (mArms)
10×12.5	H3		—	—	—	10	20	250	6.8	29	250	4.7	56	200
10×16	H4		10	20	250	10	20	250	—	—	—	6.8	39	220
10×20	H5		22	9.0	500	22	9.0	500	10	20	280	10	27	280
			33	6.0	500	33	6.0	600	—	—	—	—	—	—
10×25	H6		—	—	—	47	4.2	660	—	—	—	—	—	—
10×30	H7		—	—	—	56	3.5	700	—	—	—	—	—	—
12.5×20	I5		47	4.2	660	33	6.0	600	22	9.0	600	22	12	350
			—	—	—	47	4.2	660	33	6.0	600	—	—	—
12.5×25	I6		68	2.9	760	68	2.9	760	47	4.2	720	—	—	—
12.5×30	I7		—	—	—	—	—	—	—	—	—	47	5.6	425
16×20	J5		68	2.9	760	68	2.9	760	47	4.2	720	33	8.0	500
16×25	J6		100	2.0	1120	100	2.0	1120	68	2.9	920	47	5.6	660
16×31.5	J7		150	1.3	1360	150	1.3	1360	100	2.0	1200	68	3.9	850
			220	0.9	1400	—	—	—	—	—	—	—	—	—
18×20	K5		100	2.0	1120	100	2.0	1120	68	2.9	920	47	5.6	660
			150	1.3	1360	150	1.3	1360	100	2.0	1200	68	3.9	850
18×25	K6		220	0.9	1400	220	0.9	1400	—	—	—	—	—	—
			330	0.6	2580	220	0.9	1700	150	1.3	1500	100	2.6	1420
18×35.5	K8		—	—	—	—	—	—	—	—	—	150	1.7	2115

Rated voltage(V)			400			450		
Case φD×L(mm)	Casing symbol	Item	Rated capacitance (μF)	ESR (Ω max.)	Rated ripple current (mArms)	Rated capacitance (μF)	ESR (Ω max.)	Rated ripple current (mArms)
10×16	H4		3.3	80	200	4.7	56	130
			6.8	39	220	6.8	39	140
10×20	H5		10	27	280	4.7	56	140
			—	—	—	6.8	39	150
10×25	H6		—	—	—	10	27	280
12.5×20	I5		18	14	500	15	18	380
			—	—	—	10	27	320
12.5×25	I6		—	—	—	15	18	380
12.5×30	I7		22	12	430	22	12	430
12.5×40	I9		47	5.6	910	—	—	—
16×20	J5		—	—	—	47	5.6	880
16×25	J6		22	12	430	—	—	—
			33	8.0	640	22	12	560
16×31.5	J7		47	5.6	840	—	—	—
16×40	J9		47	5.6	840	33	8.0	700
18×20	K5		100	2.6	1510	—	—	—
18×25	K6		33	8.0	640	22	12	560
			47	5.6	840	33	8.0	700
18×31.5	K7		—	—	—	56	4.7	800
			68	3.9	1000	47	5.6	880
18×35.5	K8		82	3.2	1280	—	—	—
			100	2.6	1640	68	3.9	1130
18×40	K9		—	—	—	82	3.2	1200
18×45	KA		120	2.2	1740	100	2.6	1670
			150	1.7	1970	—	—	—

(Note) ESR : 20°C , 120Hz ; Rated ripple current : 105°C , 100kHz

125°C Use, Miniature, Low Impedance

GREEN CAP

Low Z

125°C
5000hours

Anti-
cleaning
solvent

- Smaller and low impedance than RK series.
- Guarantees 5000 hours at 125°C ($\phi 8$: 2000h, $\phi 10$: 3000h)

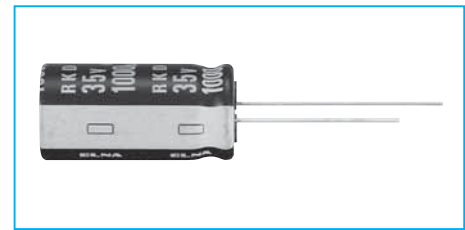

Marking color : White print on a black sleeve

Specifications

Item	Performance																		
Category temperature range (°C)	-40 to +125																		
Tolerance at rated capacitance (%)	±20 (20°C, 120Hz)																		
Leakage current (μA)	Less than 0.01CV or 4 whichever is larger (after 2 minute) C : Rated capacitance (μF), V : Rated voltage (V) (20°C)																		
Tangent of loss angle (tanδ)	<table border="1"> <thead> <tr> <th>Rated voltage (V)</th> <th>10</th> <th>16</th> <th>25</th> <th>35</th> <th>50</th> <th>63</th> <th>80</th> <th>100</th> </tr> </thead> <tbody> <tr> <td>tanδ (max.)</td> <td>0.20</td> <td>0.16</td> <td>0.14</td> <td>0.12</td> <td>0.10</td> <td>0.10</td> <td>0.08</td> <td>0.08</td> </tr> </tbody> </table>	Rated voltage (V)	10	16	25	35	50	63	80	100	tanδ (max.)	0.20	0.16	0.14	0.12	0.10	0.10	0.08	0.08
	Rated voltage (V)	10	16	25	35	50	63	80	100										
tanδ (max.)	0.20	0.16	0.14	0.12	0.10	0.10	0.08	0.08											
0.02 is added to every 1000μF increase over 1000μF. (20°C, 120Hz)																			
Characteristics at high and low temperature	<table border="1"> <thead> <tr> <th>Rated voltage (V)</th> <th>10</th> <th>16</th> <th>25</th> <th>35</th> <th>50</th> <th>63</th> <th>80</th> <th>100</th> </tr> </thead> <tbody> <tr> <td>Impedance ratio (max.)</td> <td>Z-40°C/Z+20°C</td> <td>4</td> <td>3</td> <td>3</td> <td>3</td> <td>3</td> <td>3</td> <td>3</td> </tr> </tbody> </table>	Rated voltage (V)	10	16	25	35	50	63	80	100	Impedance ratio (max.)	Z-40°C/Z+20°C	4	3	3	3	3	3	3
	Rated voltage (V)	10	16	25	35	50	63	80	100										
Impedance ratio (max.)	Z-40°C/Z+20°C	4	3	3	3	3	3	3											
(120Hz)																			
Endurance (125°C) (Applied ripple current)	Test time	5000 hours ($\phi 8$: 2000 hours) ($\phi 10$: 3000 hours)																	
	Leakage current	The initial specified value or less																	
	Percentage of capacitance change	Within -30% to +30% of initial value																	
	Tangent of the loss angle	300% or less of the initial specified value																	
Shelf life (125°C)	Test time : 1000 hours; other items are the same as those for the endurance. Voltage application treatment																		
Applicable standards	JIS C5101-1, -4 1998 (IEC 60384-1 1992, -4 1985)																		

Outline Drawing

Unit : mm

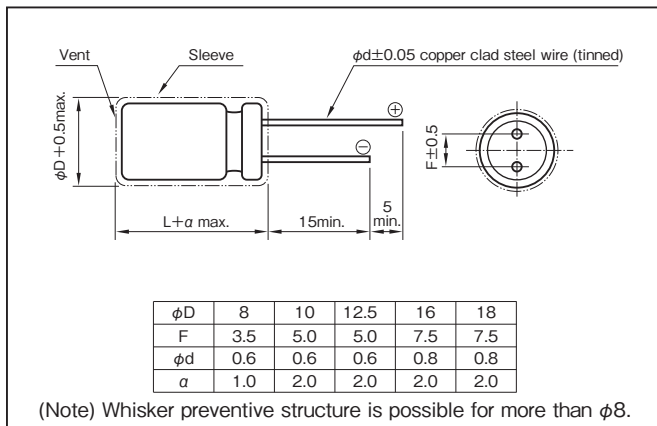

Coefficient of Frequency for Rated Ripple Current

Rated capacitance (μF)	Frequency (Hz)			
	50 · 60	120	1k	10k · 100k
100 to 180	0.40	0.75	0.90	1
220 to 390	0.50	0.85	0.95	1
470 to 1800	0.60	0.88	0.96	1
2200 to 6800	0.68	0.90	0.98	1

Part numbering system (example : 10V1000μF)

RKD	—	10	V	102	M	H5	#	—	□
Series code		Rated voltage symbol		Rated capacitance symbol	Capacitance tolerance symbol	Casing symbol			Taping(Forming) symbol

If it is whisker preventive structure, should change "#" into "G".

Standard Ratings

Rated voltage (V)	Item	10				16				25				35			
		Case φD×L (mm)	Casing symbol	Impedance (Ω max.)	Rated ripple current (mArms)	Case φD×L (mm)	Casing symbol	Impedance (Ω max.)	Rated ripple current (mArms)	Case φD×L (mm)	Casing symbol	Impedance (Ω max.)	Rated ripple current (mArms)	Case φD×L (mm)	Casing symbol	Impedance (Ω max.)	Rated ripple current (mArms)
100	—	—	—	—	8×12	G3	0.153	500	8×12	G3	0.153	500	8×12	G3	0.153	500	
220	8×12	G3	0.153	500	8×12	G3	0.153	500	8×12	G3	0.153	500	10×12.5	H3	0.098	725	
					10×12.5	H3	0.098	725	10×12.5	H3	0.098	725	10×16	H4	0.075	951	
330	8×12	G3	0.153	500	8×12	G3	0.153	500	10×12.5	H3	0.098	725	10×16	H4	0.075	951	
	10×12.5	H3	0.098	725	10×12.5	H3	0.098	725	10×16	H4	0.075	951	10×20	H5	0.057	1130	
470	10×12.5	H3	0.098	725	10×16	H4	0.075	951	10×16	H4	0.075	951	10×20	H5	0.057	1130	
									10×20	H5	0.057	1130	12.5×20	I5	0.040	1550	
									12.5×25	I6	0.032	1880	16×16	J4	0.044	1600	
1000	10×20	H5	0.057	1130	10×20	H5	0.057	1130	12.5×20	I5	0.040	1550	12.5×25	I6	0.032	1880	
	12.5×15	I4	0.059	1150	12.5×20	I5	0.040	1550	12.5×25	I6	0.032	1880	16×25	J6	0.024	2550	
					16×16	J4	0.044	1600	16×16	J4	0.044	1600	18×20	K5	0.029	2320	
1200	—	—	—	—	—	—	—	—	12.5×20	I5	0.040	1550	12.5×30	I7	0.029	2160	
													16×20	J5	0.032	2020	
1500	—	—	—	—	—	—	—	—	—	—	—	—	12.5×35	I8	0.023	2580	
													16×31.5	J7	0.020	3040	
													18×25	K6	0.022	2880	
1800	—	—	—	—	—	—	—	—	12.5×25	I6	0.032	1880	12.5×40	I9	0.020	2920	
									16×20	J5	0.032	2020	16×25	J6	0.024	2550	
2200	12.5×25	I6	0.032	1880	12.5×25	I6	0.032	1880	12.5×30	I7	0.029	2160	16×31.5	J7	0.020	3040	
	16×20	J5	0.032	2020	16×25	J6	0.024	2550	16×25	J6	0.024	2550	16×35.5	J8	0.019	3280	
	18×16	K4	0.041	1800	18×20	K5	0.029	2320	18×20	K5	0.029	2320	18×25	K6	0.022	2880	
2700	—	—	—	—	—	—	—	—	12.5×35	I8	0.023	2580	16×35.5	J8	0.019	3280	
									16×25	J6	0.024	2550	18×31.5	K7	0.018	3410	
									18×20	K5	0.029	2320	18×31.5	K7	0.018	3410	
3300	16×25	J6	0.024	2550	16×31.5	J7	0.020	3040	12.5×40	I9	0.020	2920	16×40	J9	0.017	3630	
	18×20	K5	0.029	2320	18×25	K6	0.022	2880	16×31.5	J7	0.020	3040	18×35.5	K8	0.017	3710	
									16×31.5	J7	0.020	3040	18×35.5	K8	0.017	3710	
3900	—	—	—	—	—	—	—	—	16×35.5	J8	0.019	3280	—	—	—	—	
									18×25	K6	0.022	2880	—	—	—	—	
4700	16×31.5	J7	0.020	3040	16×35.5	J8	0.019	3280	18×35.5	K8	0.017	3710	18×40	K9	0.016	4000	
	18×25	K6	0.022	2880	18×31.5	K7	0.018	3410	18×31.5	K7	0.018	3410	—	—	—	—	
5600	—	—	—	—	—	—	—	—	16×40	J9	0.017	3630	—	—	—	—	
									18×35.5	K8	0.017	3710	—	—	—	—	
6800	—	—	—	—	—	—	—	—	18×40	K9	0.016	4000	—	—	—	—	

Rated voltage (V)	Item	50				63				80				100			
		Case φD×L (mm)	Casing symbol	Impedance (Ω max.)	Rated ripple current (mArms)	Case φD×L (mm)	Casing symbol	Impedance (Ω max.)	Rated ripple current (mArms)	Case φD×L (mm)	Casing symbol	Impedance (Ω max.)	Rated ripple current (mArms)	Case φD×L (mm)	Casing symbol	Impedance (Ω max.)	Rated ripple current (mArms)
220	10×20	—	0.098	930	—	—	—	—	—	—	—	—	16×20	J5	0.131	1070	
330	—	—	—	—	—	—	—	—	16×20	J5	0.131	1070	16×25	J6	0.097	1350	
470	12.5×20	I5	0.070	1170	16×20	J5	0.099	1230	16×25	J6	0.097	1350	16×35.5	J8	0.077	1740	
560	—	—	—	—	—	—	—	—	18×25	K6	0.088	1530	16×40	J9	0.069	1940	
820	12.5×30	I7	0.047	1680	16×31.5	J7	0.062	1850	18×35.5	K8	0.069	1980	18×40	K9	0.066	2120	
1000	16×25	J6	0.039	1990	16×35.5	J8	0.058	2010	18×40	K9	0.066	2120	—	—	—	—	
1800	18×31.5	K7	0.030	2670	18×40	K9	0.053	2350	—	—	—	—	—	—	—	—	
2200	18×35.5	K8	0.028	2900	—	—	—	—	—	—	—	—	—	—	—	—	

(Note) Rated ripple current : 125°C , 100kHz, Impedance : 20°C , 100kHz

125°C Use, Long Life Capacitors

GREEN CAP	Low Impedance	125°C 5000hours	Anti-cleaning solvent
-----------	---------------	-----------------	-----------------------

- Guarantees 5000 hours at 125°C.
- Best-suited to smoothing circuits and control circuits for industrial equipment power supplies of which long life and high reliability are required.
- NC terminal added items are lineup for vibration resistance.

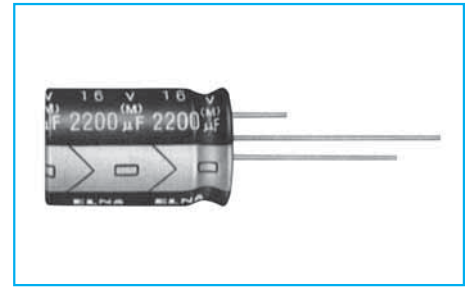

Marking color : White print on a black sleeve

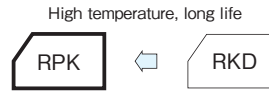

Specifications

Item	Performance																		
Category temperature range (°C)	-40 to +125																		
Tolerance at rated capacitance (%)	±20 (20°C, 120Hz)																		
Leakage current (μA)	Less than 0.01CV or 4 whichever is larger (after 2 minutes) C : Rated capacitance (μF), V : Rated voltage (V) (20°C)																		
Tangent of loss angle (tanδ)	<table border="1"> <tr> <td>Rated voltage (V)</td> <td>10</td> <td>16</td> <td>25</td> <td>35</td> <td>50</td> <td>63</td> <td>80</td> <td>100</td> </tr> <tr> <td>tanδ (max.)</td> <td>0.20</td> <td>0.16</td> <td>0.14</td> <td>0.12</td> <td>0.10</td> <td>0.10</td> <td>0.08</td> <td>0.08</td> </tr> </table>	Rated voltage (V)	10	16	25	35	50	63	80	100	tanδ (max.)	0.20	0.16	0.14	0.12	0.10	0.10	0.08	0.08
	Rated voltage (V)	10	16	25	35	50	63	80	100										
tanδ (max.)	0.20	0.16	0.14	0.12	0.10	0.10	0.08	0.08											
0.02 is added to every 1000μF increase over 1000μF. (20°C, 120Hz)																			
Characteristics at high and low temperature	<table border="1"> <tr> <td>Rated voltage (V)</td> <td>10</td> <td>16</td> <td>25</td> <td>35</td> <td>50</td> <td>63</td> <td>80</td> <td>100</td> </tr> <tr> <td>Impedance ratio (max.)</td> <td>Z-40°C/Z+20°C</td> <td>4</td> <td>3</td> <td>3</td> <td>3</td> <td>3</td> <td>3</td> <td>3</td> </tr> </table>	Rated voltage (V)	10	16	25	35	50	63	80	100	Impedance ratio (max.)	Z-40°C/Z+20°C	4	3	3	3	3	3	3
	Rated voltage (V)	10	16	25	35	50	63	80	100										
Impedance ratio (max.)	Z-40°C/Z+20°C	4	3	3	3	3	3	3											
(120Hz)																			
Endurance (125°C) (Applied ripple current)	Test time	5000 hours																	
	Leakage current	The initial specified value or less																	
	Percentage of capacitance change	Within -30% to +30% of initial value																	
	Tangent of the loss angle	300% or less of the initial specified value																	
Shelf life (125°C)	Test time :1000 hours; other items are the same as those for the endurance. Voltage application treatment																		
Applicable standards	JIS C5101-1, -4 1998 (IEC 60384-1 1992, -4 1985)																		

Outline Drawing

Unit : mm

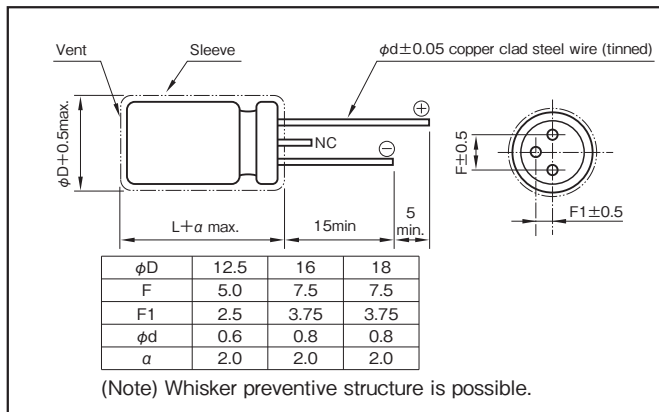

Coefficient of Frequency for Rated Ripple Current

Rated capacitance (μF)	Frequency (Hz)			
	120	1k	10k	100k
220 to 330	0.50	0.85	0.95	1
470 to 1000	0.60	0.88	0.96	1
2200 to 6800	0.68	0.90	0.98	1

Part numbering system

RPK series 16V220μF

RPK	—	16	V	222	M	J6	D#	—	□
Series code		Rated voltage symbol		Rated capacitance symbol	Capacitance tolerance symbol	Casing symbol			Taping(Forming) symbol

If it is whisker preventive structure, should change “#” into “G”.

Standard Ratings

Rated voltage (V)	Item	10				16				25				35			
		Case	Casing symbol	Impedance	Rated ripple current	Case	Casing symbol	Impedance	Rated ripple current	Case	Casing symbol	Impedance	Rated ripple current	Case	Casing symbol	Impedance	Rated ripple current
		φD×L (mm)		(Ω max.)	(mArms)	φD×L (mm)		(Ω max.)	(mArms)	φD×L (mm)		(Ω max.)	(mArms)	φD×L (mm)		(Ω max.)	(mArms)
470	—	—	—	—	—	—	—	—	—	—	—	—	—	12.5×20	I5	0.040	1550
														16×16	J4	0.044	1600
1000	12.5×15	I4	0.059	1150	12.5×20	I5	0.040	1550	12.5×20	I5	0.040	1550	12.5×25	I6	0.032	1880	
					16×16	J4	0.044	1600	12.5×25	I6	0.032	1880	16×25	J6	0.024	2550	
									16×16	J4	0.044	1600	18×20	K5	0.029	2320	
1200	—	—	—	—	—	—	—	—	12.5×20	I5	0.040	1550	12.5×30	I7	0.029	2160	
													16×20	J5	0.032	2020	
1500	—	—	—	—	—	—	—	—	—	—	—	—	12.5×35	I8	0.023	2580	
													16×31.5	J7	0.020	3040	
													18×25	K6	0.022	2880	
1800	—	—	—	—	—	—	—	—	12.5×25	I6	0.032	1880	12.5×40	I9	0.020	2920	
									16×20	J5	0.032	2020	16×25	J6	0.024	2550	
													16×35.5	J8	0.019	3280	
									12.5×30	I7	0.029	2160	16×31.5	J7	0.020	3040	
					12.5×25	I6	0.032	1880	16×25	J6	0.024	2550	18×25	K6	0.022	2880	
					16×20	J5	0.032	2020	18×20	K5	0.029	2320	16×35.5	J8	0.019	3280	
					18×20	K5	0.029	2320	12.5×35	I8	0.023	2580	16×35.5	J8	0.019	3280	
									16×25	J6	0.024	2550	18×31.5	K7	0.018	3410	
									18×20	K5	0.029	2320	16×40	J9	0.017	3630	
									12.5×40	I9	0.020	2920	18×35.5	K8	0.017	3710	
					16×25	J6	0.024	2550	16×31.5	J7	0.020	3040	—	—	—	—	
					18×20	K5	0.029	2320	16×31.5	J7	0.020	3040	—	—	—	—	
					18×25	K6	0.022	2880	16×35.5	J8	0.019	3280	—	—	—	—	
									18×25	K6	0.022	2880	—	—	—	—	
									18×35.5	K8	0.017	3710	18×40	K9	0.016	4000	
					16×31.5	J7	0.020	3040	18×31.5	K7	0.018	3410	—	—	—	—	
					18×20	K5	0.029	2320	16×40	J9	0.017	3630	—	—	—	—	
					18×25	K6	0.022	2880	18×35.5	K8	0.017	3710	—	—	—	—	
									16×40	J9	0.017	3630	—	—	—	—	
									18×35.5	K8	0.017	3710	—	—	—	—	
									18×40	K9	0.016	4000	—	—	—	—	

Rated voltage (V)	Item	50				63				80				100			
		Case	Casing symbol	Impedance	Rated ripple current	Case	Casing symbol	Impedance	Rated ripple current	Case	Casing symbol	Impedance	Rated ripple current	Case	Casing symbol	Impedance	Rated ripple current
		φD×L (mm)		(Ω max.)	(mArms)	φD×L (mm)		(Ω max.)	(mArms)	φD×L (mm)		(Ω max.)	(mArms)	φD×L (mm)		(Ω max.)	(mArms)
220	—	—	—	—	—	—	—	—	—	—	—	—	16×20	J5	0.131	1070	
330	—	—	—	—	—	—	—	—	16×20	J5	0.131	1070	16×25	J6	0.097	1350	
470	12.5×20	I5	0.070	1170	16×20	J5	0.099	1230	16×25	J6	0.097	1350	16×35.5	J8	0.077	1740	
560	—	—	—	—	—	—	—	—	18×25	K6	0.088	1530	16×40	J9	0.069	1940	
820	12.5×30	I7	0.047	1680	16×31.5	J7	0.062	1850	18×35.5	K8	0.069	1980	18×40	K9	0.066	2120	
1000	16×25	J6	0.039	1990	16×35.5	J8	0.058	2010	18×40	K9	0.066	2120	—	—	—	—	
1800	18×31.5	K7	0.030	2670	18×40	K9	0.053	2350	—	—	—	—	—	—	—	—	
2200	18×35.5	K8	0.028	2900	—	—	—	—	—	—	—	—	—	—	—	—	

(Note) Rated ripple current : 125°C, 100kHz , Impedance : 20°C, 100kHz

150°C Use, Miniature, Low Impedance

GREEN CAP

Low Z

150°C
1000hours

Anti-cleaning solvent

- 150°C, High temperature guaranteed.
- Guarantees 1000 hours at 150°C.



High temperature

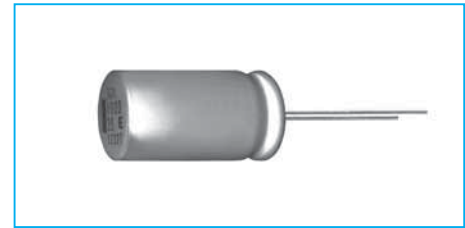

Marking color : Black print

Specifications

Item	Performance				
Category temperature range (°C)	-40 to +150				
Tolerance at rated capacitance (%)	±20 (20°C, 120Hz)				
Leakage current (µA)	Less than 0.01CV or 4 whichever is larger (after 2 minute) C : Rated capacitance (µF), V : Rated voltage (V) (20°C)				
Tangent of loss angle (tanδ)	Rated voltage (V)	10	16	25	35
	tanδ (max.)	0.20	0.16	0.14	0.12
0.02 is added to every 1000µF increase over 1000µF. (20°C, 120Hz)					
Characteristics at high and low temperature	Rated voltage (V)	10	16	25	35
	Impedance ratio (max.)	Z-40°C/Z+20°C	4	3	3
(120Hz)					
Endurance (150°C) (Applied ripple current)	Test time	1000 hours			
	Leakage current	The initial specified value or less			
	Percentage of capacitance change	Within -30% to +30% of initial value			
	Tangent of the loss angle	300% or less of the initial specified value			
Shelf life (150°C)					
Applicable standards	JIS C5101-1, -4 1998 (IEC 60384-1 1992, -4 1985)				

Outline Drawing

Unit : mm

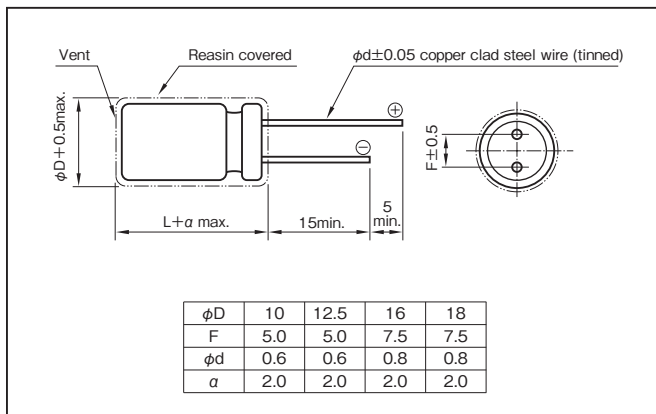

Coefficient of Frequency for Rated Ripple Current

Frequency (Hz)				
220 to 330				
470 to 1000				
2200 to 10000				

Part numbering system (example : 35V1000µF)

RQA	—	35	V	102	M	I 6	—	
Series code		Rated voltage symbol		Rated capacitance symbol	Capacitance tolerance symbol	Casing symbol		Taping(Forming) symbol

Standard Ratings

Rated voltage (V)	Item	10			16			25			35		
		Case	Casing symbol	Rated ripple current (mArms)	Case	Casing symbol	Rated ripple current (mArms)	Case	Casing symbol	Rated ripple current (mArms)	Case	Casing symbol	Rated ripple current (mArms)
Rated capacitance (µF)	φD×L (mm)			φD×L (mm)			φD×L (mm)			φD×L (mm)			
220	—	—	—	—	—	—	10×14	H3	510	10×14	H3	510	
330	—	—	—	—	—	—	10×17	H3	660	10×17	H4	660	
470	—	—	—	10×17	H4	510	10×22	H5	820	10×22	H5	820	
1000	10×22	H5	820	10×22	H5	820	12.5×27	I6	1200	12.5×27	I6	1200	
2200	12.5×22	I5	1000	12.5×27	I6	1000	16×27	J6	1370	16×27	J6	1370	
3300	12.5×22	I5	1280	16×27	J6	1200	16×37.5	J8	1720	18×33.5	K7	1670	
4700	16×27	J6	1370	16×33.5	J7	1370	18×37.5	K8	1790	18×42	K9	1870	
10000	18×37.5	K8	1790	—	—	—	—	—	—	—	—	—	

(Note) Rated ripple current : 150°C , 100kHz

NOTE

Design, Specifications are subject to change without notice.
Ask factory for technical specifications before purchase and/or use.

135°C Use, Miniature, Low Impedance

GREEN CAP Low Z 135°C 3000hours Anti-cleaning solvent

- High temperature guaranteed and low ESR series for automotive.
- Guarantees 3000 hours at 135°C. (φ10 : 2000 hours)

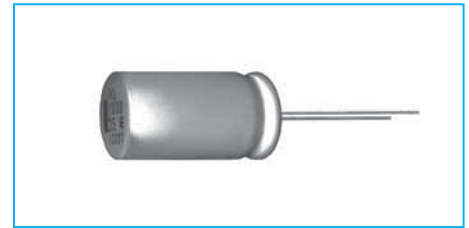
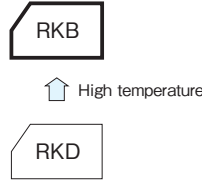

Marking color : Black print

Specifications

Item	Performance										
Category temperature range (°C)	-40 to +135										
Tolerance at rated capacitance (%)	±20 (20°C, 120Hz)										
Leakage current (μA)	Less than 0.01CV or 4 whichever is larger (after 2 minute) C : Rated capacitance (μF), V : Rated voltage (V) (20°C)										
Tangent of loss angle (tanδ)	<table border="1"> <tr> <th>Rated voltage (V)</th> <td>10</td> <td>16</td> <td>25</td> <td>35</td> </tr> <tr> <th>tanδ (max.)</th> <td>0.20</td> <td>0.16</td> <td>0.14</td> <td>0.12</td> </tr> </table>	Rated voltage (V)	10	16	25	35	tanδ (max.)	0.20	0.16	0.14	0.12
	Rated voltage (V)	10	16	25	35						
tanδ (max.)	0.20	0.16	0.14	0.12							
0.02 is added to every 1000μF increase over 1000μF. (20°C, 120Hz)											
Characteristics at high and low temperature	<table border="1"> <tr> <th>Rated voltage (V)</th> <td>10</td> <td>16</td> <td>25</td> <td>35</td> </tr> <tr> <th>Impedance ratio (max.)</th> <td>Z-40°C/Z+20°C</td> <td>4</td> <td>3</td> <td>3</td> </tr> </table>	Rated voltage (V)	10	16	25	35	Impedance ratio (max.)	Z-40°C/Z+20°C	4	3	3
	Rated voltage (V)	10	16	25	35						
Impedance ratio (max.)	Z-40°C/Z+20°C	4	3	3							
(120Hz)											
Endurance (135°C) (Applied ripple current)	Test time	3000 hours (φ10 : 2000 hours)									
	Leakage current	The initial specified value or less									
	Percentage of capacitance change	Within -30% to +30% of initial value									
	Tangent of the loss angle	300% or less of the initial specified value									
Shelf life (135°C)	Test time : 1000 hours; other items are the same as those for the endurance. Voltage application treatment										
Applicable standards	JIS C5101-1, -4 1998 (IEC 60384-1 1992, -4 1985)										

Outline Drawing

Unit : mm

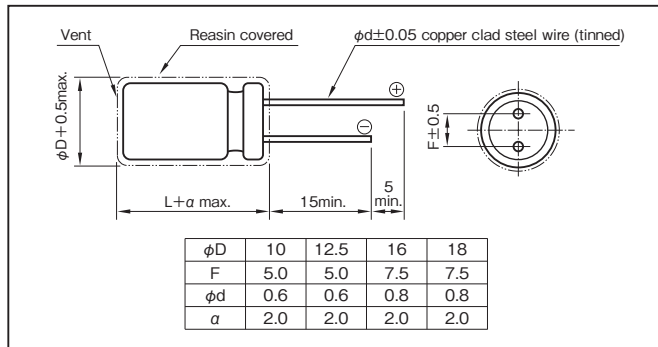

Coefficient of Frequency for Rated Ripple Current

Rated capacitance (μF) \ Frequency (Hz)	50 · 60	120	1k	10k · 100k
220 to 330	0.50	0.85	0.95	1
470 to 1000	0.60	0.88	0.96	1
1200 to 6800	0.68	0.90	0.98	1

Part numbering system (example : 10V1000μF)

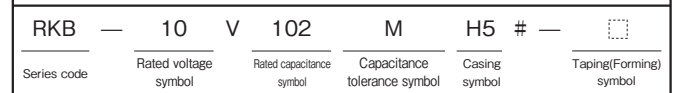

Standard Ratings

Rated voltage (V) \ Rated capacitance (μF)	10				16				25				35			
	Case φD×L (mm)	Casing symbol	ESR (Ω max.)	Rated ripple current (mA rms)	Case φD×L (mm)	Casing symbol	ESR (Ω max.)	Rated ripple current (mA rms)	Case φD×L (mm)	Casing symbol	ESR (Ω max.)	Rated ripple current (mA rms)	Case φD×L (mm)	Casing symbol	ESR (Ω max.)	Rated ripple current (mA rms)
220	—	—	—	—	10×12.5	H3	0.098	725	10×12.5	H3	0.098	725	10×12.5	H3	0.098	725
330	10×12.5	H3	0.098	725	10×12.5	H3	0.098	725	10×12.5	H3	0.098	725	10×16	H4	0.075	951
	10×16	H4	0.075	951	10×16	H4	0.075	951	10×16	H4	0.075	951	10×20	H5	0.057	1130
470	10×12.5	H3	0.098	725	10×16	H4	0.075	951	10×16	H4	0.075	951	10×20	H5	0.057	1130
	10×20	H5	0.057	1130	10×20	H5	0.057	1130	10×20	H5	0.057	1130	12.5×20	I5	0.040	1550
1000	12.5×15	I4	0.059	1130	12.5×20	I5	0.040	1550	12.5×20	I5	0.040	1550	12.5×25	I6	0.032	1880
	12.5×25	I6	0.032	1880	12.5×25	I6	0.032	1880	12.5×25	I6	0.032	1880	16×25	J6	0.024	2550
1200	—	—	—	—	—	—	—	—	12.5×20	I5	0.040	1550	12.5×30	I7	0.029	2160
	—	—	—	—	—	—	—	—	16×20	J5	0.032	2020	16×20	J5	0.032	2020
1500	—	—	—	—	—	—	—	—	—	—	—	—	12.5×35	I8	0.023	2580
	—	—	—	—	—	—	—	—	—	—	—	—	16×31.5	J7	0.020	3040
1800	—	—	—	—	—	—	—	—	12.5×25	I6	0.032	1880	12.5×40	I9	0.020	2920
	—	—	—	—	—	—	—	—	16×20	J5	0.032	2020	16×25	J6	0.024	2550
2200	12.5×25	I6	0.032	1880	12.5×25	I6	0.032	1880	12.5×30	I7	0.029	2160	16×31.5	J7	0.020	3040
	16×20	J5	0.032	2020	16×25	J6	0.024	2550	16×25	J6	0.024	2550	16×35.5	J8	0.019	3280
2700	—	—	—	—	—	—	—	—	12.5×35	I8	0.023	2580	16×35.5	J8	0.019	3280
	—	—	—	—	—	—	—	—	16×25	J6	0.024	2550	18×31.5	K7	0.018	3410
3300	16×25	J6	0.024	2550	16×31.5	J7	0.020	3040	12.5×40	I9	0.020	2920	16×40	J9	0.017	3630
	18×20	K5	0.029	2320	18×25	K6	0.022	2880	16×31.5	J7	0.020	3040	18×35.5	K8	0.017	3710
4700	16×31.5	J7	0.020	3040	16×35.5	J8	0.019	3280	16×35.5	J8	0.019	3280	18×40	K9	0.016	4000
	18×25	K6	0.022	2880	18×31.5	K7	0.018	3410	18×31.5	J7	0.018	3410	—	—	—	—
5600	—	—	—	—	—	—	—	—	16×40	J9	0.017	3630	—	—	—	—
6800	—	—	—	—	—	—	—	—	18×40	K9	0.016	4000	—	—	—	—

(Note) Rated ripple current : 135°C , 100kHz, ESR : 20°C , 100kHz

NOTE

Design, Specifications are subject to change without notice. Ask factory for technical specifications before purchase and/or use.

Low Leakage Current Capacitors

GREEN
CAP

- Low leakage current (after 1 minute) : 0.006CV or 0.5 (μA).



Marking color : White print on a blue sleeve

Specifications

Item	Performance	
Category temperature range (°C)	-40 to +85	
Tolerance at rated capacitance (%)	±20 (20°C, 120Hz)	
Leakage current (μA)	Less than 0.006CV or 0.5 whichever is larger (after 1 minute) Less than 0.002CV or 0.3 whichever is larger (after 2 minutes), C : Rated capacitance (μF) ; V : Rated voltage (V) (20°C)	
Tangent of loss angle (tanδ)	Rated voltage (V)	6.3 10 16 25 35 50
	tanδ (max.)	More than 1μF 0.20 0.17 0.13 0.10 0.10 0.08 1μF or less 0.06 0.06 0.06 0.06 0.06 0.06
Characteristics at high and low temperature	Rated voltage (V)	6.3 10 16 25 35 50
	Impedance ratio (max.)	Z-25°C/Z+20°C 4 3 2 2 2 2 Z-40°C/Z+20°C 8 6 4 4 3 3
Endurance (85°C) (Applied ripple current)	Test time	1000 hours
	Leakage current	The initial specified value or less
	Percentage of capacitance change	Within ±20% of initial value
	Tangent of the loss angle	150% or less of the initial specified value
Shelf life (85°C)	Test time : 1000 hours ; other items are the same as those for the endurance. Voltage application treatment	
Applicable standards	JIS C5101-1, -4 1998 (IEC 60384-1 1992, -4 1985)	

Outline Drawing

Unit : mm

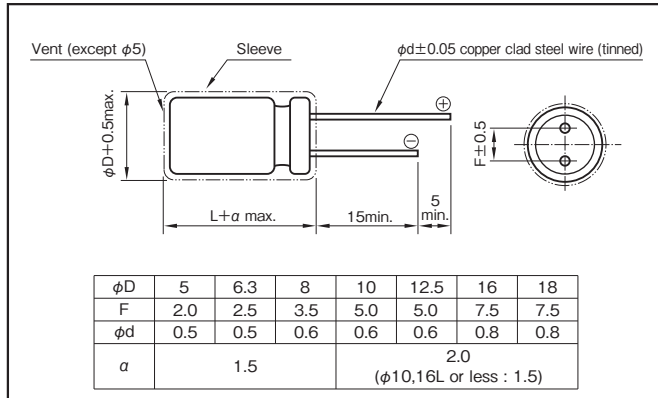

Coefficient of Frequency for Rated Ripple Current

Rated voltage (V)	Frequency (Hz) CV (μF×V)	50 · 60	120	1k	10k · 100k
		6.3 to 10	All CV value	0.8	1
16 to 25	≤1000	0.8	1	1.5	1.7
	1000<	0.8	1	1.2	1.3
35 to 50	All CV value	0.8	1	1.6	1.9

Part numbering system (example : 10V1000μF)

RLB	—	10	V	102	M	I6	#	—	□
Series code		Rated voltage symbol		Rated capacitance symbol	Capacitance tolerance symbol	Casing symbol			Taping(Forming) symbol

Casing symbol

Case φD×L (mm)	Casing symbol	Case φD×L (mm)	Casing symbol	Case φD×L (mm)	Casing symbol	Case φD×L (mm)	Casing symbol
5×11	E3	10×12.5	H3	12.5×20	I5	16×31.5	J7
6.3×11	F3	10×16	H4	12.5×25	I6	16×35.5	J8
8×11.5	G3	10×20	H5	16×25	J6	18×35.5	K8
						18×40	K9

Standard Ratings

Rated voltage (V)	6.3		10		16		25		35		50	
	Case φD×L (mm)	Rated ripple current (mArms)	Case φD×L (mm)	Rated ripple current (mArms)	Case φD×L (mm)	Rated ripple current (mArms)	Case φD×L (mm)	Rated ripple current (mArms)	Case φD×L (mm)	Rated ripple current (mArms)	Case φD×L (mm)	Rated ripple current (mArms)
1	—	—	—	—	—	—	—	—	—	—	5×11	20
2.2	—	—	—	—	—	—	—	—	—	—	5×11	26
3.3	—	—	—	—	—	—	—	—	—	—	5×11	32
4.7	—	—	—	—	—	—	5×11	34	5×11	34	6.3×11	43
10	—	—	—	—	5×11	543	6.3×11	57	6.3×11	57	8×11.5	75
22	—	—	5×11	56	6.3×11	74	8×11.5	99	8×11.5	99	10×12.5	131
33	—	—	6.3×11	79	6.3×11	90	8×11.5	121	10×12.5	144	10×16	176
47	—	—	6.3×11	94	8×11.5	127	10×12.5	172	10×12.5	172	10×16	210
100	—	—	8×11.5	160	10×12.5	220	10×16	270	10×20	300	12.5×20	380
220	10×12.5	260	10×16	350	10×20	390	12.5×20	510	12.5×25	550	16×25	720
330	10×16	350	10×20	460	12.5×20	550	12.5×25	680	16×25	790	16×31.5	970
470	10×20	460	12.5×20	570	12.5×25	650	16×25	940	16×25	940	16×35.5	1210
1000	12.5×25	840	12.5×25	910	16×25	1210	16×35.5	1580	18×35.5	1690	—	—
2200	16×25	1440	16×31.5	1710	18×35.5	2200	—	—	—	—	—	—

(Note) Rated ripple current : 85°C, 120Hz

NOTE

Design, Specifications are subject to change without notice.
Ask factory for technical specifications before purchase and/or use.

Large Capacitance Aluminum Electrolytic Capacitors

PCB Snap-In Miniaturized Capacitors

GREEN CAP

- 20mm-tall products for every diameter of $\phi 22$ to $\phi 35$ are now offered in series.
- As many as 4 case sizes available for the same rating.



Marking color : White print on a black sleeve



Specifications

Item	Performance																													
Category temperature range (°C)	-40 to +85 (450V is at -25 to +85)																													
Tolerance at rated capacitance (%)	±20 (20°C, 120Hz)																													
Leakage current (μA)	Less than 0.01CV or 1.5mA whichever is smaller (after 5 minutes) C : Rated capacitance (μF) ; V : Rated voltage (V) (20°C)																													
Tangent of loss angle	<table border="1"> <tr> <th>Rated voltage (V)</th> <td>10</td> <td>16</td> <td>25</td> <td>35</td> <td>50</td> <td>63 to 100</td> </tr> <tr> <th>tanδ (max.)</th> <td>0.80</td> <td>0.60</td> <td>0.50</td> <td>0.40</td> <td>0.30</td> <td>0.20</td> </tr> </table>	Rated voltage (V)	10	16	25	35	50	63 to 100	tanδ (max.)	0.80	0.60	0.50	0.40	0.30	0.20															
	Rated voltage (V)	10	16	25	35	50	63 to 100																							
tanδ (max.)	0.80	0.60	0.50	0.40	0.30	0.20																								
	<table border="1"> <tr> <th rowspan="2">tanδ (max.)</th> <th rowspan="2">φD</th> <th colspan="2">Rated voltage (V)</th> </tr> <tr> <th>160 to 250</th> <th>315 to 450</th> </tr> <tr> <td></td> <td>22 to 30</td> <td>0.10</td> <td>0.15</td> </tr> <tr> <td></td> <td>35</td> <td>0.15</td> <td>0.15</td> </tr> </table> <p>(20°C, 120Hz)</p>	tanδ (max.)	φD	Rated voltage (V)		160 to 250	315 to 450		22 to 30	0.10	0.15		35	0.15	0.15															
tanδ (max.)	φD			Rated voltage (V)																										
		160 to 250	315 to 450																											
	22 to 30	0.10	0.15																											
	35	0.15	0.15																											
Characteristics at high and low temperature	<table border="1"> <tr> <th rowspan="2">Impedance ratio (max.)</th> <th colspan="7">Rated voltage (V)</th> </tr> <tr> <th>10</th> <th>16 to 35</th> <th>50 to 100</th> <th>160 to 200</th> <th>250 to 400</th> <th>450</th> </tr> <tr> <td></td> <td>Z-25°C/Z+20°C</td> <td>4</td> <td>3</td> <td>3</td> <td>4</td> <td>4</td> </tr> <tr> <td></td> <td>Z-40°C/Z+20°C</td> <td>18</td> <td>15</td> <td>10</td> <td>6</td> <td>8</td> <td>—</td> </tr> </table> <p>(120Hz)</p>	Impedance ratio (max.)	Rated voltage (V)							10	16 to 35	50 to 100	160 to 200	250 to 400	450		Z-25°C/Z+20°C	4	3	3	4	4		Z-40°C/Z+20°C	18	15	10	6	8	—
	Impedance ratio (max.)		Rated voltage (V)																											
10		16 to 35	50 to 100	160 to 200	250 to 400	450																								
	Z-25°C/Z+20°C	4	3	3	4	4																								
	Z-40°C/Z+20°C	18	15	10	6	8	—																							
Endurance (85°C) (Applied ripple current)	Test time	2000 hours																												
	Leakage current	The initial specified value or less																												
	Percentage of capacitance change	Within ±20% of initial value																												
	Tangent of the loss angle	200% or less of the initial specified value																												
Shelf life (85°C)	Test time	1000 hours																												
	Leakage current	The initial specified value or less																												
	Percentage of capacitance change	Within ±15% of initial value																												
	Tangent of the loss angle	150% or less of the initial specified value																												
Voltage application treatment																														
Applicable standards	JIS C5101-1, -4 1998 (IEC 60384-1 1992, -4 1985)																													

Outline Drawing

Unit : mm

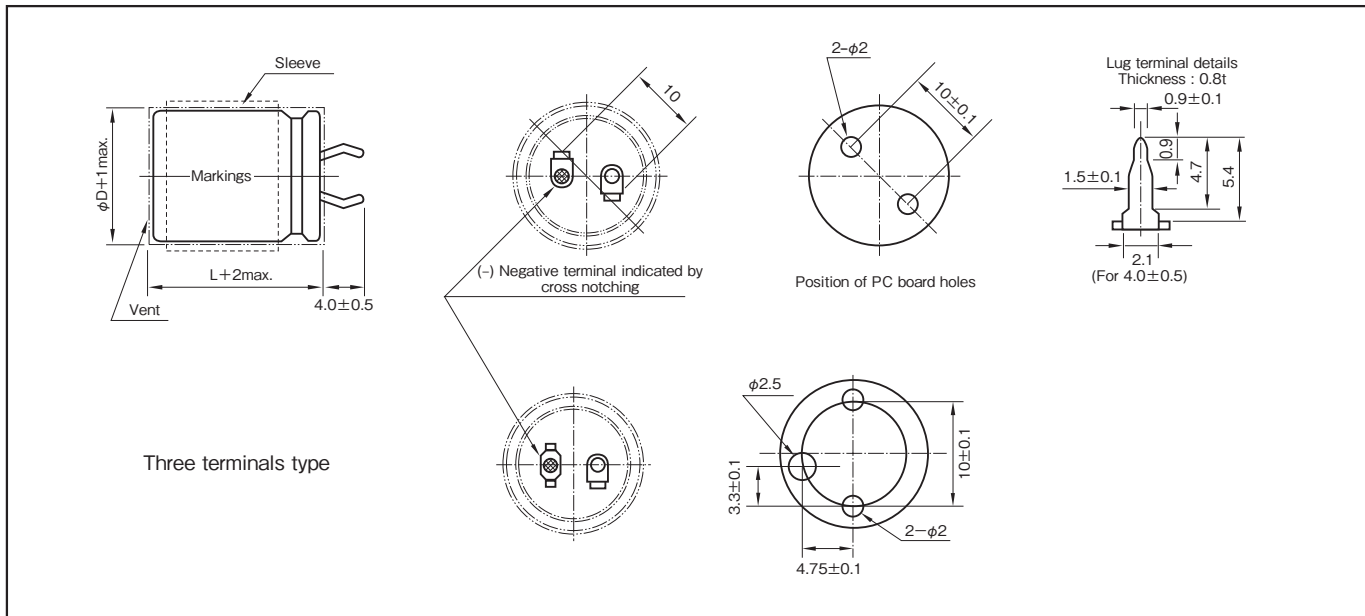

Part numbering system (example : 400V220μF)						
LA5	—	400	V	221	M	S43 # B
Series code	Rated voltage symbol	Rated capacitance symbol	Capacitance tolerance symbol	Casing symbol		Optional symbol

Coefficient of Frequency for Rated Ripple Current

Rated voltage (V)	Frequency (Hz)				
	50	120	1k	10k	20k
100 or less	0.95	1	1.10	1.15	1.15
160 to 250	0.87	1	1.11	1.18	1.20
315 or more	0.80	1	1.14	1.19	1.20

In the case of three terminals type, a series name is "LT5".

NOTE

Design, Specifications are subject to change without notice. Ask factory for technical specifications before purchase and/or use.

Standard Ratings

Case φDxL (mm)	Casing symbol	10			16			25			35			50			63			80			100		
		Rated capacitance (μF)	ESR (Ω)	Rated ripple current (Arms)	Rated capacitance (μF)	ESR (Ω)	Rated ripple current (Arms)	Rated capacitance (μF)	ESR (Ω)	Rated ripple current (Arms)	Rated capacitance (μF)	ESR (Ω)	Rated ripple current (Arms)	Rated capacitance (μF)	ESR (Ω)	Rated ripple current (Arms)	Rated capacitance (μF)	ESR (Ω)	Rated ripple current (Arms)	Rated capacitance (μF)	ESR (Ω)	Rated ripple current (Arms)	Rated capacitance (μF)	ESR (Ω)	Rated ripple current (Arms)
22x20	S21	8200	0.101	2.0	5600	0.118	1.9	3900	0.128	1.8	2700	0.154	1.6	1800	0.184	1.6	1500	0.166	1.7	1000	0.249	1.5	560	0.444	1.3
22x25	S22	12000	0.069	2.5	8200	0.081	2.4	5600	0.089	2.3	3900	0.106	2.1	2700	0.123	2.1	2200	0.113	2.2	1500	0.166	1.9	820	0.303	1.7
22x30	S23	15000	0.055	3.0	12000	0.055	3.0	8200	0.061	2.8	4700	0.088	2.4	3900	0.085	2.6	2700	0.092	2.5	1800	0.138	2.2	1200	0.207	2.1
22x35	S24	22000	0.038	3.7	15000	0.044	3.4	10000	0.050	3.2	6800	0.061	2.9	4700	0.071	3.1	3300	0.075	2.9	2200	0.113	2.5	1500	0.166	2.5
22x40	S25	—	—	—	18000	0.037	3.9	12000	0.041	3.7	8200	0.051	3.3	5600	0.059	3.4	3900	0.064	3.3	2700	0.092	2.8	1800	0.138	2.8
22x45	S26	27000	0.031	4.3	—	—	—	—	—	—	—	—	—	—	—	—	4700	0.053	3.7	3300	0.075	3.2	2200	0.113	3.2
22x50	S27	33000	0.025	4.9	22000	0.030	4.5	15000	0.033	4.3	10000	0.041	3.9	6800	0.049	3.9	5600	0.044	4.1	3900	0.064	3.6	—	—	—
25x20	S31	12000	0.069	2.5	8200	0.081	2.4	5600	0.089	2.2	3900	0.106	2.0	2700	0.123	2.1	1800	0.138	2.0	1200	0.207	1.7	820	0.303	1.7
25x25	S32	18000	0.046	3.2	12000	0.055	2.9	8200	0.061	2.8	5600	0.074	2.6	3900	0.085	2.6	2700	0.092	2.0	1800	0.138	2.2	1200	0.207	2.1
25x30	S33	22000	0.038	3.7	15000	0.044	3.4	10000	0.050	3.2	6800	0.061	2.9	4700	0.071	3.0	3900	0.064	3.2	2200	0.113	2.5	1500	0.166	2.5
25x35	S34	27000	0.031	4.2	18000	0.037	3.9	12000	0.041	3.7	8200	0.051	3.3	5600	0.059	3.4	4700	0.053	3.6	3300	0.075	3.1	1800	0.138	2.8
25x40	S35	33000	0.025	4.8	22000	0.030	4.4	15000	0.033	4.2	10000	0.041	3.8	6800	0.049	3.8	5600	0.044	4.0	3900	0.064	3.5	2200	0.113	3.2
25x45	S36	39000	0.021	5.4	27000	0.025	5.0	18000	0.028	4.7	12000	0.035	4.3	8200	0.040	4.3	6800	0.037	4.6	—	—	—	2700	0.092	2.9
25x50	S37	47000	0.018	6.0	—	—	—	22000	0.023	5.4	15000	0.028	4.9	10000	0.033	4.9	—	—	—	4700	0.053	4.0	3300	0.075	4.1
30x20	S41	18000	0.046	3.3	12000	0.055	3.0	8200	0.061	2.9	5600	0.074	2.6	3900	0.085	2.7	2700	0.092	2.6	1800	0.138	2.2	1200	0.207	2.2
30x25	S42	27000	0.031	4.2	18000	0.037	3.9	12000	0.041	3.7	8200	0.051	3.3	5600	0.059	3.4	4700	0.064	3.3	2700	0.092	2.9	1800	0.138	2.8
30x30	S43	33000	0.025	4.9	22000	0.030	4.4	15000	0.033	4.3	10000	0.041	3.8	6800	0.049	3.9	5600	0.044	4.1	3900	0.064	3.6	2200	0.113	3.2
30x35	S44	39000	0.021	5.5	27000	0.025	5.1	18000	0.028	4.8	12000	0.035	4.3	8200	0.040	4.4	6800	0.037	4.6	4700	0.053	4.0	2700	0.092	3.7
30x40	S45	47000	0.018	6.1	33000	0.020	5.8	22000	0.023	5.5	15000	0.028	5.0	10000	0.033	5.0	8200	0.030	5.2	5600	0.044	4.5	3300	0.075	4.2
30x45	S46	56000	0.015	6.9	39000	0.017	6.4	27000	0.018	6.2	18000	0.023	5.6	12000	0.028	5.6	10000	0.025	5.9	6800	0.037	5.1	3900	0.064	4.7
30x50	S47	68000	0.012	7.7	47000	0.014	7.2	33000	0.015	7.0	22000	0.019	6.3	15000	0.022	6.4	—	—	—	—	—	—	4700	0.053	5.2
35x20	S51	22000	0.038	3.9	15000	0.044	3.7	10000	0.050	3.5	6800	0.061	3.1	4700	0.071	3.2	3900	0.064	3.4	2700	0.092	3.0	1500	0.166	2.7
35x25	S52	33000	0.025	5.0	22000	0.030	4.6	15000	0.033	4.4	10000	0.041	4.0	6800	0.049	4.0	5600	0.044	4.2	3900	0.064	3.7	2200	0.113	3.4
35x30	S53	47000	0.018	6.2	33000	0.020	5.8	22000	0.023	5.5	15000	0.028	5.0	10000	0.033	5.0	8200	0.037	4.8	4700	0.053	4.2	3300	0.075	4.3
35x35	S54	56000	0.015	7.0	39000	0.017	6.5	27000	0.018	6.2	18000	0.023	5.7	12000	0.028	5.7	10000	0.030	5.5	6800	0.044	4.7	3900	0.064	4.8
35x40	S55	68000	0.012	7.9	47000	0.014	7.4	33000	0.015	7.2	22000	0.019	6.4	15000	0.022	6.5	10000	0.025	6.2	6800	0.037	5.3	4700	0.053	5.4
35x45	S56	82000	0.010	8.9	56000	0.012	8.2	39000	0.013	8.0	—	—	—	18000	0.018	7.3	12000	0.021	6.9	8200	0.030	6.0	5600	0.044	6.0
35x50	S57	—	—	—	—	—	—	—	—	—	27000	0.015	7.4	—	—	—	15000	0.017	7.9	10000	0.025	6.8	—	—	—

Case φDxL (mm)	Casing symbol	160			180			200			250			315			350			400			450		
		Rated capacitance (μF)	ESR (Ω)	Rated ripple current (Arms)	Rated capacitance (μF)	ESR (Ω)	Rated ripple current (Arms)	Rated capacitance (μF)	ESR (Ω)	Rated ripple current (Arms)	Rated capacitance (μF)	ESR (Ω)	Rated ripple current (Arms)	Rated capacitance (μF)	ESR (Ω)	Rated ripple current (Arms)	Rated capacitance (μF)	ESR (Ω)	Rated ripple current (Arms)	Rated capacitance (μF)	ESR (Ω)	Rated ripple current (Arms)	Rated capacitance (μF)	ESR (Ω)	Rated ripple current (Arms)
22x20	S21	270	0.614	1.2	220	0.754	1.1	180	0.922	1.0	150	1.106	0.94	100	2.488	0.78	68	3.659	0.61	56	4.443	0.54	47	5.294	0.49
22x25	S22	390	0.425	1.5	330	0.503	1.4	270	0.614	1.3	220	0.754	1.2	150	1.659	1.0	100	2.488	0.78	82	3.034	0.69	68	3.659	0.62
22x30	S23	560	0.296	1.9	470	0.353	1.8	390	0.425	1.6	270	0.614	1.4	180	1.382	1.1	150	1.659	1.0	120	2.073	0.86	82	3.034	0.71
22x35	S24	680	0.244	2.2	560	0.296	2.0	470	0.353	1.9	330	0.503	1.6	220	1.131	1.3	180	1.382	1.1	150	1.659	1.0	100	2.488	0.82
22x40	S25	820	0.202	2.5	680	0.244	2.3	560	0.296	2.1	390	0.425	1.8	270	0.922	1.5	220	1.131	1.3	180	1.382	1.1	120	2.073	0.92
22x45	S26	—	—	—	820	0.202	2.6	680	0.244	2.4	470	0.353	2.0	330	0.754	1.7	—	—	—	220	1.131	1.3	150	1.659	1.1
22x50	S27	1000	0.166	2.9	—	—	—	820	0.202	2.6	560	0.296	2.2	—	—	—	270	0.922	1.5	—	—	—	180	1.382	1.2
25x20	S31	390	0.425	1.5	330	0.503	1.4	270	0.614	1.3	180	0.922	1.1	120	2.073	0.88	100	2.488	0.77	82	3.034	0.69	56	4.443	0.57
25x25	S32	560	0.296	1.9	470	0.353	1.8	390	0.425	1.6	270	0.614	1.4	180	1.382	1.1	150	1.659	0.99	120	2.073	0.87	82	3.034	0.72
25x30	S33	680	0.244	2.2	560	0.296	2.0	470	0.353	1.9	390	0.425	1.7	270	0.922	1.4	180	1.382	1.1	150	1.659	1.0	120	2.073	0.91
25x35	S34	820	0.202	2.5	680	0.244	2.3	560	0.296	2.4	470	0.353	2.0	330	0.754	1.7	220	1.131	1.3	180	1.382	1.1	150	1.659	1.0
25x40	S35	1000	0.166	2.8	820	0.202	2.6	680	0.244	2.6	560	0.296	2.2	390	0.638	1.8	270	0.922	1.5	220	1.131	1.3	180	1.382	1.2
25x45	S36	1200	0.138	3.2	1000	0.166	2.9	—	—	—	680	0.244	2.5	—	—	—	330	0.754	1.7	270	0.922	1.5	—	—	—
25x50	S37	1500	0.111	3.6	1200	0.138	3.3	1000	0.166	3.0	—	—	—	470	0.529	2.1	390	0.638	1.9	330	0.754	1.7	220	1.131	1.4
30x20	S41	560	0.296	2.0	470	0.353	1.8	390	0.425	1.7	270	0.614	1.4	180	1.382	1.2	150	1.659	1.0	120	2.073	0.93	82	3.034	0.77
30x25	S42	820	0.202	2.5	680	0.244	2.3	560	0.296	2.1	390	0.425	1.8	270	0.922	1.5	220	1.131	1.3	180	1.382	1.2	120	2.073	0.97
30x30	S43	1000	0.166	2.9	820	0.202	2.6	680	0.244	2.7	560	0.296	2.3	390	0.638	1.9	270	0.922	1.5	220	1.131	1.4	180	1.382	1.2
30x35	S44	1200	0.138	3.3	1200	0.138	3.3	1000	0.166	3.0	680	0.244	2.6	470	0.529	2.1	330	0.754	1.7	270	0.922	1.6	220	1.131	1.4
30x40	S45	1500	0.111	3.7	—	—	—	1200	0.138	3.4	820	0.202	2.9	560	0.444	2.4	390	0.638	1.9	330	0.754	1.8	270	0.922	1.6
30x45	S46	1800	0.092	4.2	1500	0.111	3.9	—	—	—	1000	0.166	3.3	680	0.366	2.7	470	0.529	2.1	390	0.638	2.0			

Ultra Miniaturized, High-Reliability, High-Ripple Capacitors

GREEN
CAP

105°C
2000hours

- Best suited as input filters for various power supplies.
- Guarantees 2000 hours at 105°C.



Marking color : White print on a black sleeve

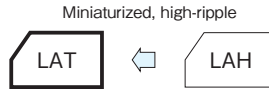

Specifications

Item	Performance	
Category temperature range (°C)	-25 to +105	
Tolerance at rated capacitance (%)	±20 (20°C, 120Hz)	
Leakage current (μA)	Less than 0.02CV or 3mA whichever is smaller (after 5 minutes) C : Rated capacitance (μF) ; V : Rated voltage (V) (20°C)	
Tangent of loss angle (tanδ)	Rated voltage (V)	160 to 250
	tanδ (max.)	0.15
Characteristics at high and low temperature	Percentage of capacitance change (%)	Within ±30% of the value at 20°C
	Impedance ratio (max.)	4 (120Hz)
Endurance (105°C) (Applied ripple current)	Test time	2000 hours
	Leakage current	The initial specified value or less
	Percentage of capacitance change	Within ±20% of initial value
	Tangent of the loss angle	200% or less of the initial specified value
Shelf life (105°C)	Test time	1000 hours
	Leakage current	The initial specified value or less
	Percentage of capacitance change	Within ±15% of initial value
	Tangent of the loss angle	150% or less of the initial specified value
Applicable standards	Voltage application treatment JIS C5101-1, -4 1998 (IEC 60384-1 1992, -4 1985)	

Outline Drawing

Unit : mm

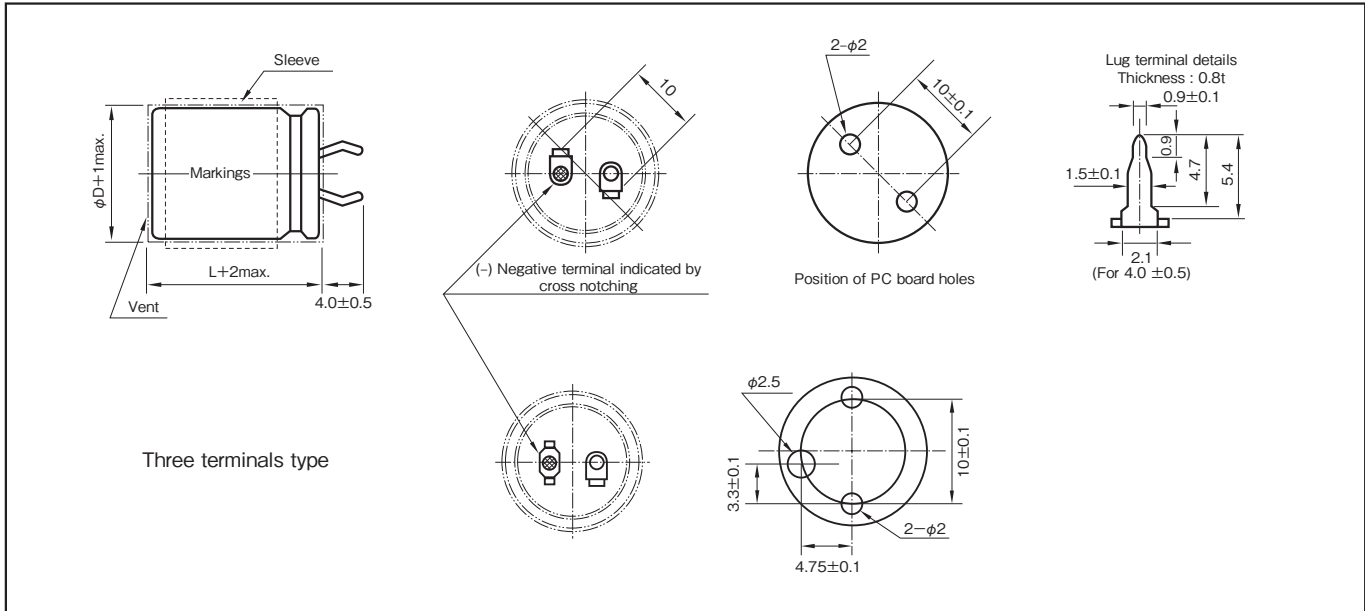

Part numbering system (example : 200V470μF)

LAT	—	200 V	471	M	S24 #	B
Series code		Rated voltage symbol	Rated capacitance symbol	Capacitance tolerance symbol	Casing symbol	Optional symbol

Coefficient of Frequency for Rated Ripple Current

Rated voltage (V)	Frequency (Hz)				
	50	120	1k	10k	30k
160 to 250	0.87	1	1.11	1.18	1.20
315 or more	0.80	1	1.14	1.19	1.20

In the case of three terminals type, a series name is "LTT".

- The electric characteristics are described on page 174.

NOTE

Design, Specifications are subject to change without notice.
Ask factory for technical specifications before purchase and/or use.

Standard Ratings

Rated voltage(V)			160		180		200		250		315		350	
Case φD×L(mm)	Casing symbol	Item	Rated capacitance	Rated ripple current	Rated capacitance	Rated ripple current	Rated capacitance	Rated ripple current	Rated capacitance	Rated ripple current	Rated capacitance	Rated ripple current	Rated capacitance	Rated ripple current
			(μF)	(Arms)	(μF)	(Arms)	(μF)	(Arms)	(μF)	(Arms)	(μF)	(Arms)	(μF)	(Arms)
22×20	S21		220	0.70	180	0.63	150	0.58	120	0.52	68	0.39	56	0.35
22×25	S22		390	1.30	330	1.20	270	1.10	220	1.00	120	0.75	100	0.51
22×30	S23		470	1.47	390	1.30	390	1.31	270	1.14	150	0.82	120	0.61
22×35	S24		560	1.58	470	1.50	470	1.50	330	1.26	180	0.91	150	0.73
22×40	S25		680	1.71	560	1.62	560	1.56	390	1.49	220	1.02	180	0.84
22×45	S26		820	2.00	680	1.70	680	1.74	470	1.57	270	1.16	220	0.98
22×50	S27		1000	2.20	820	2.00	820	1.99	560	1.67	330	1.20	270	1.09
25×20	S31		270	0.84	220	0.76	180	0.68	150	0.62	100	0.51	82	0.46
25×25	S32		470	1.55	390	1.35	390	1.35	270	1.18	180	0.90	150	0.68
25×30	S33		680	1.70	560	1.53	560	1.53	330	1.30	220	1.00	180	0.80
25×35	S34		820	2.00	680	1.74	680	1.74	470	1.57	270	1.10	220	0.99
25×40	S35		1000	2.20	820	2.00	820	1.95	560	1.79	330	1.20	270	1.09
25×45	S36		1200	2.45	1000	2.23	820	2.04	680	1.81	390	1.30	330	1.20
25×50	S37		1500	2.86	1200	2.51	1000	2.30	680	1.84	470	1.40	390	1.28
30×20	S41		390	1.13	330	1.04	330	1.04	220	0.92	150	0.70	120	0.69
30×25	S42		680	1.82	560	1.67	560	1.67	390	1.31	270	1.10	220	0.99
30×30	S43		1000	2.20	820	2.00	820	2.00	560	1.79	330	1.20	270	1.09
30×35	S44		1200	2.44	1000	2.24	1000	2.24	680	2.00	390	1.30	330	1.20
30×40	S45		1500	2.82	1200	2.52	1200	2.52	820	2.16	470	1.40	390	1.28
30×45	S46		1800	3.31	1500	2.89	1500	2.91	1000	2.37	560	1.50	470	1.37
30×50	S47		2200	3.81	1800	3.30	1500	3.03	1000	2.47	680	1.70	560	1.54
35×20	S51		560	1.49	470	1.37	470	1.37	330	1.14	180	0.83	150	0.76
35×25	S52		1000	2.20	820	2.00	820	2.00	560	1.68	330	1.20	270	1.09
35×30	S53		1500	2.50	1200	2.50	1000	2.30	680	1.75	470	1.40	390	1.28
35×35	S54		1800	2.92	1500	2.89	1200	2.65	820	2.00	560	1.50	470	1.37
35×40	S55		2200	3.34	1800	3.05	1500	3.08	1000	2.30	680	1.70	560	1.54
35×45	S56		2200	3.48	2200	3.46	1800	3.47	1200	2.43	820	2.00	680	1.82
35×50	S57		2700	3.97	2200	3.60	2200	3.78	1500	2.96	—	—	820	2.08

Rated voltage(V)			400		450		500	
Case φD×L(mm)	Casing symbol	Item	Rated capacitance	Rated ripple current	Rated capacitance	Rated ripple current	Rated capacitance	Rated ripple current
			(μF)	(Arms)	(μF)	(Arms)	(μF)	(Arms)
22×20	S21		56	0.39	56	0.35	22	0.24
			68	0.43	—	—	27	0.28
22×25	S22		82	0.64	68	0.52	33	0.32
			100	0.56	82	0.47	39	0.37
22×30	S23		100	0.69	100	0.56	47	0.41
			120	0.73	—	—	56	0.47
22×35	S24		120	0.75	120	0.65	68	0.54
			150	0.73	150	0.73	—	—
22×40	S25		150	0.82	150	0.77	82	0.62
			180	0.84	180	0.84	—	—
22×45	S26		180	0.90	180	0.89	100	0.67
			220	0.99	220	0.98	—	—
22×50	S27		220	1.05	220	1.03	120	0.77
			270	1.16	—	—	—	—
25×20	S31		68	0.46	56	0.38	—	—
			82	0.51	—	—	—	—
25×25	S32		120	0.75	100	0.71	—	—
			150	0.68	120	0.61	—	—
25×30	S33		150	0.84	150	0.82	68	0.54
			180	0.80	150	0.82	—	—
25×35	S34		180	0.94	180	0.96	82	0.62
			220	1.04	—	—	—	—
25×40	S35		220	1.07	220	1.00	100	0.67
			270	1.11	—	—	120	0.74
25×45	S36		270	1.20	270	1.17	150	0.82
			330	1.29	—	—	—	—
25×50	S37		330	1.32	270	1.22	180	0.98
			390	1.43	330	1.35	—	—
30×20	S41		82	0.52	82	0.52	—	—
			100	0.57	100	0.57	—	—
30×25	S42		150	0.82	150	0.83	—	—
			180	0.90	180	0.72	—	—
30×30	S43		220	1.06	220	1.12	100	0.67
			270	1.09	220	0.86	—	—
30×35	S44		270	1.21	270	1.24	120	0.77
			330	1.34	—	—	—	—
30×40	S45		330	1.39	330	1.18	150	0.85
			390	1.51	330	1.18	—	—
30×45	S46		390	1.55	330	1.46	180	1.01
			470	1.65	390	1.35	—	—
30×50	S47		470	1.69	390	1.58	220	1.12
			560	1.84	470	1.55	270	1.25
35×20	S51		120	0.75	120	0.72	—	—
			150	0.84	150	0.67	—	—
35×25	S52		220	1.08	220	1.04	—	—
			270	1.20	—	—	—	—
35×30	S53		330	1.20	270	1.26	120	0.80
			390	1.30	330	1.15	—	—
35×35	S54		390	1.54	390	1.54	150	0.85
			470	1.69	—	—	—	—
35×40	S55		470	1.74	470	1.59	220	1.12
			560	1.82	—	—	270	1.25
35×45	S56		560	1.85	470	1.64	330	1.36
			680	1.95	560	1.79	—	—
35×50	S57		680	2.03	560	2.02	390	1.54
			820	2.33	680	2.03	—	—

(Note) Rated ripple current : 105°C , 120Hz

NOTE

Design, Specifications are subject to change without notice.
Ask factory for technical specifications before purchase and/or use.

Miniaturized, High-Reliability, High-Ripple Capacitors

GREEN CAP 105°C
2000hours

- High-reliability, high-ripple capacitors.
- Guarantees 2000 hours at 105°C.

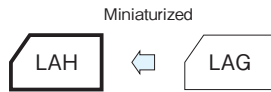

Marking color : White print on a black sleeve

Specifications

Item	Performance	
Category temperature range (°C)	-40 to +105 (-25 to +105 at 160V or more)	
Tolerance at rated capacitance (%)	± 20 (20°C, 120Hz)	
Leakage current (μA)	Less than 0.02CV or 3mA whichever is smaller (after 5 minutes) C : Rated capacitance (μF) ; V : Rated voltage (V) (20°C)	
Tangent of loss angle (tanδ)	Rated voltage (V)	16 25 35 50 63 to 100 160 to 250 400 to 450
	tanδ (max.)	0.50 0.40 0.35 0.30 0.20 0.15 0.20
Characteristics at high and low temperature	Rated voltage (V)	16 to 100 160 to 200 250 to 400
	Impedance ratio (max.)	Z-25°C/Z+20°C 4 4 4 Z-40°C/Z+20°C 15 — —
Endurance (105°C) (Applied ripple current)	Test time	2000 hours
	Leakage current	The initial specified value or less
	Percentage of capacitance change	Within ±20% of initial value
	Tangent of the loss angle	200% or less of the initial specified value
Shelf life (105°C)	Test time	1000 hours
	Leakage current	The initial specified value or less
	Percentage of capacitance change	Within ±15% of initial value
	Tangent of the loss angle	150% or less of the initial specified value
Applicable standards	JIS C5101-1, -4 1998 (IEC 60384-1 1992, -4 1985)	

Outline Drawing

Unit: mm

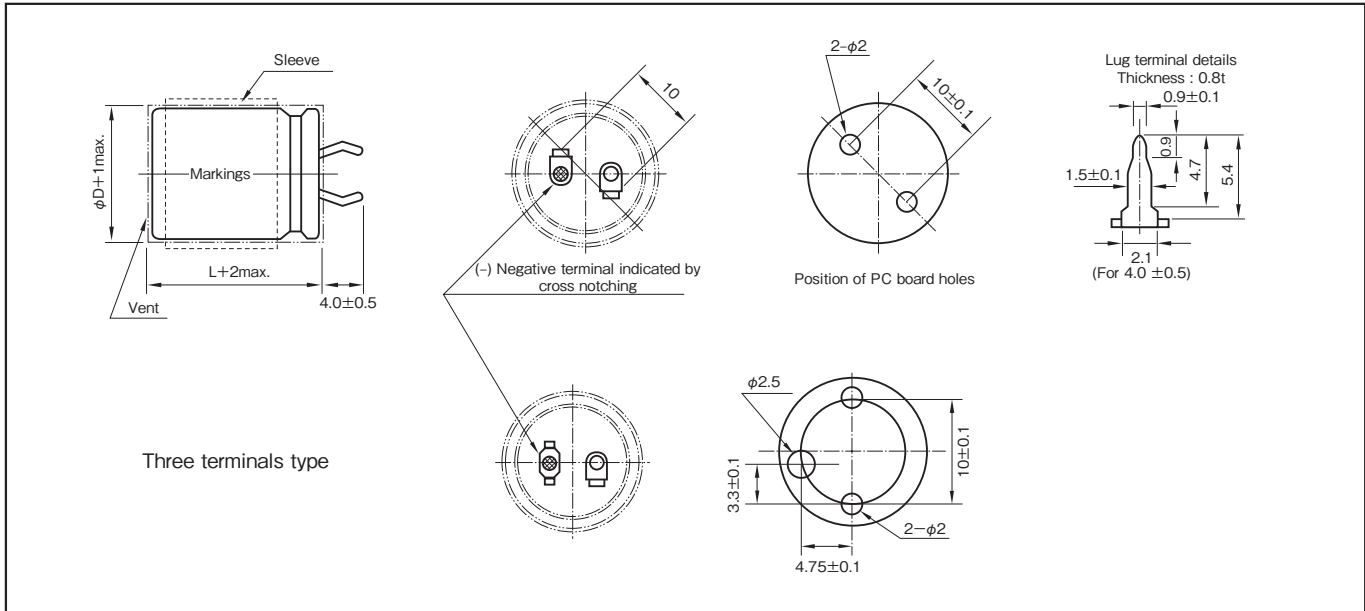

Part numbering system (example : 200V470μF)

LAH	—	200	V	471	M	S33	#	B
Series code		Rated voltage symbol		Rated capacitance symbol	Capacitance tolerance symbol	Casing symbol		Optional symbol

Coefficient of Frequency for Rated Ripple Current

Frequency (Hz)	50	120	1k	10k	30k
Rated voltage (V)					
100 or less	0.95	1	1.10	1.15	1.15
160 to 250	0.87	1	1.11	1.18	1.20
315 or more	0.80	1	1.14	1.19	1.20

In the case of three terminals type, a series name is "LTH".

NOTE

Design, Specifications are subject to change without notice.
Ask factory for technical specifications before purchase and/or use.

Standard Ratings

Case φD×L (mm)		Rated voltage(V)		16		25		35		50		63		80		100	
		Item Casing symbol	Rated capacitance (μF)	Rated ripple current (Arms)	Rated capacitance (μF)	Rated ripple current (Arms)	Rated capacitance (μF)	Rated ripple current (Arms)	Rated capacitance (μF)	Rated ripple current (Arms)	Rated capacitance (μF)	Rated ripple current (Arms)	Rated capacitance (μF)	Rated ripple current (Arms)	Rated capacitance (μF)	Rated ripple current (Arms)	
22×25	S22	6800	1.60	4700	1.55	3300	1.43	1800	1.31	1200	1.25	820	1.11	560	1.07		
22×30	S23	10000	1.99	6800	1.91	3900	1.65	2700	1.70	1800	1.52	1200	1.39	820	1.35		
22×35	S24	12000	2.28	8200	2.14	5600	2.02	3300	1.98	2200	1.73	1500	1.61	1000	1.54		
22×40	S25	15000	2.64	10000	2.40	6800	2.28	3900	2.25	2700	1.97	1800	1.83	1200	1.74		
22×45	S26	18000	2.98	12000	2.69	—	—	4700	2.56	—	—	2200	2.09	1500	1.99		
22×50	S27	—	—	—	—	8200	2.67	5600	2.89	3300	2.32	—	—	—	—		
25×25	S32	10000	1.99	6800	1.91	4700	1.78	2700	1.70	1800	1.52	1200	1.39	820	1.35		
25×30	S33	12000	2.30	8200	2.16	5600	2.04	3300	2.00	2200	1.75	1500	1.62	1000	1.56		
25×35	S34	15000	2.68	10000	2.44	6800	2.31	3900	2.28	2700	1.99	2200	2.01	1200	1.76		
25×40	S35	18000	3.04	12000	2.74	8200	2.60	5600	2.81	3300	2.27	—	—	1500	2.03		
25×45	S36	22000	3.40	15000	3.15	10000	2.92	—	—	3900	2.54	2700	2.43	1800	2.28		
25×50	S37	27000	3.81	18000	3.54	12000	3.26	6800	3.37	4700	2.88	3300	2.76	2200	2.57		
30×25	S42	12000	2.38	8200	2.25	5600	2.12	3900	2.22	2700	1.93	1800	1.81	1200	1.71		
30×30	S43	18000	3.00	12000	2.70	8200	2.56	4700	2.58	3300	2.24	2200	2.10	1500	2.00		
30×35	S44	22000	3.39	15000	3.13	10000	2.92	5600	2.95	3900	2.55	2700	2.43	1800	2.27		
30×40	S45	27000	3.83	18000	3.54	12000	3.28	6800	3.39	4700	2.90	3300	2.78	2200	2.59		
30×45	S46	33000	4.30	22000	4.24	15000	3.74	8200	3.71	5600	3.28	3900	3.12	2700	2.94		
30×50	S47	39000	4.74	—	—	—	—	10000	4.09	6800	3.73	4700	3.56	3300	3.32		
35×25	S52	18000	3.10	12000	2.80	8200	2.78	4700	2.67	3300	2.41	2200	2.17	1500	2.07		
35×30	S53	27000	3.74	15000	3.22	12000	3.20	6800	3.31	4700	2.83	3300	2.71	2200	2.52		
35×35	S54	33000	4.24	22000	3.96	15000	3.69	8200	3.66	5600	3.24	3900	3.07	2700	2.90		
35×40	S55	39000	4.72	—	—	18000	4.16	10000	4.07	6800	3.71	4700	3.50	3300	3.31		
35×45	S56	47000	5.27	27000	4.75	—	—	12000	4.50	8200	4.16	5600	3.87	3900	3.69		
35×50	S57	—	—	33000	5.39	22000	4.92	—	—	10000	4.69	6800	4.19	4700	4.14		

Case φD×L (mm)		Rated voltage(V)		160		180		200		250		400		450	
		Item Casing symbol	Rated capacitance (μF)	Rated ripple current (Arms)	Rated capacitance (μF)	Rated ripple current (Arms)	Rated capacitance (μF)	Rated ripple current (Arms)	Rated capacitance (μF)	Rated ripple current (Arms)	Rated capacitance (μF)	Rated ripple current (Arms)	Rated capacitance (μF)	Rated ripple current (Arms)	
22×25	S22	330	1.16	270	1.08	220	1.08	180	0.94	68	0.47	56	0.47		
22×30	S23	390	1.43	330	1.30	330	1.30	220	1.10	82	0.56	68	0.56		
22×35	S24	470	1.52	470	1.50	390	1.41	270	1.13	120	0.64	82	0.64		
22×40	S25	560	1.62	560	1.62	470	1.50	330	1.20	150	0.70	100	0.70		
22×45	S26	680	1.70	—	—	560	1.58	390	1.26	—	—	120	0.73		
22×50	S27	820	1.81	680	1.76	680	1.68	470	1.37	180	0.78	150	0.78		
25×25	S32	470	1.55	390	1.35	330	1.35	220	1.15	82	0.65	68	0.65		
25×30	S33	560	1.73	470	1.62	470	1.47	330	1.30	120	0.70	100	0.70		
25×35	S34	680	1.81	560	1.69	560	1.65	390	1.41	150	0.73	120	0.73		
25×40	S35	820	1.98	680	1.72	680	1.80	470	1.52	180	0.82	150	0.82		
25×45	S36	1000	2.04	820	1.78	—	—	560	1.59	220	0.87	180	0.87		
25×50	S37	1200	2.12	1000	1.91	820	1.87	680	1.66	270	0.94	220	0.94		
30×25	S42	680	1.82	560	1.67	470	1.56	330	1.30	120	0.78	100	0.78		
30×30	S43	820	1.98	680	1.74	680	1.82	470	1.36	180	0.83	150	0.83		
30×35	S44	1000	2.14	820	1.85	820	1.99	560	1.57	220	0.86	180	0.86		
30×40	S45	1200	2.22	1000	2.01	—	—	680	1.76	270	0.95	220	0.95		
30×45	S46	1500	2.46	1200	2.19	1000	2.17	820	1.83	330	1.11	270	1.11		
30×50	S47	—	—	1500	2.36	1200	2.22	1000	1.87	390	1.15	330	1.15		
35×25	S52	820	1.93	680	1.92	680	1.96	470	1.40	180	0.86	150	0.86		
35×30	S53	1200	2.40	1000	2.16	820	2.07	560	1.56	270	0.91	220	0.91		
35×35	S54	1500	2.53	1200	2.34	1000	2.22	820	1.82	330	1.13	270	1.13		
35×40	S55	—	—	1500	2.56	1200	2.42	1000	1.99	390	1.26	330	1.26		
35×45	S56	1800	2.98	1800	2.67	1500	2.59	1200	2.10	470	1.31	390	1.31		
35×50	S57	2200	3.10	—	—	1800	2.70	—	—	560	1.50	470	1.50		

(Note) Rated ripple current : 105°C , 120Hz

NOTE

Design, Specifications are subject to change without notice.
Ask factory for technical specifications before purchase and/or use.

High-Reliability, High-Ripple, Long Life Capacitors

GREEN CAP 105°C 3000hours

- High-reliability, high-ripple, long life capacitors.
- Guarantees 3000 hours at 105°C.

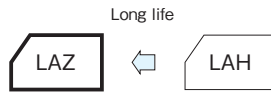

Marking color : White print on a black sleeve

Specifications

Item	Performance							
Category temperature range (°C)	-40 to +105 (-25 to +105 at 160V or more)							
Tolerance at rated capacitance (%)	±20 (20°C, 120Hz)							
Leakage current (μA)	Less than 0.02CV or 3mA whichever is smaller (after 5 minutes) C : Rated capacitance (μF) ; V : Rated voltage (V) (20°C)							
Tangent of loss angle (tanδ)	Rated voltage (V)	16	25	35	50	63 to 100	160 to 250	400 to 450
	tanδ (max.)	0.50	0.40	0.35	0.30	0.20	0.15	0.20
Characteristics at high and low temperature	Rated voltage (V)	16 to 100		160 to 200		250 to 400		(120Hz)
	Impedance ratio (max.)	Z-25°C/Z+20°C		4		4		
Endurance (105°C) (Applied ripple current)	Test time	3000 hours						
	Leakage current	The initial specified value or less						
	Percentage of capacitance change	Within ±20% of initial value						
	Tangent of the loss angle	200% or less of the initial specified value						
Shelf life (105°C)	Test time	1000 hours						
	Leakage current	The initial specified value or less						
	Percentage of capacitance change	Within ±15% of initial value						
	Tangent of the loss angle	150% or less of the initial specified value						
Applicable standards	Voltage application treatment JIS C5101-1, -4 1998 (IEC 60384-1 1992, -4 1985)							

Outline Drawing

Unit: mm

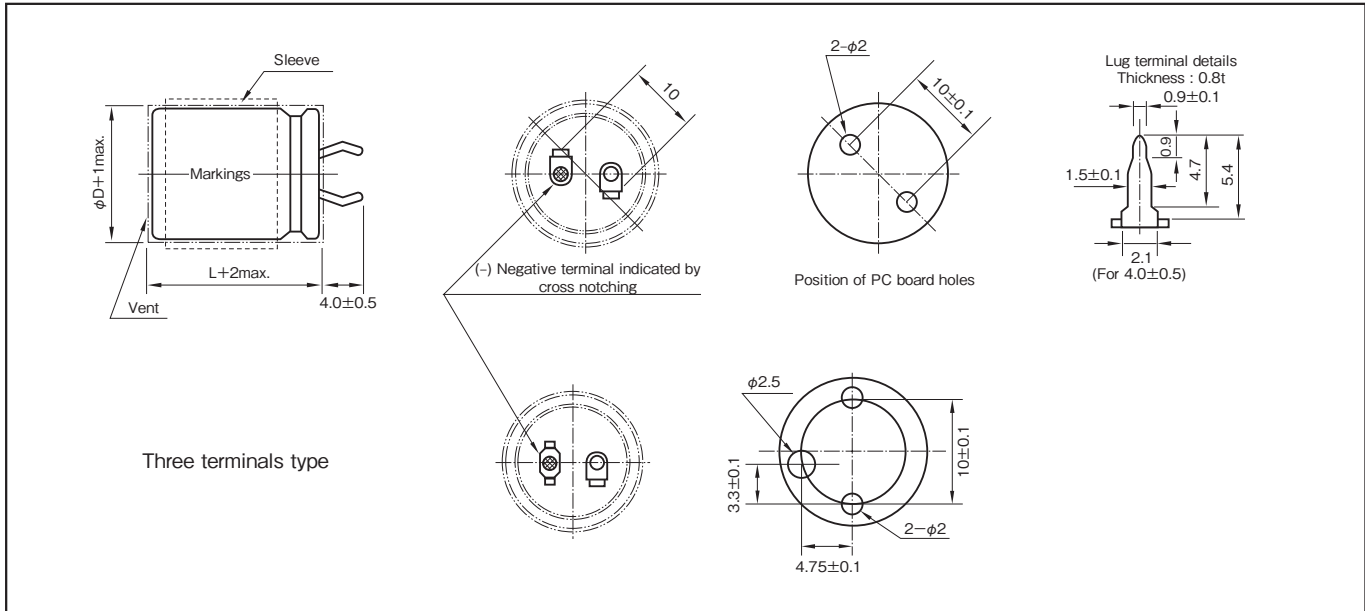

Part numbering system (example : 200V470μF)					
LAZ	—	200	V	471	M S33 # B
Series code	Rated voltage symbol	Rated capacitance symbol	Capacitance tolerance symbol	Casing symbol	Optional symbol

In the case of three terminals type, a series name is "LTZ".

Coefficient of Frequency for Rated Ripple Current

Rated voltage (V)	Frequency (Hz)				
	50	120	1k	10k	30k
100 or less	0.95	1	1.10	1.15	1.15
160 to 250	0.87	1	1.11	1.18	1.20
315 or more	0.80	1	1.14	1.19	1.20

- The electric characteristics are described on page 174.

NOTE

Design, Specifications are subject to change without notice. Ask factory for technical specifications before purchase and/or use.

Standard Ratings

Case φDxL (mm)	Item Casing symbol	16		25		35		50		63		80		100	
		Rated capacitance	Rated ripple current	Rated capacitance	Rated ripple current	Rated capacitance	Rated ripple current	Rated capacitance	Rated ripple current	Rated capacitance	Rated ripple current	Rated capacitance	Rated ripple current	Rated capacitance	Rated ripple current
		(μF)	(Arms)	(μF)	(Arms)	(μF)	(Arms)	(μF)	(Arms)	(μF)	(Arms)	(μF)	(Arms)	(μF)	(Arms)
22x25	S22	6800	1.60	4700	1.55	3300	1.43	1800	1.31	1200	1.25	820	1.11	560	1.07
22x30	S23	10000	1.99	6800	1.91	3900	1.65	2700	1.70	1800	1.52	1200	1.39	820	1.35
22x35	S24	12000	2.28	8200	2.14	5600	2.02	3300	1.98	2200	1.73	1500	1.61	1000	1.54
22x40	S25	15000	2.64	10000	2.40	6800	2.28	3900	2.25	2700	1.97	1800	1.83	1200	1.74
22x45	S26	18000	2.98	12000	2.69	—	—	4700	2.56	—	—	2200	2.09	1500	1.99
22x50	S27	—	—	—	—	8200	2.67	5600	2.89	3300	2.32	—	—	—	—
25x25	S32	10000	1.99	6800	1.91	4700	1.78	2700	1.70	1800	1.52	1200	1.39	820	1.35
25x30	S33	12000	2.30	8200	2.16	5600	2.04	3300	2.00	2200	1.75	1500	1.62	1000	1.56
25x35	S34	15000	2.68	10000	2.44	6800	2.31	3900	2.28	2700	1.99	2200	2.01	1200	1.76
25x40	S35	18000	3.04	12000	2.74	8200	2.60	5600	2.81	3300	2.27	—	—	1500	2.03
25x45	S36	22000	3.40	15000	3.15	10000	2.92	—	—	3900	2.54	2700	2.43	1800	2.28
25x50	S37	27000	3.81	18000	3.54	12000	3.26	6800	3.37	4700	2.88	3300	2.76	2200	2.57
30x25	S42	12000	2.38	8200	2.25	5600	2.12	3900	2.22	2700	1.93	1800	1.81	1200	1.71
30x30	S43	18000	3.00	12000	2.70	8200	2.56	4700	2.58	3300	2.24	2200	2.10	1500	2.00
30x35	S44	22000	3.39	15000	3.13	10000	2.92	5600	2.95	3900	2.55	2700	2.43	1800	2.27
30x40	S45	27000	3.83	18000	3.54	12000	3.28	6800	3.39	4700	2.90	3300	2.78	2200	2.59
30x45	S46	33000	4.30	22000	4.24	15000	3.74	8200	3.71	5600	3.28	3900	3.12	2700	2.94
30x50	S47	39000	4.74	—	—	—	—	10000	4.09	6800	3.73	4700	3.56	3300	3.32
35x25	S52	18000	3.10	12000	2.80	8200	2.78	4700	2.67	3300	2.41	2200	2.17	1500	2.07
35x30	S53	27000	3.74	15000	3.22	12000	3.20	6800	3.31	4700	2.83	3300	2.71	2200	2.52
35x35	S54	33000	4.24	22000	3.96	15000	3.69	8200	3.66	5600	3.24	3900	3.07	2700	2.90
35x40	S55	39000	4.72	—	—	18000	4.16	10000	4.07	6800	3.71	4700	3.50	3300	3.31
35x45	S56	47000	5.27	27000	4.75	—	—	12000	4.50	8200	4.16	5600	3.87	3900	3.69
35x50	S57	—	—	33000	5.39	22000	4.92	—	—	10000	4.69	6800	4.19	4700	4.14

Case φDxL (mm)	Item Casing symbol	160		180		200		250		400		450	
		Rated capacitance	Rated ripple current	Rated capacitance	Rated ripple current	Rated capacitance	Rated ripple current	Rated capacitance	Rated ripple current	Rated capacitance	Rated ripple current	Rated capacitance	Rated ripple current
		(μF)	(Arms)	(μF)	(Arms)	(μF)	(Arms)	(μF)	(Arms)	(μF)	(Arms)	(μF)	(Arms)
22x20	S21	180	0.70	180	0.70	150	0.65	120	0.60	47	0.37	—	—
22x25	S22	330	1.16	270	1.08	220	1.08	180	0.94	68	0.47	56	0.47
22x30	S23	390	1.43	330	1.30	330	1.30	220	1.10	82	0.56	68	0.56
		—	—	390	1.35	—	—	—	—	100	0.62	82	0.64
22x35	S24	470	1.52	470	1.50	390	1.41	270	1.13	120	0.75	82	0.65
		560	1.50	—	—	—	—	—	—	—	100	0.70	—
22x40	S25	560	1.62	560	1.62	470	1.50	330	1.30	150	0.83	100	0.70
		—	—	—	—	—	—	390	1.41	—	—	120	0.73
22x45	S26	680	1.70	680	1.75	560	1.58	390	1.49	180	0.98	120	0.77
		—	—	—	—	—	—	—	—	—	150	0.88	—
22x50	S27	820	1.91	680	1.80	680	1.78	470	1.50	220	1.10	150	0.90
		—	—	—	—	—	—	—	—	—	180	1.00	—
25x20	S31	220	0.81	220	0.85	220	0.85	150	0.74	68	0.46	—	—
		270	0.95	—	—	—	—	—	—	—	—	—	—
25x25	S32	390	1.30	390	1.35	330	1.35	220	1.15	82	0.65	68	0.56
		470	1.55	—	—	—	—	—	—	100	0.62	82	0.64
25x30	S33	560	1.73	470	1.62	470	1.47	330	1.30	120	0.70	100	0.70
		680	1.82	—	—	—	—	—	—	150	0.83	120	0.73
25x35	S34	680	1.85	560	1.69	560	1.65	390	1.41	150	0.85	120	0.77
		—	—	680	1.72	—	—	—	—	180	0.98	150	0.88
25x40	S35	820	1.98	680	1.75	680	1.80	470	1.52	180	1.01	150	0.90
		—	—	820	1.85	—	—	—	—	220	1.05	180	1.00
25x45	S36	1000	2.04	820	1.85	820	1.97	560	1.80	220	1.05	180	1.02
		1200	2.12	1000	1.91	—	—	—	—	270	1.22	220	1.12
25x50	S37	1200	2.20	1000	1.95	820	1.99	680	2.00	270	1.25	220	1.15
		—	—	—	—	1000	2.17	—	—	330	1.44	—	—
30x20	S41	390	1.25	330	1.15	270	1.05	220	0.95	100	0.60	—	—
30x25	S42	680	1.82	560	1.67	470	1.56	330	1.30	120	0.78	100	0.70
		—	—	—	—	—	—	390	1.41	150	0.83	120	0.73
30x30	S43	820	1.98	680	1.74	680	1.82	470	1.51	180	0.98	150	0.88
		—	—	820	1.85	—	—	560	1.70	220	1.03	180	0.95
30x35	S44	1000	2.14	820	1.90	820	1.99	560	1.80	220	1.10	180	0.99
		—	—	1000	2.01	—	—	680	1.90	270	1.22	220	1.12
30x40	S45	1200	2.22	1000	2.10	1000	2.17	680	2.00	270	1.23	220	1.16
		1500	2.46	1200	2.19	—	—	820	2.20	330	1.44	270	1.28
30x45	S46	1500	2.60	1200	2.19	1000	2.20	820	2.25	330	1.45	270	1.32
		—	—	1500	2.36	1200	2.32	—	—	390	1.60	—	—
30x50	S47	1800	2.98	1500	2.52	1200	2.39	1000	2.47	390	1.60	330	1.45
		—	—	—	—	1500	2.59	—	—	470	1.90	—	—
35x20	S51	560	1.55	470	1.40	470	1.56	330	1.16	150	0.80	—	—
35x25	S52	820	1.93	680	1.92	680	1.96	470	1.51	180	0.95	150	0.86
		—	—	820	1.95	—	—	560	1.65	220	1.03	—	—
35x30	S53	1200	2.40	1000	2.16	820	2.07	560	1.65	270	1.22	220	1.12
		—	—	—	—	1000	2.22	680	2.00	330	1.37	—	—
35x35	S54	1500	2.53	1200	2.34	1000	2.22	820	2.20	330	1.39	270	1.28
		—	—	1500	2.56	1200	2.42	—	—	390	1.60	—	—
35x40	S55	1800	2.98	1500	2.56	1200	2.42	1000	2.47	390	1.60	330	1.45
		—	—	1800	2.60	1500	2.59	—	—	470	1.85	390	1.45
35x45	S56	1800	3.00	1800	2.67	1500	2.61	1200	2.60	470	1.91	390	1.49
		2200	3.10	—	—	1800	2.70	—	—	560	2.12	—	—
35x50	S57	2200	3.20	2200	3.15	1800	2.85	1500	3.00	560	2.15	470	1.85
		2700	3.89	—	—	2200	3.30	—	—	—	—	—	—

(Note) Rated ripple current : 105°C , 120Hz

NOTE
Design, Specifications are subject to change without notice.
Ask factory for technical specifications before purchase and/or use.

Ultra Long Life, High-Reliability Capacitors

GREEN CAP 105°C 5000hours

- Ultra Long Life, high-reliability capacitors.
- Guarantees 5000 hours at 105°C.

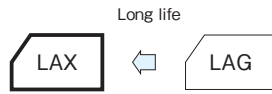

Marking color : White print on a black sleeve

Specifications

Item	Performance	
Category temperature range (°C)	-25 to +105	
Tolerance at rated capacitance (%)	±20 (20°C, 120Hz)	
Leakage current (µA)	Less than 0.02CV or 3mA whichever is smaller (after 5 minutes) C : Rated capacitance (µF) ; V : Rated voltage (V) (20°C)	
Tangent of loss angle (tanδ)	Rated voltage (V)	160 200 250 400
	tanδ (max.)	0.215 0.15 0.15 0.20
Characteristics at high and low temperature	Percentage of capacitance change (%)	-25°C Within ±30% of the value at 20°C
	Impedance ratio (max.)	Z-25°C/Z+20°C 4
Endurance (105°C) (Applied ripple current)	Test time	5000 hours
	Leakage current	The initial specified value or less
	Percentage of capacitance change	Within ±20% of initial value
	Tangent of the loss angle	200% or less of the initial specified value
Shelf life (105°C)	Test time	1000 hours
	Leakage current	The initial specified value or less
	Percentage of capacitance change	Within ±15% of initial value
	Tangent of the loss angle	150% or less of the initial specified value
Applicable standards	Voltage application treatment JIS C5101-1, -4 1998 (IEC 60384-1 1992, -4 1985)	

Standard Ratings

Case φDxL (mm)	Item	160		200		250		400	
		Rated capacitance (µF)	Rated ripple current (Arms)	Rated capacitance (µF)	Rated ripple current (Arms)	Rated capacitance (µF)	Rated ripple current (Arms)	Rated capacitance (µF)	Rated ripple current (Arms)
22x25	S22	270	0.91	180	0.75	150	0.68	56	0.34
22x30	S23	330	1.09	270	0.99	180	0.81	68	0.40
22x35	S24	390	1.27	330	1.16	220	0.95	82	0.47
22x40	S25	470	1.36	390	1.24	270	1.03	120	0.56
22x50	S27	680	1.52	470	1.37	390	1.16	150	0.63
25x25	S32	390	1.15	270	0.96	180	0.78	68	0.39
25x30	S33	470	1.36	330	1.14	270	1.03	100	0.51
25x35	S34	560	1.54	470	1.45	330	1.21	120	0.60
25x40	S35	680	1.68	560	1.55	390	1.29	150	0.66
25x50	S37	820	1.81	680	1.72	470	1.43	220	0.80
30x25	S42	560	1.45	330	1.11	270	1.01	100	0.50
30x30	S43	680	1.68	470	1.43	330	1.16	150	0.66
30x35	S44	820	1.82	560	1.66	470	1.33	180	0.77
30x40	S45	1000	1.90	680	1.79	560	1.48	220	0.83
30x50	S47	1200	2.09	1000	2.00	680	1.59	270	0.92
35x30	S53	820	1.93	680	1.76	470	1.33	180	0.74
35x35	S54	1000	2.15	820	2.05	560	1.55	220	0.87
35x40	S55	1500	2.52	1000	2.22	680	1.69	270	0.94
35x50	S57	1800	2.63	1200	2.43	1000	2.22	330	1.04

(Note) Rated ripple current : 105°C, 120Hz.

Outline Drawing

Unit : mm

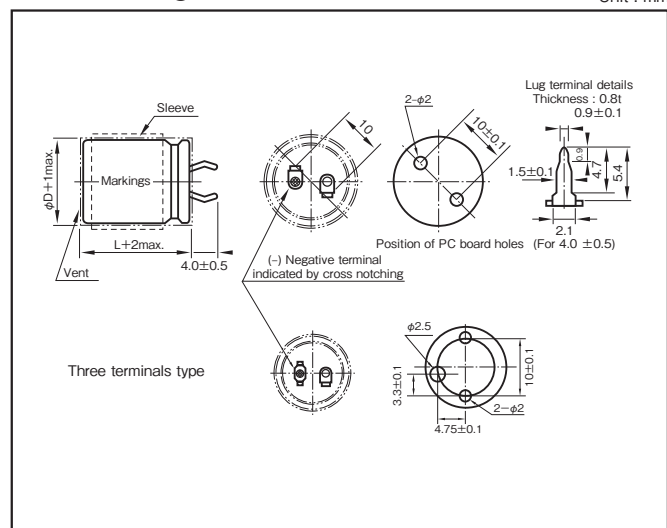

Coefficient of Frequency for Rated Ripple Current

Rated voltage (V) \ Frequency (Hz)	50	120	1k	10k	30k
160 to 250	0.87	1	1.11	1.18	1.20
400	0.80	1	1.14	1.19	1.20

Part numbering system (example : 200V470µF)

LAX	—	200	V	471	M	S34	#	B
Series code		Rated voltage symbol		Rated capacitance symbol	Capacitance tolerance symbol	Casing symbol		Optional symbol

In the case of three terminals type, a series name is "LTX".

- The electric characteristics are described on page 175.

MEMO

Large-capacitance, Long-Life, High-Reliability Capacitors

GREEN CAP

105°C
5000hours

- Large-capacitance, Long-Life, High-reliability capacitors.
- Guarantees 5000 hours at 105°C.

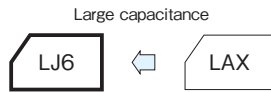

Marking color : White print on a black sleeve

Specifications

Item	Performance	
Category temperature range (°C)	-25~+105	
Tolerance at rated capacitance (%)	±20 (20°C, 120Hz)	
Leakage current (µA)	Less than 0.02CV or 5mA whichever is smaller (after 5 minutes) C : Rated capacitance (µF) ; V : Rated voltage (V) (20°C)	
Tangent of loss angle (tanδ)	Rated voltage (V)	200 to 500
	tanδ (max.)	0.15 (20°C, 120Hz)
Characteristics at high and low temperature	Percentage of capacitance change (%)	-25°C Within ±30% of the value at 20°C
	Impedance ratio (max.)	Z-25°C/Z+20°C 4 (120Hz)
Endurance (105°C) (Applied ripple current)	Test time	5000 hours
	Leakage current	The initial specified value or less
	Percentage of capacitance change	Within ±20% of initial value
	Tangent of the loss angle	200% or less of the initial specified value
Shelf life (105°C)	Test time	1000 hours
	Leakage current	The initial specified value or less
	Percentage of capacitance change	Within ±15% of initial value
	Tangent of the loss angle	150% or less of the initial specified value
Voltage application treatment		
Applicable standards	JIS C5101-1, -4 1998 (IEC 60384-1 1992, -4 1985)	

Outline Drawing

Unit : mm

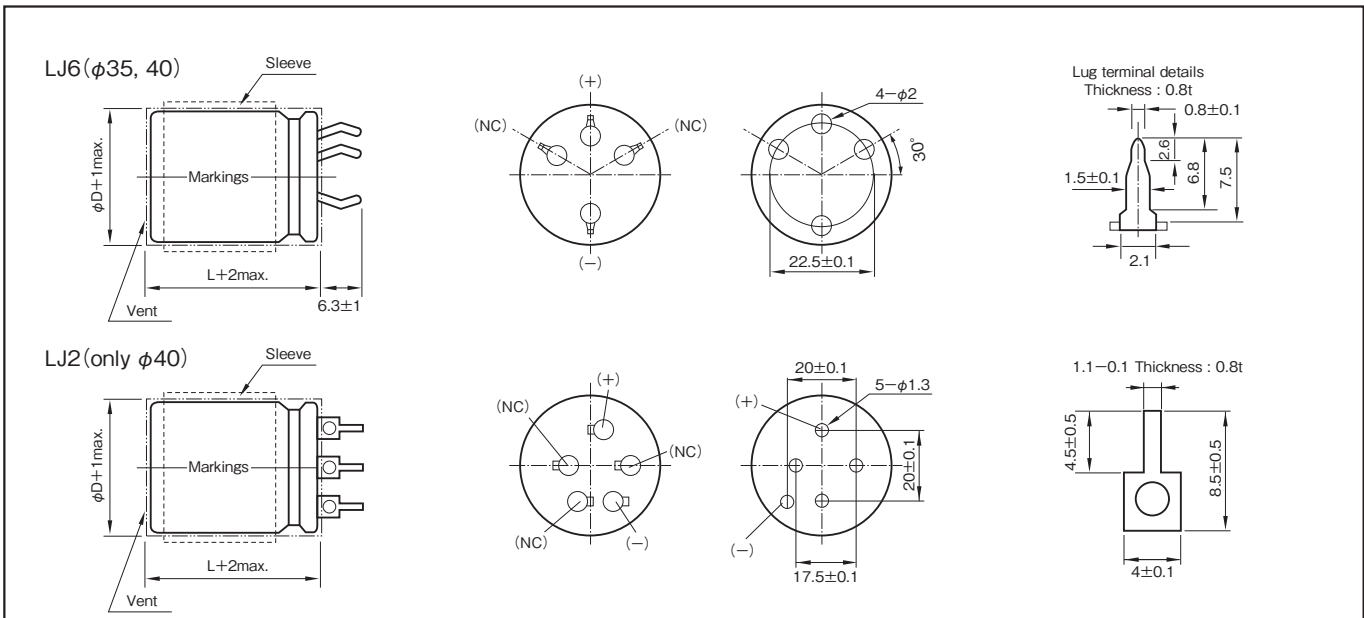

Part numbering system (example : 350V1500µF)

LJ6	—	350	V	152	M	S6D	#	B
Series code		Rated voltage symbol		Rated capacitance symbol	Capacitance tolerance symbol	Casing symbol		Optional symbol

Coefficient of Frequency for Rated Ripple Current

Frequency (Hz)	50	120	1k	10k	30k
Rated voltage (V)					
200 to 250	0.87	1	1.11	1.18	1.20
315 to 500	0.80	1	1.14	1.19	1.20

NOTE

Design, Specifications are subject to change without notice. Ask factory for technical specifications before purchase and/or use.

Standard Ratings

Rated voltage(V) Case φD×L(mm)		Item Casing symbol	200			250			315			350		
			Rated capacitance (μF)	ESR (Ω)	Rated ripple current (Arms)	Rated capacitance (μF)	ESR (Ω)	Rated ripple current (Arms)	Rated capacitance (μF)	ESR (Ω)	Rated ripple current (Arms)	Rated capacitance (μF)	ESR (Ω)	Rated ripple current (Arms)
35×60	S59	2200	0.090	4.05	1500	0.13	3.17	820	0.24	2.23	820	0.24	2.10	
35×70	S5B	2700	0.073	4.77	1800	0.11	3.69	1000	0.20	2.62	1000	0.20	2.46	
35×80	S5C	3300	0.060	5.56	2200	0.090	4.31	1200	0.17	3.03	1200	0.17	2.84	
35×90	S5D	—	—	—	—	—	—	1500	0.13	3.55	1500	0.13	3.34	
35×100	S5E	3900	0.051	6.64	2700	0.073	5.24	1800	0.11	4.07	1800	0.11	3.82	
40×60	S69	2200	0.090	4.40	1800	0.11	3.77	1000	0.20	2.68	1000	0.20	2.50	
40×70	S6B	2700	0.073	5.17	2200	0.090	4.43	1200	0.17	3.11	1200	0.17	2.90	
40×80	S6C	3300	0.060	6.02	—	—	—	1500	0.13	3.67	1500	0.13	3.40	
40×90	S6D	3900	0.051	7.00	2700	0.073	5.42	1800	0.11	4.21	1800	0.11	3.95	

Rated voltage(V) Case φD×L(mm)		Item Casing symbol	400			450			500		
			Rated capacitance (μF)	ESR (Ω)	Rated ripple current (Arms)	Rated capacitance (μF)	ESR (Ω)	Rated ripple current (Arms)	Rated capacitance (μF)	ESR (Ω)	Rated ripple current (Arms)
35×60	S59	820	0.24	2.49	560	0.36	2.16	390	0.51	1.65	
35×70	S5B	1000	0.20	2.93	680	0.29	2.53	470	0.42	1.92	
35×80	S5C	—	—	—	820	0.24	2.94	560	0.36	2.22	
35×90	S5D	1200	0.17	3.55	1000	0.20	3.41	680	0.29	2.57	
35×100	S5E	1500	0.13	4.15	1200	0.17	3.90	—	—	—	
40×60	S69	—	—	—	680	0.29	2.45	560	0.36	2.15	
40×70	S6B	1000	0.20	3.10	820	0.24	2.84	680	0.29	2.51	
40×80	S6C	—	—	—	1000	0.20	3.33	—	—	—	
40×90	S6D	1200	0.17	3.65	1200	0.17	3.65	820	0.24	3.05	
40×100	S6E	1500	0.13	4.30	—	—	—	1000	0.20	3.51	

(Note) ESR : 20°C , 120Hz ; Rated ripple current : 105°C , 120Hz

NOTE

Design, Specifications are subject to change without notice.
Ask factory for technical specifications before purchase and/or use.

LM, LPM LARGE CAPACITANCE ALUMINUM ELECTROLYTIC CAPACITORS **ELNA®**

For-Inverter, High-Ripple Capacitors

GREEN CAP 85°C 2000hours

- Withstands high-ripple current generated by the voltage doubler rectifier system.
- Guarantees 2000 hours at 85°C.



Marking color : White print on a black sleeve

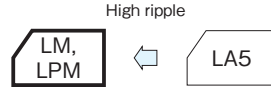

Specifications

Item	Performance	
Category temperature range (°C)	-25 to +85	
Tolerance at rated capacitance (%)	±20 (20°C, 120Hz)	
Leakage current (µA)	Less than 0.01CV or 5mA whichever is smaller (after 5 minutes) C : Rated capacitance (µF) ; V : Rated voltage (V) (20°C)	
Tangent of loss angle (tanδ)	Rated voltage (V)	250, 400
	tanδ (max.)	0.05 (20°C, 120Hz)
Characteristics at high and low temperature	Rated voltage (V)	250, 400
	Impedance ratio (max.) Z _{-25°C} /Z _{+20°C}	4 (120Hz)
Endurance (85°C) (Applied ripple current)	Test time	2000 hours
	Leakage current	The initial specified value or less
	Percentage of capacitance change	Within ±20% of initial value
	Tangent of the loss angle	200% or less of the initial specified value
Shelf life (85°C)	Test time	500 hours
	Leakage current	The initial specified value or less
	Percentage of capacitance change	Within ±15% of initial value
	Tangent of the loss angle	150% or less of the initial specified value
Applicable standards	Voltage application treatment JIS C5101-1, -4 1998 (IEC 60384-1 1992, -4 1985)	

Outline Drawing

Unit : mm

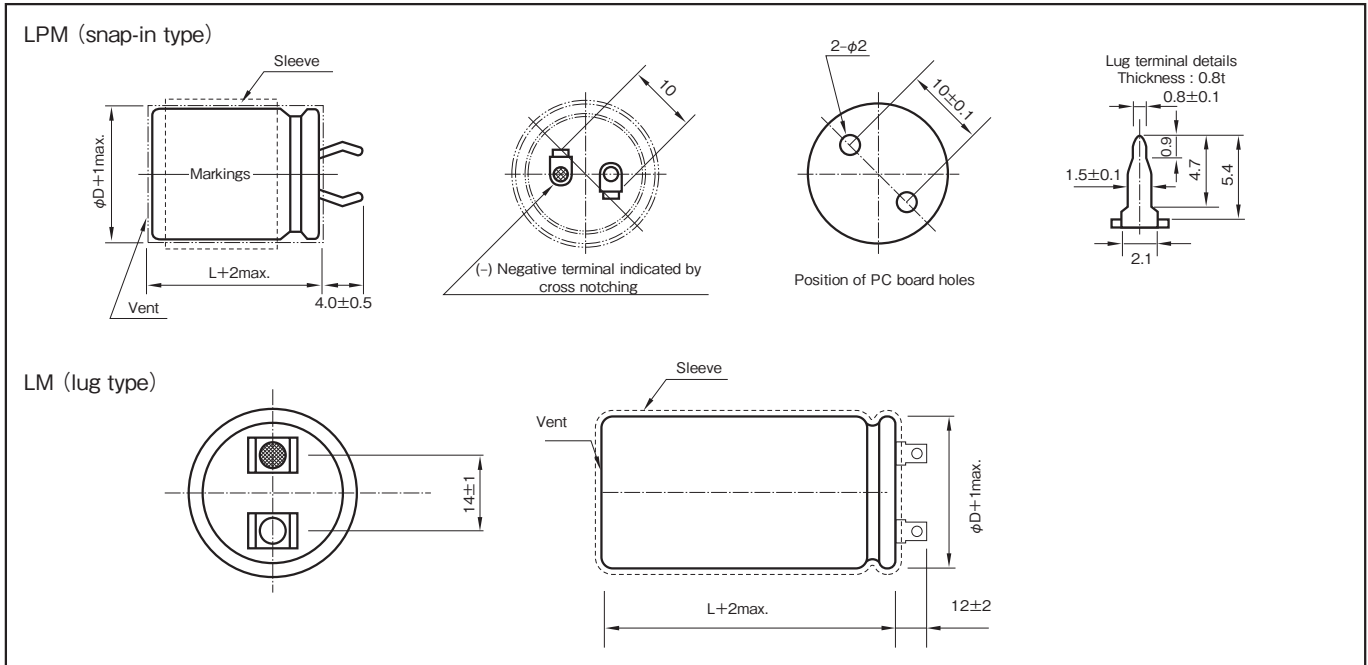

Part numbering system (example : 250V440µF)

LM	—	250 V	441	K	S6E #	B
Series code		Rated voltage symbol	Rated capacitance symbol	Capacitance tolerance symbol	Casing symbol	Optional symbol

Coefficient of Frequency for Rated Ripple Current

Rated voltage (V)	Frequency (Hz)				
	50	120	400	1k	10k
250, 400	0.80	1	1.32	1.46	1.61

NOTE

Design, Specifications are subject to change without notice. Ask factory for technical specifications before purchase and/or use.

LM series Standard Ratings

250V					
Rated capacitance (μ F)	Case (mm)		Casing symbol	ESR	Rated ripple current (Arms)
	ϕ D	L		(Ω max.)	
200	40	100	S6E	0.33	3.80
220	40	100	S6E	0.30	4.00
330	40	100	S6E	0.20	4.85
360	40	100	S6E	0.18	5.10
390	40	100	S6E	0.17	5.30
420	40	100	S6E	0.16	5.50
440	40	100	S6E	0.15	5.60

400V					
Rated capacitance (μ F)	Case (mm)		Casing symbol	ESR	Rated ripple current (Arms)
	ϕ D	L		(Ω max.)	
90	35	80	S5C	0.74	3.00
	40	80	S6C	0.74	3.00
100	35	90	S5D	0.66	3.20
	40	90	S6D	0.66	3.20
110	35	100	S5E	0.60	3.30
	40	100	S6E	0.60	3.30
150	35	100	S5E	0.44	3.90
	40	100	S6E	0.44	3.90
165	40	100	S6E	0.40	4.10
220	40	100	S6E	0.30	4.10

(Note) ESR : 20°C, 120Hz ; Rated ripple current : 85°C, 120Hz

LPM series Standard Ratings

250V					
Rated capacitance (μ F)	Case (mm)		Casing symbol	ESR	Rated ripple current (Arms)
	ϕ D	L		(Ω max.)	
100	35	40	S55	0.66	1.90
110	35	40	S55	0.60	2.00
165	35	45	S56	0.40	2.45
180	35	50	S57	0.37	2.58
195	35	50	S57	0.34	2.68
210	35	50	S57	0.32	2.78
220	35	50	S57	0.30	2.80

400V					
Rated capacitance (μ F)	Case (mm)		Casing symbol	ESR	Rated ripple current (Arms)
	ϕ D	L		(Ω max.)	
45	35	50	S57	1.47	1.50
55	35	40	S55	1.21	1.70
75	35	50	S57	0.88	1.98
82	35	50	S57	0.81	2.00

(Note) ESR : 20°C, 120Hz ; Rated ripple current : 85°C, 120Hz

Screw Terminal, Long Life, High Temperature capacitors

GREEN CAP 105°C 2000hours

- Screw Terminal, Long Life, High Temperature capacitors.
- Guarantees 5000 hours at 105°C.



Marking color : Silver print on a black sleeve

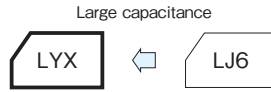

Specifications

Item	Performance	
Category temperature range (°C)	-25 to +105	
Tolerance at rated capacitance (%)	±20 (20°C, 120Hz)	
Leakage current (µA)	Less than 0.01CV or 5mA whichever is smaller (after 5 minutes) C : Rated capacitance (µF) ; V : Rated voltage (V) (20°C)	
Tangent of loss angle (tanδ)	0.20 (20°C, 120Hz)	
Endurance (105°C) (Applied ripple current)	Test time	5000 hours
	Leakage current	The initial specified value or less
	Percentage of capacitance change	Within ±20% of initial value
	Tangent of the loss angle	200% or less of the initial specified value
Shelf life (105°C)	Test time	1000 hours
	Leakage current	The initial specified value or less
	Percentage of capacitance change	Within ±20% of initial value
	Tangent of the loss angle	200% or less of the initial specified value
Applicable standards	JIS C5101-1, -4 1998 (IEC 60384-1 1992, -4 1995)	

Outline Drawing

Unit : mm

φD	36	51	64	77	90	101
F±1	12.7	22.0	28.2	31.4	31.4	41.5

Mounting Clamp

Unit : mm

Code J (2-legs)

φD	W1	W2	A	B
36	48	58	3.8	7
51	68	80	5	7
64	81	93	5	7
77	93.5	106	5	7
90	108	120.5	5	7

Code K (3-legs)

φD	R1	R2	A	B
51	31.8	36.5	5	7
64	38.1	42.6	5	7
77	44.5	49.2	5	7
90	50.8	55.6	5	7
101	57.5	63.5	6	8

φD	H
36	15
51~101	30

Part numbering system (example : 400V3300µF)

LYX	—	400	V	332	M	DD0	B	□
Series code		Rated voltage symbol		Rated capacitance symbol	Capacitance tolerance symbol	Casing symbol	Optional symbol	Clamp code

Coefficient of Frequency for Rated Ripple Current

Frequency (Hz)	50	120	300	1k	10k
Rated voltage (V)	0.80	1.00	1.10	1.30	1.40
350 to 450					

NOTE

Design, Specifications are subject to change without notice. Ask factory for technical specifications before purchase and/or use.

Standard Ratings

350V						400V					
Rated capacitance (μ F)	Case (mm)		Casing symbol	ESR	Rated ripple current (Arms)	Rated capacitance (μ F)	Case (mm)		Casing symbol	ESR	Rated ripple current (Arms)
	ϕ D	L		(m Ω max.)			ϕ D	L		(m Ω max.)	
1000	51	75	C75	259	3.9	1000	51	75	C75	215	3.9
1200	51	75	C75	215	4.2	1200	51	96	C96	179	4.6
1500	51	96	C96	172	5.2	1500	51	115	CB5	143	5.6
1800	51	96	C96	143	5.7	1800	51	130	CD0	119	6.4
2200	51	130	CD0	117	7.1	2200	64	96	D96	98	6.9
2700	64	96	D96	96	7.7	2700	64	115	DB5	80	8.2
3300	64	115	DB5	78	9.1	3300	64	130	DD0	65	9.5
3900	64	130	DD0	66	10.4	3900	64	155	DF5	55	11.1
4700	64	155	DF5	55	12.2		77	115	EB5	55	10.4
	77	115	EB5	55	11.5	4700	64	195	DJ5	46	13.4
5600	64	195	DJ5	46	14.6		77	130	ED0	46	12.0
	77	130	ED0	46	13.1	5600	64	195	DJ5	39	14.6
6800	77	155	EF5	38	15.5		77	155	EF5	39	14.0
8200	90	157	FF7	31	18.1	6800	90	157	FF7	32	16.5
10000	90	157	FF7	26	19.9	8200	90	157	FF7	26	18.1
12000	90	196	FJ6	22	23.8	10000	90	196	FJ6	22	21.7
15000	90	236	FN6	17	28.8	12000	90	236	FN6	18	25.8

450V					
Rated capacitance (μ F)	Case (mm)		Casing symbol	ESR	Rated ripple current (Arms)
	ϕ D	L		(m Ω max.)	
1000	51	96	C96	215	4.2
1200	51	115	CB5	179	5.0
1500	51	130	CD0	143	5.9
1800	64	96	D96	119	6.3
2200	64	115	DB5	98	7.4
2700	64	130	DD0	80	8.6
	77	115	EB5	80	8.7
3300	64	155	DF5	65	10.2
	77	130	ED0	65	10.1
3900	64	195	DJ5	55	12.3
4700	77	155	EF5	46	12.9
5600	77	195	EJ5	38	15.4
	90	157	FF7	38	14.9
6800	90	196	FJ6	32	18.0
8200	90	196	FJ6	27	19.8
10000	90	236	FN6	22	23.6

(Note) ESR : 20°C, 120Hz ; Rated ripple current : 105°C, 120Hz

Screw Terminal, Long Life capacitors

GREEN CAP 85°C 20000hours

- Screw Terminal, Long Life capacitors.
- Guarantees 20000 hours at 85°C.

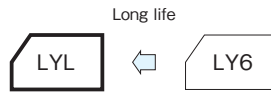

Marking color : Silver print on a black sleeve

Specifications

Item	Performance	
Category temperature range (°C)	-40 to +85	
Tolerance at rated capacitance (%)	±20 (20°C, 120Hz)	
Leakage current (µA)	Less than 0.01CV or 5mA whichever is smaller (after 5 minutes) C : Rated capacitance (µF) ; V : Rated voltage (V) (20°C)	
Tangent of loss angle (tanδ)	0.20 (20°C, 120Hz)	
Endurance (85°C) (Applied ripple current)	Test time	20000 hours
	Leakage current	The initial specified value or less
	Percentage of capacitance change	Within ±20% of initial value
	Tangent of the loss angle	200% or less of the initial specified value
Shelf life (85°C)	Test time	1000 hours
	Leakage current	The initial specified value or less
	Percentage of capacitance change	Within ±20% of initial value
	Tangent of the loss angle	200% or less of the initial specified value
Applicable standards	JIS C5101-1, -4 1998 (IEC 60384-1 1992, -4 1995)	

Outline Drawing

Unit : mm

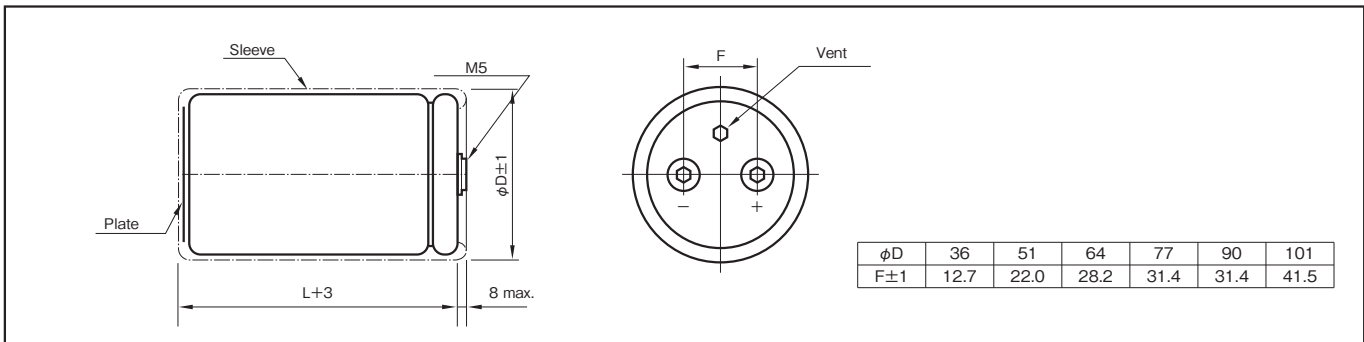

Mounting Clamp

Unit : mm

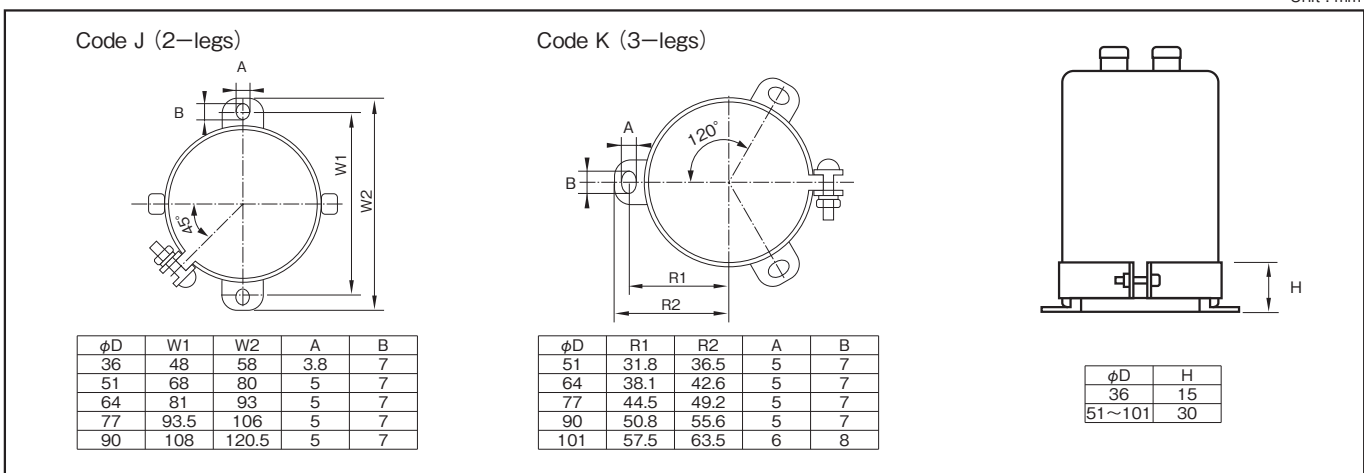

Part numbering system (example : 450V4700µF)

LYL	—	450	V	472	M	EF5	B	□
Series code		Rated voltage symbol		Rated capacitance symbol	Capacitance tolerance symbol	Casing symbol	Optional symbol	Clamp code

Coefficient of Frequency for Rated Ripple Current

Frequency (Hz)	50	120	300	1k	10k
Rated voltage (V)					
350 to 450	0.80	1.00	1.10	1.30	1.40

NOTE

Design, Specifications are subject to change without notice. Ask factory for technical specifications before purchase and/or use.

Standard Ratings

350V						400V					
Rated capacitance (μ F)	Case (mm)		Casing symbol	ESR	Rated ripple current (Arms)	Rated capacitance (μ F)	Case (mm)		Casing symbol	ESR	Rated ripple current (Arms)
	ϕ D	L		(m Ω max.)			ϕ D	L		(m Ω max.)	
1000	51	75	C75	259	3.9	1000	51	75	C75	215	3.9
1200	51	75	C75	215	4.2	1200	51	96	C96	179	4.6
1500	51	96	C96	172	5.2	1500	51	115	CB5	143	5.6
1800	51	96	C96	143	5.7	1800	51	130	CD0	119	6.4
2200	51	130	CD0	117	7.1	2200	64	96	D96	98	6.9
2700	64	96	D96	96	7.7	2700	64	115	DB5	80	8.2
3300	64	115	DB5	78	9.1	3300	64	130	DD0	65	9.5
3900	64	130	DD0	66	10.4	3900	64	155	DF5	55	11.1
4700	64	155	DF5	55	12.2		77	115	EB5	55	10.4
	77	115	EB5	55	11.5	4700	64	195	DJ5	46	13.4
5600	64	195	DJ5	46	14.6		77	130	ED0	46	12.0
	77	130	ED0	46	13.1	5600	64	195	DJ5	39	14.6
6800	77	155	EF5	38	15.5		77	155	EF5	39	14.0
8200	90	157	FF7	31	18.1	6800	90	157	FF7	32	16.5
10000	90	157	FF7	26	19.9	8200	90	157	FF7	26	18.1
12000	90	196	FJ6	22	23.8	10000	90	196	FJ6	22	21.7
15000	90	236	FN6	17	28.8	12000	90	236	FN6	18	25.8

450V					
Rated capacitance (μ F)	Case (mm)		Casing symbol	ESR	Rated ripple current (Arms)
	ϕ D	L		(m Ω max.)	
1000	51	96	C96	215	4.2
1200	51	115	CB5	179	5.0
1500	51	130	CD0	143	5.9
1800	64	96	D96	119	6.3
2200	64	115	DB5	98	7.4
2700	64	130	DD0	80	8.6
	77	115	EB5	80	8.7
3300	64	155	DF5	65	10.2
	77	130	ED0	65	10.1
3900	64	195	DJ5	55	12.3
4700	77	155	EF5	46	12.9
5600	77	195	EJ5	38	15.4
	90	157	FF7	38	14.9
6800	90	196	FJ6	32	18.0
8200	90	196	FJ6	27	19.8
10000	90	236	FN6	22	23.6

(Note) ESR : 20°C, 120Hz ; Rated ripple current : 85°C, 120Hz

Screw Terminal, Miniaturized, High Ripple capacitors

GREEN CAP 85°C 5000hours

- Screw Terminal, Miniaturized, High Ripple capacitors.
- Guarantees 5000 hours at 85°C.



Marking color : Silver print on a black sleeve

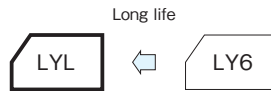

Specifications

Item	Performance	
Category temperature range (°C)	-25 to +85	
Tolerance at rated capacitance (%)	±20 (20°C, 120Hz)	
Leakage current (µA)	Less than 0.01CV or 5mA whichever is smaller (after 5 minutes) C : Rated capacitance (µF) ; V : Rated voltage (V) (20°C)	
Tangent of loss angle (tanδ)	0.20 (20°C, 120Hz)	
Endurance (85°C) (Applied ripple current)	Test time	5000 hours
	Leakage current	The initial specified value or less
	Percentage of capacitance change	Within ±20% of initial value
	Tangent of the loss angle	200% or less of the initial specified value
Shelf life (85°C)	Test time	1000 hours
	Leakage current	The initial specified value or less
	Percentage of capacitance change	Within ±20% of initial value
	Tangent of the loss angle	200% or less of the initial specified value
Applicable standards	JIS C5101-1, -4 1998 (IEC 60384-1 1992, -4 1995)	

Outline Drawing

Unit : mm

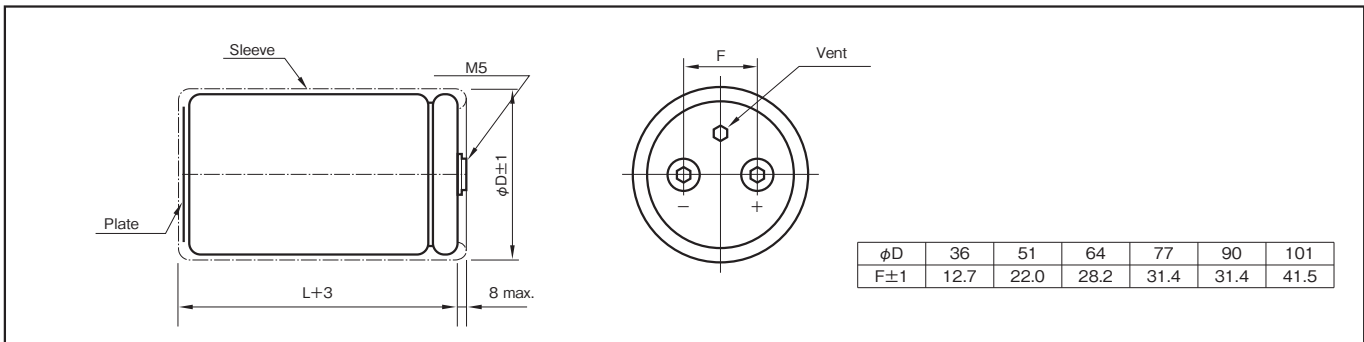

Mounting Clamp

Unit : mm

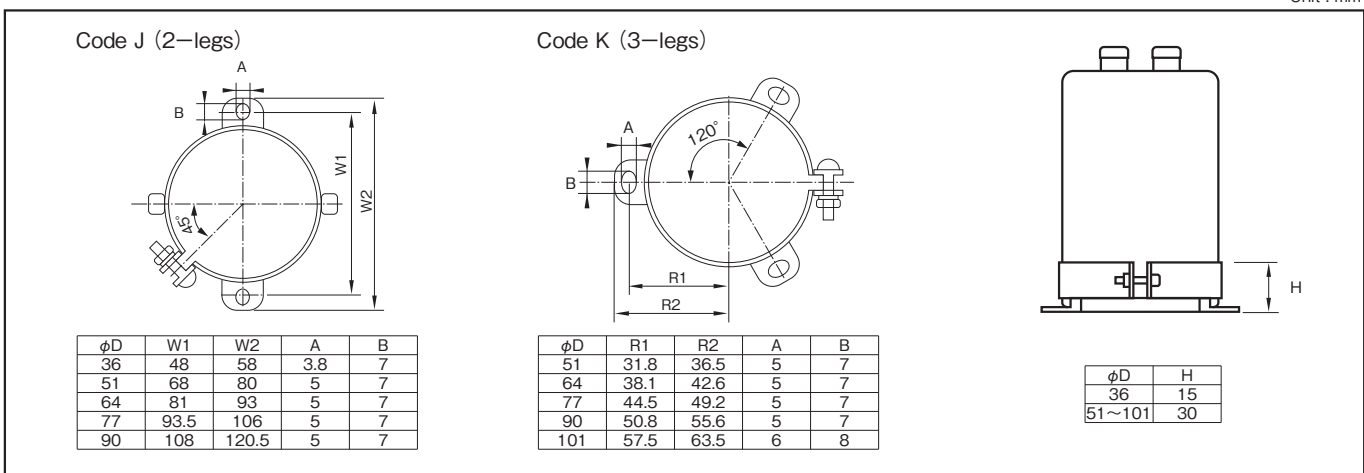

Part numbering system (example : 400V12000µF)

LY6	—	400	V	123	M	FF7	B	□
Series code		Rated voltage symbol		Rated capacitance symbol	Capacitance tolerance symbol	Casing symbol	Optional symbol	Clamp code

Coefficient of Frequency for Rated Ripple Current

Frequency (Hz)	50	120	300	1k	10k
Rated voltage (V)					
400 to 550	0.80	1.00	1.10	1.30	1.40

Standard Ratings

400V						450V					
Rated capacitance (μ F)	Case (mm)		Casing symbol	ESR	Rated ripple current (Arms)	Rated capacitance (μ F)	Case (mm)		Casing symbol	ESR	Rated ripple current (Arms)
	ϕ D	L		(m Ω max.)			ϕ D	L		(m Ω max.)	
2200	51	115	CB5	98	8.8	1800	51	115	CB5	119	7.6
2700	51	130	CD0	80	10.2	2200	51	130	CD0	98	8.8
3300	64	96	D96	65	11.0	2700	64	96	D96	80	9.5
3900	64	115	DB5	55	12.8	3300	64	115	DB5	65	11.2
4700	64	130	DD0	46	14.8	3900	64	130	DD0	55	12.8
5600	77	115	EB5	38	16.2	4700	77	115	EB5	46	14.1
6800	77	130	ED0	32	18.7	5600	77	130	ED0	38	16.2
8200	77	155	EF5	26	22.0	6800	77	155	EF5	32	19.1
10000	77	195	EJ5	22	26.7	8200	77	195	EJ5	26	23.0
	90	131	FD1	22	24.2		90	131	FD1	26	21.0
12000	90	157	FF7	18	28.5	10000	90	171	FH1	22	25.7
15000	90	196	FJ6	14	34.8	12000	90	196	FJ6	18	29.7
18000	90	236	FN6	12	41.2		101	175	GH5	18	29.3
22000	101	237	GN7	10	47.0	15000	90	236	FN6	14	35.9
—	—	—	—	—	—		101	195	GJ5	14	24.2
—	—	—	—	—	—	18000	101	237	GN7	12	40.5

500V						550V					
Rated capacitance (μ F)	Case (mm)		Casing symbol	ESR	Rated ripple current (Arms)	Rated capacitance (μ F)	Case (mm)		Casing symbol	ESR	Rated ripple current (Arms)
	ϕ D	L		(m Ω max.)			ϕ D	L		(m Ω max.)	
1200	51	115	CB5	215	6.2	1000	51	130	CD0	258	5.9
	64	96	D96	215	6.3	1200	64	115	DB5	215	6.8
1500	51	130	CD0	172	7.3	1500	64	130	DD0	172	8.0
	64	96	D96	172	7.1	1800	77	115	EB5	143	8.7
1800	64	115	DB5	143	8.3	2200	77	130	ED0	117	10.1
2200	64	130	DD0	117	9.6	2700	77	155	EF5	96	12.0
2700	77	115	EB5	96	10.7	3300	77	155	EF5	78	13.3
3300	77	130	ED0	78	12.4	3900	90	157	FF7	66	15.5
3900	77	155	EF5	66	14.4	4700	90	171	FH1	55	17.6
4700	77	171	EH1	55	16.5	5600	90	196	FJ6	46	20.3
	90	131	FD1	55	15.8	6800	90	236	FN6	38	24.1
5600	77	195	EJ5	46	19.0	8200	101	237	GN7	31	27.3
	90	157	FF7	46	18.6						
6800	90	171	FH1	38	21.2						
8200	90	196	FJ6	31	24.5						
	101	175	GH5	31	24.2						
10000	90	236	FN6	26	29.3						
	101	195	GJ5	26	27.9						
12000	101	237	GN7	22	33.1						

(Note) ESR : 20°C, 120Hz ; Rated ripple current : 85°C, 120Hz

Screw Terminal, Standard capacitors

GREEN CAP 85°C 2000hours

- Screw Terminal, Standard capacitors.
- Guarantees 2000 hours at 85°C.

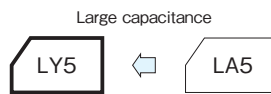

Marking color : Silver print on a black sleeve

Specifications

Item	Performance	
Category temperature range (°C)	-40 to +85	-25 to +85
Rated voltage (V)	10 to 250	350 to 500
Tolerance at rated capacitance (%)	±20 (20°C, 120Hz)	
Leakage current (µA)	Less than 0.01CV or 5mA whichever is smaller (after 5 minutes) C : Rated capacitance (µF) ; V : Rated voltage (V) (20°C)	
Tangent of loss angle (tanδ)	0.20 (20°C, 120Hz)	
Endurance (85°C) (Applied ripple current)	Test time	2000 hours
	Leakage current	The initial specified value or less
	Percentage of capacitance change	Within ±20% of initial value
	Tangent of the loss angle	200% or less of the initial specified value
Shelf life (85°C)	Test time	1000 hours
	Leakage current	The initial specified value or less
	Percentage of capacitance change	Within ±20% of initial value
	Tangent of the loss angle	200% or less of the initial specified value
Applicable standards	JIS C5101-1, -4 1998 (IEC 60384-1 1992, -4 1995)	

Outline Drawing

Unit : mm

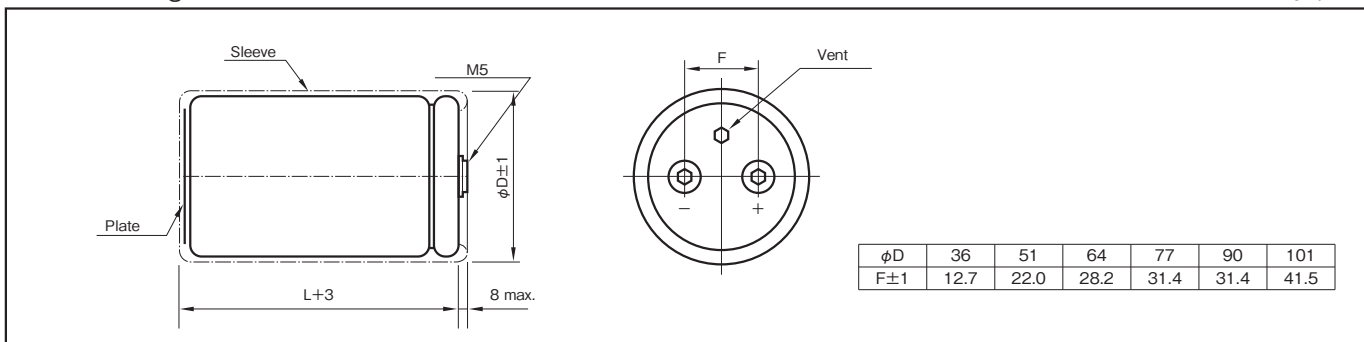

Mounting Clamp

Unit : mm

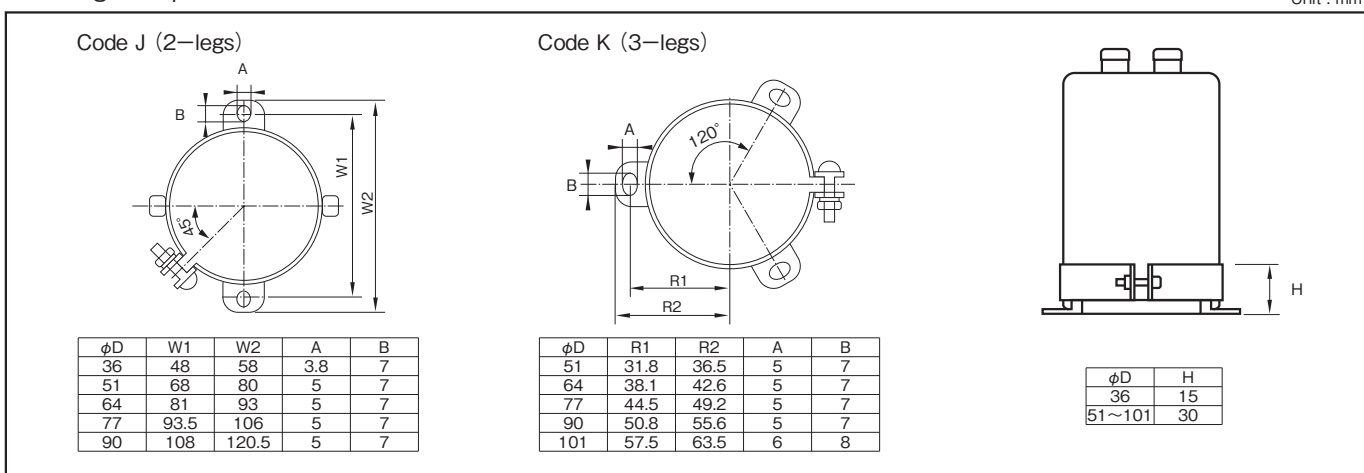

Part numbering system (example : 50V4700µF)

LY5	—	50	V	473	M	CB5	B	□
Series code		Rated voltage symbol		Rated capacitance symbol	Capacitance tolerance symbol	Casing symbol	Optional symbol	Clamp code

Coefficient of Frequency for Rated Ripple Current

Rated voltage (V)	Frequency (Hz)				
	50	120	300	1k	10k
10 to 50	0.95	1.00	1.04	1.10	1.15
63 to 160	0.95	1.00	1.06	1.16	1.30
200 to 500	0.80	1.00	1.10	1.25	1.50

NOTE

Design, Specifications are subject to change without notice. Ask factory for technical specifications before purchase and/or use.

Standard Ratings

10V						16V						25V					
Rated capacitance (μF)	tan δ	Case (mm)		Casing symbol	Rated ripple current (Arms)	Rated capacitance (μF)	tan δ	Case (mm)		Casing symbol	Rated ripple current (Arms)	Rated capacitance (μF)	tan δ	Case (mm)		Casing symbol	Rated ripple current (Arms)
		φD	L					φD	L					φD	L		
33,000	0.80	36	53	A53	4.3	22,000	0.60	36	53	A53	4.1	15,000	0.50	36	53	A53	3.7
39,000	0.80	36	53	A53	4.7	27,000	0.60	36	53	A53	4.5	18,000	0.50	36	53	A53	4.1
47,000	0.80	36	65	A65	5.2	33,000	0.60	36	53	A53	5.0	22,000	0.50	36	53	A53	4.5
56,000	0.80	36	83	A83	6.1	39,000	0.60	36	65	A65	5.9	27,000	0.50	36	65	A65	5.0
68,000	0.80	36	83	A83	6.7	47,000	0.60	36	83	A83	6.4	33,000	0.50	36	83	A83	5.9
82,000	0.80	36	100	AA0	7.7	56,000	0.60	36	83	A83	7.3	39,000	0.50	36	83	A83	6.7
100,000	0.80	36	101	AA1	8.8	68,000	0.60	36	100	AA0	8.4	47,000	0.50	36	100	AA0	7.7
120,000	0.80	36	121	AC1	10.0	82,000	0.80	36	100	AA0	8.3	56,000	0.60	36	100	AA0	7.9
150,000	1.00	36	121	AC1	10.8	100,000	0.80	36	121	AC1	9.5	68,000	0.60	36	121	AC1	9.2
180,000	1.00	51	96	C96	12.0	120,000	0.80	36	121	AC1	10.9	82,000	0.60	36	121	AC1	10.4
220,000	1.50	51	121	CC1	11.2	150,000	1.00	51	96	C96	11.3	100,000	0.60	51	96	C96	10.3
270,000	1.50	51	122	CC2	12.8	180,000	1.00	51	115	CB5	12.8	120,000	0.80	51	115	CB5	11.7
330,000	1.50	64	96	D96	15.3	220,000	1.00	51	130	CD0	15.3	150,000	0.80	51	130	CD0	14.1
390,000	1.50	64	115	DB5	17.3	270,000	1.00	64	96	D96	17.6	180,000	0.80	64	96	D96	15.7
470,000	2.00	64	130	DD0	16.7	330,000	1.50	64	115	DB5	16.8	220,000	1.00	64	115	DB5	16.1
560,000	2.00	77	115	EB5	19.0	390,000	1.50	64	130	DD0	18.3	270,000	1.00	64	130	DD0	18.6
680,000	2.00	77	130	ED0	21.7	470,000	1.50	77	115	EB5	21.3	330,000	1.00	64	155	DF5	21.9
820,000	2.00	77	155	EF5	24.7	560,000	1.50	77	130	ED0	23.6	390,000	1.20	77	115	EB5	22.0
—	—	—	—	—	—	680,000	1.50	77	155	EF5	27.6	470,000	1.20	77	155	EF5	25.6
—	—	—	—	—	—	820,000	2.00	90	157	FF7	27.1	560,000	1.20	90	131	FD1	27.9
—	—	—	—	—	—	—	—	—	—	—	—	680,000	1.20	90	157	FF7	32.5

35V						50V						63V					
Rated capacitance (μF)	tan δ	Case (mm)		Casing symbol	Rated ripple current (Arms)	Rated capacitance (μF)	tan δ	Case (mm)		Casing symbol	Rated ripple current (Arms)	Rated capacitance (μF)	tan δ	Case (mm)		Casing symbol	Rated ripple current (Arms)
		φD	L					φD	L					φD	L		
10,000	0.40	36	53	A53	3.4	5,600	0.30	36	53	A53	3.0	3,900	0.25	36	53	A53	2.7
12,000	0.40	36	53	A53	3.7	6,800	0.30	36	53	A53	3.3	4,700	0.25	36	53	A53	3.0
15,000	0.40	36	65	A65	4.2	8,200	0.30	36	53	A53	3.6	5,600	0.25	36	53	A53	3.3
18,000	0.40	36	83	A83	4.7	10,000	0.30	36	65	A65	4.0	6,800	0.25	36	65	A65	3.6
22,000	0.40	36	83	A83	5.7	12,000	0.30	36	83	A83	4.7	8,200	0.25	36	83	A83	4.3
27,000	0.40	36	100	AA0	6.3	15,000	0.30	36	83	A83	5.5	10,000	0.25	36	83	A83	4.9
33,000	0.40	36	100	AA0	7.2	18,000	0.30	36	100	AA0	6.2	12,000	0.25	36	100	AA0	5.6
39,000	0.50	36	121	AC1	8.3	22,000	0.40	36	121	AC1	6.3	15,000	0.30	36	100	AA0	5.9
47,000	0.50	51	96	C96	8.7	27,000	0.40	36	121	AC1	7.1	18,000	0.30	36	121	AC1	6.7
56,000	0.60	51	96	C96	8.6	33,000	0.40	51	96	C96	8.2	22,000	0.30	36	121	AC1	7.8
68,000	0.60	51	115	CB5	9.8	39,000	0.50	51	96	C96	8.1	27,000	0.40	51	96	C96	7.4
82,000	0.60	64	96	D96	11.6	47,000	0.50	51	115	CB5	9.3	33,000	0.40	51	96	C96	8.4
100,000	0.60	64	115	DB5	13.3	56,000	0.50	64	96	D96	10.5	39,000	0.40	51	115	CB5	9.5
120,000	0.80	64	121	DC1	14.8	68,000	0.50	64	96	D96	12.0	47,000	0.40	51	130	CD0	11.3
150,000	0.80	64	130	DD0	14.9	82,000	0.50	64	115	DB5	13.7	56,000	0.40	64	115	DB5	12.8
180,000	0.80	77	115	EB5	17.0	100,000	0.60	77	115	EB5	14.7	68,000	0.50	64	121	DC1	12.7
220,000	0.80	77	130	ED0	20.0	120,000	0.60	77	115	EB5	16.7	82,000	0.50	64	130	DD0	14.5
270,000	1.00	77	155	EF5	20.3	150,000	0.60	77	130	ED0	19.3	100,000	0.50	77	115	EB5	16.7
330,000	1.00	90	131	FD1	23.5	180,000	0.60	77	155	EF5	21.9	120,000	0.50	77	130	ED0	18.9
390,000	1.00	90	157	FF7	26.4	220,000	0.60	90	131	FD1	21.4	150,000	0.50	77	155	EF5	22.4
470,000	1.00	90	157	FF7	29.6	270,000	0.60	90	157	FF7	24.6	180,000	0.60	90	131	FD1	22.4
—	—	—	—	—	—	—	—	—	—	—	—	220,000	0.60	90	157	FF7	26.2

80V						100V					
Rated capacitance (μF)	tan δ	Case (mm)		Casing symbol	Rated ripple current (Arms)	Rated capacitance (μF)	tan δ	Case (mm)		Casing symbol	Rated ripple current (Arms)
		φD	L					φD	L		
3,300	0.25	36	53	A53	2.5	1,800	0.25	36	53	A53	1.9
3,900	0.25	36	53	A53	2.8	2,200	0.25	36	53	A53	2.1
4,700	0.25	36	65	A65	3.0	2,700	0.25	36	53	A53	2.3
5,600	0.25	36	83	A83	3.6	3,300	0.25	36	65	A65	2.6
6,800	0.25	36	83	A83	3.9	3,900	0.25	36	83	A83	3.0
8,200	0.25	36	83	A83	4.5	4,700	0.25	36	83	A83	3.5
10,000	0.25	36	100	AA0	5.2	5,600	0.25	36	100	AA0	3.9
12,000	0.25	36	100	AA0	5.9	6,800	0.25	36	100	AA0	4.5
15,000	0.25	36	121	AC1	6.8	8,200	0.25	36	121	AC1	5.1
18,000	0.25	36	121	AC1	7.8	10,000	0.25	36	121	AC1	5.9
22,000	0.30	51	96	C96	8.0	12,000	0.25	51	75	C75	6.4
27,000	0.30	51	96	C96	9.2	15,000	0.25	51	96	C96	7.0
33,000	0.30	51	115	CB5	10.5	18,000	0.25	51	115	CB5	8.3
39,000	0.30	51	130	CD0	12.0	22,000	0.25	51	130	CD0	10.0
47,000	0.30	64	115	DB5	13.6	27,000	0.25	64	115	DB5	11.5
56,000	0.40	64	130	DD0	13.4	33,000	0.25	64	130	DD0	11.9
68,000	0.40	77	115	EB5	15.4	39,000	0.25	77	115	EB5	13.4
82,000	0.40	77	130	ED0	17.5	47,000	0.35	77	130	ED0	14.2
100,000	0.40	77	155	EF5	20.5	56,000	0.35	77	155	EF5	16.0
120,000	0.40	90	131	FD1	22.4	68,000	0.35	90	131	FD1	18.8
150,000	0.40	90	157	FF7	26.5	82,000	0.35	90	157	FF7	20.5
—	—	—	—	—	—	100,000	0.35	90	171	FH1	24.0

(Note) tan δ : 20°C, 120Hz ; Rated ripple current : 85°C, 120Hz

Standard Ratings

160V						200V						250V					
Rated capacitance (μF)	tan δ	Case (mm)		Casing symbol	Rated ripple current (Arms)	Rated capacitance (μF)	tan δ	Case (mm)		Casing symbol	Rated ripple current (Arms)	Rated capacitance (μF)	tan δ	Case (mm)		Casing symbol	Rated ripple current (Arms)
		φD	L					φD	L					φD	L		
3,300	0.25	36	121	AC1	5.2	2,200	0.25	36	100	AA0	3.9	1,500	0.25	36	100	AA0	3.2
4,700	0.25	51	75	C75	5.9	3,300	0.25	51	75	C75	4.9	2,200	0.25	51	75	C75	4.0
5,600	0.25	51	96	C96	7.0	4,700	0.25	51	96	C96	6.4	3,300	0.25	51	96	C96	5.4
6,800	0.25	51	96	C96	7.8	5,600	0.25	51	115	CB5	7.6	4,700	0.25	64	96	D96	7.1
10,000	0.25	64	96	D96	10.4	6,800	0.25	51	130	CD0	8.8	6,800	0.25	64	115	DB5	9.1
12,000	0.25	51	120	CC0	11.3	8,200	0.25	64	96	D96	9.4	8,200	0.25	64	115	DB5	10.0
15,000	0.25	64	130	DD0	14.3	10,000	0.25	64	96	D96	10.4	10,000	0.25	64	130	DD0	11.7
18,000	0.25	64	130	DD0	15.6	15,000	0.25	77	96	E96	14.4	15,000	0.25	77	130	ED0	15.1
22,000	0.25	77	130	ED0	18.3	18,000	0.25	77	130	ED0	16.5	18,000	0.25	77	155	EF5	17.7
33,000	0.25	90	131	FD1	23.8	22,000	0.25	77	150	EF0	19.6	22,000	0.25	90	157	FF7	20.9
39,000	0.25	90	157	FF7	27.9	33,000	0.25	90	157	FF7	25.3	—	—	—	—	—	—

350V						400V						450V					
Rated capacitance (μF)	tan δ	Case (mm)		Casing symbol	Rated ripple current (Arms)	Rated capacitance (μF)	tan δ	Case (mm)		Casing symbol	Rated ripple current (Arms)	Rated capacitance (μF)	tan δ	Case (mm)		Casing symbol	Rated ripple current (Arms)
		φD	L					φD	L					φD	L		
470	0.20	36	83	A83	2.2	470	0.20	36	83	A83	2.2	470	0.20	36	83	A83	2.2
680	0.20	36	83	A83	2.6	680	0.20	36	100	AA0	2.8	680	0.20	36	100	AA0	2.8
1,000	0.20	36	100	AA0	3.4	1,000	0.20	51	75	C75	3.5	820	0.20	51	75	C75	3.2
1,500	0.20	51	75	C75	4.3	1,200	0.20	51	75	C75	3.8	1,000	0.20	51	75	C75	3.5
1,800	0.20	51	96	C96	5.1	1,500	0.20	51	96	C96	4.7	1,200	0.20	51	96	C96	4.2
2,200	0.20	51	96	C96	5.7	1,800	0.20	51	96	C96	5.2	1,500	0.20	51	115	CB5	5.0
2,700	0.20	51	130	CD0	7.1	2,200	0.20	51	120	CC0	6.4	1,800	0.20	51	130	CD0	5.9
3,300	0.20	51	130	CD0	7.9	2,700	0.20	64	96	D96	7.0	2,200	0.20	64	96	D96	6.3
3,900	0.20	64	115	DB5	9.0	3,300	0.20	64	115	DB5	8.2	2,700	0.20	64	115	DB5	7.5
4,700	0.20	64	130	DD0	10.3	3,900	0.20	64	130	DD0	9.4	3,300	0.20	64	130	DD0	8.7
5,600	0.20	77	115	EB5	11.4	4,700	0.20	77	115	EB5	10.4	3,900	0.20	77	115	EB5	9.5
6,800	0.20	77	130	ED0	13.1	5,600	0.20	77	130	ED0	11.9	4,700	0.20	77	130	ED0	10.9
8,200	0.20	77	155	EF5	15.4	6,800	0.20	77	155	EF5	14.1	5,600	0.20	77	155	EF5	12.8
10,000	0.20	90	157	FF7	18.1	8,200	0.20	90	157	FF7	16.4	6,800	0.20	90	157	FF7	15.0
12,000	0.20	90	157	FF7	20.0	10,000	0.20	90	157	FF7	18.3	8,200	0.20	90	157	FF7	16.5
15,000	0.20	90	196	FJ6	24.5	12,000	0.20	90	196	FJ6	21.8	10,000	0.20	90	196	FJ6	20.0
18,000	0.20	90	236	FN6	28.8	15,000	0.20	90	236	FN6	26.3	12,000	0.20	90	236	FN6	23.6

500V					
Rated capacitance (μF)	tan δ	Case (mm)		Casing symbol	Rated ripple current (Arms)
		φD	L		
1,000	0.25	51	115	CB5	4.6
1,500	0.25	64	96	D96	5.7
2,200	0.25	64	130	DD0	6.9
2,700	0.25	77	115	EB5	8.1
3,300	0.25	77	130	ED0	9.6
3,900	0.25	77	130	ED0	10.8
4,700	0.25	77	155	EF5	12.1
5,600	0.25	90	157	FF7	13.8
6,800	0.25	90	171	FH1	15.8
8,200	0.25	77	220	EM0	17.2
10,000	0.25	90	236	FN6	22.1

(Note) tan δ : 20°C, 120Hz ; Rated ripple current : 85°C, 120Hz

NOTE

Design, Specifications are subject to change without notice.
Ask factory for technical specifications before purchase and/or use.

Aluminum Electrolytic Capacitors for Audio

Chip Type Audio Use Capacitors

GREEN CAP

SMD

For audio

- Audio grade surface mount product with completely new components using synthetic mica paper for the separator.
- Both quality sense and sound field that could not be realized by the surface mount products are reproducible.



Marking color : Black print (except height : 10mm)
White print on a brown sleeve (φ8×10L, φ10×10L)

Specifications

Item	Performance							
Category temperature range (°C)	-40 to +85							
Tolerance at rated capacitance (%)	±20 (20°C, 120Hz)							
Leakage current (μA)	Less than 0.01CV or 3 whichever is larger (after 2 minutes) C : Rated capacitance (μF) ; V : Rated voltage (V) (20°C)							
Tangent of loss angle (tanδ)	Rated voltage (V)	6.3	10	16	25	35	50	
	tanδ (max.)	0.28	0.24	0.20	0.14	0.12	0.10	
Characteristics at high and low temperature	Impedance ratio (max.)	Z-25°C/Z+20°C	3	3	2	2	2	
		Z-40°C/Z+20°C	8	5	4	3	3	
Endurance (85°C) (Applied ripple current)	Test time	2000 hours						
	Leakage current	The initial specified value or less						
	Percentage of capacitance change	Within ±20% of initial value						
	Tangent of the loss angle	200% or less of the initial specified value						
Shelf life (85°C)	Test time : 1000 hours; other items are the same as those for the endurance. Voltage application treatment							
Applicable standards	JIS C5101-1 1998, -18 1999 (IEC 60384-1 1992, -18 1993)							

Outline Drawing

Unit : mm

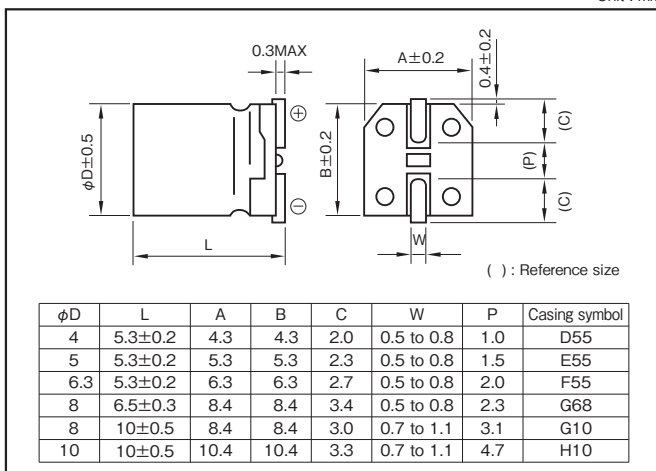

Coefficient of Frequency for Rated Ripple Current

Frequency (Hz)	50	120	1k	10k-100k
Rated voltage (V)				
6.3 to 16	0.80	1	1.15	1.25
25 to 35	0.80	1	1.25	1.40
50	0.80	1	1.35	1.50

Part numbering system (example : 16V470μF)



• Soldering conditions are described on page 13. • Land pattern size are described on page 11. • The taping specifications are described on page 14.

Standard Ratings

Rated voltage (V)	6.3		10		16		25		35		50	
	Case	Rated ripple current	Case	Rated ripple current	Case	Rated ripple current	Case	Rated ripple current	Case	Rated ripple current	Case	Rated ripple current
Rated capacitance (μF)	φD×L (mm)	(mArms)	φD×L (mm)	(mArms)	φD×L (mm)	(mArms)	φD×L (mm)	(mArms)	φD×L (mm)	(mArms)	φD×L (mm)	(mArms)
0.22	—	—	—	—	—	—	—	—	—	—	4×5.3	5
0.33	—	—	—	—	—	—	—	—	—	—	4×5.3	6
0.47	—	—	—	—	—	—	—	—	—	—	4×5.3	7
1	—	—	—	—	—	—	—	—	—	—	4×5.3	10
2.2	—	—	—	—	—	—	—	—	—	—	4×5.3	15
3.3	—	—	—	—	—	—	—	—	—	—	4×5.3	19
4.7	—	—	—	—	4×5.3	18	4×5.3	19	4×5.3	20	5×5.3	26
10	—	—	4×5.3	23	4×5.3	26	5×5.3	32	5×5.3	34	6.3×5.3	44
22	4×5.3	31	5×5.3	40	5×5.3	44	6.3×5.3	55	6.3×5.3	59	8×6.5	124
33	5×5.3	44	5×5.3	49	6.3×5.3	63	6.3×5.3	67	8×6.5	124	8×6.5	124
47	5×5.3	53	6.3×5.3	68	6.3×5.3	76	8×6.5	124	8×6.5	124	8×10	200
100	6.3×5.3	90	6.3×5.3	99	8×6.5	124	8×6.5	137	8×10	200	10×10	366
220	8×6.5	149	8×6.5	149	8×10	200	8×10	235	10×10	366	—	—
330	8×6.5	160	8×10	226	8×10	245	10×10	366	—	—	—	—
470	8×10	251	10×10	366	10×10	366	—	—	—	—	—	—
1000	10×10	423	—	—	—	—	—	—	—	—	—	—

(Note) Rated ripple current : 85°C, 120Hz.

NOTE

Design, Specifications are subject to change without notice.
Ask factory for technical specifications before purchase and/or use.

Chip Type, For Audio, High Grade (SILMIC)

GREEN CAP SMD For audio

- Silk fiber paper products used surface mount device.
- Completely new audio products for the high-grade paper using silk fiber paper.
- Silk "flexibility" to reduce the vibration energy of the music, in the sense of high-frequency peak, a significant decrease in roughness of the midrange and bass increase.

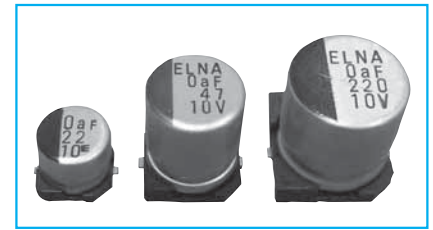

Marking color : Black print

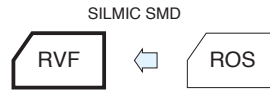

Specifications

Item	Performance											
Category temperature range (°C)	-40 to +85											
Tolerance at rated capacitance (%)	±20 (20°C, 120Hz)											
Leakage current (µA)	Less than 0.01CV or 3 whichever is larger (after 2 min.) C : Rated capacitance (µF) , V : Rated voltage (V) (20°C)											
Tangent of loss angle (tanδ)	<table border="1"> <tr> <th>Rated voltage (V)</th> <td>10</td> <td>16</td> <td>50</td> </tr> <tr> <td>tanδ (max.)</td> <td>0.32</td> <td>0.26</td> <td>0.12</td> </tr> </table> (20°C, 120Hz)	Rated voltage (V)	10	16	50	tanδ (max.)	0.32	0.26	0.12			
Rated voltage (V)	10	16	50									
tanδ (max.)	0.32	0.26	0.12									
Characteristics at high and low temperature	<table border="1"> <tr> <th>Rated voltage (V)</th> <td>10</td> <td>16</td> <td>50</td> </tr> <tr> <td rowspan="2">Impedance ratio (max.)</td> <td>Z-25°C/Z+20°C</td> <td>3</td> <td>2</td> </tr> <tr> <td>Z-40°C/Z+20°C</td> <td>8</td> <td>4</td> </tr> </table> (120Hz)	Rated voltage (V)	10	16	50	Impedance ratio (max.)	Z-25°C/Z+20°C	3	2	Z-40°C/Z+20°C	8	4
Rated voltage (V)	10	16	50									
Impedance ratio (max.)	Z-25°C/Z+20°C	3	2									
	Z-40°C/Z+20°C	8	4									
Endurance (85°C)	<table border="1"> <tr> <td>Test time</td> <td>2000 hours</td> </tr> <tr> <td>Leakage current</td> <td>The initial specified value or less</td> </tr> <tr> <td>Percentage of capacitance change</td> <td>Within ±20% of initial value</td> </tr> <tr> <td>Tangent of the loss angle</td> <td>200% or less of the initial specified value</td> </tr> </table>	Test time	2000 hours	Leakage current	The initial specified value or less	Percentage of capacitance change	Within ±20% of initial value	Tangent of the loss angle	200% or less of the initial specified value			
Test time	2000 hours											
Leakage current	The initial specified value or less											
Percentage of capacitance change	Within ±20% of initial value											
Tangent of the loss angle	200% or less of the initial specified value											
Shelf life (85°C)	Test time : 500 hours ; other items are the same as those for the endurance. Voltage application treatment : According to JIS C5101-1											
Applicable standards	JIS C5101-1 1998, -18 1999 (IEC 60384-1 1992, -18 1993)											

Outline Drawing

Unit : mm

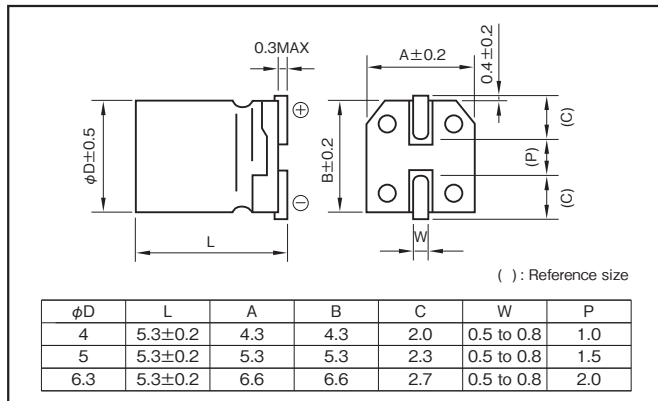

- Soldering conditions are described on page 13.
- Land pattern size are described on page 11.
- The taping specifications are described on page 14.

Coefficient of Frequency for Rated Ripple Current

Rated voltage (V) \ Frequency (Hz)	50	120	1k	10k-100k
10 to 16	0.80	1	1.15	1.25
50	0.80	1	1.35	1.50

Part numbering system (example : 16V10µF)

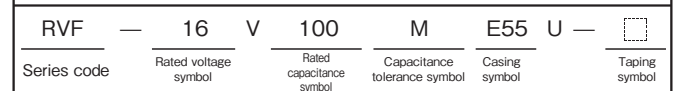

Standard Ratings

Rated capacitance (µF)	10		16		50	
	Case	Rated ripple current (mArms)	Case	Rated ripple current (mArms)	Case	Rated ripple current (mArms)
0.33	—	—	—	—	4×5.3	4
0.47	—	—	—	—	4×5.3	5
1	—	—	—	—	4×5.3	7
2.2	—	—	—	—	5×5.3	11
3.3	—	—	—	—	6.3×5.3	16
4.7	—	—	4×5.3	10	8×10	28
10	5×5.3	15	5×5.3	16	8×10	41
22	6.3×5.3	25	6.3×5.3	28	—	—
33	6.3×5.3	31	8×10	50	—	—
47	8×10	54	8×10	60	—	—
100	8×10	79	8×10	87	—	—

(Note) Rated ripple current : 85°C, 120Hz.

NOTE

Design, Specifications are subject to change without notice.
Ask factory for technical specifications before purchase and/or use.

Chip Type, For Audio, High Grade

GREEN CAP SMD 105°C 2000hours For audio

- New developed Al-Foil and Electrolyte for Audio grade allow lower distortion.
- New range of bright and smooth sound is achieved in SMD area.
- Guarantees 2000 hours 105°C.

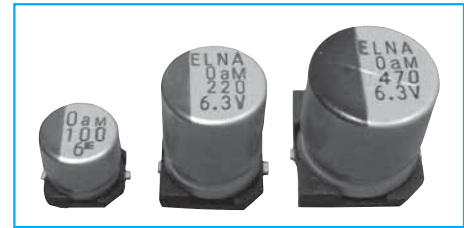
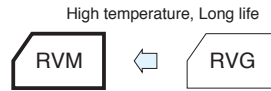

Marking color : Black print

Specifications

Item	Performance																				
Category temperature range (°C)	-55 to +105																				
Tolerance at rated capacitance (%)	±20 (20°C, 120Hz)																				
Leakage current (µA)	Less than 0.01CV or 3 whichever is larger (after 2 min.) C : Rated capacitance (µF), V: Rated voltage (V) (20°C)																				
Tangent of loss angle (tanδ)	<table border="1"> <thead> <tr> <th>Rated voltage (V)</th> <th>6.3</th> <th>10</th> <th>16</th> <th>25</th> <th>35</th> <th>50</th> </tr> </thead> <tbody> <tr> <td>tanδ (max.)</td> <td>0.28</td> <td>0.24</td> <td>0.20</td> <td>0.16</td> <td>0.13</td> <td>0.12</td> </tr> </tbody> </table> <p>(20°C, 120Hz)</p>	Rated voltage (V)	6.3	10	16	25	35	50	tanδ (max.)	0.28	0.24	0.20	0.16	0.13	0.12						
Rated voltage (V)	6.3	10	16	25	35	50															
tanδ (max.)	0.28	0.24	0.20	0.16	0.13	0.12															
Characteristics at high and low temperature	<table border="1"> <thead> <tr> <th>Rated voltage (V)</th> <th>6.3</th> <th>10</th> <th>16</th> <th>25</th> <th>35</th> <th>50</th> </tr> </thead> <tbody> <tr> <td rowspan="2">Impedance ratio (max.)</td> <td>Z-25°C/Z+20°C</td> <td>2</td> <td>2</td> <td>2</td> <td>2</td> <td>2</td> </tr> <tr> <td>Z-40°C/Z+20°C</td> <td>8</td> <td>4</td> <td>4</td> <td>3</td> <td>3</td> </tr> </tbody> </table> <p>(120Hz)</p>	Rated voltage (V)	6.3	10	16	25	35	50	Impedance ratio (max.)	Z-25°C/Z+20°C	2	2	2	2	2	Z-40°C/Z+20°C	8	4	4	3	3
Rated voltage (V)	6.3	10	16	25	35	50															
Impedance ratio (max.)	Z-25°C/Z+20°C	2	2	2	2	2															
	Z-40°C/Z+20°C	8	4	4	3	3															
Endurance (85°C)	<table border="1"> <tbody> <tr> <td>Test time</td> <td>2000 hours</td> </tr> <tr> <td>Leakage current</td> <td>The initial specified value or less</td> </tr> <tr> <td>Percentage of capacitance change</td> <td>Within ±30% of initial value</td> </tr> <tr> <td>Tangent of the loss angle</td> <td>300% or less of the initial specified value</td> </tr> </tbody> </table>	Test time	2000 hours	Leakage current	The initial specified value or less	Percentage of capacitance change	Within ±30% of initial value	Tangent of the loss angle	300% or less of the initial specified value												
Test time	2000 hours																				
Leakage current	The initial specified value or less																				
Percentage of capacitance change	Within ±30% of initial value																				
Tangent of the loss angle	300% or less of the initial specified value																				
Shelf life (85°C)	Test time : 1000 hours; other items are the same as those for the endurance. Voltage application treatment : According to JIS C5101-1																				
Applicable standards	JIS C5101-1 1998, -18 1999 (IEC 60384-1 1992, -18 1993)																				

Outline Drawing

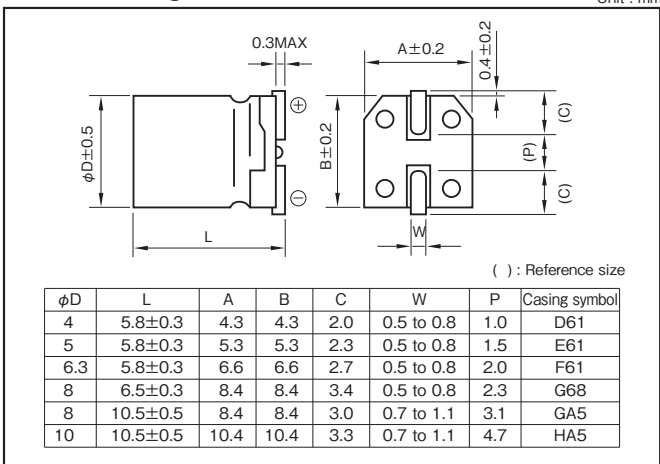

Coefficient of Frequency for Rated Ripple Current

Rated voltage (V)	Frequency (Hz)			
	50	120	1k	10k · 100k
6.3 to 16	0.80	1.00	1.15	1.25
25 to 35	0.80	1.00	1.25	1.40
50	1 to 3.3µF	0.50	1.00	1.35
	4.7µF to	0.70	1.00	1.35

Part numbering system (example : 6.3V220µF)

RVM	6	V	221	M	G68	P U	R2
Series code	Rated voltage symbol		Rated capacitance symbol	Capacitance tolerance symbol	Casing symbol		Taping symbol

- Soldering conditions are described on page 13.
- Land pattern size are described on page 11.
- The taping specifications are described on page 14.

Standard Ratings

Rated voltage (V)	6.3		10		16		25		35		50	
	Case φD×L (mm)	Rated ripple current (mArms)	Case φD×L (mm)	Rated ripple current (mArms)	Case φD×L (mm)	Rated ripple current (mArms)	Case φD×L (mm)	Rated ripple current (mArms)	Case φD×L (mm)	Rated ripple current (mArms)	Case φD×L (mm)	Rated ripple current (mArms)
1	—	—	—	—	—	—	—	—	—	—	4×5.8	7
2.2	—	—	—	—	—	—	—	—	—	—	4×5.8	10
3.3	—	—	—	—	—	—	—	—	—	—	4×5.8	12
4.7	—	—	—	—	4×5.8	11	4×5.8	13	4×5.8	14	5×5.8	17
10	—	—	4×5.8	15	4×5.8	17	5×5.8	21	5×5.8	24	6.3×5.8	29
22	4×5.8	21	5×5.8	26	5×5.8	28	6.3×5.8	37	6.3×5.8	41	8×6.5	52
33	5×5.8	29	5×5.8	32	6.3×5.8	41	6.3×5.8	45	8×6.5	62	8×10.5	75
47	5×5.8	35	6.3×5.8	44	6.3×5.8	48	8×6.5	66	8×10.5	86	8×10.5	90
100	6.3×5.8	60	8×6.5	79	8×6.5	86	8×10.5	113	10×10.5	145	10×10.5	151
					8×10.5	101						
220	8×10.5	127	8×10.5	137	8×10.5	150	10×10.5	194	10×10.5	216	—	—
					10×10.5	174						
330	8×10.5	156	10×10.5	194	10×10.5	213	—	—	—	—	—	—
470	10×10.5	215	10×10.5	232	10×10.5	254	—	—	—	—	—	—

(Note) Rated ripple current : 105°C, 120Hz.

Chip Type Audio Use Capacitors **GREEN CAP** **SMD** **For audio** **105°C**
1000hours

- Audio grade surface mount product with completely new components using synthetic mica paper for the separator.
- Both quality sense and sound field that could not be realized by the surface mount products are reproducible.

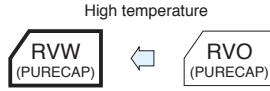

Marking color : Black print (except height : 10mm)
White print on a brown sleeve (φ8×10L, φ10×10L)

Specifications

Item	Performance						
Category temperature range (°C)	-55 to +105						
Tolerance at rated capacitance (%)	±20 (20°C, 120Hz)						
Leakage current (μA)	Less than 0.01CV or 3 whichever is larger (after 2 minutes) C : Rated capacitance (μF) ; V : Rated voltage (V) (20°C)						
Tangent of loss angle (tanδ)	Rated voltage (V)	6.3	10	16	25	35	50
	tanδ (max.)	0.30	0.26	0.22	0.16	0.13	0.12
Characteristics at high and low temperature	Impedance ratio (max.)	Z-25°C/Z+20°C	4	3	2	2	2
		Z-40°C/Z+20°C	8	5	4	3	3
Endurance (105°C) (Applied ripple current)	Test time	1000 hours					
	Leakage current	The initial specified value or less					
	Percentage of capacitance change	Within ±20% of initial value					
	Tangent of the loss angle	200% or less of the initial specified value					
Shelf life (105°C)	Test time : 1000 hours ; other items are the same as those for the endurance. Voltage application treatment						
Applicable standards	JIS C5101-1 1998, -18 1999 (IEC 60384-1 1992, -18 1993)						

Outline Drawing

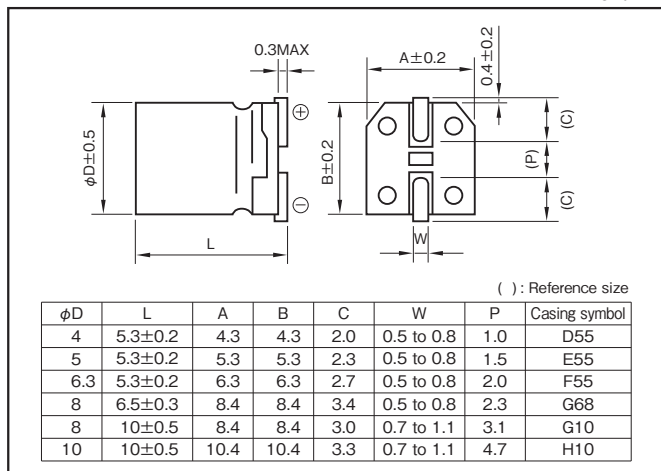

Coefficient of Frequency for Rated Ripple Current

Frequency (Hz)	50	120	1k	10k-100k
Rated voltage (V)				
6.3 to 16	0.80	1	1.15	1.25
25 to 35	0.80	1	1.25	1.40
50	0.80	1	1.35	1.50

Part numbering system (example : 16V471M H10 P2 U)

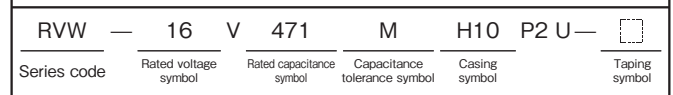

- Soldering conditions are described on page 13.
- Land pattern size are described on page 11.
- The taping specifications are described on page 14.

Standard Ratings

Rated capacitance (μF)	6.3		10		16		25		35		50	
	Case	Rated ripple current	Case	Rated ripple current	Case	Rated ripple current	Case	Rated ripple current	Case	Rated ripple current	Case	Rated ripple current
0.22	—	—	—	—	—	—	—	—	—	—	4×5.3	3
0.33	—	—	—	—	—	—	—	—	—	—	4×5.3	4
0.47	—	—	—	—	—	—	—	—	—	—	4×5.3	5
1	—	—	—	—	—	—	—	—	—	—	4×5.3	7
2.2	—	—	—	—	—	—	—	—	—	—	4×5.3	10
3.3	—	—	—	—	—	—	—	—	—	—	4×5.3	12
4.7	—	—	—	—	—	—	—	—	—	—	5×5.3	17
10	—	—	4×5.3	15	4×5.3	16	4×5.3	21	5×5.3	23	6.3×5.3	26
22	4×5.3	21	5×5.3	25	5×5.3	28	6.3×5.3	36	6.3×5.3	50	8×6.5	110
33	5×5.3	30	5×5.3	31	6.3×5.3	40	6.3×5.3	44	8×6.5	110	8×10	178
47	5×5.3	36	6.3×5.3	43	6.3×5.3	47	8×6.5	110	8×10	178	8×10	178
100	6.3×5.3	61	8×6.5	110	8×10	178	8×10	178	10×10	324	10×10	324
220	8×10	178	8×10	178	10×10	324	10×10	324	10×10	324	—	—
330	8×10	178	10×10	324	10×10	324	—	—	—	—	—	—
470	10×10	324	10×10	324	10×10	324	—	—	—	—	—	—

(Note) Rated ripple current : 105°C, 120Hz.

Chip Type Audio Use Capacitors

GREEN CAP SMD For audio

- New developed Al-Foil and Electrolyte for Audio grade allow lower distortion.
- New range of bright and smooth sound is achieved in SMD area.



Marking color : Black print

Specifications

Item	Performance					
Category temperature range (°C)	-40 to +85					
Tolerance at rated capacitance (%)	±20 (20°C, 120Hz)					
Leakage current (µA)	Less than 0.01CV or 3 whichever is larger (after 2 minutes) C : Rated capacitance (µF) ; V : Rated voltage (V) (20°C)					
Tangent of loss angle (tanδ)	Rated voltage (V)	6.3	10	16	25	35
	tanδ (max.)	0.28	0.24	0.20	0.16	0.14
Characteristics at high and low temperature	Impedance ratio (max.)	Z-25°C/Z+20°C	4	3	2	2
		Z-40°C/Z+20°C	8	5	4	3
Endurance (85°C) (Applied ripple current)	Test time	2000 hours				
	Leakage current	The initial specified value or less				
	Percentage of capacitance change	Within ±20% of initial value				
	Tangent of the loss angle	200% or less of the initial specified value				
Shelf life (85°C)	Test time : 500 hours ; other items are the same as those for the endurance. Voltage application treatment					
Applicable standards	JIS C5101-1 1998, -18 1999 (IEC 60384-1 1992, -18 1993)					

Outline Drawing

Unit : mm

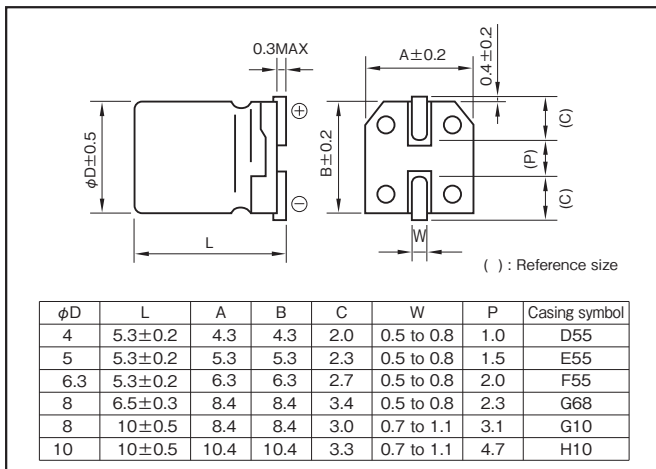

Coefficient of Frequency for Rated Ripple Current

Frequency (Hz)	50	120	1k	10k · 100k
Rated voltage (V)				
6.3 to 16	0.80	1	1.15	1.25
25 to 35	0.80	1	1.25	1.40

Part numbering system (example : 16V47 µF)

RVG	-	16	V	470	M	F55	U	-	□
Series code		Rated voltage symbol		Rated capacitance symbol	Capacitance tolerance symbol	Casing symbol			Taping symbol

- Soldering conditions are described on page 13.
- Land pattern size are described on page 11.
- The taping specifications are described on page 14.

Standard Ratings

Rated voltage (V)	6.3		10		16		25		35	
	Case	Rated ripple current	Case	Rated ripple current	Case	Rated ripple current	Case	Rated ripple current	Case	Rated ripple current
	φD×L (mm)	(mArms)	φD×L (mm)	(mArms)	φD×L (mm)	(mArms)	φD×L (mm)	(mArms)	φD×L (mm)	(mArms)
3.3	—	—	—	—	—	—	—	—	4×5.3	11
4.7	—	—	—	—	4×5.3	11	4×5.3	12	4×5.3	13
10	—	—	—	—	5×5.3	19	5×5.3	21	5×5.3	22
22	4×5.3	20	—	—	5×5.3	28	6.3×5.3	36	6.3×5.3	39
33	5×5.3	29	5×5.3	31	6.3×5.3	40	6.3×5.3	44	8×6.5	60
47	5×5.3	34	6.3×5.3	43	6.3×5.3	47	8×6.5	66	8×10	82
100	6.3×5.3	58	8×6.5	79	8×6.5	87	8×10	112	10×10	139
220	8×6.5	107	8×10	136	8×10	149	10×10	192	—	—
330	8×10	153	8×10	166	10×10	221	—	—	—	—
470	8×10	183	10×10	229	—	—	—	—	—	—

(Note) Rated ripple current : 85°C, 120Hz

NOTE

Design, Specifications are subject to change without notice.
Ask factory for technical specifications before purchase and/or use.

SILMIC series Silk fiber using audio purpose capacitor

- ELNA developed new raw material for the separate paper which use a silk fibers. Therefore, this capacitor can give you high grade sound for your audio design.
- Due to the silk fiber's pliability, the capacitor makes a dream of the high quality sound.

For examples ;

- To relieve the music's vibration energy.
- To decrease the peak feeling sound at high compass and rough quality sound at middle compass.
- To increase massive sound at low compass.
- For bipolar capacitors, consult with us.

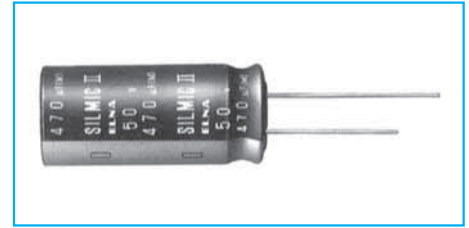

Marking color : White print on a brown sleeve

Miniature High Grade Capacitors for Audio(SILMIC II)

GREEN CAP

For audio

- All lead wires oxygen-free copper for extremely low distortion. (Third high frequency distortion 10kHz,0.1A,-120dB or less)
- "SILMIC II" mark on sleeve.

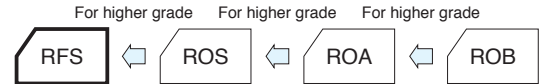

Specifications

Item	Performance								
Category temperature range (°C)	-40 to +85								
Tolerance at rated capacitance (%)	±20 (20°C,120Hz)								
Leakage current (µA)	Less than 0.01CV or 3 whichever is larger (after 5 minutes) C : Rated capacitance (µF) ; V : Rated voltage (V) (20°C)								
Tangent of loss angle (tanδ)	Rated voltage (V)	6.3	10	16	25	35	50	63	100
	tanδ (max.)	0.20	0.17	0.13	0.10	0.10	0.08	0.08	0.08
0.02 is added to every 1000µF increase over 1000µF (20°C,120Hz)									
Endurance (85°C) (Applied ripple current)	Test time	1000 hours (with the polarity inverted every 250 hours)							
	Leakage current	The initial specified value or less							
	Percentage of capacitance change	Within ±20% of initial value							
	Tangent of the loss angle	150% or less of the initial specified value							
Shelf life (85°C)	Test time : 1000 hours. Other have same as endurance. Voltage application treatment								
Applicable standards	JIS C5101-1, -4 1998 (IEC 60384-1 1992, -4 1985)								

Outline Drawing

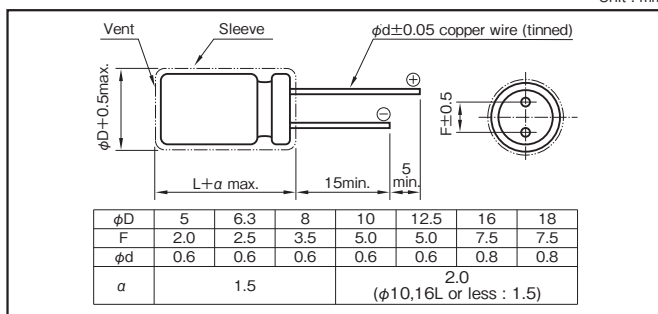

Coefficient of Frequency for Rated Ripple Current

Rated voltage (V)	Frequency (Hz) CV (µF×WV)	50 · 60	120	1k	10k	100k
		6.3 to 16	All CV value	0.8	1	1.1
25 to 35	≤1000	0.8	1	1.5	1.7	1.7
	1000 <	0.8	1	1.2	1.3	1.3
50 to 100	≤1000	0.8	1	1.6	1.9	1.9
	1000 <	0.8	1	1.2	1.3	1.3

Part numbering system (example : 25V100µF)

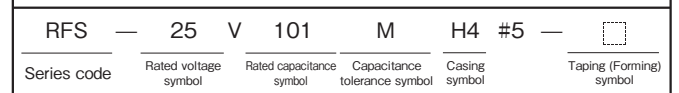

Case symbol

Case φD×L (mm)	Casing Symbol	Case φD×L (mm)	Casing Symbol	Case φD×L (mm)	Casing Symbol	Case φD×L (mm)	Casing Symbol
5×11	E3	10×12.5	H3	12.5×20	I5	16×31.5	J7
6.3×11	F3	10×16	H4	12.5×25	I6	16×35.5	J8
8×11.5	G3	10×20	H5	16×25	J6	18×35.5	K8
				18×40	J9		

Standard Ratings

Rated capacitance (µF)	6.3		10		16		25		35		50		63		100	
	Case φD×L (mm)	Rated ripple current (mA)	Case φD×L (mm)	Rated ripple current (mA)	Case φD×L (mm)	Rated ripple current (mA)	Case φD×L (mm)	Rated ripple current (mA)	Case φD×L (mm)	Rated ripple current (mA)	Case φD×L (mm)	Rated ripple current (mA)	Case φD×L (mm)	Rated ripple current (mA)	Case φD×L (mm)	Rated ripple current (mA)
2.2	—	—	—	—	—	—	—	—	—	—	5×11	20	5×11	22	5×11	25
3.3	—	—	—	—	—	—	—	—	—	—	6.3×11	23	5×11	30	8×11.5	40
	—	—	—	—	—	—	—	—	—	—	6.3×11	30	6.3×11	40	10×12.5	60
4.7	—	—	—	—	—	—	5×11	25	5×11	30	5×11	35	5×11	35	10×12.5	60
	—	—	—	—	—	—	5×11	35	5×11	35	6.3×11	60	6.3×11	40	10×16	95
10	—	—	—	—	5×11	35	6.3×11	60	5×11	60	8×11.5	95	10×12.5	130	10×16	140
	—	—	—	—	6.3×11	70	6.3×11	80	6.3×11	80	10×12.5	140	10×16	175	10×20	190
22	—	—	5×11	50	5×11	55	5×11	60	8×11.5	95	10×12.5	130	10×16	140	12.5×20	220
	—	—	6.3×11	70	6.3×11	90	6.3×11	90	8×11.5	125	10×16	175	10×20	190	12.5×20	220
33	5×11	55	5×11	65	5×11	70	8×11.5	120	10×12.5	140	10×16	175	10×20	190	12.5×20	220
	6.3×11	80	6.3×11	85	6.3×11	90	8×11.5	125	10×12.5	170	10×16	210	10×20	225	12.5×25	285
47	5×11	65	5×11	75	8×11.5	125	8×11.5	140	10×12.5	170	10×16	210	10×20	225	12.5×25	285
100	8×11.5	135	8×11.5	145	10×12.5	215	10×16	270	10×20	295	12.5×20	380	12.5×25	415	16×25	485
220	10×12.5	240	10×16	260	10×20	385	12.5×20	505	12.5×25	550	16×25	720	16×31.5	785	18×40	930
330	10×16	290	10×20	350	12.5×20	545	12.5×25	675	16×25	785	16×31.5	965	16×35.5	1010	—	—
470	10×20	390	12.5×20	455	12.5×25	710	16×25	940	16×31.5	1030	16×35.5	1210	18×35.5	1295	—	—
1000	12.5×20	710	16×25	835	16×31.5	1315	16×35.5	1575	18×35.5	1690	18×40	1985	—	—	—	—
2200	—	—	16×35.5	1500	18×40	2150	—	—	—	—	—	—	—	—	—	—
3300	—	—	18×40	1980	—	—	—	—	—	—	—	—	—	—	—	—

(Note) Rated ripple current : 85°C, 120Hz

NOTE

Design, Specifications are subject to change without notice. Ask factory for technical specifications before purchase and/or use.

SILMIC series Silk fiber using audio purpose capacitor

High Grade Capacitors for Audio(SILMIC)

GREEN CAP For audio

- All lead wires oxygen-free copper for extremely low distortion. (Third high frequency distortion 10kHz,0.1A,-120dB or less)
- "SILMIC" mark on sleeve.



Marking color : White print on a brown sleeve

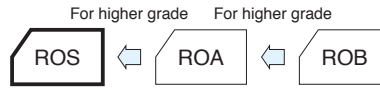

Specifications

Item	Performance						
Category temperature range (°C)	-40 to +85						
Tolerance at rated capacitance (%)	±20 (20°C,120Hz)						
Leakage current (μA)	Less than 0.01CV or 3 whichever is larger (after 5 minutes) C : Rated capacitance (μF) ; V: Rated voltage (V) (20°C)						
Tangent of loss angle (tanδ)	Rated voltage (V)	16	25	35	50	63	100
	tanδ (max.)	0.13	0.10	0.10	0.08	0.08	0.08
0.02 is added to every 1000μF increase over 1000μF (20°C,120Hz)							
Endurance (85°C) (Applied ripple current)	Test time	1000 hours					
	Leakage current	The initial specified value or less					
	Percentage of capacitance change	Within ±20% of initial value					
	Tangent of the loss angle	150% or less of the initial specified value					
Shelf life (85°C)	Test time : 1000 hours. Other have same as endurance. Voltage application treatment						
Applicable standards	JIS C5101-1, -4 1998 (IEC 60384-1 1992, -4 1985)						

Outline Drawing

Unit : mm

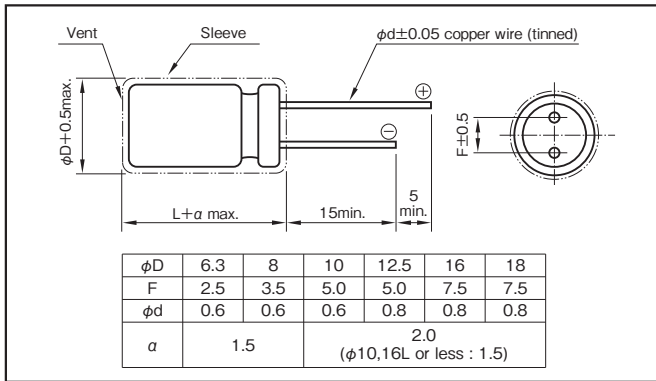

Coefficient of Frequency for Rated Ripple Current

Rated voltage (V)	Frequency (Hz) CV(μF×VV)	50 · 60	120	1k	10k	100k
		16	All CV value	0.80	1	1.1
25 to 35	≤1000	0.80	1	1.5	1.7	1.7
	1000<	0.80	1	1.2	1.3	1.3
50 to 100	≤1000	0.80	1	1.6	1.9	1.9
	1000<	0.80	1	1.2	1.3	1.3

Part numbering system (example : 25V100μF)

ROS	25	V	101	M	H4	#5	—	□
Series code	Rated voltage symbol	Rated capacitance symbol	Capacitance tolerance symbol	Casing symbol	Taping (Forming) symbol			

Case symbol

Case φD×L (mm)	Casing Symbol	Case φD×L (mm)	Casing Symbol	Case φD×L (mm)	Casing Symbol	Case φD×L (mm)	Casing Symbol
5×11	E3	10×12.5	H3	12.5×20	I5	16×31.5	J7
6.3×11	F3	10×16	H4	12.5×25	I6	16×35.5	J8
8×11.5	G3	10×20	H5	16×25	J6	18×35.5	K8
				18×40	K9		

Standard Ratings

Rated voltage (V)	Item	16		25		35		50		63		100	
		Case φD×L (mm)	Rated ripple current (mA _{rms})	Case φD×L (mm)	Rated ripple current (mA _{rms})	Case φD×L (mm)	Rated ripple current (mA _{rms})	Case φD×L (mm)	Rated ripple current (mA _{rms})	Case φD×L (mm)	Rated ripple current (mA _{rms})	Case φD×L (mm)	Rated ripple current (mA _{rms})
2.2	—	—	—	—	—	—	—	—	—	—	—	6.3×11	25
3.3	—	—	—	—	—	—	—	—	—	—	—	8×11.5	35
4.7	—	—	—	—	—	—	—	6.3×11	40	6.3×11	40	10×12.5	60
10	—	—	—	—	—	6.3×11	55	8×11.5	75	8×11.5	75	10×16	95
22	6.3×11	70	6.3×11	80	8×11.5	95	10×12.5	130	10×16	140	10×20	155	
33	6.3×11	90	8×11.5	120	10×12.5	140	10×16	175	10×20	190	12.5×20	220	
47	8×11.5	125	8×11.5	140	10×12.5	170	10×16	210	10×20	225	12.5×25	285	
100	10×12.5	215	10×16	270	10×20	295	12.5×20	380	12.5×25	415	16×25	485	
220	10×20	385	12.5×20	505	12.5×25	550	16×25	720	16×31.5	785	18×40	930	
330	12.5×20	545	12.5×25	675	16×25	785	16×31.5	965	16×35.5	1010	—	—	
470	12.5×25	710	16×25	940	16×31.5	1030	16×35.5	1210	18×35.5	1295	—	—	
1000	16×31.5	1315	16×35.5	1575	18×35.5	1690	18×40	1985	—	—	—	—	
2200	18×40	2150	—	—	—	—	—	—	—	—	—	—	

(Note) Rated ripple current : 85°C, 120Hz.

NOTE

Design, Specifications are subject to change without notice. Ask factory for technical specifications before purchase and/or use.

Miniature Standard Capacitors for Audio

GREEN CAP For audio

TONEREX

- Adopting the newly developed formation method and composite electrolytic paper for audio application has reduced distortion, achieving high-quality sound.
- All lead wires are oxygen-free copper wires to reduce distortion.



Marking color : Gold print on a black sleeve

Specifications

Item	Performance								
Category temperature range (°C)	-40 to +85								
Tolerance at rated capacitance (%)	±20 (20°C,120Hz)								
Leakage current (μA)	Less than 0.01CV or 4 whichever is larger (after 5 minutes) C : Rated capacitance (μF) ; V : Rated voltage (V) (20°C)								
Tangent of loss angle (tanδ)	Rated voltage (V)	6.3	10	16	25	35	50	63	100
	tanδ (max.)	0.24	0.20	0.16	0.14	0.12	0.10	0.09	0.08
0.02 is added to every 1000μF increase over 1000μF (20°C,120Hz)									
Endurance (85°C) (Applied ripple current)	Test time	1000 hours							
	Leakage current	The initial specified value or less							
	Percentage of capacitance change	Within ±20% of initial value							
	Tangent of the loss angle	150% or less of the initial specified value							
Shelf life (85°C)	Test time : 1000 hours. Other have same as endurance. Voltage application treatment								
Applicable standards	JIS C5101-1, -4 1998 (IEC 60384-1 1992, -4 1985)								

Outline Drawing

Unit : mm

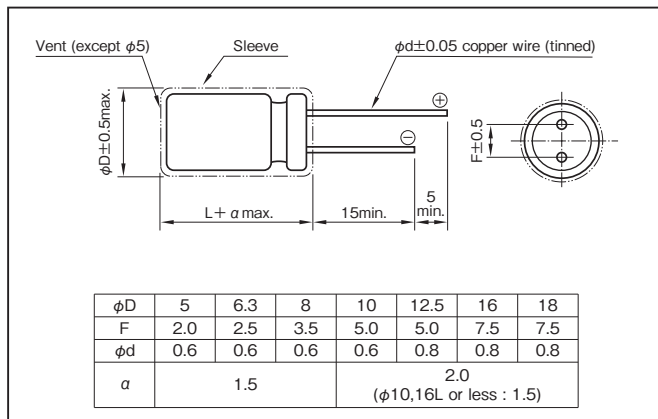

Coefficient of Frequency for Rated Ripple Current

Rated voltage (V)	Frequency (Hz) CV (μF×VV)	50·60	120	1k	10k	100k
		6.3 to 16	All CV value	0.80	1	1.1
25 to 35	≤1000	0.80	1	1.5	1.7	1.7
	1000<	0.80	1	1.2	1.3	1.3
50 to 100	≤1000	0.80	1	1.6	1.9	1.9
	1000<	0.80	1	1.2	1.3	1.3

Part numbering system (example : 25V100μF)

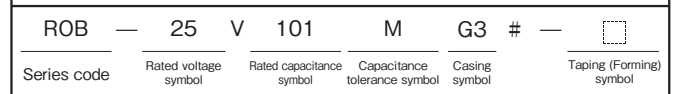

Case symbol

Case φD×L (mm)	Casing Symbol	Case φD×L (mm)	Casing Symbol	Case φD×L (mm)	Casing Symbol	Case φD×L (mm)	Casing Symbol
5×11	E3	10×12.5	H3	12.5×20	I5	16×31.5	J7
6.3×11	F3	10×16	H4	12.5×25	I6	16×35.5	J8
8×11.5	G3	10×20	H5	16×25	J6	18×35.5	K8
						18×40	K9

Standard Ratings

Rated capacitance (μF)	Item	6.3		10		16		25		35		50		63		100	
		Case φD×L (mm)	Rated ripple current (mA _{rms})	Case φD×L (mm)	Rated ripple current (mA _{rms})	Case φD×L (mm)	Rated ripple current (mA _{rms})	Case φD×L (mm)	Rated ripple current (mA _{rms})	Case φD×L (mm)	Rated ripple current (mA _{rms})	Case φD×L (mm)	Rated ripple current (mA _{rms})	Case φD×L (mm)	Rated ripple current (mA _{rms})	Case φD×L (mm)	Rated ripple current (mA _{rms})
1		—	—	—	—	—	—	—	—	—	—	5×11	10	—	—	5×11	15
2.2		—	—	—	—	—	—	—	—	—	—	5×11	20	—	—	5×11	25
3.3		—	—	—	—	—	—	—	—	—	—	5×11	25	—	—	5×11	30
4.7		—	—	—	—	—	—	5×11	25	—	—	5×11	35	5×11	35	6.3×11	40
10		—	—	—	—	5×11	35	5×11	40	5×11	45	5×11	50	6.3×11	60	8×11.5	70
22		—	—	5×11	50	5×11	60	5×11	60	6.3×11	75	6.3×11	80	8×11.5	100	10×12.5	120
33		5×11	55	5×11	65	5×11	70	6.3×11	80	6.3×11	90	8×11.5	110	8×11.5	115	10×16	160
47		5×11	65	5×11	75	6.3×11	95	6.3×11	100	8×11.5	120	8×11.5	130	10×12.5	165	10×20	210
100		6.3×11	110	6.3×11	120	8×11.5	150	8×11.5	165	10×12.5	210	10×16	250	10×20	285	12.5×20	340
220		8×11.5	185	8×11.5	200	10×12.5	265	10×16	310	10×20	365	12.5×20	440	12.5×20	470	16×25	620
330		10×12.5	265	10×12.5	200	10×16	350	10×20	410	12.5×20	500	12.5×20	540	12.5×25	620	16×31.5	820
470		10×12.5	315	10×16	380	10×20	460	12.5×20	550	12.5×25	640	16×25	800	16×25	840	18×35.5	1000
1000		10×20	550	12.5×20	670	12.5×25	810	16×25	1000	16×25	1050	16×31.5	1200	18×35.5	1500	—	—
2200		12.5×25	980	16×25	1200	16×25	1350	16×35.5	1650	18×35.5	1900	—	—	—	—	—	—
3300		16×25	1300	16×31.5	1600	16×35.5	1800	18×40	2100	—	—	—	—	—	—	—	—
4700		16×31.5	1700	16×35.5	1900	18×35.5	2400	—	—	—	—	—	—	—	—	—	—
6800		16×35.5	2100	18×40	2600	—	—	—	—	—	—	—	—	—	—	—	—
10000		18×40	2800	—	—	—	—	—	—	—	—	—	—	—	—	—	—

(Note) Rated ripple current : 85°C, 120Hz

NOTE

Design, Specifications are subject to change without notice.
Ask factory for technical specifications before purchase and/or use.

For Audio, Ultra Miniaturized (PURECAP)

GREEN CAP

For audio

- A new foil and electrolyte makes powerful and clear sound.
- New type ultra miniaturized capacitor for audio, using synthetic mica paper for the separator.

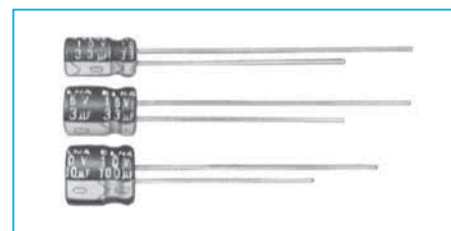

Marking color : White print on a black sleeve



Specifications

Item	Performance	
Category temperature range (°C)	-40 to +85	
Tolerance at rated capacitance (%)	±20 (20°C, 120Hz)	
Leakage current (μA)	Less than 0.01CV or 3 whichever is larger (after 2 minutes) C : Rated capacitance (μF) ; V : Rated voltage (V) (20°C)	
Tangent of loss angle (tanδ)	Rated voltage (V)	6.3 10 16 25 35 50
	tanδ (max.)	0.35 0.27 0.22 0.20 0.17 0.15
Characteristics at high and low temperature	Rated voltage (V)	6.3 10 16 25 35 50
	Impedance ratio (max.)	Z-25°C/Z+20°C: 4 3 2 2 2 2 Z-40°C/Z+20°C: 10 8 6 4 4 4
Endurance (85°C) (Applied ripple current)	Test time	1000 hours
	Leakage current	The initial specified value or less
	Percentage of capacitance change	Within ±20% of initial value
	Tangent of the loss angle	200% or less of the initial specified value
Shelf life (85°C)	Test time : 500 hours; other items are the same as those for the endurance. Voltage application treatment	
Applicable standards	JIS C5101-1, -4 1998 (IEC 60384-1 1992, -4 1985)	

Outline Drawing

Unit : mm

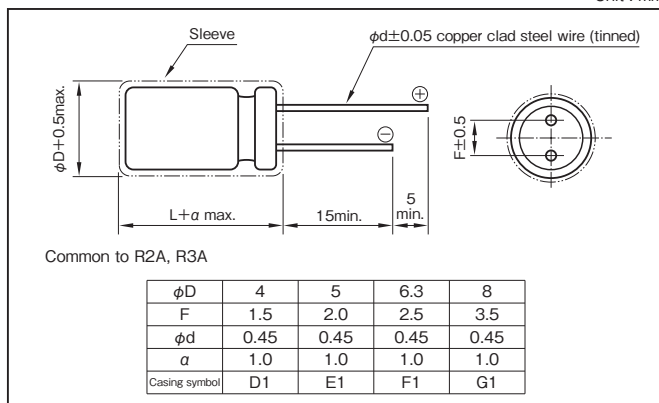

Part numbering system (example : 25V10μF)					
R2A	—	25	V	100	M D1 P6#
Series code		Rated voltage symbol		Rated capacitance symbol	Capacitance tolerance symbol
				Casing symbol	Taping (Forming) symbol

Standard Ratings

φD×L (mm)

Rated voltage (V)	6.3	10	16	25	35	50
0.33	—	—	—	—	—	4×7
0.47	—	—	—	—	—	4×7
1	—	—	—	—	—	4×7
2.2	—	—	—	—	—	4×7
3.3	—	—	—	—	—	4×7
4.7	—	—	—	—	4×7	5×7
10	—	—	—	4×7	5×7	6.3×7
22	—	4×7	—	5×7	—	6.3×7
33	4×7	—	5×7	6.3×7	6.3×7	8×7
47	—	5×7	—	6.3×7	8×7	—
100	5×7	6.3×7	6.3×7	8×7	—	—
220	6.3×7	8×7	—	—	—	—
330	8×7	—	—	—	—	—

(Note) "→" items are refer to the right.

NOTE

Design, Specifications are subject to change without notice. Ask factory for technical specifications before purchase and/or use.

For Audio, Ultra Miniaturized (PURECAP)

GREEN CAP For audio

- A new foil and electrolyte makes powerful and clear sound.
- New type ultra miniaturized capacitor for audio, using synthetic mica paper for the separator.

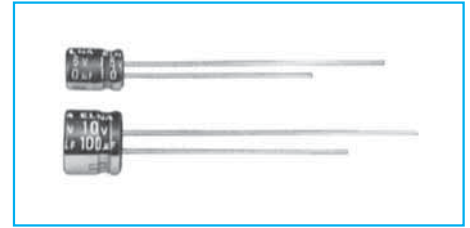

Marking color : White print on a reddish purple sleeve

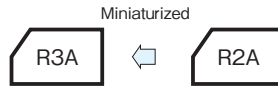

Specifications

Item	Performance								
Category temperature range (°C)	-40 to +85								
Tolerance at rated capacitance (%)	±20 (20°C, 120Hz)								
Leakage current (µA)	Less than 0.01CV or 3 whichever is larger (after 2 minutes) C : Rated capacitance (µF) ; V : Rated voltage (V) (20°C)								
Tangent of loss angle (tanδ)	Rated voltage (V)	4	6.3	10	16	25	35	50	
	tanδ (max.)	0.46	0.30	0.26	0.20	0.17	0.13	0.11	
(20°C, 120Hz)									
Characteristics at high and low temperature	Rated voltage (V)	4	6.3	10	16	25	35	50	
	Impedance ratio (max.)	Z-25°C/Z+20°C	6	4	3	2	2	2	2
		Z-40°C/Z+20°C	16	10	8	6	4	4	4
(120Hz)									
Endurance (85°C) (Applied ripple current)	Test time	1000 hours							
	Leakage current	The initial specified value or less							
	Percentage of capacitance change	Within ±20% of initial value							
	Tangent of the loss angle	200% or less of the initial specified value							
Shelf life (85°C)	Test time : 500hours ; other items are the same as those for the endurance. Voltage application treatment								
Applicable standards	JIS C5101-1, -4 1998 (IEC 60384-1 1992, -4 1985)								

Outline Drawing

Unit : mm

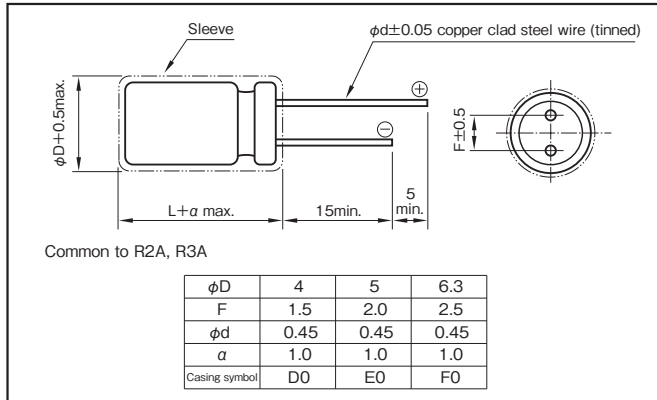

Part numbering system (example : 35V10µF)

R3A	—	35	V	101	M	E0	P3#	—	□
Series code		Rated voltage symbol		Rated capacitance symbol	Capacitance tolerance symbol	Casing symbol			Taping (Forming) symbol

Standard Ratings

φD×L (mm)

Rated voltage (V) / Rated capacitance (µF)	4	6.3	10	16	25	35	50
0.22	—	—	—	—	—	—	4×5
0.33	—	—	—	—	—	—	4×5
0.47	—	—	—	—	—	—	4×5
1	—	—	—	—	—	—	4×5
2.2	—	—	—	—	—	—	4×5
3.3	—	—	—	—	—	—	4×5
4.7	—	—	—	—	→	4×5	5×5
10	—	—	→	4×5	→	5×5	6.3×5
22	—	4×5	→	5×5	→	6.3×5	—
33	4×5	→	5×5	→	6.3×5	—	—
47	4×5	5×5	→	6.3×5	—	—	—
100	5×5	→	6.3×5	—	—	—	—
220	6.3×5	—	—	—	—	—	—

(Note) "→" items are refer to the right.

NOTE

Design, Specifications are subject to change without notice. Ask factory for technical specifications before purchase and/or use.

Miniature Capacitors for Audio

GREEN CAP For audio

- A standard capacitor utilizing a newly developed material for a high grade of audio reproduction.
- Copper clad steel wire is used for leads.
- New type miniaturized capacitor for audio, using synthetic mica paper for the separator.

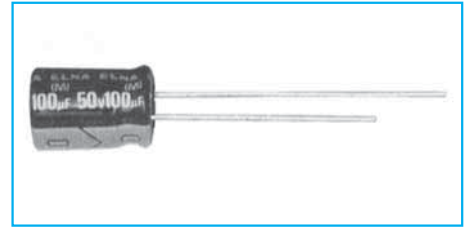

Marking color : Gold print on a black sleeve

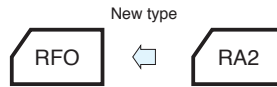

Specifications

Item	Performance								
Category temperature range (°C)	-40 to +85								
Tolerance at rated capacitance (%)	±20 (20°C, 120Hz)								
Leakage current (µA)	Less than 0.01CV or 3 whichever is larger (after 2 minutes) C : Rated capacitance (µF) ; V : Rated voltage (V) (20°C)								
Tangent of loss angle (tanδ)	Rated voltage (V)	6.3	10	16	25	35	50	63	100
	tanδ (max.)	0.22	0.19	0.16	0.14	0.12	0.10	0.09	0.08
0.02 is added to every 1000µF increase over 1000µF (20°C, 120Hz)									
Endurance (85°C) (Applied ripple current)	Test time	1000 hours							
	Leakage current	The initial specified value or less							
	Percentage of capacitance change	Within ±20% of initial value							
	Tangent of the loss angle	150% or less of the initial specified value							
Shelf life (85°C)	Test time : 1000 hours. Other have same as endurance. Voltage application treatment								
Applicable standards	JIS C5101-1, -4 1998 (IEC 60384-1 1992, -4 1985)								

Outline Drawing

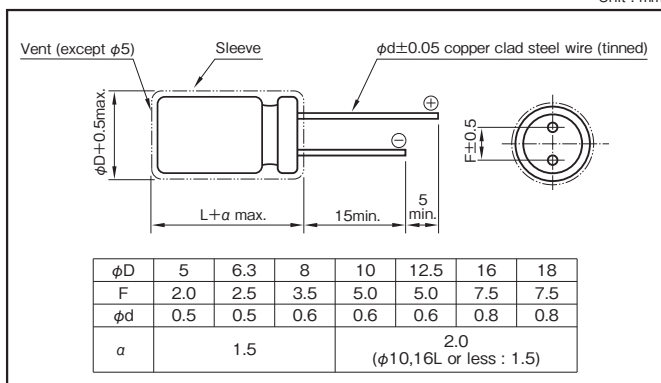

Coefficient of Frequency for Rated Ripple Current

Rated voltage(V)	Frequency(Hz) CV(µF×VV)	50 · 60	120	1k	10k	100k
		6.3 to 16	All CV value	0.80	1	1.1
25 to 35	≤1000	0.80	1	1.5	1.7	1.7
	1000<	0.80	1	1.2	1.3	1.3
50 to 100	≤1000	0.80	1	1.6	1.9	1.9
	1000<	0.80	1	1.2	1.3	1.3

Part numbering system (example : 25V100µF)

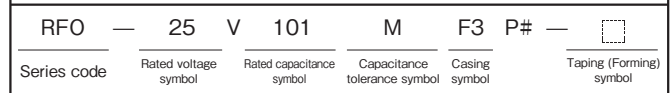

Case symbol

Case φD×L (mm)	Casing Symbol	Case φD×L (mm)	Casing Symbol	Case φD×L (mm)	Casing Symbol	Case φD×L (mm)	Casing Symbol
5×11	E3	10×12.5	H3	12.5×20	I5	16×31.5	J7
6.3×11	F3	10×16	H4	12.5×25	I6	16×35.5	J8
8×11.5	G3	10×20	H5	16×25	J6	18×35.5	K8
				18×40			K9

Standard Ratings

Rated capacitance (µF)	6.3		10		16		25		35		50		63		100		
	Case φD×L (mm)	Rated ripple current (mArms)	Case φD×L (mm)	Rated ripple current (mArms)	Case φD×L (mm)	Rated ripple current (mArms)	Case φD×L (mm)	Rated ripple current (mArms)	Case φD×L (mm)	Rated ripple current (mArms)	Case φD×L (mm)	Rated ripple current (mArms)	Case φD×L (mm)	Rated ripple current (mArms)	Case φD×L (mm)	Rated ripple current (mArms)	
1	—	—	—	—	—	—	—	—	—	—	5×11	15	—	—	5×11	15	
2.2	—	—	—	—	—	—	—	—	—	—	5×11	20	—	—	5×11	25	
3.3	—	—	—	—	—	—	—	—	—	—	5×11	25	—	—	5×11	30	
4.7	—	—	—	—	—	—	—	—	—	5×11	30	5×11	30	5×11	35	5×11	35
10	—	—	—	—	—	—	—	—	—	5×11	45	5×11	45	5×11	50	6.3×11	60
22	—	—	—	—	5×11	50	5×11	55	5×11	60	5×11	70	6.3×11	85	8×11.5	110	
33	—	—	5×11	55	5×11	60	5×11	70	5×11	80	6.3×11	100	6.3×11	100	10×12.5	160	
47	—	—	5×11	65	5×11	75	5×11	85	6.3×11	110	6.3×11	120	8×11.5	150	10×16	210	
100	5×11	85	5×11	95	6.3×11	120	6.3×11	140	8×11.5	190	8×11.5	210	10×12.5	260	12.5×20	380	
220	6.3×11	150	6.3×11	165	8×11.5	220	8×11.5	250	10×12.5	330	10×16	400	10×20	460	16×25	720	
330	6.3×11	180	8×11.5	240	8×11.5	270	10×12.5	370	10×16	450	10×20	540	12.5×20	650	16×25	880	
470	8×11.5	260	8×11.5	280	10×12.5	390	10×16	480	10×20	590	12.5×20	740	12.5×25	850	16×31.5	1150	
1000	10×12.5	450	10×16	540	10×20	680	12.5×20	880	12.5×25	1050	16×25	1350	16×31.5	1550	—	—	
2200	12.5×20	890	12.5×20	970	12.5×25	1200	16×25	1550	16×31.5	1750	16×35.5	2100	—	—	—	—	
3300	12.5×20	1050	12.5×25	1250	16×25	1600	16×31.5	1950	18×35.5	2250	—	—	—	—	—	—	
4700	16×25	1550	16×25	1650	16×31.5	2050	18×35.5	2500	—	—	—	—	—	—	—	—	
6800	16×25	1750	16×31.5	2050	18×35.5	2550	—	—	—	—	—	—	—	—	—	—	
10000	16×31.5	2150	18×35.5	2550	—	—	—	—	—	—	—	—	—	—	—	—	
15000	18×35.5	2700	—	—	—	—	—	—	—	—	—	—	—	—	—	—	

(Note) Rated ripple current : 85°C, 120Hz

Miniature Capacitors for Audio GREEN CAP For audio

- With the same size as that for Series RE3 miniaturized standard capacitors, a high resolution sound quality grade has been realized.
- The newly developed audio use material makes clear sound a reality.
- All lead wires are copper clad steel.

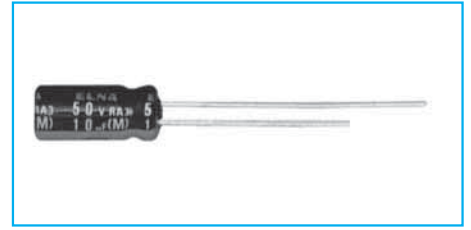
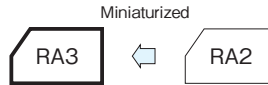

Marking color : White print on a brown sleeve

Specifications

Item	Performance									
Category temperature range (°C)	-40 to +85									
Tolerance at rated capacitance (%)	±20 (20°C,120Hz)									
Leakage current (µA)	Less than 0.01CV or 3 whichever is larger (after 2 minutes) C : Rated capacitance (µF) ; V : Rated voltage (V) (20°C)									
Tangent of loss angle (tanδ)	Rated voltage (V)	6.3	10	16	25	35	50	63	100	
	tanδ (max.)	0.28	0.24	0.20	0.16	0.14	0.12	0.11	0.10	
0.02 is added to every 1000µF increase over 1000µF (20°C,120Hz)										
Endurance (85°C) (Applied ripple current)	Test time	2000 hours								
	Leakage current	The initial specified value or less								
	Percentage of capacitance change	Within ±20% of initial value								
	Tangent of the loss angle	200% or less of the initial specified value								
Shelf life (85°C)	Test time : 1000 hours. Other have same as endurance. Voltage application treatment									
Applicable standards	JIS C5101-1, -4 1998 (IEC 60384-1 1992, -4 1985)									

Outline Drawing

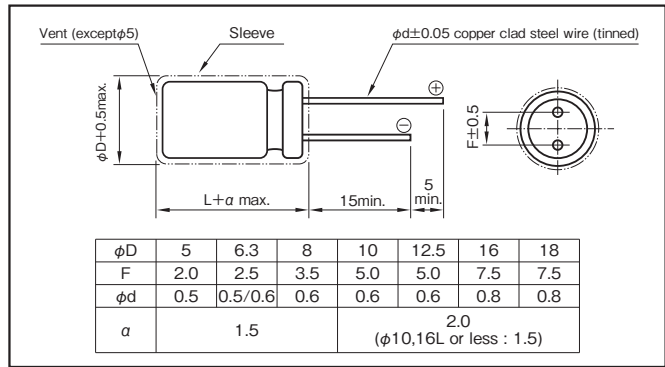

Coefficient of Frequency for Rated Ripple Current

Rated voltage(V)	Frequency (Hz) CV (µF×VV)	50 · 60	120	1k	10k	100k
		6.3 to 16	All CV value	0.80	1	1.1
25 to 35	≤ 1000	0.80	1	1.5	1.7	1.7
	1000<	0.80	1	1.2	1.3	1.3
50 to 100	≤ 1000	0.80	1	1.6	1.9	1.9
	1000<	0.80	1	1.2	1.3	1.3

Part numbering system (example : 25V100µF)

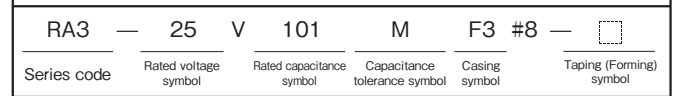

Case symbol

Case φD×L (mm)	Casing Symbol	Case φD×L (mm)	Casing Symbol	Case φD×L (mm)	Casing Symbol	Case φD×L (mm)	Casing Symbol
5×11	E3	10×12.5	H3	12.5×20	I5	16×31.5	J7
6.3×11	F3	10×16	H4	12.5×25	I6	18×35.5	K8
8×11.5	G3	10×20	H5	16×25	J6	—	—

Standard Ratings

Rated capacitance (µF)	6.3		10		16		25		35		50		63		100	
	Case	Rated ripple current	Case	Rated ripple current	Case	Rated ripple current	Case	Rated ripple current	Case	Rated ripple current	Case	Rated ripple current	Case	Rated ripple current	Case	Rated ripple current
	φD×L (mm)	(mAmps)	φD×L (mm)	(mAmps)	φD×L (mm)	(mAmps)	φD×L (mm)	(mAmps)	φD×L (mm)	(mAmps)	φD×L (mm)	(mAmps)	φD×L (mm)	(mAmps)	φD×L (mm)	(mAmps)
1	—	—	—	—	—	—	—	—	—	—	5×11	21	—	—	5×11	21
2.2	—	—	—	—	—	—	—	—	—	—	5×11	31	—	—	5×11	31
3.3	—	—	—	—	—	—	—	—	—	—	5×11	38	—	—	5×11	40
4.7	—	—	—	—	—	—	—	—	—	—	5×11	45	—	—	5×11	50
10	—	—	—	—	5×11	50	5×11	55	5×11	60	5×11	66	5×11	70	5×11	70
22	—	—	—	—	5×11	75	5×11	90	5×11	95	5×11	100	5×11	105	6.3×11	115
33	—	—	—	—	5×11	110	5×11	110	5×11	110	5×11	110	6.3×11	130	8×11.5	158
47	—	—	—	—	5×11	130	5×11	130	5×11	130	6.3×11	155	6.3×11	160	8×11.5	188
100	5×11	130	5×11	150	5×11	180	6.3×11	199	6.3×11	214	8×11.5	250	8×11.5	270	10×16	358
220	5×11	240	6.3×11	250	6.3×11	280	8×11.5	349	8×11.5	350	10×12.5	429	10×16	505	12.5×20	663
330	6.3×11	300	6.3×11	330	8×11.5	383	8×11.5	383	10×12.5	542	10×16	595	10×20	676	12.5×25	886
470	6.3×11	380	8×11.5	417	8×11.5	480	10×12.5	545	10×16	664	12.5×20	887	12.5×20	924	16×25	1230
1000	8×11.5	580	10×12.5	650	10×16	791	10×20	996	12.5×20	1210	12.5×25	1400	16×25	1710	18×35.5	2210
2200	10×16	939	10×20	1080	12.5×20	1350	12.5×25	1660	16×25	1950	16×31.5	2340	18×35.5	2870	—	—
3300	16×20	1230	12.5×20	1430	12.5×25	1690	16×25	2030	16×31.5	2320	18×35.5	2810	—	—	—	—
4700	12.5×20	1710	12.5×25	1780	16×25	2100	16×31.5	2650	18×35.5	2290	—	—	—	—	—	—
6800	12.5×25	1930	16×25	2270	16×31.5	2480	18×35.5	3290	—	—	—	—	—	—	—	—
10000	16×25	2450	16×31.5	2500	18×35.5	3130	—	—	—	—	—	—	—	—	—	—
15000	16×31.5	2580	18×35.5	3100	—	—	—	—	—	—	—	—	—	—	—	—
22000	18×35.5	3150	—	—	—	—	—	—	—	—	—	—	—	—	—	—

(Note) Rated ripple current : 85°C, 120Hz

NOTE

Design, Specifications are subject to change without notice.
Ask factory for technical specifications before purchase and/or use.

For Audio, 105°C Miniature Capacitors

GREEN CAP 105°C 1000hours For Audio

- With the same size as that for Series RJ5 miniaturized standard capacitors, a high resolution sound quality grade has been realized.
- Guarantees 1000 hours at 105°C

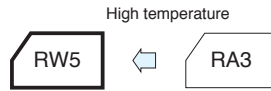

Marking color : Gold print on a black sleeve

Specifications

Item	Performance														
Category temperature range (°C)	-55 to +105														
Tolerance at rated capacitance (%)	±20 (20°C, 120Hz)														
Leakage current (µA)	Less than 0.03CV or 4 whichever is larger (after 1 minutes) C : Rated capacitance (µF) , V : Rated voltage (V) (20°C)														
Tangent of loss angle (tanδ)	<table border="1"> <tr> <td>Rated voltage (V)</td> <td>16</td> <td>25</td> </tr> <tr> <td>tanδ (max.)</td> <td>0.24</td> <td>0.20</td> </tr> </table> 0.02CV is added to every 1000µF increase over 1000µF (20°C, 120Hz)	Rated voltage (V)	16	25	tanδ (max.)	0.24	0.20								
Rated voltage (V)	16	25													
tanδ (max.)	0.24	0.20													
Characteristics at high and low temperature	<table border="1"> <tr> <td>Rated voltage (V)</td> <td>16</td> <td>25</td> </tr> <tr> <td rowspan="2">Impedance ratio (max.)</td> <td>Z-25°C/Z+20°C</td> <td>3</td> </tr> <tr> <td>Z-40°C/Z+20°C</td> <td>6</td> </tr> <tr> <td></td> <td></td> <td>2</td> </tr> <tr> <td></td> <td></td> <td>4</td> </tr> </table> (120Hz)	Rated voltage (V)	16	25	Impedance ratio (max.)	Z-25°C/Z+20°C	3	Z-40°C/Z+20°C	6			2			4
Rated voltage (V)	16	25													
Impedance ratio (max.)	Z-25°C/Z+20°C	3													
	Z-40°C/Z+20°C	6													
		2													
		4													
Endurance (105°C) (Applied ripple current)	<table border="1"> <tr> <td>Test time</td> <td>1000 hours</td> </tr> <tr> <td>Leakage current</td> <td>The initial specified value or less</td> </tr> <tr> <td>Percentage of capacitance change</td> <td>Within ±20% of initial value</td> </tr> <tr> <td>Tangent of the loss angle</td> <td>200% or less of the initial specified value</td> </tr> </table>	Test time	1000 hours	Leakage current	The initial specified value or less	Percentage of capacitance change	Within ±20% of initial value	Tangent of the loss angle	200% or less of the initial specified value						
Test time	1000 hours														
Leakage current	The initial specified value or less														
Percentage of capacitance change	Within ±20% of initial value														
Tangent of the loss angle	200% or less of the initial specified value														
Shelf life (105°C)	Test time : 1000 hours; Other have same as endurance. Voltage application treatment														
Applicable standards	JIS C5101-1, -4 1998 (IEC 60384-1 1992, -4 1985)														

Outline Drawing

Unit : mm

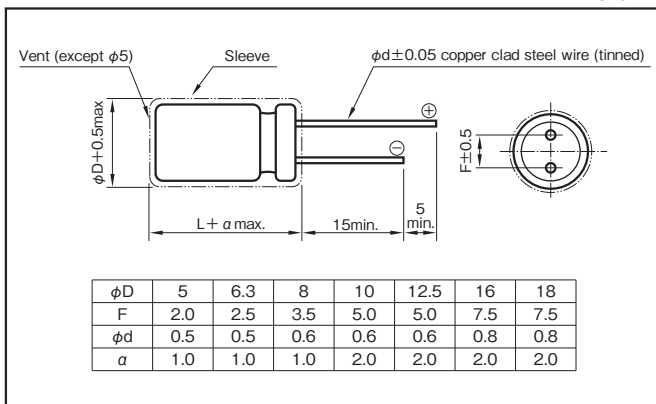

Coefficient of Frequency for Rated Ripple Current

Rated Capacitance (µF)	Frequency (Hz)				
	50 · 60	120	1k	10k	100k
100 to 220	0.8	1	1.2	1.3	1.4
330 to 1000	0.8	1	1.2	1.2	1.3
1200 to 15000	0.8	1	1.1	1.1	1.1

Part numbering system (example : 16V3300µF)

RW5	—	16	V	332	M	I6	#	—	
Series code		Rated voltage symbol		Rated capacitance symbol	Capacitance tolerance symbol	Casing symbol			Taping (Forming) symbol

Standard Ratings

Rated capacitance (µF)	16			25		
	Case φD×L (mm)	Casing symbol	Rated ripple current (mArms)	Case φD×L (mm)	Casing symbol	Rated ripple current (mArms)
100	—	—	—	5×11.5	E3	125
220	6.3×11.5	F3	190	6.3×11.5	F3	200
330	6.3×11.5	F3	225	8×12	G3	310
470	8×12	G3	323	10×12.5	H3	429
1000	10×12.5	H3	500	10×16	H4	610
2200	10×20	H5	710	12.5×25	I6	1180
				16×20	J5	1230
				18×16	K4	1200
3300	12.5×25	I6	1200	16×25	J6	1440
				16×20	J5	1250
4700	16×20	K5	1460	18×20	K5	1400
				16×25	J6	1500
6800	18×20	K5	1560	18×20	K5	1530
				16×25	J6	1600
10000	18×35.5	J8	1930	16×35.5	J8	1850
				18×20	K5	1560
15000	18×40	K9	2210	18×40	K9	2000

(Note) Rated ripple current : 105°C, 120Hz.

NOTE

Design, Specifications are subject to change without notice. Ask factory for technical specifications before purchase and/or use.

Miniature Bipolar Capacitors for Audio

GREEN CAP For audio

- The newly developed audio use foil and special electrolyte makes clear and far-carrying sound a reality.
- All lead wires are copper clad steel.

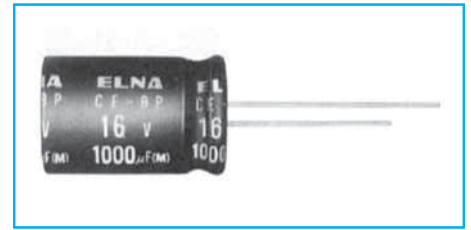

Marking color : Gold print on a black sleeve

Specifications

Item	Performance									
Category temperature range (°C)	-40 to +85									
Tolerance at rated capacitance (%)	±20 (20°C,120Hz)									
Leakage current (µA)	Less than 0.01CV or 4 whichever is larger (after 2 minutes) C : Rated capacitance (µF); V : Rated voltage (V) (20°C)									
Tangent of loss angle (tanδ)	Rated voltage (V)	6.3	10	16	25	35	50	63	100	
	tanδ (max.)	0.24	0.20	0.16	0.15	0.14	0.12	0.10	0.09	0.02 is added to every 1000µF increase over 1000µF. (20°C,120Hz)
Characteristics at high and low temperature	Rated voltage (V)	6.3	10	16	25	35	50	63	100	
	Impedance ratio (max.)	Z-25°C/Z+20°C	4	3	2	2	2	2	2	2
Endurance (85°C) (Applied ripple current)	Test time	250h × 8								
	Leakage current	The initial specified value or less								
	Percentage of capacitance change	Within ±20% of initial value								
	Tangent of the loss angle	150% or less of the initial specified value								
Applicable standards	JIS C5101-1, -4 1998 (IEC 60384-1 1992, -4 1985)									

Outline Drawing

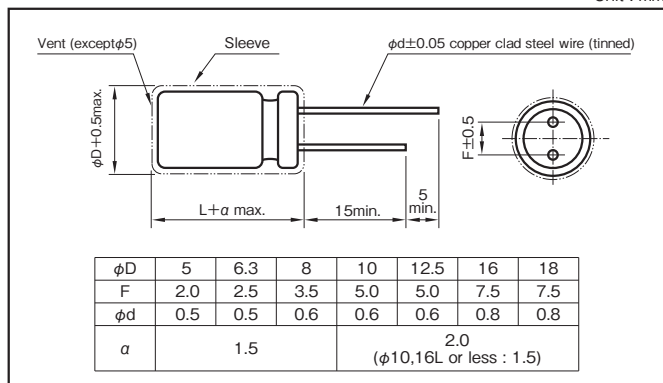

Coefficient of Frequency for Rated Ripple Current

Frequency (Hz)	50 · 60	120	1k	10k · 100k
Rated voltage (V)				
6.3 to 16	0.8	1	1.1	1.2
25 to 35	0.8	1	1.5	1.7
50 to 100	0.8	1	1.6	1.9

Part numbering system (example : 10V1000µF)



Case symbol

Case φD×L (mm)	Casing Symbol	Case φD×L (mm)	Casing Symbol	Case φD×L (mm)	Casing Symbol	Case φD×L (mm)	Casing Symbol
5×11	E3	10×12.5	H3	12.5×20	I5	16×31.5	J7
6.3×11	F3	10×16	H4	12.5×25	I6	16×35.5	J8
8×11.5	G3	10×20	H5	16×25	J6	18×35.5	K8
				18×40			K9

Standard Ratings

Rated capacitance (µF)	6.3		10		16		25		35		50		63		100	
	Case φD×L (mm)	Rated ripple current (mA _{rms})	Case φD×L (mm)	Rated ripple current (mA _{rms})	Case φD×L (mm)	Rated ripple current (mA _{rms})	Case φD×L (mm)	Rated ripple current (mA _{rms})	Case φD×L (mm)	Rated ripple current (mA _{rms})	Case φD×L (mm)	Rated ripple current (mA _{rms})	Case φD×L (mm)	Rated ripple current (mA _{rms})	Case φD×L (mm)	Rated ripple current (mA _{rms})
0.47	—	—	—	—	—	—	—	—	—	—	5×11	10	—	—	5×11	11
1	—	—	—	—	—	—	—	—	—	—	5×11	14	—	—	5×11	16
2.2	—	—	—	—	—	—	—	—	—	—	5×11	21	5×11	23	5×11	24
3.3	—	—	—	—	—	—	—	—	—	—	5×11	26	5×11	28	6.3×11	34
4.7	—	—	—	—	—	—	5×11	28	5×11	28	5×11	31	5×11	34	6.3×11	41
10	—	—	—	—	5×11	39	5×11	40	5×11	42	5×11	45	6.3×11	57	8×11.5	70
22	—	—	5×11	52	5×11	58	5×11	60	6.3×11	71	6.3×11	77	8×11.5	89	10×16	136
33	5×11	58	5×11	63	5×11	71	6.3×11	84	6.3×11	87	8×11.5	111	10×12.5	144	10×20	181
47	5×11	69	5×11	75	6.3×11	97	6.3×11	100	8×11.5	122	10×12.5	157	10×16	188	12.5×20	248
100	6.3×11	115	6.3×11	126	8×11.5	167	10×12.5	204	10×12.5	212	10×20	273	12.5×20	343	16×25	458
220	8×11.5	202	8×11.5	221	10×12.5	294	10×16	332	10×20	375	12.5×25	506	16×25	645	18×35.5	837
330	8×11.5	247	10×12.5	322	10×16	394	10×20	444	12.5×20	526	12.5×25	620	—	—	—	—
470	10×12.5	350	10×16	420	10×20	513	12.5×20	607	12.5×25	685	16×25	861	—	—	—	—
1000	10×20	611	12.5×20	767	12.5×25	935	16×25	1120	16×31.5	1270	—	—	—	—	—	—
2200	12.5×25	1090	16×25	1380	16×31.5	1660	—	—	—	—	—	—	—	—	—	—
3300	16×25	1490	16×31.5	1760	—	—	—	—	—	—	—	—	—	—	—	—
4700	16×31.5	1880	18×35.5	2280	—	—	—	—	—	—	—	—	—	—	—	—

(Note) Rated ripple current : 85°C, 120Hz

NOTE

Design, Specifications are subject to change without notice. Ask factory for technical specifications before purchase and/or use.

Power Supply Smoothing Use, Standard Capacitors

GREEN CAP For audio

- Best suited as power supply filters for sound quality priority audio equipment.
- Printed circuit board terminal snap-in type.



Marking color : Gold print on a black sleeve



Specifications

Item	Performance					
Category temperature range (°C)	-40 to +85					
Tolerance at rated capacitance (%)	±20 (20°C, 120Hz)					
Leakage current (µA)	Less than 0.03CV or 5mA whichever is smaller (after 5 minutes) C : Rated capacitance (µF), V : Rated voltage (V) (20°C)					
Tangent of loss angle (tanδ)	Rated voltage (V)	16	25	35	50 to 100	
	tanδ (max.)	0.40	0.40	0.35	0.30	
Characteristics at high and low temperature	Rated voltage (V)	16 to 35		50 to 100		
	Impedance ratio (max.)	Z-25°C/Z+20°C	4	3		
		Z-40°C/Z+20°C	15	10		
Endurance (85°C) (Applied ripple current)	Test time	1000 hours				
	Leakage current	The initial specified value or less				
	Percentage of capacitance change	Within ±20% of initial value				
	Tangent of the loss angle	150% or less of the initial specified value				
Shelf life (85°C)	Test time : 1000 hours. Other have same as endurance. Voltage application treatment					
Applicable standards	JIS C5101-1, -4 1998 (IEC 60384-1 1992, -4 1985)					

Outline Drawing

Unit : mm

Printed circuit board snap-in type (Series LAO)

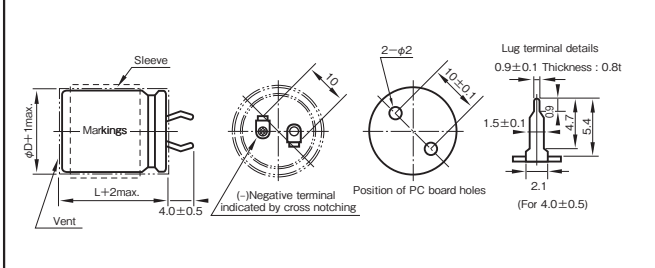

Coefficient of Frequency for Rated Ripple Current

Frequency (Hz)	50	120	1k	10k	20k
Rated voltage (V)					
50 or less	0.95	1	1.10	1.15	1.15
63 to 100	0.95	1	1.16	1.30	1.33

Part numbering system (example : 63V6800µF)

LAO	—	63	V	682	M	S57	PX #	B
Series code		Rated voltage symbol		Rated capacitance symbol	Capacitance tolerance symbol	Casing symbol		Optional symbol

NOTE

Design, Specifications are subject to change without notice.
Ask factory for technical specifications before purchase and/or use.

Standard Ratings

Rated voltage (V) Case φD×L (mm)		Item Casing symbol	16		25		35		50		63		80		100	
			Rated capacitance (μF)	Rated ripple current (Arms)	Rated capacitance (μF)	Rated ripple current (Arms)	Rated capacitance (μF)	Rated ripple current (Arms)	Rated capacitance (μF)	Rated ripple current (Arms)	Rated capacitance (μF)	Rated ripple current (Arms)	Rated capacitance (μF)	Rated ripple current (Arms)	Rated capacitance (μF)	Rated ripple current (Arms)
22×20	S21	3300	1.2	—	—	—	—	—	—	—	—	—	—	—	—	—
22×25	S22	4700	1.5	2200	1.0	1500	0.8	1000	0.8	680	0.7	—	—	—	—	—
22×30	S23	—	—	3300	1.3	2200	1.3	1500	1.1	1000	0.9	680	0.7	—	—	—
22×35	S24	6800	2.0	4700	1.7	3300	1.7	—	—	1500	1.2	1000	1.0	680	0.8	—
22×40	S25	—	—	—	—	—	—	2200	1.5	—	—	—	—	—	—	—
22×45	S26	10000	2.7	6800	2.2	4700	2.3	—	—	2200	1.6	—	—	—	—	—
22×50	S27	—	—	—	—	—	—	3300	2.0	—	—	1500	1.3	1000	1.2	—
25×25	S32	—	—	3300	1.7	2200	1.7	1500	1.4	1000	1.2	680	1.0	—	—	—
25×30	S33	6800	2.5	4700	2.1	3300	2.2	2200	1.8	1500	1.5	1000	1.2	680	1.1	—
25×35	S34	10000	3.2	—	—	—	—	—	—	—	—	—	—	—	—	—
25×40	S35	—	—	6800	2.7	4700	2.8	3300	2.3	2200	1.9	1500	1.6	1000	1.4	—
25×45	S36	—	—	—	—	—	—	—	—	—	—	—	—	—	—	—
25×50	S37	—	—	10000	3.0	6800	2.6	4700	2.4	3300	2.0	2200	2.0	1500	1.8	—
30×25	S42	6800	2.6	4700	2.2	3300	2.3	2200	1.9	1500	1.6	1000	1.3	680	1.1	—
30×30	S43	10000	3.3	6800	2.7	4700	2.8	3300	2.4	2200	1.9	1500	1.6	1000	1.4	—
30×35	S44	—	—	—	—	—	—	—	—	—	—	—	—	—	—	—
30×40	S45	—	—	10000	3.1	6800	2.7	4700	2.4	3300	2.1	2200	2.1	1500	1.8	—
30×45	S46	—	—	—	—	—	—	—	—	—	—	—	—	—	—	—
30×50	S47	—	—	—	—	10000	3.4	6800	3.1	4700	2.6	3300	2.2	2200	1.8	—
35×25	S52	10000	3.4	6800	2.8	4700	2.9	3300	2.4	2200	2.0	1500	1.7	1000	1.5	—
35×30	S53	—	—	10000	3.1	6800	2.7	4700	2.5	3300	2.1	2200	2.1	1500	1.8	—
35×35	S54	—	—	—	—	—	—	—	—	—	—	—	—	—	—	—
35×40	S55	—	—	—	—	10000	3.5	6800	3.1	4700	2.6	3300	2.2	2200	1.8	—
35×45	S56	—	—	—	—	—	—	—	—	—	—	—	—	—	—	—
35×50	S57	—	—	—	—	—	—	—	—	6800	3.3	4700	2.7	—	—	—

(Note) Rated ripple current : 85°C, 120Hz.

1 General Description of Aluminum Electrolytic Capacitors

1-1 The Principle of Capacitor

The principle of capacitor can be presented by the principle drawing as in Fig.1-1.

When a voltage is applied between the metal electrodes placed opposite on both surfaces of a dielectric, electric charge can be stored proportional to the voltage.

$$Q = C \cdot V$$

Q : Quantity of electricity (C)

V : Voltage (V)

C : Capacitance (F)

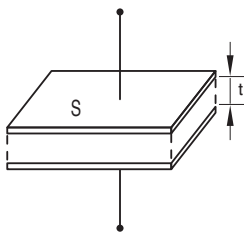

Fig.1-1

C, called the capacitance of capacitor, is expressed by the following expression with the electrode area S[m²], the electrode spacing t [m] and the dielectric constant of dielectric “ε”:

$$C[F] = \epsilon_0 \cdot \epsilon \cdot \frac{S}{t}$$

ε₀ : Dielectric constant in vacuum (=8.85×10⁻¹²F/m)

The dielectric constant of an aluminum oxide film is 7 to 8. Larger capacitances can be obtained by enlarging the electrode area S or reducing t.

Table 1-1 shows the dielectric constants of typical dielectrics used in the capacitor. In many cases, capacitor names are determined by the dielectric material used, for example, aluminum electrolytic capacitor, tantalum capacitor, etc.

Table 1

Dielectric	Dielectric Constant	Dielectric	Dielectric Constant
Aluminum oxide film	7 to 8	Porcelain (ceramic)	10 to 120
Mylar	3.2	Polystyrene	2.5
Mica	6 to 8	Tantalum oxide film	10 to 20

Although the aluminum electrolytic capacitor is small, it has a large capacitance. It is because the electrode area is roughened by electrochemical etching, enlarging the electrode area and also because the dielectric is very thin.

The schematic cross section of the aluminum electrolytic capacitor is as in Fig.1-2.

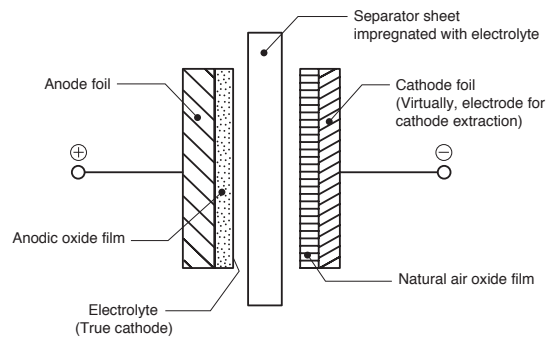
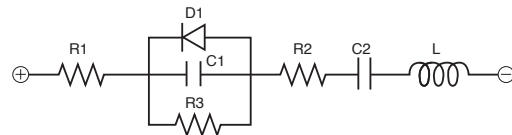

Fig.1-2

1-2 Equivalent Circuit of the Capacitor

The electrical equivalent circuit of the aluminum electrolytic capacitor is as presented in the following figure.



R1 : Resistance of terminal and electrode

R2 : Resistances of anodic oxide film and electrolyte

R3 : Insulation resistance because of defective anodic oxide film

D1 : Oxide semiconductor of anode foil

C1 : Capacity of anode foil

C2 : Capacity of cathode foil

L : Inductance caused by terminals, electrodes, etc.

2 About the Life of an Aluminum Electrolytic Capacitor

2-1 Estimation of life with minimal ripple current (negligible).

Generally, the life of an aluminum electrolytic capacitor is closely related with its ambient temperature and the life will be approximately the same as the one obtained by Arrhenius' equation.

$$L = L_0 \times 2^{\left(\frac{T_0 - T}{10}\right)} \dots \dots \dots (1)$$

Where L : Life at temperature T

L₀ : Life at temperature T₀

The effects to the life by derating of the applied voltage etc. are neglected because they are small compared to that by the temperature.

2-2 Estimation of life considering the ripple current.

The ripple current affects the life of a capacitor because the internal loss (ESR) generates heat. The generated heat will be :

$$P = I^2R \dots\dots\dots(2)$$

Where I : Ripple current (Arms)

R : ESR (Ω)

With increase in the temperature of the capacitor:

$$\Delta T = \frac{I^2 \cdot R}{A \cdot H} \dots\dots\dots(3)$$

Where ΔT : Temperature increase in the capacitor core(deg.)

I : Ripple current (Arms)

R : ESR (Ω)

A : Surface area of the capacitor (cm²)

H : Radiation coefficient (Approx. 1.5 ~ 2.0 × 10⁻³W/cm²×°C)

The above equation (3) shows that the temperature of a capacitor increases in proportion to the square of the applied ripple current and ESR, and in inverse proportion to the surface area. Therefore, the amount of the ripple current determines the heat generation, which affects the life. The value of ΔT varies depending on the capacitor types and operating conditions. The usage is generally desirable if ΔT remains less than 5°C. The measuring point for temperature increase due to ripple current is shown below ;

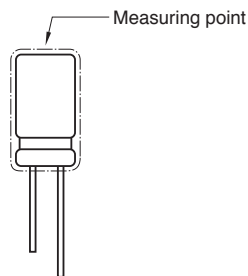

Test results:

(1) The life equation considering the ambient temperature and the ripple current will be :

$$L = L_d \times 2 \left(\frac{T_0 - T}{10} \right) \times K \left(\frac{-\Delta T}{10} \right) \dots\dots\dots(4)$$

Where L_d : Life at DC operation (h)

K : Ripple acceleration factor

(K=2, within allowable ripple current)

(K=4, if exceeding allowable ripple current)

T₀ : Upper category temperature (°C)

T : Operating temperature (°C)

ΔT : Temperature increase at capacitor core (deg.)

(2) The life equation based on the life with the rated ripple current applied under the maximum guaranteed temperature will be a conversion of the above equation (4), as below :

$$L = L_r \times 2 \left(\frac{T_0 - T}{10} \right) \times K \left(\frac{\Delta T_0 - \Delta T}{10} \right) \dots\dots\dots(5)$$

Where L_r : Life at the upper category temperature with the rated ripple current (h)

ΔT₀ : Temperature increase at capacitor core, at the upper category temperature (deg.)

(3) The life equation considering the ambient temperature and the ripple current will be a conversion of the above equation (5), as below :

$$L = L_r \times 2 \left(\frac{T_0 - T}{10} \right) \times K \left\{ 1 - \left(\frac{I}{I_0} \right)^2 \right\} \times \frac{\Delta T_0}{10} \dots\dots\dots(6)$$

Where I₀ : Rated ripple current at the upper category temperature (Arms)

I : Applied ripple current (Arms)

Since it is actually difficult to measure the temperature increase at the capacitor core, the following table is provided for conversion from the surface temperature increase to the core temperature increase.

Table 2-1

Case diameter	~10	12.5~16	18	22	25	30	35
Core / Surface	1.1	1.2	1.25	1.3	1.4	1.6	1.65

The life expectancy formula shall in principle be applied to the temperature range between the ambient temperature of +40°C and upper category temperature. The expected life time shall be about fifteen years at maximum as a guide in terms of deterioration of the sealant.

(Fig. 2-1 Life Expectancy Chart)

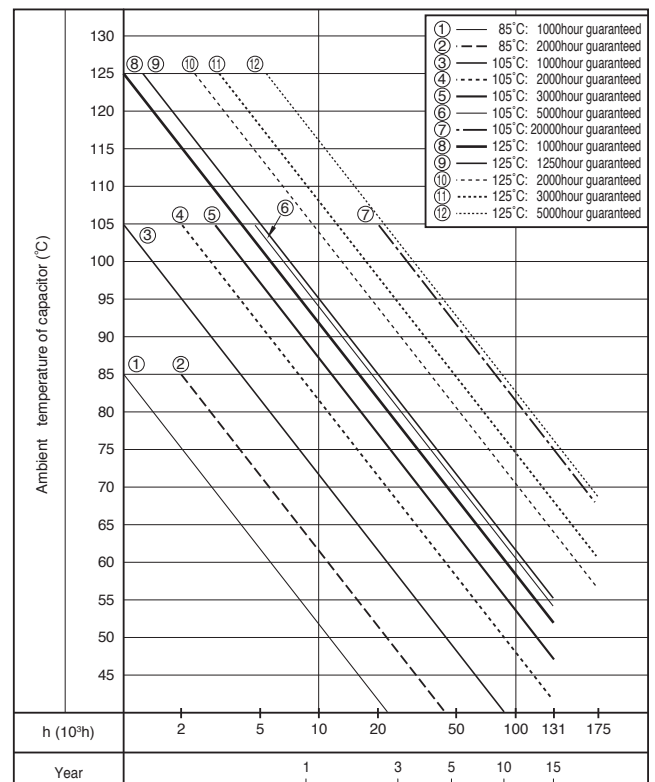

3 To calculate Balance when connecting in series

3-1 Circuit layout

Circuit for connecting two capacitors (C1, C2) in series and equivalent circuit can be illustrated as below figure. Formula to calculate a balance resistance R_B of below figure is shown as follows.

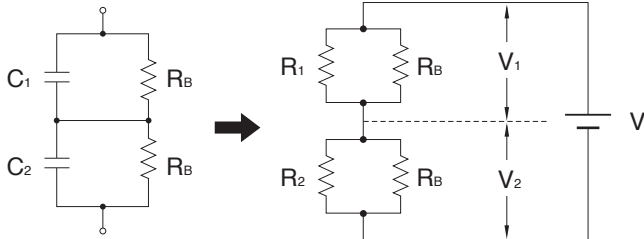

Following are the preconditions of the circuit.

- ① V_2 shall be the rated voltage ($=V_0$). ($V_1 < V_2$)
- ② V shall be a times $V_0 \times 2$. $V = 2aV_0$ ($a < 1$)
- ③ R_2 shall equal $R_1 \times b$. ($b < 1$) (1)

3-2 Formulas to calculate $[R_B]$

3-2-1 Following formula can be established from balanced condition.

$$V_1 \left[\frac{1}{R_1} + \frac{1}{R_B} \right] = V_2 \left[\frac{1}{R_2} + \frac{1}{R_B} \right] \quad (2)$$

3-2-2 Following formula can be established from preconditions.

$$V_2 \leq V_0 \quad (3)$$

$$V_1 = V - V_2 \quad (4)$$

$$= 2aV_0 - V_2 \quad (4')$$

3-2-3 Put formulas (1), (3) and (4') in formula (2).

$$(2aV_0 - V_2) \left[\frac{R_1 + R_B}{R_1 \cdot R_B} \right] = V_2 \left[\frac{bR_1 + R_B}{bR_1 \cdot R_B} \right]$$

$$2abV_0(R_1 + R_B) = V_2 \{ b(R_1 + R_B) + bR_1 + R_B \}$$

$$2ab(R_1 + R_B) \leq 2bR_1 + (1+b)R_B$$

Accordingly, balance resistance R shall be the following formula.

$$R_B \leq 2bR_1 \frac{(1-a)}{(2a-1) \cdot b-1} \quad (5)$$

3-3 Calculation Example.

Calculate the value of the balance resistance in the case of connecting two 400V 470 μ F (LC standard value : 1.88mA) capacitors in series.

$$R_1 = \frac{400(V)}{1.88(mA)} = 213(k\Omega)$$

If $a=0.8$, $400(V) \times 2 \times 0.8 = 640(V)$ as an impressed voltage.

If $b=2$, $R_2 = b R_1 = 426(k\Omega)$, $LC = 0.94(mA)$.

Balance resistance R_B will be.

$$R_B \leq 2 \times 2 \times 213(k\Omega) \frac{(1-0.8)}{(2 \times 0.8) \times 2 - 1} = 852(k\Omega)$$

4 Regarding Recovery Voltage

• After charging and then discharging the aluminum electrolytic capacitor, and further causing short-circuit to the terminals and leave them alone, the voltage between the two terminals will rise again after some interval. Voltage caused in such case is called recovery voltage. Following is the process that causes this phenomenon :

• When the voltage is impressed on a dielectric, electrical transformation will be caused inside the dielectric due to dielectric action, and electrification will occur in positive-negative opposite to the voltage impressed on the surface of the dielectric. This phenomenon is called polarization action.

• After the voltage is impressed with this polarization action, and if the terminals are discharged till the terminal voltage reaches 0 and are left open for a while, an electric potential will arise between the two terminals and thus causes recovery voltage.

• Recovery voltage comes to a peak around 10 to 20 days after the two terminals are left open, and then gradually declines. Recovery voltage has a tendency to become bigger as the component (stand-alone base type) becomes bigger.

• If the two terminals are short-circuited after the recovery voltage is generated, a spark may scare the workers working in the assembly line, and may put low-voltage driven components (CPU, memory, etc.) in danger of being destroyed. Measures to prevent this is to discharge the accumulated electric charge with resistor of about 100 to 1k Ω before using, or ship out by making the terminals in short-circuit condition by covering them with an aluminum foil at the production stage. Please consult us for adequate procedures.

5 Electrode Foil Development Technology

5-1 Corrosion inhibition of cathode foil

Inactive treatment is implemented to ensure long life by inhibiting natural corrosion of the cathode foil. Fig. 3-1 shows its effects with values of the polarization resistance inversely proportional to the corrosion rate using the AC impedance method (FRA). This indicates that the cathode foil used in the High reliability capacitors has the polarization resistance higher than that of the conventional capacitors owing to corrosion inhibition.

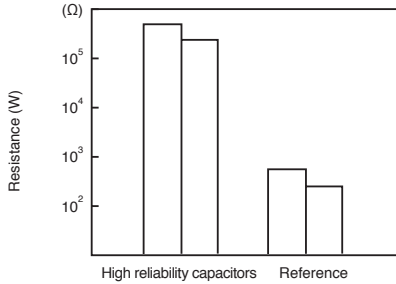

Fig. 3-1

5-2 Sealing material permeability of electrolyte

To ensure long life, a low permeable lactone solvent for the sealing material is used as the main solvent of the electrolyte of the High reliability capacitor. Fig. 3-2 shows the test results on the permeability obtained by changing the weight of the capacitors produced with different types of electrolytes at a high temperature.

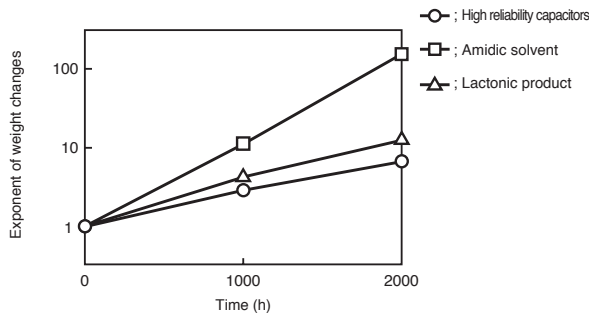

Fig. 3-2

5-3 Airtightness of sealing material

Since the electrolyte is stable for hours, the key element for capacitor's life is the sealing material. By optimizing the crosslinking density of the sealing material polymer, the sealing material of the High reliability capacitor attains its long life with electrolyte permeability less than that of the conventional capacitors.

Fig. 3-3 shows the test results on the airtightness of the sealing material obtained by changing the weight of the capacitors at a high temperature, producing capacitors with the conventional sealing material and improved one both containing the electrolyte used in the High reliability capacitor.

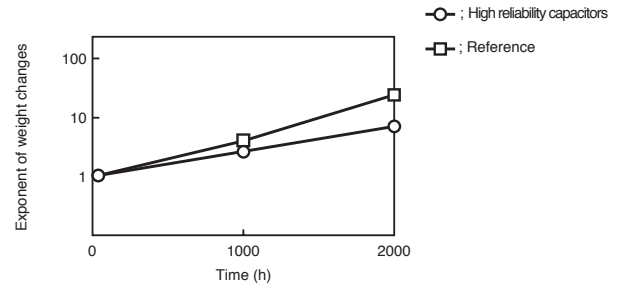

Fig. 3-3

5-4 Long-time stability of electrolyte

The electrolyte used in the High reliability capacitor is stable with low initial resistivity and small secular changes at a high temperature. Fig. 3-4 shows change in resistivity at 105°C.

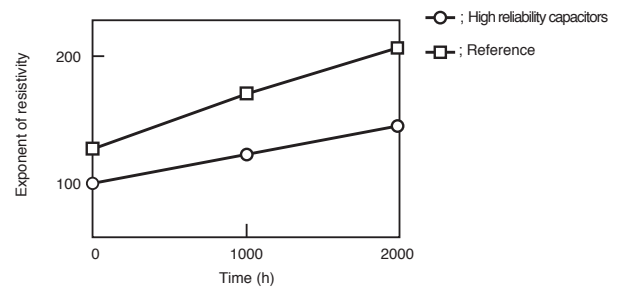

Fig. 3-4

5-5 Dielectric formation voltage and leakage current characteristics of anode foil

To increase the operating life by controlling the gas generation inside capacitor because of 1.5 to 2 times the rated voltage, while that of the previous capacitor is about 1.3 times the rated voltage.

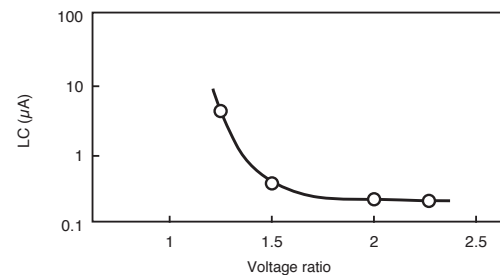

Fig. 3-5

5-6 Lowered ESR of Electrode Foil

To reduce the ESR of electrolytic capacitor, we have improved our chemical conversion technology for anode foil to develop lower ESR electrode foil compared to the conventional product as shown in Fig. 3-6

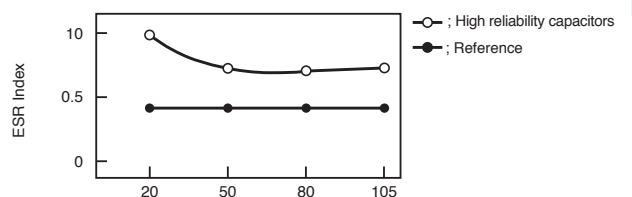
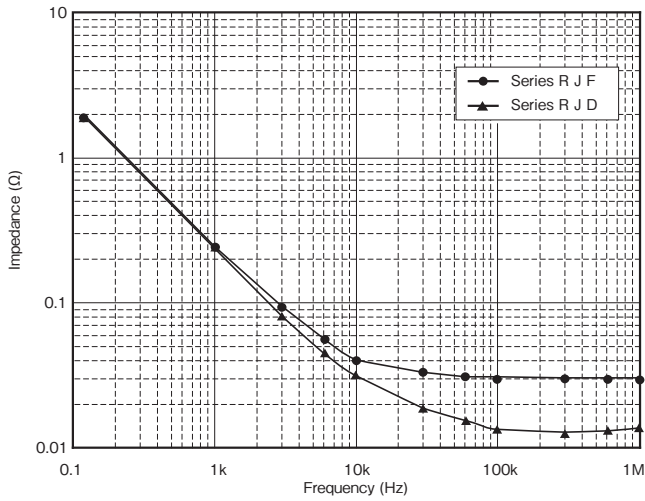

Fig. 3-6 ESR Index of Anode Foil

6. Electric Characteristics Data

6-1 Series RJF, RJB, RJD

Frequency characteristics at 20°C



Performanse	Series	R J F	R J D
Rated Voltage		35V	35V
Capacitance		680 μ F	680 μ F
Size ($\phi \times L$)		12.5 \times 20	12.5 \times 20
Impedance Spec. (20°C, 100kHz)		0.017 Ω	0.038 Ω

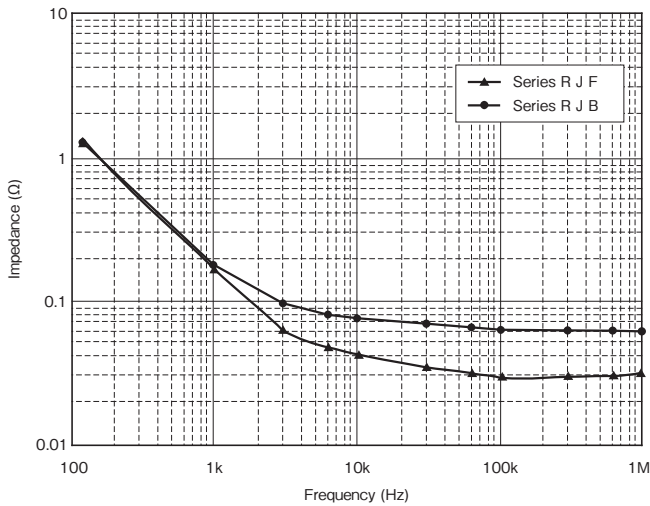

Performanse	Series	R J F	R J B
Rated Voltage		10V	10V
Capacitance		1000 μ F	1000 μ F
Size ($\phi \times L$)		10 \times 16	10 \times 16
Impedance Spec. (20°C, 100kHz)		0.038 Ω	0.080 Ω

Frequency characteristics at 20°C, -10°C

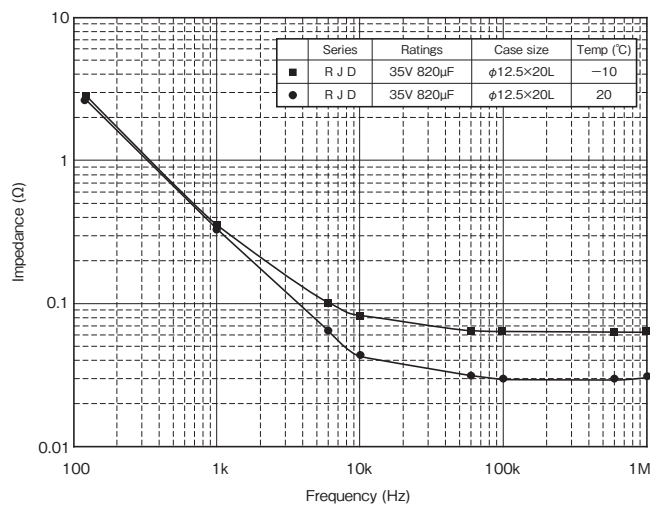

Endurance (Applied ripple current) at 105°C

Series R J D

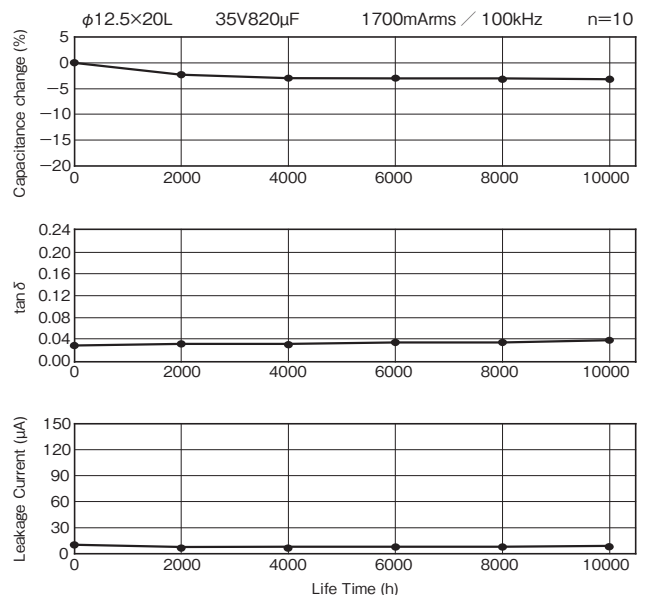

Notice : The mesurment values are not guaranteed values, but measurements.

6-2 Series RVD

Frequency characteristics at 20°C

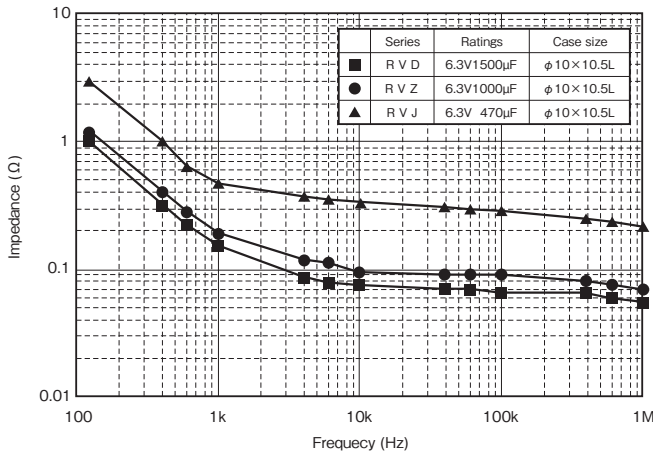

Endurance (Applied ripple current) at 105°C

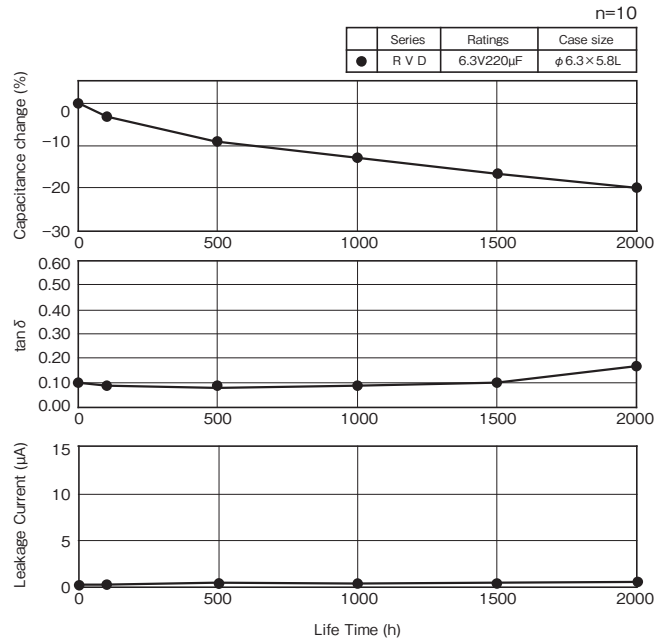

Frequency characteristics at 20°C, -40°C

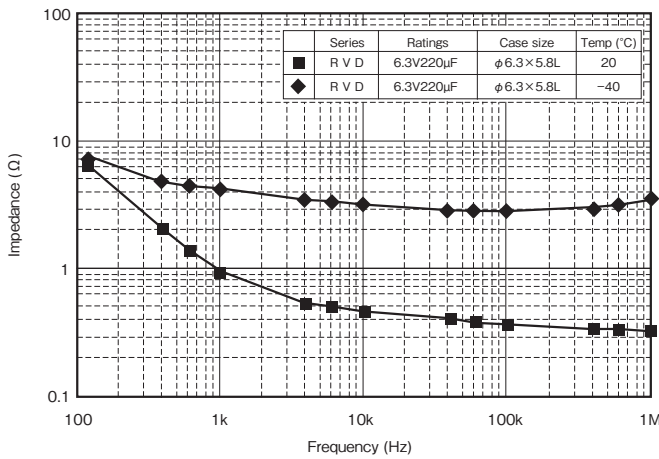

6-3 Series RKD

Endurance (Applied ripple current) at 125°C

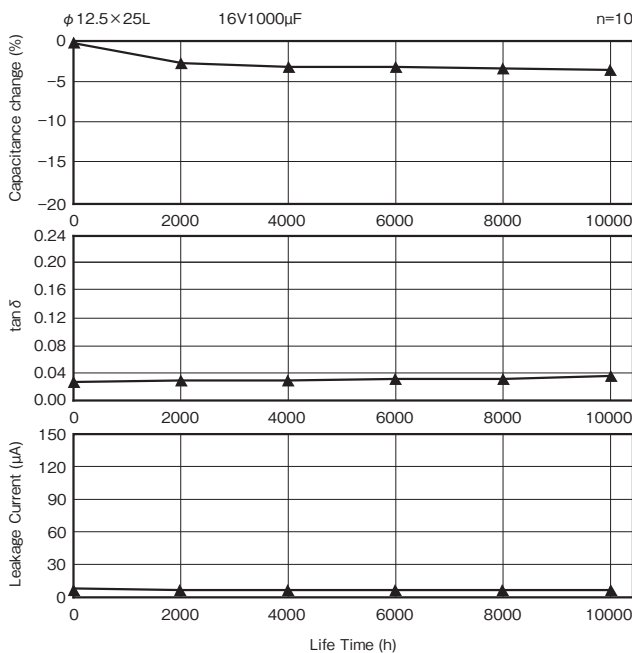

Temperature Characteristics

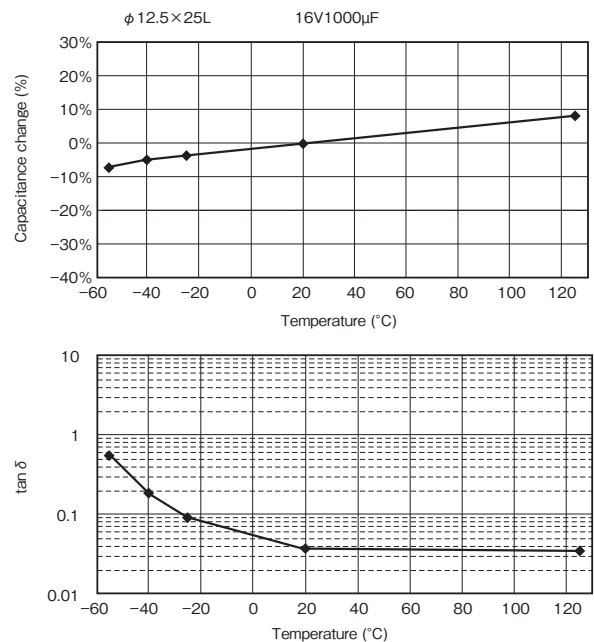

Notice : The mesurment values are not guaranteed values, but measurements.

6-4 Series LAT · LAH

Temperature characteristics, Series LAT · LAH

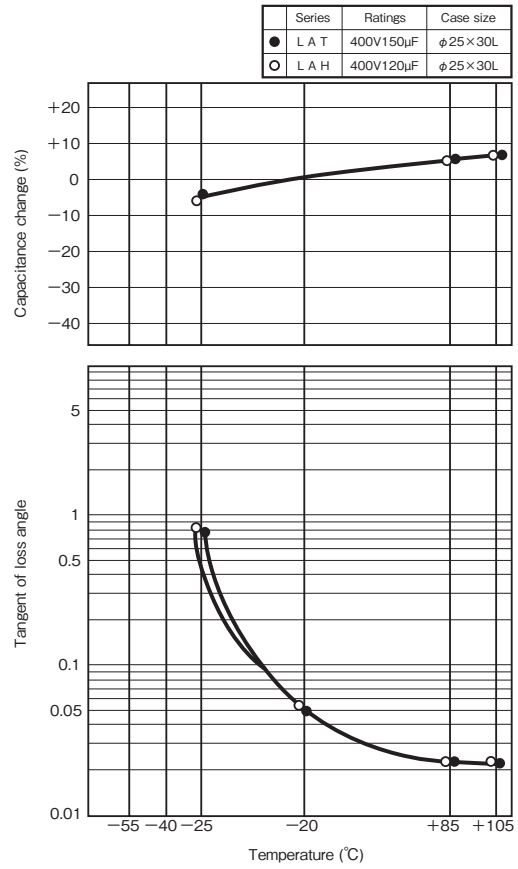
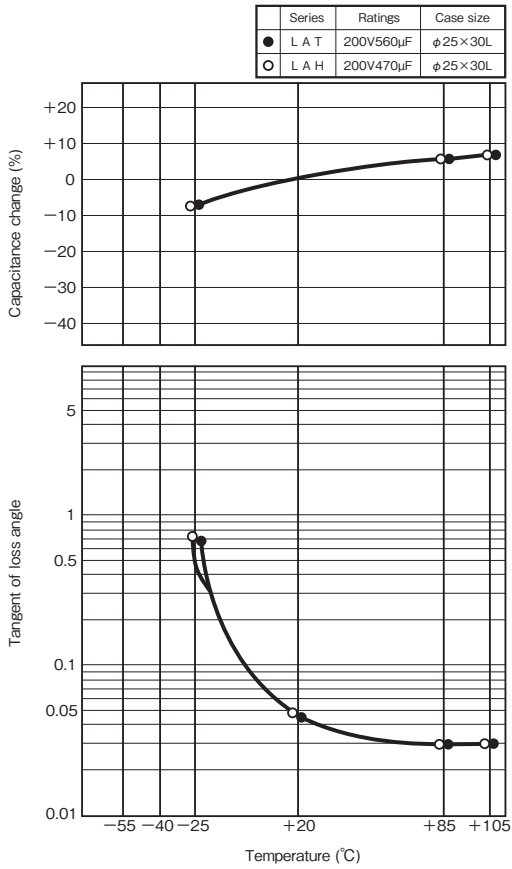

Endurance (Applied ripple current) at 105°C of Series LAT · LAH

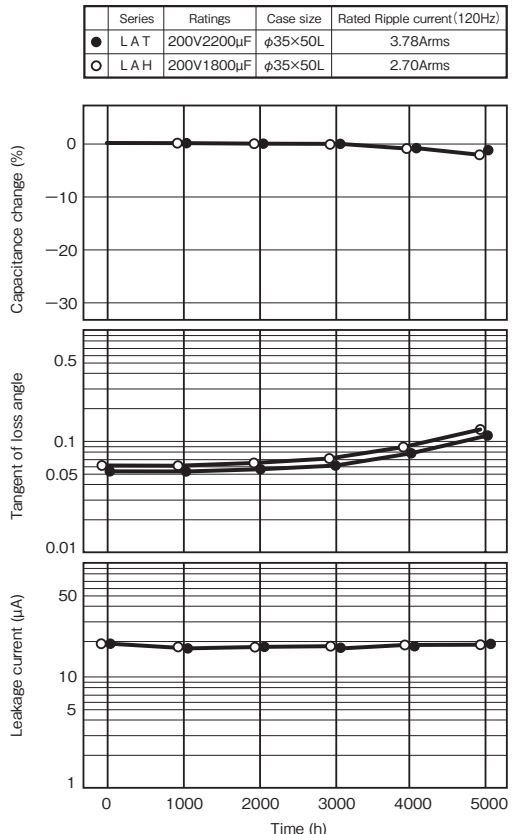
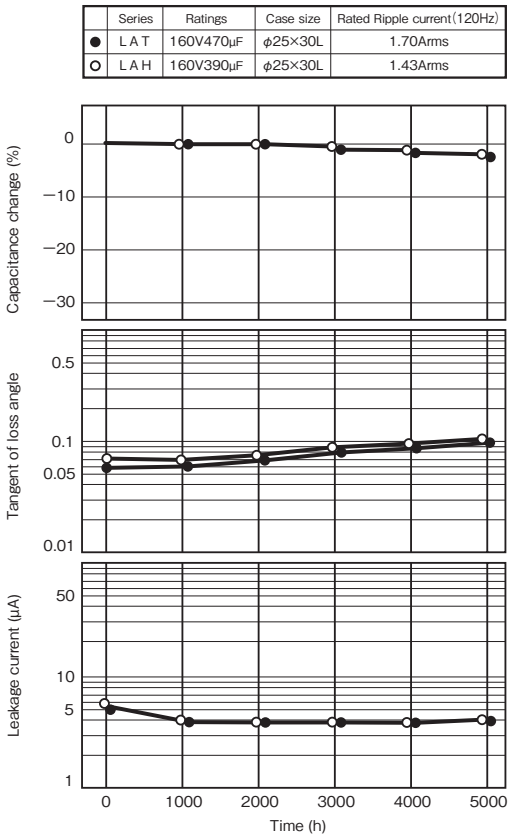

Notice : The measurement values are not guaranteed values, but measurements.

6-5 Series LAX

Temperature characteristics, Series LAX

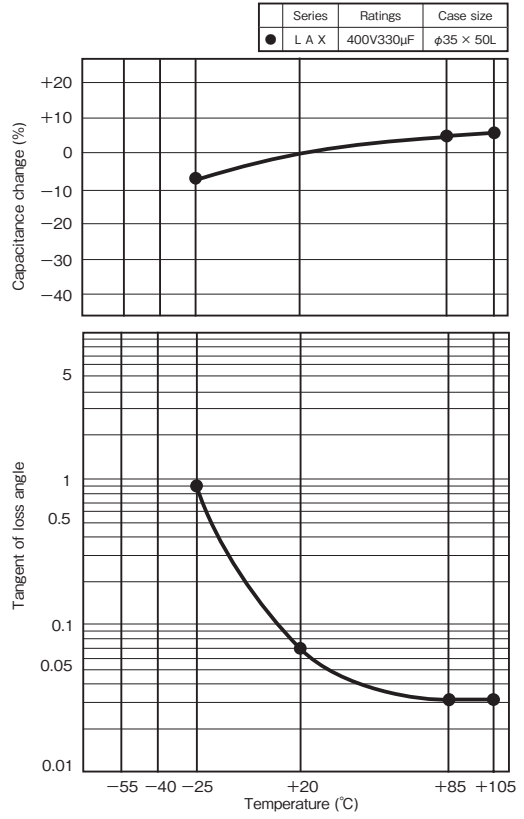
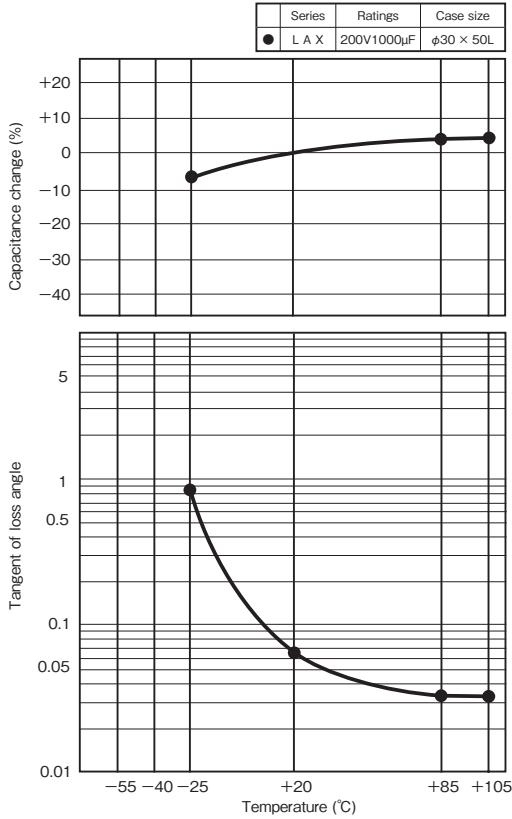

Endurance (Applied ripple current) at 105°C of Series LAX

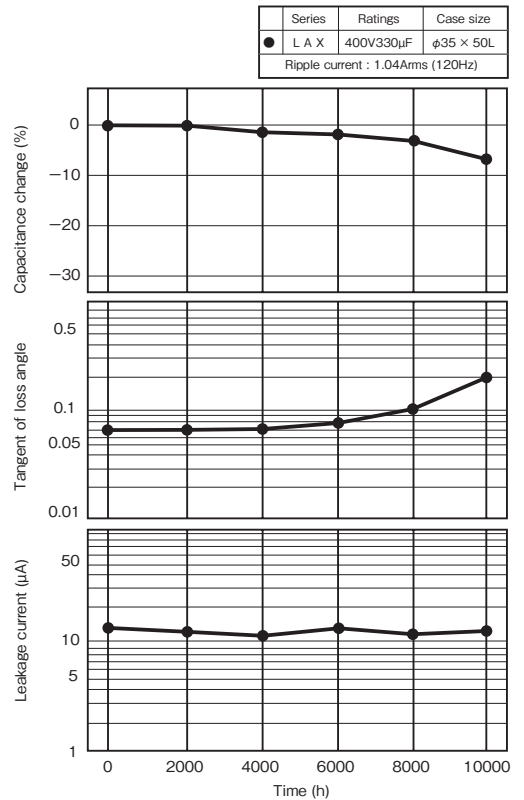
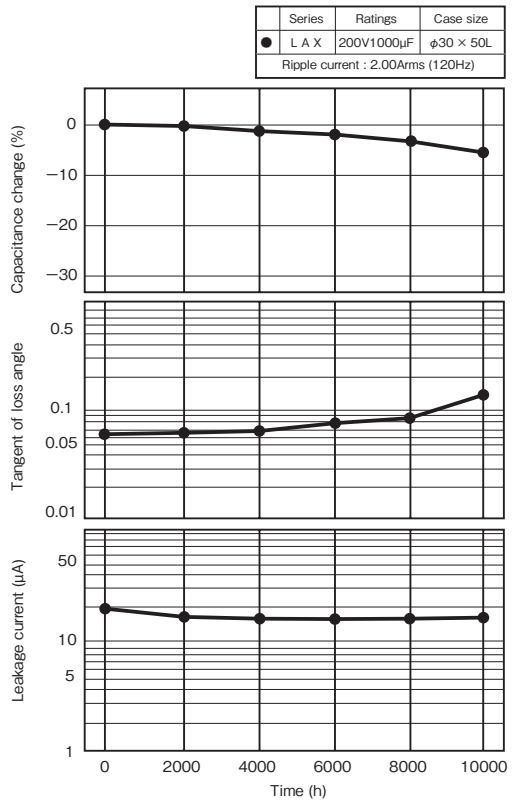

Notice : The mesurment values are not guaranteed values, but measurements.

MEMO

ELNA[®]

Electric Double Layer Capacitors “DYNACAP”, “POWERCAP”

List of Contents

1. Type List and Systematized Classification for Electric Double Layer Capacitors	178
2. Cautions for Using Electric Double Layer Capacitors	184
3. Taping	182
4. Specifications for Electric Double Layer Capacitors by Series ..	186
5. Technical Note for Electric Double Layer Capacitors	209
6. Presentation of Series and Parallel Connection Pack	212
7. Technical data for Electric Double Layer Capacitors	213

2

■ Type List for DYNACAP

★ : New series
☆ : Upgrade

Category	Series	Category temp. range °C		Max. operating voltage V.DC	Capacitance range F	Color of sleeve	Page	Applications	Remarks	
		Max.	Min.							
For memory backup	Reflow soldering type	DVN	+70	-25	5.5	0.047 ~ 0.22	Brown	186	Ideal for backing up of RTC' s, momentary backup of a battery etc.	★
	Reflow soldering type	DVL	+85	-40	5.5	0.047 ~ 0.22	Brown	187		★
	Standard type	DB	+70	-25	5.5	0.047 ~ 1.5	Indigo	188	Ideal for backing up of CMOS IC' s, microcomputers, RAM' s, RTC' s and the like used in VIDEO' s, tuners, TV sets, telephone sets, DVD and others.	
	Low profile Low ESR type	DBN	+70	-25	5.5	0.047 ~ 1.0	Indigo	188		☆
	Low profile High temperature type	DBJ	+85	-10	5.5	0.047 ~ 1.0	Black	189		
	Low profile Low ESR High temperature type	DBS	+85	-25	3.6	0.047 ~ 1.0	Black	190		☆
	Miniaturized Standard type	DX	+70	-25	5.5	0.047 ~ 1.5	Indigo	191		☆
	Miniaturized Low ESR type	DXN	+70	-25	5.5	0.047 ~ 1.5	Indigo	192	☆	
	Miniaturized High temperature type	DXJ	+85	-10	5.5	0.047 ~ 1.0	Black	193	Ideal for backing up of CMOS IC' s, microcom-puters, RAM' s, RTC' s and the like used in VIDEO' s, tuners, TV sets, telephone sets, DVD,pager units, cameras, personal wireless items and others.	
	Miniaturized Low ESR High temperature type	DXS	+85	-25	3.6	0.047 ~ 1.0	Black	194		☆
	High voltage tolerance type	DK	+70	-25	6.3	0.047 ~ 1.0	Indigo	195	Ideal for backing up of Li -batterybacked equipment such as cameras, VIDEO' s and telephone	
	High temperature type	DH	+85	-25	5.5	0.047 ~ 1.0	Indigo	196	Ideal for backing up of controls, electronic rice cooking jars, home bakeries and others.	
	Wide temperature range type	DHL	+85	-40	5.5	0.047 ~ 1.0	Indigo	197	Ideal for backing up of CMOS IC' s, microcomputers, RAM' s, RTC' s for smart meter, outdoor equipment, auto motive and industrial.	★
	High temperature long life type	DHC	+85	-25	5.5	0.047 ~ 1.0	Black	198		★
	Coin type	DC (614)	+70	-25	2.5	0.2	silver	199	Ideal for backing up of pager, solar watches, solar calculators, solar remote control units, camaras and the like.	
DCK (614)		+60	-10	3.3	0.2					
DC (621)		+70	-25	2.5	0.4					
DCK (621)		+60	-10	3.3	0.4					
Reflow soldering Coin type	DSK (414)	+70	-10	3.3	0.07	silver	200	Mountable on board with best suited for mainly memory and time functions as well as memory backup for PDA and DSC.		
	DS (614)	+70	-25	2.5	0.2					
	DSK (614)	+60	-10	3.3	0.2				201	
	DS (621)	+70	-25	2.5	0.33					
DSK (621)	+60	-10	3.3	0.33						
For power	Standard type	DZ	+70	-25	2.5	1.0 ~ 200	Black	202 203	Ideal for power supplies of LED displays, personal wireless items, backup for power supplies, and the storage battery of solar battery.	☆
	Large capacitance type	DZH	+60	-25	2.5	50 ~ 300	Black			☆
	High power type	DZN	+70	-25	2.5 / 2.7	0.7 ~ 200	Blue	204 205	Ideal for actuator of moters and electromagnetic coil drives.	☆
	Low temperature type	DY	+70	-40	2.5	1.0 ~ 33	Brown	206	Ideal for power supplies of LED displays, personal wireless items, backup for power supplies, and the storage battery of solar battery.	★
	Packed type	DZP	+70	-25	5.0	0.47 ~ 4.7	Black	207		★

■ Type List for POWERCAP

Category	Series	Category temp. range °C		Max. operating voltage V.DC	Capacitance range F	Color of sleeve	Page	Applications	Remarks
		Max.	Min.						
For energy	Large capacitance type	DP	+60	-25	2.5	500,600 1200,1500	Black	208	Ideal for power supplies of LED displays, backup for power supplies, the storage battery of solar battery, and actuator of moters and electromagnetic coil drives.

Electric Double Layer Capacitors

NOTE

Design, Specifications are subject to change without notice. Ask factory for technical specifications before purchase and/or use.

Systematized Classification of Electric Double Layer Capacitors

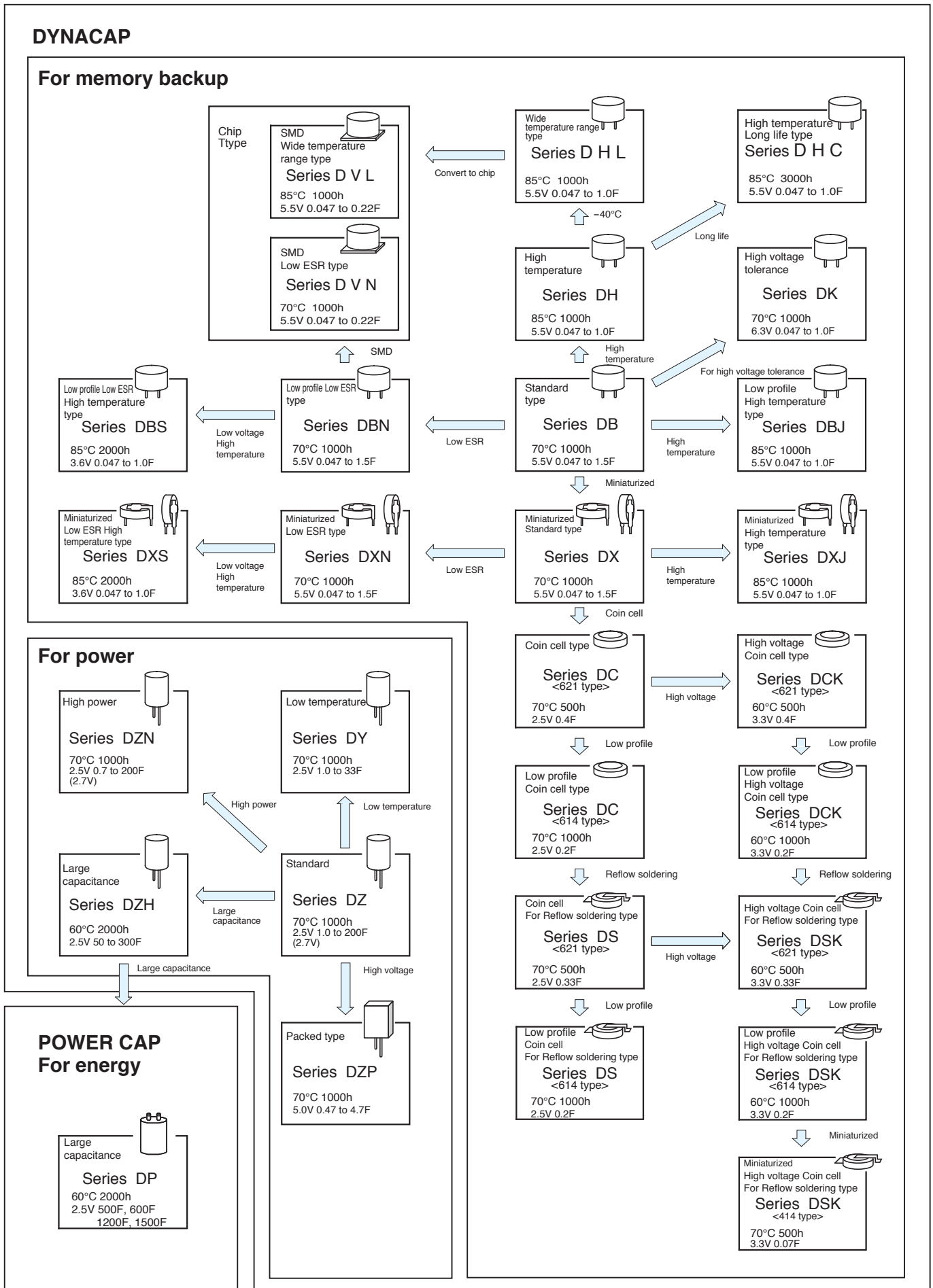

■ Product Symbol System for Electric Double Layer Capacitors

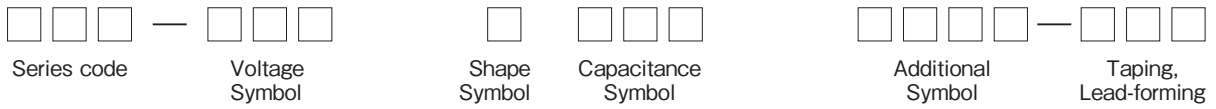

Refer to the examples on the page describing a particular series.

Leave the boxes blank when no particular designation is made.

Max. operating voltage (V)	Voltage symbol
2.5	2R5
2.7	2R7
3.3	3R3
3.6	3R6
5.5	5R5
6.3	6R3

Capacitance (F)	Capacitance symbol
0.047	473
0.1	104
0.2	204
0.22	224
0.33	334
0.47	474
0.4	404
0.68	684
1	105
1.5	155
3.3	335
4.7	475
10	106
20	206
50	506
100	107
200	207
1200	128

Write down one of the forming symbols for taping and lead-forming capacitors.

When taping or lead-forming is not necessary, leave the boxes blank.

■ Recommended soldering method (series DS, DSK, DVN, DVL)

Method	Reflow soldering	Soldering iron	Flow soldering
Advisability	○	○	×

Reflow soldering conditions.

Profile

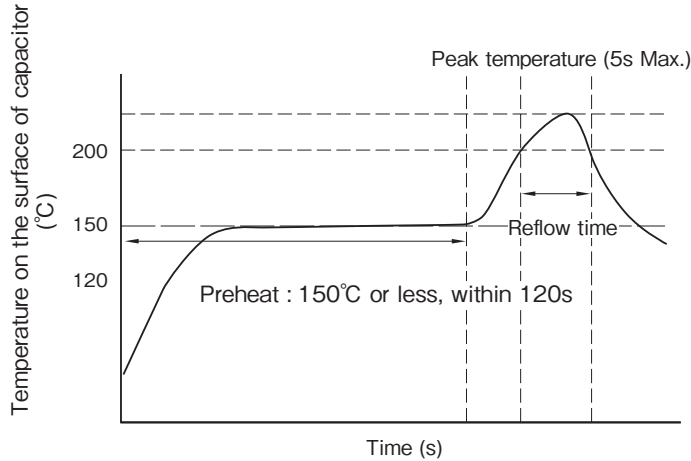

Peak temp. matrix

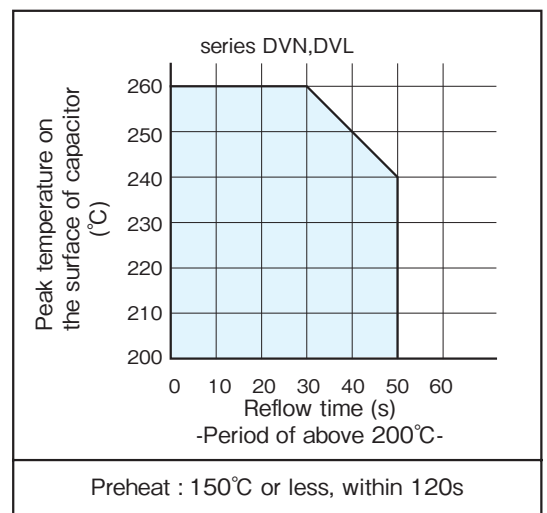
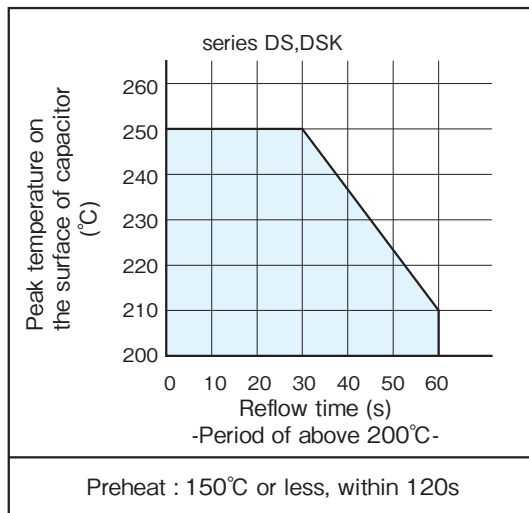

Attention : Carry out soldering work at low temperature and in the shortest time within above conditions.

Do NOT reflow solder, when cell voltage is above 0.3V.

*Please consult with us about reflow soldering conditions other than the above.

Taping

Carrier tape dimensions (Series DS, DSK) polarity L

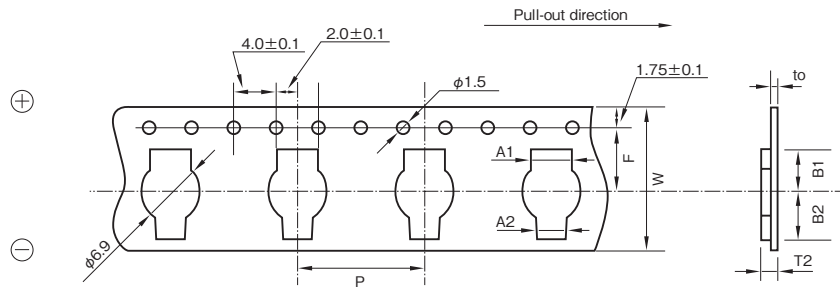

(Unit : mm)

Ourside size	W	P	F	A1	A2	B1	B2	T2	to	φD
φ6.8×1.4 to 2.1L	24±0.2	12.0	11.5	4.4	3.4	5.9	6.5	3.2	0.3	6.9
φ4.8×1.4L (Terminal shaped : HL)	16±0.2	8.0	7.5	2.4	3.6	5.0	5.1	2.45	0.3	4.9
φ4.8×1.4L (Terminal shaped : HR)	↑	↑	↑	3.6	2.4	5.1	5.0	↑	↑	↑

Reel dimensions

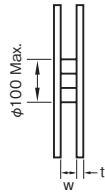
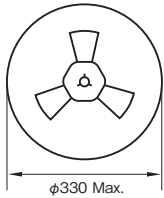

(Unit : mm)

Ourside size	W	t
φ6.8×1.4 to 2.1L	26	3
φ4.8×1.4L	18	3

Packing quantity

Ourside size	Quantity
φ6.8×2.1L	1500PCS.
φ6.8×1.4L	1500PCS. to 2000PCS.
φ4.8×1.4L	2000PCS.

Carrier tape dimensions (Series DVN, DVL) polarity R

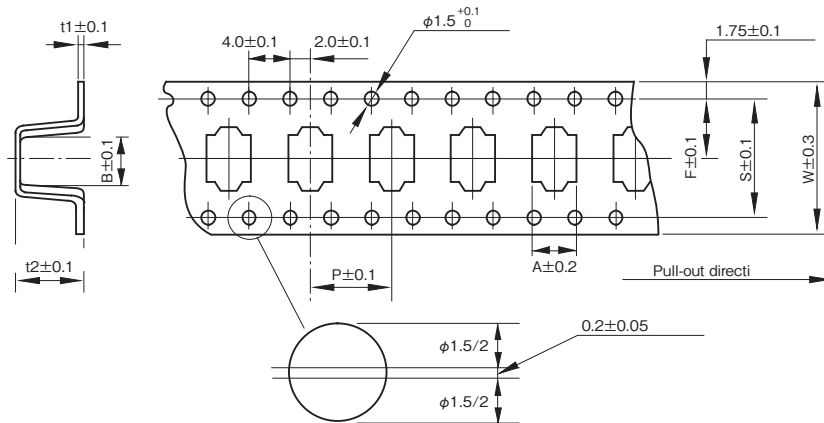

(Unit : mm)

Ourside size	W	A	B	P	t2	F	t1	S
φ12.5×10.5L	32	13.4	13.4	24	11	14.2	0.5	28.4
φ12.5× 8.5L	32	13.4	13.4	24	9.5	14.2	0.5	28.4

Reel dimensions

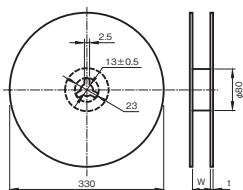

(Unit : mm)

Ourside size	W	t
φ12.5×10.5L	34	3
φ12.5× 8.5L	34	3

Packing quantity

Ourside size	Quantity
φ12.5×10.5L	250pcs.
φ12.5× 8.5L	300pcs.

NOTE

Design, Specifications are subject to change without notice.
Ask factory for technical specifications before purchase and/or use.

Standard packing specification of Coin cell type

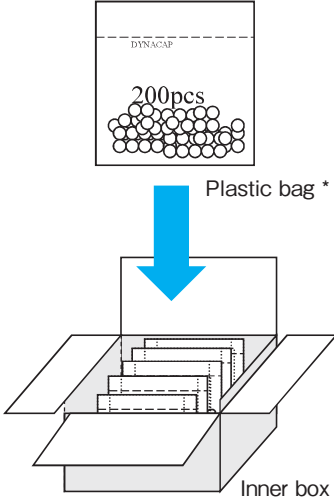
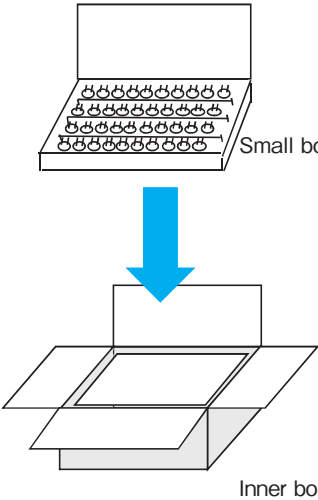
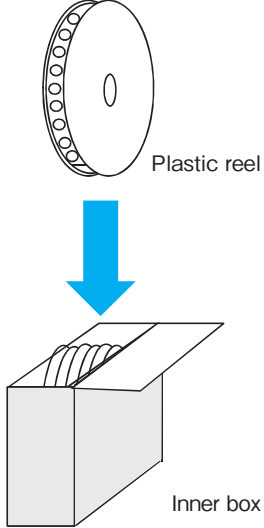
<p>Series</p>	<ul style="list-style-type: none"> • DC, DCK (614, 621) • DX, DXJ, DXN, DXS • DB, DBN, DBJ, DBS, DK, DH, DHL, DHC (φ13.5) 	<ul style="list-style-type: none"> • DB, DBN, DBJ, DBS, DK, DH, DHL, DHC (φ21.5) 	<ul style="list-style-type: none"> • DSK (414, 614, 621) • DVN, DVL
<p>Packing style</p>	 <p>Plastic bag *</p> <p>Inner box</p> <p>* DC, DCK : Vacuum packing</p>	 <p>Small box</p> <p>Inner box</p>	 <p>Plastic reel</p> <p>Inner box</p>

Standard packing specification of large type

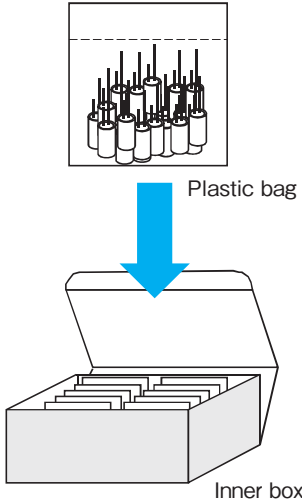
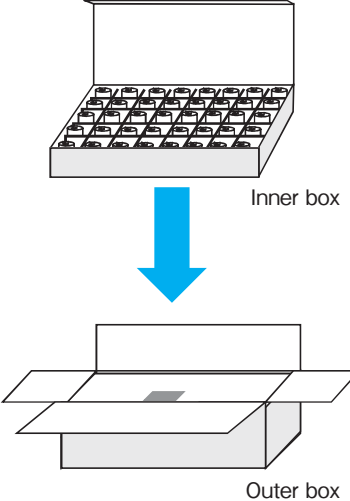
<p>Series</p>	<ul style="list-style-type: none"> • DY, DZ, DZN, DZH (φ6.3 to φ18) • DZP 	<ul style="list-style-type: none"> • DY, DZ, DZN, DZH, DP (φ22 or more)
<p>Packing style</p>	 <p>Plastic bag</p> <p>Inner box</p>	 <p>Inner box</p> <p>Outer box</p>

Please inquire for details.

Cautions for Using Electric Double Layer Capacitor (DYNACAP , POWERCAP)

■ Usage

1. Electric double layer capacitors (EDLC) use a conductive organic electrolyte.

The use at excessive mounting temperature or exceeding the upper category temperature can cause the electrolyte to leak. Especially, coin and multilayer coin types for the memory backup excluding the DZ, DZH, DZN and DP series use a low elastic plastic as the sealant in the cell construction like coin batteries; therefore, avoid using such capacitors in the vicinity of automotive equipment with steep temperature change, and heating element such as motor, relay, transformer, power IC, etc. because of the risk of leakage of electrolyte.

2. Since EDLC is polarized, do not apply a reversed voltage.

EDLC is polarized. If a reversed voltage is applied for a long time, the leakage current will increase abruptly, which may cause a decrease in the capacity, an increase in the internal resistance, and causing leakage or damage to the product in some cases.

3. Do not apply any voltage higher than the operating maximum voltage (this means the surge voltage in the case of short-time charge).

If an overvoltage is applied to the product, the leakage current will increase abruptly and the product will become overheated, which may cause a decrease in the capacity, an increase in the internal resistance, and causing leakage or damage to the product in some cases.

4. Do not use smoothing a power supply (for absorbing its ripple).

Since the internal resistance of EDLC is high, the product will be overheated if it is used for smoothing a power supply (for absorbing its ripple), which may cause a decrease in the capacity, an increase in the internal resistance, and causing leakage or damage to the product in some cases .

5. Do not use in a circuit where quick charge and discharge are repeated Very often.

In a circuit where quick charge and discharge are repeated very often , the product will become overheated, which may cause a decrease in the capacity, an increase in the internal resistance, and causing leakage or damage to the product in some cases.

Reduce the charge and discharge currents while selecting a product with low internal resistance, and make sure that the product surface temperature does not rise.

6. EDLC life depends heavily on the ambient temperature.

①The lifetime of EDLC is seriously affected by change in ambient temperature. If the temperature is lowered by 10°C, the lifetime will be approximately doubled. Therefore, the product should be used at a temperature lower than the guaranteed maximum value for maximum life.

②If the capacitor is used at a temperature exceeding its maximum guaranteed temperature, not only is its life shortened, but increased vapor

pressure of electrolyte or electrochemical reactions may increase the internal pressure, and causing leakage or damage to the product in some cases.

7. Note that a voltage drop in EDLC occurs during backup.

In a case where discharge current is large, or a large current flows instantaneously, an electric double layer capacitor may not operate at the start of discharge because of a large voltage drop (IR drop) caused by the product with the DC internal resistance.

Please consult us for a large discharge current (in the case of other series except DZ, DZH, DZN and DP series: when larger than 1 (mA) = 100 (F)) as the internal resistance varies by each series (Recommendation discharge current: less than 1 mA/F at 20°C)

8. Do not use the product in an ambient atmosphere containing waterdrops (condensation) or toxic gases.

Although EDLC is sealed, water droplets or toxic gases may do degradation characteristics, a leakage and corrode the lead wires and the case, which may cause a breaking of the wires.

Avoid abrupt temperature changes, which may cause water droplets, resulting in product deterioration and electrolyte leakage.

9. Contact us before connecting the products in series.

A series connection will cause imbalance in the voltage, charged to the capacitors and an overvoltage may be charged to one or more them. This may cause a decrease in the capacity, an increase in the internal resistance and causing leakage or damage to the product in some cases. When using series connection for several capacitors, please derate the applied voltage from the operating maximum voltage or use balancing circuits (bleeder resistor, etc.) to compensate for the imbalance in the applied voltage for each capacitor. Moreover, please ensure the arrangement does not cause temperature fluctuation between capacitors.

10.About vibration.

A terminal blank, a terminal bend, and a crease may occur by adding too much vibration to a capacitor.

Moreover, depending on the case, an EDLC may do degradation of the characteristic, breakage, and a leakage.

When you become too much vibration, please contact us.

11.When used on a double sided printed circuit board, do not overlap the wiring patterns on the mounted part .

A short circuit may be created by certain wiring conditions. Should the electrolyte leaks, the circuit pattern may cause a short circuit, resulting in tracking or migration.

12.Do not keep in high temperature and high humidity atmospheres.

①Avoid high temperature or high humidity or direct rays when storing capacitors.

NOTE

Design, Specifications are subject to change without notice. Ask factory for technical specifications before purchase and/or use.

②Keep the product in a place where the temperature is 5°C~30°C and the humidity is lower than 60%. Avoid an abrupt temperature change, which may cause condensation or deterioration of the product or liquid leakage.

③Do not store EDLC at a place where there is a possibility that they may get water, salt or oil spill.

④Do not store EDLC at place where the air contains dense hazardous gas (hydrogen sulfide, sulfurous acid, nitrous acid, chlorine ammonia, etc.).

⑤Do not store EDLC at a place where it gets ultraviolet ray or radioactive ray.

13. Capacitors fitted with a relief valve

①The relief valve is provided with a valve function with part of the case made thin to avoid explosion by increased internal pressure when the capacitor is under abnormal load such as overvoltage or reverse voltage. After activation of the relief valve, the capacitor must be replaced as it does not restore.

②For the capacitors with a case relief valve, provide a void on the top of the relief valve so as not to hamper its activation. Make a void of 2 mm or more for the product of $\phi 18$ or less in diameter, and a void of 3 mm or more for the product of $\phi 20$ to $\phi 35$ mm in diameter on the top.

14. Use at a high altitude

The use of capacitors at high altitudes such as on an airplane causes a large difference between the internal pressure of the capacitors and the atmospheric pressure.

However, there is no problem in use under atmospheric pressure up to about an altitude of 10,000 meters.

If the condition is severe like space, please contact us.

■ Mounting

1. Do not overheat when soldered.

Depending on the type and size of the board, the product may be subjected to overheat, leading to loss of airtightness. This may greatly shorten the product life or cause liquid leakage.

In case of a 1.6mm-thick and single side printed board. for example, keep the following soldering conditions: temperature lower than 260°C, time shorter than 5 seconds.

When a board thinner than 1.6 mm or multi-layer printed board is used, contact us.

In the case of hand soldering, the iron tip temperature is lower than 360°C, time is shorter than 3 seconds.

The coin types and multilayer coin types excluding the DZ and reflow-compatible coin types use polypropylene as the packing material for sealing and therefore susceptible to excessive heat. Note that the component body temperature shall be controlled so as not to exceed 90°C including preheating.

2. When soldering the capacitor to the wiring board, do not attach the body of the capacitor to the circuit board.

If the body of the capacitor is attached directly to the circuit board, the flux or solder can blow through the through holes in the circuit board, negatively impacting the capacitor.

Moreover, the heat influence at the time of soldering can be reduced by floating the body.

3. Contact us when cleaning is necessary after soldering.

Certain types of solvents are not compatible and may cause damage.

4. Contact us when the product is attached by adhesive bonding.

Certain types of adhesives are not compatible. Paste bond partially between the product and the board so that the product will not adhere completely to the board.

Do not raise the temperature over the guaranteed value while the bond is hardening.

5. Heating conditions of adhesive curing oven

During heating of the adhesive curing oven, application of excessive heat may significantly shorten the product life or cause liquid leakage. Control the body temperature so as not to exceed 90°C during work while setting the allowable atmospheric temperature below 110°C, and allowable heating time within 30 seconds.

For the heating conditions deviating from the above, consult with us providing your temperature profile conditions.

6. Be careful not to apply an excessive force to the capacitor body, terminals or lead wires.

①Mount the capacitor while making sure that the terminal spacing of the capacitor and the spacing of the holes in the printed wiring board are aligned.

②If the capacitor body is subjected to stress such as grabbing, falling, bend, pushing or twisting after mounted, its terminals may come off, leading to open, short or liquid leakage.

■ Other cautions

1. Emergency procedures

If the EDLC overheats or starts to smell, immediately switch off the units main power supply to stop operation.

Keep your face and hands away from the EDLC, since the temperature may be high enough to cause the EDLC to ignite and burn.

2. Periodical inspections should be established for the EDLC used in industrial appliances.

The following items should be checked:

①Appearance : Check if there is leakage.

②Electronic performance : Check the leakage current, the electrostatic, the internal resistance and other items described in the catalog or the product specifications.

3. Disposing of EDLC.

①Punch a hole or crush the EDLC (to prevent explosion) before incineration at approved facility.

②If they are not to be incinerated, bring them to a professional industrial waste disposal company.

4. Other notes.

Please refer to the following literature for anything not described in the product specifications or the catalog. (Technical Report of Japan Electronics and Information Technology Industries Association #EIAJ RCR-2370B "Guideline of notabilia for fixed electric double layer capacitors")

NOTE

Design, Specifications are subject to change without notice.
Ask factory for technical specifications before purchase and/or use.

5.5V SMD, Low Resistance

GREEN CAP

70°C

- Size : $\phi 12.5 \times 8.5$ mm, compatible with surface mounting and low ESR.
- Unlike batteries, safe and high reliability without containing active and hazardous substance.
- Unlike batteries, excellent charge and discharge characteristics with no chemical reactions.
- Responds to temperature 260°C during the reflow peek.



Marking color : White print on an brown sleeve

Convert to chip



Specifications

Item	Performance			
Category temperature range (°C)	- 25 to +70			
Tolerance at rated capacitance (%)	- 20 to +80			
Internal resistance at 1 kHz	Rated Capacitance (F)	0.047	0.1	0.22
	Internal resistance (Ω)	30	30	30
Characteristics at high and low temperature	Percentage of capacitance change	Within $\pm 30\%$ of the value at 20°C		
	Internal resistance	Less than five times of the value at 20°C		
Endurance (70°C)	Test time	1000 hours		
	Percentage of capacitance change	Within $\pm 30\%$ of the initial measured value		
	Internal resistance	Less than four times of the initial specified value		
Shelf life (70°C)	Test time : 1000 hours ; Same as endurance.			
Applicable standards	Conforms to JIS C5160-1 2009 (IEC 62391-1 2006)			

Outline Drawing

Unit : mm

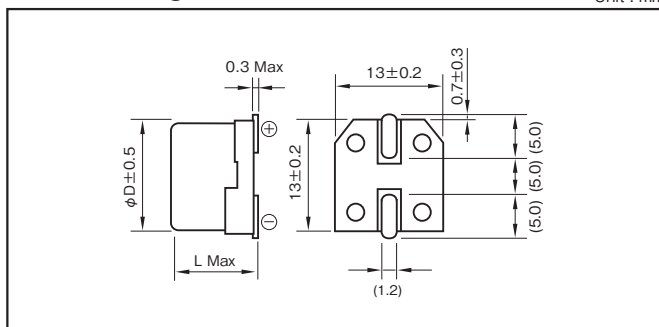

Recommended land pattern size

Unit : mm

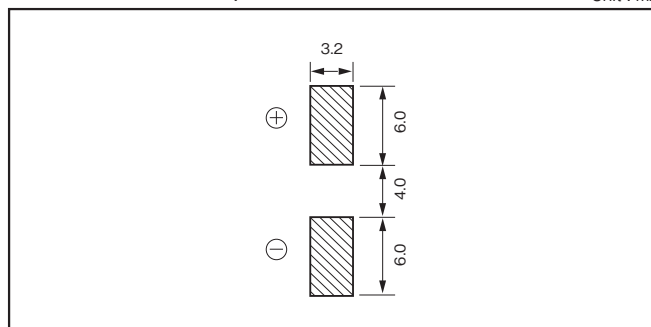

Part numbering system (example : 5.5V0.1F)

DVN	5R5	—	D	104	T	—	R5
Series code	Rated voltage symbol		Terminal code	Rated capacitance symbol			Taping symbol

Part number is refer to below table.

Standard Ratings

Max. operating voltage (V)	Rated capacitance (F)	ELNA Parts No.	$\phi D \times L$ (mm)
5.5	0.047	DVN-5R5D473T-R5	12.5×8.5
5.5	0.1	DVN-5R5D104T-R5	12.5×8.5
5.5	0.22	DVN-5R5D224T-R5	12.5×8.5

*soldering conditions are described on page 181.

NOTE

Design, Specifications are subject to change without notice. Ask factory for technical specifications before purchase and/or use.

5.5V SMD, Wide Temperature range

GREEN CAP

85°C

- Size : $\phi 12.5 \times 10.5$ mm, compatible with surface mounting.
- Wide temperature range (-40 to 85°C), Low ESR.
- Unlike batteries, safe and high reliability without containing active and hazardous substance.
- Unlike batteries, excellent charge and discharge characteristics with no chemical reactions.
- Responds to temperature 260°C during the reflow peak.



Marking color : White print on an brown sleeve

Convert to chip



Specifications

Item	Performance			
Category temperature range (°C)	-40 to $+85$			
Tolerance at rated capacitance (%)	-20 to $+80$			
Internal resistance at 1 kHz	Rated Capacitance (F)	0.047	0.1	0.22
	Internal resistance (Ω)	45	45	45
Characteristics at high and low temperature	Percentage of capacitance change	Within $\pm 30\%$ of the value at 20°C		
	Internal resistance	-40°C : Less than seven times of the value at 20°C 85°C : Less than five times of the value at 20°C		
Endurance (85°C)	Test time	1000 hours		
	Percentage of capacitance change	Within $\pm 30\%$ of the initial measured value		
	Internal resistance	Less than four times of the initial specified value		
Shelf life (85°C)	Test time : 1000 hours ; Same as endurance.			
Applicable standards	Conforms to JIS C5160-1 2009 (IEC 62391-1 2006)			

Outline Drawing

Unit : mm

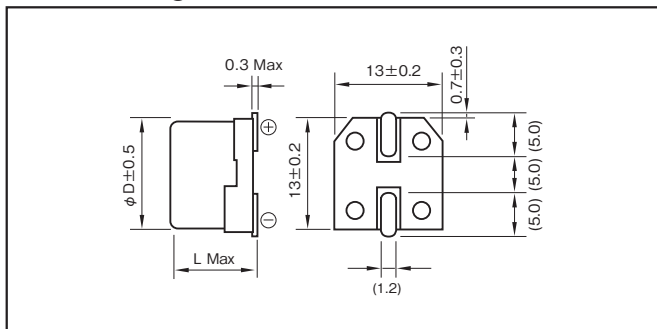

Recommended land pattern size

Unit : mm

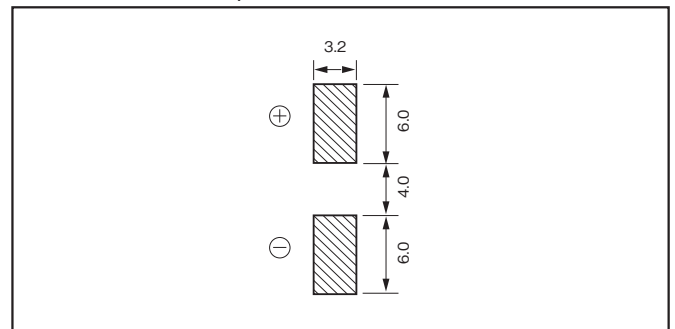

Part numbering system (example : 5.5V0.1F)

DVL	5R5	—	D	104	T	—	R5
Series code	Rated voltage symbol		Terminal code	Rated capacitance symbol			Taping symbol

Part number is refer to below table.

Standard Ratings

Max. operating voltage (V)	Rated capacitance (F)	ELNA Parts No.	$\phi D \times L$ (mm)
5.5	0.047	DVL-5R5D473T-R5	12.5×10.5
5.5	0.1	DVL-5R5D104T-R5	12.5×10.5
5.5	0.22	DVL-5R5D224T-R5	12.5×10.5

*soldering conditions are described on page 181.

NOTE

Design, Specifications are subject to change without notice.
Ask factory for technical specifications before purchase and/or use.

5.5V Standard Capacitors Series DB

GREEN CAP 70°C

- Small-sized, large capacity, excellent voltage holding.
- For all ratings, uniform 5mm pitch of terminal spacing.
- Wider temperature range (-25 to +70°C) than battery.
- $\phi 21.5 \times 7.5$ size can encase up to 1.5F.
- Ideal for backing up of CMOS's, IC's, microcomputers, RAM's, RTC's and the like used in Video's, tuners, TV sets, telephone sets and others.



Marking color : White print on an indigo sleeve

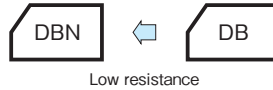

Specifications

Item	Performance								
Category temperature range (°C)	-25 to +70								
Tolerance at rated capacitance (%)	-20 to +80								
Internal resistance at 1 kHz	Rated capacitance (F)	0.047	0.1	0.22	0.33	0.47	0.47	1.0	1.5
	Internal resistance (Ω)	120	75	75	75	75 ($\phi 13.5$)	30 ($\phi 21.5$)	30	30
Characteristics at high and low temperature	Percentage of capacitance change	Within $\pm 30\%$ of the value at 20°C							
	Internal resistance	Less than five times of the value at 20°C							
Endurance (70°C)	Test time	1000 hours							
	Percentage of capacitance change	Within $\pm 30\%$ of the initial measured value							
	Internal resistance	Within four times of the initial specified value							
Shelf life (70°C)	Test time : 1000 hours ; Same as endurance.								
Applicable standards	Conforms to JIS C5160-1 2009 (IEC 62391-1 2006)								

Outline Drawing

Unit : mm

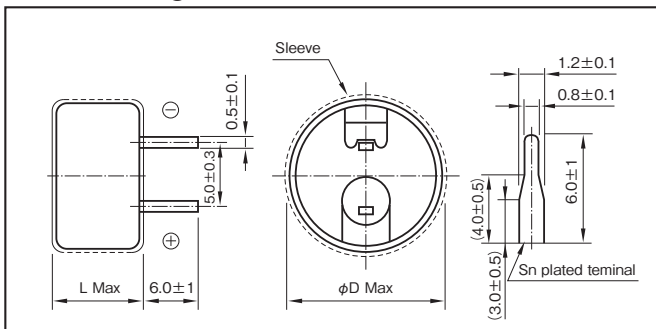

Standard Ratings

Max. operating voltage (V)	Rated capacitance (F)	ELNA Parts No.	$\phi D \times L$ (mm)
5.5	0.047	DB-5R5D473T	13.5×7.5
5.5	0.1	DB-5R5D104T	13.5×7.5
5.5	0.22	DB-5R5D224T	13.5×7.5
5.5	0.33	DB-5R5D334T	13.5×7.5
5.5	0.47	DB-5R5D474ST	13.5×7.5
5.5	0.47	DB-5R5D474T	21.5×8.0
5.5	1.0	DB-5R5D105T	21.5×8.0
5.5	1.5	DB-5R5D155T	21.5×8.0

Part numbering system (example : 5.5V0.1F)

DB	—	5R5	D	104		T
Series code		Rated voltage symbol	Terminal code	Rated capacitance symbol		Additional symbol

Part number is refer to above table.

5.5V Low Resistance Series DBN

GREEN CAP 70°C Low ESR

- Internal resistance was reduced to 85% to DB series.
- It excels in rapid charge.(It can charge and discharge with 1.5 times as much current (mA) as rated capacitance.)

Specifications

Item	Performance								
Category temperature range (°C)	-25 to +70								
Tolerance at rated capacitance (%)	-20 to +80								
Internal resistance at 1 kHz	Rated capacitance (F)	0.047	0.1	0.22	0.33	0.47	0.47	1.0	1.5
	Internal resistance (Ω)	25	25	25	25	25 ($\phi 13.5$)	20 ($\phi 21.5$)	20	20
Characteristics at high and low temperature	Percentage of capacitance change	Within $\pm 30\%$ of the value at 20°C							
	Internal resistance	Less than five times of the value at 20°C							
Endurance (70°C)	Test time	1000 hours							
	Percentage of capacitance change	Within $\pm 30\%$ of the initial measured value							
	Internal resistance	Within four times of the initial specified value							
Shelf life (70°C)	Test time : 1000 hours ; Same as endurance.								
Applicable standards	Conforms to JIS C5160-1 2009 (IEC 62391-1 2006)								

Standard Ratings

Max. operating voltage (V)	Rated capacitance (F)	ELNA Parts No.	$\phi D \times L$ (mm)
5.5	0.047	DBN-5R5D473T	13.5×7.5
5.5	0.1	DBN-5R5D104T	13.5×7.5
5.5	0.22	DBN-5R5D224T	13.5×7.5
5.5	0.33	DBN-5R5D334T	13.5×7.5
5.5	0.47	DBN-5R5D474ST	13.5×7.5
5.5	0.47	DBN-5R5D474T	21.5×8.0
5.5	1.0	DBN-5R5D105T	21.5×8.0
5.5	1.5	DBN-5R5D155T	21.5×8.0

Part numbering system (example : 5.5V0.047F)

DBN	—	5R5	D	473		T
Series code		Rated voltage symbol	Terminal code	Rated capacitance symbol		Additional symbol

Part number is refer to left table.

NOTE

Design, Specifications are subject to change without notice. Ask factory for technical specifications before purchase and/or use.

5.5V Low profile and high temperature Capacitors

GREEN CAP 85°C

- High temperature type of series DB.
- Small-sized, large capacity, excellent voltage holding.
- For all ratings, uniform 5mm pitch of terminal spacing.
- $\phi 13.5 \times 7.5$ e size can encase up to 1F.
- Ideal for backing up of CMOS's, IC's, microcomputers, RAM's, RTC's and the like used in Video's, tuners, TV sets, telephone sets and others.

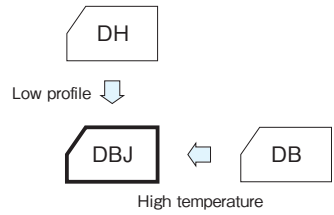

Marking color : White print on a black sleeve

Specifications

Item	Performance						
Category temperature range (°C)	-10 to +85						
Tolerance at rated capacitance (%)	-20 to +80						
Internal resistance at 1 kHz	Rated Capacitance (F)	0.047	0.1	0.22	0.33	0.47	1.0
	Internal resistance (Ω)	200	150	150	150	100	75
Characteristics at high and low temperature	Percentage of capacitance change	Within $\pm 30\%$ of the value at 20°C					
	Internal resistance	Within four times of the initial specified value					
Endurance (85°C)	Test time	1000 hours					
	Percentage of capacitance change	Within $\pm 30\%$ of the initial measured value					
	Internal resistance	Less than four times of the initial specified value					
Shelf life (85°C)	Test time : 1000 hours ; Same as endurance.						
Applicable standards	Conforms to JIS C5160-1 2009 (IEC 62391-1 2006)						

Outline Drawing

Unit : mm

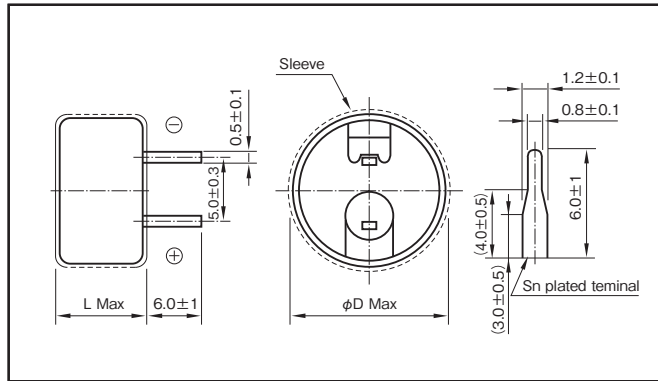

Part numbering system (example : 5.5V0.1F)				
DBJ	—	5R5	D	104 T
Series code		Max.operating voltage symbol		Rated capacitance symbol

Part number is refer to below table.

Standard Ratings

Max. operating voltage (V)	Rated capacitance (F)	ELNA Parts No.	$\phi D \times L$ (mm)
5.5	0.047	DBJ-5R5D473T	13.5×7.5
5.5	0.1	DBJ-5R5D104T	13.5×7.5
5.5	0.22	DBJ-5R5D224T	13.5×7.5
5.5	0.33	DBJ-5R5D334T	13.5×7.5
5.5	0.47	DBJ-5R5D474T	21.5×8.0
5.5	1.0	DBJ-5R5D105T	21.5×8.0

3.6V Low Profile and Low ESR High temperature

GREEN CAP

85°C

- Long life of 3.6V 2000 hours in small size low ESR.
- For all ratings, uniform 5mm pitch of terminal spacing.
- Wider temperature range (-25 to +85°C) than battery.
- $\phi 13.5 \times 7.5$ ℓ size can encase up to 0.47F.
- Ideal for backing up of CMOS's, IC's, microcomputers, RAM's, RTC's and the like used in Video's, tuners, TV sets, telephone sets and others.
- It excels in rapid charge.



Marking color : White print on a black sleeve

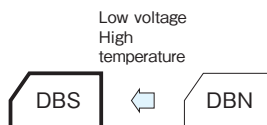

Specifications

Item	Performance							
Category temperature range (°C)	-25 to +85							
Tolerance at rated capacitance (%)	-20 to +80							
Internal resistance at 1 kHz	Rated Capacitance (F)	0.047	0.1	0.22	0.33	0.47	0.47	1.0
	Internal resistance (Ω)	25	25	25	25	25 ($\phi 13.5$)	20 ($\phi 21.5$)	20
Characteristics at high and low temperature	Percentage of capacitance change	Within $\pm 30\%$ of the value at 20°C						
	Internal resistance	Less than five times of the value at 20°C						
Endurance (85°C)	Test time	2000 hours ($\phi 13.5$ 0.047F : 1000 hours)						
	Percentage of capacitance change	Within $\pm 30\%$ of the initial measured value						
	Internal resistance	Within four times of the initial specified value						
Shelf life (85°C)	Test time : 1000 hours ; Same as endurance.							
Applicable standards	Conforms to JIS C5160-1 2009 (IEC 62391-1 2006)							

Outline Drawing

Unit : mm

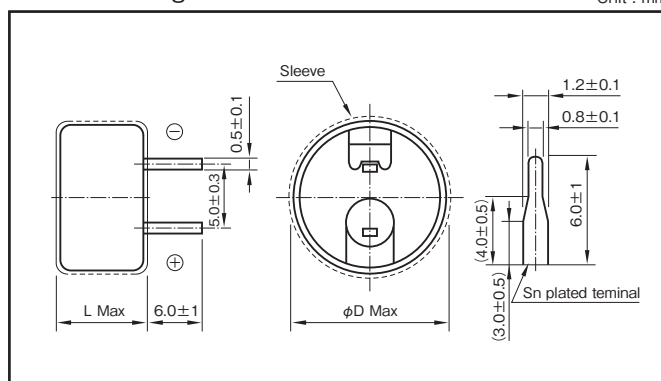

Part numbering system (example : 3.6V0.1F)

DBS	—	3R6	D	104	\square	T
Series code		Rated voltage symbol	Terminal code	Rated capacitance symbol		Additional symbol

Part number is refer to following table.

Standard Ratings

Max. operating voltage (V)	Rated capacitance (F)	ELNA Parts No.	$\phi D \times L$ (mm)
3.6	0.047	DBS-3R6D473T	13.5 × 7.5
3.6	0.1	DBS-3R6D104T	13.5 × 7.5
3.6	0.22	DBS-3R6D224T	13.5 × 7.5
3.6	0.33	DBS-3R6D334T	13.5 × 7.5
3.6	0.47	DBS-3R6D474ST	13.5 × 7.5
3.6	0.47	DBS-3R6D474T	21.5 × 8.0
3.6	1.0	DBS-3R6D105T	21.5 × 8.0

NOTE

Design, Specifications are subject to change without notice. Ask factory for technical specifications before purchase and/or use.

5.5V Miniaturized Standard Capacitors

GREEN CAP

70°C

- Smaller and lighter than Series DB.
- 5mm tall. Max. thin profile (H-shaped).
- Miniaturized but can encase up to 0.47F in 11.5×5mm case, and 1.5F in 19.0×20.5mm case.

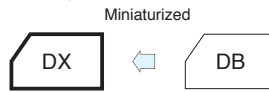

Marking color : White print on an indigo sleeve

Specifications

Item	Performance	
Category temperature range (°C)	-25 to +70	
Tolerance at rated capacitance (%)	-20 to +80	
Internal resistance at 1 kHz	Rated capacitance (F)	0.047 0.1 0.22 0.33 0.47 0.47 1.0 1.5
	Internal resistance (Ω)	120 75 75 75 75 (φ11.5) 30 (φ19.0) 30 30
Characteristics at high and low temperature	Percentage of capacitance change	Within ±30% of the value at 20°C
	Internal resistance	Less than five times of the value at 20°C
Endurance (70°C)	Test time	1000 hours
	Percentage of capacitance change	Within ±30% of the initial measured value
	Internal resistance	Less than four times of the initial specified value
Shelf life (70°C)	Test time : 1000 hours ; Same as endurance.	
Applicable standards	Conforms to JIS C5160-1 2009 (IEC 62391-1 2006)	

Outline Drawing

Unit : mm

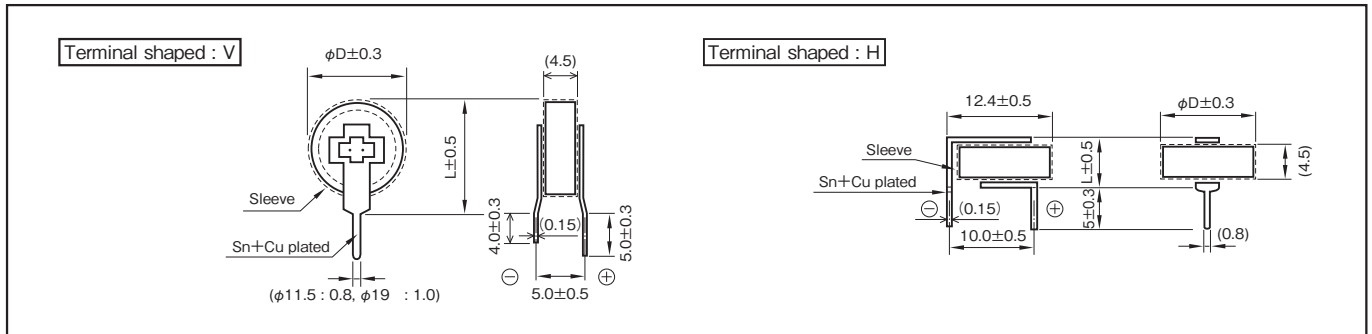

Part numbering system (example : 5.5V0.1F)						
DX	—	5R5	□	104	□	U
Series code		Rated voltage symbol	Terminal code	Rated capacitance symbol	Additional symbol	

Note

Do not apply external force to products or terminals as stress such as twisting, bending, pushing, or falling of such products or terminals may remove the terminals, resulting in an open/short circuit or liquid leakage. Avoid applying excessive heat to capacitors during heating of an adhesive curing oven. For details, refer to the precautions in use of DYNACAP.

Part number is refer to below table.

Standard Ratings

Max. operating voltage (V)	Rated capacitance (F)	ELNA Parts No.	φD×L (mm)
5.5	0.047	DX-5R5V473U	11.5×13.0
		DX-5R5H473U	11.5× 5.0
5.5	0.1	DX-5R5V104U	11.5×13.0
		DX-5R5H104U	11.5× 5.0
5.5	0.22	DX-5R5V224U	11.5×13.0
		DX-5R5H224U	11.5× 5.0
5.5	0.33	DX-5R5V334U	11.5×13.0
		DX-5R5H334U	11.5× 5.0
5.5	0.47	DX-5R5V474SU	11.5×13.0
		DX-5R5H474SU	11.5× 5.0
		DX-5R5V474U	19.0×20.5
5.5	1.0	DX-5R5V105U	19.0×20.5
5.5	1.5	DX-5R5V155U	19.0×20.5

NOTE

Design, Specifications are subject to change without notice. Ask factory for technical specifications before purchase and/or use.

5.5V Miniaturized Low Resistance

GREEN CAP

70°C

- Internal resistance was reduced to 85% to DX series and this size.
- 5mm tall. Max. thin profile (H-shaped).
- Miniaturized but can encase up to 0.47F in 11.5×5mm case, and 1.5F in 19.0×20.5mm case.
- It excels in rapid charge.
(It can charge and discharge with 1.5 times as much current (mA) as rated capacitance.)



Marking color : White print on an indigo sleeve

Specifications

Item	Performance								
Category temperature range (°C)	-25 to +70								
Tolerance at rated capacitance (%)	-20 to +80								
Internal resistance at 1 kHz	Rated capacitance (F)	0.047	0.1	0.22	0.33	0.47	0.47	1.0	1.5
	Internal resistance (Ω)	25	25	25	25	25 (φ11.5)	20 (φ19.0)	20	20
Characteristics at high and low temperature	Percentage of capacitance change	Within ±30% of the value at 20°C							
	Internal resistance	Less than five times of the value at 20°C							
Endurance (70°C)	Test time	1000 hours							
	Percentage of capacitance change	Within ±30% of the initial measured value							
	Internal resistance	Less than four times of the initial specified value							
Shelf life (70°C)	Test time : 1000 hours ; Same as endurance.								
Applicable standards	Conforms to JIS C5160-1 2009(IEC 62391-1 2006)								

Outline Drawing

Unit : mm

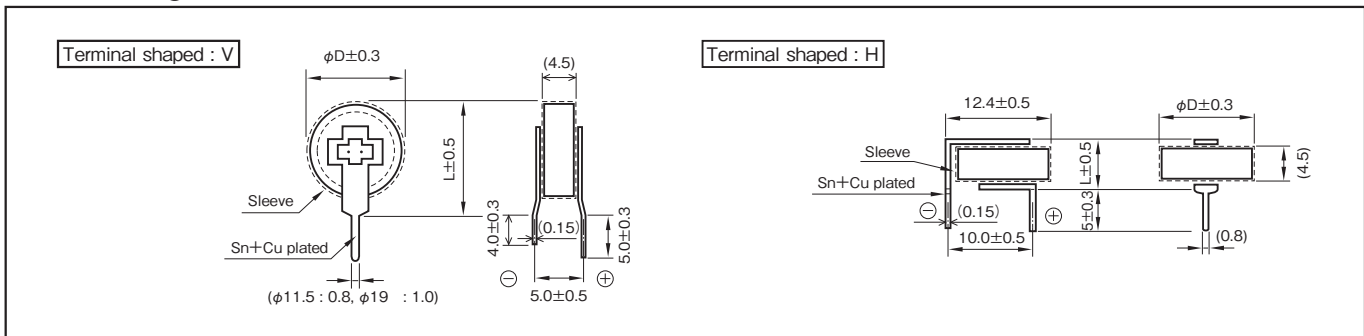

Part numbering system (example : 5.5V0.1F)

DXN	—	5R5	□	104	□	U
Series code		Rated voltage symbol	Terminal shaped	Rated Capacitance symbol	Additional symbol	

Part number is refer to below table.

Note

Do not apply external force to products or terminals as stress such as twisting, bending, pushing, or falling of such products or terminals may remove the terminals, resulting in an open/short circuit or liquid leakage. Avoid applying excessive heat to capacitors during heating of an adhesive curing oven. For details, refer to the precautions in use of DYNACAP.

Standard Ratings

Max. operating voltage (V)	Rated capacitance (F)	ELNA Parts No.	φD×L (mm)
5.5	0.047	DXN-5R5V473U	11.5×13.0
		DXN-5R5H473U	11.5× 5.0
5.5	0.1	DXN-5R5V104U	11.5×13.0
		DXN-5R5H104U	11.5× 5.0
5.5	0.22	DXN-5R5V224U	11.5×13.0
		DXN-5R5H224U	11.5× 5.0
5.5	0.33	DXN-5R5V334U	11.5×13.0
		DXN-5R5H334U	11.5× 5.0
5.5	0.47	DXN-5R5V474SU	11.5×13.0
		DXN-5R5H474SU	11.5× 5.0
		DXN-5R5V474U	19.0×20.5
5.5	1.0	DXN-5R5V105U	19.0×20.5
5.5	1.5	DXN-5R5V155U	19.0×20.5

NOTE

Design, Specifications are subject to change without notice. Ask factory for technical specifications before purchase and/or use.

5.5V Miniaturized High temperature Capacitors

GREEN CAP 85°C

- High temperature type of Series DX.
- 5mm tall. Max. thin profile (H-shaped).
- Miniaturized but can encase up to 0.33F in 11.5×5mm case, and 1.0F in 19.0×20.5mm case.

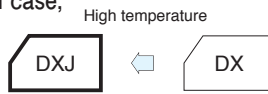

Marking color : White print on a black sleeve

Specifications

Item	Performance					
Category temperature range (°C)	-10 to +85					
Tolerance at rated capacitance (%)	-20 to +80					
Internal resistance at 1 kHz	Rated capacitance (F)	0.047	0.1	0.22	0.33	1.0
	Internal resistance (Ω)	200	150	150	150	75
Characteristics at high and low temperature	Percentage of capacitance change	Within ±30% of the value at 20°C				
	Internal resistance	Within four times of the initial specified value				
Endurance (85°C)	Test time	1000 hours				
	Percentage of capacitance change	Within ±30% of the initial measured value				
	Internal resistance	Less than four times of the initial specified value				
Shelf life (85°C)	Test time : 1000 hours ; Same as endurance.					
Applicable standards	Conforms to JIS C5160-1 2009 (IEC 62391-1 2006)					

Outline Drawing

Unit : mm

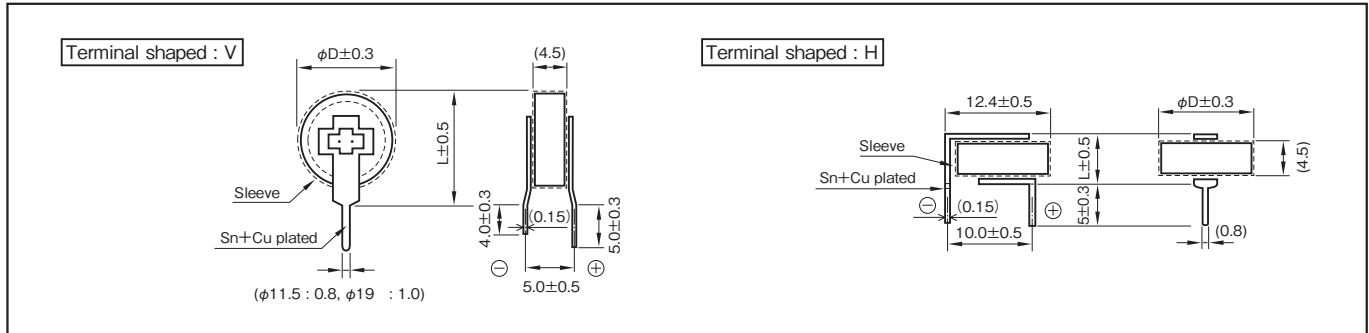

Part numbering system (example : 5.5V0.1F)				
DXJ	—	5R5	□	104 U
Series code		Rated voltage symbol	Terminal shaped	Rated Capacitance symbol

Part number is refer to below table.

Note

Do not apply external force to products or terminals as stress such as twisting, bending, pushing, or falling of such products or terminals may remove the terminals, resulting in an open/short circuit or liquid leakage. Avoid applying excessive heat to capacitors during heating of an adhesive curing oven. For details, refer to the precautions in use of DYNACAP.

Standard Ratings

Max. operating voltage (V)	Rated capacitance (F)	ELNA Parts No.	φD×L (mm)
5.5	0.047	DXJ-5R5V473U	11.5×13.0
		DXJ-5R5H473U	11.5× 5.0
5.5	0.1	DXJ-5R5V104U	11.5×13.0
		DXJ-5R5H104U	11.5× 5.0
5.5	0.22	DXJ-5R5V224U	11.5×13.0
		DXJ-5R5H224U	11.5× 5.0
5.5	0.33	DXJ-5R5V334U	11.5×13.0
		DXJ-5R5H334U	11.5× 5.0
5.5	1.0	DXJ-5R5V105U	19.0×20.5

NOTE

Design, Specifications are subject to change without notice. Ask factory for technical specifications before purchase and/or use.

3.6V Miniaturized Low ESR High Temperature GREEN CAP 85°C

- Long life of 3.6V 2000 hours, low ESR in DX series and this size.
- 5mm tall. Max. thin profile (H-shaped).
- Wider temperature range (-25 to +85°C) than battery.
- Miniaturized but can encase up to 0.47F in 11.5×5mm case and 1.0F in 19.0×20.5mm case.
- It excels in rapid charge.

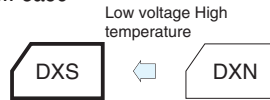

Marking color : White print on a black sleeve

Specifications

Item	Performance	
Category temperature range (°C)	-25 to +85	
Tolerance at rated capacitance (%)	-20 to +80	
Internal resistance at 1 kHz	Rated capacitance (F)	0.047 0.1 0.22 0.33 0.47 0.47 1.0
	Internal resistance (Ω)	25 25 25 25 25 (φ 11.5) 20 (φ 19.0) 20
Characteristics at high and low temperature	Percentage of capacitance change	Within ±30% of the value at 20°C
	Internal resistance	Less than five times of the value at 20°C
Endurance (85°C)	Test time	2000 hours (φ 11.5 0.047F : 1000 hours)
	Percentage of capacitance change	Within ±30% of the initial measured value
	Internal resistance	Less than four times of the initial specified value
Shelf life (85°C)	Test time : 1000 hours ; Same as endurance.	
Applicable standards	Conforms to JIS C5160-1 2009(IEC 62391-1 2006)	

Outline Drawing

Unit : mm

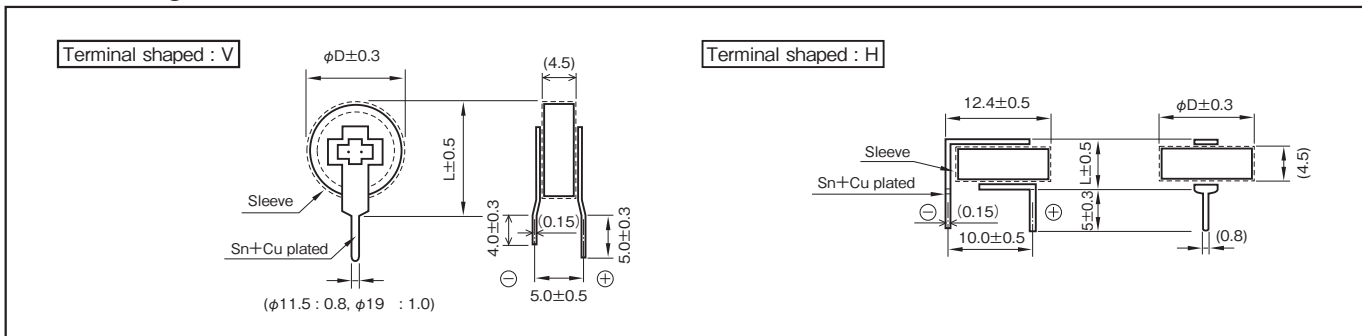

Part numbering system (example : 3.6V0.1F)						
DXS	—	3R6	□	104	□	U
Series code		Rated voltage symbol	Terminal shaped	Rated capacitance symbol	Additional symbol	

Part number is refer to below table.

Note

Do not apply external force to products or terminals as stress such as twisting, bending, pushing, or falling of such products or terminals may remove the terminals, resulting in an open/short circuit or liquid leakage. Avoid applying excessive heat to capacitors during heating of an adhesive curing oven. For details, refer to the precautions in use of DYNACAP.

Standard Ratings

Max. operating voltage (V)	Rated capacitance (F)	ELNA Parts No.	φD×L (mm)
3.6	0.047	DXS-3R6V473U	11.5×13.0
		DXS-3R6H473U	11.5× 5.0
3.6	0.1	DXS-3R6V104U	11.5×13.0
		DXS-3R6H104U	11.5× 5.0
3.6	0.22	DXS-3R6V224U	11.5×13.0
		DXS-3R6H224U	11.5× 5.0
3.6	0.33	DXS-3R6V334U	11.5×13.0
		DXS-3R6H334U	11.5× 5.0
3.6	0.47	DXS-3R6V474SU	11.5×13.0
		DXS-3R6H474SU	11.5× 5.0
		DXS-3R6V474U	19.0×20.5
3.6	1.0	DXS-3R6V105U	19.0×20.5

Electric Double Layer Capacitors

NOTE

Design, Specifications are subject to change without notice. Ask factory for technical specifications before purchase and/or use.

High Voltage Tolerance Capacitors

GREEN CAP

70°C

- High voltage tolerant (6.3V guaranteed) and highly reliable.
- Ideal for backing up of Li-battery-backed equipment such as cameras, video and telephone sets.

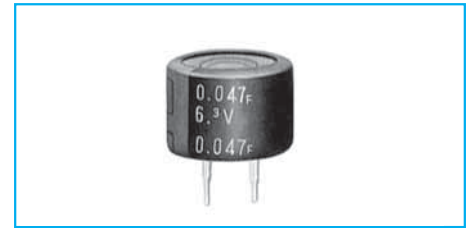
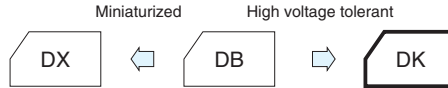

Marking color : White print on an indigo sleeve

Specifications

Item	Performance					
Category temperature range (°C)	-25 to +70					
Tolerance at rated capacitance (%)	-20 to +80					
Internal resistance at 1 kHz	Rated capacitance (F)	0.047	0.1	0.47	0.68	1.0
	Internal resistance (Ω)	300	200	50	50	30
Characteristics at high and low temperature	Percentage of capacitance change	Within ±30% of the value at 20°C				
	Internal resistance	less than five times of the value at 20°C				
Endurance (70°C)	Test time	1000 hours				
	Percentage of capacitance change	Within ±30% of the initial measured value				
	Internal resistance	Less than four times of the initial specified value				
Shelf life (70°C)	Test time : 1000 hours ; Same as endurance.					
Applicable standards	Conforms to JIS C5160-1 2009 (IEC 62391-1 2006)					

Outline Drawing

Unit : mm

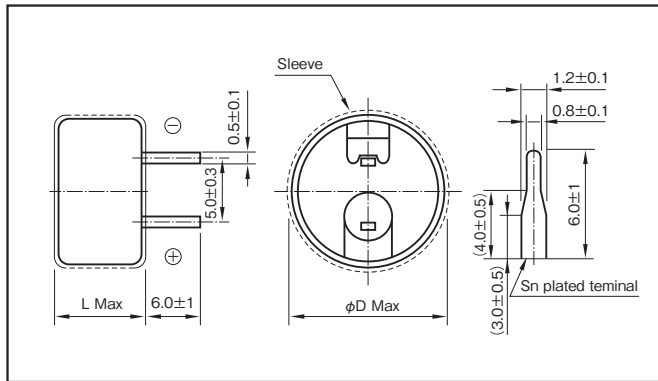

Part numbering system (example : 6.3V0.1F)

DK	—	6R3	D	104	T
Series code		Max.operating voltage symbol		Rated capacitance symbol	

Part number is refer to below table.

Standard Ratings

Max. operating voltage (V)	Rated capacitance (F)	ELNA Parts No.	φD×L (mm)
6.3	0.047	DK-6R3D473T	13.5×9.5
6.3	0.1	DK-6R3D104T	13.5×9.5
6.3	0.47	DK-6R3D474T	21.5×9.5
6.3	0.68	DK-6R3D684T	21.5×9.5
6.3	1.0	DK-6R3D105T	21.5×9.5

NOTE

Design, Specifications are subject to change without notice.
Ask factory for technical specifications before purchase and/or use.

High-Temperature Capacitors

GREEN CAP 85°C

- High temperature tolerant (−25 to +85°C) and highly reliable.
- Ideal for backing up of controls, electronic rice cooking jars, home bakeries and the like.

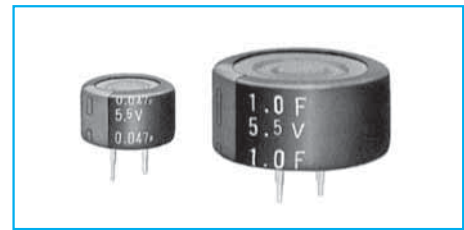
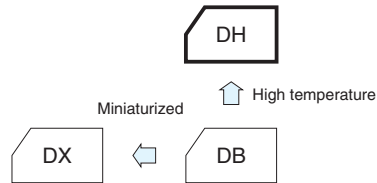

Marking color : White print on an indigo sleeve

Specifications

Item	Performance							
Category temperature range (°C)	−25 to +85							
Tolerance at rated capacitance (%)	−20 to +80							
Internal resistance at 1 kHz	Rated capacitance (F)	0.047	0.1	0.22	0.47	0.68	1.0	
	Internal resistance (Ω)	300	200	120	50	50	30	
Characteristics at high and low temperature	Percentage of capacitance change	Within ±30% of the value at 20°C						
	Internal resistance	less than five times of the value at 20°C						
Endurance (85°C)	Test time	1000 hours						
	Percentage of capacitance change	Within ±30% of the initial measured value						
	Internal resistance	Less than four times of the initial specified value						
Shelf life (85°C)	Test time : 1000 hours ; Same as endurance.							
Applicable standards	Conforms to JIS C5160-1 2009 (IEC 62391-1 2006)							

Outline Drawing

Unit : mm

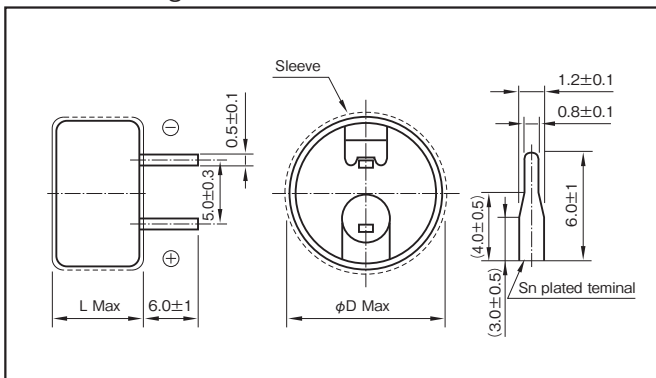

Part numbering system (example : 5.5V0.1F)

DH	—	5R5	D	104	T
Series code		Max.operating voltage symbol		Rated capacitance symbol	

Part number is refer to below table.

Standard Ratings

Max. operating voltage (V)	Rated capacitance (F)	ELNA Parts No.	φD×L (mm)
5.5	0.047	DH-5R5D473T	13.5×9.5
5.5	0.1	DH-5R5D104T	13.5×9.5
5.5	0.22	DH-5R5D224T	13.5×9.5
5.5	0.47	DH-5R5D474T	21.5×9.5
5.5	0.68	DH-5R5D684T	21.5×9.5
5.5	1.0	DH-5R5D105T	21.5×9.5

NOTE

Design, Specifications are subject to change without notice. Ask factory for technical specifications before purchase and/or use.

5.5V Wide Temperature Range Capacitors GREEN CAP 85°C

- It is a category temperature range larger than battery.
- $\phi 13.5$ size can encase up to 0.22F, $\phi 21.5$ size can encase up to 1.0F.
- It excels in rapid charge.
- Ideal for backing up of CMOS IC's, microcomputers, RAM's, RTC's for smart meter, outdoor equipment, auto motive and industrial.

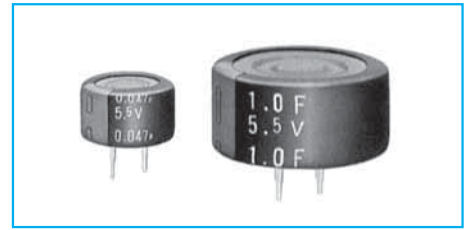
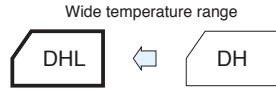

Marking color : White print on an indigo sleeve

Specifications

Item	Performance						
Category temperature range (°C)	-40 to +85						
Tolerance at rated capacitance (%)	-20 to +80						
Internal resistance at 1 kHz	Rated capacitance (F)	0.047	0.1	0.22	0.47	0.68	1.0
	Internal resistance (Ω)	40	40	40	20	20	20
Characteristics at high and low temperature	Percentage of capacitance change	Within $\pm 30\%$ of the value at 20°C					
	Internal resistance	-40°C : Less than seven times of the value at 20°C 85°C : Less than five times of the value at 20°C					
Endurance (85°C)	Test time	1000 hours					
	Percentage of capacitance change	Within $\pm 30\%$ of the initial measured value					
	Internal resistance	Less than four times of the initial specified value					
Shelf life (85°C)	Test time : 1000 hours ; Same as endurance.						
Applicable standards	Conforms to JIS C5160-1 2009 (IEC 62391-1 2006)						

Outline Drawing

Unit : mm

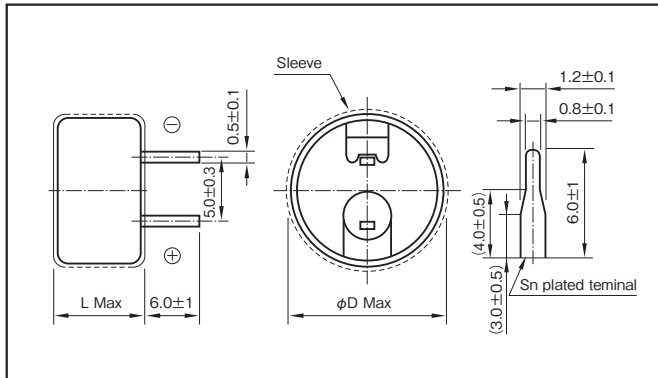

Part numbering system (example : 6.3V0.1F)

DHL	—	5R5	D	104	T
Series code		Rated voltage symbol	Terminal code	Rated capacitance symbol	

Part number is refer to below table.

Standard Ratings

Max. operating voltage (V)	Rated capacitance (F)	ELNA Parts No.	$\phi D \times L$ (mm)
5.5	0.047	DHL-5R5D473T	13.5×9.5
5.5	0.1	DHL-5R5D104T	13.5×9.5
5.5	0.22	DHL-5R5D224T	13.5×9.5
5.5	0.47	DHL-5R5D474T	21.5×9.5
5.5	0.68	DHL-5R5D684T	21.5×9.5
5.5	1.0	DHL-5R5D105T	21.5×9.5

5.5V High Temperature, Long Life Capacitors

GREEN CAP

85°C

- Guarantees 3000 hours at 85°C, 5.5V (10 years at room temperature).
- It is a category temperature range larger than battery.
- It excels in rapid charge.
- Ideal for backing up of CMOS IC's, microcomputers, RAM's, RTC's for smart meter, outdoor equipment, auto motive and industrial.

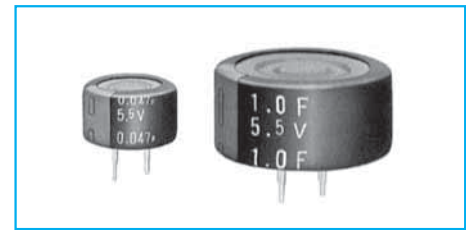

Marking color : White print on a Black sleeve

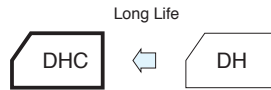

Specifications

Item	Performance							
Category temperature range (°C)	-25 to +85							
Tolerance at rated capacitance (%)	-20 to +80							
Internal resistance at 1 kHz	Rated capacitance (F)	0.047	0.1	0.22	0.47	0.68	1.0	
	Internal resistance (Ω)	300	200	120	50	50	30	
Characteristics at high and low temperature	Percentage of capacitance change	Within ±30% of the value at 20°C						
	Internal resistance	less than five times of the value at 20°C						
Endurance (85°C)	Test time	3000 hours						
	Percentage of capacitance change	Within ±30% of the initial measured value						
	Internal resistance	Less than four times of the initial specified value						
Shelf life (85°C)	Test time : 1000 hours ; Same as endurance.							
Applicable standards	Conforms to JIS C5160-1 2009 (IEC 62391-1 2006)							

Outline Drawing

Unit : mm

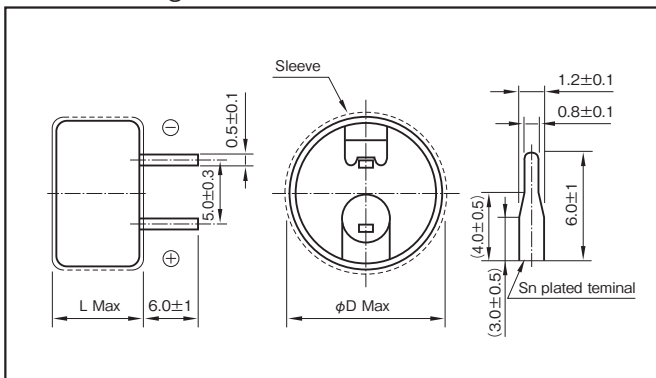

Part numbering system (example : 5.5V0.1F)

DHC	—	5R5	D	104	T
Series code		Rated voltage symbol	Terminal code	Rated capacitance symbol	

Part number is refer to below table.

Standard Ratings

Max. operating voltage (V)	Rated capacitance (F)	ELNA Parts No.	φD×L (mm)
5.5	0.047	DHC-5R5D473T	13.5×9.5
5.5	0.1	DHC-5R5D104T	13.5×9.5
5.5	0.22	DHC-5R5D224T	13.5×9.5
5.5	0.47	DHC-5R5D474T	21.5×9.5
5.5	0.68	DHC-5R5D684T	21.5×9.5
5.5	1.0	DHC-5R5D105T	21.5×9.5

NOTE

Design, Specifications are subject to change without notice. Ask factory for technical specifications before purchase and/or use.

Coin Cell Capacitors



- Unlike batteries, the number of charging / discharging cycles unlimited and rapid charging / discharging is possible.
- High reliability, Safe and unlike secondary batteries, this is pollution free devices.
- 1.8mm height 614type made lineup in the DC, DCK Series.

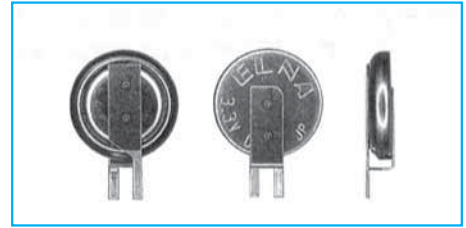
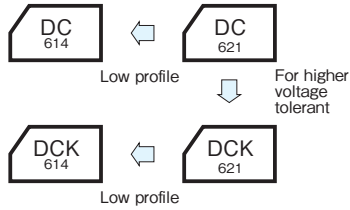

Specifications

Item	Performance					
Series Name	Series DC			Series DCK		
Max. operating voltage (V)	2.5			3.3		
Category temperature range (°C)	-25 to +70			-10 to +60		
Tolerance at rated capacitance (%)	-20 to +80			-20 to +80		
Internal resistance (Ω) at 1 kHz	Size code	614	621	Size code	614	621
	Rated capacitance (F)	0.2	0.4	Rated capacitance (F)	0.2	0.4
	Internal resistance (Ω)	100	100	Internal resistance (Ω)	200	200
Characteristics at high and low temperature	Size code	614	621	Size code	614	621
	Rated capacitance (F)	Within ±30% of the value at 20°C	Within ±30% of the value at 20°C	Rated capacitance (F)	Within ±50% of the value at 20°C	Within ±50% of the value at 20°C
	Internal resistance (Ω)	Less than five times of the value at 20°C	Less than five times of the value at 20°C	Internal resistance (Ω)	Less than five times the initial specified value	Less than ten times of the value at 20°C
Endurance	Size code	614	621	Size code	614	621
	Test time and temp	70°C 1000 hours	70°C 500 hours	Test time and temp	60°C 1000 hours	60°C 500 hours
	Rated capacitance (F)	Within ±30% of the initial measured value	of the initial measured value	Rated capacitance (F)	Within ±30% of the initial measured value	Within ±40% of the initial measured value
	Internal resistance (Ω)	1kΩ Max.	400Ω Max.	Internal resistance (Ω)	2kΩ Max.	800Ω Max.
Shelf life	Same as endurance.			Same as endurance.		
Applicable standards	Conforms to JIS C5160-1 2009 (IEC 62391-1 2006)					

Outline Drawing

Unit : mm

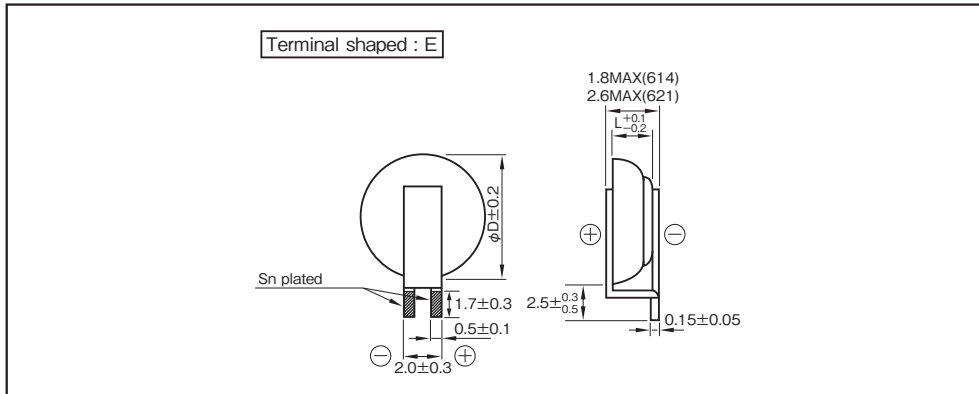

Part numbering system (example : 614, 2.5V0.2F, terminal shaped : E)

DC	—	2R5	E	204	T 614	—	E
Series code		Max. operating voltage symbol		Rated capacitance symbol	Additional symbol		

Part number is refer to below table.

Part numbering system (example : 621, 3.3V0.4F, terminal shaped : E)

DCK	—	3R3	E	404	T	—	E
Series code		Max. operating voltage symbol		Rated capacitance symbol	Additional symbol		

Part number is refer to below table.

Standard Ratings

Max. operating voltage (V)	Rated capacitance (F)	ELNA Parts No.	φD×L (mm)
2.5	0.2	DC-2R5E204T614-E	6.8×1.4
3.3	0.2	DCK-3R3E204T614-E	6.8×1.4
2.5	0.4	DC-2R5E404T-E	6.8×2.1
3.3	0.4	DCK-3R3E404T-E	6.8×2.1

NOTE

Design, Specifications are subject to change without notice. Ask factory for technical specifications before purchase and/or use.

Coin Cell Capacitors

GREEN CAP

70°C

- Reflow soldering method available.
- Unlike batteries, the number of charging / discharging cycles unlimited and rapid charging / discharging is possible.
- Unlike batteries, excellent charge and discharge characteristics with no chemical reactions.
- $\phi 4.8 \times 1.71$ mm Max height type made lineup in the DSK series.

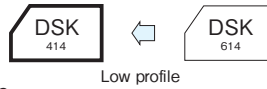

Specifications

Item	Performance	
Series Name	DSK series	
Max. operating voltage (V)	3.3	
Category temperature range (°C)	-10 to +70	
Tolerance at rated capacitance (%)	-20 to +80	
Rated Capacitance (F)	0.07	
Internal resistance (Ω) at 1 kHz	100	
Characteristics at high and low temperature	Percentage of capacitance change	Within $\pm 50\%$ of the value at 20°C
	Internal resistance	Within ten times the initial specified value
Endurance	Test temperature	70°C
	Test time	500 hours
	Percentage of capacitance change	Within $\pm 30\%$ of the initial measured value
	Internal resistance	5k Ω or less
Shelf life	Test time : 500 hours ; Same as endurance.	
Applicable standards	Conforms to JIS C5160-1 2009 (IEC 62391-1 2006)	

Outline Drawing

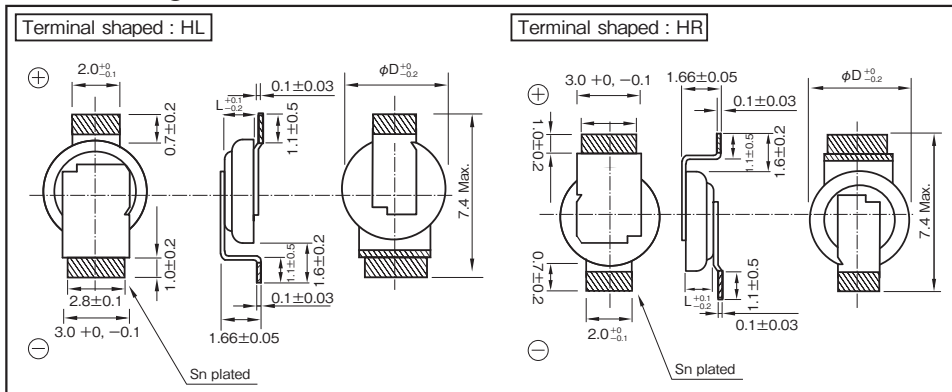

Unit : mm

Recommended land pattern size Unit : mm

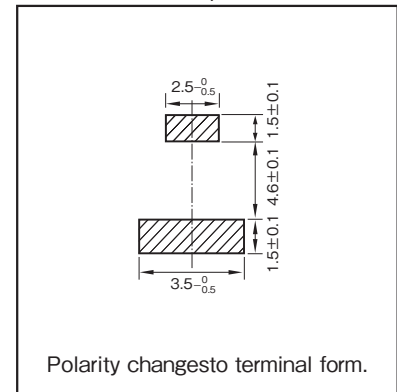

Polarity changes to terminal form.

*Please consult with us about other terminal form

Part numbering system (3.3V0.07F, terminal shaped : HL)

DSK	—	3R3	H	703	T414	—	HL	L
Series code		Max. operating voltage symbol		Rated capacitance symbol	Additional symbol		Terminal shaped	Taping

Standard Ratings

Max. operating voltage (V)	Rated capacitance (F)	ELNA Parts No.	$\phi D \times L$ (mm)
3.3	0.07	DSK-3R3H703T414-HLL	4.8×1.4
		DSK-3R3H703T414-HRL	

*Reflow soldering condition : 181 page.

NOTE

Design, Specifications are subject to change without notice. Ask factory for technical specifications before purchase and/or use.

Coin Cell Capacitors



- Reflow soldering method available.
- Unlike batteries, the number of charging/ discharging cycles unlimited and rapid charging/ discharging is possible.
- Unlike batteries, excellent charge and discharge characteristics with no chemical reactions.
- 1.8mm height type 614 made lineup in the DS, DSK series.

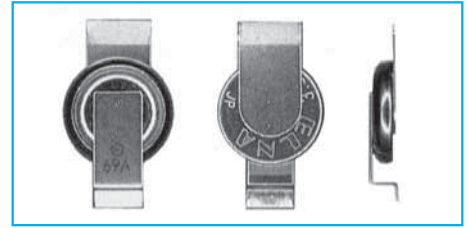
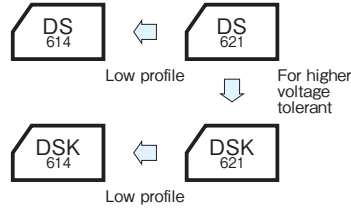

Specifications

Item	Performance					
	Series DS			Series DSK		
Series Name	Series DS			Series DSK		
Max.operating voltage (V)	2.5			3.3		
Category temperature range (°C)	-25 to +70			-10 to +60		
Tolerance at rated capacitance (%)	-20 to +80			-20 to +80		
Internal resistance (Ω) at 1 kHz	Size code	614	621	Size code	614	621
	Rated capacitance (F)	0.2	0.33	Rated capacitance (F)	0.2	0.33
	Internal resistance (Ω)	100	100	Internal resistance (Ω)	200	200
Characteristics at high and low temperature	Size code	614	621	Size code	614	621
	Rated capacitance (F)	Within ±30% of the value at 20°C	Within ±30% of the value at 20°C	Rated capacitance (F)	Within ±50% of the value at 20°C	Within ±50% of the value at 20°C
	Internal resistance (Ω)	Less than five times of the value at 20°C	Less than five times of the value at 20°C	Internal resistance (Ω)	Less than five times the initial specified value	Less than five times of the value at 20°C
Endurance	Size code	614	621	Size code	614	621
	Test time and temp.	70°C 1000 hours	70°C 500 hours	Test time and temp.	60°C 1000 hours	60°C 500 hours
	Rated capacitance (F)	Within ±30% of the initial measured value	Within ±30% of the initial measured value	Rated capacitance (F)	Within ±30% of the initial measured value	Within ±30% of the initial measured value
	Internal resistance (Ω)	1kΩ Max.	400Ω Max.	Internal resistance (Ω)	2kΩ Max.	800Ω Max.
Shelf life	Same as endurance.			Same as endurance.		
Applicable standards	Conforms to JIS C5160-1 2009(IEC 62391-1 2006)					

Outline Drawing

Unit : mm

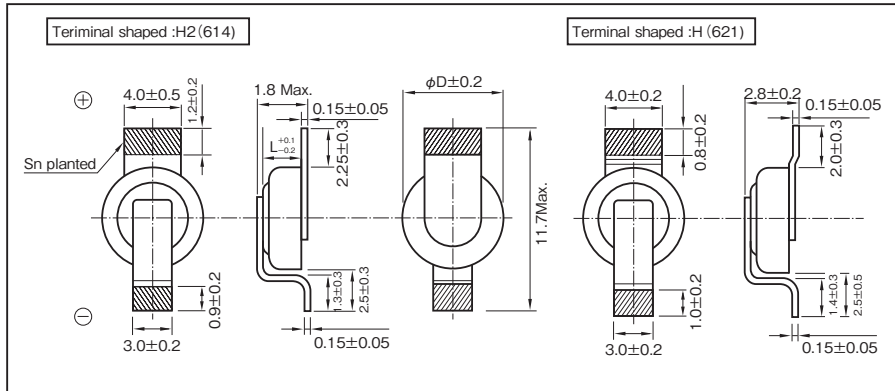

Recommended land pattern size

Unit : mm

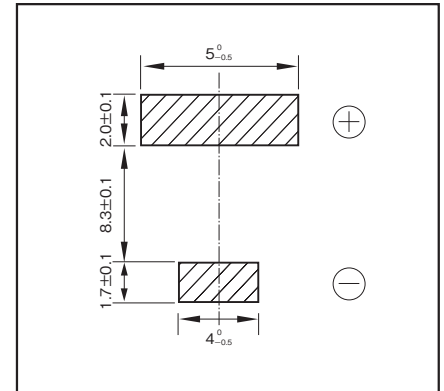

*Please consult with us about other terminal form.

Part numbering system (2.5V0.2F, terminal shaped:H2)						
DS	—	2R5	H	204	T614	— H2 L
Series code	Max.operating voltage symbol	Rated capacitance symbol	Additional symbol	Terminal shaped	Taping	

Part number is refer to below table.

Part numbering system (example:621, 3.3V0.33F, terminal shaped:H)						
DSK	—	3R3	H	334	T	— H L
Series code	Max.operating voltage symbol	ated capacitance symbol	Additional symbol	Terminal shaped	Taping	

Part number is refer to below table.

Standard Ratings

Max. operating voltage (V)	Rated capacitance (F)	ELNA Parts No.	φD×L (mm)
2.5	0.20	DS-2R5H204T614-H2L	6.8×1.4
3.3	0.20	DSK-3R3H204T614-H2L	6.8×1.4
2.5	0.33	DS-2R5H334T-HL	6.8×2.1
3.3	0.33	DSK-3R3H334T-HL	6.8×2.1

* Reflow soldering condition : 181 page.

NOTE

Design, Specifications are subject to change without notice. Ask factory for technical specifications before purchase and/or use.

Standard, Large capacitance type Capacitors

GREEN CAP 60°C / 70°C 2.5V / 2.7V

- Pollution-Free ; with no pollutants such as Cd or Pb.
- Unlike batteries ; excellent charge and discharge characteristics with no chemical reactions

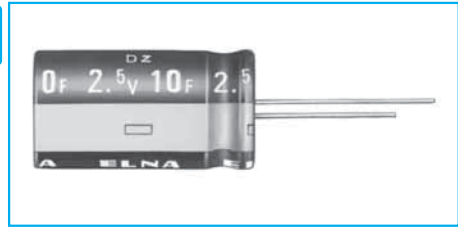
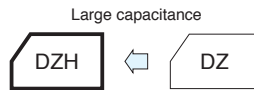

Marking color : White print on a black sleeve

Specifications

Item	Performance	
Series name	Series DZ	Series DZH
Category temperature range (°C)	-25 to +70	-25 to +60
Tolerance at rated capacitance (%)	-20 to +80	-20 to +80
Internal resistance at 1kHz	Refer to the following page	
Characteristics at high and low temperature	Percentage of capacitance change	Within ±30% of the value at 20°C
	Internal resistance	Less than five times of the value at 20°C
Endurance	Test temperature	70°C
	Test time	1000 hours
	Percentage of capacitance change	Within ±30% of the initial measured value
	Internal resistance	Less than four times of the initial specified value
Shelf life	Same as endurance	
Applicable standards	Conforms to JIS C5160-1 2009 (IEC 62391-1 2006)	

Outline Drawing

Unit : mm

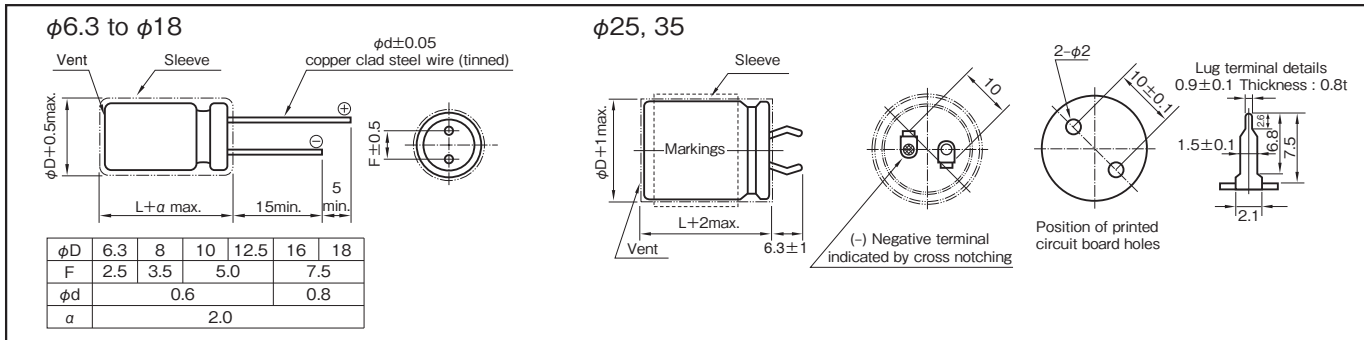

Part numbering system (example : 2.5V10F)

DZ	—	2R5	D	106	(H8)	T
Series code		Rated voltage symbol	Terminal code	Rated capacitance symbol	Casing symbol	

Part number is refer to the following page.

NOTE

Design, Specifications are subject to change without notice. Ask factory for technical specifications before purchase and/or use.

Standard Ratings (Series DZ 2.5V)

Max. operating voltage (V)	Rated capacitance (F)	Max. Leakage Current (mA) after 24h	ELNA Parts No.	φ D×L (mm)	Internal resistance (Ω max.) at 1kHz	Internal resistance (mΩ) at 1kHz (measurement value)
2.5	0.9	0.1	DZ-2R5D904F4T	6.3×14.0	1.0	400
2.5	1.0	0.1	DZ-2R5D105G3T	8.0×12.0	1.0	200
2.5	1.0	0.1	DZ-2R5D105G4T	8.0×15.0	1.0	200
2.5	1.0	0.1	DZ-2R5D105T	8.0×22.0	1.0	150
2.5	2.7	0.2	DZ-2R5D275G5T	8.0×22.0	0.5	150
2.5	3.3	0.2	DZ-2R5D335H5T	10.0×20.0	0.3	70
2.5	3.3	0.2	DZ-2R5D335T	12.5×23.0	0.3	70
2.5	4.7	0.3	DZ-2R5D475H5T	10.0×20.0	0.2	80
2.5	4.7	0.3	DZ-2R5D475T	12.5×31.5	0.2	40
2.5	6.8	0.4	DZ-2R5D685H7T	10.0×30.0	0.2	50
2.5	10	0.5	DZ-2R5D106H8T	10.0×35.0	0.2	40
2.5	10	0.5	DZ-2R5D106Z7T	12.5×31.5	0.2	40
2.5	10	0.5	DZ-2R5D106T	18.0×35.0	0.2	30
2.5	15	0.7	DZ-2R5D156J5T	16.0×20.0	0.2	35
2.5	20	0.8	DZ-2R5D206K8T	18.0×35.0	0.2	30
2.5	20	0.8	DZ-2R5D206T	18.0×40.0	0.2	30
2.5	22	0.8	DZ-2R5D226J6T	16.0×25.0	0.2	30
2.5	30	0.8	DZ-2R5D306K9T	18.0×40.0	0.2	30
2.5	33	0.8	DZ-2R5D336J8T	16.0×35.5	0.2	30
2.5	50	1.0	DZ-2R5D506T	25.0×40.0	0.08	20
2.5	100	1.0	DZ-2R5D107S37T	25.0×50.0	0.08	15
2.5	100	1.0	DZ-2R5D107T	35.0×50.0	0.08	15
2.5	200	2.0	DZ-2R5D207S57T	35.0×50.0	0.08	15

We tailor packaged product in series and parallel arrangements according to voltage and capacitance as required.

Standard Ratings (Series DZ 2.7V)

Max. operating voltage (V)	Rated capacitance (F)	Max. Leakage Current (mA) after 24h	ELNA Parts No.	φ D×L (mm)	Internal resistance (Ω max.) at 1kHz	Internal resistance (mΩ) at 1kHz (measurement value)
2.7	0.9	0.2	DZ-2R7D904F4T	6.3×14.0	1.0	400
2.7	1.0	0.2	DZ-2R7D105G3T	8.0×12.0	1.0	200
2.7	1.0	0.2	DZ-2R7D105G4T	8.0×15.0	1.0	200
2.7	1.0	0.2	DZ-2R7D105G5T	8.0×22.0	1.0	150
2.7	2.7	0.3	DZ-2R7D275G5T	8.0×22.0	0.5	150
2.7	3.3	0.3	DZ-2R7D335H5T	10.0×20.0	0.3	100
2.7	3.3	0.3	DZ-2R7D335Z6T	12.5×23.0	0.3	70
2.7	4.7	0.4	DZ-2R7D475H5T	10.0×20.0	0.2	80
2.7	4.7	0.4	DZ-2R7D475Z7T	12.5×31.5	0.2	40
2.7	6.8	0.5	DZ-2R7D685H7T	10.0×30.0	0.2	50
2.7	10	0.6	DZ-2R7D106H8T	10.0×35.0	0.2	40
2.7	10	0.6	DZ-2R7D106Z7T	12.5×31.5	0.2	40
2.7	10	0.6	DZ-2R7D106K8T	18.0×35.0	0.2	30
2.7	15	0.8	DZ-2R7D156J6T	16.0×25.0	0.2	35
2.7	20	1.0	DZ-2R7D206K8T	18.0×35.0	0.2	30
2.7	20	1.0	DZ-2R7D206K9T	18.0×40.0	0.2	30
2.7	22	1.0	DZ-2R7D226J7T	16.0×31.5	0.2	30
2.7	30	1.0	DZ-2R7D306K9T	18.0×40.0	0.2	30
2.7	33	1.0	DZ-2R7D336J9T	16.0×40.0	0.2	30

We tailor packaged product in series and parallel arrangements according to voltage and capacitance as required.

Standard Ratings (Series DZH 2.5V)

Max. operating voltage (V)	Rated capacitance (F)	Max. Leakage Current (mA) after 24h	ELNA Parts No.	φ D×L (mm)	Internal resistance (Ω max.) at 1kHz	Internal resistance (mΩ) at 1kHz (measurement value)
2.5	50	1.0	DZH-2R5D506K9T	18.0×40.0	0.08	30
2.5	100	2.0	DZH-2R5D107S35T	25.0×40.0	0.08	20
2.5	300	5.0	DZH-2R5D307S57T	35.0×50.0	0.08	15

We tailor packaged product in series and parallel arrangements according to voltage and capacitance as required.

High power type Capacitors

GREEN CAP 70°C Low ESR 2.5V / 2.7V

- Low internal resistance allows boosting charge and heavy-current discharge. (ampere level)
- Pollution-Free ; with no pollutants such as Cd or Pb.
- Unlike batteries, excellent charge and discharge characteristics with no chemical reaction

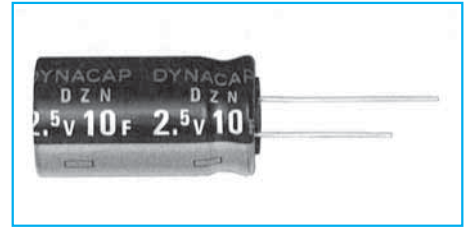
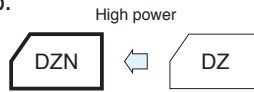

Marking color : White print on a blue sleeve

Specifications

Item	Performance	
Category temperature range (°C)	-25 to +70	
Tolerance at rated capacitance (%)	-20 to +80	
Internal resistance at 1 kHz	Refer to the following page	
Characteristics at high and low temperature	Percentage of capacitance change	Within ±30% of the value at 20°C
	Internal resistance	Less than five times of the value at 20°C
Endurance (70°C)	Test time	1000 hours
	Percentage of capacitance change	Within ±30% of the initial measured value
	Internal resistance	Less than four times of the initial specified value
Shelf life (70°C)	Test time : 1000 hours ; Same as endurance.	
Applicable standards	Conforms to JIS C5160-1 2009 (IEC 62391-1 2006)	

Outline Drawing

Unit : mm

φD	6.3	8	10	12.5	16	18
F	2.5	3.5	5.0		7.5	
φd		0.6			0.8	
α			2.0			

Part numbering system (example : 2.5V10F)

DZN	—	2R5	D	106	(H8)	T
Series code		Rated voltage symbol	Terminal code	Rated capacitance symbol	Casing symbol	

Part number is refer to the following page.

NOTE
Design, Specifications are subject to change without notice.
Ask factory for technical specifications before purchase and/or use.

Standard Ratings (Series DZ 2.5V)

Max. operating voltage (V)	Rated capacitance (F)	Max. Leakage Current (mA) after 24h	ELNA Parts No.	φ D×L (mm)	Internal resistance (Ω max.) at 1kHz	Internal resistance (mΩ) at 1kHz (measurement value)
2.5	0.7	0.1	DZN-2R5D704G4T	8.0×15.0	0.4	200
2.5	0.9	0.1	DZN-2R5D904F4T	6.3×14.0	0.4	300
2.5	1.0	0.1	DZN-2R5D105G3T	8.0×12.0	0.3	150
2.5	1.0	0.1	DZN-2R5D105G4T	8.0×15.0	0.3	150
2.5	1.0	0.1	DZN-2R5D105T	8.0×22.0	0.3	120
2.5	2.7	0.2	DZN-2R5D275G5T	8.0×22.0	0.3	120
2.5	3.3	0.2	DZN-2R5D335H5T	10.0×20.0	0.2	60
2.5	3.3	0.2	DZN-2R5D335T	12.5×23.0	0.2	60
2.5	4.7	0.3	DZN-2R5D475H5T	10.0×20.0	0.1	70
2.5	4.7	0.3	DZN-2R5D475T	12.5×31.5	0.1	35
2.5	6.8	0.4	DZN-2R5D685H7T	10.0×30.0	0.1	40
2.5	10	0.5	DZN-2R5D106H8T	10.0×35.0	0.1	35
2.5	10	0.5	DZN-2R5D106Z8T	12.5×36.5	0.1	30
2.5	10	0.5	DZN-2R5D106T	18.0×35.0	0.1	25
2.5	15	0.7	DZN-2R5D156J5T	16.0×20.0	0.1	30
2.5	20	0.8	DZN-2R5D206K8T	18.0×35.0	0.1	25
2.5	20	0.8	DZN-2R5D206T	18.0×40.0	0.1	20
2.5	22	0.8	DZN-2R5D226J6T	16.0×25.0	0.1	25
2.5	30	0.8	DZN-2R5D306K9T	18.0×40.0	0.1	25
2.5	33	0.8	DZN-2R5D336J8T	16.0×35.5	0.1	25
2.5	50	1.0	DZN-2R5D506T	25.0×40.0	0.03	15
2.5	100	1.0	DZN-2R5D107S37T	25.0×50.0	0.03	15
2.5	100	1.0	DZN-2R5D107T	35.0×50.0	0.03	8
2.5	200	2.0	DZN-2R5D207S57T	35.0×50.0	0.03	8

We tailor packaged product in series and parallel arrangements according to voltage and capacitance as required.

Standard Ratings (Series DZ 2.7V)

Max. operating voltage (V)	Rated capacitance (F)	Max. Leakage Current (mA) after 24h	ELNA Parts No.	φ D×L (mm)	Internal resistance (Ω max.) at 1kHz	Internal resistance (mΩ) at 1kHz (measurement value)
2.7	0.7	0.2	DZN-2R7D704G4T	8.0×15.0	0.4	200
2.7	0.9	0.2	DZN-2R7D904F4T	6.3×14.0	0.4	300
2.7	1.0	0.2	DZN-2R7D105G3T	8.0×12.0	0.3	150
2.7	1.0	0.2	DZN-2R7D105G4T	8.0×15.0	0.3	150
2.7	1.0	0.2	DZN-2R7D105G5T	8.0×22.0	0.3	120
2.7	2.7	0.3	DZN-2R7D275G5T	8.0×22.0	0.3	120
2.7	3.3	0.3	DZN-2R7D335H5T	10.0×20.0	0.2	90
2.7	3.3	0.3	DZN-2R7D335Z6T	12.5×23.0	0.2	60
2.7	4.7	0.4	DZN-2R7D475H5T	10.0×20.0	0.1	70
2.7	4.7	0.4	DZN-2R7D475Z7T	12.5×31.5	0.1	35
2.7	6.8	0.5	DZN-2R7D685H7T	10.0×30.0	0.1	40
2.7	10	0.6	DZN-2R7D106H8T	10.0×35.0	0.1	35
2.7	10	0.6	DZN-2R7D106Z8T	12.5×36.5	0.1	30
2.7	10	0.6	DZN-2R7D106K8T	18.0×35.0	0.1	25
2.7	15	0.8	DZN-2R7D156J6T	16.0×25.0	0.1	40
2.7	20	1.0	DZN-2R7D206K8T	18.0×35.0	0.1	25
2.7	20	1.0	DZN-2R7D206K9T	18.0×40.0	0.1	25
2.7	22	1.0	DZN-2R7D226J7T	16.0×31.5	0.1	25
2.7	30	1.0	DZN-2R7D306K9T	18.0×40.0	0.1	25
2.7	33	1.0	DZN-2R7D336J9T	16.0×40.0	0.1	25

We tailor packaged product in series and parallel arrangements according to voltage and capacitance as required.

For Low Temperature Type Capacitors

GREEN CAP

70°C

2.5V

For -40°C

- For Low Temperature (-40°C).
- Pollution-Free ; with no pollutants such as Cd or Pb.
- Unlike batteries, excellent charge and discharge characteristics with no chemical reaction.

For Low Temperature

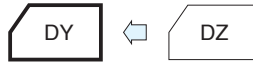

Marking color : White print on a brown sleeve

Specifications

Item	Performance		
Category temperature range (°C)	-40 to +70		
Tolerance at rated capacitance (%)	-20 to +80		
Internal resistance at 1 kHz	Refer to the Standard Ratings		
Characteristics at high and low temperature	Percentage of capacitance change	-20 to +70°C -40 to <-25°C	Within ±30% of the value at 20°C Within ±50% of the value at 20°C
	Internal resistance	-20 to +70°C -40 to <-25°C	Less than five times of the value at 20°C Less than ten times of the value at 20°C
		Test time	1000 hours
	Endurance (70°C)	Percentage of capacitance change	Within ±30% of initial value
Internal resistance		Less than four times of the initial specified value	
Shelf life (70°C)		Test time : 1000 hours ; Same as endurance.	
Applicable standards	Conforms to JIS C5160-1 2009 (IEC 62391-1 2006)		

Outline Drawing

Unit : mm

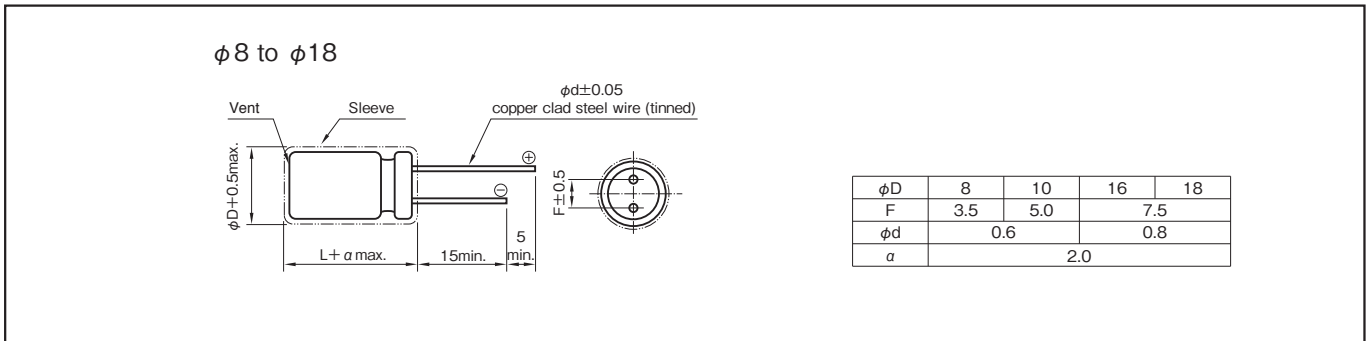

Part numbering system (example : 2.5V10F)

DY	—	2R5	D	106	H8	T
Series code		Rated voltage symbol	Terminal code	Rated capacitance symbol	Casing symbol	

Part number is refer to the following table.

Standard Ratings

Max. operating voltage (V)	Rated capacitance (F)	Max. Leakage Current (mA) after 24h	ELNA Parts No.	φD×L (mm)	Internal resistance (Ω max.) at 1kHz	Internal resistance (mΩ) at 1kHz (measurement value)
2.5	1.0	0.1	DY-2R5D105G3T	8.0×12.0	1.0	200
2.5	1.0	0.1	DY-2R5D105G4T	8.0×15.0	1.0	200
2.5	2.7	0.2	DY-2R5D275G5T	8.0×22.0	0.5	120
2.5	3.3	0.2	DY-2R5D335H5T	10.0×20.0	0.3	60
2.5	4.7	0.3	DY-2R5D475H5T	10.0×20.0	0.2	70
2.5	6.8	0.4	DY-2R5D685H7T	10.0×30.0	0.2	40
2.5	10	0.5	DY-2R5D106H8T	10.0×35.0	0.2	35
2.5	15	0.7	DY-2R5D156J5T	16.0×20.0	0.2	30
2.5	20	0.8	DY-2R5D206K8T	18.0×35.0	0.2	25
2.5	22	0.8	DY-2R5D226J6T	16.0×25.0	0.2	25
2.5	30	0.8	DY-2R5D306K9T	18.0×40.0	0.2	25
2.5	33	0.8	DY-2R5D336J8T	16.0×35.5	0.2	25

NOTE

Design, Specifications are subject to change without notice. Ask factory for technical specifications before purchase and/or use.

Packed Type

GREEN CAP

70°C

5.0V

- High-voltage capacitor which connected DZ in series.
- Pollution-Free ; with no pollutants such as Cd or Pb.
- Unlike batteries, excellent charge and discharge characteristics with no chemical reaction.

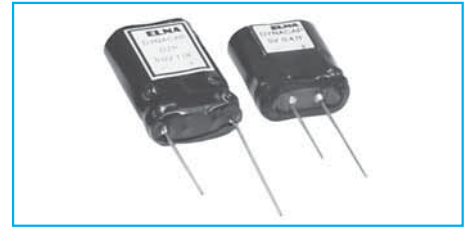
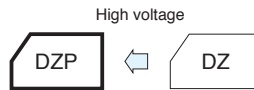

Marking color : White print on a brown sleeve

Specifications

Item	Performance	
Category temperature range (°C)	-25 to +70	
Tolerance at rated capacitance (%)	-20 to +80	
Internal resistance at 1 kHz	Refer to the Standard Ratings	
Characteristics at high and low temperature	Percentage of capacitance change	Within ±30% of the value at 20°C
	Internal resistance	Less than five times of the value at 20°C
Endurance (70°C)	Test time	1000 hours
	Percentage of capacitance change	Within ±30% of initial value
	Internal resistance	Less than four times of the initial specified value
Shelf life (70°C)	Same as endurance.	
Applicable standards	Conforms to JIS C5160-1 2009 (IEC 62391-1 2006)	

Outline Drawing

Unit : mm

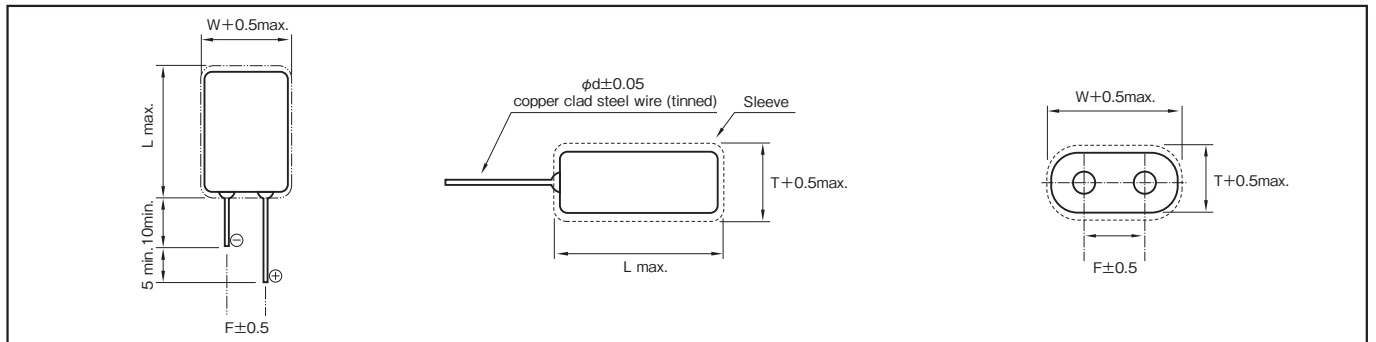

Part numbering system (example : 5.0V0.47F)					
Series code	Rated voltage symbol	Terminal code	Rated capacitance symbol	Casing symbol	Additional code
DZP	5	V	474	G3	TS1

Part number is refer to the following table.

Standard Ratings

Max. operating voltage (V)	Rated capacitance (F)	Max. Leakage Current (mA) after 24h	ELNA Parts No.	T×W×L (mm)	φd	F	Internal resistance (Ω max.) at 1kHz	Internal resistance (mΩ) at 1kHz (measurement value)
5.0	0.47	0.2	DZP-5V474G3TS1A	8.5×17.0×16.0	0.6	5.1	2.0	600
			DZP-5V474G3TS1B			12.1		
5.0	1.0	0.3	DZP-5V105G5STS1A	8.5×17.0×24.0	0.6	5.1	1.0	250
			DZP-5V105G5STS1B			12.1		
5.0	1.5	0.4	DZP-5V155G5STS1A	8.5×17.0×24.0	0.6	5.1	1.0	250
			DZP-5V155G5STS1B			12.1		
5.0	3.3	0.8	DZP-5V335H7TS1A	10.5×21.0×34.0	0.6	5.5	0.4	100
			DZP-5V335H7TS1B			15.5		
5.0	4.7	1.0	DZP-5V475H8TS1A	10.5×21.0×39.0	0.6	5.5	0.4	80
			DZP-5V475H8TS1B			15.5		

NOTE

Design, Specifications are subject to change without notice.
Ask factory for technical specifications before purchase and/or use.

Large capacitance, High energy type Capacitors

GREEN CAP

60°C

- Most suitable for energy storage with large capacitance.
- Terminals arranged in the same orientation provide easy connection.
- Unlike batteries, safe and high reliability without containing active and hazardous substances.
- Unlike batteries, excellent charge and discharge characteristics with no chemical reactions.

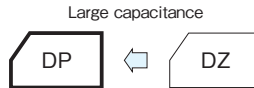

Marking color : White print on a black sleeve

Specifications

Item	Performance				
Category temperature range (°C)	-25 to +60				
Tolerance at rated capacitance (%)	-20 to +20				
Internal resistance at 1 kHz	Rated capacitance (F)	500	600	1200	1500
	Internal resistance (mΩ)	12	10	10	10
Characteristics at high and low temperature	Percentage of capacitance change	Within ±30% of value at 20°C			
	Internal resistance	Less than five times of the value at 20°C			
Endurance (60°C)	Test time	2000 hours			
	Percentage of capacitance change	Within ±30% of the initial measured value			
	Internal resistance	Less than four times of the initial specified value			
Shelf life (60°C)	Test time : 2000 hours ; Same as endurance.				
Applicable standards	Conforms to JIS C5160-1 2009 (IEC 62391-1 2006)				

Outline Drawing

Unit : mm

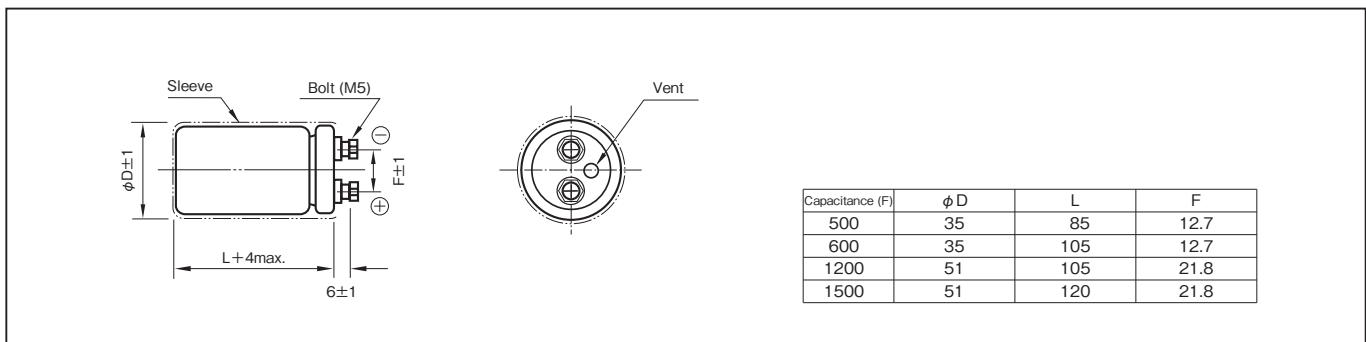

Standard Ratings

Max. operating voltage (V)	Rated capacitance (F)	ELNA Parts No.	φD×L (mm)	*Internal resistance (mΩ) at 1kHz (measurement value)
2.5	500	DP-2R5D507A85	35.0× 85.0	4.0
2.5	600	DP-2R5D607AA5	35.0×105.0	3.2
2.5	1200	DP-2R5D128CA5	51.0×105.0	3.0
2.5	1500	DP-2R5D158CC0	51.0×120.0	3.0

* Internal resistance are not guaranteed values, but measurement value.

We tailor packaged product in series and parallel arrangements according to voltage and capacitance as required.

Part numbering system (example : 2.5V600F)

DP	—	2R5	D	607	AA5
Series code		Max.operating voltage symbol	Rated capacitance symbol		Casing symbol

NOTE

Design, Specifications are subject to change without notice.
Ask factory for technical specifications before purchase and/or use.

1 Description of Electric Double Layer Capacitor

1-1 Basic Concepts

Generally capacitors are constructed with a dielectric placed between opposed electrodes, functioning as capacitors by accumulating charges in the dielectric material. Aluminum electrolytic and tantalum electrolytic capacitors, for example, use an aluminum oxide film and a tantalum oxide film as the dielectric, respectively.

On the other hand, Electric Double Layer Capacitors have no visible dielectric in a general sense but utilize the state referred to as the electric double layer, which is developed naturally on the interface between substances, as the function of dielectric.

1-2 Operating Principle

The Electric Double Layer represents the state in which positive and negative charges exist at a very short distance on the boundary where contact occurs between two different substances (e.g. solid and liquid). By externally applying a voltage below a certain voltage to the boundary, higher charges can be accumulated. Accordingly, charge and discharge of electric double layer capacitors utilize adsorption and desorption of ions to the ionic adsorption layer (Electric Double Layer) formed on the electrode surface of the activated carbon used for electrodes.

Applying DC voltage externally across the electrodes of the Electric Double Layer allows almost no passage of current up to a certain voltage, exhibiting a condition like insulation.

However, the application of voltages exceeding the certain voltage causes electrolysis to occur in the electrolyte, resulting in abrupt passage of current.

This voltage determines the resistance of voltage of an Electric Double Layer Capacitor. We use an organic electrolyte and its standard electrolysis occurs at the voltage of about 2.5 to 3V.

1-3 Advantages and Disadvantages of Electric Double Layer Capacitor

[Advantages]

- (1) Small size and capacitance in farads (F) available by utilizing the activated carbon electrode with a large surface area
- (2) No special charging circuit and constrains during discharge are required.
- (3) No effect on the life through overcharging and overdischarging
- (4) Environmentally clean energy

[Disadvantage]

- (1) The life is limited due to the use of electrolyte.
- (2) Series connection is required when used with a low resistance of voltage at a high voltage.
- (3) Cannot be used in AC circuits due to high internal resistance unlike aluminum electrolytic capacitors.

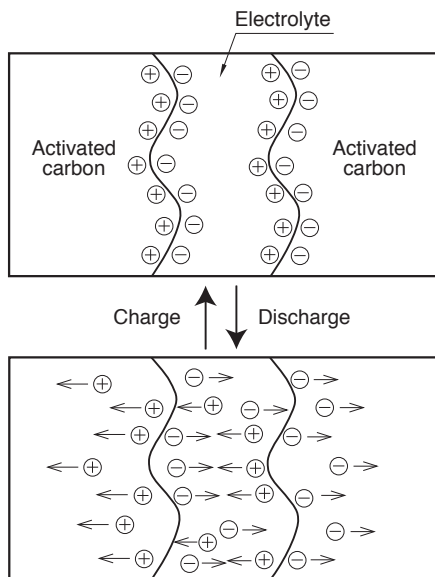

Fig.1 Schematic of Principle of Electric Double Layer Capacitor

1-4 Construction of DYNACAP

The series which consists of coin cells is similar to that of coin-type batteries as shown in Fig.2. DYNACAP contains a single cell or two to three cells stacked in series.

Since these series have a large electrode-to-electrode distance and a small electrode area exhibiting a large internal resistance, they are suitable for the memory backup application that involves microcurrent discharge.

The cylindrical cell construction as seen in the DZ and DZN series has the construction similar to that of aluminum electrolytic capacitors as shown in Fig.3.

These series have a small electrode-to-electrode distance, allowing a large electrode area because of the winding structure. This decreases the internal resistance, which is primary suitable for applications requiring high-power such as motor drive and LED lighting that need high currents.

2 Description of Life Expectancy

Generally, the life of Electric Double Layer Capacitors is largely affected by the ambient temperature.

The expected life is approximated by the equation as shown below:

$$L = L_0 \times 2 \left(\frac{T_0 - T}{10} \right)$$

Where,

- L : Expected lifetime at temperature T
- L₀ : Lifetime at temperature T₀
- T : Expected working temperature
- T₀ : Upper category temperature

Note that the above equation does not cover charge and discharge. In the case of charge and discharge, heat generation occurs inside a capacitor; the temperature rise by this heat generation must also be considered.

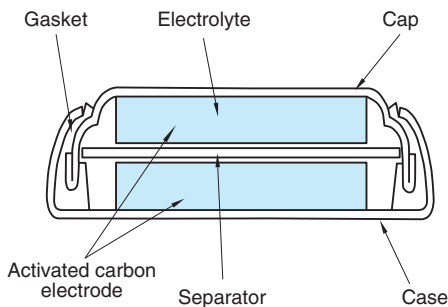

Fig.2 Example of Basic Construction of Coin Cell

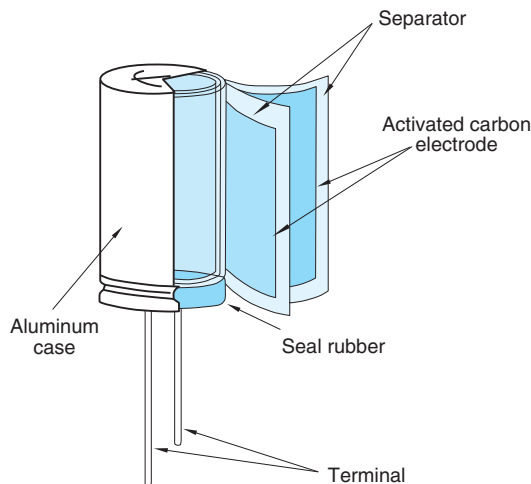

Fig.3 Example of Basic Construction of Cylindrical Cell

3 Calculation Method of Discharge Time

3-1 Approximating the Discharge Time of Basic Constant Current Discharge

The discharge time at the constant current of a capacitor can be calculated by the following equation.

$$t = (C \times \Delta V) / I$$

Where,

- t : Discharge time (sec.)
- C : Capacitor capacitance (F)
- ΔV : Working voltage range (V)
- I : Discharge current (A)

As an example, we calculate the discharge time when a capacitor of the DB series 5.5V 1F is charged with 5V and discharged to 3V at a constant current of 1 mA. Since the working voltage range ΔV is 2V from 5 – 3V, $t = (1F \times 2V) / 0.001A$ from the above equation, and the discharge time can be calculated as 2,000 seconds (about 33 minutes). Note that the actual discharge time may be different because this equation does not cover the effect of the self-discharge and the IR drop by internal resistance described below.

3-2 Effect of Self-discharge at Microcurrents

When backup is made by discharge with a micro-current below some μA especially for the memory backup application and the like, the discharge time must be determined while taking into account the self-discharge as shown in Fig.4.

The value closer to the actual discharge curve is obtained by adding the voltage drop through the self-discharge determined from the voltage retention characteristic test to the discharge curve given by calculation.

Note that the value of self-discharge varies by the charge time, charging current and an ambient temperature.

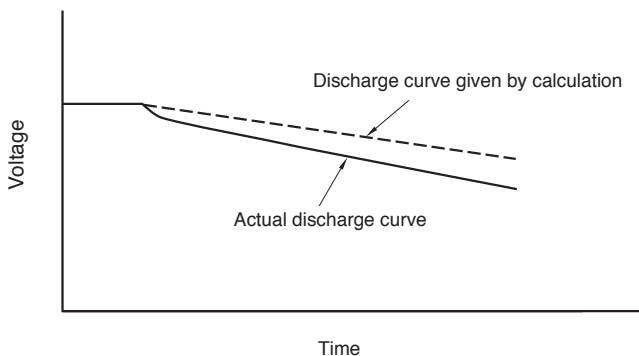

Fig.4 Example of Discharge Curve involving Self-Discharge

3-3 Effect of IR Drop at Large Currents

When a large Current discharge and a capacitor with a high internal resistance are used, the effect of IR drop by the product of the internal resistance and the current must be considered as shown in Fig.5.

When a large current is required in a very short time, or a large instantaneous current flows at the start of discharge, the voltage drop indicated with ΔV1 counts. However, when the discharge continues as it is, the discharge curve indicates in a manner showing a slow diffusion and then keeps a constant straight line.

We also make calculation including ΔV2 of the intersection extending from the initial discharge and the discharge straight line section including the diffusion curve when indicating the DC internal resistance.

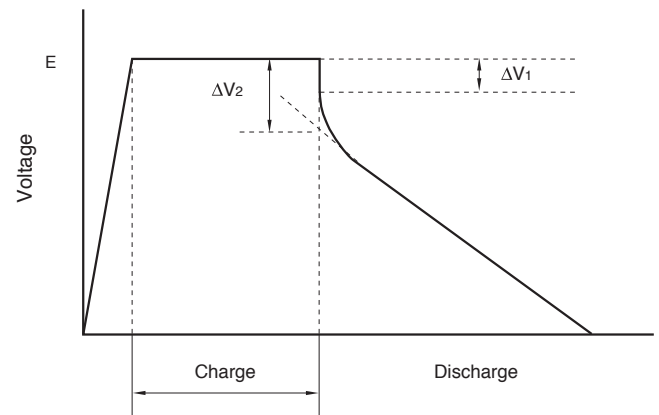

Fig.5 Example of Discharge Curve involving IR Drop

Due to IR drop, the shape of the discharge curve varies by the internal resistance and ambient temperature for each series.

4 Series-parallel connection packaged products.

Electric Double Layer Capacitors have a low operating voltage per cell. To deal with this, ELNA is ready to offer series packaging for high operating voltages to meet to various needs. Please consult with us on optimization and design.

Packaged item

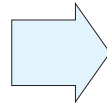

Example of packaged item

In case of a low voltage (up to about 24 V) for the DZ and DZN series with relatively low capacitance, we are preparing simple packaged products. No full-scale voltage equalization circuit has been equipped yet, but comparatively low cost and flexible layout can be realized.

5 Moisture-proof provision

If a electric double layer capacitor is used in a heat-and-high-humidity environment, the characteristic will deteriorate. We can improve the durability in heat-and-high-humidity environment by coating of special resin. Please consult about resin coating.

6 Applications

Features & Benefits of Electric Double Layer Capacitor

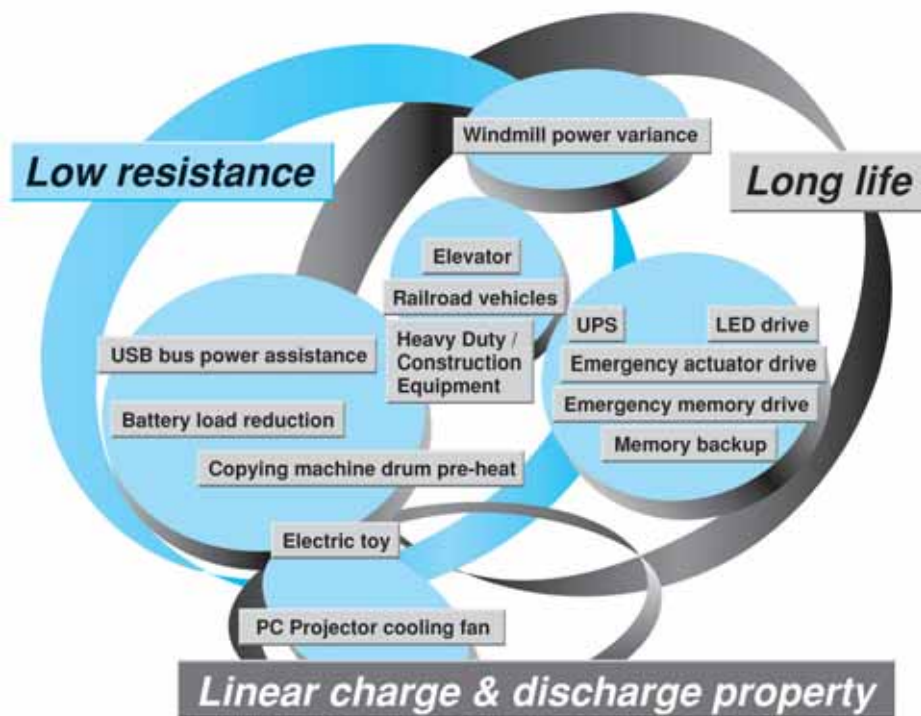

7 Electric Characteristics Data

7-1 Coin type for memory back-up

DYNACAP Series DXJ
5.5V 0.33F/DXJ-5R5H334 φ11.5×5L (mm)

DYNACAP Series DHL
5.5V 0.22F/DHL-5R5D224T φ13.5×9.5L (mm)

■ Endurance (85°C 5.5V.DC)

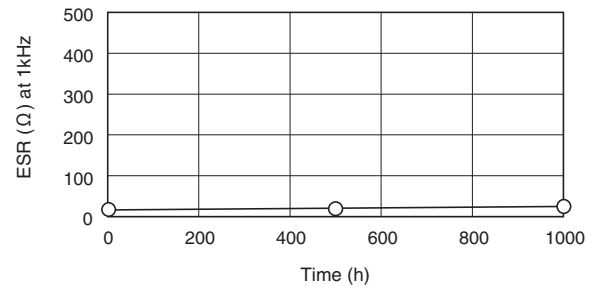
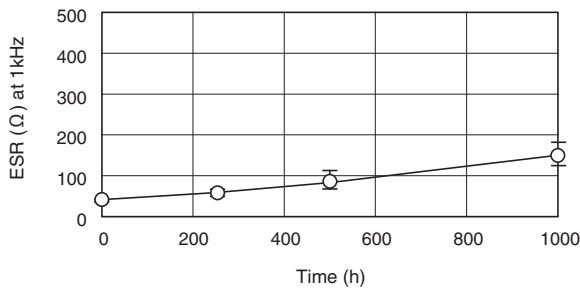
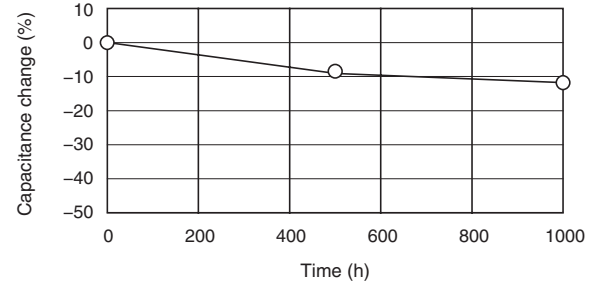
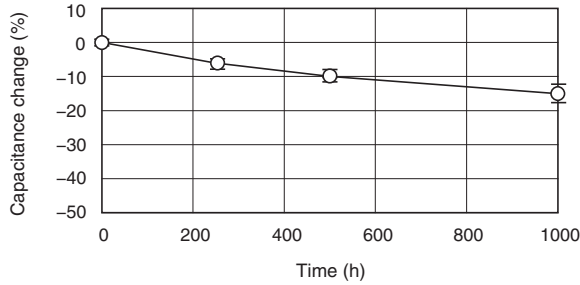

■ Discharge characteristics

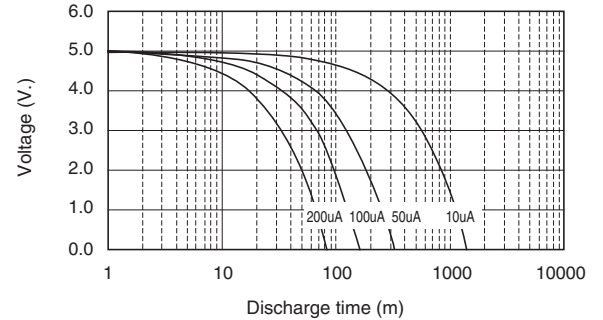
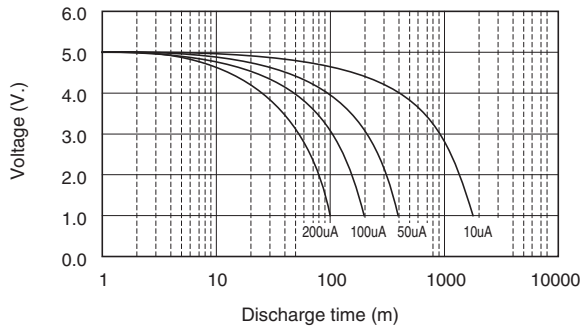

■ Characteristics at high and low temperature

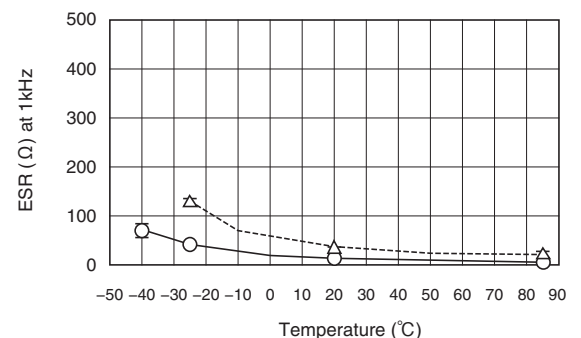
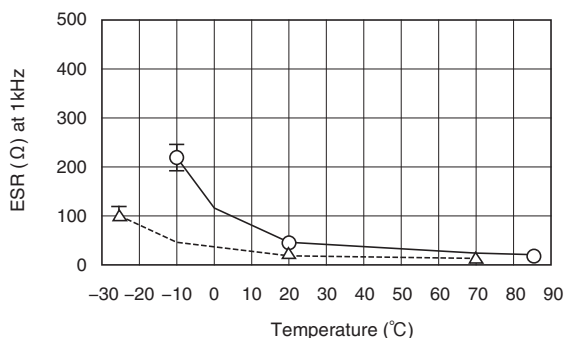
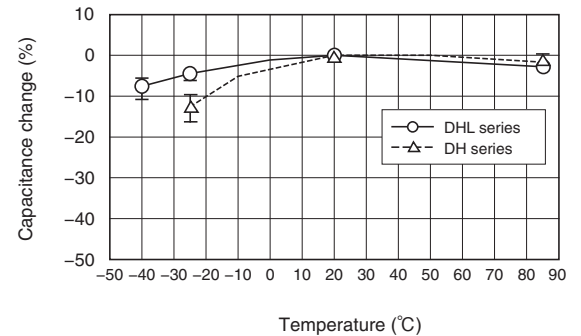
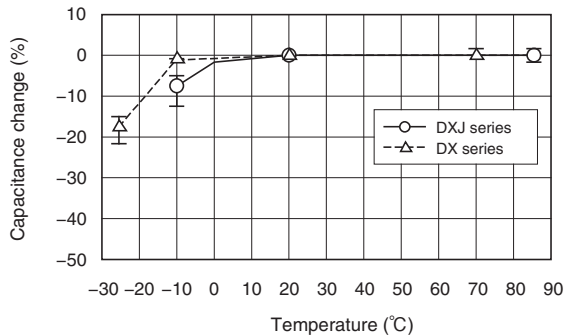

DYNACAP Series DZK
3.3V 0.22F/DSK-3R3H224 $\phi 6.8 \times 2.1L$ (mm)

■ Endurance (60°C 3.3V.DC)

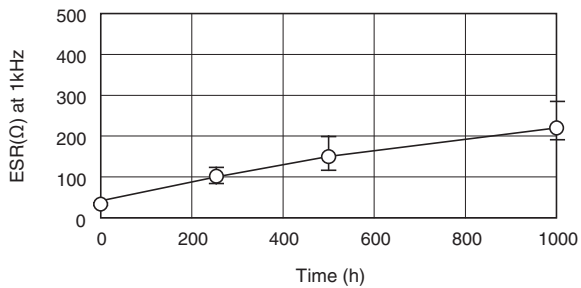
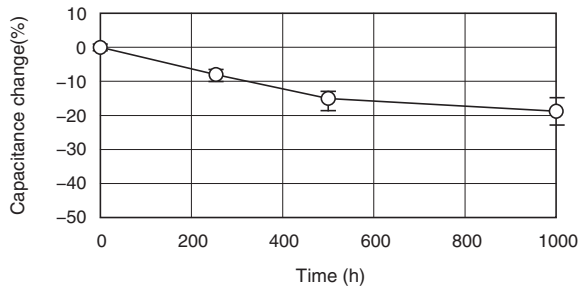

■ Discharge characteristics

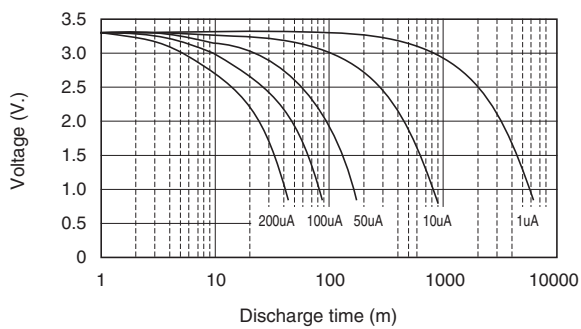

■ Characteristics at high and low temperature

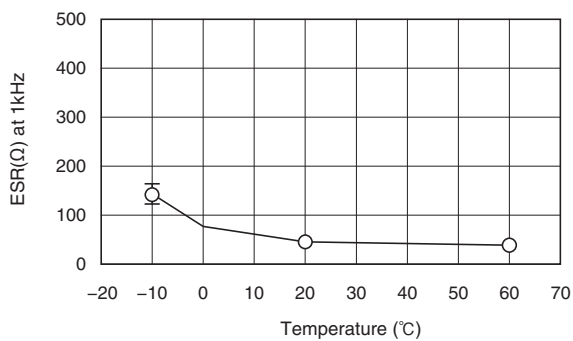
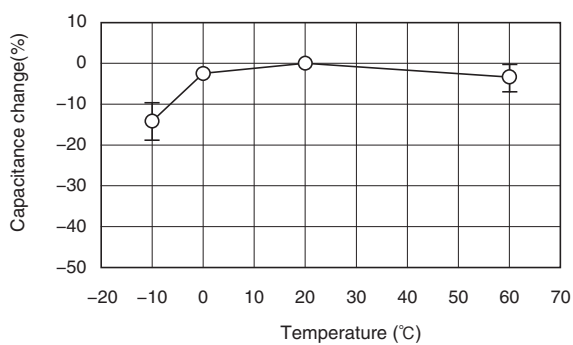

7-2 Cylindrical type for power

DYNACAP Series DZN
2.5V 1F/DZN-2R5D105T $\phi 8 \times 22L$ (mm)

DYNACAP Series DZN
2.5V 100F/DZN-2R5D107T $\phi 35 \times 50L$ (mm)

■ Endurance (70°C 2.5V.DC)

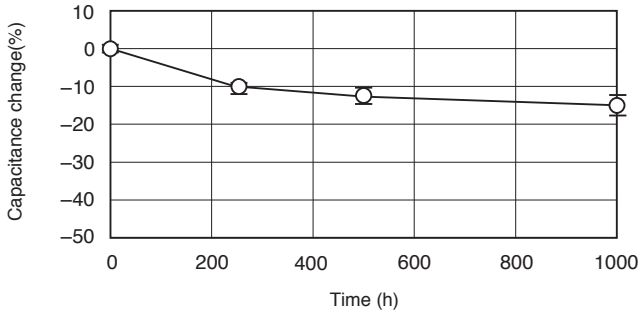

■ Endurance (70°C 2.5V.DC)

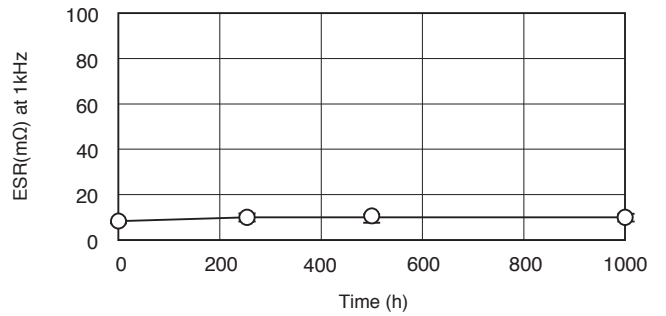
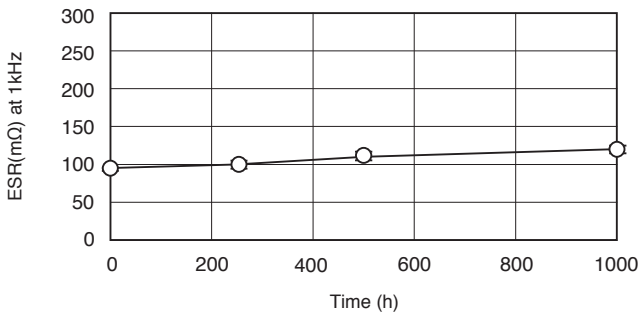
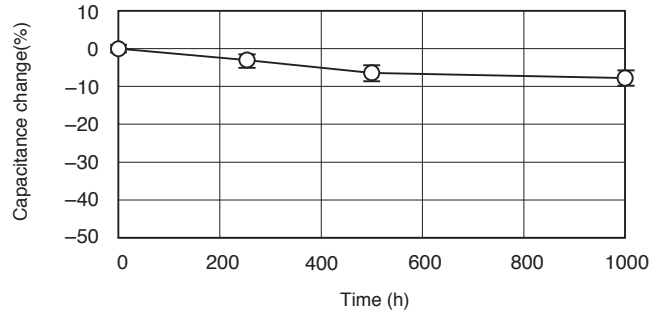

■ Discharge characteristics

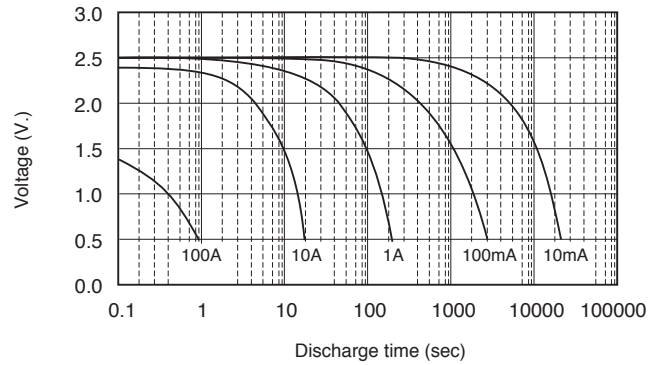
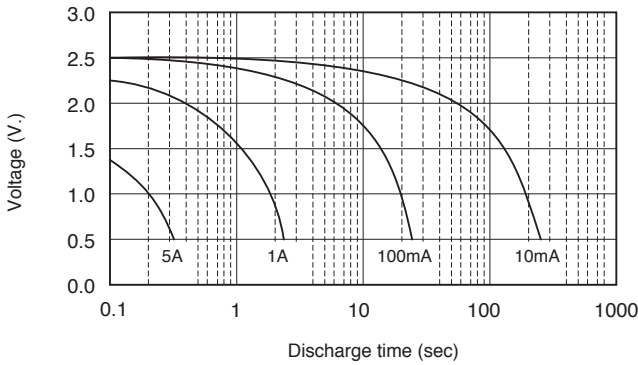

■ Characteristics at high and low temperature

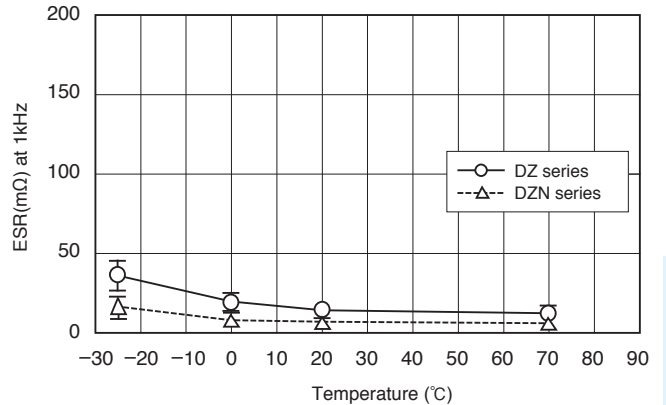
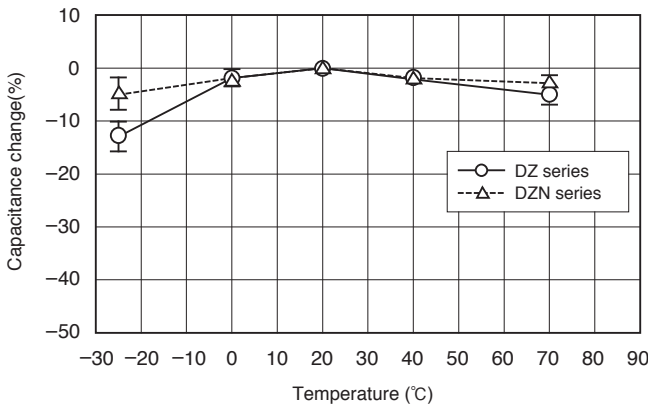

For DC-Link circuits

85°C

DC-LINK

- Used in DC-Link circuits, can replace electrolytic capacitor.
- PP film design, good temperature characteristics, stable capacity, low ESR, high ripple current handing capabilities, low Ls, long life.
- Aluminum case, filled with fire-retardant resin.
- Self-healing property.
- Used in Inverters of wind power and solar power, HEV or EV, welders, elevators, Motor Driver systems.



Specifications

Item	Performance	
Category temperature range (°C)	-40 to +85 (at Hotspot in capacitor)	
Tolerance at rated capacitance (%)	±10 (20°C, 50 to 120Hz)	
Over Voltage	Rated voltage × 1.1	30% of on-load-duration
	Rated voltage × 1.15	30 min/day
	Rated voltage × 1.2	5 min/day
	Rated voltage × 1.3	1 min/day
	Rated voltage × 1.5	30 ms every time, 100ms/day
Dielectric Dissipation Factor	2×10 ⁻⁴ or less	
Life Expectancy	100000 hours (at Hotspot in capacitor = 70°C)	
Failure Rate	50Fit	
Withstanding DC Voltage	Between Terminals	Rated voltage × 1.5 10s
	Between Terminals and Case	3000 VAC 10s (20°C, 50Hz)
Insulation Resistance	5000MΩ · µF or less (20°C, 100V DC, 1min)	
Reference Standard	IEC 61071	

Outline Drawing

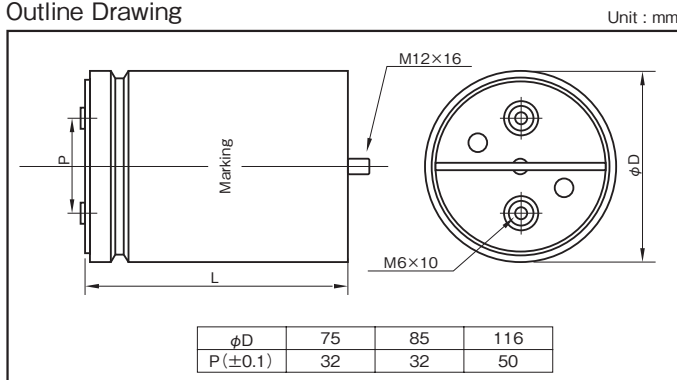

Part numbering system (1100V420µF)

NYD	—	1100	V	421	K	FD6	6BB
Series code		Rated voltage symbol		Rated capacitance symbol	Capacitance tolerance symbol	Casing symbol	Additional symbol

Cautions

1. Please do not exceed the specified current.
2. Please confirm voltage waveform and do not exceed the specified voltage.
3. The expected life time changes under the effect of the applied voltage and the inside temperature of the capacitor. Please refer to the following figure.

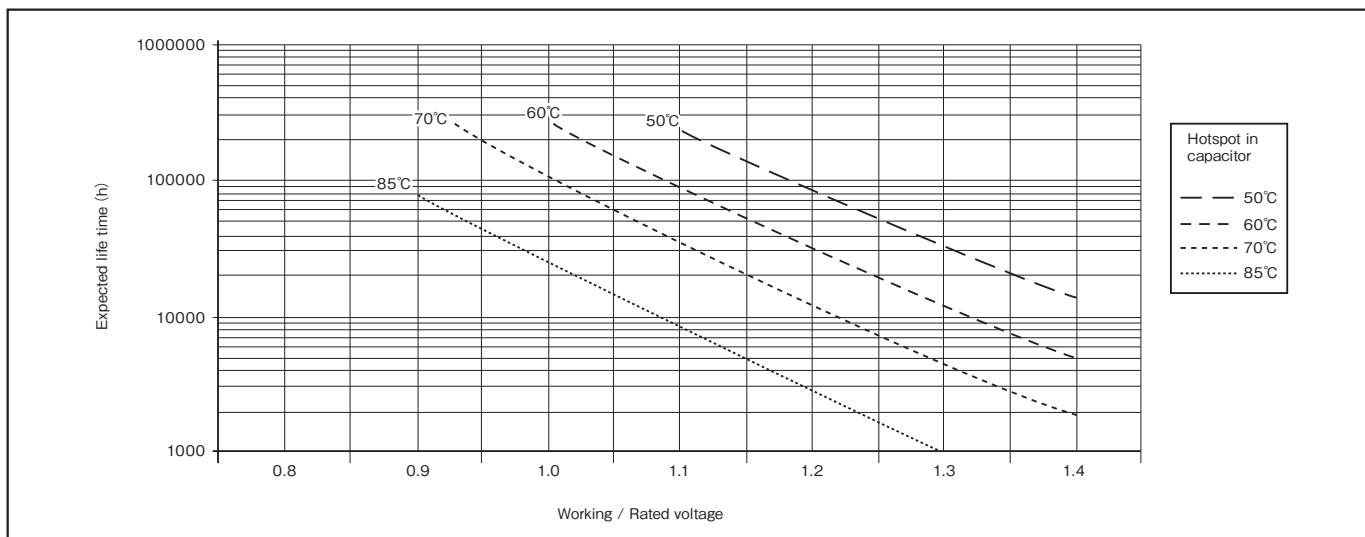

NOTE

Design, Specifications are subject to change without notice. Ask factory for technical specifications before purchase and/or use.

Standard Ratings

Rated voltage (V)	Rated capacitance (µF)	Case (mm)		Casing symbol	Maximum current (Arms)	Thermal resistance (K/W)	Maximum peak current (A)	Series resistance (mΩ)	Self-inductance (nH)	ELNA Parts No.
		φD	L							
880	220	85	70	F70	50	5.6	2640	1.9	60	NYD-880V221KF706BB
	260	75	95	E95	45	5.6	2600	2.8	80	NYD-880V261KE956BB
	350	85	95	F95	50	5.1	3500	2.4	60	NYD-880V351KF956BB
	440	116	70	H70	65	5.8	5280	1.5	60	NYD-880V441KH706BB
	480	85	120	FC0	55	4.7	3840	2.8	60	NYD-880V481KFC06BB
	550	85	136	FD6	50	4.6	3850	3.0	60	NYD-880V551KFD66BB
	700	116	95	H95	70	5.4	7000	1.7	60	NYD-880V701KH956BB
	750	85	173	FH3	55	4.3	6750	3.7	60	NYD-880V751KFH36BB
	970	116	120	HC0	75	5.0	5820	1.9	60	NYD-880V971KHC06BB
	1100	116	132	HD2	75	4.9	6600	2.0	60	NYD-880V112KHD26BB
	1500	116	173	HH3	80	3.4	13500	2.4	60	NYD-880V152KHH36BB
1100	100	75	70	E70	35	6.0	1200	2.5	80	NYD-1100V101KE706BB
	140	85	70	F70	45	5.6	1680	2.1	60	NYD-1100V141KF706BB
	170	75	95	E95	40	5.6	1700	3.2	80	NYD-1100V171KE956BB
	230	75	120	EC0	40	4.7	1840	4.1	80	NYD-1100V231KEC06BB
	260	75	136	ED6	40	4.6	2080	4.4	80	NYD-1100V261KED66BB
	280	116	70	H70	60	5.8	2800	1.6	60	NYD-1100V281KH706BB
	350	75	173	EH3	40	4.2	3500	5.6	80	NYD-1100V351KEH36BB
	420	85	136	FD6	55	4.6	3200	2.2	60	NYD-1100V421KFD66BB
	450	116	95	H95	65	5.4	4500	1.9	60	NYD-1100V451KH956BB
	480	85	173	FH3	50	4.3	4800	4.3	60	NYD-1100V481KFH36BB
	610	116	120	HC0	70	5.0	5490	2.2	60	NYD-1100V611KHC06BB
	700	116	132	HD2	70	4.9	6300	2.3	60	NYD-1100V701KHD26BB
	940	116	173	HH3	70	3.4	9400	1.6	60	NYD-1100V941KHH36BB
1100	116	230	HN0	80	2.7	11000	1.5	100	NYD-1100V112KHN06BB	
1320	70	75	70	E70	35	6.0	1050	2.8	80	NYD-1320V700KE706BB
	110	75	95	E95	35	5.6	1540	3.8	80	NYD-1320V111KE956BB
	160	75	120	EC0	40	4.7	1600	4.6	80	NYD-1320V161KEC06BB
	180	75	136	ED6	40	4.6	1800	5.1	80	NYD-1320V181KED66BB
	220	85	120	FC0	45	4.7	2200	3.6	60	NYD-1320V221KFC06BB
	260	85	136	FD6	45	4.6	2600	3.9	60	NYD-1320V261KFD66BB
	310	116	95	H95	65	5.4	3720	2.0	60	NYD-1320V311KH956BB
	340	85	173	FH3	50	4.3	4080	4.9	60	NYD-1320V341KFH36BB
	420	116	120	HC0	65	5.0	4200	2.4	60	NYD-1320V421KHC06BB
	480	116	132	HD2	70	4.9	4800	2.6	60	NYD-1320V481KHD26BB
660	116	173	HH3	70	3.4	7920	3.1	60	NYD-1320V661KHH36BB	

ELECTRONIC COMPONENTS

ELNA CO., LTD.

<http://www.ena.co.jp/>

HEAD OFFICE	3-8-11 Shin-Yokohama, Kouhoku-ku, Yokohama-city, Kanagawa, 222-0033 Japan	TEL. +81-45-470-7251 FAX. +81-45-470-7261
SHIGA FACTORY	30 Ta-cho, Nagahama-city, Shiga, 529-0142 Japan	TEL. +81-749-73-3021 FAX. +81-749-73-2175
SHIRAKAWA OFFICE	9-32 Aza-sugiyama, Oaza-yone, Nishigo-mura, Nishishirakawa-gun, Fukushima, 961-8031 Japan	TEL. +81-248-48-1654 FAX. +81-248-25-5614

SALES OFFICE

ELNA AMERICA, INC. 3600 Dallas Hwy., Ste. 230 #389 Marietta, GA 30064, U.S.A.	TEL. +1-678-261-8284 FAX. +1-678-815-0892
ELNA ELECTRONICS SINGAPORE PTE.LTD. 103 Kallang Avenue, #04-01 AIS Industrial Building Singapore 339504	TEL. +65-62930181 FAX. +65-62966716
ELNA (SHANGHAI) CO., LTD. Room 6203, Rui Jin Hotel Business Center 118 Rui Jin 2 Road, Shanghai, China Post Code 200020	TEL. +86-21-64452269 FAX. +86-21-64452271
ELNA BANGKOK SALES OFFICE 88.90. Chalermpkrakiat Rama 9 Road, Nongborn, Pravct, Bangkok 10250, Thailand	TEL. +66-2-3985333 FAX. +66-2-3985337
ELNA MALAYSIA PENANG SALES OFFICE 2473, Tingkat Perusahaan 6, Free Trade Zone, Prai Industrial Estate, 13600 Prai, Penang, Malaysia	TEL. +60-4-3985369
EASTERN JAPAN OFFICE 3-8-11 Shin-Yokohama, Kouhoku-ku, Yokohama-city Kanagawa, 222-0033 Japan	TEL. +81-45-470-7254 FAX. +81-45-470-7260
WESTERN JAPAN OFFICE 6-1-15 Nishinakajima Yodogawa-ku, Osaka-city, Osaka, 532-0011 Japan	TEL. +81-6-6304-6831 FAX. +81-6-6304-8638

AFFILIATED COMPANY

TANIN ELNA CO., LTD. HEAD OFFICE 88.90. Chalermpkrakiat Rama 9 Road, Nongborn, Pravct, Bangkok 10250, Thailand	TEL. +66-2-3985333 FAX. +66-2-3985337
CHIANGMAI FACTORY 56 Mahidoal Road T.Sutep A.Muang Chiangmai 50200, Thailand.	TEL. +66-53-270206 FAX. +66-53-275064
ELNA-SONIC SDN.BHD. 2473, Tingkat Perusahaan 6, Free Trade Zone, Prai Industrial Estate, 13600 Prai, Penang, Malaysia.	TEL. +60-4-3992916 FAX. +60-4-3992925 Sales office TEL. +60-4-3985369
ELNA TOHOKU CO., LTD. AOMORI FACTORY 1-349-1 Okonoki, Kuroishi-city Aomori, 036-0357 Japan	TEL. +81-172-52-4166 FAX. +81-172-53-4609



CAUTION

Observe the following to ensure safe operation.

1. The models and specification values contained in this catalog are for reference purposes only. During actual use or when placing an order, please request "drawings" and make your purchase or use the purchased product based on those drawings.
2. In order to ensure that products are used correctly and safely, always make sure to read the cautions for using prior to using the product.

NOTE

1. Since the contents contained are subject to changes in specifications, dimensions and so forth without notice due to modification, please confirm the contents when placing an order. If any of the matters described here are unclear, please inquire at one of our nearby sales offices.
2. The contents of this catalog are valid as of December 2012.

Компания «Океан Электроники» предлагает заключение долгосрочных отношений при поставках импортных электронных компонентов на взаимовыгодных условиях!

Наши преимущества:

- Поставка оригинальных импортных электронных компонентов напрямую с производств Америки, Европы и Азии, а так же с крупнейших складов мира;
- Широкая линейка поставок активных и пассивных импортных электронных компонентов (более 30 млн. наименований);
- Поставка сложных, дефицитных, либо снятых с производства позиций;
- Оперативные сроки поставки под заказ (от 5 рабочих дней);
- Экспресс доставка в любую точку России;
- Помощь Конструкторского Отдела и консультации квалифицированных инженеров;
- Техническая поддержка проекта, помощь в подборе аналогов, поставка прототипов;
- Поставка электронных компонентов под контролем ВП;
- Система менеджмента качества сертифицирована по Международному стандарту ISO 9001;
- При необходимости вся продукция военного и аэрокосмического назначения проходит испытания и сертификацию в лаборатории (по согласованию с заказчиком);
- Поставка специализированных компонентов военного и аэрокосмического уровня качества (Xilinx, Altera, Analog Devices, Intersil, Interpoint, Microsemi, Actel, Aeroflex, Peregrine, VPT, Syfer, Eurofarad, Texas Instruments, MS Kennedy, Miteq, Cobham, E2V, MA-COM, Hittite, Mini-Circuits, General Dynamics и др.);

Компания «Океан Электроники» является официальным дистрибьютором и эксклюзивным представителем в России одного из крупнейших производителей разъемов военного и аэрокосмического назначения «JONHON», а так же официальным дистрибьютором и эксклюзивным представителем в России производителя высокотехнологичных и надежных решений для передачи СВЧ сигналов «FORSTAR».



JONHON

«JONHON» (основан в 1970 г.)

Разъемы специального, военного и аэрокосмического назначения:

(Применяются в военной, авиационной, аэрокосмической, морской, железнодорожной, горно- и нефтедобывающей отраслях промышленности)

«FORSTAR» (основан в 1998 г.)

ВЧ соединители, коаксиальные кабели, кабельные сборки и микроволновые компоненты:

(Применяются в телекоммуникациях гражданского и специального назначения, в средствах связи, РЛС, а так же военной, авиационной и аэрокосмической отраслях промышленности).



Телефон: 8 (812) 309-75-97 (многоканальный)

Факс: 8 (812) 320-03-32

Электронная почта: ocean@oceanchips.ru

Web: <http://oceanchips.ru/>

Адрес: 198099, г. Санкт-Петербург, ул. Калинина, д. 2, корп. 4, лит. А