

### FEATURES

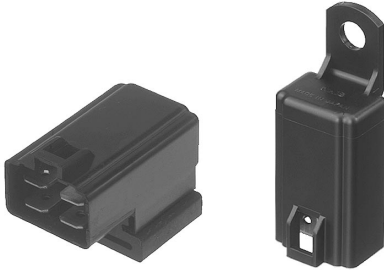

#### 1. Small size and light weight

For space saving, the outside dimensions of the main body are reduced to be 21.5 mm (length) × 14.4 mm (width) × 37 mm (height) (.846 × .567 × 1.457 inch). and the weight is also reduced to be approx. 19 g .67 oz (Direct coupling 1 Form A, 1 Form B type)

#### 2. Water tightness

Since the relays comply with the water tightness standards, JIS D 0203, water and dust will not enter the relay even if it is mounted in the engine area.

**3. Low operating power (1.4W) type is available (1 Form A, 1 Form B)**

**4. Since the terminal arrangement complies with JIS D5011 B4-M1, commercial connectors are available for these types of relays.**

### SPECIFICATIONS

#### Contact

Type		12 V DC			24 V DC
Arrangement		1 Form A	1 Form B	1 Form C	1 Form C
Initial contact resistance, max. (By voltage drop 6 V DC 1A)		50 m ohm			
Contact material		silver alloy			
Contact voltage drop, max.		0.3 V After electrical life test, by voltage drop 12 V DC 20 A (1.4 W type), 12 V DC 30 A (1.8 W type)	0.3 V After electrical life test, by voltage drop 12 V DC 20 A	0.4 V After electrical life test, by voltage drop 12 V DC 20 A	0.4 V After electrical life test, by voltage drop 24 V DC 10 A
Rating	Nominal switching capacity (resistive load)	20 A 12 V DC (1.4 W type) 30 A 12 V DC (1.8 W type)	20 A 12 V DC		10 A 24 V DC (ON: 2s, OFF: 2s)
	Max. switching voltage	16 V		15 V	30 V
	Max. switching current	120 A (1.4 W type) 150 A (1.8 W type)	120 A	100 A	50 A (Inrush current)
	Max. carrying current	20 A continuous (1.4 W type) 30 A for 1 min (1.8 W type)	20 A continuous	20 A continuous	10 A continuous
Nominal operating power		1.4 W / 1.8 W			1.8 W
Expected life (min. operations)	Mechanical (at 120 cpm)	10 <sup>6</sup>			5×10 <sup>5</sup>
	Electrical	20 A (1.4 W, 1.8 W type)	10 <sup>5</sup> (ON: 2s, OFF: 2s)	10 <sup>5</sup> (ON 2s, OFF 2s)	
		30 A (1.8 W type)	2×10 <sup>4</sup> (ON: 3s, OFF: 15s)		

# CA

## Characteristics (at 20°C 68°F)

Type	12 V DC		24 V DC
Max. operating speed	15 cpm (1.4 W type: at nominal load) 1.8 W type: at 20 A		15 cpm (at nominal load)
Initial insulation resistance	Min. 10 Ω at 500 V DC		
Initial breakdown voltage*1	Between open contacts	500 V rms for 1 min.	
	Between contacts and coil	500 V rms for 1 min.	
Operate time*2 (at nominal voltage)	Max. 10 ms at 20°C		Max. 10 ms
Release time (without diode)*2 (at nominal voltage)	Max. 10 ms at 20°C		Max. 10 ms
Shock resistance	Functional	Min. 200 m/s <sup>2</sup> {20 G}	Min. 100 m/s <sup>2</sup> {10 G}
	Destructive*4	Min. 1,000 m/s <sup>2</sup> {100 G}	
Vibration resistance	Functional*5	Rubber bracket A type: Min. 100 m/s <sup>2</sup> {10 G}, 50 to 500Hz Direct coupling type or Screw-mounting type: Min. 44.1 m/s <sup>2</sup> {4.5 G}, 10 to 100 Hz	Min. 44.1 m/s <sup>2</sup> {4.5 G}, 10 to 100Hz
	Destructive	Rubber bracket A type: Min. 100m/s <sup>2</sup> {10 G},50 to 500Hz Direct coupling type or Screw-mounting type: Min. 44.1 m/s <sup>2</sup> {4.5 G}, 10 to 100 Hz	Min. 44.1 m/s <sup>2</sup> {4.5 G}, 10 to 500Hz
Conditions for operation, transport and storage*6 (Not freezing and condensing low temperature)	Ambient temp.	-30°C to +80°C -22°F to +176°F	
	Humidity	5 to 85% R.H.	
Water-proof standard	Plastic sealed type: JIS DO203S2, Dust cover type: JIS DO203R2		JIS DO203S2
Unit weight	Rubber bracket A type : 23 g .81 oz		31 g 1.09 oz
	Direct coupling type or Screw-mounting type: 19 g .67 oz		

## Electrical life (min. operation)

	Nominal coil voltage, V DC	Motor load (operating frequency ON: 2 s, OFF: 2 s)	Halogen lamp load (operating frequency ON: 1 s, OFF: 14 s)
1 Form A, 1 Form B	12	10 <sup>5</sup> , 20 A 12 V DC	10 <sup>5</sup> , 20 A 12 V DC
1 Form C	12	10 <sup>5</sup> , 20 A 12 V DC	10 <sup>5</sup> , 20 A 12 V DC
	24	10 <sup>5</sup> , 10 A 24 V DC	10 <sup>5</sup> , 6 A 24 V DC

## Remarks

\* Specifications will vary with foreign standards certification ratings.

\*1 Detection current: 10 mA

\*2 Excluding contact bounce time

\*3 Half-wave pulse of sine wave: 11ms; detection time: 10μs

\*4 Half-wave pulse of sine wave: 6ms

\*5 Detection time: 10μs

\*6 Refer to 5. Conditions for operation, transport and storage mentioned in AMBIENT ENVIRONMENT (Page 61)

## ORDERING INFORMATION

CA 1a F S — 12 V — A — 5

Contact arrangement	Protective construction	Nominal operating power	Coil voltage (DC)	Mounting method	Classification by type
1a: 1 Form A 1b: 1 Form B 1 : 1 Form C	Nil: Plastic sealed type F: Dust cover type	Nil: Standard type (1.8 W) S: Low operating power type (1.4 W) (1 Form A, 1 Form B)	12 V 24 V (1 Form C only)	A: Rubber bracket A type (1 Form A, 1 Form B) N: Screw mounting type C: Direct coupling type	Nil: 1 Form C 5: 1 Form A or 1 Form B

Notes: 1. Type with resistor/diode inside are available as options. Please consult our sales office.

2. Standard packing: Carton: 20 pcs. Case: 200 pcs.

## COIL DATA

### 1) Standard type

Contact arrangement	Mounting type	Plastic sealed type	Dust cover type	Nominal voltage, V DC	Pick-up voltage, V DC (max.) (at 20°C 68°F)	Drop-out voltage, V DC (min.) (at 20°C 68°F)	Nominal operating current, mA (±10%) (at 20°C 68°F)	Coil resistance, Ω (±10%) (at 20°C 68°F)	Nominal operating power, mW (at 20°C 68°F)	Usable voltage range, V DC
1 Form A	Rubber bracket A	CA1a-12V-A-5	CA1aF-12V-A-5	12	8	0.6 to 6	150	80	1.8	10 to 16
	Screw-mounting	CA1a-12V-N-5	CA1aF-12V-N-5	12	8	0.6 to 6	150	80	1.8	10 to 16
	Direct coupling	CA1a-12V-C-5	CA1aF-12V-C-5	12	8	0.6 to 6	150	80	1.8	10 to 16
1 Form B	Rubber bracket A	CA1b-12V-A-5	CA1bF-12V-A-5	12	8	0.6 to 6	150	80	1.8	10 to 16
	Screw-mounting	CA1b-12V-N-5	CA1bF-12V-N-5	12	8	0.6 to 6	150	80	1.8	10 to 16
	Direct coupling	CA1b-12V-C-5	CA1bF-12V-C-5	12	8	0.6 to 6	150	80	1.8	10 to 16
1 Form C	Screw-mounting	CA1-DC12V-N	-	12	8	0.6	150	80	1.8	10 to 15
	Direct coupling	CA1-DC12V-C	-	12	8	0.6	150	80	1.8	10 to 15
	Screw-mounting	CA1-DC24V-N	-	24	16	1.2	75	320	1.8	20 to 30
	Direct coupling	CA1-DC24V-C	-	24	16	1.2	75	320	1.8	20 to 30

2) Low operating power type

Contact arrangement	Mounting type	Plastic sealed type	Dust cover type	Nominal voltage, V DC	Pick-up voltage, V DC (max.) (at 20°C 68°F)	Drop-out voltage, V DC (min.) (at 20°C 68°F)	Nominal operating current, mA (±10%) (at 20°C 68°F)	Coil resistance, Ω (±10%) (at 20°C 68°F)	Nominal operating power, mW (at 20°C 68°F)	Usable voltage range, V DC
1 Form A	Rubber bracket A	CA1aS-12V-A-5	CA1aFS-12V-A-5	12	8	0.6 to 6	120	100	1.4	10 to 16
	Screw-mounting	CA1aS-12V-N-5	CA1aFS-12V-N-5	12	8	0.6 to 6	120	100	1.4	10 to 16
	Direct coupling	CA1aS-12V-C-5	CA1aFS-12V-C-5	12	8	0.6 to 6	120	100	1.4	10 to 16
1 Form B	Rubber bracket A	CA1bS-12V-A-5	CA1bFS-12V-A-5	12	8	0.6 to 6	120	100	1.4	10 to 16
	Screw-mounting	CA1bS-12V-N-5	CA1bFS-12V-N-5	12	8	0.6 to 6	120	100	1.4	10 to 16
	Direct coupling	CA1bS-12V-C-5	CA1bFS-12V-C-5	12	8	0.6 to 6	120	100	1.4	10 to 16

**DIMENSIONS**

mm inch

1. 1 Form A/1 Form B  
Rubber bracket A type

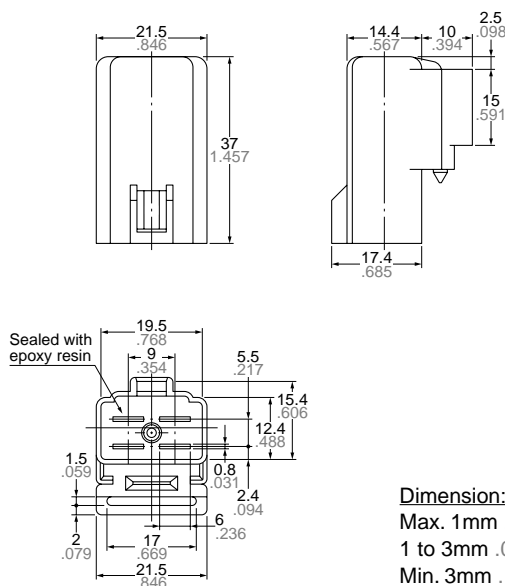

SCHMATIC (Bottom View)

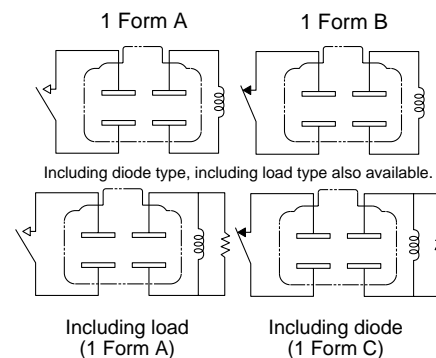

**Dimension:**  
 Max. 1mm .039 inch:  
 1 to 3mm .039 to .118 inch:  
 Min. 3mm .118 inch:

**General tolerance**  
 ±0.1 ±.004  
 ±0.2 ±.008  
 ±0.3 ±.012

2. 1 Form A/1 Form B  
Screw-mounting type

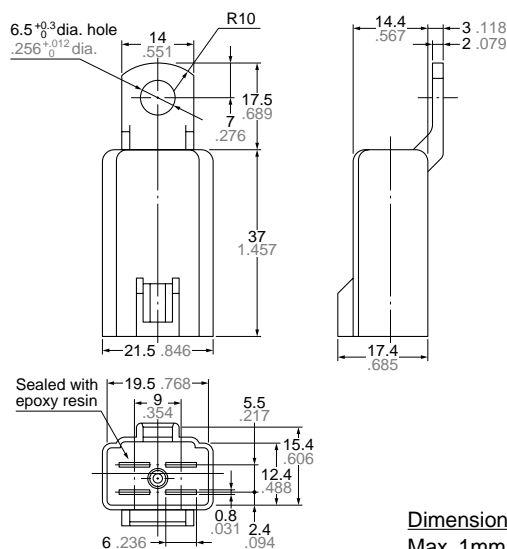

SCHMATIC (Bottom View)

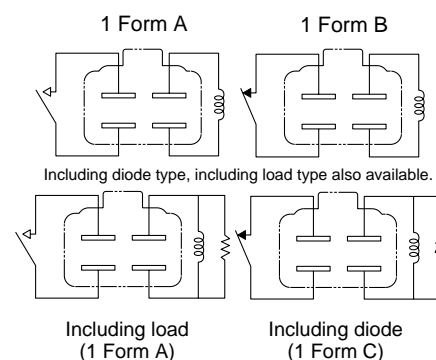

**Dimension:**  
 Max. 1mm .039 inch:  
 1 to 3mm .039 to .118 inch:  
 Min. 3mm .118 inch:

**General tolerance**  
 ±0.1 ±.004  
 ±0.2 ±.008  
 ±0.3 ±.012

# CA

## 3. 1 Form A/1 Form B Direct coupling type

mm inch

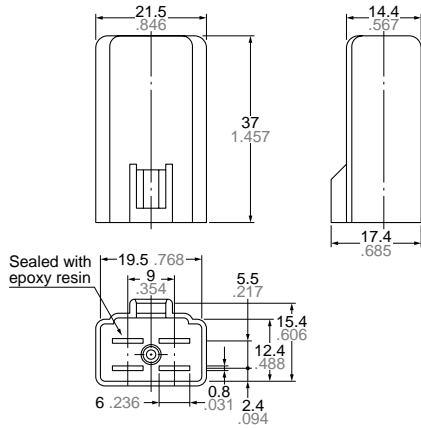

### SCHMATIC (Bottom View)

#### 1 Form A      1 Form B

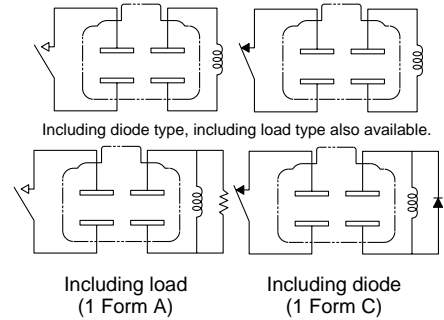

### Dimension:

Max. 1mm .039 inch:

1 to 3mm .039 to .118 inch:

Min. 3mm .118 inch:

### General tolerance

$\pm 0.1 \pm .004$

$\pm 0.2 \pm .008$

$\pm 0.3 \pm .012$

## 4. 1 Form C Screw-mounting type

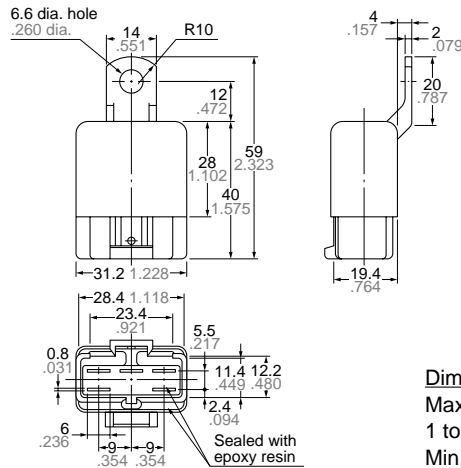

### SCHMATIC (Bottom View)

#### 1 Form C

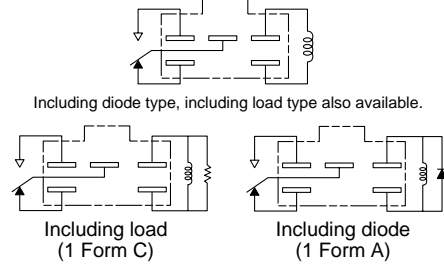

### Dimension:

Max. 1mm .039 inch:

1 to 3mm .039 to .118 inch:

Min. 3mm .118 inch:

### General tolerance

$\pm 0.1 \pm .004$

$\pm 0.2 \pm .008$

$\pm 0.3 \pm .012$

## 5. 1 Form C Direct coupling type

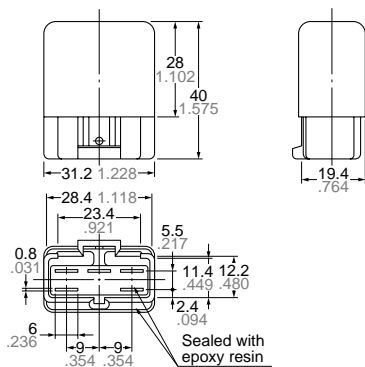

### SCHMATIC (Bottom View)

#### 1 Form C

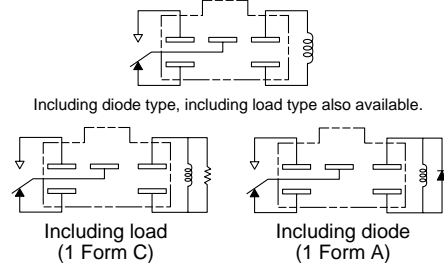

### Dimension:

Max. 1mm .039 inch:

1 to 3mm .039 to .118 inch:

Min. 3mm .118 inch:

### General tolerance

$\pm 0.1 \pm .004$

$\pm 0.2 \pm .008$

$\pm 0.3 \pm .012$

## REFERENCE DATA

### 1. Coil temperature rise

Tested sample: CA1aS-12V-N-5, 5 pcs.

Point measured: Inside the coil

Contact carrying current: 20A

Ambient temperature: Room temperature,

85°C 185°F

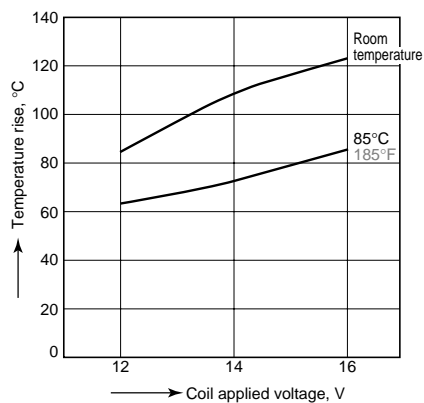

### 2. Electrical life test (Motor load)

Tested sample: CA1a-12V-N-5, 5 pcs.

Load: Steady 30A, Inrush 150A, 12V DC

Operate frequency: ON 3s, OFF 15s

Ambient temperature: Room temperature

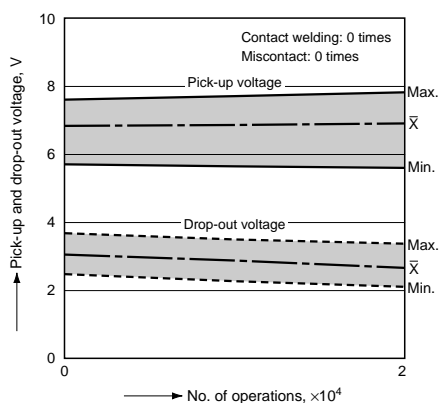

**For Cautions for use, see Relay Technical Information (Page 48 to 76).**

Компания «Океан Электроники» предлагает заключение долгосрочных отношений при поставках импортных электронных компонентов на взаимовыгодных условиях!

Наши преимущества:

- Поставка оригинальных импортных электронных компонентов напрямую с производств Америки, Европы и Азии, а так же с крупнейших складов мира;
- Широкая линейка поставок активных и пассивных импортных электронных компонентов (более 30 млн. наименований);
- Поставка сложных, дефицитных, либо снятых с производства позиций;
- Оперативные сроки поставки под заказ (от 5 рабочих дней);
- Экспресс доставка в любую точку России;
- Помощь Конструкторского Отдела и консультации квалифицированных инженеров;
- Техническая поддержка проекта, помощь в подборе аналогов, поставка прототипов;
- Поставка электронных компонентов под контролем ВП;
- Система менеджмента качества сертифицирована по Международному стандарту ISO 9001;
- При необходимости вся продукция военного и аэрокосмического назначения проходит испытания и сертификацию в лаборатории (по согласованию с заказчиком);
- Поставка специализированных компонентов военного и аэрокосмического уровня качества (Xilinx, Altera, Analog Devices, Intersil, Interpoint, Microsemi, Actel, Aeroflex, Peregrine, VPT, Syfer, Eurofarad, Texas Instruments, MS Kennedy, Miteq, Cobham, E2V, MA-COM, Hittite, Mini-Circuits, General Dynamics и др.);

Компания «Океан Электроники» является официальным дистрибьютором и эксклюзивным представителем в России одного из крупнейших производителей разъемов военного и аэрокосмического назначения «JONHON», а так же официальным дистрибьютором и эксклюзивным представителем в России производителя высокотехнологичных и надежных решений для передачи СВЧ сигналов «FORSTAR».



## JONHON

«JONHON» (основан в 1970 г.)

Разъемы специального, военного и аэрокосмического назначения:

(Применяются в военной, авиационной, аэрокосмической, морской, железнодорожной, горно- и нефтедобывающей отраслях промышленности)

«FORSTAR» (основан в 1998 г.)

ВЧ соединители, коаксиальные кабели,  
кабельные сборки и микроволновые компоненты:

(Применяются в телекоммуникациях гражданского и специального назначения, в средствах связи, РЛС, а так же военной, авиационной и аэрокосмической отраслях промышленности).



Телефон: 8 (812) 309-75-97 (многоканальный)

Факс: 8 (812) 320-03-32

Электронная почта: [ocean@oceanchips.ru](mailto:ocean@oceanchips.ru)

Web: <http://oceanchips.ru/>

Адрес: 198099, г. Санкт-Петербург, ул. Калинина, д. 2, корп. 4, лит. А