

# TACT Switch™ 5.2mm Square Low-profile (Surface Mount Type)

## SKQG Series

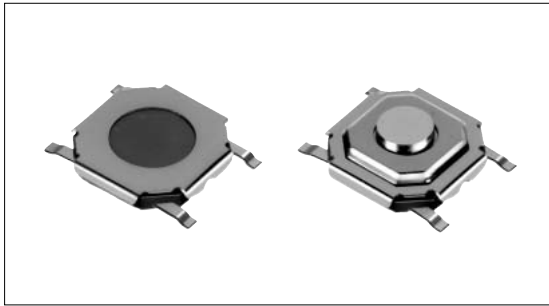

Available in two types - 0.8mm height without stem or 1.5mm height with stem.



- Detector
- Push
- Slide
- Rotary
- Encoders
- Power

Dual-in-line  
Package Type

TACT Switch™

Custom-  
Products

Sharp  
Feeling

Soft  
Feeling

Snap-in  
Type

Surface  
Mount Type

Radial  
Type

### Product Line

Product No.	Operating force	Operating direction	Travel (mm)	Rating (max.)	Rating (min.)	Operating life (5mA 5V DC)	Initial contact resistance	Variety	Minimum order unit (pcs.)	Drawing No.
SKQGAAE010	0.98N	Vertical	0.25	50mA 12V DC	10μA 1V DC	500,000cycles	100m max.	Without stem	5,000	1
SKQGAAE010	1.57N									
SKQGACE010	2.55N									
SKQGAFE010	0.98N									
SKQGAFE010	1.57N					With stem		4,000	2	
SKQGADE010	2.55N									
SKQGADE010	2.55N									
SKQGAKE010	3.43N									

### Specification of Embossed Taping Package (Taping Packaging for Auto-insertion)

Reel Size Unit:mm

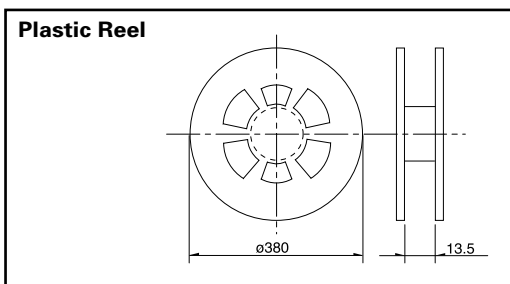

Series	Number of packages( pcs. )			Tape width ( mm )
	1 reel	1 case /Japan	1 case /export packing	
SKQGAA SKQGAC SKQGAE	5,000	50,000	50,000	12
SKQGAB SKQGAD SKQGAFA SKQGAKE	4,000	40,000	40,000	

### Note

1. Please place purchase orders for taping products per minimum order unit (1 reel or a case).
2. For 330mm diameter reel requirements, please contact us.

Refer to P.306 for soldering conditions.

**Dimensions**

Unit:mm

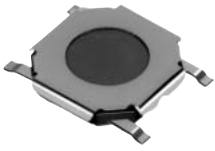
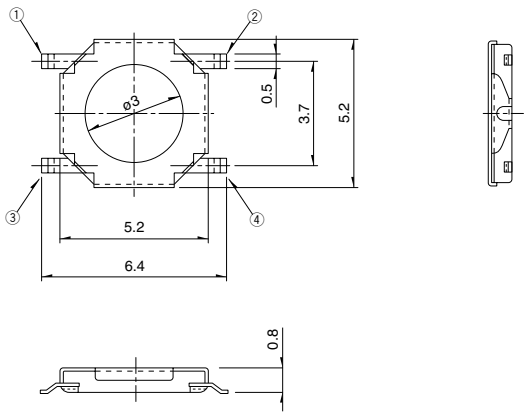
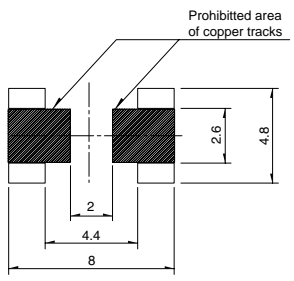
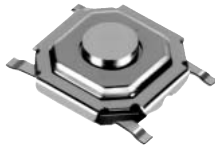
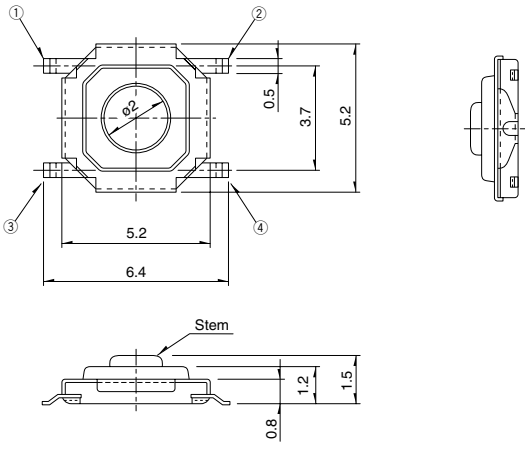
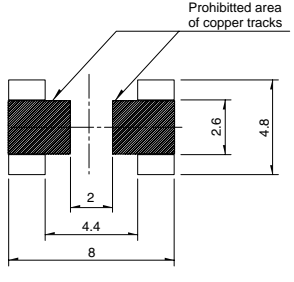
No.	Photo	Style	PC board mounting hole dimensions (Viewed from switch mounting face)
1	<p><b>Without stem type</b></p> 		
2	<p><b>With stem type</b></p> 		

- Detector
- Push
- Slide
- Rotary
- Encoders
- Power
- Dual-in-line  
Package Type
- TACT Switch™
- Custom-  
Products

- Sharp  
Feeling
- Soft  
Feeling
- Snap-in  
Type
- Surface  
Mount Type
- Radial  
Type

**Circuit Diagram**

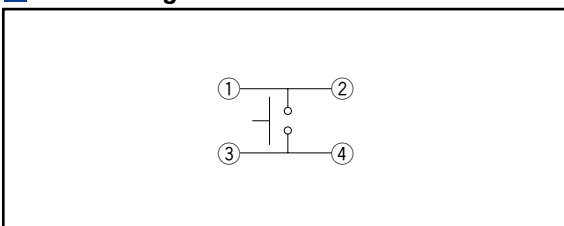

## List of Varieties

### Sharp Feeling Type

Series	SKQU	SKQB	SKQE	SKHC	SKHK	SKRW	SKRM	SKQR	SKRB	SKRR	SKQG	
Detector	<b>Photo</b>											
Push	<b>Type</b> Snap-in					Surface mount						
Slide	<b>Features</b> 4-direction switch + push switch		Water-proof Horizontal type	Long Life		Long Stem	Low-profile			Low-profile and long life	Low-profile	
Rotary	<b>Operating direction</b>	<b>Vertical</b>										
Encoders		<b>Horizontal</b>										
Power	<b>Dimensions (mm)</b>	<b>W</b>	10	11.5	12		3.7	4.5	4.8		7.5	5.2
Dual-in-line Package Type		<b>D</b>		11.9							7	
TACT Switch™		<b>H</b>	7.1	11.3	4.3		12	0.35	0.4	0.5	0.55	0.6
Custom-Products	<b>Operation force coverage</b>		1N	See the relevant pages for respective product descriptions	•	↕	↕	•	↕	↕	↕	↕
			5N									
	<b>Ground terminal</b>											
	<b>Operating temperature range</b> -30 to +85											
Sharp Feeling	<b>Electrical performance</b>	<b>Insulation resistance</b>	100M min. 100V DC									
Soft Feeling		<b>Voltage proof</b>	250V AC for 1min. SKRW/RM/RB/RR : 100V AC for 1min.									
Snap-in Type	<b>Durability</b>	<b>Vibration</b>	10 to 55 to 10Hz/min., the amplitude is 1.5mm for all the frequencies, in the 3 direction of X, Y and Z for 2hours respectively									
Surface Mount Type		<b>Lifetime</b>	Shall be in accordance with individual specifications.									
Radial Type	<b>Environmental performance</b>	<b>Cold</b>	-30 ± 2 for 96h									
		<b>Dry heat</b>	80 ± 2 for 96h									
		<b>Damp heat</b>	60 ± 2 , 90 to 95%RH for 96h									
	<b>Page</b>	482	265	267	268	270	271	272	273	274	275	276

W : Width. The most outer dimension excluding terminal portion.  
 D : Depth. The most outer dimension excluding terminal portion.  
 H : Height. The minimum dimension if there are variances.

TACT Switch™ Soldering Conditions .....306  
 TACT Switch™ Cautions .....307  
 Product Line of Knob for TACT Switch™ .....308

**Note**

The automotive operating temperature range to be individually discussed upon request.

## Soldering Conditions

### Condition for Reflow

Available for Surface Mount Type.

1. Heating method: Double heating method with infrared heater.
2. Temperature measurement: Thermocouple 0.1 to 0.2 CA(K) or CC(T) at solder joints( copper foil surface ). A heat resistive tape should be used to fix thermocouple.
3. Temperature profile

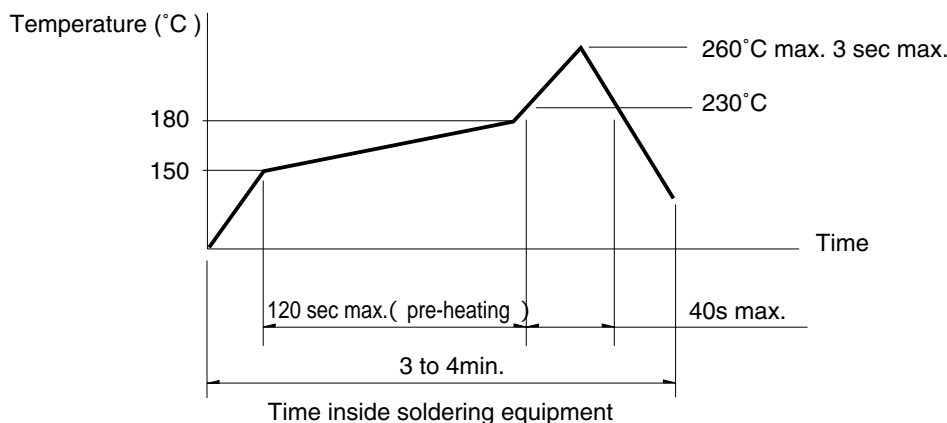

### Note

1. The above temperature shall be measured on the mounting surface of a PC board. There are cases where the PC board's temperature greatly differs from that of the switch, depending on the material, size, thickness of PC boards and others. The above-stated conditions shall also apply to switch surface temperatures.
2. Soldering conditions differ depending on reflow soldering machines. Prior verification of soldering condition is highly recommended.

### Conditions for Auto-dip

Available for Snap-in Type and Radial Type  
(Except SKHJ, SKHL, SKQJ, SKQK, SKEG series)

Items	Condition
Flux built-up	Mounting surface should not be exposed to flux
Preheating temperature	Ambient temperature of the soldered surface of PC board. 100 max.
Preheating time	60s max.
Soldering temperature	260 max.
Duration of immersion	5s max.
Number of soldering	2times max.

### Manual Soldering ( Except SKRT Series )

Items	Condition
Soldering temperature	350 max.
Duration of soldering	3s max.
Capacity of soldering iron	60W max.

### Notes

1. Consult with us for availability of TACT Switch™ washing.
2. Prevent flux penetration from the top side of the TACT Switch™.
3. Switch terminals and a PC board should not be coated with flux prior to soldering.
4. The second soldering should be done after the switch is stable with normal temperature.
5. Use the flux with a specific gravity of min 0.81.  
( EC-19S-8 by TAMURA Corporation, or equivalents. )

Detector  
Push  
Slide  
Rotary  
Encoders  
Power  
Dual-in-line Package Type  
TACT Switch™  
Custom-Products

Sharp Feeling  
Soft Feeling  
Snap-in Type  
Surface Mount Type  
Radial Type

Компания «Океан Электроники» предлагает заключение долгосрочных отношений при поставках импортных электронных компонентов на взаимовыгодных условиях!

Наши преимущества:

- Поставка оригинальных импортных электронных компонентов напрямую с производств Америки, Европы и Азии, а так же с крупнейших складов мира;
- Широкая линейка поставок активных и пассивных импортных электронных компонентов (более 30 млн. наименований);
- Поставка сложных, дефицитных, либо снятых с производства позиций;
- Оперативные сроки поставки под заказ (от 5 рабочих дней);
- Экспресс доставка в любую точку России;
- Помощь Конструкторского Отдела и консультации квалифицированных инженеров;
- Техническая поддержка проекта, помощь в подборе аналогов, поставка прототипов;
- Поставка электронных компонентов под контролем ВП;
- Система менеджмента качества сертифицирована по Международному стандарту ISO 9001;
- При необходимости вся продукция военного и аэрокосмического назначения проходит испытания и сертификацию в лаборатории (по согласованию с заказчиком);
- Поставка специализированных компонентов военного и аэрокосмического уровня качества (Xilinx, Altera, Analog Devices, Intersil, Interpoint, Microsemi, Actel, Aeroflex, Peregrine, VPT, Syfer, Eurofarad, Texas Instruments, MS Kennedy, Miteq, Cobham, E2V, MA-COM, Hittite, Mini-Circuits, General Dynamics и др.);

Компания «Океан Электроники» является официальным дистрибьютором и эксклюзивным представителем в России одного из крупнейших производителей разъемов военного и аэрокосмического назначения «**JONHON**», а так же официальным дистрибьютором и эксклюзивным представителем в России производителя высокотехнологичных и надежных решений для передачи СВЧ сигналов «**FORSTAR**».



## JONHON

«**JONHON**» (основан в 1970 г.)

Разъемы специального, военного и аэрокосмического назначения:

(Применяются в военной, авиационной, аэрокосмической, морской, железнодорожной, горно- и нефтедобывающей отраслях промышленности)

«**FORSTAR**» (основан в 1998 г.)

ВЧ соединители, коаксиальные кабели,  
кабельные сборки и микроволновые компоненты:

(Применяются в телекоммуникациях гражданского и специального назначения, в средствах связи, РЛС, а так же военной, авиационной и аэрокосмической отраслях промышленности).



Телефон: 8 (812) 309-75-97 (многоканальный)

Факс: 8 (812) 320-03-32

Электронная почта: [ocean@oceanchips.ru](mailto:ocean@oceanchips.ru)

Web: <http://oceanchips.ru/>

Адрес: 198099, г. Санкт-Петербург, ул. Калинина, д. 2, корп. 4, лит. А