

**LOW-POWER OFF-LINE PRIMARY SIDE REGULATION CONTROLLER AP3766****General Description**

The AP3766 is a high performance AC/DC power supply controller for battery charger and adapter applications. The device uses Pulse Frequency Modulation (PFM) method to build discontinuous conduction mode (DCM) flyback power supplies.

The AP3766 provides accurate constant voltage, constant current (CV/CC) regulation while removing the opto-coupler and secondary control circuitry. It also eliminates the need of loop compensation circuitry while maintaining stability. The AP3766 achieves excellent regulation and high average efficiency, yet meets the requirement for no-load consumption less than 30mW.

The AP3766 is available in SOT-23-6 package.

Features

- Primary Side Control for Rectangular Constant Current and Constant Voltage Output
- Sub-microampere Start-up Current
- 30mW No-load Input Power Feasible
- Tight CC Regulation Performance
- Eliminates Opto-coupler and Secondary CV/CC Control Circuitry
- Eliminates Control Loop Compensation Circuitry
- Flyback Topology in DCM Operation
- Random Frequency Modulation to Reduce System EMI
- Built-in Soft Start
- Open Feedback Protection
- Short Circuit Protection
- SOT-23-6 Package

Applications

- Adapters/Chargers for Cell/Cordless Phones, PDAs, MP3 and Other Portable Apparatus
- LED Drivers
- Standby and Auxiliary Power Supplies

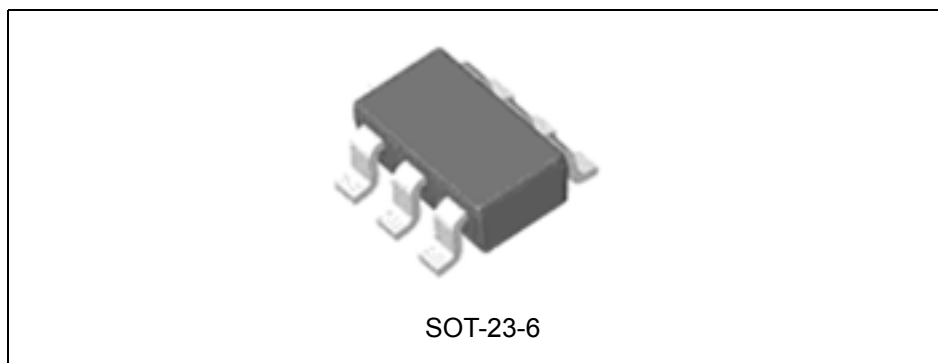

Figure 1. Package Type of AP3766

LOW-POWER OFF-LINE PRIMARY SIDE REGULATION CONTROLLER AP3766

Pin Configuration

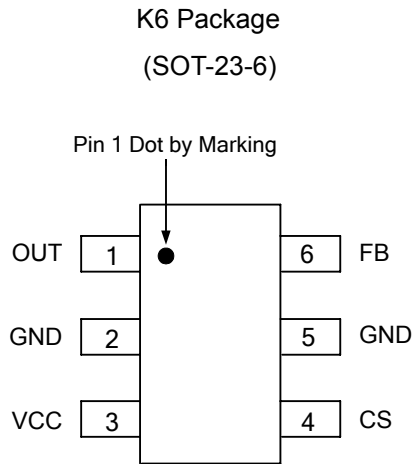

Figure 2. Pin Configuration of AP3766 (Top View)

Pin Description

Pin Number	Pin Name	Function
1	OUT	This pin drives the base of external power NPN switch
2, 5	GND	Ground
3	VCC	Supply voltage
4	CS	The primary current sense
6	FB	The voltage feedback from the auxiliary winding



LOW-POWER OFF-LINE PRIMARY SIDE REGULATION CONTROLLER AP3766

Functional Block Diagram

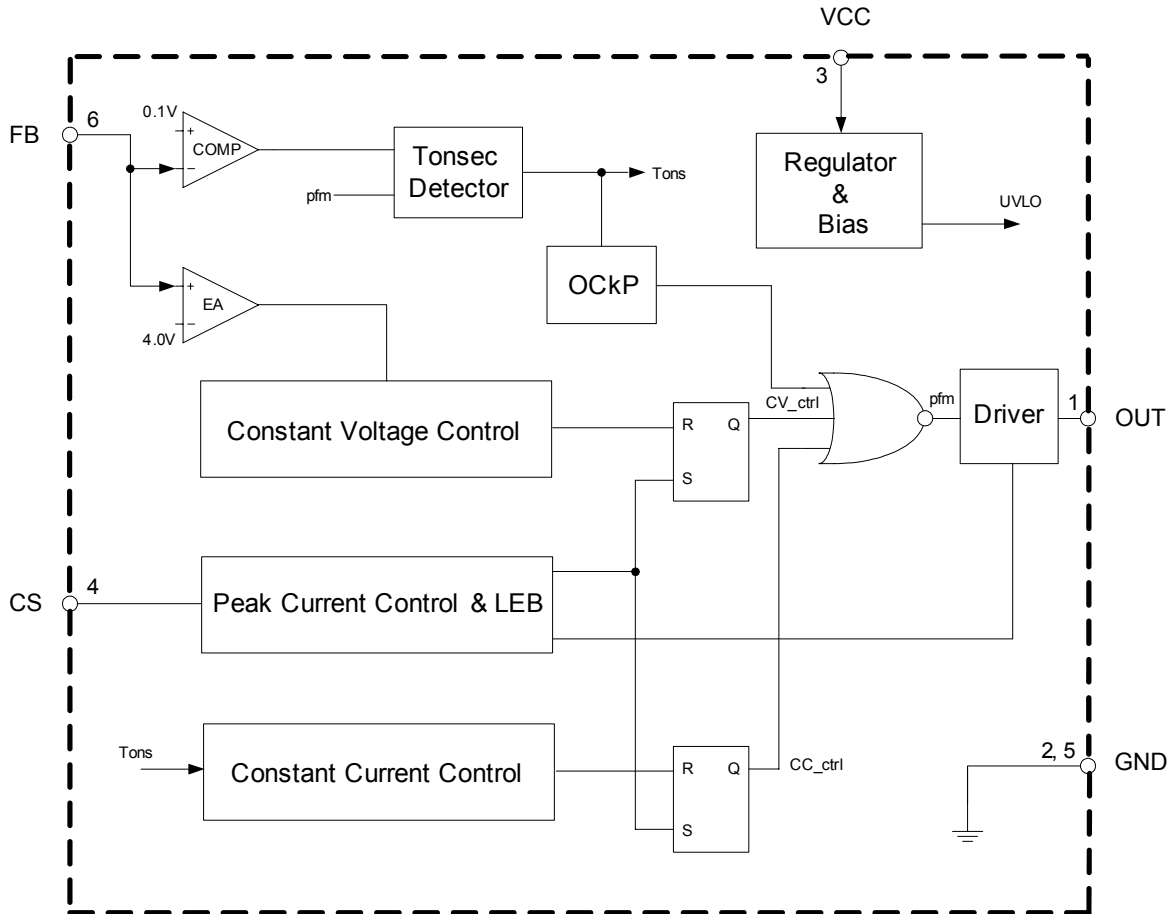
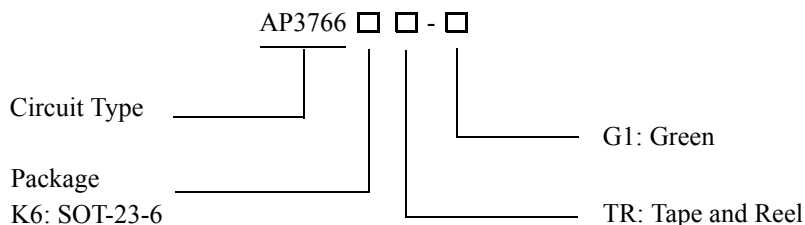

Figure 3. Functional Block Diagram of AP3766

**LOW-POWER OFF-LINE PRIMARY SIDE REGULATION CONTROLLER AP3766****Ordering Information**

Package	Temperature Range	Part Number	Marking ID	Packing Type
SOT-23-6	-40 to 85°C	AP3766K6TR-G1	GBF	Tape & Reel

BCD Semiconductor's products, as designated with "G1" suffix in the part number, are RoHS compliant and Green.

Absolute Maximum Ratings (Note 1)

Parameter	Value	Unit
Supply Voltage VCC	-0.3 to 36	V
Voltage at CS, OUT to GND	-0.3 to 7	V
FB Input	-40 to 10	V
Output Current at OUT	Internally limited	A
Operating Junction Temperature	150	°C
Storage Temperature	-65 to 150	°C
Lead Temperature (Soldering, 10s)	300	°C
Thermal Resistance Junction-to-Ambient	250	°C/W
ESD (Machine Model)	200	V
ESD (Human Body Model)	2000	V

Note 1: Stresses greater than those listed under "Absolute Maximum Ratings" may cause permanent damage to the device. These are stress ratings only, and functional operation of the device at these or any other conditions beyond those indicated under "Recommended Operating Conditions" is not implied. Exposure to "Absolute Maximum Ratings" for extended periods may affect device reliability.



LOW-POWER OFF-LINE PRIMARY SIDE REGULATION CONTROLLER AP3766

Electrical Characteristics

($V_{CC}=15V$, $T_A=25^{\circ}C$, unless otherwise specified.)

Parameter	Symbol	Conditions	Min	Typ	Max	Unit
UVLO SECTION						
Start-up Threshold	$V_{TH(ST)}$		16	18.5	21	V
Minimal Operating Voltage	$V_{OPR(min)}$		7.2	9	10.2	V
STANDBY CURRENT SECTION						
Start-up Current	I_{ST}	$V_{CC} = V_{TH(ST)} - 0.5V$, Before start-up			0.6	μA
Operating Current	$I_{CC(OPR)}$	Static		200	320	μA
DRIVE OUTPUT SECTION						
OUT Maximum Current	Sink	I_{OUT}	50			mA
	Source		24	30	36	
CURRENT SENSE SECTION						
Current Sense Threshold	V_{CS}		455	510	545	mV
Pre-Current Sense	$V_{CS(PRE)}$		365	410	455	mV
Leading Edge Blanking				750		ns
FEEDBACK INPUT SECTION						
Feedback Pin Input Leakage Current	I_{FB}	$V_{FB}=4V$	2.0	2.5	3.1	μA
Feedback Threshold	V_{FB}		3.59	3.83	4.07	V



LOW-POWER OFF-LINE PRIMARY SIDE REGULATION CONTROLLER AP3766

Typical Performance Characteristics

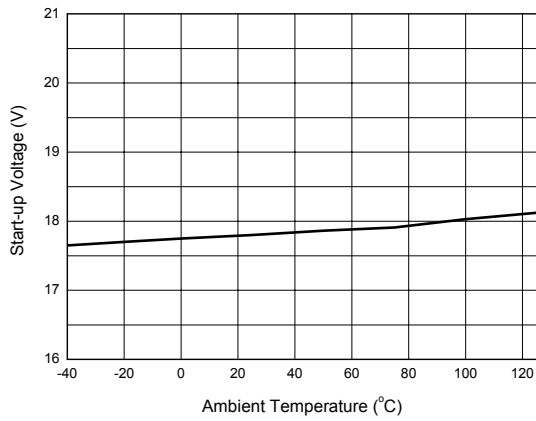

Figure 4. Start-up Voltage vs. Ambient Temperature

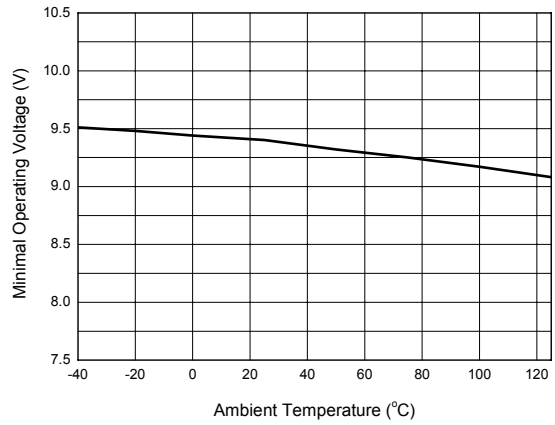

Figure 5. Minimal Operating Voltage vs. Ambient Temperature

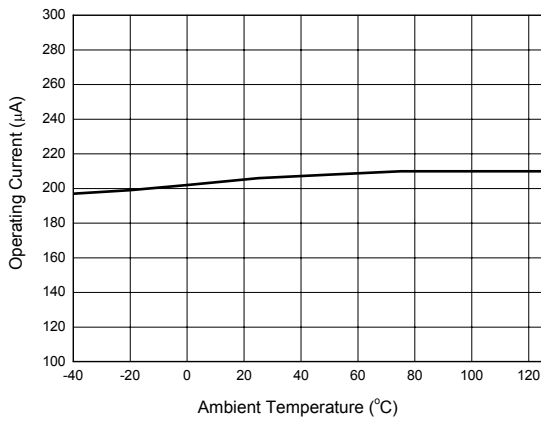

Figure 6. Operating Current vs. Ambient Temperature

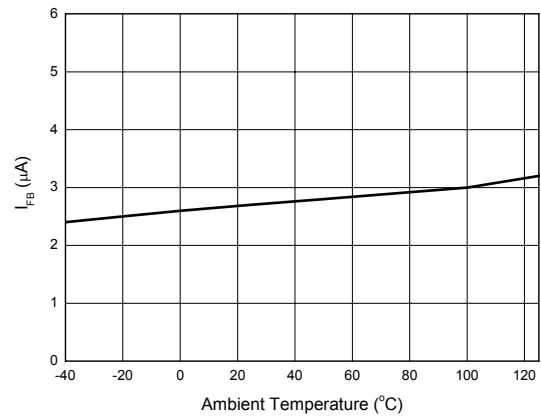

Figure 7. I_{FB} vs. Ambient Temperature

Typical Application

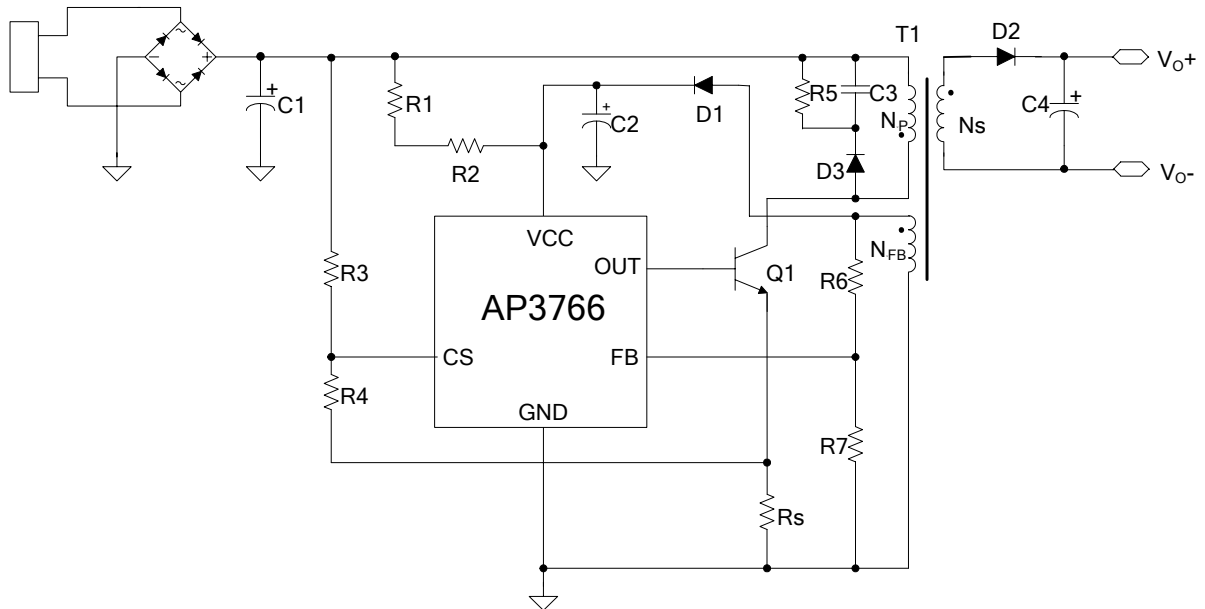

Figure 8. 5V/700mA Output for Battery Charger of Mobile Phone



LOW-POWER OFF-LINE PRIMARY SIDE REGULATION CONTROLLER AP3766

Mechanical Dimensions

SOT-23-6

Unit: mm(inch)

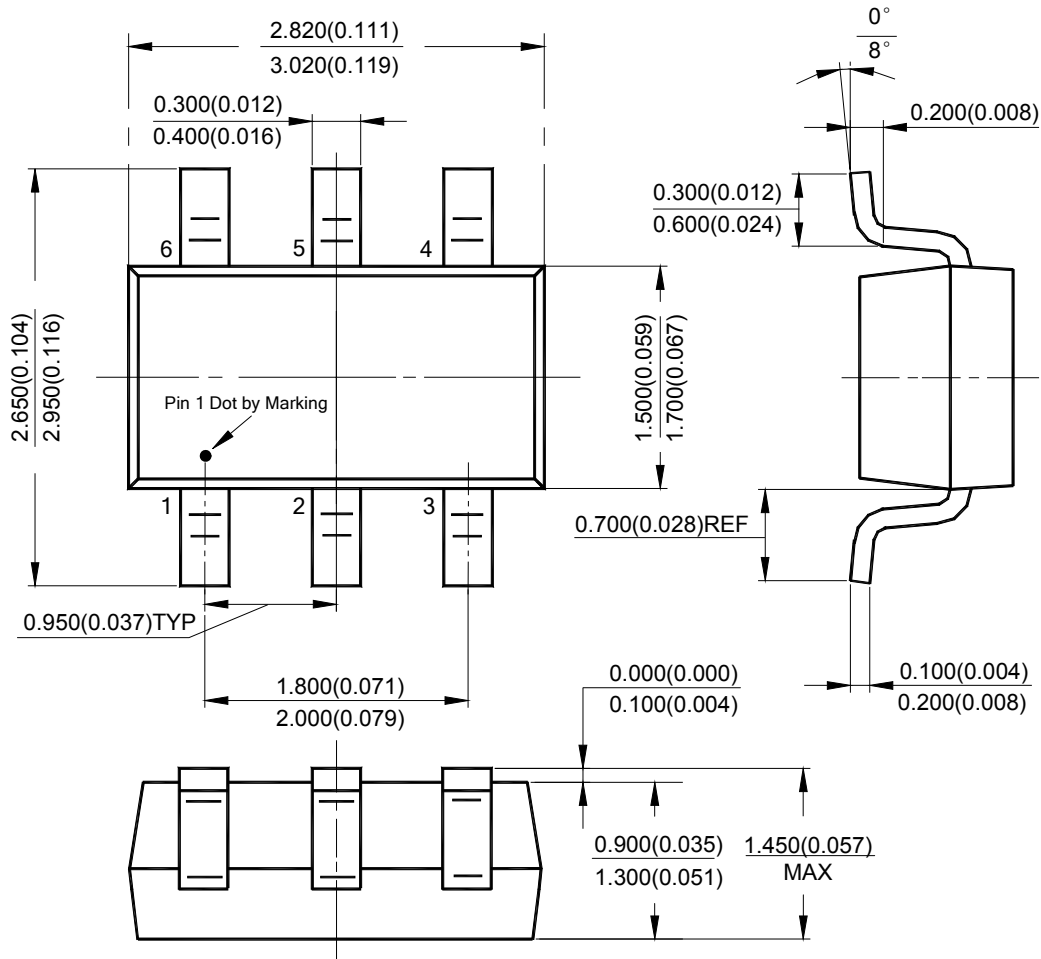



BCD Semiconductor Manufacturing Limited

<http://www.bcdsemi.com>

IMPORTANT NOTICE

BCD Semiconductor Manufacturing Limited reserves the right to make changes without further notice to any products or specifications herein. BCD Semiconductor Manufacturing Limited does not assume any responsibility for use of any its products for any particular purpose, nor does BCD Semiconductor Manufacturing Limited assume any liability arising out of the application or use of any its products or circuits. BCD Semiconductor Manufacturing Limited does not convey any license under its patent rights or other rights nor the rights of others.

MAIN SITE

- Headquarters

BCD Semiconductor Manufacturing Limited

No. 1600, Zi Xing Road, Shanghai Zizhu Science-based Industrial Park, 200241, China
Tel: +86-21-24162266, Fax: +86-21-24162277

- Wafer Fab

Shanghai SIM-BCD Semiconductor Manufacturing Co., Ltd.

800 Yi Shan Road, Shanghai 200233, China
Tel: +86-21-6485 1491, Fax: +86-21-5450 0008

REGIONAL SALES OFFICE

Shenzhen Office

Shanghai SIM-BCD Semiconductor Manufacturing Co., Ltd., Shenzhen Office

Unit A Room 1203, Skyworth Bldg., Gaoxin Ave. 1.S., Nanshan District, Shenzhen, China
Tel: +86-755-8826 7951
Fax: +86-755-8826 7865

Taiwan Office

BCD Semiconductor (Taiwan) Company Limited

4F, 298-1, Rui Guang Road, Nei-Hu District, Taipei, Taiwan
Tel: +886-2-2656 2808
Fax: +886-2-2656 2806

USA Office

BCD Semiconductor Corp.

30920 Huntwood Ave. Hayward, CA 94544, USA
Tel : +1-510-324-2988
Fax: +1-510-324-2788

Компания «Океан Электроники» предлагает заключение долгосрочных отношений при поставках импортных электронных компонентов на взаимовыгодных условиях!

Наши преимущества:

- Поставка оригинальных импортных электронных компонентов напрямую с производств Америки, Европы и Азии, а так же с крупнейших складов мира;
- Широкая линейка поставок активных и пассивных импортных электронных компонентов (более 30 млн. наименований);
- Поставка сложных, дефицитных, либо снятых с производства позиций;
- Оперативные сроки поставки под заказ (от 5 рабочих дней);
- Экспресс доставка в любую точку России;
- Помощь Конструкторского Отдела и консультации квалифицированных инженеров;
- Техническая поддержка проекта, помощь в подборе аналогов, поставка прототипов;
- Поставка электронных компонентов под контролем ВП;
- Система менеджмента качества сертифицирована по Международному стандарту ISO 9001;
- При необходимости вся продукция военного и аэрокосмического назначения проходит испытания и сертификацию в лаборатории (по согласованию с заказчиком);
- Поставка специализированных компонентов военного и аэрокосмического уровня качества (Xilinx, Altera, Analog Devices, Intersil, Interpoint, Microsemi, Actel, Aeroflex, Peregrine, VPT, Syfer, Eurofarad, Texas Instruments, MS Kennedy, Miteq, Cobham, E2V, MA-COM, Hittite, Mini-Circuits, General Dynamics и др.);

Компания «Океан Электроники» является официальным дистрибьютором и эксклюзивным представителем в России одного из крупнейших производителей разъемов военного и аэрокосмического назначения «JONHON», а так же официальным дистрибьютором и эксклюзивным представителем в России производителя высокотехнологичных и надежных решений для передачи СВЧ сигналов «FORSTAR».



JONHON

«JONHON» (основан в 1970 г.)

Разъемы специального, военного и аэрокосмического назначения:

(Применяются в военной, авиационной, аэрокосмической, морской, железнодорожной, горно- и нефтедобывающей отраслях промышленности)

«FORSTAR» (основан в 1998 г.)

ВЧ соединители, коаксиальные кабели, кабельные сборки и микроволновые компоненты:

(Применяются в телекоммуникациях гражданского и специального назначения, в средствах связи, РЛС, а так же военной, авиационной и аэрокосмической отраслях промышленности).



Телефон: 8 (812) 309-75-97 (многоканальный)

Факс: 8 (812) 320-03-32

Электронная почта: ocean@oceanchips.ru

Web: <http://oceanchips.ru/>

Адрес: 198099, г. Санкт-Петербург, ул. Калинина, д. 2, корп. 4, лит. А