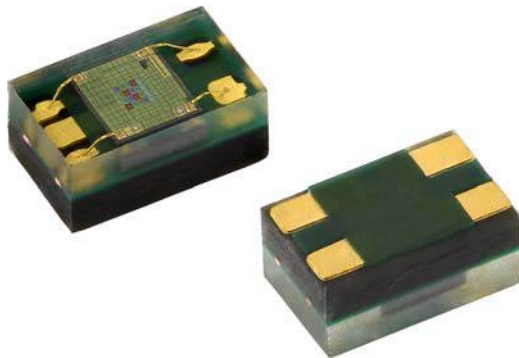


RGBW Color Sensor with I²C Interface



DESCRIPTION

VEML6040 color sensor senses red, green, blue, and white light and incorporates photodiodes, amplifiers, and analog / digital circuits into a single chip using CMOS process. With the color sensor applied, the brightness, and color temperature of backlight can be adjusted base on ambient light source that makes panel looks more comfortable for end user's eyes. VEML6040's adoption of Filtron™ technology achieves the closest ambient light spectral sensitivity to real human eye responses.

VEML6040 provides excellent temperature compensation capability for keeping the output stable under changing temperature. VEML6040's function are easily operated via the simple command format of I²C (SMBus compatible) interface protocol. VEML6040's operating voltage ranges from 2.5 V to 3.6 V. VEML6040 is packaged in a lead (Pb)-free 4 pin OPLGA package which offers the best market-proven reliability.

FEATURES

- Package type: surface mount
- Dimensions (L x W x H in mm): 2.0 x 1.25 x 1.0
- Integrated modules: color sensor (RGBW) and signal conditioning IC
- Filtron™ technology provides a spectrum matching real human eye responses
- Supports low transmittance (dark) lens design
- Fluorescent light flicker immunity
- Provides 16-bit resolution for each channel (R, G, B, W)
- Selectable maximum detection range (360, 721, 1442, 2883, 5767, or 11 796) lux with highest sensitivity 0.0056 lux/step
- Package: OPLGA
- Temperature compensation: -40 °C to +85 °C
- Low power consumption I²C (SMBus compatible) interface
- Floor life: 168 h, MSL 3, according to J-STD-020
- Output type: I²C bus
- Operation voltage: 2.5 V to 3.6 V
- Material categorization: for definitions of compliance please see www.vishay.com/doc?99912



APPLICATIONS

- Handheld device
- Notebook
- Consumer device
- Industrial and mechanical application

PRODUCT SUMMARY					
PART NUMBER	OPERATING VOLTAGE RANGE (V)	I ² C BUS VOLTAGE RANGE (V)	PEAK SENSITIVITY (nm)	RANGE OF SPECTRAL BANDWIDTH λ _{0.5} (nm)	OUTPUT CODE
VEML6040	2.5 to 3.6	1.7 to 3.6	650, 550, 450 (R, G, B)	± 35, ± 35, ± 40 (R, G, B)	16 bit, I ² C

Note

(1) Adjustable through I²C interface

ORDERING INFORMATION			
ORDERING CODE	PACKAGING	VOLUME (1)	REMARKS
VEML6040A30G	Tape and reel	MOQ: 2500 pcs	2.0 mm x 1.25 mm x 1.0 mm

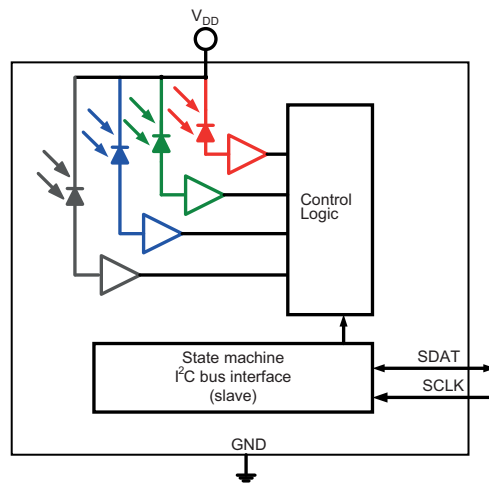
Note

(1) MOQ: minimum order quantity

ABSOLUTE MAXIMUM RATINGS (T _{amb} = 25 °C, unless otherwise specified)					
PARAMETER	TEST CONDITION	SYMBOL	MIN.	MAX.	UNIT
Supply voltage		V _{DD}	0	3.6	V
Operation temperature range		T _{amb}	-40	+85	°C
Storage temperature range		T _{stg}	-40	+85	°C

RECOMMENDED OPERATING CONDITIONS ($T_{amb} = 25\text{ }^{\circ}\text{C}$, unless otherwise specified)					
PARAMETER	TEST CONDITION	SYMBOL	MIN.	MAX.	UNIT
Supply voltage		V_{DD}	2.5	3.6	V
Operation temperature range		T_{amb}	-40	+85	$^{\circ}\text{C}$
I ² C bus operating frequency		$f_{(I2CCLK)}$	10	400	kHz

PIN DESCRIPTIONS			
PIN ASSIGNMENT	SYMBOL	TYPE	FUNCTION
1	GND	I	Ground
2	SDAT	I / O (open drain)	I ² C data bus data input / output
3	SCLK	I	I ² C digital bus clock input
4	V_{DD}	I	Power supply input

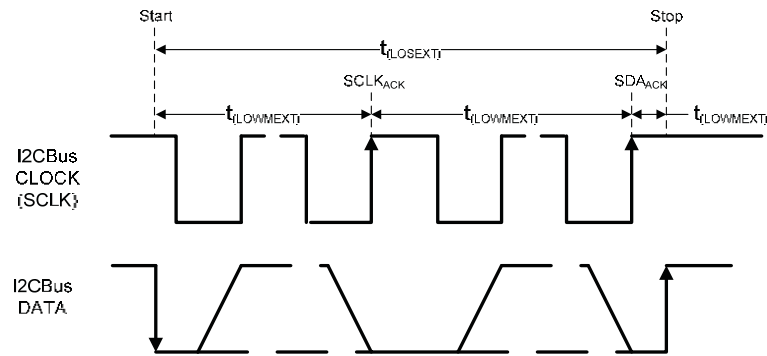
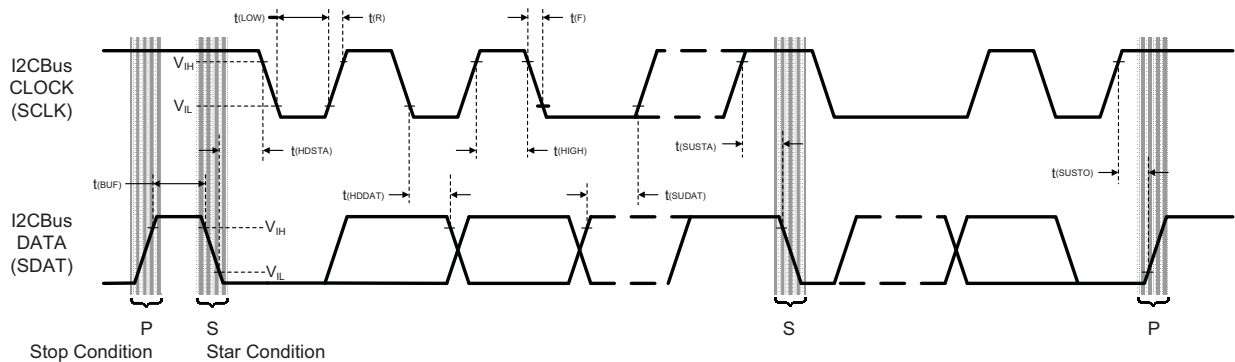
BLOCK DIAGRAM


BASIC CHARACTERISTICS ($T_{amb} = 25\text{ }^{\circ}\text{C}$, unless otherwise specified)						
PARAMETER	TEST CONDITION	SYMBOL	MIN.	TYP.	MAX.	UNIT
Supply voltage		V_{DD}	2.5		3.6	V
Supply current		I_{DD}		200		μA
I ² C signal input	Logic high	$V_{DD} = 3.3\text{ V}$	V_{IH}	1.5		V
	Logic low		V_{IL}		0.8	
	Logic high	$V_{DD} = 2.6\text{ V}$	V_{IH}	1.4		V
	Logic low		V_{IL}		0.6	
Peak sensitivity wavelength		λ_{PR}		650		nm
		λ_{PG}		550		nm
		λ_{PB}		450		nm
Irradiance responsivity	$\lambda_{PR} = 630\text{ nm}$			180		LSB/ $(\mu\text{W}/\text{cm}^2)$
	$\lambda_{PG} = 530\text{ nm}$			144		
	$\lambda_{PB} = 467\text{ nm}$			52		
Detectable intensity	Minimum	G channel, $t_T = 1280\text{ ms}$ ⁽¹⁾⁽²⁾		0.0056		lx
	Maximum	G channel, $t_T = 40\text{ ms}$ ⁽¹⁾⁽²⁾		11 796		
Dark offset		G channel, $t_T = 80\text{ ms}$ ⁽¹⁾		0	3	
Operating temperature range		T_{amb}	-40		+85	$^{\circ}\text{C}$
Shutdown current	Light condition = dark, $V_{DD} = 3.6\text{ V}$	I_{DD}		800		nA

Notes

- (1) Test condition: $V_{DD} = 3.3\text{ V}$, temperature: $25\text{ }^{\circ}\text{C}$
 (2) Light source: white LED

I²C BUS TIMING CHARACTERISTICS ($T_{amb} = 25\text{ }^{\circ}\text{C}$, unless otherwise specified)						
PARAMETER	SYMBOL	STANDARD MODE		FAST MODE		UNIT
		MIN.	MAX.	MIN.	MAX.	
Clock frequency	$f_{(SMBCLK)}$	10	100	10	400	kHz
Bus free time between start and stop condition	$t_{(BUF)}$	4.7		1.3		μs
Hold time after (repeated) start condition; after this period, the first clock is generated	$t_{(HDSTA)}$	4.0		0.6		μs
Repeated start condition setup time	$t_{(SUSTA)}$	4.7		0.6		μs
Stop condition setup time	$t_{(SUSTO)}$	4.0		0.6		μs
Data hold time	$t_{(HDDAT)}$	200		90		ns
Data setup time	$t_{(SUDAT)}$	250		100		ns
I ² C clock (SCK) low period	$t_{(LOW)}$	4.7		1.3		μs
I ² C clock (SCK) high period	$t_{(HIGH)}$	4.0		0.6		μs
Detect clock / data low timeout	$t_{(TIMEOUT)}$	25	35			ms
Clock / data fall time	$t_{(F)}$		300		300	ns
Clock / data rise time	$t_{(R)}$		1000		300	ns


 Fig. 1 - I²C Bus Timing Diagram

PARAMETER TIMING INFORMATION

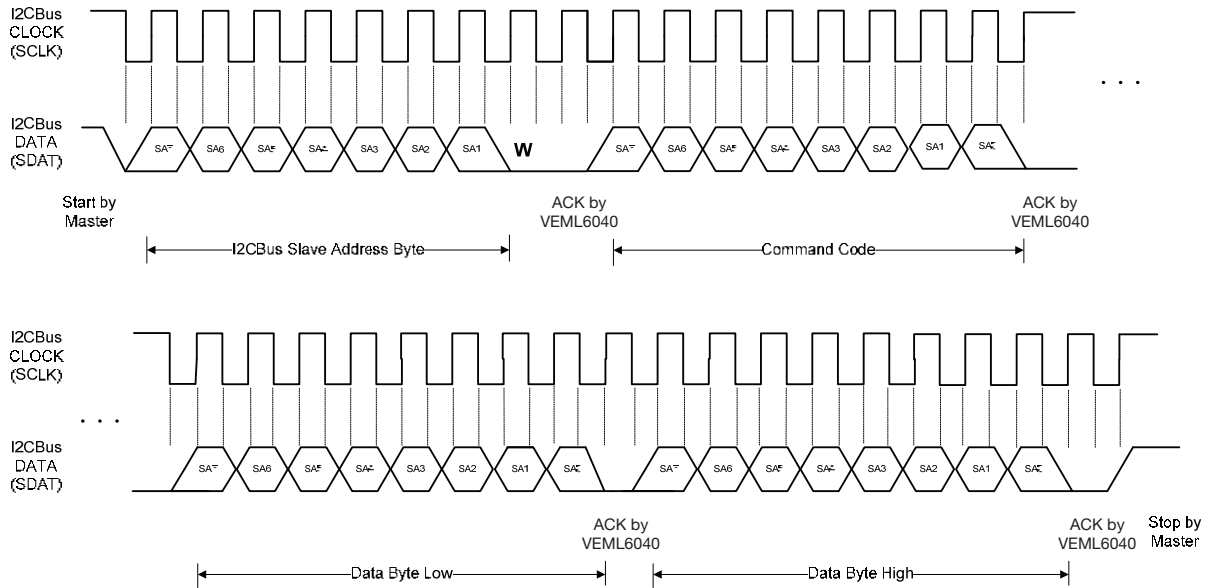


Fig. 2 - I²C Bus Timing for Sending Word Command Format

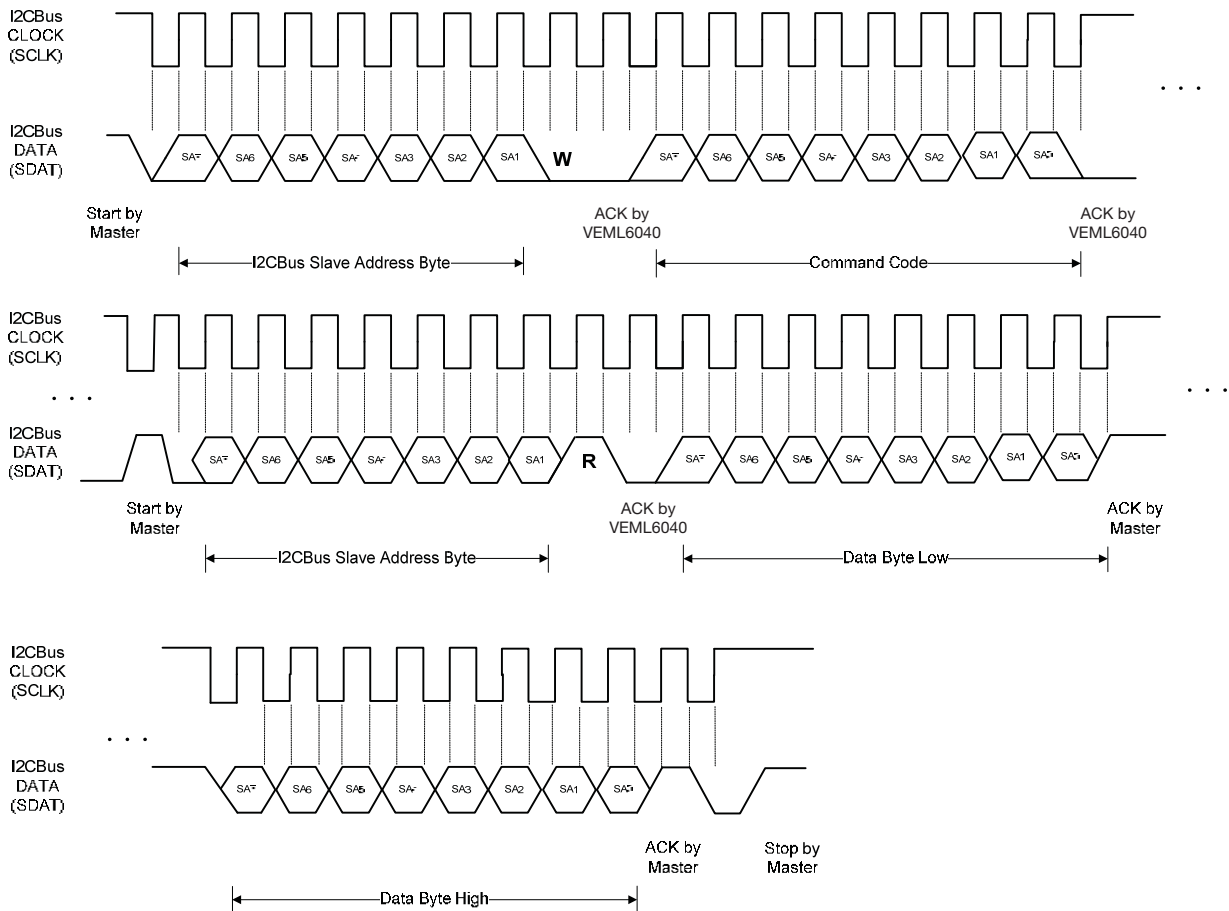


Fig. 3 - I²C Bus Timing for Receiving Word Command Format

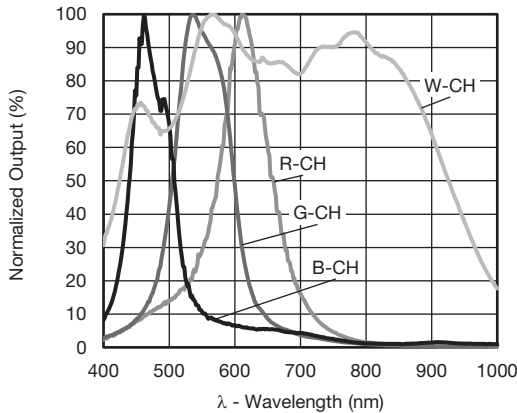
TYPICAL PERFORMANCE CHARACTERISTICS ($T_{amb} = 25\text{ }^{\circ}\text{C}$, unless otherwise specified)


Fig. 4 - Normalized Spectral Response

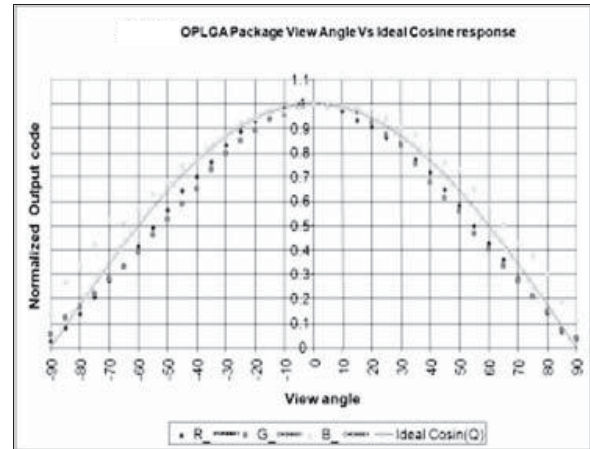


Fig. 5 - Normalized Output vs. View Angle

APPLICATION INFORMATION
Pin Connection with the Host

VEML6040 integrates R, G, B, and W sensor together with I²C interface. It is very easy for the baseband (CPU) to access VEML6040 output data via I²C interface without extra software algorithms. The hardware schematic is shown in the following diagram.

The 0.1 μF capacitor near the V_{DD} pin is used for power supply noise rejection. The 2.2 k Ω s are suitable for the pull-up resistors of I²C.

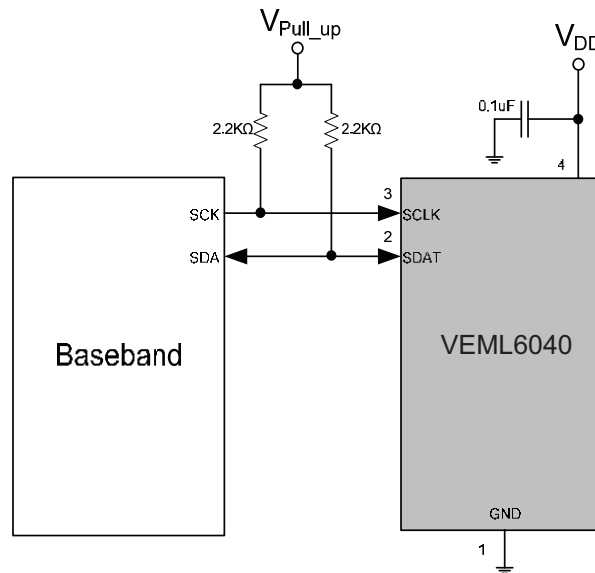


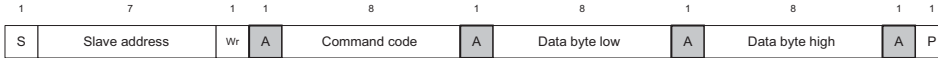
Fig. 6 - Hardware Pin Connection Diagram



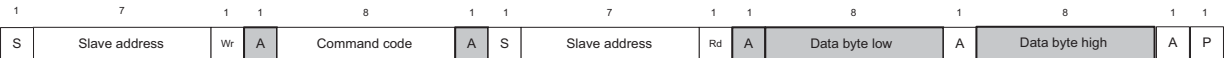
Digital Interface

VEML6040 apply slave address 0x10 of 7 bit addressing protocol for I2C. VEML6040 contains an 8-bit command register following each of slave address as shown in figure 7. All operations can be controlled by the command register. The simple command structure helps users easily program the operation setting and latch the light data from VEML6040. Following I2C command format is simple for read and write operations between VEML6040 and the host as shown in figure 7. The white sections indicate host activity and the gray sections indicate VEML6040's acknowledgement of the host access activity. Based on write word protocol, 8-bit command codes can be written by the host under the same slave address. For data reading, VEML6040 apply read word protocol.

Send Byte -> Write Command to VEML6040



Receive Byte -> Read Data from VEML6040



S = start condition
P = stop condition
A = acknowledge
Shaded area = VEML6040 acknowledge

Fig. 7 - Command Protocol Format

Slave Address and Function Description

VEML6040 uses 0x10 slave address for 7-bit I2C addressing protocol. VEML6040 has 16-bit resolution for each channel (R, G, B, and W) that provides sensitivity up to 0.0056 lux/step for G, which is advantageous under a low transmittance lens design (dark lens).

Table with 10 columns: COMMAND CODE, REGISTER NAME, R / W, BIT (7, 6, 5, 4, 3, 2, 1, 0). Rows include CONF, Reserved, R_DATA_L, R_DATA_M, G_DATA_L, G_DATA_M, B_DATA_L, B_DATA_M, W_DATA_L, W_DATA_M.

Note

- Slave address is 7-bit addressing protocol



Command Register Format

VEML6040 provides an 8-bit command register for controlling. The description of each command format is shown in the following tables. Color sensor is function compatible with ambient light sensor when apply color sensor at green channel.

Color Sensor Command

TABLE 2-1 - COMMAND CODE 00H BITS DESCRIPTION							
SLAVE ADDRESS: 0x10; REGISTER NAME: CONF; COMMAND CODE: 00H / DATA BYTE LOW							
X	IT			X	TRIG	AF	SD
BIT 7	BIT 6	BIT 5	BIT 4	BIT 3	BIT 2	BIT 1	BIT 0
0	IT2	IT1	IT0	0	TRIG	AF	SD
DESCRIPTION							
IT		Integration time setting					
TRIG		Proceed one detecting cycle at manual force mode					
AF		Auto / manual force mode					
SD		Chip shutdown setting					

TABLE 2-2 - COMMAND CODE 00H REGISTER SETTING					
BITS SETTING		DESCRIPTION	BITS SETTING		DESCRIPTION
BIT 7		Default = 0	BIT 3		Default = 0
BIT 6, 5, 4 IT (2 : 0)		(0 : 0 : 0) = 40 ms	BIT 2 TRIG		0 = no trigger
		(0 : 0 : 1) = 80 ms			1 = trigger one time detect cycle
		(0 : 1 : 0) = 160 ms	BIT 1 AF		0 = auto mode
		(0 : 1 : 1) = 320 ms			1 = force mode
		(1 : 0 : 0) = 640 ms	BIT 0 SD		0 = enable color sensor
		(1 : 0 : 1) = 1280 ms			1 = disable color sensor

TABLE 3-1 - RESERVE COMMAND CODE DESCRIPTION		
RESERVED		COMMAND CODE: 00H / DATA BYTE HIGH
Command	Bit	Description
Reserved	7 : 0	Default = 00H

TABLE 3-2 - RESERVE COMMAND CODE DESCRIPTION		
RESERVED		COMMAND CODE: 01H TO 07H
Command	Bit	Description
Reserved	7 : 0	Default = 00H

TABLE 4 - READ OUT COMMAND CODE DESCRIPTION			
COMMAND CODE	REGISTER	BIT	DESCRIPTION
08H_L (08H data byte low)	R_DATA_L	7 : 0	00H to FFH, R channel LSB output data
08H_H (08H data byte high)	R_DATA_M	7 : 0	00H to FFH, R channel MSB output data
09H_L (09H data byte low)	G_DATA_L	7 : 0	00H to FFH, G channel LSB output data
09H_H (09H data byte high)	G_DATA_M	7 : 0	00H to FFH, G channel MSB output data
0AH_L (0AH data byte low)	B_DATA_L	7 : 0	00H to FFH, B channel LSB output data
0AH_H (0AH data byte high)	B_DATA_M	7 : 0	00H to FFH, B channel MSB output data
0BH_L (0BH data byte low)	W_DATA_L	7 : 0	00H to FFH, W channel LSB output data
0BH_H (0BH data byte high)	W_DATA_M	7 : 0	00H to FFH, W channel MSB output data

PACKAGE INFORMATION in millimeters

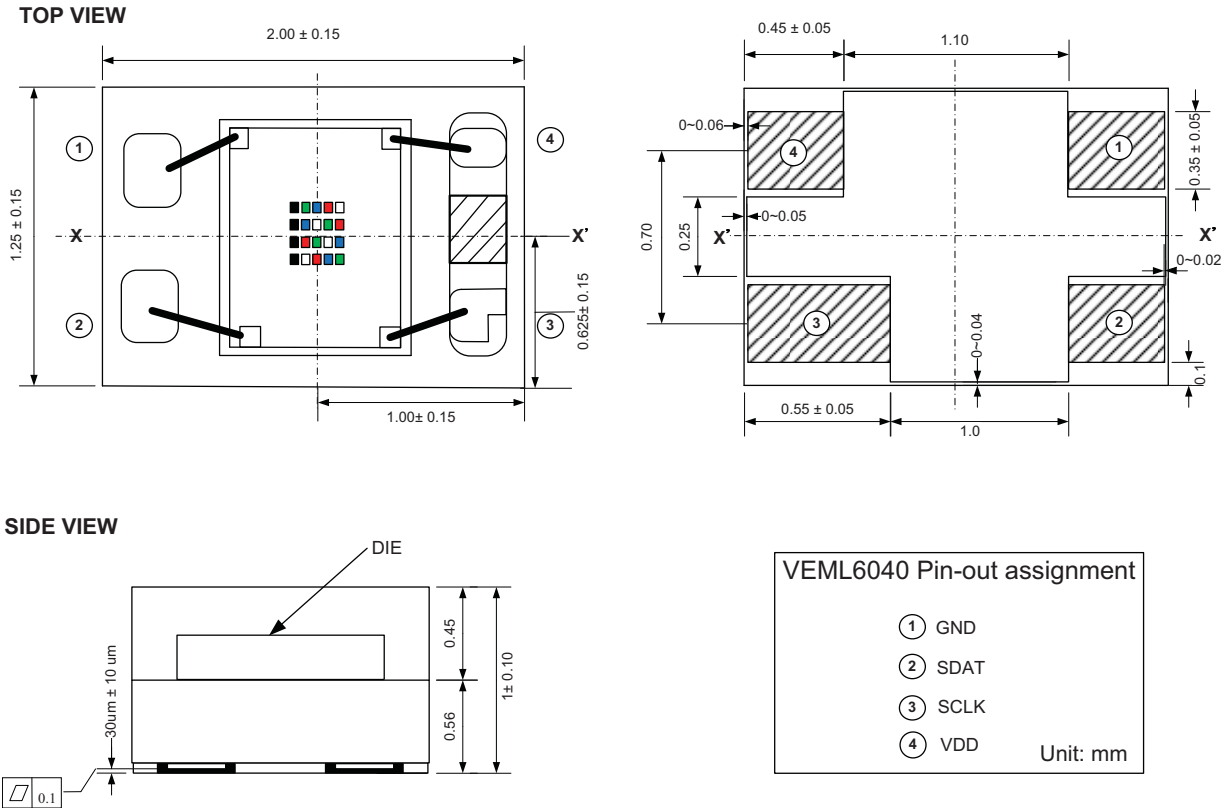


Fig. 8 - VEML6040 A3OG Package Dimensions

LAYOUT NOTICE AND REFERENCE CIRCUIT in millimeters

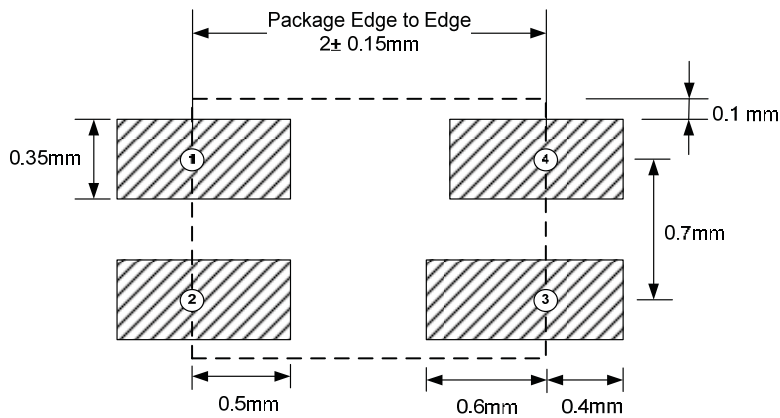


Fig. 9 - VEML6040 PCB Layout Footprint

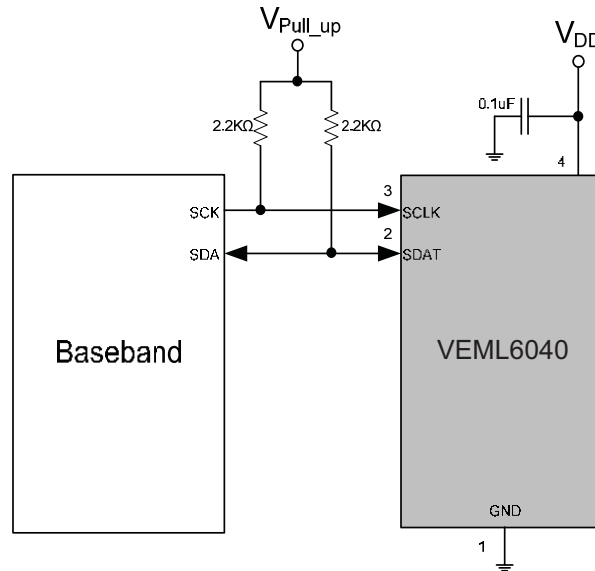
APPLICATION CIRCUIT BLOCK REFERENCE


Fig. 10 - VEML6040 Application Circuit

RECOMMENDED STORAGE AND REBAKING CONDITIONS				
PARAMETER	CONDITIONS	MIN.	MAX.	UNIT
Storage temperature		5	50	°C
Relative humidity			60	%
Open time			168	h
Total time	From the date code on the aluminized envelope (unopened)		12	months
Rebaking	Tape and reel: 60 °C		22	h
	Tube: 60 °C		22	h

RECOMMENDED INFRARED REFLOW

Soldering conditions which are based on J-STD-020 C

IR REFLOW PROFILE CONDITION			
PARAMETER	CONDITIONS	TEMPERATURE	TIME
Peak temperature		255 °C + 0 °C / - 5 °C (max.: 260 °C)	10 s
Preheat temperature range and timing		150 °C to 200 °C	60 s to 180 s
Timing within 5 °C to peak temperature			10 s to 30 s
Timing maintained above temperature / time		217 °C	60 s to 150 s
Timing from 25 °C to peak temperature			8 min (max.)
Ramp-up rate		3 °C/s (max.)	
Ramp-down rate		6 °C/s (max.)	

Recommend Normal Solder Reflow is 235 °C to 255 °C

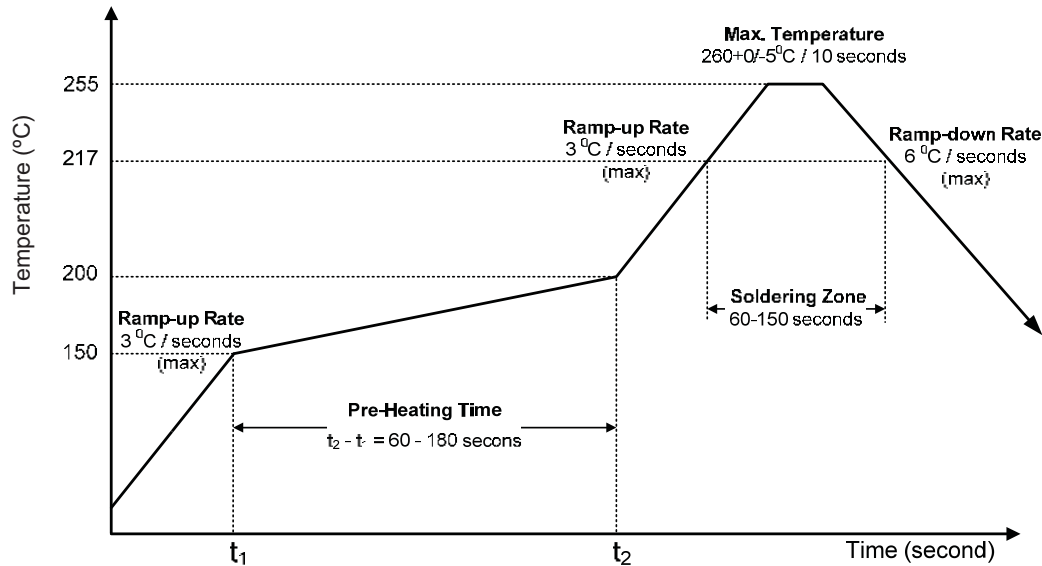


Fig. 11 - VEM6040 OPLGA Solder Reflow Profile Chart

RECOMMENDED IRON TIP SOLDERING CONDITION AND WARNING HANDLING

1. Solder the device with the following conditions:
 - 1.1. Soldering temperature: 400 °C (max.)
 - 1.2. Soldering time: 3 s (max.)
2. If the temperature of the method portion rises in addition to the residual stress between the leads, the possibility that an open or short circuit occurs due to the deformation or destruction of the resin increases.
3. The following methods: VPS and wave soldering, have not been suggested for the component assembly.
4. Cleaning method conditions:
 - 4.1. Solvent: methyl alcohol, ethyl alcohol, isopropyl alcohol
 - 4.2. Solvent temperature < 45 °C (max.)
 - 4.3. Time: 3 min (min.)



TAPE PACKAGING INFORMATION in millimeters

DIMENSION OF CARRIER TAPE

SIDE VIEW

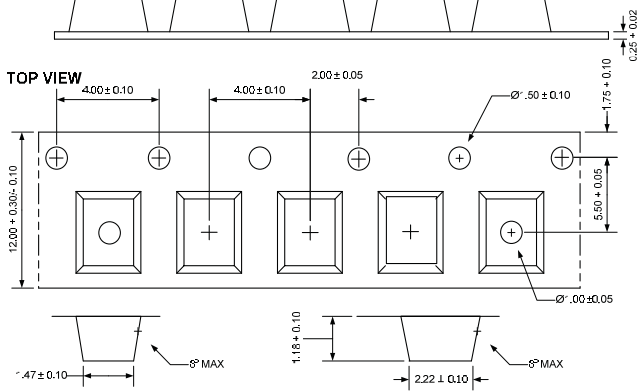


Fig. 12 - VEML6040 A3OG Package Carrier Tape

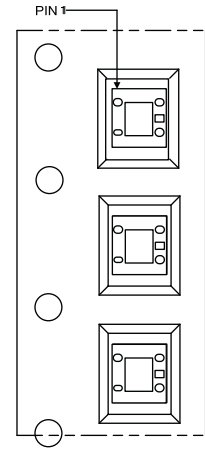


Fig. 13 - Taping Direction

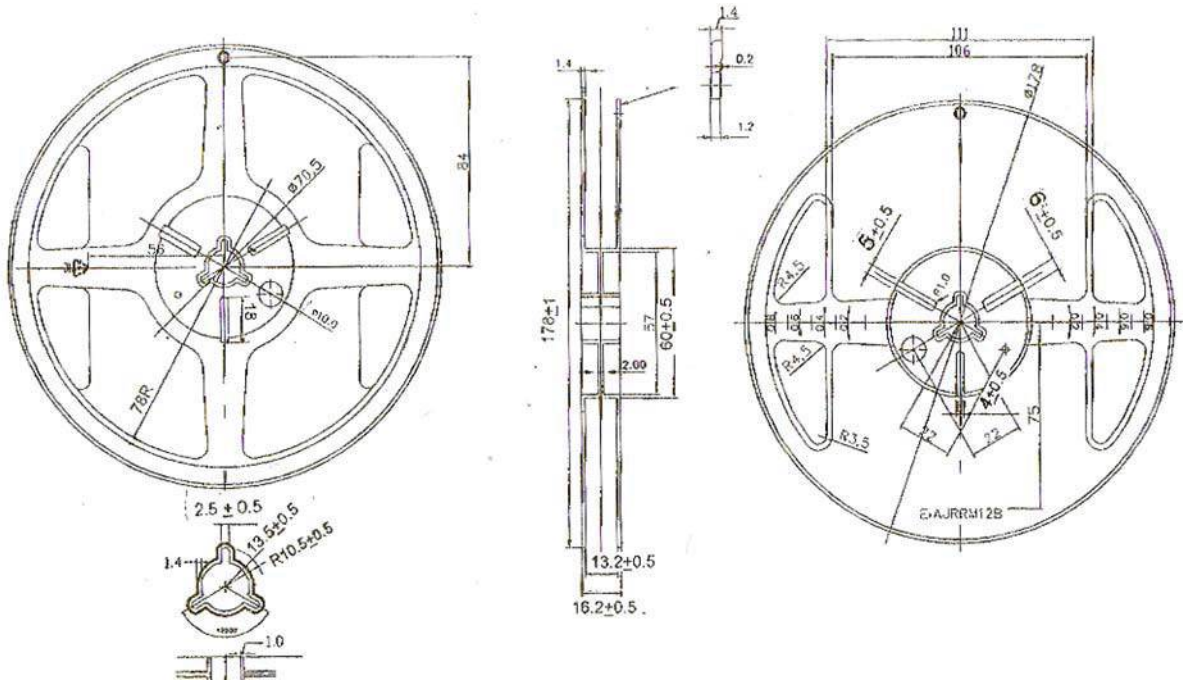


Fig. 14 - Reel Dimensions



Disclaimer

ALL PRODUCT, PRODUCT SPECIFICATIONS AND DATA ARE SUBJECT TO CHANGE WITHOUT NOTICE TO IMPROVE RELIABILITY, FUNCTION OR DESIGN OR OTHERWISE.

Vishay Intertechnology, Inc., its affiliates, agents, and employees, and all persons acting on its or their behalf (collectively, "Vishay"), disclaim any and all liability for any errors, inaccuracies or incompleteness contained in any datasheet or in any other disclosure relating to any product.

Vishay makes no warranty, representation or guarantee regarding the suitability of the products for any particular purpose or the continuing production of any product. To the maximum extent permitted by applicable law, Vishay disclaims (i) any and all liability arising out of the application or use of any product, (ii) any and all liability, including without limitation special, consequential or incidental damages, and (iii) any and all implied warranties, including warranties of fitness for particular purpose, non-infringement and merchantability.

Statements regarding the suitability of products for certain types of applications are based on Vishay's knowledge of typical requirements that are often placed on Vishay products in generic applications. Such statements are not binding statements about the suitability of products for a particular application. It is the customer's responsibility to validate that a particular product with the properties described in the product specification is suitable for use in a particular application. Parameters provided in datasheets and/or specifications may vary in different applications and performance may vary over time. All operating parameters, including typical parameters, must be validated for each customer application by the customer's technical experts. Product specifications do not expand or otherwise modify Vishay's terms and conditions of purchase, including but not limited to the warranty expressed therein.

Except as expressly indicated in writing, Vishay products are not designed for use in medical, life-saving, or life-sustaining applications or for any other application in which the failure of the Vishay product could result in personal injury or death. Customers using or selling Vishay products not expressly indicated for use in such applications do so at their own risk. Please contact authorized Vishay personnel to obtain written terms and conditions regarding products designed for such applications.

No license, express or implied, by estoppel or otherwise, to any intellectual property rights is granted by this document or by any conduct of Vishay. Product names and markings noted herein may be trademarks of their respective owners.

Material Category Policy

Vishay Intertechnology, Inc. hereby certifies that all its products that are identified as RoHS-Compliant fulfill the definitions and restrictions defined under Directive 2011/65/EU of The European Parliament and of the Council of June 8, 2011 on the restriction of the use of certain hazardous substances in electrical and electronic equipment (EEE) - recast, unless otherwise specified as non-compliant.

Please note that some Vishay documentation may still make reference to RoHS Directive 2002/95/EC. We confirm that all the products identified as being compliant to Directive 2002/95/EC conform to Directive 2011/65/EU.

Vishay Intertechnology, Inc. hereby certifies that all its products that are identified as Halogen-Free follow Halogen-Free requirements as per JEDEC JS709A standards. Please note that some Vishay documentation may still make reference to the IEC 61249-2-21 definition. We confirm that all the products identified as being compliant to IEC 61249-2-21 conform to JEDEC JS709A standards.

Компания «Океан Электроники» предлагает заключение долгосрочных отношений при поставках импортных электронных компонентов на взаимовыгодных условиях!

Наши преимущества:

- Поставка оригинальных импортных электронных компонентов напрямую с производств Америки, Европы и Азии, а так же с крупнейших складов мира;
- Широкая линейка поставок активных и пассивных импортных электронных компонентов (более 30 млн. наименований);
- Поставка сложных, дефицитных, либо снятых с производства позиций;
- Оперативные сроки поставки под заказ (от 5 рабочих дней);
- Экспресс доставка в любую точку России;
- Помощь Конструкторского Отдела и консультации квалифицированных инженеров;
- Техническая поддержка проекта, помощь в подборе аналогов, поставка прототипов;
- Поставка электронных компонентов под контролем ВП;
- Система менеджмента качества сертифицирована по Международному стандарту ISO 9001;
- При необходимости вся продукция военного и аэрокосмического назначения проходит испытания и сертификацию в лаборатории (по согласованию с заказчиком);
- Поставка специализированных компонентов военного и аэрокосмического уровня качества (Xilinx, Altera, Analog Devices, Intersil, Interpoint, Microsemi, Actel, Aeroflex, Peregrine, VPT, Syfer, Eurofarad, Texas Instruments, MS Kennedy, Miteq, Cobham, E2V, MA-COM, Hittite, Mini-Circuits, General Dynamics и др.);

Компания «Океан Электроники» является официальным дистрибьютором и эксклюзивным представителем в России одного из крупнейших производителей разъемов военного и аэрокосмического назначения «JONHON», а так же официальным дистрибьютором и эксклюзивным представителем в России производителя высокотехнологичных и надежных решений для передачи СВЧ сигналов «FORSTAR».



JONHON

«JONHON» (основан в 1970 г.)

Разъемы специального, военного и аэрокосмического назначения:

(Применяются в военной, авиационной, аэрокосмической, морской, железнодорожной, горно- и нефтедобывающей отраслях промышленности)

«FORSTAR» (основан в 1998 г.)

ВЧ соединители, коаксиальные кабели, кабельные сборки и микроволновые компоненты:

(Применяются в телекоммуникациях гражданского и специального назначения, в средствах связи, РЛС, а так же военной, авиационной и аэрокосмической отраслях промышленности).



Телефон: 8 (812) 309-75-97 (многоканальный)

Факс: 8 (812) 320-03-32

Электронная почта: ocean@oceanchips.ru

Web: <http://oceanchips.ru/>

Адрес: 198099, г. Санкт-Петербург, ул. Калинина, д. 2, корп. 4, лит. А