



Rev.3.0

AS7C316098B-10TIN AS7C316098B-10BIN

1024K X 16 BIT HIGH SPEED CMOS SRAM

REVISION HISTORY

<u>Revision</u>	<u>Description</u>	<u>Issue Date</u>
Rev. 1.0	Initial Issued	June 2014
Rev. 2.0	Modified page5 "AC ELECTRICAL CHARACTERISTIC" We can offer special screened part "tested and passed for 8ns@ 25°C yield - shown with custom label on packaging as AS7C316098B-10TIN"	November 2017
Rev. 3.0	Added 48-ball TFBGA package as AS7C316098B-10BIN	July 2018

Alliance Memory Inc. 511 Taylor Way, San Carlos, CA 94070 TEL: (650) 610-6800 FAX: (650) 620-9211
Alliance Memory Inc. reserves the right to change products or specification without notice



Rev.3.0

AS7C316098B-10TIN AS7C316098B-10BIN

1024K X 16 BIT HIGH SPEED CMOS SRAM

FEATURES

- Fast access time : 10ns
- **low power consumption:**
Operating current : 70mA (TYP.)
Standby current : 4mA(TYP.)
- Single 3.3V power supply
- All inputs and outputs TTL compatible
- Fully static operation
- Tri-state output
- Data byte control : LB# (DQ0 ~ DQ7)
UB# (DQ8 ~ DQ15)
- Data retention voltage : 1.5V (MIN.)
- **All parts are ROHS Compliant**
- Package : 54-pin 400 mil TSOP-II
48-ball 6mm x 8mm TFBGA

GENERAL DESCRIPTION

The AS7C316098B is a 16M-bit high speed CMOS static random access memory organized as 1024K words by 16 bits. It is fabricated using very high performance, high reliability CMOS technology. Its standby current is stable within the range of operating temperature.

The AS7C316098B operates from a single power supply of 3.3V and all inputs and outputs are fully TTL compatible

Table 1. Speed Grade Information

Product Family	Vcc Range	Speed	Power Dissipation	
			Standby(I _{SB1} ,TYP.)	Operating(I _{CC} ,TYP.)
AS7C316098B	2.7 ~ 3.6V	10ns	4mA	70mA

Table 2. Ordering Information

Product part No	Org	Temperature	Package
AS7C316098B-10BIN	1024K x 16	Industrial -40°C to 85°C	48-ball TFGBA
AS7C316098B-10TIN	1024K x 16	Industrial -40°C to 85°C	54-pin 400mil TSOP-II

Please note: we can also offer a custom part - 'specially screened' part at 8ns at 25°C defined by specific labeling on package as AS7C316098B-10TIN*



Rev.3.0

AS7C316098B-10TIN AS7C316098B-10BIN

1024K X 16 BIT HIGH SPEED CMOS SRAM

FUNCTIONAL BLOCK DIAGRAM

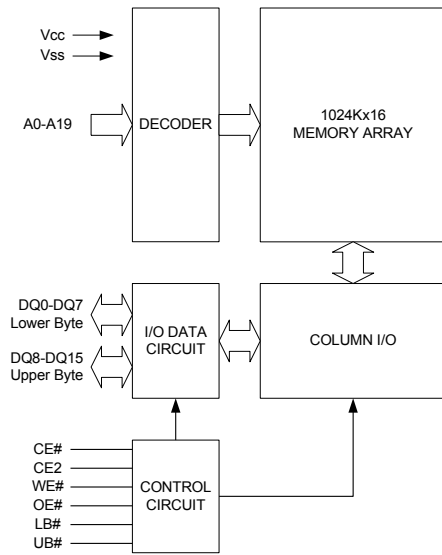

PIN DESCRIPTION

SYMBOL	DESCRIPTION
A0 - A19	Address Inputs
DQ0 - DQ15	Data Inputs/Outputs
CE#, CE2	Chip Enable Input
WE#	Write Enable Input
OE#	Output Enable Input
LB#	Lower Byte Control
UB#	Upper Byte Control
Vcc	Power Supply
Vss	Ground



Rev.3.0

AS7C316098B-10TIN AS7C316098B-10BIN

1024K X 16 BIT HIGH SPEED CMOS SRAM

PIN CONFIGURATION

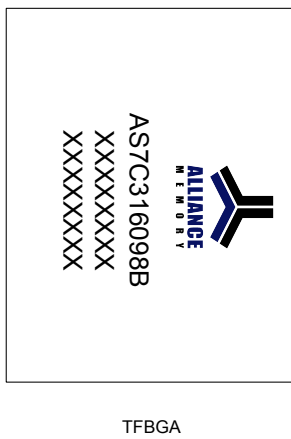
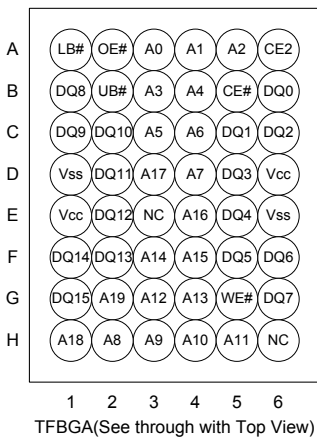
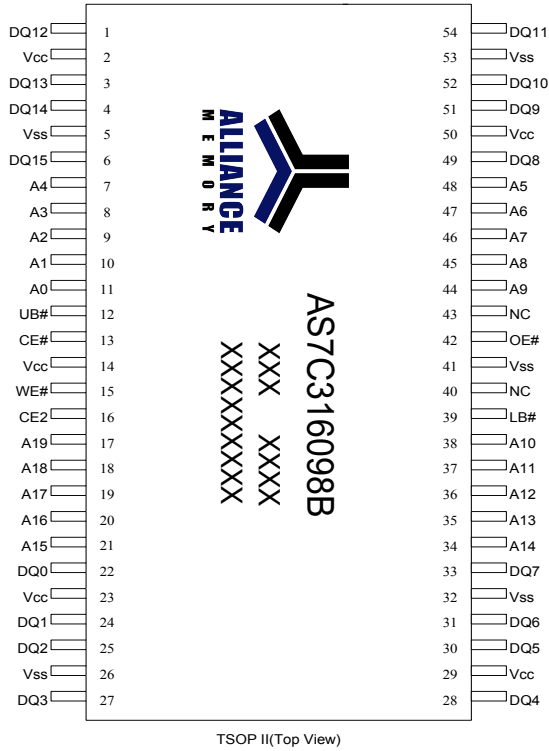



Rev.3.0

AS7C316098B-10TIN AS7C316098B-10BIN

1024K X 16 BIT HIGH SPEED CMOS SRAM

ABSOLUTE MAXIMUM RATINGS*

PARAMETER	SYMBOL	RATING	UNIT
Voltage on Vcc relative to Vss	V_{T1}	-0.5 to 4.6	V
Voltage on any other pin relative to Vss	V_{T2}	-0.5 to Vcc+0.5	V
Operating Temperature	T_A	-40 to 85(I grade)	°C
Storage Temperature	T_{STG}	-65 to 150	°C
Power Dissipation	P_D	1	W
DC Output Current	I_{OUT}	50	mA

*Stresses greater than those listed under "Absolute Maximum Ratings" may cause permanent damage to the device. This is a stress rating only and functional operation of the device or any other conditions above those indicated in the operational sections of this specification is not implied. Exposure to the absolute maximum rating conditions for extended period may affect device reliability.

TRUTH TABLE

MODE	CE#	CE2	OE#	WE#	LB#	UB#	I/O OPERATION		SUPPLY CURRENT
							DQ0-DQ7	DQ8-DQ15	
Standby	H	X	X	X	X	X	High - Z	High - Z	I_{SB1}
	X	L	X	X	X	X	High - Z	High - Z	
Output Disable	L	H	H	H	L	X	High - Z	High - Z	I_{CC}
	L	H	H	H	X	L	High - Z	High - Z	
Read	L	H	L	H	L	H	D_{OUT}	High - Z	I_{CC}
	L	H	L	H	H	L	High - Z	D_{OUT}	
	L	H	L	H	L	L	D_{OUT}	D_{OUT}	
Write	L	H	X	L	L	H	D_{IN}	High - Z	I_{CC}
	L	H	X	L	H	L	High - Z	D_{IN}	
	L	H	X	L	L	L	D_{IN}	D_{IN}	

Note: H = V_{IH} , L = V_{IL} , X = Don't care.

DC ELECTRICAL CHARACTERISTICS (Vcc=2.7V 3.6V)

PARAMETER	SYM.	TEST CONDITION	MIN.	TYP. ⁴	MAX.	UNIT	
Supply Voltage	V_{CC}		2.7	3.3	3.6	V	
Input High Voltage	$V_{IH}^{1,2}$		2.2	-	$V_{CC}+0.3$	V	
Input Low Voltage	$V_{IL}^{1,2}$		-0.3	-	0.8	V	
Input Leakage Current	I_{LI}	$V_{CC} \geq V_{IN} \geq V_{SS}$	-1	-	1	μA	
Output Leakage Current	I_{LO}	$V_{CC} \geq V_{OUT} \geq V_{SS}$, Output Disabled	-1	-	1	μA	
Output High Voltage	V_{OH}	$I_{OH} = -4mA$	2.4	-	-	V	
Output Low Voltage	V_{OL}	$I_{OL} = 8mA$	-	-	0.4	V	
Average Operating Power supply Current	I_{CC}	CE# $\leq 0.2V$ and CE2 $\geq V_{CC}-0.2V$, other pins at 0.2V or $V_{CC}-0.2V$, $I_{IO} = 0mA$; f=max.	-10	-	70	120	mA
Standby Power Supply Current	I_{SB1}	CE# $\geq V_{CC} - 0.2V$; other pins at 0.2V or $V_{CC}-0.2V$.	-	4	40	mA	

Notes:

- $V_{IH(MAX)} = V_{CC} + 2.0V$ for pulse width less than 6ns.
- $V_{IL(MIN)} = V_{SS} - 2.0V$ for pulse width less than 6ns.
- Over/Undershoot specifications are characterized on engineering evaluation stage, not for mass production test.
- Typical values are included for reference only and are not guaranteed or tested.
Typical values are measured at $V_{CC} = V_{CC(TYP)}$ and $T_A = 25^\circ C$



Rev.3.0

AS7C316098B-10TIN AS7C316098B-10BIN

1024K X 16 BIT HIGH SPEED CMOS SRAM

CAPACITANCE ($T_A = 25^\circ\text{C}$, $f = 1.0\text{MHz}$)

PARAMETER	SYMBOL	MIN.	MAX	UNIT
Input Capacitance	C_{IN}	-	8	pF
Input/Output Capacitance	$C_{I/O}$	-	10	pF

Note : These parameters are guaranteed by device characterization, but not production tested.

AC TEST CONDITIONS

speed	10ns
Input Pulse Levels	0.2V to $V_{CC}-0.2V$
Input Rise and Fall Times	3ns
Input and Output Timing Reference Levels	$V_{CC}/2$
Output Load	$C_L = 30\text{pF} + 1\text{TTL}$, $I_{OH}/I_{OL} = -8\text{mA}/4\text{mA}$

AC ELECTRICAL CHARACTERISTICS ($V_{CC}=2.7V$ 3.6V)

(1) READ CYCLE

PARAMETER	SYM.	AS7C316098B-10		Special Screened to-8		UNIT
		MIN.	MAX.	MIN.	MAX.	
Read Cycle Time	t_{RC}	10	-	8	-	ns
Address Access Time	t_{AA}	-	10	-	8	ns
Chip Enable Access Time	t_{ACE}	-	10	-	8	ns
Output Enable Access Time	t_{OE}	-	4.5	-	4.5	ns
Chip Enable to Output in Low-Z	t_{CLZ}^*	2	-	2	-	ns
Output Enable to Output in Low-Z	t_{OLZ}^*	0	-	0	-	ns
Chip Disable to Output in High-Z	t_{CHZ}^*	-	4	-	3	ns
Output Disable to Output in High-Z	t_{OHZ}^*	-	4	-	3	ns
Output Hold from Address Change	t_{OH}	2	-	2	-	ns
LB#, UB# Access Time	t_{BA}	-	4.5	-	4.5	ns
LB#, UB# to High-Z Output	t_{BHZ}^*	-	4	-	3	ns
LB#, UB# to Low-Z Output	t_{BLZ}^*	0	-	0	-	ns

(2) WRITE CYCLE

PARAMETER	SYM.	AS7C316098B-10		Special Screened to -8		UNIT
		MIN.	MAX.	MIN.	MAX.	
Write Cycle Time	t_{WC}	10	-	8	-	ns
Address Valid to End of Write	t_{AW}	8	-	6.5	-	ns
Chip Enable to End of Write	t_{CW}	8	-	6.5	-	ns
Address Set-up Time	t_{AS}	0	-	0	-	ns
Write Pulse Width	t_{WP}	8	-	6.5	-	ns
Write Recovery Time	t_{WR}	0	-	0	-	ns
Data to Write Time Overlap	t_{DW}	6	-	5	-	ns
Data Hold from End of Write Time	t_{DH}	0	-	0	-	ns
Output Active from End of Write	t_{OW}^*	2	-	2	-	ns
Write to Output in High-Z	t_{WHZ}^*	-	4	-	3	ns
LB#, UB# Valid to End of Write	t_{BW}	8	-	6.5	-	ns

*These parameters are guaranteed by device characterization, but not production tested.



Rev.3.0

AS7C316098B-10TIN AS7C316098B-10BIN

1024K X 16 BIT HIGH SPEED CMOS SRAM

TIMING WAVEFORMS

READ CYCLE 1 (Address Controlled) (1,2)

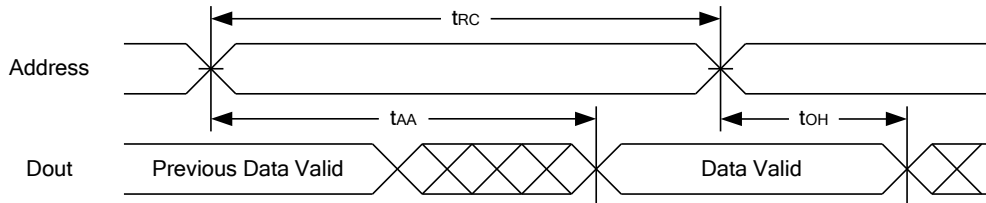

READ CYCLE 2 (CE# and CE2 and OE# Controlled) (1,3,4,5)

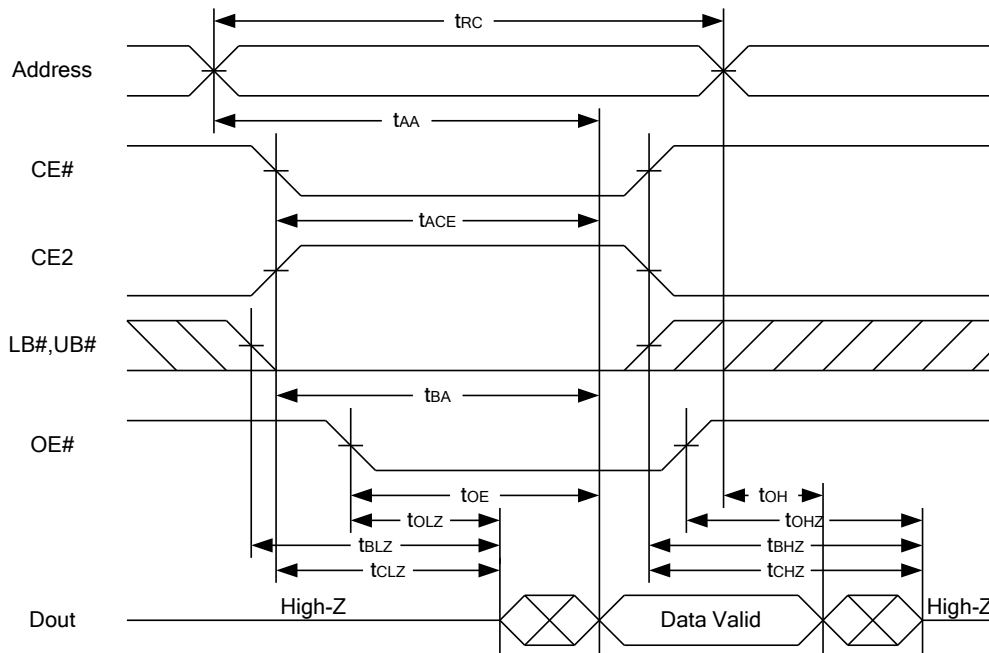

Notes :

1. WE# is high for read cycle.
2. Device is continuously selected OE# = low, CE# = low, CE2 = high, LB# or UB# = low.
3. Address must be valid prior to or coincident with CE# = low, CE2 = high, LB# or UB# = low transition; otherwise t_{AA} is the limiting parameter.
4. t_{CLZ} , t_{BLZ} , t_{OLZ} , t_{CHZ} , t_{BHZ} and t_{OHZ} are specified with $C_L = 5pF$. Transition is measured $\pm 500mV$ from steady state.
5. At any given temperature and voltage condition, t_{CHZ} is less than t_{CLZ} , t_{BHZ} is less than t_{BLZ} , t_{OHZ} is less than t_{OLZ} .



Rev.3.0

AS7C316098B-10TIN AS7C316098B-10BIN

1024K X 16 BIT HIGH SPEED CMOS SRAM

WRITE CYCLE 1 (WE# Controlled) (1,2,3,5,6)

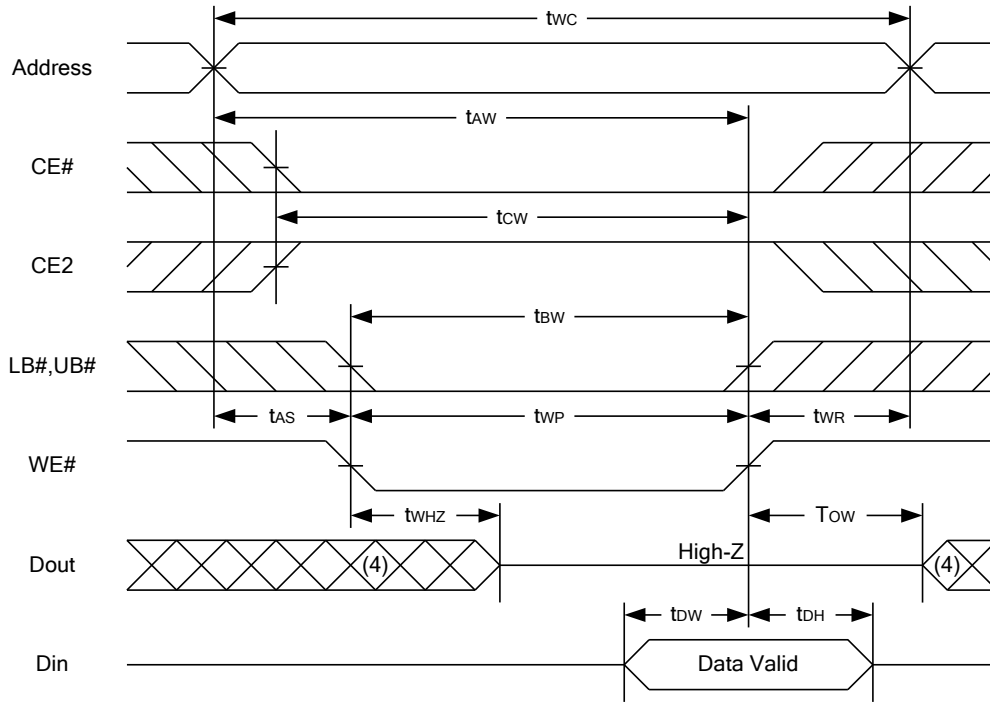

WRITE CYCLE 2 (CE# and CE2 Controlled) (1,2,5,6)

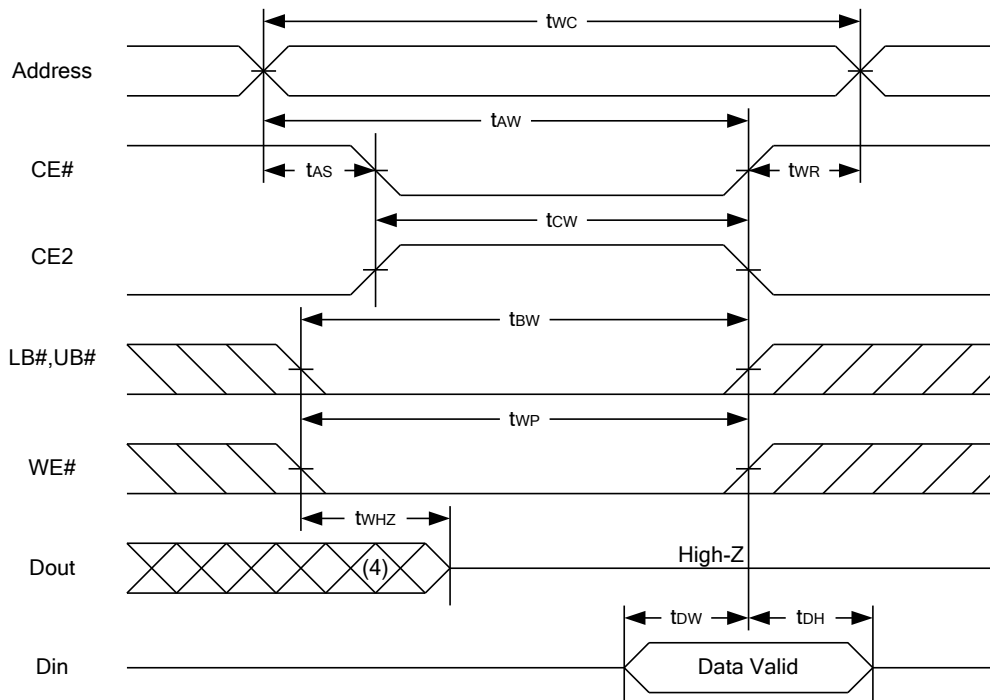



Rev.3.0

AS7C316098B-10TIN AS7C316098B-10BIN

1024K X 16 BIT HIGH SPEED CMOS SRAM

WRITE CYCLE 3 (LB#,UB# Controlled) (1,2,5,6)

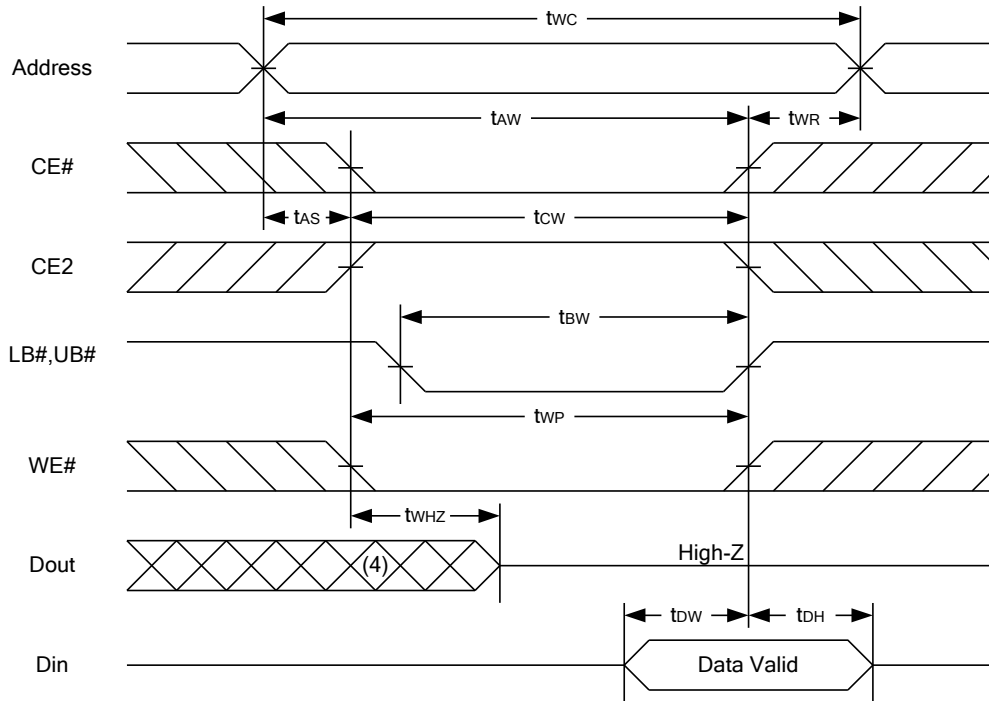

Notes :

1. WE#, CE#, LB#, UB# must be high or CE2 must be low during all address transitions.
2. A write occurs during the overlap of a low CE#, high CE2, low WE#, LB# or UB# = low.
3. During a WE# controlled write cycle with OE# low, t_{WP} must be greater than $t_{WHZ} + t_{OW}$ to allow the drivers to turn off and data to be placed on the bus.
4. During this period, I/O pins are in the output state, and input signals must not be applied.
5. If the CE#, LB#, UB# low transition and CE2 high transition occurs simultaneously with or after WE# low transition, the outputs remain in a high impedance state.
6. t_{OW} and t_{WHZ} are specified with $C_L = 5pF$. Transition is measured $\pm 500mV$ from steady state.



Rev.3.0

AS7C316098B-10TIN AS7C316098B-10BIN

1024K X 16 BIT HIGH SPEED CMOS SRAM

DATA RETENTION CHARACTERISTICS

PARAMETER	SYMBOL	TEST CONDITION	MIN.	TYP.	MAX.	UNIT
V _{CC} for Data Retention	V _{DR}	CE# ≥ V _{CC} - 0.2V or CE2 ≤ 0.2V	1.5	-	3.6	V
Data Retention Current	I _{DR}	V _{CC} = 1.5V CE# ≥ V _{CC} - 0.2V or CE2 ≤ 0.2V Other pins at 0.2V or V _{CC} -0.2V	-	4	40	mA
Chip Disable to Data Retention Time	t _{CDR}	See Data Retention Waveforms (below)	0	-	-	ns
Recovery Time	t _R		t _{RC} *	-	-	ns

t_{RC}* = Read Cycle Time

DATA RETENTION WAVEFORM

Low V_{CC} Data Retention Waveform (1) (CE# controlled)

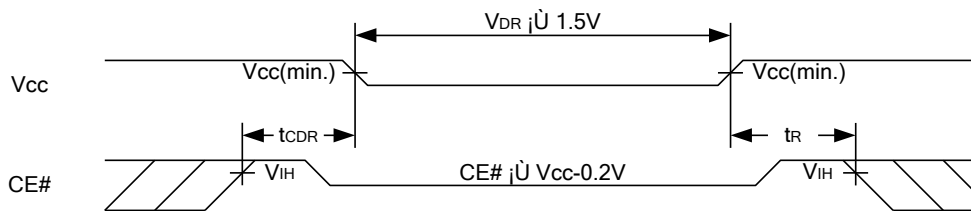

Low V_{CC} Data Retention Waveform (2) (CE2 controlled)

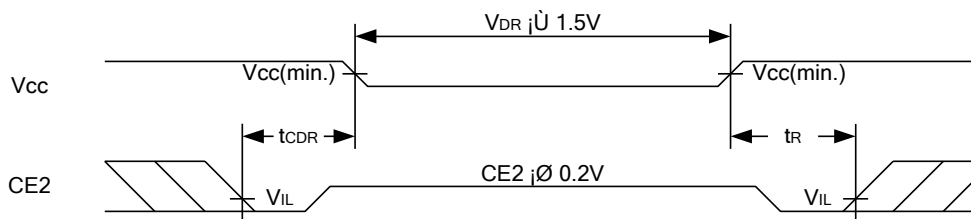

PACKAGE OUTLINE DIMENSION

54-pin 400 mil TSOP-II Package Outline Dimension

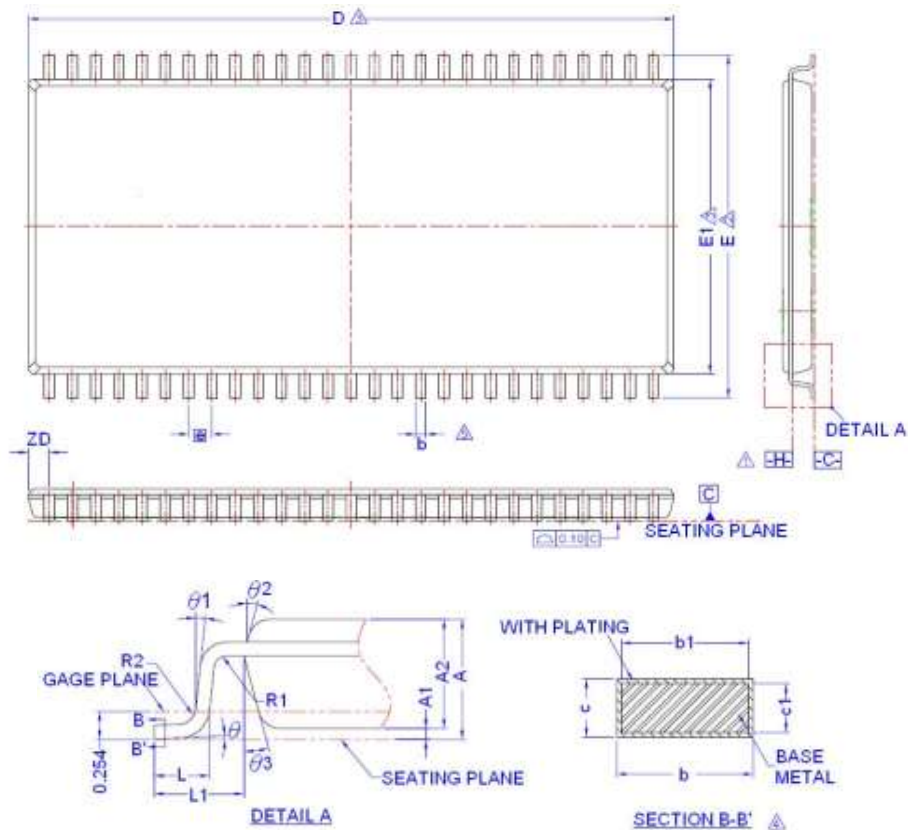

SYM.	DIMENSION (MM)			DIMENSION (INCH)		
	MIN	NOM	MAX	MIN	NOM	MAX
A	-	-	1.20	-	-	0.047
A1	0.05	0.10	0.15	0.002	0.004	0.006
A2	0.95	1.00	1.05	0.037	0.039	0.041
b	0.30	-	0.45	0.012	-	0.018
b1	0.30	0.35	0.40	0.012	0.014	0.016
e	0.12	-	0.21	0.005	-	0.008
c1	0.10	0.127	0.16	0.004	0.005	0.006
D	22.22 BSC			0.875 BSC		
ZD	0.71 REF			0.028 REF		
E	11.76 BSC			0.463 BSC		
E1	10.16 BSC			0.400 BSC		
L	0.40	0.50	0.60	0.016	0.020	0.024
L1	0.80 REF			0.031 REF		
⌀	0.80 BSC			0.031 BSC		
R1	0.12	-	-	0.005	-	-
R2	0.12	-	0.25	0.005	-	0.010
θ	0°	-	8°	0°	-	8°
θ1	0°	-	-	0°	-	-
θ2	10°	15°	20°	10°	15°	20°
θ3	10°	15°	20°	10°	15°	20°

NOTE:

- DATUM PLANE \square COINCIDENT WITH BOTTOM OF LEAD, WHERE LEAD EXITS BODY.
- TO BE DETERMINED AT SEATING PLANE \square .
- DIMENSION D AND E1 ARE DETERMINED AT DATUM \square .
DIMENSION D DOES NOT INCLUDE MOLD PROTRUSIONS OR GATE BURRS. MOLD PROTRUSIONS AND GATE BURRS SHALL NOT EXCEED 0.15mm PER SIDE.
DIMENSION E1 DOES NOT INCLUDE INTERLEAD MOLD PROTRUSIONS. INTERLEAD MOLD PROTRUSIONS SHALL NOT EXCEED 0.25mm PER SIDE.
- THESE DIMENSIONS APPLY TO THE FLAT SECTION OF THE LEAD BETWEEN 0.10mm AND 0.25mm FROM THE LEAD TIP.
- DIMENSION b DOES NOT INCLUDE DAMBAR PROTRUSION/INTRUSION.
- CONTROLLING DIMENSION: MILLIMETER.
- REFER TO JEDEC STD MS-024, FA.

AS7C316098B-10TIN AS7C316098B-10BIN

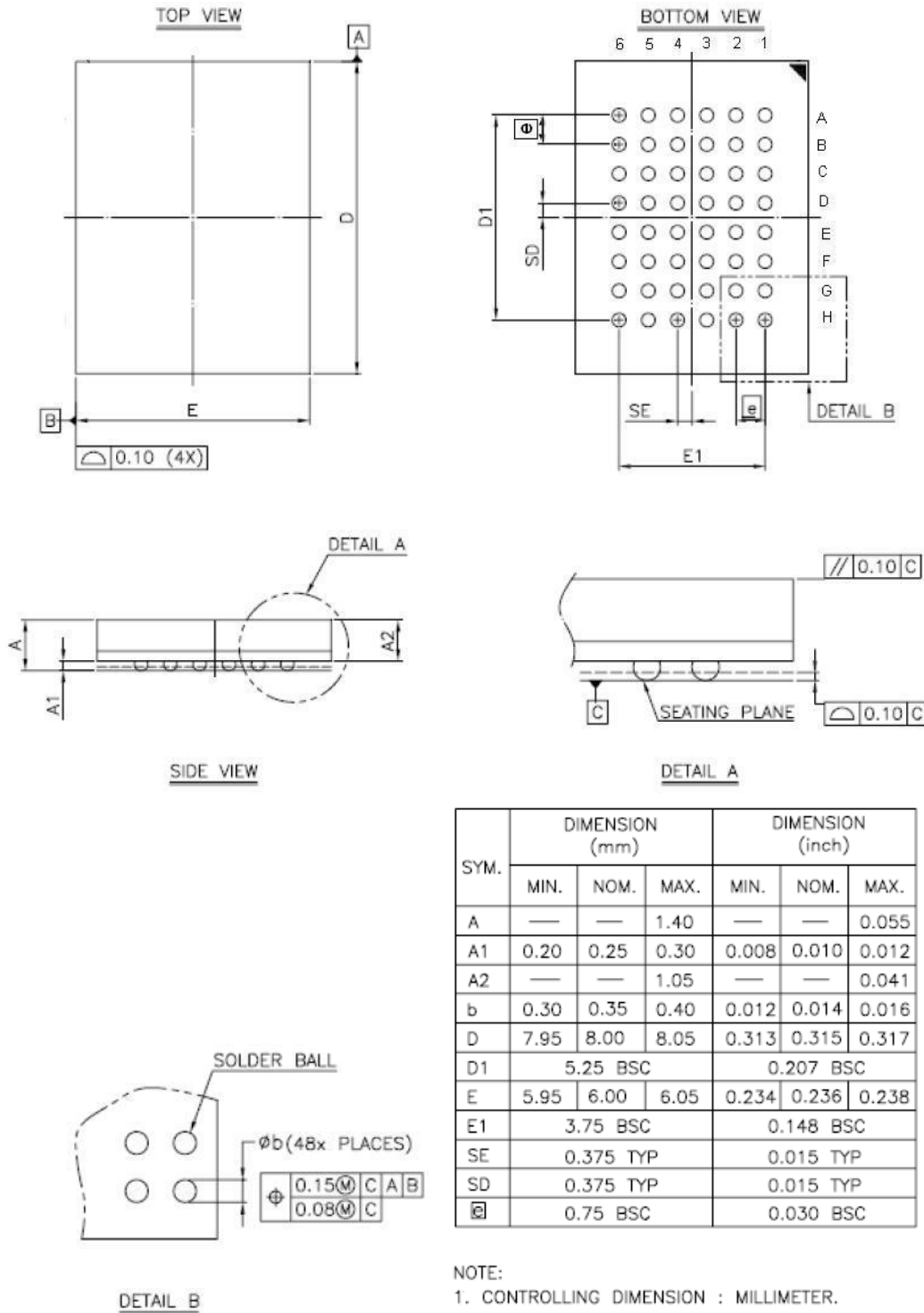
1024K X 16 BIT HIGH SPEED CMOS SRAM
48-ball 6mm × 8mm TFBGA Package Outline Dimension



Rev.3.0

AS7C316098B-10TIN AS7C316098B-10BIN

1024K X 16 BIT HIGH SPEED CMOS SRAM

PART NUMBERING SYSTEM

AS7C	316098B	10	T/B	I	N
SRAM	3=3.3V 16098=1Mx16 B= B die option	10 =10ns	T= 54-pin 400mil TSOP-II	I=Industrial -40°C to 85°C	Indicates Pb and Halogen Free & ROHS Compliant
			B=48-ball TFBGA		

Please note: we can also offer a custom part - 'specially screened' part at 8ns at 25°C defined by specific labeling on package as AS7C316098B-10TIN*

Компания «Океан Электроники» предлагает заключение долгосрочных отношений при поставках импортных электронных компонентов на взаимовыгодных условиях!

Наши преимущества:

- Поставка оригинальных импортных электронных компонентов напрямую с производств Америки, Европы и Азии, а так же с крупнейших складов мира;
- Широкая линейка поставок активных и пассивных импортных электронных компонентов (более 30 млн. наименований);
- Поставка сложных, дефицитных, либо снятых с производства позиций;
- Оперативные сроки поставки под заказ (от 5 рабочих дней);
- Экспресс доставка в любую точку России;
- Помощь Конструкторского Отдела и консультации квалифицированных инженеров;
- Техническая поддержка проекта, помощь в подборе аналогов, поставка прототипов;
- Поставка электронных компонентов под контролем ВП;
- Система менеджмента качества сертифицирована по Международному стандарту ISO 9001;
- При необходимости вся продукция военного и аэрокосмического назначения проходит испытания и сертификацию в лаборатории (по согласованию с заказчиком);
- Поставка специализированных компонентов военного и аэрокосмического уровня качества (Xilinx, Altera, Analog Devices, Intersil, Interpoint, Microsemi, Actel, Aeroflex, Peregrine, VPT, Syfer, Eurofarad, Texas Instruments, MS Kennedy, Miteq, Cobham, E2V, MA-COM, Hittite, Mini-Circuits, General Dynamics и др.);

Компания «Океан Электроники» является официальным дистрибьютором и эксклюзивным представителем в России одного из крупнейших производителей разъемов военного и аэрокосмического назначения «JONHON», а так же официальным дистрибьютором и эксклюзивным представителем в России производителя высокотехнологичных и надежных решений для передачи СВЧ сигналов «FORSTAR».



JONHON

«JONHON» (основан в 1970 г.)

Разъемы специального, военного и аэрокосмического назначения:

(Применяются в военной, авиационной, аэрокосмической, морской, железнодорожной, горно- и нефтедобывающей отраслях промышленности)

«FORSTAR» (основан в 1998 г.)

ВЧ соединители, коаксиальные кабели, кабельные сборки и микроволновые компоненты:

(Применяются в телекоммуникациях гражданского и специального назначения, в средствах связи, РЛС, а так же военной, авиационной и аэрокосмической отраслях промышленности).



Телефон: 8 (812) 309-75-97 (многоканальный)

Факс: 8 (812) 320-03-32

Электронная почта: ocean@oceanchips.ru

Web: <http://oceanchips.ru/>

Адрес: 198099, г. Санкт-Петербург, ул. Калинина, д. 2, корп. 4, лит. А