



MOD-RFID125

User Manual



All boards produced by Olimex are ROHS compliant

Rev.A, February 2008
Copyright(c) 2008, OLIMEX Ltd, All rights reserved

INTRODUCTION:

MOD-RFID125 is an RFID station, able to read Manchester-encoded 64-bit EM4102 tags with 64 periods of carrier frequency per data bit. All the complexity of RFID tag detection, verification and decoding are handled by MOD-RFID125. After it strips the header and the checksums user is given the 40-bit ID of the transponder tag.

MOD-RFID125 supports three distinctive modes of operation, easily switched by a single button press. It can emulate USB HID keyboard and input the read TAG ID directly to any Windows application, including the venerable Notepad. Or it can emulate USB CDC serial port for easy access from custom user applications using standard code for COM port access. The third option allows access from any standard 5V UART, allowing easy integration with existing microcontroller applications.

FEATURES:

- Supports Manchester-encoded 64-bit EM4102 RFID tags with 64 periods of carrier frequency per data bit;
- Base RFID frequency 125kHz;
- USB port connection to PC;
- UART 9600,8N1 connection to user microcontroller boards;
- Three modes of operation, easily changed by pressing the button;
- USB HID keyboard emulation mode;
- USB CDC serial port emulation mode;
- UART connection mode;
- Simple command-line interface in USB CDC and UART modes for configuration and data acquisition;
- Two LEDs indicating device status and tag presence;
- Support for continuous and periodic RF scanning to better suit user power requirements;
- Ships with default mode USB HID and default configuration: continuous read, scan always, one report per second, LEDs activated;

ELECTROSTATIC WARNING:

The MOD-RFID125 board is shipped in protective anti-static packaging. The board must not be subject to high electrostatic potentials. General practice for working with static sensitive devices should be applied when working with this board.

REQUIREMENTS:

Cables: 1.8 meter USB A-B cable.

Software:

Software needed for USB HID keyboard mode:

- Notepad or other text editor.

Software needed for USB CDC and UART modes:

- HyperTerminal or other terminal program.

SUPPORTED RFID TAGS:

MOD-RFID125 supports RFID transponder tags with the following characteristics:

- Based on EM4102 chip;
- 125kHz carrier frequency;
- 64-bit ROM, continuously transmitted;
- 64 periods of carrier frequency per data bit;
- Manchester encoding;

LEDS:

In normal mode the GREEN LED is on whenever the RF antenna circuit is active and scanning for RFID tags. The RED LED switches on whenever a valid RF TAG ID is being scanned and decoded successfully.

The LEDs can be switched off to save power consumption. See the “Command Line Interface” section for more information.

In boot loader mode the LEDs have other meaning. See the “Firmware Upgrade” section for more information.

PC DRIVER INSTALLATION:

Drivers for the USB HID mode are integrated in Windows XP/Vista.

The driver for USB CDC mode is available from our website. Windows installation steps are the following:

- 1.Download and unzip the file “MOD-RFID125-drivers.zip” in a temporary directory.
- 2.Plug the programmer in the USB port.
- 3.Point the Device Wizard to the temporary directory.
- 4.Windows will complain that drivers are not signed. Click “Continue”.
- 5.Click finish.

Screen shots of the steps are shown below:

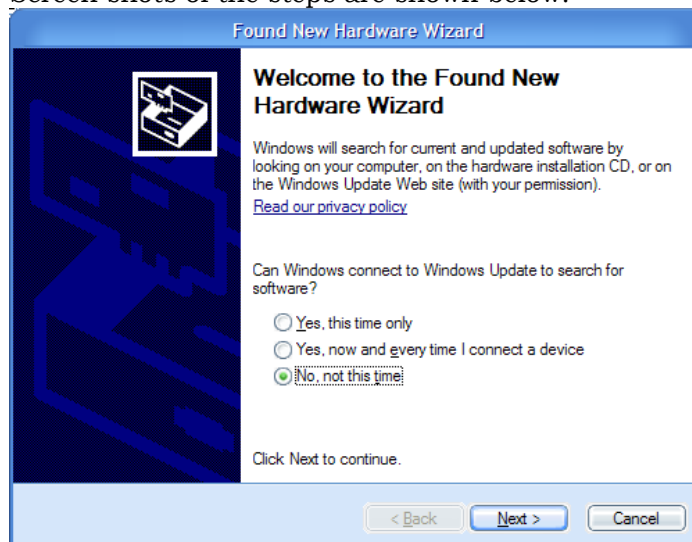

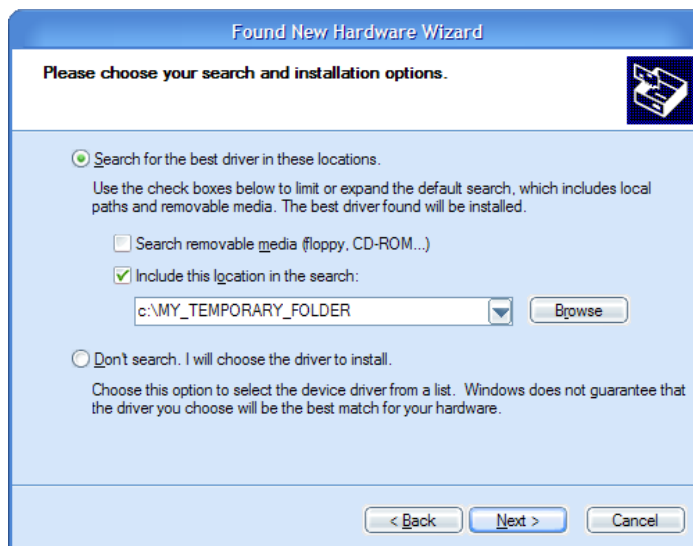
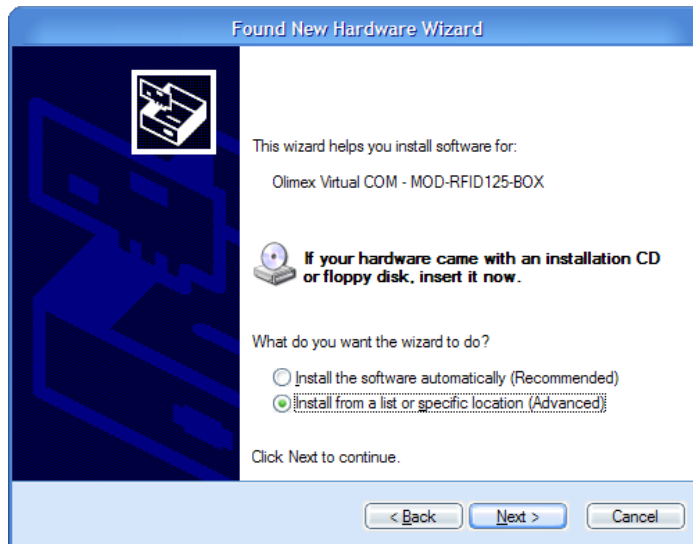

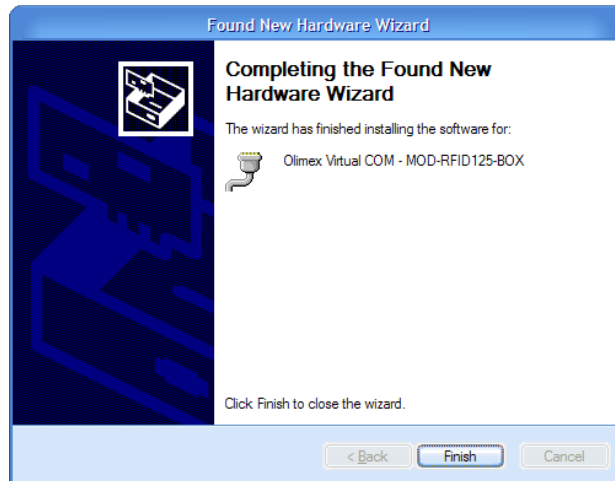

Linux distributions normally include drivers both for USB HID and USB CDC classes. Depending on which driver is loaded in the kernel, user should look either for

`/dev/ttyACMn`

or

`/dev/ttyUSBn`

where "n" is a number, assigned by the kernel to the plugged device.

USB HID MODE:

When device is connected via USB to a host PC it will represent itself as USB HID keyboard. When an RFID transponder is detected in the vicinity, the module will type the HEX-representation of the transponder ID.

To use the device in this mode:

1. Open Notepad.
2. Plug in the device in the USB port of the PC.
3. Put an RFID tag in front of the device. The TAG ID will be entered in the currently opened text file.

There is no need for OS driver because all major operating systems include USB HID drivers.

NOTE: This mode does not allow configuration of device parameters. MOD-RFID125 is shipped with default configuration for continuous read and one second repeat. If this must be changed then device must be switched to USB CDC mode and configured using the serial command line interface.

USB CDC MODE:

In this mode the device represents itself as USB CDC virtual serial port. It provides a simple shell-like command line interface for configuring and interacting with the module. The device echoes back the typed characters and waits for Carriage Return (Enter) before processing the line input. See "Command Line Interface" for more information on the supported commands.

Any terminal software can be used to open the COM port, assigned by the OS, and type in commands.

UART MODE:

In this mode there is no need for USB connection. Instead the device must be connected via TTL-level UART of a microcontroller system of choice. It expects the peer to be configured with 9600 bps, 8bit character, no parity, 1 stop bit. The communication is otherwise the same as in USB CDC mode, but there is no need for USB. Again, all entered characters are echoed back. MOD-RFID125's signals RxD and TxD are leaded away to pads, which are shown at the picture below:

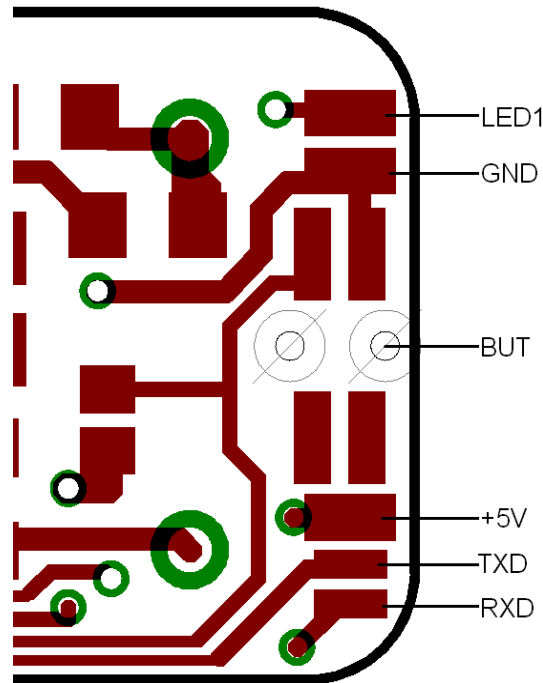

From this side of the board, where is the button, are leaded total five signals: RxD, TxD, LED1, GND and +5V.
TxD – output from MOD-RFID125
RxD – input for MOD-RFID125
LED1 – doubles LED1 command signal.
GND – Ground
+5V - +5V from USB

SWITCHING OPERATING MODES:

The current mode of operation can be selected by pressing and holding the button of the device. After two seconds the LEDs will start to blink and will show the code for the next selected mode. When button is released, the device will reboot and enter the selected mode. Selected mode is remembered between power downs. The assigned codes are:

LED Status		Description	
Red	Green	Previous State	State After Button Is Released
blinks	off	UART	USB HID
off	blinks	USB HID	USB CDC
blinks	blinks	USB CDC	UART

COMMAND LINE INTERFACE (USB CDC and UART modes):

The command line interface, available in USB CDC and UART modes, allows device configuration and reading of successfully decoded TAG IDs. Just open the serial port assigned to MOD-RFID125 using HyperTerminal or similar terminal program, and start typing commands.

For the impatient: type '?' and press enter to see a short help for the supported commands. Any typed character will be echoed back; 'enter' will force the module to process the input command line.

1.Command **?**

This command prints a short help message, describing the available commands and their arguments.

2.Command **i**

This command prints a short information about firmware version, hardware board revision, and currently selected configuration.

3.Command **b**

This command forces the device to enter boot loader mode. After executing this command the device will disconnect itself from USB, switch to boot loader mode, and reconnect itself in anticipation of receiving a firmware upgrade image. See the section "Firmware Upgrade" for more information.

4.Command **r**

This command is only valid if device is in single read mode (see below). It will trigger a single TAG read. If TAG ID is successfully read, it will be printed. Otherwise if operation timed out, zeros will be printed.

5.Command **msXX**

Set single read mode. The XX parameter must be a decimal value, indicating the TAG read timeout in seconds.

Example – setting single read mode with 15 seconds timeout:

ms15

6.Command **mcFR**

Set continuous read mode with frequency F (Hz) and repeat report interval R (seconds). Both F and R must be single digit decimal numbers.

If F is 0 then RF antenna is constantly switched on and the device is scans continuously for tags. Otherwise if F is 1-5, the device will switch the antenna on F times per second.

If R is 0 then a successfully read RF tag ID is reported only once. Otherwise if R is 1-9, the device will report the tag ID every R seconds until the tag is seen in the proximity.

Example – continuous scanning, single report per seen tag:

mc00

Example – scan once per second, single report per seen tag:

mc10

Example – scan twice per second, report a seen tag every second:

mc21

Example – continuous scanning, report a seen tag every 5 seconds:

mc05

7.Command **m1E**

Set LED mode. If E is 0, LEDs will be disabled. Otherwise if E is 1, LEDs will be enabled.

Example – enabling LEDs:

m11

Example – disabling LEDs to conserve power:

m10

Below is a screen shot of command line session using HyperTerminal:

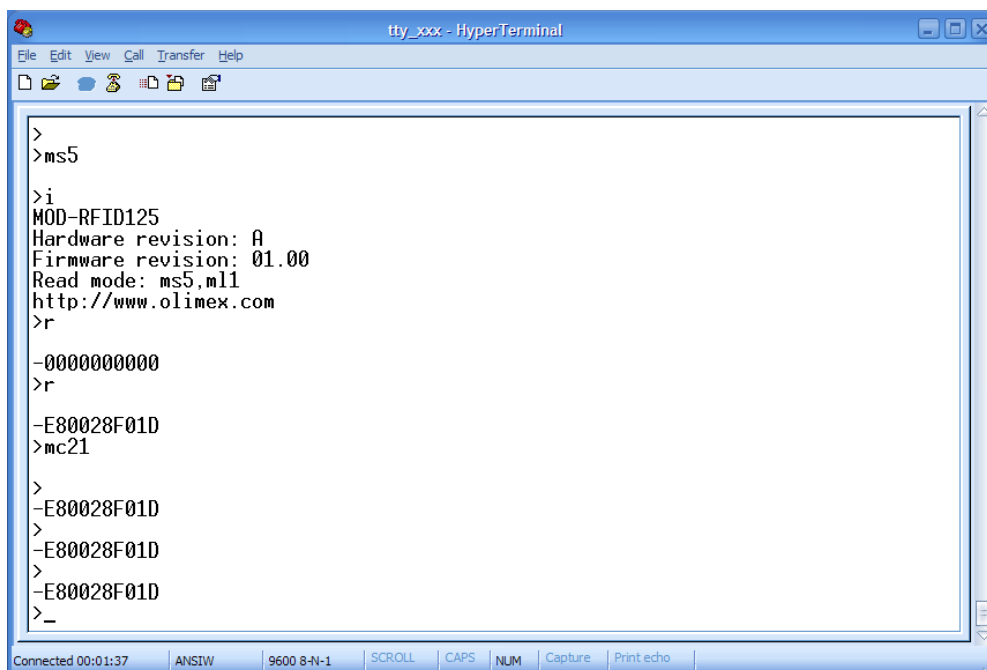

```
>
>ms5
>i
MOD-RFID125
Hardware revision: A
Firmware revision: 01.00
Read mode: ms5,m11
http://www.olimex.com
>r
-0000000000
>r
-E80028F01D
>mc21
>
-E80028F01D
>
-E80028F01D
>
-E80028F01D
>_
```

FIRMWARE UPGRADE:

MOD-RFID125 contains a built-in boot loader for easy firmware upgrade. Device enters boot loader mode if the application FLASH section is corrupted. To force the device to enter boot loader mode for manual firmware update do the following:

- 1.Disconnect the device from any power source (external DC, USB).
- 2.Press and hold the button.
- 3.Power up the device by connecting it to USB.
- 4.Device now must be in boot loader mode, indicated by the LED light sequence:
 - a.RED on, GREEN off.
 - b.RED off, GREEN on.
 - c.RED off, GREEN off.

Button can now be released. The device will stay in boot loader mode until it is power cycled.

Boot loader implements the standard protocol XMODEM with CRC16 for firmware update. User is free to use his favorite terminal client

(HyperTerminal, minicom, etc) to upload the firmware images taken from our website. Boot loader uses an USB virtual serial port that is baudrate agnostic.

As an alternative we provide a simple Windows GUI application for users who don't want to or cannot use terminal software.

After the firmware image is uploaded the target will blink the GREEN LED if update was successful, otherwise it will blink the RED LED if firmware image was invalid or update was unsuccessful. Device stays in this state until it is power cycled.

WARNING: Upgrade via UART is NOT supported! Boot loader supports only USB.

ELECTRICAL CHARACTERISTICS:

Symbol	Description	Condition	Min	Typ	Max	Units
V _{CC}	Power Supply Voltage.		4.5	5	5.5	V
I _{CC,NOLED}	Power Supply Current with deactivated LEDs.	Idle (RF scanning not active)		20		mA
		Continuous scanning		120		mA
		Scanning 2 times per second		36		mA
I _{CC}	Power Supply Current with activated LEDs.	Continuous scanning		130		mA
		Scanning 2 times per second		40		mA

ORDER CODE:

MOD-RFID125 - assembled and tested (no kit, no soldering required)

How to order?

You can order to us directly or by any of our distributors.

Check our web www.olimex.com/dev for more info.

Revision history:

REV.A - create April 2008

Disclaimer:

© 2008 Olimex Ltd. All rights reserved. Olimex®, logo and combinations thereof, are registered trademarks of Olimex Ltd. Other terms and product names may be trademarks of others.

The information in this document is provided in connection with Olimex products. No license, express or implied or otherwise, to any intellectual property right is granted by this document or in connection with the sale of Olimex products.

Neither the whole nor any part of the information contained in or the product described in this document may be adapted or reproduced in any material from except with the prior written permission of the copyright holder.

The product described in this document is subject to continuous development and improvements. All particulars of the product and its use contained in this document are given by OLIMEX in good faith. However all warranties implied or expressed including but not limited to implied warranties of merchantability or fitness for purpose are excluded.

This document is intended only to assist the reader in the use of the product. OLIMEX Ltd. shall not be liable for any loss or damage arising from the use of any information in this document or any error or omission in such information or any incorrect use of the product.

Компания «Океан Электроники» предлагает заключение долгосрочных отношений при поставках импортных электронных компонентов на взаимовыгодных условиях!

Наши преимущества:

- Поставка оригинальных импортных электронных компонентов напрямую с производств Америки, Европы и Азии, а так же с крупнейших складов мира;
- Широкая линейка поставок активных и пассивных импортных электронных компонентов (более 30 млн. наименований);
- Поставка сложных, дефицитных, либо снятых с производства позиций;
- Оперативные сроки поставки под заказ (от 5 рабочих дней);
- Экспресс доставка в любую точку России;
- Помощь Конструкторского Отдела и консультации квалифицированных инженеров;
- Техническая поддержка проекта, помощь в подборе аналогов, поставка прототипов;
- Поставка электронных компонентов под контролем ВП;
- Система менеджмента качества сертифицирована по Международному стандарту ISO 9001;
- При необходимости вся продукция военного и аэрокосмического назначения проходит испытания и сертификацию в лаборатории (по согласованию с заказчиком);
- Поставка специализированных компонентов военного и аэрокосмического уровня качества (Xilinx, Altera, Analog Devices, Intersil, Interpoint, Microsemi, Actel, Aeroflex, Peregrine, VPT, Syfer, Eurofarad, Texas Instruments, MS Kennedy, Miteq, Cobham, E2V, MA-COM, Hittite, Mini-Circuits, General Dynamics и др.);

Компания «Океан Электроники» является официальным дистрибьютором и эксклюзивным представителем в России одного из крупнейших производителей разъемов военного и аэрокосмического назначения «**JONHON**», а так же официальным дистрибьютором и эксклюзивным представителем в России производителя высокотехнологичных и надежных решений для передачи СВЧ сигналов «**FORSTAR**».



JONHON

«**JONHON**» (основан в 1970 г.)

Разъемы специального, военного и аэрокосмического назначения:

(Применяются в военной, авиационной, аэрокосмической, морской, железнодорожной, горно- и нефтедобывающей отраслях промышленности)

«**FORSTAR**» (основан в 1998 г.)

ВЧ соединители, коаксиальные кабели, кабельные сборки и микроволновые компоненты:

(Применяются в телекоммуникациях гражданского и специального назначения, в средствах связи, РЛС, а так же военной, авиационной и аэрокосмической отраслях промышленности).



Телефон: 8 (812) 309-75-97 (многоканальный)

Факс: 8 (812) 320-03-32

Электронная почта: ocean@oceanchips.ru

Web: <http://oceanchips.ru/>

Адрес: 198099, г. Санкт-Петербург, ул. Калинина, д. 2, корп. 4, лит. А