

To our customers,

---

## Old Company Name in Catalogs and Other Documents

---

On April 1<sup>st</sup>, 2010, NEC Electronics Corporation merged with Renesas Technology Corporation, and Renesas Electronics Corporation took over all the business of both companies. Therefore, although the old company name remains in this document, it is a valid Renesas Electronics document. We appreciate your understanding.

Renesas Electronics website: <http://www.renesas.com>

April 1<sup>st</sup>, 2010  
Renesas Electronics Corporation

Issued by: Renesas Electronics Corporation (<http://www.renesas.com>)

Send any inquiries to <http://www.renesas.com/inquiry>.

## Notice

1. All information included in this document is current as of the date this document is issued. Such information, however, is subject to change without any prior notice. Before purchasing or using any Renesas Electronics products listed herein, please confirm the latest product information with a Renesas Electronics sales office. Also, please pay regular and careful attention to additional and different information to be disclosed by Renesas Electronics such as that disclosed through our website.
2. Renesas Electronics does not assume any liability for infringement of patents, copyrights, or other intellectual property rights of third parties by or arising from the use of Renesas Electronics products or technical information described in this document. No license, express, implied or otherwise, is granted hereby under any patents, copyrights or other intellectual property rights of Renesas Electronics or others.
3. You should not alter, modify, copy, or otherwise misappropriate any Renesas Electronics product, whether in whole or in part.
4. Descriptions of circuits, software and other related information in this document are provided only to illustrate the operation of semiconductor products and application examples. You are fully responsible for the incorporation of these circuits, software, and information in the design of your equipment. Renesas Electronics assumes no responsibility for any losses incurred by you or third parties arising from the use of these circuits, software, or information.
5. When exporting the products or technology described in this document, you should comply with the applicable export control laws and regulations and follow the procedures required by such laws and regulations. You should not use Renesas Electronics products or the technology described in this document for any purpose relating to military applications or use by the military, including but not limited to the development of weapons of mass destruction. Renesas Electronics products and technology may not be used for or incorporated into any products or systems whose manufacture, use, or sale is prohibited under any applicable domestic or foreign laws or regulations.
6. Renesas Electronics has used reasonable care in preparing the information included in this document, but Renesas Electronics does not warrant that such information is error free. Renesas Electronics assumes no liability whatsoever for any damages incurred by you resulting from errors in or omissions from the information included herein.
7. Renesas Electronics products are classified according to the following three quality grades: “Standard”, “High Quality”, and “Specific”. The recommended applications for each Renesas Electronics product depends on the product’s quality grade, as indicated below. You must check the quality grade of each Renesas Electronics product before using it in a particular application. You may not use any Renesas Electronics product for any application categorized as “Specific” without the prior written consent of Renesas Electronics. Further, you may not use any Renesas Electronics product for any application for which it is not intended without the prior written consent of Renesas Electronics. Renesas Electronics shall not be in any way liable for any damages or losses incurred by you or third parties arising from the use of any Renesas Electronics product for an application categorized as “Specific” or for which the product is not intended where you have failed to obtain the prior written consent of Renesas Electronics. The quality grade of each Renesas Electronics product is “Standard” unless otherwise expressly specified in a Renesas Electronics data sheets or data books, etc.
  - “Standard”: Computers; office equipment; communications equipment; test and measurement equipment; audio and visual equipment; home electronic appliances; machine tools; personal electronic equipment; and industrial robots.
  - “High Quality”: Transportation equipment (automobiles, trains, ships, etc.); traffic control systems; anti-disaster systems; anti-crime systems; safety equipment; and medical equipment not specifically designed for life support.
  - “Specific”: Aircraft; aerospace equipment; submersible repeaters; nuclear reactor control systems; medical equipment or systems for life support (e.g. artificial life support devices or systems), surgical implantations, or healthcare intervention (e.g. excision, etc.), and any other applications or purposes that pose a direct threat to human life.
8. You should use the Renesas Electronics products described in this document within the range specified by Renesas Electronics, especially with respect to the maximum rating, operating supply voltage range, movement power voltage range, heat radiation characteristics, installation and other product characteristics. Renesas Electronics shall have no liability for malfunctions or damages arising out of the use of Renesas Electronics products beyond such specified ranges.
9. Although Renesas Electronics endeavors to improve the quality and reliability of its products, semiconductor products have specific characteristics such as the occurrence of failure at a certain rate and malfunctions under certain use conditions. Further, Renesas Electronics products are not subject to radiation resistance design. Please be sure to implement safety measures to guard them against the possibility of physical injury, and injury or damage caused by fire in the event of the failure of a Renesas Electronics product, such as safety design for hardware and software including but not limited to redundancy, fire control and malfunction prevention, appropriate treatment for aging degradation or any other appropriate measures. Because the evaluation of microcomputer software alone is very difficult, please evaluate the safety of the final products or system manufactured by you.
10. Please contact a Renesas Electronics sales office for details as to environmental matters such as the environmental compatibility of each Renesas Electronics product. Please use Renesas Electronics products in compliance with all applicable laws and regulations that regulate the inclusion or use of controlled substances, including without limitation, the EU RoHS Directive. Renesas Electronics assumes no liability for damages or losses occurring as a result of your noncompliance with applicable laws and regulations.
11. This document may not be reproduced or duplicated, in any form, in whole or in part, without prior written consent of Renesas Electronics.
12. Please contact a Renesas Electronics sales office if you have any questions regarding the information contained in this document or Renesas Electronics products, or if you have any other inquiries.

(Note 1) “Renesas Electronics” as used in this document means Renesas Electronics Corporation and also includes its majority-owned subsidiaries.

(Note 2) “Renesas Electronics product(s)” means any product developed or manufactured by or for Renesas Electronics.

## 1. Overview

These MCUs are fabricated using a high-performance silicon gate CMOS process, embedding the R8C/Tiny Series CPU core, and is packaged in a 20-pin molded-plastic LSSOP, SDIP or a 28-pin plastic molded-HWQFN. It implements sophisticated instructions for a high level of instruction efficiency. With 1 Mbyte of address space, they are capable of executing instructions at high speed.

Furthermore, the R8C/19 Group has on-chip data flash ROM (1 KB × 2 blocks).

The difference between the R8C/18 Group and R8C/19 Group is only the presence or absence of data flash ROM. Their peripheral functions are the same.

### 1.1 Applications

Electric household appliances, office equipment, housing equipment (sensors, security systems), general industrial equipment, audio equipment, etc.

## 1.2 Performance Overview

Table 1.1 outlines the Functions and Specifications for R8C/18 Group and Table 1.2 outlines the Functions and Specifications for R8C/19 Group.

**Table 1.1 Functions and Specifications for R8C/18 Group**

	Item	Specification
CPU	Number of fundamental instructions	89 instructions
	Minimum instruction execution time	50 ns ( $f(XIN) = 20$ MHz, $VCC = 3.0$ to $5.5$ V) 100 ns ( $f(XIN) = 10$ MHz, $VCC = 2.7$ to $5.5$ V)
	Operation mode	Single-chip
	Address space	1 Mbyte
	Memory capacity	Refer to <b>Table 1.3 Product Information for R8C/18 Group</b>
Peripheral Functions	Ports	I/O ports: 13 pins (including LED drive port) Input port: 3 pins
	LED drive ports	I/O ports: 4 pins
	Timers	Timer X: 8 bits $\times$ 1 channel, timer Z: 8 bits $\times$ 1 channel (Each timer equipped with 8-bit prescaler) Timer C: 16 bits $\times$ 1 channel (Input capture and output compare circuits)
	Serial interfaces	1 channel Clock synchronous serial I/O, UART 1 channel UART
	Comparator	1-bit comparator: 1 circuit, 4 channels
	Watchdog timer	15 bits $\times$ 1 channel (with prescaler) Reset start selectable, count source protection mode
	Interrupts	Internal: 10 sources, External: 4 sources, Software: 4 sources, Priority levels: 7 levels
	Clock generation circuits	2 circuits • Main clock oscillation circuit (with on-chip feedback resistor) • On-chip oscillator (high speed, low speed) High-speed on-chip oscillator has frequency adjustment function
	Oscillation stop detection function	Main clock oscillation stop detection function
	Voltage detection circuit	On-chip
Power-on reset circuit	On-chip	
Electric Characteristics	Supply voltage	$VCC = 3.0$ to $5.5$ V ( $f(XIN) = 20$ MHz) $VCC = 2.7$ to $5.5$ V ( $f(XIN) = 10$ MHz)
	Current consumption	Typ. 9 mA ( $VCC = 5.0$ V, $f(XIN) = 20$ MHz, comparator stopped) Typ. 5 mA ( $VCC = 3.0$ V, $f(XIN) = 10$ MHz, comparator stopped) Typ. 35 $\mu$ A ( $VCC = 3.0$ V, wait mode, peripheral clock off) Typ. 0.7 $\mu$ A ( $VCC = 3.0$ V, stop mode)
Flash Memory	Programming and erasure voltage	$VCC = 2.7$ to $5.5$ V
	Programming and erasure endurance	100 times
Operating Ambient Temperature		-20 to 85°C -40 to 85°C (D version)
Package		20-pin molded-plastic LSSOP
		20-pin molded-plastic SDIP
		28-pin molded-plastic HWQFN

**Table 1.2 Functions and Specifications for R8C/19 Group**

Item		Specification
CPU	Number of fundamental instructions	89 instructions
	Minimum instruction execution time	50 ns ( $f(XIN) = 20$ MHz, $VCC = 3.0$ to $5.5$ V) 100 ns ( $f(XIN) = 10$ MHz, $VCC = 2.7$ to $5.5$ V)
	Operation mode	Single-chip
	Address space	1 Mbyte
	Memory capacity	Refer to <b>Table 1.4 Product Information for R8C/19 Group</b>
Peripheral Functions	Ports	I/O ports: 13 pins (including LED drive port) Input port: 3 pins
	LED drive ports	I/O ports: 4 pins
	Timers	Timer X: 8 bits $\times$ 1 channel, timer Z: 8 bits $\times$ 1 channel (Each timer equipped with 8-bit prescaler) Timer C: 16 bits $\times$ 1 channel (Input capture and output compare circuits)
	Serial interfaces	1 channel Clock synchronous serial I/O, UART 1 channel UART
	Comparator	1-bit comparator: 1 circuit, 4 channels
	Watchdog timer	15 bits $\times$ 1 channel (with prescaler) Reset start selectable, count source protection mode
	Interrupts	Internal: 10 sources, External: 4 sources, Software: 4 sources, Priority levels: 7 levels
	Clock generation circuits	2 circuits • Main clock generation circuit (with on-chip feedback resistor) • On-chip oscillator (high speed, low speed) High-speed on-chip oscillator has frequency adjustment function
	Oscillation stop detection function	Main clock oscillation stop detection function
	Voltage detection circuit	On-chip
	Power-on reset circuit	On-chip
Electric Characteristics	Supply voltage	$VCC = 3.0$ to $5.5$ V ( $f(XIN) = 20$ MHz) $VCC = 2.7$ to $5.5$ V ( $f(XIN) = 10$ MHz)
	Current consumption	Typ. 9 mA ( $VCC = 5.0$ V, $f(XIN) = 20$ MHz, comparator stopped) Typ. 5 mA ( $VCC = 3.0$ V, $f(XIN) = 10$ MHz, comparator stopped) Typ. 35 $\mu$ A ( $VCC = 3.0$ V, wait mode, peripheral clock off) Typ. 0.7 $\mu$ A ( $VCC = 3.0$ V, stop mode)
Flash Memory	Programming and erasure voltage	$VCC = 2.7$ to $5.5$ V
	Programming and erasure endurance	10,000 times (data flash) 1,000 times (program ROM)
Operating Ambient Temperature		-20 to 85°C -40 to 85°C (D version)
Package		20-pin molded-plastic LSSOP 20-pin molded-plastic SDIP 28-pin molded-plastic HWQFN

### 1.3 Block Diagram

Figure 1.1 shows a Block Diagram.

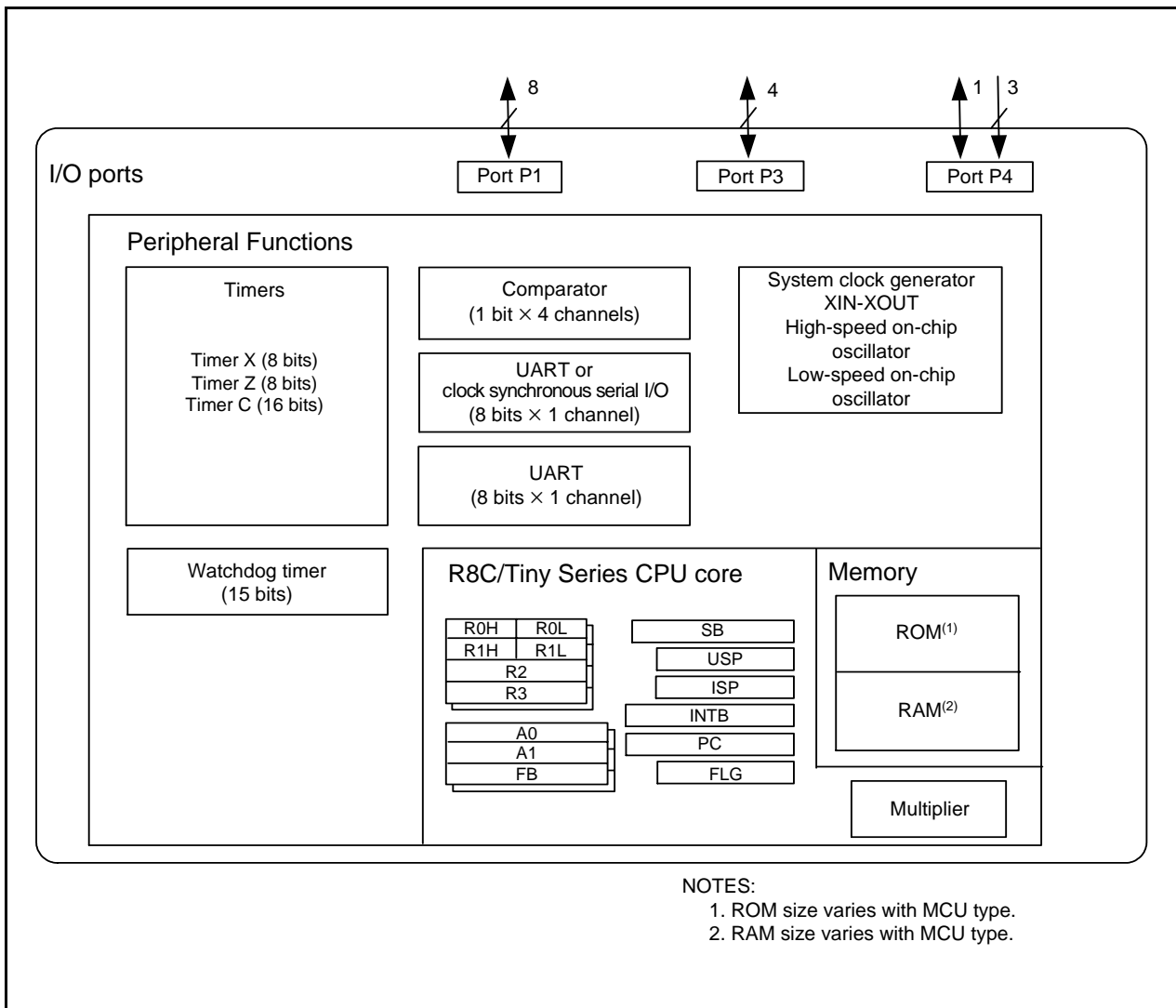

Figure 1.1 Block Diagram

## 1.4 Product Information

Table 1.3 lists Product Information for R8C/18 Group and Table 1.4 lists Product Information for R8C/19 Group.

**Table 1.3 Product Information for R8C/18 Group**

**Current of Apr. 2006**

Type No.	ROM Capacity	RAM Capacity	Package Type	Remarks
R5F21181SP	4 Kbytes	384 bytes	PLSP0020JB-A	Flash memory version  D version
R5F21182SP	8 Kbytes	512 bytes	PLSP0020JB-A	
R5F21183SP	12 Kbytes	768 bytes	PLSP0020JB-A	
R5F21184SP	16 Kbytes	1 Kbyte	PLSP0020JB-A	
R5F21181DSP (D)	4 Kbytes	384 bytes	PLSP0020JB-A	
R5F21182DSP (D)	8 Kbytes	512 bytes	PLSP0020JB-A	
R5F21183DSP (D)	12 Kbytes	768 bytes	PLSP0020JB-A	
R5F21184DSP (D)	16 Kbytes	1 Kbyte	PLSP0020JB-A	
R5F21181DD	4 Kbytes	384 bytes	PRDP0020BA-A	Flash memory version
R5F21182DD	8 Kbytes	512 bytes	PRDP0020BA-A	
R5F21183DD	12 Kbytes	768 bytes	PRDP0020BA-A	
R5F21184DD	16 Kbytes	1 Kbyte	PRDP0020BA-A	
R5F21182NP	8 Kbytes	512 bytes	PWQN0028KA-B	Flash memory version
R5F21183NP	12 Kbytes	768 bytes	PWQN0028KA-B	
R5F21184NP	16 Kbytes	1 Kbyte	PWQN0028KA-B	

(D): Under Development

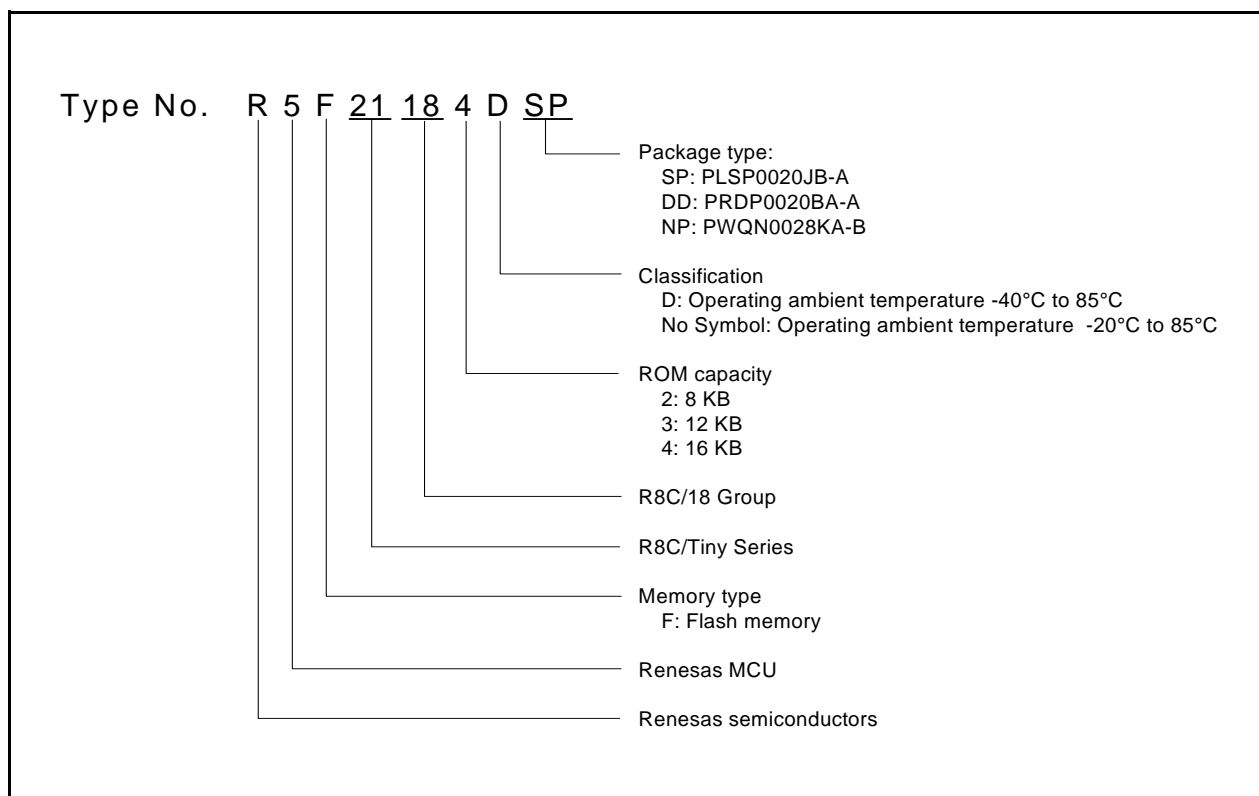

**Figure 1.2 Type Number, Memory Size, and Package of R8C/18 Group**

Table 1.4 Product Information for R8C/19 Group

Current of Apr. 2006

Type No.	ROM Capacity		RAM Capacity	Package Type	Remarks
	Program ROM	Data flash			
R5F21191SP	4 Kbytes	1 Kbyte × 2	384 bytes	PLSP0020JB-A	Flash memory version  D version
R5F21192SP	8 Kbytes	1 Kbyte × 2	512 bytes	PLSP0020JB-A	
R5F21193SP	12 Kbytes	1 Kbyte × 2	768 bytes	PLSP0020JB-A	
R5F21194SP	16 Kbytes	1 Kbyte × 2	1 Kbyte	PLSP0020JB-A	
R5F21191DSP (D)	4 Kbytes	1 Kbyte × 2	384 bytes	PLSP0020JB-A	
R5F21192DSP (D)	8 Kbytes	1 Kbyte × 2	512 bytes	PLSP0020JB-A	
R5F21193DSP (D)	12 Kbytes	1 Kbyte × 2	768 bytes	PLSP0020JB-A	
R5F21194DSP (D)	16 Kbytes	1 Kbyte × 2	1 Kbyte	PLSP0020JB-A	
R5F21191DD	4 Kbytes	1 Kbyte × 2	384 bytes	PRDP0020BA-A	Flash memory version
R5F21192DD	8 Kbytes	1 Kbyte × 2	512 bytes	PRDP0020BA-A	
R5F21193DD	12 Kbytes	1 Kbyte × 2	768 bytes	PRDP0020BA-A	
R5F21194DD	16 Kbytes	1 Kbyte × 2	1 Kbyte	PRDP0020BA-A	
R5F21192NP	8 Kbytes	1 Kbyte × 2	512 bytes	PWQN0028KA-B	Flash memory version
R5F21193NP	12 Kbytes	1 Kbyte × 2	768 bytes	PWQN0028KA-B	
R5F21194NP	16 Kbytes	1 Kbyte × 2	1 Kbyte	PWQN0028KA-B	

(D): Under Development

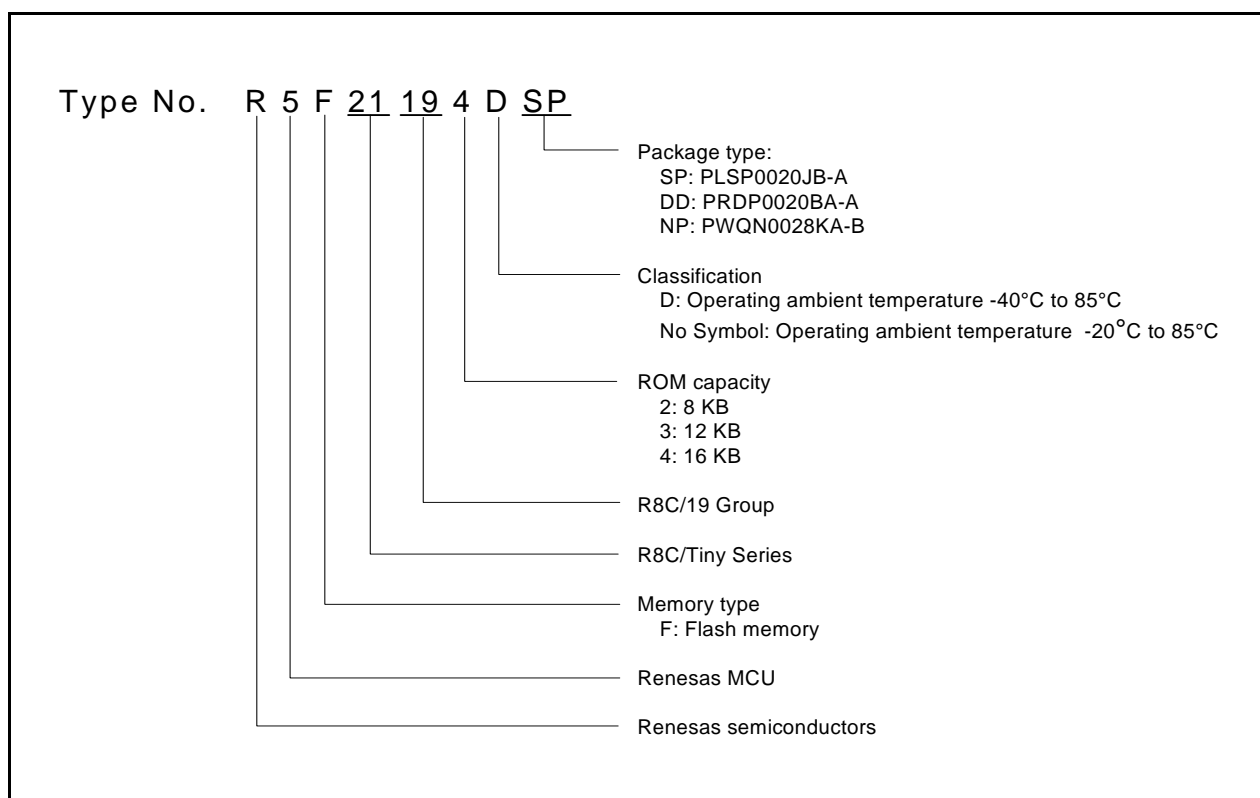

Figure 1.3 Type Number, Memory Size, and Package of R8C/19 Group



## 1.5 Pin Assignments

Figure 1.4 shows Pin Assignments for PLSP0020JB-A Package (Top View), Figure 1.5 shows Pin Assignments for PRDP0020BA-A Package (Top View) and Figure 1.6 shows Pin Assignments for PWQN0028KA-B Package (Top View).

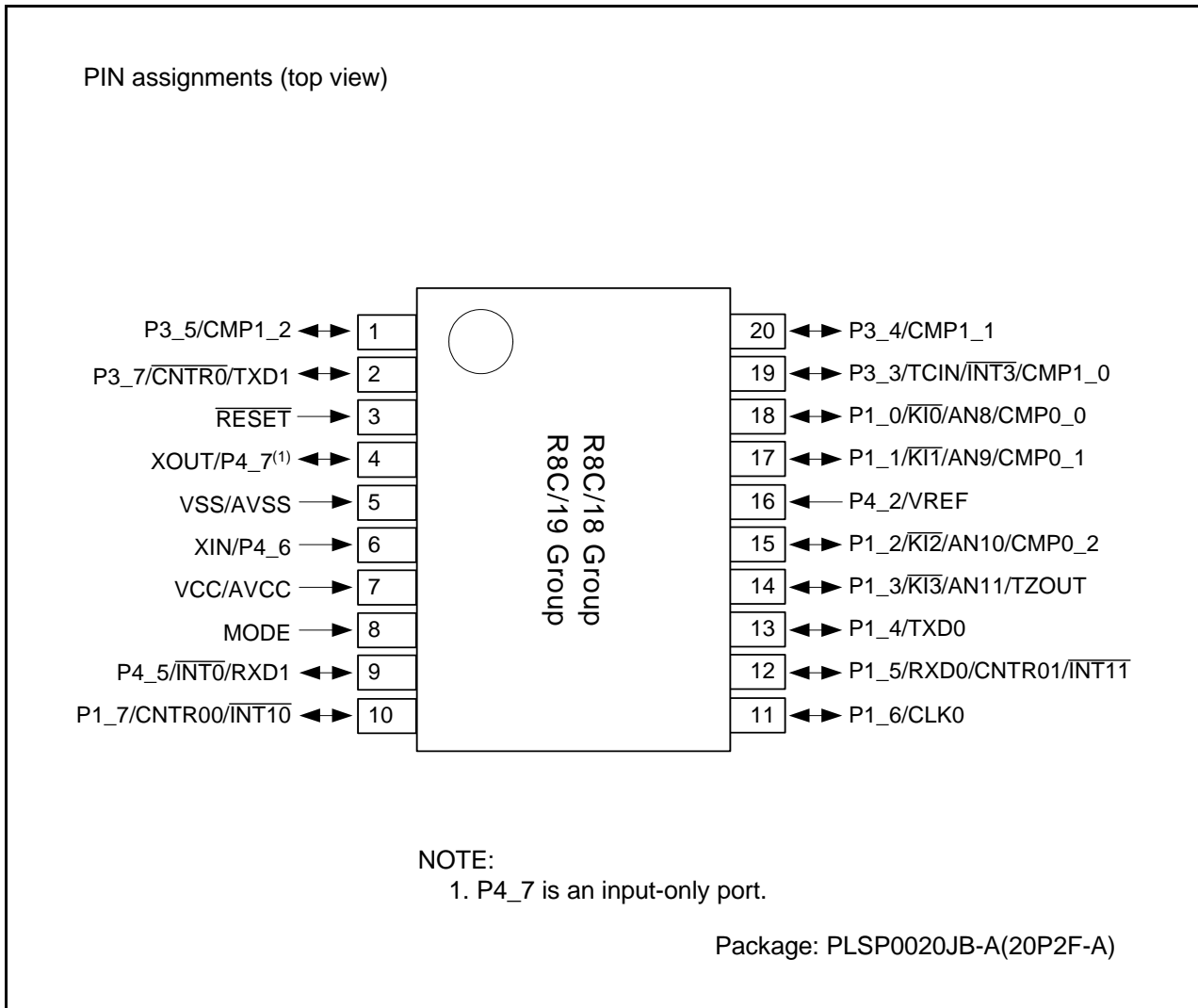

Figure 1.4 Pin Assignments for PLSP0020JB-A Package (Top View)

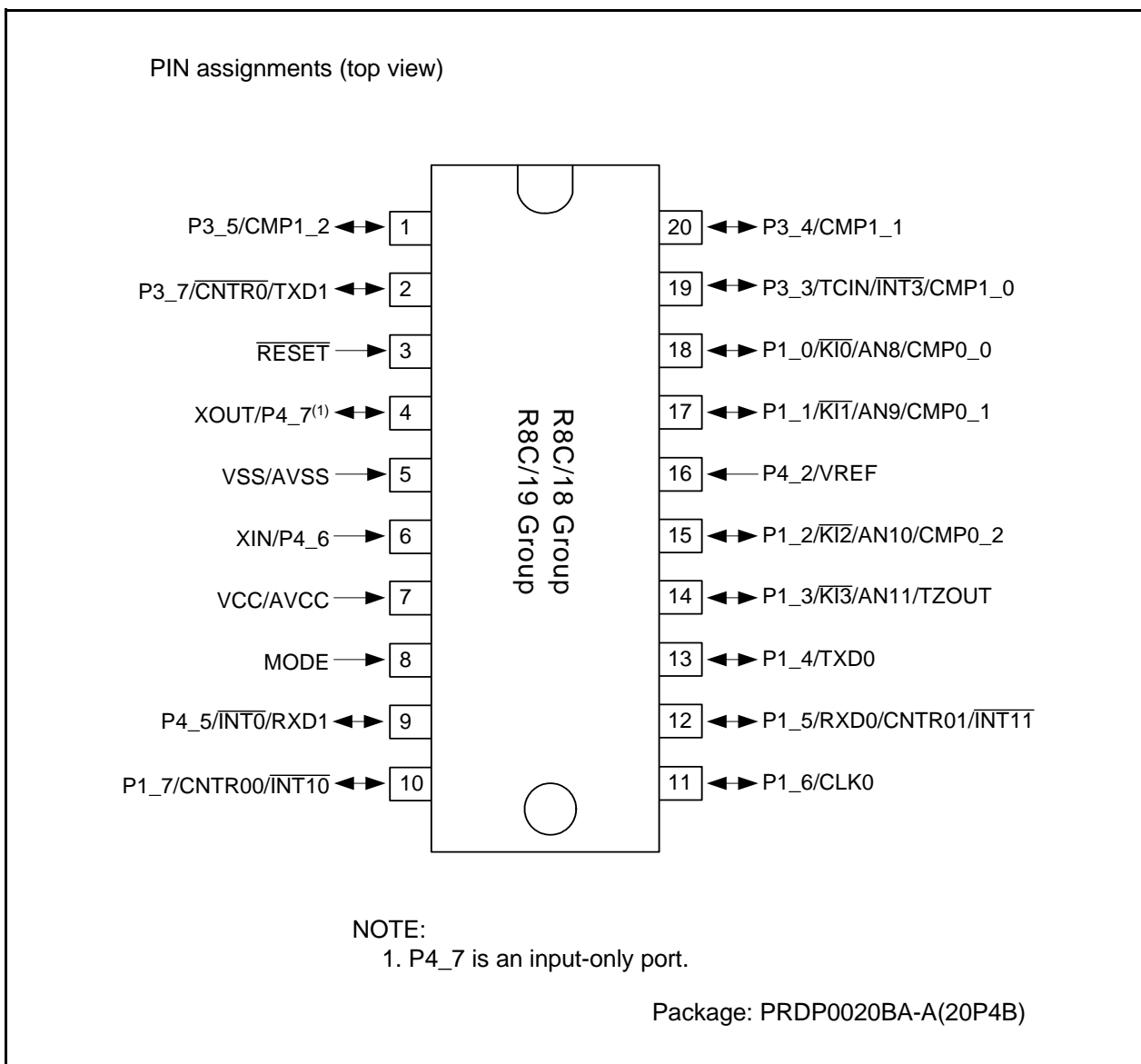

Figure 1.5 Pin Assignments for PRDP0020BA-A Package (Top View)

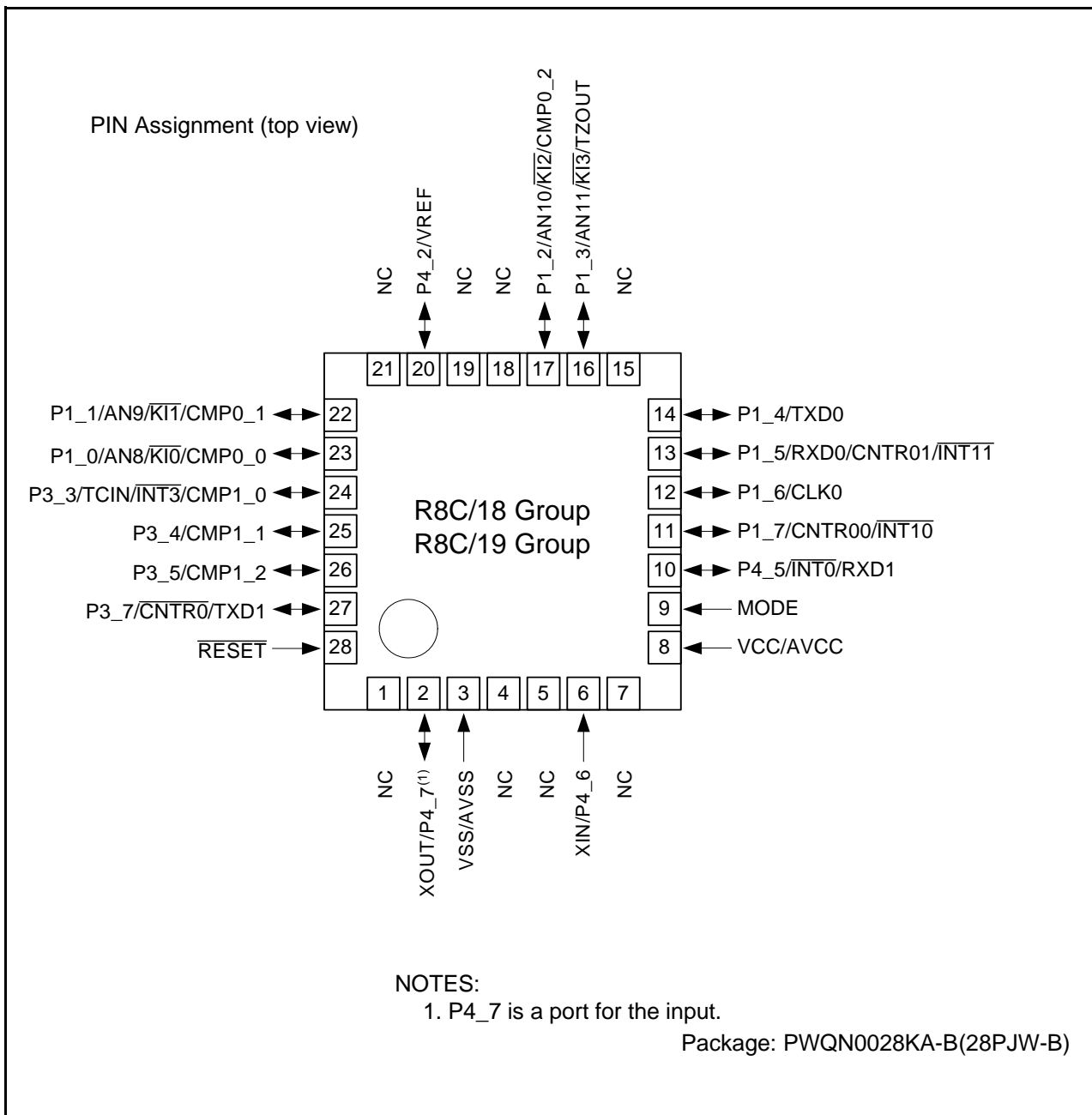

Figure 1.6 Pin Assignments for PWQN0028KA-B Package (Top View)

## 1.6 Pin Functions

Table 1.5 lists Pin Functions, Table 1.6 lists Pin Name Information by Pin Number of PLSP0020JB-A, PRDP0020BA-A packages, and Table 1.7 lists Pin Name Information by Pin Number of PWQN0028KA-B package.

**Table 1.5 Pin Functions**

Type	Symbol	I/O Type	Description
Power supply input	VCC VSS	I	Apply 2.7 V to 5.5 V to the VCC pin. Apply 0 V to the VSS pin.
Analog power supply input	AVCC, AVSS	I	Power supply for the comparator Connect a capacitor between AVCC and AVSS.
Reset input	RESET	I	Input "L" on this pin resets the MCU.
MODE	MODE	I	Connect this pin to VCC via a resistor.
Main clock input	XIN	I	These pins are provided for main clock generation circuit I/O. Connect a ceramic resonator or a crystal oscillator between the XIN and XOUT pins. To use an external clock, input it to the XIN pin and leave the XOUT pin open.
Main clock output	XOUT	O	
INT interrupt	INT0, INT1, INT3	I	INT interrupt input pins
Key input interrupt	KI0 to KI3	I	Key input interrupt input pins
Timer X	CNTR0	I/O	Timer X I/O pin
	CNTR0	O	Timer X output pin
Timer Z	TZOUT	O	Timer Z output pin
Timer C	TCIN	I	Timer C input pin
	CMP0_0 to CMP0_2, CMP1_0 to CMP1_2	O	Timer C output pins
Serial interface	CLK0	I/O	Transfer clock I/O pin
	RXD0, RXD1	I	Serial data input pins
	TXD0, TXD1	O	Serial data output pins
Reference voltage input	VREF	I	Reference voltage input pin to comparator
Comparator	AN8 to AN11	I	Analog input pins to comparator
I/O port	P1_0 to P1_7, P3_3 to P3_5, P3_7, P4_5	I/O	CMOS I/O ports. Each port has an I/O select direction register, allowing each pin in the port to be directed for input or output individually. Any port set to input can be set to use a pull-up resistor or not by a program. P1_0 to P1_3 also function as LED drive ports.
Input port	P4_2, P4_6, P4_7	I	Input-only ports

I: Input    O: Output    I/O: Input and output

**Table 1.6 Pin Name Information by Pin Number of PLSP0020JB-A, PRDP0020BA-A packages**

Pin Number	Control Pin	Port	I/O Pin Functions for Peripheral Modules			
			Interrupt	Timer	Serial Interface	Comparator
1		P3_5		CMP1_2		
2		P3_7		CNTR0	TXD1	
3	RESET					
4	XOUT	P4_7				
5	VSS/AVSS					
6	XIN	P4_6				
7	VCC/AVCC					
8	MODE					
9		P4_5	INT0		RXD1	
10		P1_7	INT10	CNTR00		
11		P1_6			CLK0	
12		P1_5	INT11	CNTR01	RXD0	
13		P1_4			TXD0	
14		P1_3	KI3	TZOUT		AN11
15		P1_2	KI2	CMP0_2		AN10
16	VREF	P4_2				
17		P1_1	KI1	CMP0_1		AN9
18		P1_0	KI0	CMP0_0		AN8
19		P3_3	INT3	TCIN/CMP1_0		
20		P3_4		CMP1_1		

**Table 1.7 Pin Name Information by Pin Number of PWQN0028KA-B package**

Pin Number	Control Pin	Port	I/O Pin of Peripheral Function			
			Interrupt	Timer	Serial Interface	Comparator
1	NC					
2	XOUT	P4_7				
3	VSS/AVSS					
4	NC					
5	NC					
6	XIN	P4_6				
7	NC					
8	VCC/AVCC					
9	MODE					
10		P4_5	$\overline{\text{INT0}}$		RXD1	
11		P1_7	$\overline{\text{INT10}}$	CNTR00		
12		P1_6			CLK0	
13		P1_5	$\overline{\text{INT11}}$	CNTR01	RXD0	
14		P1_4			TXD0	
15	NC					
16		P1_3	$\overline{\text{KI3}}$	TZOUT		AN11
17		P1_2	$\overline{\text{KI2}}$	CMP0_2		AN10
18	NC					
19	NC					
20	VREF	P4_2				
21	NC					
22		P1_1	$\overline{\text{KI1}}$	CMP0_1		AN9
23		P1_0	$\overline{\text{KI0}}$	CMP0_0		AN8
24		P3_3	$\overline{\text{INT3}}$	TCIN/CMP1_0		
25		P3_4		CMP1_1		
26		P3_5		CMP1_2		
27		P3_7		$\overline{\text{CNTR0}}$	TXD1	
28	$\overline{\text{RESET}}$					

## 2. Central Processing Unit (CPU)

Figure 2.1 shows the CPU Registers. The CPU contains 13 registers. R0, R1, R2, R3, A0, A1, and FB configure a register bank. There are two sets of register bank.

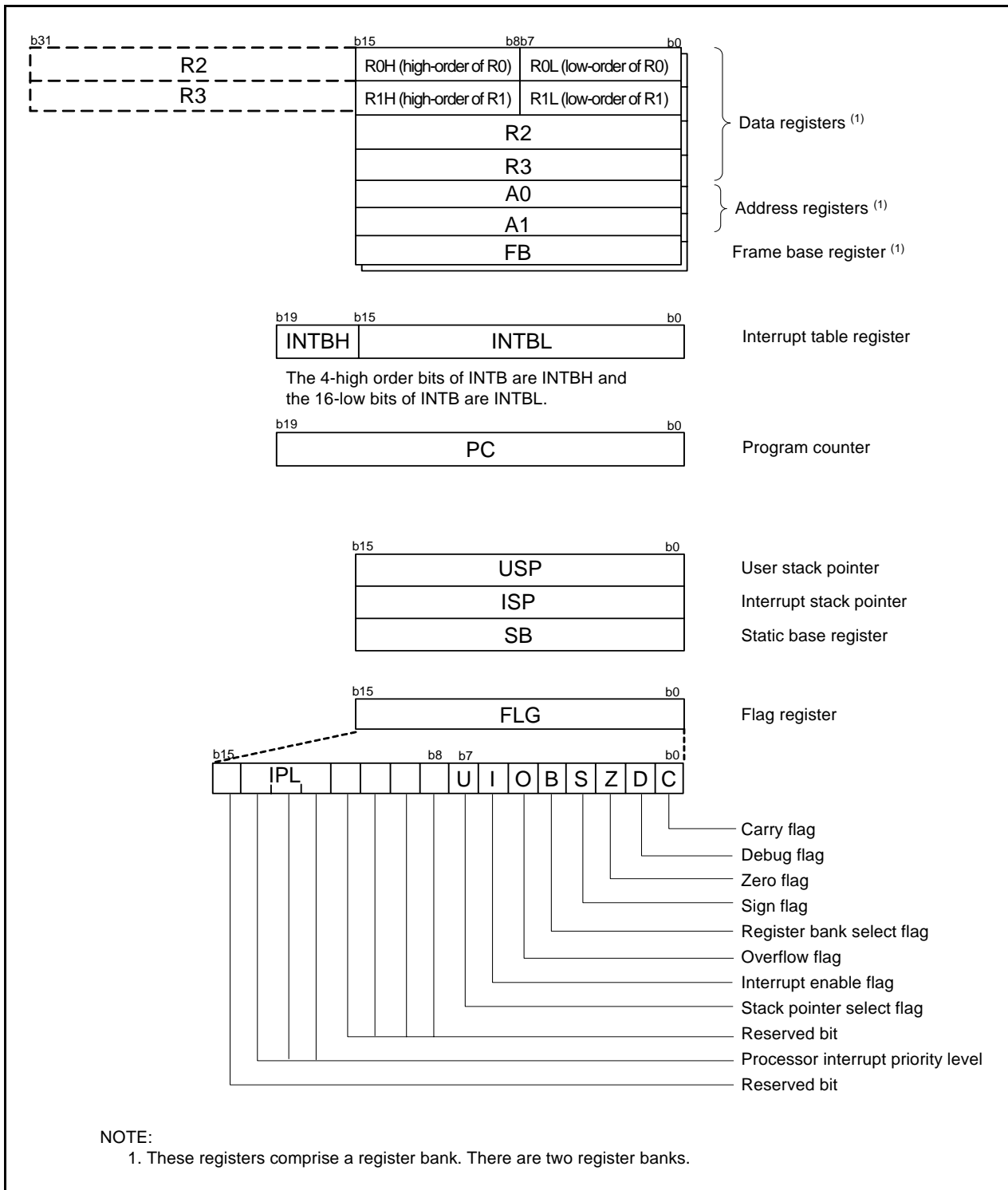

Figure 2.1 CPU Registers

## 2.1 Data Registers (R0, R1, R2, and R3)

R0 is a 16-bit register for transfer, arithmetic, and logic operations. The same applies to R1 to R3. R0 can be split into high-order bits (R0H) and low-order bits (R0L) to be used separately as 8-bit data registers. R1H and R1L are analogous to R0H and R0L. R2 can be combined with R0 and used as a 32-bit data register (R2R0). R3R1 is analogous to R2R0.

## 2.2 Address Registers (A0 and A1)

A0 is a 16-bit register for address register indirect addressing and address register relative addressing. It is also used for transfer, arithmetic and logic operations. A1 is analogous to A0. A1 can be combined with A0 and used as a 32-bit address register (A1A0).

## 2.3 Frame Base Register (FB)

FB is a 16-bit register for FB relative addressing.

## 2.4 Interrupt Table Register (INTB)

INTB is a 20-bit register that indicates the start address of an interrupt vector table.

## 2.5 Program Counter (PC)

PC is 20 bits wide, indicates the address of the next instruction to be executed.

## 2.6 User Stack Pointer (USP) and Interrupt Stack Pointer (ISP)

The stack pointer (SP), USP, and ISP, are each 16 bits wide. The U flag of FLG is used to switch between USP and ISP.

## 2.7 Static Base Register (SB)

SB is a 16-bit register for SB relative addressing.

## 2.8 Flag Register (FLG)

FLG is an 11-bit register indicating the CPU state.

### 2.8.1 Carry Flag (C)

The C flag retains a carry, borrow, or shift-out bits that have been generated by the arithmetic and logic unit.

### 2.8.2 Debug Flag (D)

The D flag is for debugging only. Set it to 0.

### 2.8.3 Zero Flag (Z)

The Z flag is set to 1 when an arithmetic operation results in 0; otherwise to 0.

### 2.8.4 Sign Flag (S)

The S flag is set to 1 when an arithmetic operation results in a negative value; otherwise to 0.

### 2.8.5 Register Bank Select Flag (B)

Register bank 0 is selected when the B flag is 0. Register bank 1 is selected when this flag is set to 1.

### 2.8.6 Overflow Flag (O)

The O flag is set to 1 when the operation results in an overflow; otherwise to 0.



### **2.8.7 Interrupt Enable Flag (I)**

The I flag enables maskable interrupts.

Interrupts are disabled when the I flag is set to 0, and are enabled when the I flag is set to 1. The I flag is set to 0 when an interrupt request is acknowledged.

### **2.8.8 Stack Pointer Select Flag (U)**

ISP is selected when the U flag is set to 0; USP is selected when the U flag is set to 1.

The U flag is set to 0 when a hardware interrupt request is acknowledged or the INT instruction of software interrupt numbers 0 to 31 is executed.

### **2.8.9 Processor Interrupt Priority Level (IPL)**

IPL is 3 bits wide, assigns processor interrupt priority levels from level 0 to level 7.

If a requested interrupt has higher priority than IPL, the interrupt is enabled.

### **2.8.10 Reserved Bit**

If necessary, set to 0. When read, the content is undefined.

### 3. Memory

#### 3.1 R8C/18 Group

Figure 3.1 is a Memory Map of R8C/18 Group. The R8C/18 Group has 1 Mbyte of address space from addresses 00000h to FFFFFh.

The internal ROM area is allocated lower addresses, beginning with address 0C000h. For example, a 16-Kbyte internal ROM is allocated addresses 0C000h to 0FFFFh.

The fixed interrupt vector table is allocated addresses 0FFDCh to 0FFFFh. They store the starting address of each interrupt routine.

The internal RAM is allocated higher addresses, beginning with address 00400h. For example, a 1-Kbyte internal RAM area is allocated addresses 00400h to 007FFh. The internal RAM is used not only for storing data but also for calling subroutines and as stacks when interrupt requests are acknowledged.

Special function registers (SFRs) are allocated addresses 00000h to 002FFh. The peripheral function control registers are allocated here. All addresses within the SFR, which have nothing allocated are reserved for future use and cannot be accessed by users.

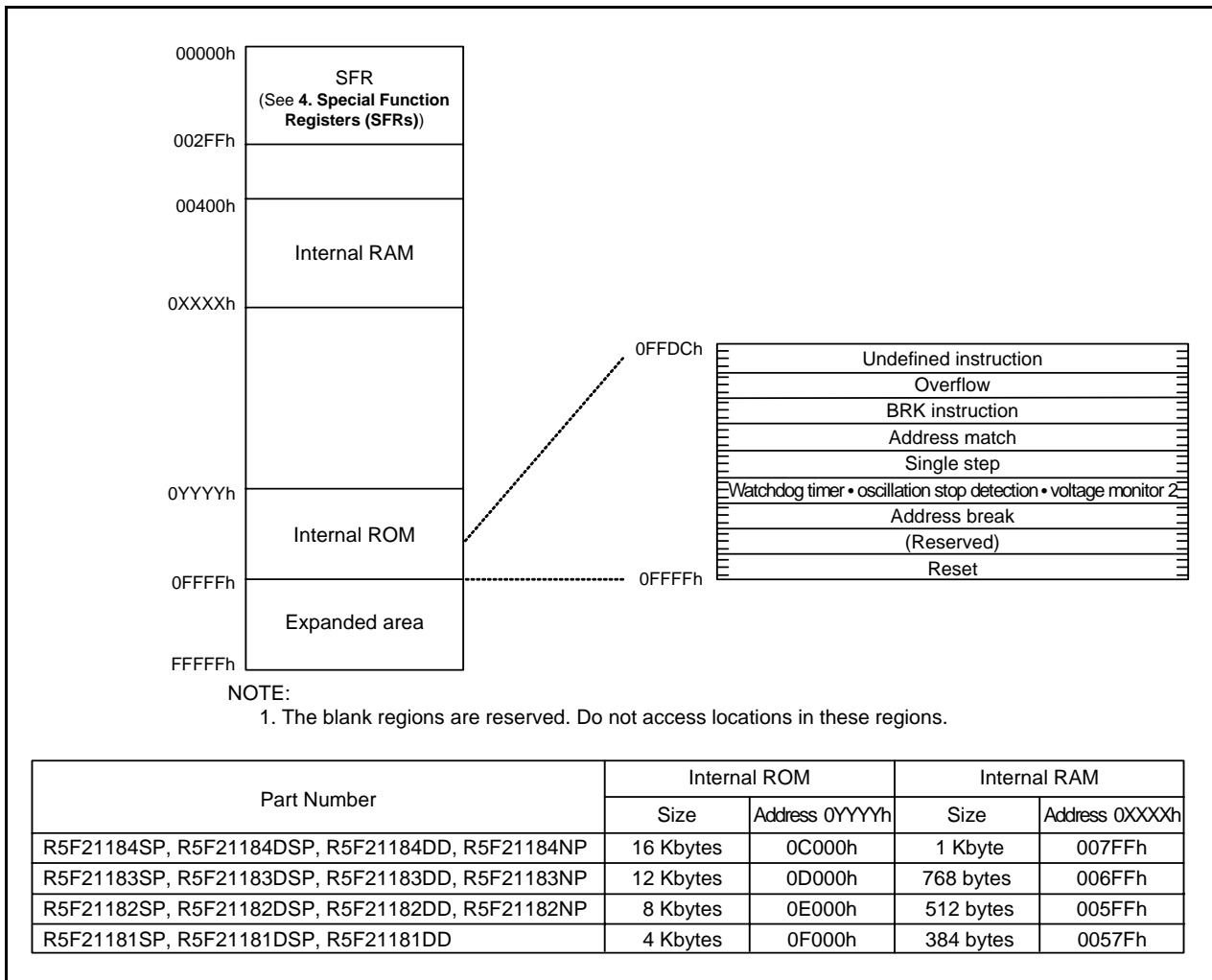

Figure 3.1 Memory Map of R8C/18 Group

### 3.2 R8C/19 Group

Figure 3.2 is a Memory Map of R8C/19 Group. The R8C/19 group has 1 Mbyte of address space from addresses 00000h to FFFFFh.

The internal ROM (program ROM) is allocated lower addresses, beginning with address 00000h. For example, a 16-Kbyte internal ROM area is allocated addresses 0C000h to 0FFFFh.

The fixed interrupt vector table is allocated addresses 0FFDCh to 0FFFFh. They store the starting address of each interrupt routine.

The internal ROM (data flash) is allocated addresses 02400h to 02BFFh.

The internal RAM is allocated higher addresses, beginning with address 00400h. For example, a 1-Kbyte internal RAM area is allocated addresses 00400h to 007FFh. The internal RAM is used not only for storing data but also for calling subroutines and as stacks when interrupt requests are acknowledged.

Special function registers (SFRs) are allocated addresses 00000h to 002FFh. The peripheral function control registers are allocated here. All addresses within the SFR, which have nothing allocated are reserved for future use and cannot be accessed by users.

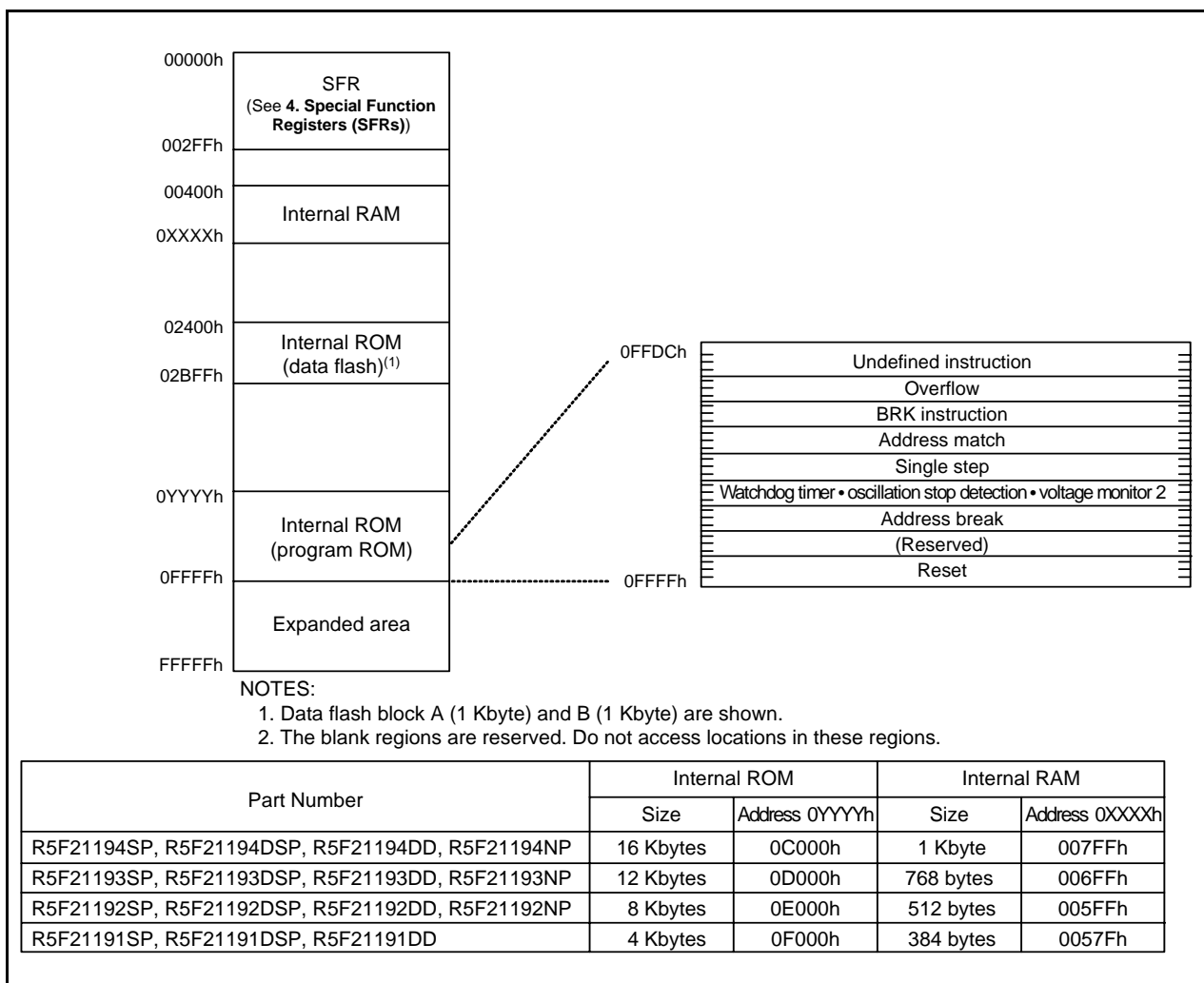

Figure 3.2 Memory Map of R8C/19 Group

## 4. Special Function Registers (SFRs)

An SFR (special function register) is a control register for a peripheral function. Tables 4.1 to 4.4 list the special function registers.

**Table 4.1 SFR Information (1)(1)**

Address	Register	Symbol	After reset
0000h			
0001h			
0002h			
0003h			
0004h	Processor Mode Register 0	PM0	00h
0005h	Processor Mode Register 1	PM1	00h
0006h	System Clock Control Register 0	CM0	01101000b
0007h	System Clock Control Register 1	CM1	00100000b
0008h			
0009h	Address Match Interrupt Enable Register	AIER	00h
000Ah	Protect Register	PRCR	00h
000Bh			
000Ch	Oscillation Stop Detection Register	OCD	00000100b
000Dh	Watchdog Timer Reset Register	WDTR	XXh
000Eh	Watchdog Timer Start Register	WDTS	XXh
000Fh	Watchdog Timer Control Register	WDC	00011111b
0010h	Address Match Interrupt Register 0	RMAD0	00h
0011h			00h
0012h			X0h
0013h			
0014h	Address Match Interrupt Register 1	RMAD1	00h
0015h			00h
0016h			X0h
0017h			
0018h			
0019h			
001Ah			
001Bh			
001Ch	Count Source Protection Mode Register	CSPR	00h
001Dh			
001Eh	INT0 Input Filter Select Register	INT0F	00h
001Fh			
0020h	High-Speed On-Chip Oscillator Control Register 0	HRA0	00h
0021h	High-Speed On-Chip Oscillator Control Register 1	HRA1	When shipping
0022h	High-Speed On-Chip Oscillator Control Register 2	HRA2	00h
0023h			
0024h			
0025h			
0026h			
0027h			
0028h			
0029h			
002Ah			
002Bh			
002Ch			
002Dh			
002Eh			
002Fh			
0030h			
0031h	Voltage Detection Register 1 <sup>(2)</sup>	VCA1	00001000b
0032h	Voltage Detection Register 2 <sup>(2)</sup>	VCA2	00h <sup>(3)</sup> 01000000b <sup>(4)</sup>
0033h			
0034h			
0035h			
0036h	Voltage Monitor 1 Circuit Control Register <sup>(2)</sup>	VW1C	0000X000b <sup>(3)</sup> 0100X001b <sup>(4)</sup>
0037h	Voltage Monitor 2 Circuit Control Register <sup>(5)</sup>	VW2C	00h
0038h			
0039h			
003Ah			
003Bh			
003Ch			
003Dh			
003Eh			
003Fh			

X: Undefined

NOTES:

1. The blank regions are reserved. Do not access locations in these regions.
2. Software reset, watchdog timer reset, and voltage monitor 2 reset do not affect this register.
3. After hardware reset.
4. After power-on reset or voltage monitor 1 reset.
5. Software reset, watchdog timer reset, and voltage monitor 2 reset do not affect b2 and b3.

**Table 4.2 SFR Information (2)<sup>(1)</sup>**

Address	Register	Symbol	After reset
0040h			
0041h			
0042h			
0043h			
0044h			
0045h			
0046h			
0047h			
0048h			
0049h			
004Ah			
004Bh			
004Ch			
004Dh	Key Input Interrupt Control Register	KUPIC	XXXXX000b
004Eh	Comparator Conversion Interrupt Control Register	ADIC	XXXXX000b
004Fh			
0050h	Compare 1 Interrupt Control Register	CMP1IC	XXXXX000b
0051h	UART0 Transmit Interrupt Control Register	S0TIC	XXXXX000b
0052h	UART0 Receive Interrupt Control Register	S0RIC	XXXXX000b
0053h	UART1 Transmit Interrupt Control Register	S1TIC	XXXXX000b
0054h	UART1 Receive Interrupt Control Register	S1RIC	XXXXX000b
0055h			
0056h	Timer X Interrupt Control Register	TXIC	XXXXX000b
0057h			
0058h	Timer Z Interrupt Control Register	TZIC	XXXXX000b
0059h	INT1 Interrupt Control Register	INT1IC	XXXXX000b
005Ah	INT3 Interrupt Control Register	INT3IC	XXXXX000b
005Bh	Timer C Interrupt Control Register	TCIC	XXXXX000b
005Ch	Compare 0 Interrupt Control Register	CMP0IC	XXXXX000b
005Dh	INT0 Interrupt Control Register	INT0IC	XX00X000b
005Eh			
005Fh			
0060h			
0061h			
0062h			
0063h			
0064h			
0065h			
0066h			
0067h			
0068h			
0069h			
006Ah			
006Bh			
006Ch			
006Dh			
006Eh			
006Fh			
0070h			
0071h			
0072h			
0073h			
0074h			
0075h			
0076h			
0077h			
0078h			
0079h			
007Ah			
007Bh			
007Ch			
007Dh			
007Eh			
007Fh			

X: Undefined

NOTE:

1. The blank regions are reserved. Do not access locations in these regions.

**Table 4.3 SFR Information (3)(1)**

Address	Register	Symbol	After reset
0080h	Timer Z Mode Register	TZMR	00h
0081h			
0082h			
0083h			
0084h	Timer Z Waveform Output Control Register	PUM	00h
0085h	Prescaler Z Register	PREZ	FFh
0086h	Timer Z Secondary Register	TZSC	FFh
0087h	Timer Z Primary Register	TZPR	FFh
0088h			
0089h			
008Ah	Timer Z Output Control Register	TZOC	00h
008Bh	Timer X Mode Register	TXMR	00h
008Ch	Prescaler X Register	PREX	FFh
008Dh	Timer X Register	TX	FFh
008Eh	Timer Count Source Setting Register	TCSS	00h
008Fh			
0090h	Timer C Register	TC	00h
0091h			00h
0092h			
0093h			
0094h			
0095h			
0096h	External Input Enable Register	INTEN	00h
0097h			
0098h	Key Input Enable Register	KIEN	00h
0099h			
009Ah	Timer C Control Register 0	TCC0	00h
009Bh	Timer C Control Register 1	TCC1	00h
009Ch	Capture, Compare 0 Register	TM0	00h
009Dh			00h <sup>(2)</sup>
009Eh	Compare 1 Register	TM1	FFh
009Fh			FFh
00A0h	UART0 Transmit/Receive Mode Register	U0MR	00h
00A1h	UART0 Bit Rate Register	U0BRG	XXh
00A2h	UART0 Transmit Buffer Register	U0TB	XXh
00A3h			XXh
00A4h	UART0 Transmit/Receive Control Register 0	U0C0	00001000b
00A5h	UART0 Transmit/Receive Control Register 1	U0C1	00000010b
00A6h	UART0 Receive Buffer Register	U0RB	XXh
00A7h			XXh
00A8h	UART1 Transmit/Receive Mode Register	U1MR	00h
00A9h	UART1 Bit Rate Register	U1BRG	XXh
00AAh	UART1 Transmit Buffer Register	U1TB	XXh
00ABh			XXh
00ACh	UART1 Transmit/Receive Control Register 0	U1C0	00001000b
00ADh	UART1 Transmit/Receive Control Register 1	U1C1	00000010b
00AEh	UART1 Receive Buffer Register	U1RB	XXh
00AFh			XXh
00B0h	UART Transmit/Receive Control Register 2	UCON	00h
00B1h			
00B2h			
00B3h			
00B4h			
00B5h			
00B6h			
00B7h			
00B8h			
00B9h			
00BAh			
00BBh			
00BCh			
00BDh			
00BEh			
00BFh			

X: Undefined

## NOTES:

1. The blank regions are reserved. Do not access locations in these regions.
2. When the output compare mode is selected (the TCC13 bit in the TCC1 register = 1), the value is set to FFFF<sub>16</sub>.

**Table 4.4 SFR Information (4)<sup>(1)</sup>**

Address	Register	Symbol	After reset
00C0h	A/D Register	AD	XXh
00C1h			
00C2h			
00C3h			
00C4h			
00C5h			
00C6h			
00C7h			
00C8h			
00C9h			
00CAh			
00CBh			
00CCh			
00CDh			
00CEh			
00CFh			
00D0h			
00D1h			
00D2h			
00D3h			
00D4h	A/D Control Register 2	ADCON2	00h
00D5h			
00D6h	A/D Control Register 0	ADCON0	00000XXb
00D7h	A/D Control Register 1	ADCON1	00h
00D8h			
00D9h			
00DAh			
00DBh			
00DCh			
00DDh			
00DEh			
00DFh			
00E0h			
00E1h	Port P1 Register	P1	XXh
00E2h			
00E3h	Port P1 Direction Register	PD1	00h
00E4h			
00E5h	Port P3 Register	P3	XXh
00E6h			
00E7h	Port P3 Direction Register	PD3	00h
00E8h	Port P4 Register	P4	XXh
00E9h			
00EAh	Port P4 Direction Register	PD4	00h
00EBh			
00ECh			
00EDh			
00EEh			
00EFh			
00F0h			
00F1h			
00F2h			
00F3h			
00F4h			
00F5h			
00F6h			
00F7h			
00F8h			
00F9h			
00FAh			
00FBh			
00FCh	Pull-Up Control Register 0	PUR0	00XX0000b
00FDh	Pull-Up Control Register 1	PUR1	XXXXXX0Xb
00FEh	Port P1 Drive Capacity Control Register	DRR	00h
00FFh	Timer C Output Control Register	TCOUT	00h
01B3h	Flash Memory Control Register 4	FMR4	01000000b
01B4h			
01B5h	Flash Memory Control Register 1	FMR1	1000000Xb
01B6h			
01B7h	Flash Memory Control Register 0	FMR0	00000001b
0FFFh	Optional Function Select Register	OFS	(Note 2)

X: Undefined

## NOTES:

1. The blank regions, 0100h to 01B2h and 01B8h to 02FFh are all reserved. Do not access locations in these regions.
2. The OFS register cannot be changed by a program. Use a flash programmer to write to it.

## 5. Electrical Characteristics

**Table 5.1 Absolute Maximum Ratings**

Symbol	Parameter	Condition	Rated Value	Unit
V <sub>CC</sub>	Supply voltage	V <sub>CC</sub> = AV <sub>CC</sub>	-0.3 to 6.5	V
AV <sub>CC</sub>	Analog supply voltage	V <sub>CC</sub> = AV <sub>CC</sub>	-0.3 to 6.5	V
V <sub>I</sub>	Input voltage		-0.3 to V <sub>CC</sub> +0.3	V
V <sub>O</sub>	Output voltage		-0.3 to V <sub>CC</sub> +0.3	V
P <sub>d</sub>	Power dissipation	T <sub>opr</sub> = 25°C	300	mW
T <sub>opr</sub>	Operating ambient temperature		-20 to 85 / -40 to 85 (D version)	°C
T <sub>stg</sub>	Storage temperature		-65 to 150	°C

**Table 5.2 Recommended Operating Conditions**

Symbol	Parameter		Conditions	Standard			Unit
				Min.	Typ.	Max.	
V <sub>CC</sub>	Supply voltage			2.7	–	5.5	V
AV <sub>CC</sub>	Analog supply voltage			–	V <sub>CC</sub>	–	V
V <sub>SS</sub>	Supply voltage			–	0	–	V
AV <sub>SS</sub>	Analog supply voltage			–	0	–	V
V <sub>IH</sub>	Input “H” voltage			0.8V <sub>CC</sub>	–	V <sub>CC</sub>	V
V <sub>IL</sub>	Input “L” voltage			0	–	0.2V <sub>CC</sub>	V
I <sub>OH(sum)</sub>	Peak sum output “H” current	Sum of all pins I <sub>OH</sub> (peak)		–	–	-60	mA
I <sub>OH(peak)</sub>	Peak output “H” current			–	–	-10	mA
I <sub>OH(avg)</sub>	Average output “H” current			–	–	-5	mA
I <sub>OL(sum)</sub>	Peak sum output “L” currents	Sum of all pins I <sub>OL</sub> (peak)		–	–	60	mA
I <sub>OL(peak)</sub>	Peak output “L” currents	Except P1_0 to P1_3		–	–	10	mA
		P1_0 to P1_3	Drive capacity HIGH	–	–	30	mA
			Drive capacity LOW	–	–	10	mA
I <sub>OL(avg)</sub>	Average output “L” current	Except P1_0 to P1_3		–	–	5	mA
		P1_0 to P1_3	Drive capacity HIGH	–	–	15	mA
			Drive capacity LOW	–	–	5	mA
f <sub>(XIN)</sub>	Main clock input oscillation frequency		3.0 V ≤ V <sub>CC</sub> ≤ 5.5 V	0	–	20	MHz
			2.7 V ≤ V <sub>CC</sub> < 3.0 V	0	–	10	MHz

**NOTES:**

- V<sub>CC</sub> = 2.7 to 5.5 V at T<sub>opr</sub> = -20 to 85 °C / -40 to 85 °C, unless otherwise specified.
- Typical values when average output current is 100 ms.

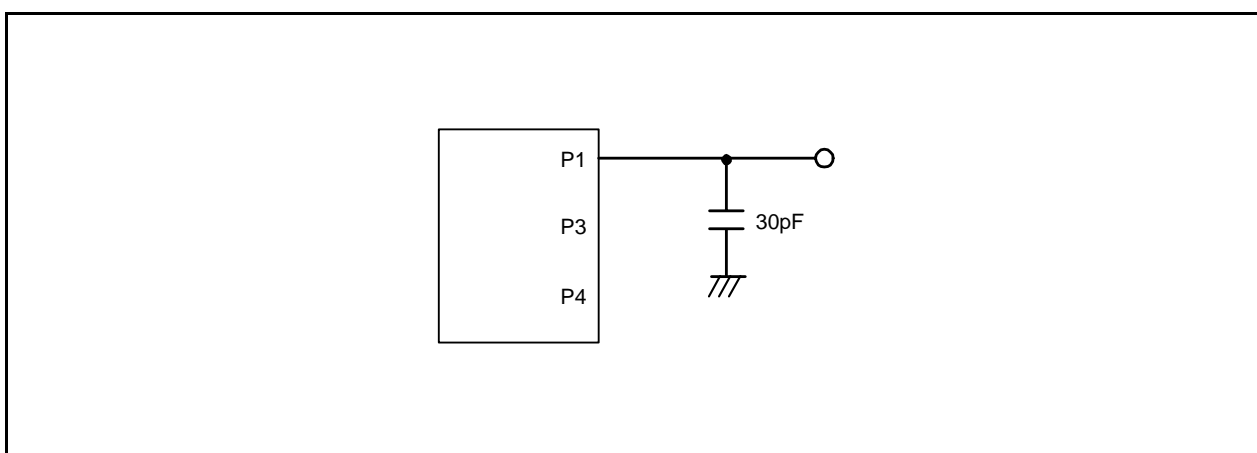

**Table 5.3 Comparator Characteristics**

Symbol	Parameter	Conditions	Standard			Unit
			Min.	Typ.	Max.	
–	Resolution		–	–	1	Bit
–	Absolute accuracy	$\phi_{AD} = 10 \text{ MHz}^{(3)}$	–	–	$\pm 20$	mV
$t_{conv}$	Conversion time	$\phi_{AD} = 10 \text{ MHz}^{(3)}$	1	–	–	$\mu\text{s}$
$V_{ref}$	Reference voltage		0	–	$AV_{CC}$	V
$V_{IA}$	Analog input voltage		0	–	$AV_{CC}$	V
–	Comparator conversion operating clock frequency <sup>(2)</sup>		1	–	10	MHz

## NOTES:

1.  $V_{CC} = 2.7$  to  $5.5 \text{ V}$  at  $T_{opr} = -20$  to  $85 \text{ }^\circ\text{C}$  /  $-40$  to  $85 \text{ }^\circ\text{C}$ , unless otherwise specified.
2. If  $f_1$  exceeds  $10 \text{ MHz}$ , divided  $f_1$  and ensure the comparator conversion operating clock frequency ( $\phi_{AD}$ ) is  $10 \text{ MHz}$  or below.
3. If  $AV_{CC}$  is less than  $4.2 \text{ V}$ , divided  $f_1$  and ensure the comparator conversion operating clock frequency ( $\phi_{AD}$ ) is  $f_1/2$  or below.

**Figure 5.1 Port P1, P3, and P4 Measurement Circuit**

**Table 5.4 Flash Memory (Program ROM) Electrical Characteristics**

Symbol	Parameter	Conditions	Standard			Unit
			Min.	Typ.	Max.	
–	Program/erase endurance <sup>(2)</sup>	R8C/18 Group	100 <sup>(3)</sup>	–	–	times
		R8C/19 Group	1,000 <sup>(3)</sup>	–	–	times
–	Byte program time		–	50	400	μs
–	Block erase time		–	0.4	9	s
t <sub>d</sub> (SR-SUS)	Time delay from suspend request until suspend		–	–	97+CPU clock × 6 cycles	μs
–	Interval from erase start/restart until following suspend request		650	–	–	μs
–	Interval from program start/restart until following suspend request		0	–	–	ns
–	Time from suspend until program/erase restart		–	–	3+CPU clock × 4 cycles	μs
–	Program, erase voltage		2.7	–	5.5	V
–	Read voltage		2.7	–	5.5	V
–	Program, erase temperature		0	–	60	°C
–	Data hold time <sup>(8)</sup>	Ambient temperature = 55 °C	20	–	–	year

## NOTES:

1. V<sub>CC</sub> = 2.7 to 5.5 V at T<sub>opr</sub> = 0 to 60 °C, unless otherwise specified.
2. Definition of programming/erasure endurance  
The programming and erasure endurance is defined on a per-block basis.  
If the programming and erasure endurance is n (n = 100 or 10,000), each block can be erased n times. For example, if 1,024 1-byte writes are performed to block A, a 1 Kbyte block, and then the block is erased, the programming/erasure endurance still stands at one. However, the same address must not be programmed more than once per erase operation (overwriting prohibited).
3. Endurance to guarantee all electrical characteristics after program and erase. (1 to Min. value can be guaranteed).
4. If emergency processing is required, a suspend request can be generated independent of this characteristic. In that case the normal time delay to Suspend can be applied to the request. However, we recommend that a suspend request with an interval of less than 650 μs is only used once because, if the suspend state continues, erasure cannot operate and the incidence of erasure error rises.
5. In a system that executes multiple programming operations, the actual erasure count can be reduced by writing to sequential addresses in turn so that as much of the block as possible is used up before performing an erase operation. For example, when programming groups of 16 bytes, the effective number of rewrites can be minimized by programming up to 128 groups before erasing them all in one operation. In addition, averaging the number of erase operations between block A and block B can further reduce the effective number of rewrites. It is also advisable to retain data on the erase count of each block and limit the number of erase operations to a certain number.
6. If an error occurs during block erase, attempt to execute the clear status register command, then execute the block erase command at least three times until the erase error does not occur.
7. Customers desiring programming/erasure failure rate information should contact their Renesas technical support representative.
8. The data hold time includes time that the power supply is off or the clock is not supplied.

**Table 5.5 Flash Memory (Data flash Block A, Block B) Electrical Characteristics**

Symbol	Parameter	Conditions	Standard			Unit
			Min.	Typ.	Max.	
–	Program/erase endurance <sup>(2)</sup>		10,000 <sup>(3)</sup>	–	–	times
–	Byte program time (Program/erase endurance ≤ 1,000 times)		–	50	400	μs
–	Byte program time (Program/erase endurance > 1,000 times)		–	65	–	μs
–	Block erase time (Program/erase endurance ≤ 1,000 times)		–	0.2	9	s
–	Block erase time (Program/erase endurance > 1,000 times)		–	0.3	–	s
td(SR-SUS)	Time delay from suspend request until suspend		–	–	97+CPU clock x 6 cycles	μs
–	Interval from erase start/restart until following suspend request		650	–	–	μs
–	Interval from program start/restart until following suspend request		0	–	–	ns
–	Time from suspend until program/erase restart		–	–	3+CPU clock x 4 cycles	μs
–	Program, erase voltage		2.7	–	5.5	V
–	Read voltage		2.7	–	5.5	V
–	Program, erase temperature		-20 <sup>(8)</sup>	–	85	°C
–	Data hold time <sup>(9)</sup>	Ambient temperature = 55 °C	20	–	–	year

## NOTES:

- V<sub>CC</sub> = 2.7 to 5.5 V at T<sub>opr</sub> = -20 to 85 °C / -40 to 85 °C, unless otherwise specified.
- Definition of programming/erasure endurance  
The programming and erasure endurance is defined on a per-block basis.  
If the programming and erasure endurance is n (n = 100 or 10,000), each block can be erased n times. For example, if 1,024 1-byte writes are performed to block A, a 1 Kbyte block, and then the block is erased, the programming/erasure endurance still stands at one. However, the same address must not be programmed more than once per erase operation (overwriting prohibited).
- Endurance to guarantee all electrical characteristics after program and erase. (1 to Min. value can be guaranteed).
- If emergency processing is required, a suspend request can be generated independent of this characteristic. In that case the normal time delay to suspend can be applied to the request. However, we recommend that a suspend request with an interval of less than 650 μs is only used once because, if the suspend state continues, erasure cannot operate and the incidence of erasure error rises.
- In a system that executes multiple programming operations, the actual erasure count can be reduced by writing to sequential addresses in turn so that as much of the block as possible is used up before performing an erase operation. For example, when programming groups of 16 bytes, the effective number of rewrites can be minimized by programming up to 128 groups before erasing them all in one operation. It is also advisable to retain data on the erase count of each block and limit the number of erase operations to a certain number.
- If an error occurs during block erase, attempt to execute the clear status register command, then execute the block erase command at least three times until the erase error does not occur.
- Customers desiring programming/erasure failure rate information should contact their Renesas technical support representative.
- 40 °C for D version.
- The data hold time includes time that the power supply is off or the clock is not supplied.

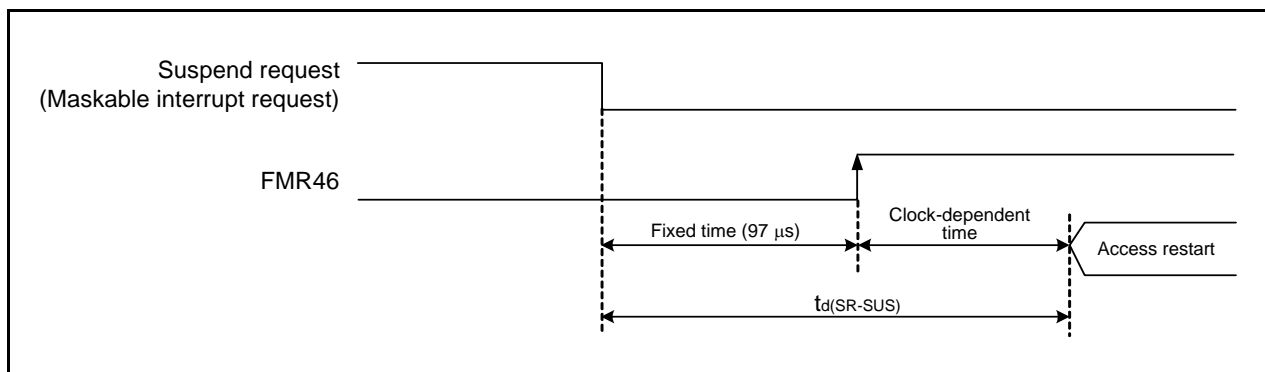
**Figure 5.2 Transition Time to Suspend**

**Table 5.6 Voltage Detection 1 Circuit Electrical Characteristics**

Symbol	Parameter	Condition	Standard			Unit
			Min.	Typ.	Max.	
V <sub>det1</sub>	Voltage detection level <sup>(3)</sup>		2.70	2.85	3.00	V
–	Voltage detection circuit self power consumption	VCA26 = 1, V <sub>CC</sub> = 5.0 V	–	600	–	nA
t <sub>d(E-A)</sub>	Waiting time until voltage detection circuit operation starts <sup>(2)</sup>		–	–	100	μs
V <sub>ccmin</sub>	MCU operating voltage minimum value		2.7	–	–	V

## NOTES:

1. The measurement condition is V<sub>CC</sub> = 2.7 V to 5.5 V and T<sub>opr</sub> = -40°C to 85 °C.
2. Necessary time until the voltage detection circuit operates when setting to 1 again after setting the VCA26 bit in the VCA2 register to 0.
3. Ensure that V<sub>det2</sub> > V<sub>det1</sub>.

**Table 5.7 Voltage Detection 2 Circuit Electrical Characteristics**

Symbol	Parameter	Condition	Standard			Unit
			Min.	Typ.	Max.	
V <sub>det2</sub>	Voltage detection level <sup>(4)</sup>		3.00	3.30	3.60	V
–	Voltage monitor 2 interrupt request generation time <sup>(2)</sup>		–	40	–	μs
–	Voltage detection circuit self power consumption	VCA27 = 1, V <sub>CC</sub> = 5.0 V	–	600	–	nA
t <sub>d(E-A)</sub>	Waiting time until voltage detection circuit operation starts <sup>(3)</sup>		–	–	100	μs

## NOTES:

1. The measurement condition is V<sub>CC</sub> = 2.7 V to 5.5 V and T<sub>opr</sub> = -40°C to 85 °C.
2. Time until the voltage monitor 2 interrupt request is generated after the voltage passes V<sub>det1</sub>.
3. Necessary time until the voltage detection circuit operates when setting to 1 again after setting the VCA27 bit in the VCA2 register to 0.
4. Ensure that V<sub>det2</sub> > V<sub>det1</sub>.

**Table 5.8 Reset Circuit Electrical Characteristics (When Using Voltage Monitor 1 Reset)**

Symbol	Parameter	Condition	Standard			Unit
			Min.	Typ.	Max.	
$V_{por2}$	Power-on reset valid voltage	$-20^{\circ}\text{C} \leq T_{opr} \leq 85^{\circ}\text{C}$	–	–	$V_{det1}$	V
$t_{w(V_{por2}-V_{det1})}$	Supply voltage rising time when power-on reset is deasserted <sup>(1)</sup>	$-20^{\circ}\text{C} \leq T_{opr} \leq 85^{\circ}\text{C}$ , $t_{w(por2)} \geq 0\text{s}^{(3)}$	–	–	100	ms

## NOTES:

1. This condition is not applicable when using with  $V_{cc} \geq 1.0\text{ V}$ .
2. When turning power on after the time to hold the external power below effective voltage ( $V_{por1}$ ) exceeds 10 s, refer to **Table 5.9 Reset Circuit Electrical Characteristics (When Not Using Voltage Monitor 1 Reset)**.
3.  $t_{w(por2)}$  is the time to hold the external power below effective voltage ( $V_{por2}$ ).

**Table 5.9 Reset Circuit Electrical Characteristics (When Not Using Voltage Monitor 1 Reset)**

Symbol	Parameter	Condition	Standard			Unit
			Min.	Typ.	Max.	
$V_{por1}$	Power-on reset valid voltage	$-20^{\circ}\text{C} \leq T_{opr} \leq 85^{\circ}\text{C}$	–	–	0.1	V
$t_{w(V_{por1}-V_{det1})}$	Supply voltage rising time when power-on reset is deasserted	$0^{\circ}\text{C} \leq T_{opr} \leq 85^{\circ}\text{C}$ , $t_{w(por1)} \geq 10\text{ s}^{(2)}$	–	–	100	ms
$t_{w(V_{por1}-V_{det1})}$	Supply voltage rising time when power-on reset is deasserted	$-20^{\circ}\text{C} \leq T_{opr} < 0^{\circ}\text{C}$ , $t_{w(por1)} \geq 30\text{ s}^{(2)}$	–	–	100	ms
$t_{w(V_{por1}-V_{det1})}$	Supply voltage rising time when power-on reset is deasserted	$-20^{\circ}\text{C} \leq T_{opr} < 0^{\circ}\text{C}$ , $t_{w(por1)} \geq 10\text{ s}^{(2)}$	–	–	1	ms
$t_{w(V_{por1}-V_{det1})}$	Supply voltage rising time when power-on reset is deasserted	$0^{\circ}\text{C} \leq T_{opr} \leq 85^{\circ}\text{C}$ , $t_{w(por1)} \geq 1\text{ s}^{(2)}$	–	–	0.5	ms

## NOTES:

1. When not using voltage monitor 1, use with  $V_{cc} \geq 2.7\text{ V}$ .
2.  $t_{w(por1)}$  is the time to hold the external power below effective voltage ( $V_{por1}$ ).

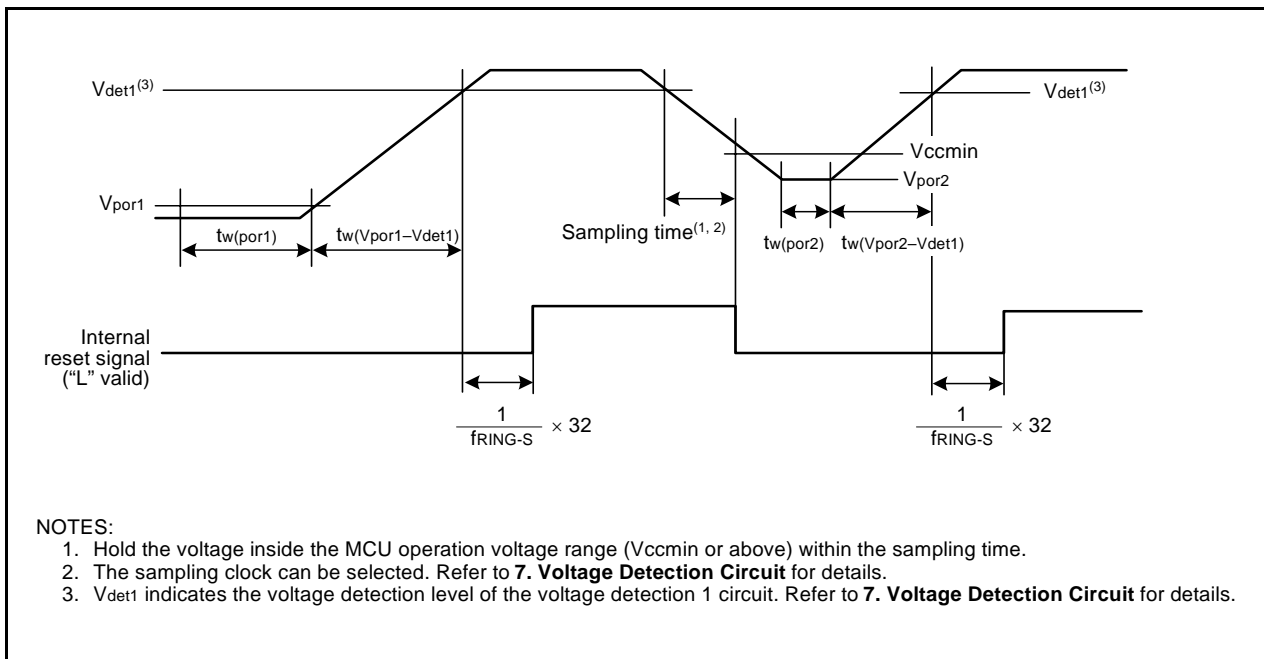
**Figure 5.3 Reset Circuit Electrical Characteristics**

**Table 5.10 High-speed On-Chip Oscillator Circuit Electrical Characteristics**

Symbol	Parameter	Condition	Standard			Unit
			Min.	Typ.	Max.	
–	High-speed on-chip oscillator frequency when the reset is deasserted	$V_{CC} = 5.0 \text{ V}$ , $T_{opr} = 25 \text{ }^\circ\text{C}$	–	8	–	MHz
–	High-speed on-chip oscillator frequency temperature supply voltage dependence <sup>(2)</sup>	0 to +60 $^\circ\text{C}/5 \text{ V} \pm 5 \%$ <sup>(3)</sup>	7.76	–	8.24	MHz
		-20 to +85 $^\circ\text{C}/2.7 \text{ to } 5.5 \text{ V}$ <sup>(3)</sup>	7.68	–	8.32	MHz
		-40 to +85 $^\circ\text{C}/2.7 \text{ to } 5.5 \text{ V}$ <sup>(3)</sup>	7.44	–	8.32	MHz

## NOTES:

1. The measurement condition is  $V_{CC} = 5.0 \text{ V}$  and  $T_{opr} = 25 \text{ }^\circ\text{C}$ .
2. Refer to **10.6.4 High-Speed On-Chip Oscillator Clock** for notes on high-speed on-chip oscillator clock.
3. The standard value shows when the HRA1 register is assumed as the value in shipping and the HRA2 register value is set to 00h.

**Table 5.11 Power Supply Circuit Timing Characteristics**

Symbol	Parameter	Condition	Standard			Unit
			Min.	Typ.	Max.	
$t_{d(P-R)}$	Time for internal power supply stabilization during power-on <sup>(2)</sup>		1	–	2000	$\mu\text{s}$
$t_{d(R-S)}$	STOP exit time <sup>(3)</sup>		–	–	150	$\mu\text{s}$

## NOTES:

1. The measurement condition is  $V_{CC} = 2.7 \text{ to } 5.5 \text{ V}$  and  $T_{opr} = 25 \text{ }^\circ\text{C}$ .
2. Waiting time until the internal power supply generation circuit stabilizes during power-on.
3. Time until CPU clock supply starts after the interrupt is acknowledged to exit stop mode.

**Table 5.12 Electrical Characteristics (1) [V<sub>CC</sub> = 5 V]**

Symbol	Parameter		Condition		Standard			Unit
					Min.	Typ.	Max.	
V <sub>OH</sub>	Output "H" voltage	Except X <sub>OUT</sub>	I <sub>OH</sub> = -5 mA		V <sub>CC</sub> - 2.0	-	V <sub>CC</sub>	V
			I <sub>OH</sub> = -200 μA		V <sub>CC</sub> - 0.3	-	V <sub>CC</sub>	V
		X <sub>OUT</sub>	Drive capacity HIGH	I <sub>OH</sub> = -1 mA	V <sub>CC</sub> - 2.0	-	V <sub>CC</sub>	V
			Drive capacity LOW	I <sub>OH</sub> = -500 μA	V <sub>CC</sub> - 2.0	-	V <sub>CC</sub>	V
V <sub>OL</sub>	Output "L" voltage	Except P1_0 to P1_3, X <sub>OUT</sub>	I <sub>OL</sub> = 5 mA		-	-	2.0	V
			I <sub>OL</sub> = 200 μA		-	-	0.45	V
		P1_0 to P1_3	Drive capacity HIGH	I <sub>OL</sub> = 15 mA	-	-	2.0	V
			Drive capacity LOW	I <sub>OL</sub> = 5 mA	-	-	2.0	V
			Drive capacity LOW	I <sub>OL</sub> = 200 μA	-	-	0.45	V
		X <sub>OUT</sub>	Drive capacity HIGH	I <sub>OL</sub> = 1 mA	-	-	2.0	V
			Drive capacity LOW	I <sub>OL</sub> = 500 μA	-	-	2.0	V
		V <sub>T+</sub> -V <sub>T-</sub>	Hysteresis	INT0, INT1, INT2, INT3, KI0, KI1, KI2, KI3, CNTR0, CNTR1, TCIN, RXD0			0.2	-
RESET				0.2	-	2.2	V	
I <sub>IH</sub>	Input "H" current		V <sub>I</sub> = 5 V		-	-	5.0	μA
I <sub>IL</sub>	Input "L" current		V <sub>I</sub> = 0 V		-	-	-5.0	μA
R <sub>PULLUP</sub>	Pull-up resistance		V <sub>I</sub> = 0 V		30	50	167	kΩ
R <sub>FXIN</sub>	Feedback resistance	XIN			-	1.0	-	MΩ
f <sub>RING-S</sub>	Low-speed on-chip oscillator frequency				40	125	250	kHz
V <sub>RAM</sub>	RAM hold voltage		During stop mode		2.0	-	-	V

## NOTE:

- V<sub>CC</sub> = 4.2 to 5.5 V at T<sub>opr</sub> = -20 to 85 °C / -40 to 85 °C, f(XIN) = 20 MHz, unless otherwise specified.

**Table 5.13 Electrical Characteristics (2) [V<sub>CC</sub> = 5 V] (T<sub>OPR</sub> = -40 to 85 °C, unless otherwise specified.)**

Symbol	Parameter	Condition	Standard			Unit	
			Min.	Typ.	Max.		
I <sub>CC</sub>	Power supply current (V <sub>CC</sub> = 3.3 to 5.5 V) Single-chip mode, output pins are open, other pins are V <sub>SS</sub> , comparator is stopped	High-speed mode	XIN = 20 MHz (square wave) High-speed on-chip oscillator off Low-speed on-chip oscillator on = 125 kHz No division	–	9	15	mA
			XIN = 16 MHz (square wave) High-speed on-chip oscillator off Low-speed on-chip oscillator on = 125 kHz No division	–	8	14	mA
			XIN = 10 MHz (square wave) High-speed on-chip oscillator off Low-speed on-chip oscillator on = 125 kHz No division	–	5	–	mA
		Medium-speed mode	XIN = 20 MHz (square wave) High-speed on-chip oscillator off Low-speed on-chip oscillator on = 125 kHz Divide-by-8	–	4	–	mA
			XIN = 16 MHz (square wave) High-speed on-chip oscillator off Low-speed on-chip oscillator on = 125 kHz Divide-by-8	–	3	–	mA
			XIN = 10 MHz (square wave) High-speed on-chip oscillator off Low-speed on-chip oscillator on = 125 kHz Divide-by-8	–	2	–	mA
		High-speed on-chip oscillator mode	Main clock off High-speed on-chip oscillator on = 8 MHz Low-speed on-chip oscillator on = 125 kHz No division	–	4	8	mA
			Main clock off High-speed on-chip oscillator on = 8 MHz Low-speed on-chip oscillator on = 125 kHz Divide-by-8	–	1.5	–	mA
		Low-speed on-chip oscillator mode	Main clock off High-speed on-chip oscillator off Low-speed on-chip oscillator on = 125 kHz Divide-by-8 FMR47 = 1	–	110	300	μA
		Wait mode	Main clock off High-speed on-chip oscillator off Low-speed on-chip oscillator on = 125 kHz While a WAIT instruction is executed Peripheral clock operation VCA27 = VCA26 = 0	–	40	80	μA
		Wait mode	Main clock off High-speed on-chip oscillator off Low-speed on-chip oscillator on = 125 kHz While a WAIT instruction is executed Peripheral clock off VCA27 = VCA26 = 0	–	38	76	μA
		Stop mode	Main clock off, T <sub>OPR</sub> = 25 °C High-speed on-chip oscillator off Low-speed on-chip oscillator off CM10 = 1 Peripheral clock off VCA27 = VCA26 = 0	–	0.8	3.0	μA



**Timing Requirements****(Unless Otherwise Specified:  $V_{CC} = 5\text{ V}$ ,  $V_{SS} = 0\text{ V}$  at  $T_a = 25\text{ }^\circ\text{C}$ ) [ $V_{CC} = 5\text{ V}$ ]****Table 5.14 XIN Input**

Symbol	Parameter	Standard		Unit
		Min.	Max.	
$t_{c(XIN)}$	XIN input cycle time	50	–	ns
$t_{WH(XIN)}$	XIN input "H" width	25	–	ns
$t_{WL(XIN)}$	XIN input "L" width	25	–	ns

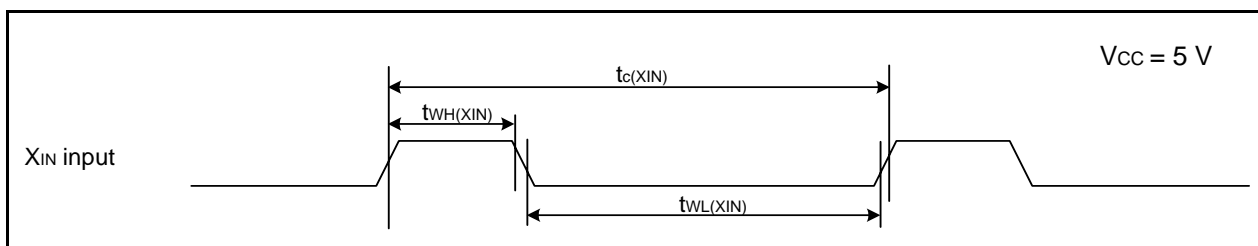
**Figure 5.4 XIN Input Timing Diagram when  $V_{CC} = 5\text{ V}$** **Table 5.15 CNTR0 Input, CNTR1 Input,  $\overline{INT1}$  Input**

Symbol	Parameter	Standard		Unit
		Min.	Max.	
$t_{c(CNTR0)}$	CNTR0 input cycle time	100	–	ns
$t_{WH(CNTR0)}$	CNTR0 input "H" width	40	–	ns
$t_{WL(CNTR0)}$	CNTR0 input "L" width	40	–	ns

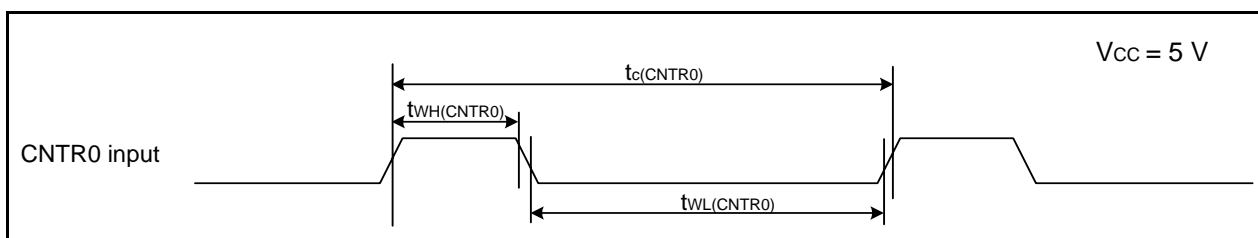
**Figure 5.5 CNTR0 Input, CNTR1 Input,  $\overline{INT1}$  Input Timing Diagram when  $V_{CC} = 5\text{ V}$** **Table 5.16 TCIN Input,  $\overline{INT3}$  Input**

Symbol	Parameter	Standard		Unit
		Min.	Max.	
$t_{c(TCIN)}$	TCIN input cycle time	400 <sup>(1)</sup>	–	ns
$t_{WH(TCIN)}$	TCIN input "H" width	200 <sup>(2)</sup>	–	ns
$t_{WL(TCIN)}$	TCIN input "L" width	200 <sup>(2)</sup>	–	ns

**NOTES:**

1. When using timer C input capture mode, adjust the cycle time to (1/timer C count source frequency x 3) or above.
2. When using timer C input capture mode, adjust the pulse width to (1/timer C count source frequency x 1.5) or above.

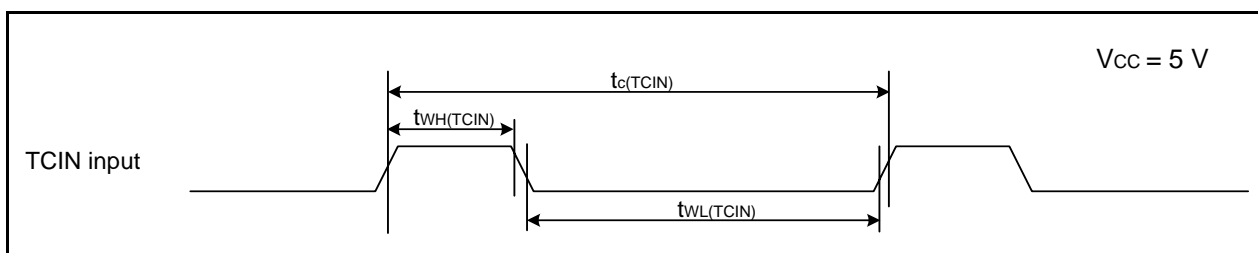
**Figure 5.6 TCIN Input,  $\overline{INT3}$  Input Timing Diagram when  $V_{CC} = 5\text{ V}$**

**Table 5.17 Serial Interface**

Symbol	Parameter	Standard		Unit
		Min.	Max.	
$t_{c(CK)}$	CLKi input cycle time	200	–	ns
$t_{w(CKH)}$	CLKi input “H” width	100	–	ns
$t_{w(CKL)}$	CLKi input “L” width	100	–	ns
$t_{d(C-Q)}$	TXDi output delay time	–	50	ns
$t_{h(C-Q)}$	TXDi hold time	0	–	ns
$t_{su(D-C)}$	RXDi input setup time	50	–	ns
$t_{h(C-D)}$	RXDi input hold time	90	–	ns

i = 0 or 1

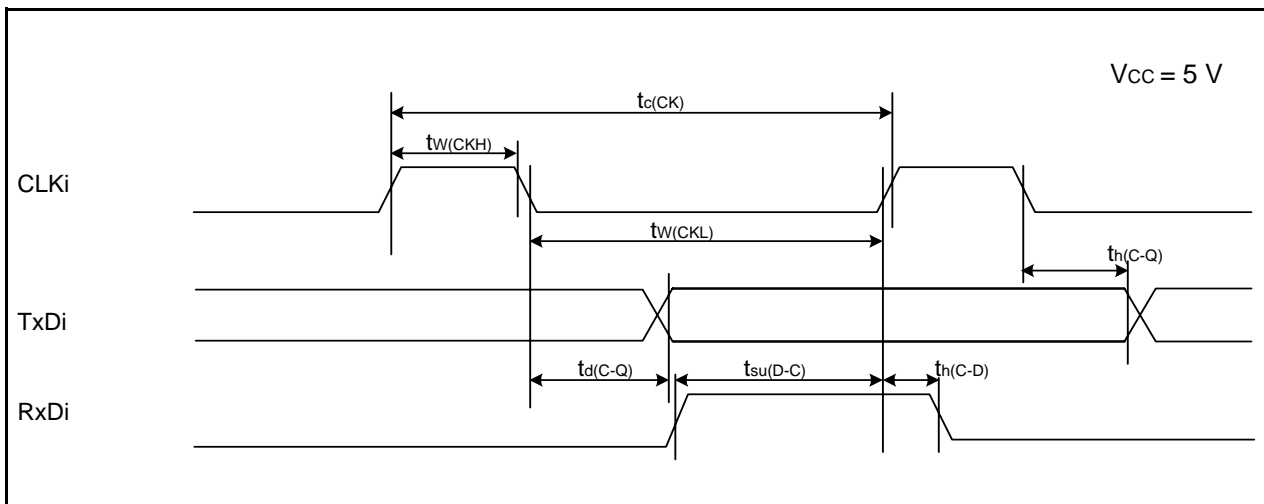
**Figure 5.7 Serial Interface Timing Diagram when Vcc = 5 V****Table 5.18 External Interrupt  $\overline{INT0}$  Input**

Symbol	Parameter	Standard		Unit
		Min.	Max.	
$t_{w(INH)}$	$\overline{INT0}$ input “H” width	250 <sup>(1)</sup>	–	ns
$t_{w(INL)}$	$\overline{INT0}$ input “L” width	250 <sup>(2)</sup>	–	ns

## NOTES:

- When selecting the digital filter by the  $\overline{INT0}$  input filter select bit, use an  $\overline{INT0}$  input HIGH width of either (1/digital filter clock frequency x 3) or the minimum value of standard, whichever is greater.
- When selecting the digital filter by the  $\overline{INT0}$  input filter select bit, use an  $\overline{INT0}$  input LOW width of either (1/digital filter clock frequency x 3) or the minimum value of standard, whichever is greater.

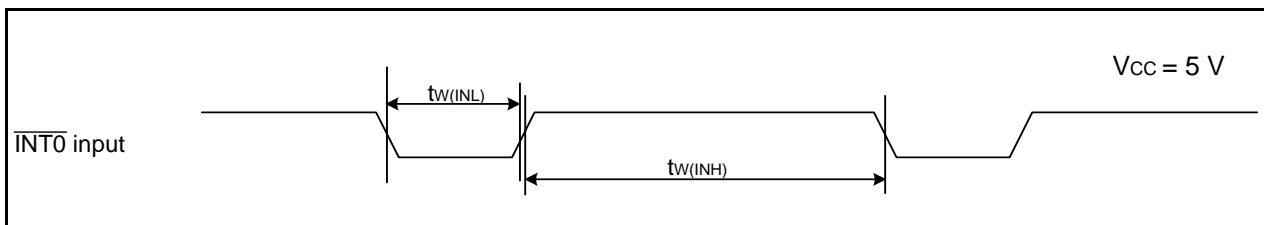
**Figure 5.8 External Interrupt  $\overline{INT0}$  Input Timing Diagram when Vcc = 5 V**

**Table 5.19 Electrical Characteristics (3) [V<sub>CC</sub> = 3V]**

Symbol	Parameter		Condition		Standard			Unit
					Min.	Typ.	Max.	
V <sub>OH</sub>	Output "H" voltage	Except X <sub>OUT</sub>	I <sub>OH</sub> = -1 mA		V <sub>CC</sub> - 0.5	-	V <sub>CC</sub>	V
		X <sub>OUT</sub>	Drive capacity HIGH	I <sub>OH</sub> = -0.1 mA	V <sub>CC</sub> - 0.5	-	V <sub>CC</sub>	V
			Drive capacity LOW	I <sub>OH</sub> = -50 μA	V <sub>CC</sub> - 0.5	-	V <sub>CC</sub>	V
V <sub>OL</sub>	Output "L" voltage	Except P1_0 to P1_3, X <sub>OUT</sub>	I <sub>OL</sub> = 1 mA		-	-	0.5	V
		P1_0 to P1_3	Drive capacity HIGH	I <sub>OL</sub> = 2 mA	-	-	0.5	V
			Drive capacity LOW	I <sub>OL</sub> = 1 mA	-	-	0.5	V
		X <sub>OUT</sub>	Drive capacity HIGH	I <sub>OL</sub> = 0.1 mA	-	-	0.5	V
			Drive capacity LOW	I <sub>OL</sub> = 50 μA	-	-	0.5	V
V <sub>T+</sub> -V <sub>T-</sub>	Hysteresis	$\overline{\text{INT0}}$ , $\overline{\text{INT1}}$ , $\overline{\text{INT2}}$ , $\overline{\text{INT3}}$ , K10, K11, K12, K13, CNTR0, CNTR1, TCIN, RXD0			0.2	-	0.8	V
		$\overline{\text{RESET}}$			0.2	-	1.8	V
I <sub>IH</sub>	Input "H" current		V <sub>I</sub> = 3 V		-	-	4.0	μA
I <sub>IL</sub>	Input "L" current		V <sub>I</sub> = 0 V		-	-	-4.0	μA
R <sub>PULLUP</sub>	Pull-up resistance		V <sub>I</sub> = 0 V		66	160	500	kΩ
R <sub>iXIN</sub>	Feedback resistance	X <sub>IN</sub>			-	3.0	-	MΩ
f <sub>FRING-S</sub>	Low-speed on-chip oscillator frequency				40	125	250	kHz
V <sub>RAM</sub>	RAM hold voltage		During stop mode		2.0	-	-	V

## NOTE:

- V<sub>CC</sub> = 2.7 to 3.3 V at T<sub>opr</sub> = -20 to 85 °C / -40 to 85 °C, f(X<sub>IN</sub>) = 10 MHz, unless otherwise specified.

**Table 5.20 Electrical Characteristics (4) [V<sub>CC</sub> = 3V] (Topr = -40 to 85 °C, unless otherwise specified.)**

Symbol	Parameter	Condition	Standard			Unit	
			Min.	Typ.	Max.		
I <sub>CC</sub>	Power supply current (V <sub>CC</sub> = 2.7 to 3.3 V) Single-chip mode, output pins are open, other pins are V <sub>SS</sub> , comparator is stopped	High-speed mode	XIN = 20 MHz (square wave) High-speed on-chip oscillator off Low-speed on-chip oscillator on = 125 kHz No division	–	8	13	mA
			XIN = 16 MHz (square wave) High-speed on-chip oscillator off Low-speed on-chip oscillator on = 125 kHz No division	–	7	12	mA
			XIN = 10 MHz (square wave) High-speed on-chip oscillator off Low-speed on-chip oscillator on = 125 kHz No division	–	5	–	mA
		Medium- speed mode	XIN = 20 MHz (square wave) High-speed on-chip oscillator off Low-speed on-chip oscillator on = 125 kHz Divide-by-8	–	3	–	mA
			XIN = 16 MHz (square wave) High-speed on-chip oscillator off Low-speed on-chip oscillator on = 125 kHz Divide-by-8	–	2.5	–	mA
			XIN = 10 MHz (square wave) High-speed on-chip oscillator off Low-speed on-chip oscillator on = 125 kHz Divide-by-8	–	1.6	–	mA
		High-speed on-chip oscillator mode	Main clock off High-speed on-chip oscillator on = 8 MHz Low-speed on-chip oscillator on = 125 kHz No division	–	3.5	7.5	mA
			Main clock off High-speed on-chip oscillator on = 8 MHz Low-speed on-chip oscillator on = 125 kHz Divide-by-8	–	1.5	–	mA
		Low-speed on-chip oscillator mode	Main clock off High-speed on-chip oscillator off Low-speed on-chip oscillator on = 125 kHz Divide-by-8 FMR47 = 1	–	100	280	μA
		Wait mode	Main clock off High-speed on-chip oscillator off Low-speed on-chip oscillator on = 125 kHz While a WAIT instruction is executed Peripheral clock operation VCA27 = VCA26 = 0	–	37	74	μA
		Wait mode	Main clock off High-speed on-chip oscillator off Low-speed on-chip oscillator on = 125 kHz While a WAIT instruction is executed Peripheral clock off VCA27 = VCA26 = 0	–	35	70	μA
		Stop mode	Main clock off, Topr = 25 °C High-speed on-chip oscillator off Low-speed on-chip oscillator off CM10 = 1 Peripheral clock off VCA27 = VCA26 = 0	–	0.7	3.0	μA

**Timing requirements****(Unless Otherwise Specified:  $V_{CC} = 3\text{ V}$ ,  $V_{SS} = 0\text{ V}$  at  $T_a = 25\text{ }^\circ\text{C}$ ) [ $V_{CC} = 3\text{ V}$ ]****Table 5.21 XIN Input**

Symbol	Parameter	Standard		Unit
		Min.	Max.	
$t_{c(XIN)}$	XIN input cycle time	100	–	ns
$t_{WH(XIN)}$	XIN input "H" width	40	–	ns
$t_{WL(XIN)}$	XIN input "L" width	40	–	ns

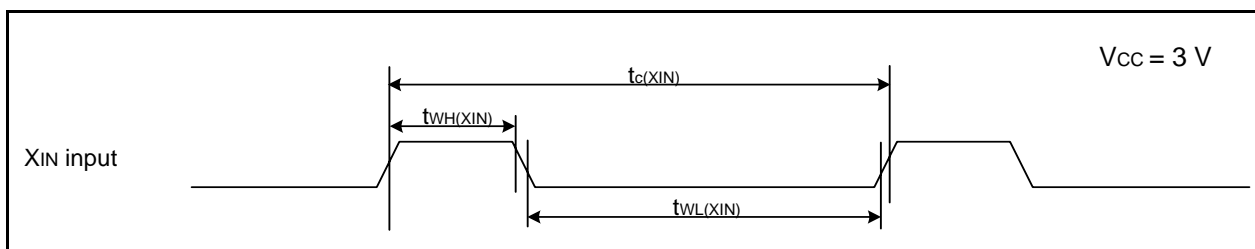
**Figure 5.9 XIN Input Timing Diagram when  $V_{CC} = 3\text{ V}$** **Table 5.22 CNTR0 Input, CNTR1 Input,  $\overline{INT1}$  Input**

Symbol	Parameter	Standard		Unit
		Min.	Max.	
$t_{c(CNTR0)}$	CNTR0 input cycle time	300	–	ns
$t_{WH(CNTR0)}$	CNTR0 input "H" width	120	–	ns
$t_{WL(CNTR0)}$	CNTR0 input "L" width	120	–	ns

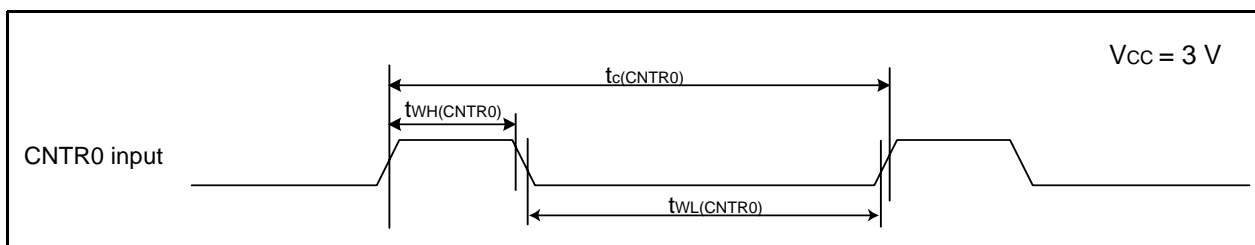
**Figure 5.10 CNTR0 Input, CNTR1 Input,  $\overline{INT1}$  Input Timing Diagram when  $V_{CC} = 3\text{ V}$** **Table 5.23 TCIN Input,  $\overline{INT3}$  Input**

Symbol	Parameter	Standard		Unit
		Min.	Max.	
$t_{c(TCIN)}$	TCIN input cycle time	1,200 <sup>(1)</sup>	–	ns
$t_{WH(TCIN)}$	TCIN input "H" width	600 <sup>(2)</sup>	–	ns
$t_{WL(TCIN)}$	TCIN input "L" width	600 <sup>(2)</sup>	–	ns

**NOTES:**

1. When using the timer C input capture mode, adjust the cycle time to (1/timer C count source frequency  $\times$  3) or above.
2. When using the timer C input capture mode, adjust the width to (1/timer C count source frequency  $\times$  1.5) or above.

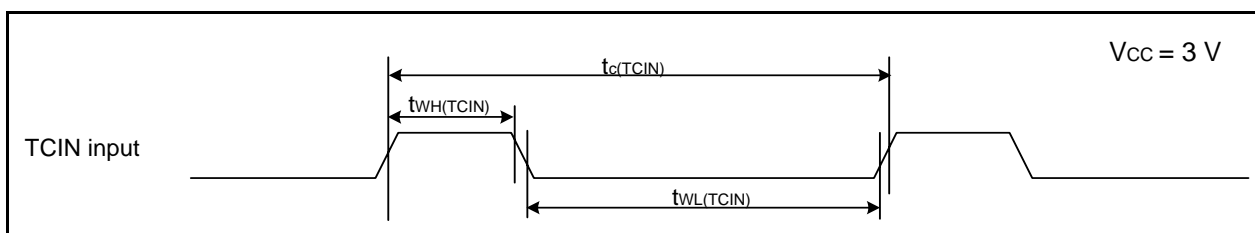
**Figure 5.11 TCIN Input,  $\overline{INT3}$  Input Timing Diagram when  $V_{CC} = 3\text{ V}$**

**Table 5.24 Serial Interface**

Symbol	Parameter	Standard		Unit
		Min.	Max.	
$t_{c(CK)}$	CLKi input cycle time	300	–	ns
$t_{w(CKH)}$	CLKi input “H” width	150	–	ns
$t_{w(CKL)}$	CLKi input “L” width	150	–	ns
$t_{d(C-Q)}$	TXDi output delay time	–	80	ns
$t_{h(C-Q)}$	TXDi hold time	0	–	ns
$t_{su(D-C)}$	RXDi input setup time	70	–	ns
$t_{h(C-D)}$	RXDi input hold time	90	–	ns

i = 0 or 1

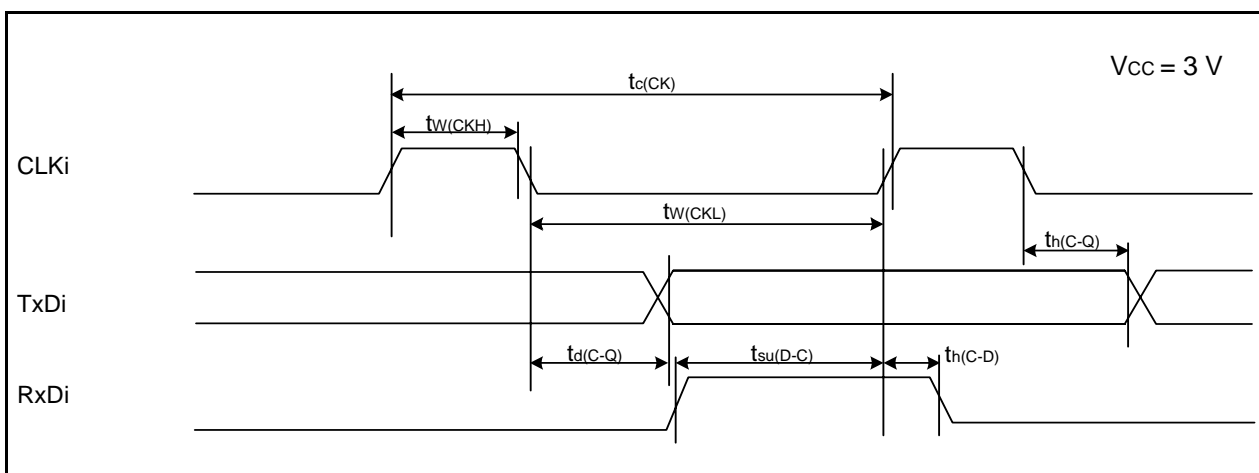

**Figure 5.12 Serial Interface Timing Diagram when Vcc = 3 V**

**Table 5.25 External Interrupt  $\overline{INT0}$  Input**

Symbol	Parameter	Standard		Unit
		Min.	Max.	
$t_{w(INH)}$	$\overline{INT0}$ input “H” width	380 <sup>(1)</sup>	–	ns
$t_{w(INL)}$	$\overline{INT0}$ input “L” width	380 <sup>(2)</sup>	–	ns

NOTES:

1. When selecting the digital filter by the  $\overline{INT0}$  input filter select bit, use an  $\overline{INT0}$  input HIGH width of either (1/digital filter clock frequency x 3) or the minimum value of standard, whichever is greater.
2. When selecting the digital filter by the  $\overline{INT0}$  input filter select bit, use an  $\overline{INT0}$  input LOW width of either (1/digital filter clock frequency x 3) or the minimum value of standard, whichever is greater.

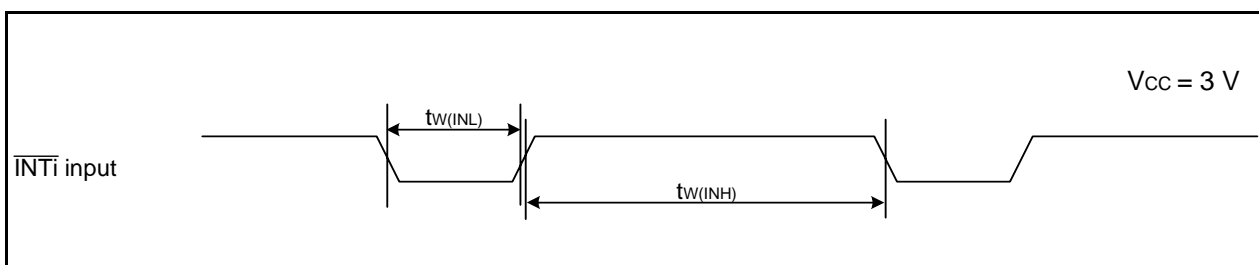

**Figure 5.13 External Interrupt  $\overline{INT0}$  Input Timing Diagram when Vcc = 3 V**

# Package Dimensions

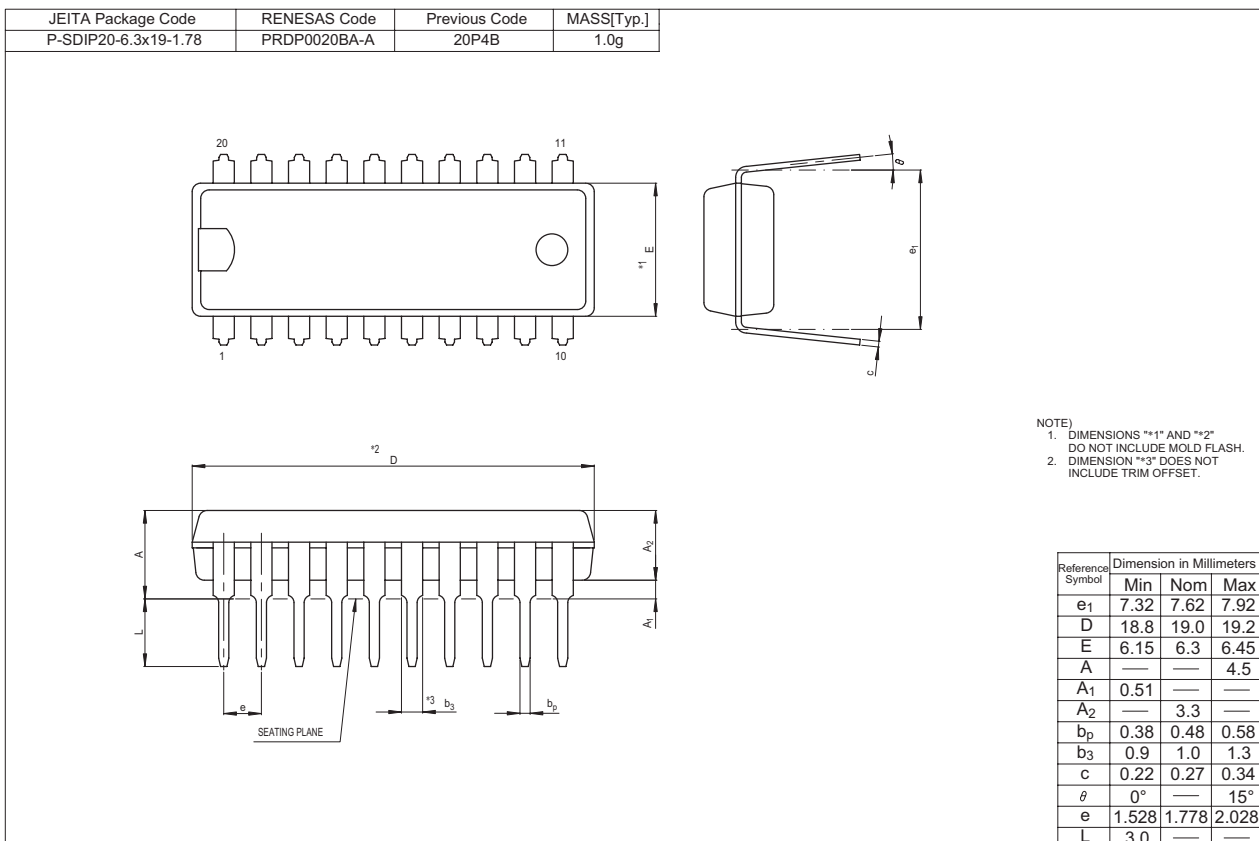
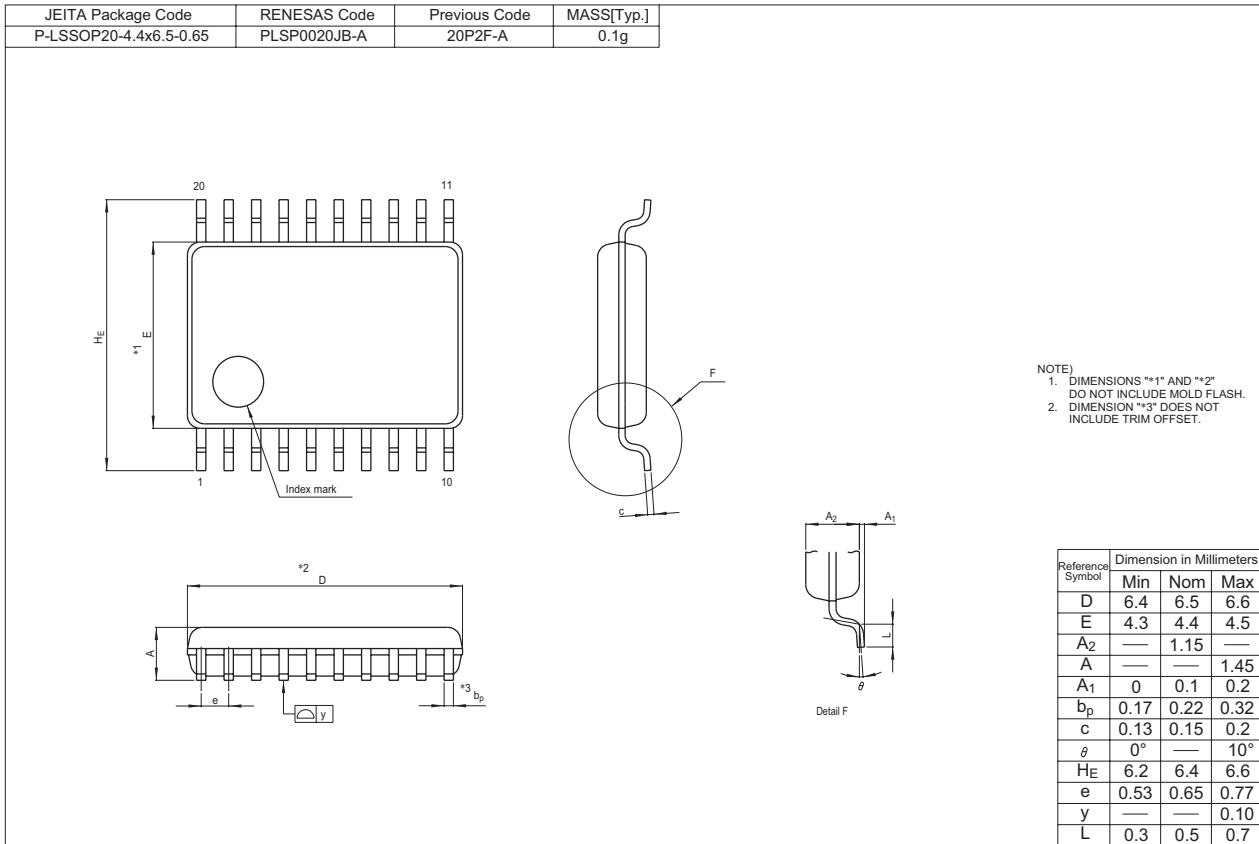

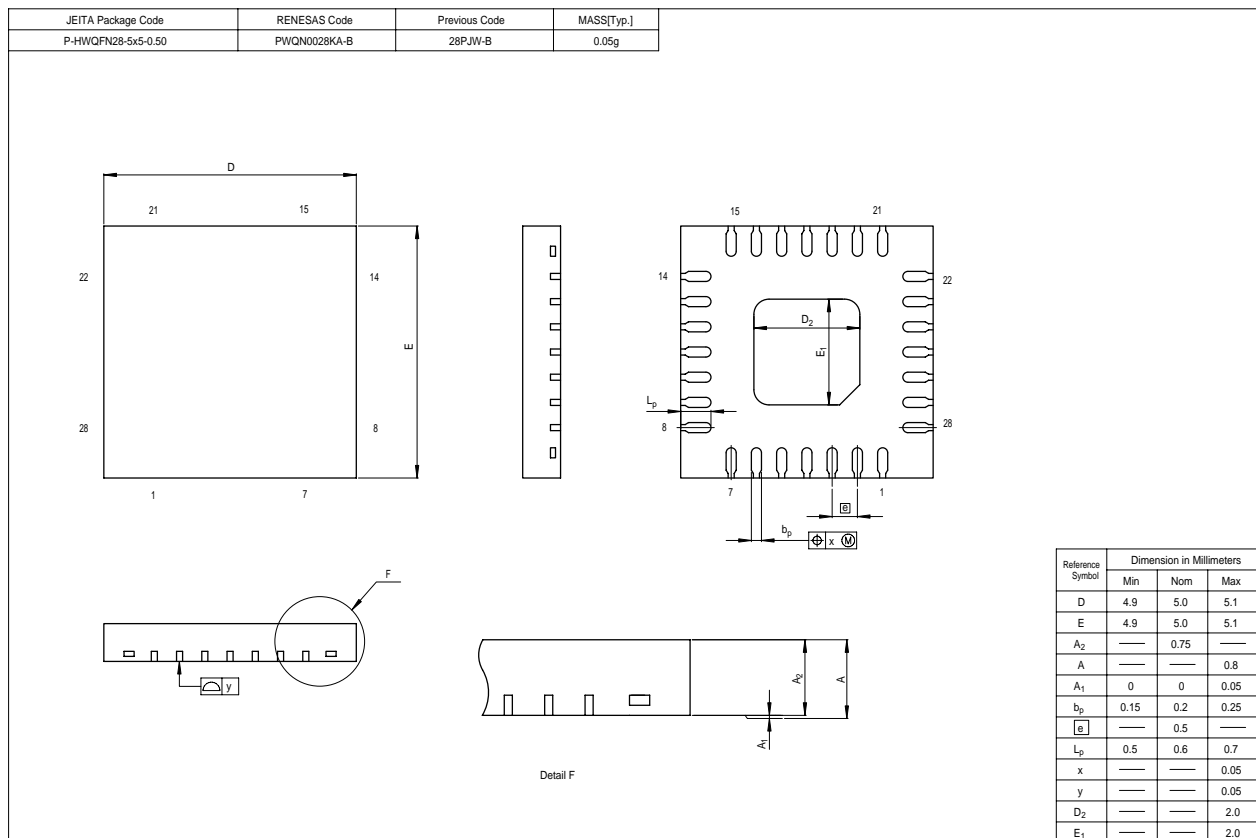



REVISION HISTORY

R8C/18 Group, R8C/19 Group Datasheet

Rev.	Date	Description	
		Page	Summary
0.10	Nov 15, 2004	–	First Edition issued
0.20	Jan 11, 2005	5, 6	Tables 1.3 and 1.4: The date updated
0.21	Apr 04, 2005	2, 3 4 5, 6 5, 6 7, 8 10 16 17 18 20	Tables 1.1 and 1.2: Partly revised Figure 1.1: Partly revised Tables 1.3 and 1.4: Partly revised Figure 1.2 and 1.3: Partly revised Figure 1.4 and 1.5: Partly revised Table 1.6: Partly revised Table 4.1: Partly revised Table 4.2: Partly revised Table 4.3: Partly revised Package Dimensions are revised
1.00	May 27, 2005	5, 6 9 25 26 28 32	Tables 1.3 and 1.4: Partly revised Table 1.5: Partly revised Table 5.9: Revised Table 5.10: Partly revised Table 5.13: Partly revised Table 5.20: Partly revised
1.10	Jun 09, 2005	26	Table 5.10: Partly revised
1.20	Nov 01, 2005	3 4 6 9 11 13 15	Table 1.2 Performance Outline of the R8C/19 Group; Flash Memory: (Data area) → (Data flash) (Program area) → (Program ROM) revised Figure 1.1 Block Diagram; “Peripheral Function” added, “System Clock Generation” → “System Clock Generator” revised Table 1.4 Product Information of R8C/19 Group; ROM capacity: “Program area” → “Program ROM”, “Data area” → “Data flash” revised Table 1.5 Pin Description; Power Supply Input: “VCC/AVCC” → “VCC”, “VSS/AVSS” → “VSS” revised Analog Power Supply Input: added Figure 2.1 CPU Register; “Reserved Area” → “Reserved Bit” revised 2.8.10 Reserved Area; “Reserved Area” → “Reserved Bit” revised 3.2 R8C/19 Group, Figure 3.2 Memory Map of R8C/19 Group; “Data area” → “Data flash”, “Program area” → “Program ROM” revised

REVISION HISTORY

R8C/18 Group, R8C/19 Group Datasheet

Rev.	Date	Description	
		Page	Summary
1.20	Nov 01, 2005	16	Table 4.1 SFR Information(1); 0009h: "XXXXXX00b" → "00h" 000Ah: "00XXX000b" → "00h" 001Eh: "XXXXX000b" → "00h" revised
		18	Table 4.3 SFR Information(3); 0085h: "Prescaler Z" → "Prescaler Z Register" 0086h: "Timer Z Secondary" → "Timer Z Secondary Register" 0087h: "Timer Z Primary" → "Timer Z Primary Register" 008Ch: "Prescaler X" → "Prescaler X Register" 008Dh: "Timer X" → "Timer X Register" 0090h, 0091h: "Timer C" → "Timer C Register" revised
		22	Table 5.4 Flash Memory (Program ROM) Electrical Characteristics; NOTES 3 and 5 revised, NOTE8 deleted
		23	Table 5.5 Flash Memory (Data flash Block A, Block B) Electrical Characteristics; NOTES 1 and 3 revised
		25	Table 5.8 Reset Circuit Electrical Characteristics (When Using Voltage Monitor 1 Reset); NOTE 2 revised
		26	Table 5.10 High-speed On-Chip Oscillator Circuit Electrical Characteristics; "High-Speed On-Chip Oscillator ..." → "High-Speed On-Chip Oscillator Frequency ..." revised NOTE 2, 3 added
		28	Table 5.13 Electrical Characteristics (2) [Vcc = 5V]; NOTE 1 deleted
		32	Table 5.20 Electrical Characteristics (4) [Vcc = 3V]; NOTE 1 deleted
		1.30	Dec 16, 2005
5, 6	Table 1.3, Table 1.4 revised		
24	Table 5.4 Flash Memory (Program ROM) Electrical Characteristics; Ta → Ambient temperature		
25	Table 5.5 Flash Memory (Data flash Block A, Block B) Electrical Characteristics; Ta → Ambient temperature		
30, 34	Table 5.13, Table 5.20; The title revised, Condition of Stop Mode added		
32, 36 37, 38	Table 5.17, Table 5.24; td(C-Q) and tsu(D-C) revised Package Dimensions revised		
1.40	Apr 14, 2006	2, 3	Table 1.1, Table 1.2; Interrupts: Internal 8 → 10 sources,
		5, 6	Table 1.3, Table 1.4; Type No. added, deleted
		16, 17	Figure 3.1, Figure 3.2; Part Number added, deleted
		24, 25	Table 5.4, Table 5.5; Conditions: VCC = 5.0 V at Topr = 25 °C deleted

**Keep safety first in your circuit designs!**

1. Renesas Technology Corp. puts the maximum effort into making semiconductor products better and more reliable, but there is always the possibility that trouble may occur with them. Trouble with semiconductors may lead to personal injury, fire or property damage.  
Remember to give due consideration to safety when making your circuit designs, with appropriate measures such as (i) placement of substitutive, auxiliary circuits, (ii) use of nonflammable material or (iii) prevention against any malfunction or mishap.

**Notes regarding these materials**

1. These materials are intended as a reference to assist our customers in the selection of the Renesas Technology Corp. product best suited to the customer's application; they do not convey any license under any intellectual property rights, or any other rights, belonging to Renesas Technology Corp. or a third party.
  2. Renesas Technology Corp. assumes no responsibility for any damage, or infringement of any third-party's rights, originating in the use of any product data, diagrams, charts, programs, algorithms, or circuit application examples contained in these materials.
  3. All information contained in these materials, including product data, diagrams, charts, programs and algorithms represents information on products at the time of publication of these materials, and are subject to change by Renesas Technology Corp. without notice due to product improvements or other reasons. It is therefore recommended that customers contact Renesas Technology Corp. or an authorized Renesas Technology Corp. product distributor for the latest product information before purchasing a product listed herein.  
The information described here may contain technical inaccuracies or typographical errors.  
Renesas Technology Corp. assumes no responsibility for any damage, liability, or other loss rising from these inaccuracies or errors.  
Please also pay attention to information published by Renesas Technology Corp. by various means, including the Renesas Technology Corp. Semiconductor home page (<http://www.renesas.com>).
  4. When using any or all of the information contained in these materials, including product data, diagrams, charts, programs, and algorithms, please be sure to evaluate all information as a total system before making a final decision on the applicability of the information and products. Renesas Technology Corp. assumes no responsibility for any damage, liability or other loss resulting from the information contained herein.
  5. Renesas Technology Corp. semiconductors are not designed or manufactured for use in a device or system that is used under circumstances in which human life is potentially at stake. Please contact Renesas Technology Corp. or an authorized Renesas Technology Corp. product distributor when considering the use of a product contained herein for any specific purposes, such as apparatus or systems for transportation, vehicular, medical, aerospace, nuclear, or undersea repeater use.
  6. The prior written approval of Renesas Technology Corp. is necessary to reprint or reproduce in whole or in part these materials.
  7. If these products or technologies are subject to the Japanese export control restrictions, they must be exported under a license from the Japanese government and cannot be imported into a country other than the approved destination.  
Any diversion or reexport contrary to the export control laws and regulations of Japan and/or the country of destination is prohibited.
  8. Please contact Renesas Technology Corp. for further details on these materials or the products contained therein.
- 



**RENESAS SALES OFFICES**

<http://www.renesas.com>

Refer to "<http://www.renesas.com/en/network>" for the latest and detailed information.

**Renesas Technology America, Inc.**

450 Holger Way, San Jose, CA 95134-1368, U.S.A  
Tel: <1> (408) 382-7500, Fax: <1> (408) 382-7501

**Renesas Technology Europe Limited**

Dukes Meadow, Millboard Road, Bourne End, Buckinghamshire, SL8 5FH, U.K.  
Tel: <44> (1628) 585-100, Fax: <44> (1628) 585-900

**Renesas Technology (Shanghai) Co., Ltd.**

Unit 204, 205, AZIAcenter, No.1233 Lujiazui Ring Rd, Pudong District, Shanghai, China 200120  
Tel: <86> (21) 5877-1818, Fax: <86> (21) 6887-7898

**Renesas Technology Hong Kong Ltd.**

7th Floor, North Tower, World Finance Centre, Harbour City, 1 Canton Road, Tsimshatsui, Kowloon, Hong Kong  
Tel: <852> 2265-6688, Fax: <852> 2730-6071

**Renesas Technology Taiwan Co., Ltd.**

10th Floor, No.99, Fushing North Road, Taipei, Taiwan  
Tel: <886> (2) 2715-2888, Fax: <886> (2) 2713-2999

**Renesas Technology Singapore Pte. Ltd.**

1 Harbour Front Avenue, #06-10, Keppel Bay Tower, Singapore 098632  
Tel: <65> 6213-0200, Fax: <65> 6278-8001

**Renesas Technology Korea Co., Ltd.**

Kukje Center Bldg. 18th Fl., 191, 2-ka, Hangang-ro, Yongsan-ku, Seoul 140-702, Korea  
Tel: <82> (2) 796-3115, Fax: <82> (2) 796-2145

**Renesas Technology Malaysia Sdn. Bhd**

Unit 906, Block B, Menara Amcorp, Amcorp Trade Centre, No.18, Jalan Persiaran Barat, 46050 Petaling Jaya, Selangor Darul Ehsan, Malaysia  
Tel: <603> 7955-9390, Fax: <603> 7955-9510

# Mouser Electronics

Authorized Distributor

Click to View Pricing, Inventory, Delivery & Lifecycle Information:

## Renesas Electronics:

[R5F21181SP#U0](#) [R5F21181DSP#U0](#) [R5F21184SP#U0](#) [R5F21182DSP#U0](#) [R5F21192DSP#U0](#) [R5F21193DSP#U0](#)  
[R5F21194NP#U0](#) [R5F21182NP#U0](#) [R5F21194DSP#U0](#) [R5F21183SP#U0](#) [R5F21184NP#U0](#) [R5F21191SP#U0](#)  
[R5F21193SP#U0](#) [R5F21183DSP#U0](#) [R5F21184DSP#U0](#) [R5F21191DSP#U0](#) [R5F21192SP#U0](#) [R5F21192SP#W4](#)  
[R5F21194SP#U0](#) [R5F21182SP#U0](#)

Компания «Океан Электроники» предлагает заключение долгосрочных отношений при поставках импортных электронных компонентов на взаимовыгодных условиях!

Наши преимущества:

- Поставка оригинальных импортных электронных компонентов напрямую с производств Америки, Европы и Азии, а так же с крупнейших складов мира;
- Широкая линейка поставок активных и пассивных импортных электронных компонентов (более 30 млн. наименований);
- Поставка сложных, дефицитных, либо снятых с производства позиций;
- Оперативные сроки поставки под заказ (от 5 рабочих дней);
- Экспресс доставка в любую точку России;
- Помощь Конструкторского Отдела и консультации квалифицированных инженеров;
- Техническая поддержка проекта, помощь в подборе аналогов, поставка прототипов;
- Поставка электронных компонентов под контролем ВП;
- Система менеджмента качества сертифицирована по Международному стандарту ISO 9001;
- При необходимости вся продукция военного и аэрокосмического назначения проходит испытания и сертификацию в лаборатории (по согласованию с заказчиком);
- Поставка специализированных компонентов военного и аэрокосмического уровня качества (Xilinx, Altera, Analog Devices, Intersil, Interpoint, Microsemi, Actel, Aeroflex, Peregrine, VPT, Syfer, Eurofarad, Texas Instruments, MS Kennedy, Miteq, Cobham, E2V, MA-COM, Hittite, Mini-Circuits, General Dynamics и др.);

Компания «Океан Электроники» является официальным дистрибьютором и эксклюзивным представителем в России одного из крупнейших производителей разъемов военного и аэрокосмического назначения «**JONHON**», а так же официальным дистрибьютором и эксклюзивным представителем в России производителя высокотехнологичных и надежных решений для передачи СВЧ сигналов «**FORSTAR**».



## JONHON

«**JONHON**» (основан в 1970 г.)

Разъемы специального, военного и аэрокосмического назначения:

(Применяются в военной, авиационной, аэрокосмической, морской, железнодорожной, горно- и нефтедобывающей отраслях промышленности)

«**FORSTAR**» (основан в 1998 г.)

ВЧ соединители, коаксиальные кабели,  
кабельные сборки и микроволновые компоненты:

(Применяются в телекоммуникациях гражданского и специального назначения, в средствах связи, РЛС, а так же военной, авиационной и аэрокосмической отраслях промышленности).



Телефон: 8 (812) 309-75-97 (многоканальный)

Факс: 8 (812) 320-03-32

Электронная почта: [ocean@oceanchips.ru](mailto:ocean@oceanchips.ru)

Web: <http://oceanchips.ru/>

Адрес: 198099, г. Санкт-Петербург, ул. Калинина, д. 2, корп. 4, лит. А