

HV9910B PFC 40W LED Driver Demoboard

General Description

The Supertex HV9910BDB7 demonstrates the use of an HV9910B control IC in an off-line, High Brightness LED driver application. The board incorporates power factor correction (PFC) and satisfies the limits for harmonic currents according to the EN61000-3-2 Class C standard having total harmonic distortion (THD) less than 20%. The board features a low component count and long life operation due to the absence of electrolytic capacitors. The board is designed to supply a string of LEDs with a current of 350mA and a voltage in the 65 to 105V range from a 220/230VAC line.

The conversion stage draws line current throughout the AC line cycle, partly using a charge pumping and partly using a boost conversion technique to charge the bulk energy storage capacitors. The LED current is provided with a continuous mode buck stage giving a DC current with about 30% peak-to-peak ripple. A patent for this conversion technique is pending. Please inquire with the Supertex applications department for design guidance, should change of input line voltage, output voltage, or output current be desired.

An effort was made to satisfy the requirements of CISPR 15 (EN55015), limits and methods of measurement of radio disturbance characteristics of electrical lighting and similar equipment.

The connection diagram details the hookup of the board to the AC line. Note that the load is **NOT** galvanically isolated, and that measurements to the board require measurement techniques in common use with non-isolated off-line power supplies (isolation transformers, differential probes, etc).

Board Layout

Top View

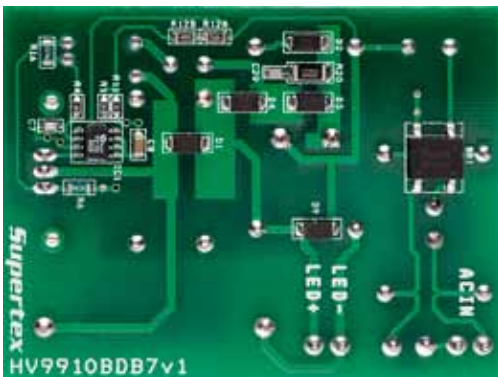

Bottom View



Actual Size: 3.0" x 2.3" x 1.1"

Specifications

Parameter	Value
Input voltage	190~265VAC, 50Hz
Power factor	0.95
Total harmonic distortion	<20%; EN 61000-3-2 Class C
EMI limits	CISPR 15
Output voltage	65~105V
Output current	350mA±10%
Output power	40W
Efficiency	90%
Load regulation	<3%
AC Line regulation	<1.5%
Output ripple	<30% peak-peak
Life time	Non-Electrolytic
Output short circuit protection	No
Output open circuit protection	Yes
Dimensions	3.0" x 2.3" x 1.1" (76mm x 58mm x 28mm)

Connection Diagram

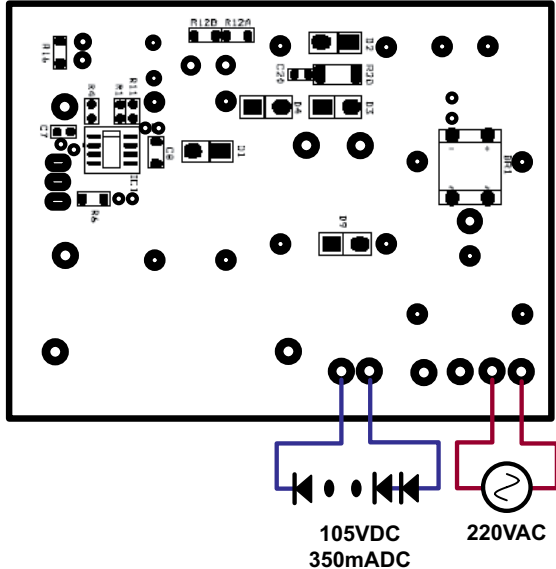

Connections

Input Voltage - Connect the AC line input voltage to AC VIN as shown.

LED String - Connect the LED strings between LED+ and LED- as shown (anode of the string to LED+ and cathode to LED-).

Schematic Diagram

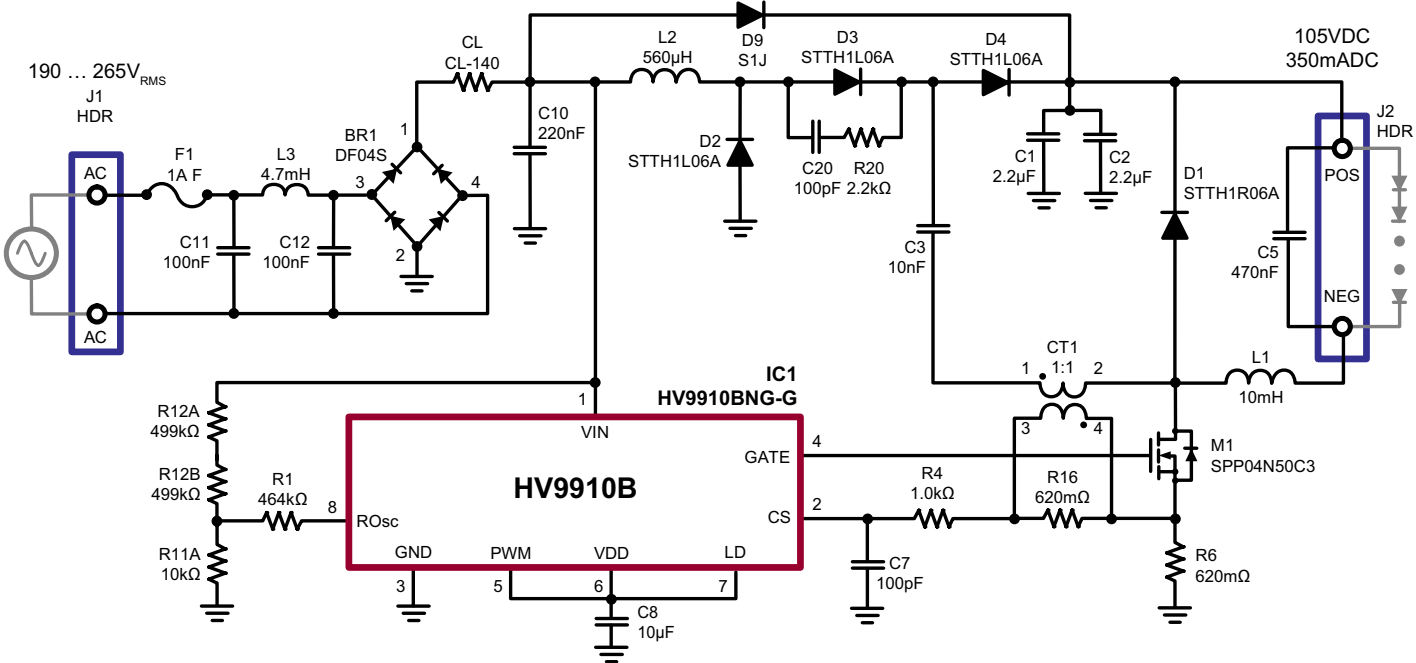

Typical Characteristics

Figure 1. Efficiency at full load.

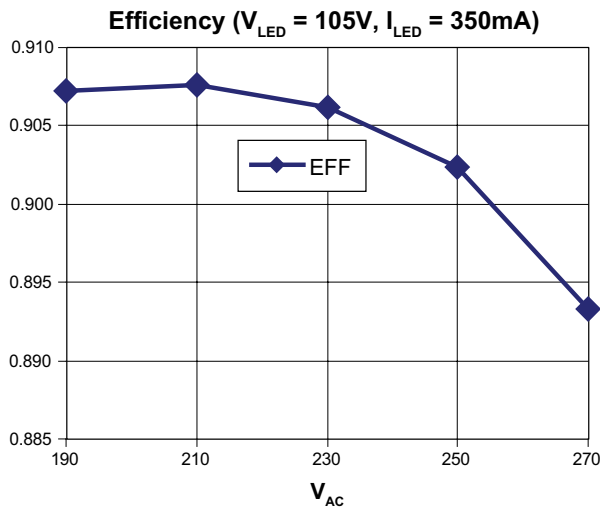

Figure 2. Efficiency at nominal AC line voltage.

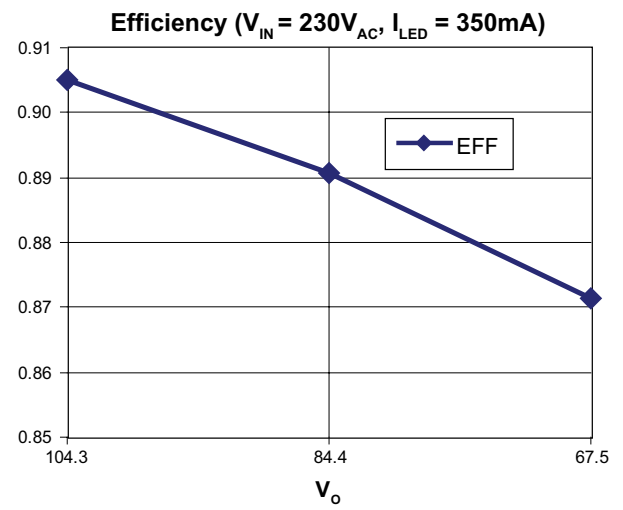

Figure 3. Load regulation.

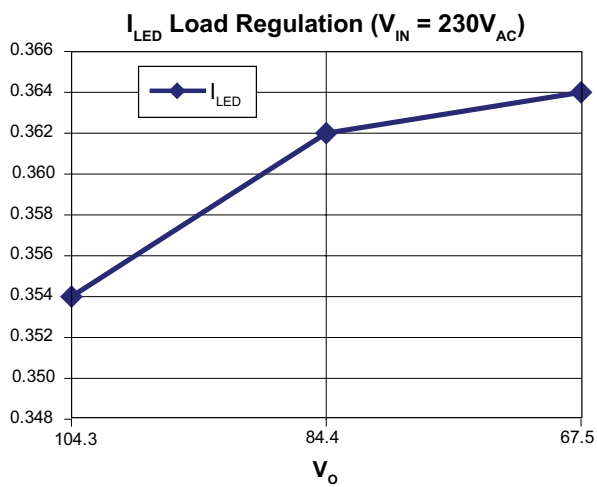

Figure 4. AC line regulation.

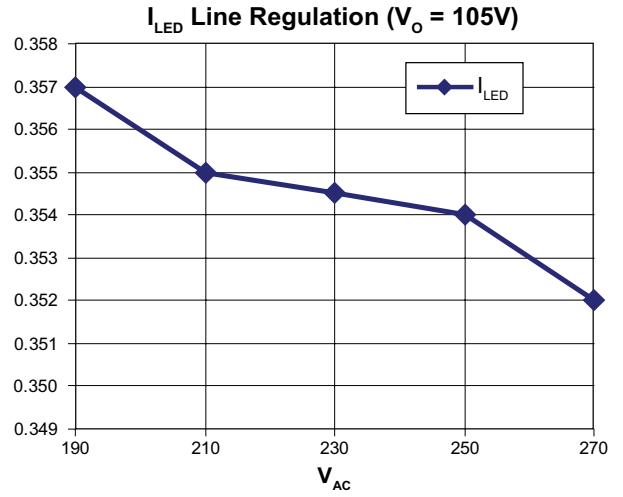

Figure 5. Harmonic Distortion vs. AC Line Voltage.

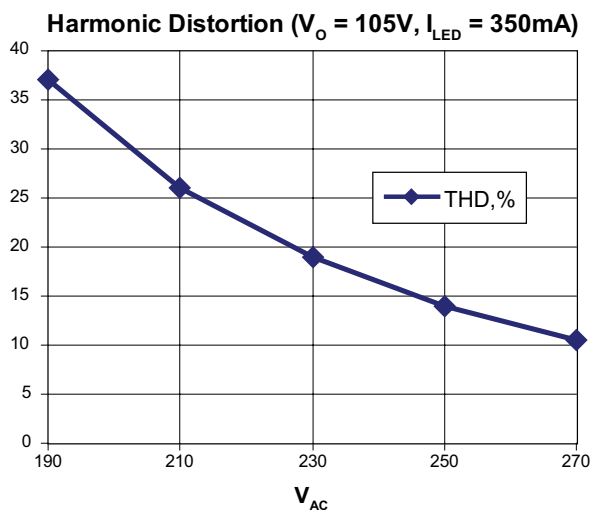

Figure 6. Power Factor vs. AC Line Voltage.

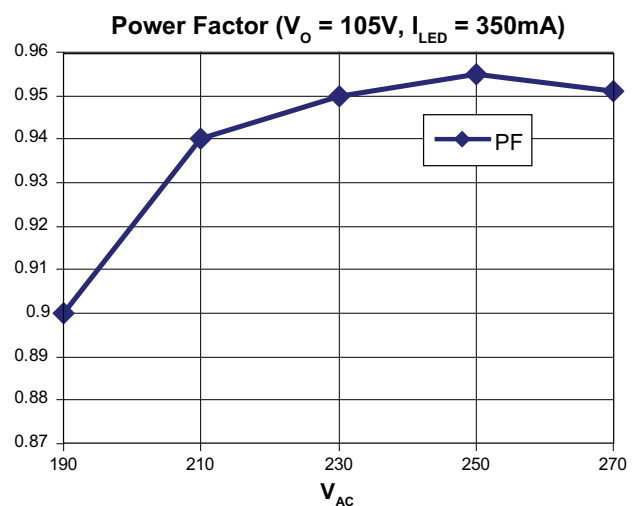

Figure 7. EMI Characterization - Conducted Emissions vs CISPR 15 Limits.

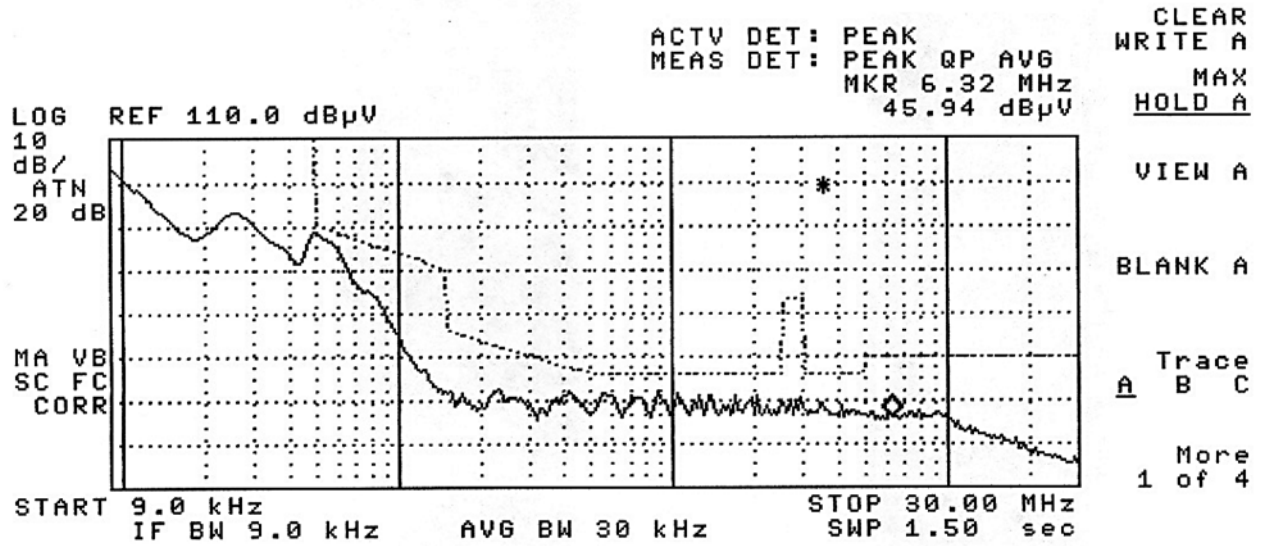
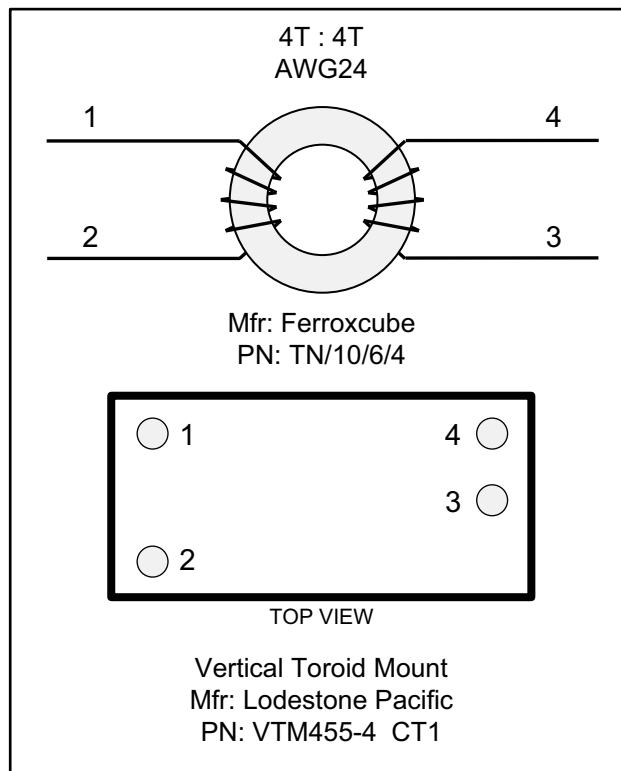

Figure 8. CT1 Construction Diagram.



Bill of Materials

Qty	Ref Des	Description	Manufacturer	Part Number
1	BR1	Rect Bridge, DFS, 400V, 1.5A	Fairchild Semi	DF04S
2	C1, C2	Cap, MZPEF, 450VDC, 10%, 2.2UF	Panasonic ECG	ECQ-E2W225KH
1	C3	Cap, MZPEF, 630VDC, 5%, 10NF	EPCOS Inc	B32529C8103J
1	C5	Cap, MZPEF, 400V, 10%, .47UF	EPCOS Inc	B32522C6474K
1	C7	Cap, CER, NP0, 50V, 10%, 0805, 100PF	Kemet	C0805C101K5GACTU
1	C8	Cap, CER, X7R, 10V, 10%, 1206, 10UF	Murata	GRM31CR71A106KA01L
1	C20	Cap, CER, NP0, 1000V, 5%, 0805, 100PF	Vishay/Vitramon	VJ0805A101JXGAT5Z
1	C10	Cap, MKP, 220NF, 305VAC, X2, 125C, 20%	EPCOS Inc	B32922T2224M
2	C11, C12	Cap, MKP, 100NF, 305VAC, X2, 125C, 20%	EPCOS Inc	B32922A2104M
1	CL1	Inrush current limiter, 50/0.89Ω, 1.1A	GE Sensing	CL-140
1	CT1	Core, toroidal, TN10/6/4-3E25	Yageo / Ferroxcube	TN10/6/4-3E25
1		Toroidal core mount, 0.455Dia, 4PIN	Lodestone Pacific	VTM455-4T
AR		Magnet wire, MW28C, SPN AWG24	MWS Wire Industries	SPN AWG24
1	D1	Diode, ultrafast, 600V, 1A, SMA	STMicroelectronics	STTH1R06A
3	D2, D3, D4	Diode fast, 600V, 1A, SMA	STMicroelectronics	STTH1L06A
1	D9	Rectifier, GPP, 600V, 1A, SMA	Diodes Inc	S1J-13-F
1	F1	Fuse fast, 1.00A, IEC, Short, TR5	Wickmann USA	37011000410
1	HS1	Heatsink, TO-220, Ver MNT W/Tab, H75 21K	Aavid Thermalloy	574502B03700G
1	IC1	IC, LED Driver, 8-Lead SOIC	Supertex	HV9910BLG-G
2	J1, J2	Header, 2POS, .156, VERT TIN	Molex	26-48-1021
1	L1	Choke AXL, 14mm, 10mH, 10%, 350mA	Renco	RL-1292-10000
1	L2	Choke SH RAD, 16mm, 10%, 560μH, 1.1A	Sumida	RCR1616NP-561K
1	L3	Choke SH RAD, 13mm, 15%, 4.7mH, 370mA	Sumida	RCP1317NP-472L
1	M1	MOSFET, N-CH, 560V, 4.5A, TO-220AB	Infineon Technologies	SPP04N50C3
1	R1	Resistor 1/8W, 1%, 0805, 464KΩ	Panasonic ECG	ERJ-6ENF4643V
1	R4	Resistor 1/8W, 1%, 0805, 1.00KΩ	Panasonic ECG	ERJ-6ENF1001V
1	R11	Resistor 1/8W, 1%, 0805, 10.0KΩ	Panasonic ECG	ERJ-6ENF1002V
2	R12A, R12B	Resistor 1/4W, 1%, 1206, 499KΩ	Panasonic ECG	ERJ-8ENF4993V
1	R20	Resistor 1/2W, 5%, 2010, 2.2KΩ	Panasonic ECG	ERJ-12ZYJ222U
2	R6, R16	Resistor 1/2W, 1%, 1206, .62Ω	Susumu Co Ltd	RL1632R-R620-F

Supertex inc. does not recommend the use of its products in life support applications, and will not knowingly sell them for use in such applications unless it receives an adequate "product liability indemnification insurance agreement." **Supertex inc.** does not assume responsibility for use of devices described, and limits its liability to the replacement of the devices determined defective due to workmanship. No responsibility is assumed for possible omissions and inaccuracies. Circuitry and specifications are subject to change without notice. For the latest product specifications refer to the **Supertex inc.** (website: <http://www.supertex.com>)

Компания «Океан Электроники» предлагает заключение долгосрочных отношений при поставках импортных электронных компонентов на взаимовыгодных условиях!

Наши преимущества:

- Поставка оригинальных импортных электронных компонентов напрямую с производств Америки, Европы и Азии, а так же с крупнейших складов мира;
- Широкая линейка поставок активных и пассивных импортных электронных компонентов (более 30 млн. наименований);
- Поставка сложных, дефицитных, либо снятых с производства позиций;
- Оперативные сроки поставки под заказ (от 5 рабочих дней);
- Экспресс доставка в любую точку России;
- Помощь Конструкторского Отдела и консультации квалифицированных инженеров;
- Техническая поддержка проекта, помощь в подборе аналогов, поставка прототипов;
- Поставка электронных компонентов под контролем ВП;
- Система менеджмента качества сертифицирована по Международному стандарту ISO 9001;
- При необходимости вся продукция военного и аэрокосмического назначения проходит испытания и сертификацию в лаборатории (по согласованию с заказчиком);
- Поставка специализированных компонентов военного и аэрокосмического уровня качества (Xilinx, Altera, Analog Devices, Intersil, Interpoint, Microsemi, Actel, Aeroflex, Peregrine, VPT, Syfer, Eurofarad, Texas Instruments, MS Kennedy, Miteq, Cobham, E2V, MA-COM, Hittite, Mini-Circuits, General Dynamics и др.);

Компания «Океан Электроники» является официальным дистрибьютором и эксклюзивным представителем в России одного из крупнейших производителей разъемов военного и аэрокосмического назначения «JONHON», а так же официальным дистрибьютором и эксклюзивным представителем в России производителя высокотехнологичных и надежных решений для передачи СВЧ сигналов «FORSTAR».



JONHON

«JONHON» (основан в 1970 г.)

Разъемы специального, военного и аэрокосмического назначения:

(Применяются в военной, авиационной, аэрокосмической, морской, железнодорожной, горно- и нефтедобывающей отраслях промышленности)

«FORSTAR» (основан в 1998 г.)

ВЧ соединители, коаксиальные кабели,
кабельные сборки и микроволновые компоненты:

(Применяются в телекоммуникациях гражданского и специального назначения, в средствах связи, РЛС, а так же военной, авиационной и аэрокосмической отраслях промышленности).



Телефон: 8 (812) 309-75-97 (многоканальный)

Факс: 8 (812) 320-03-32

Электронная почта: ocean@oceanchips.ru

Web: <http://oceanchips.ru/>

Адрес: 198099, г. Санкт-Петербург, ул. Калинина, д. 2, корп. 4, лит. А