



**TISP8200HDM BUFFERED P-GATE SCR DUAL  
TISP8201HDM BUFFERED N-GATE SCR DUAL**

**COMPLEMENTARY BUFFERED-GATE SCRS  
FOR DUAL POLARITY SLIC OVERVOLTAGE PROTECTION**

**TISP820xHDM Overvoltage Protectors**

High Performance Protection for SLICs with +ve & -ve Battery Supplies

**TISP8200HDM Negative Overvoltage Protector**  
 – Wide -20 to -110 V Programming Range  
 – Low +15 mA Max. Gate Triggering Current  
 – High -150 mA Min. Holding Current

**TISP8201HDM Positive Overvoltage Protector**  
 – Wide +20 to +110 V Programming Range  
 – Low -15 mA Max. Gate Triggering Current  
 – +20 mA Min. Holding Current

Rated for International Surge Wave Shapes

Wave Shape	Standard	I <sub>PPSM</sub> A
2/10	GR-1089-CORE	500
10/700	ITU-T K.20/21/45	150
10/1000	GR-1089-CORE	100

 .....UL Recognized Component

**Circuit Application Diagram**

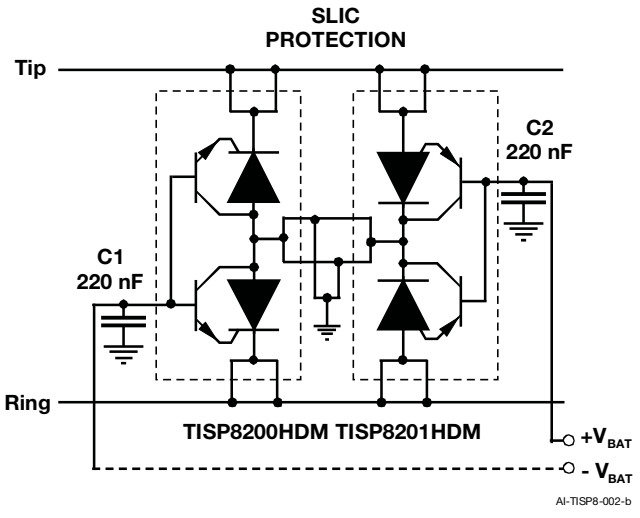

**TISP8200HDM 8-SOIC (210 mil) Package (Top View)**

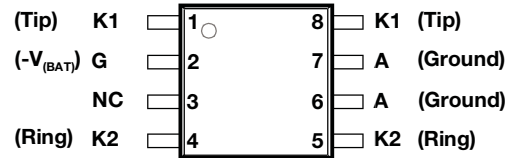

NC - No internal connection  
 Terminal typical application names shown in parenthesis  
 MD-8SOIC(210)-007-a

**TISP8200HDM Device Symbol**

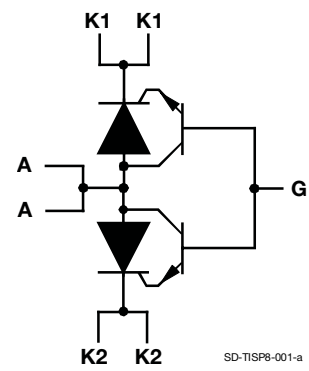

**TISP8201HDM 8-SOIC (210 mil) Package (Top View)**

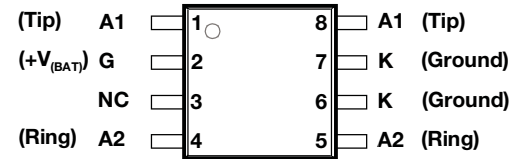

NC - No internal connection  
 Terminal typical application names shown in parenthesis  
 MD-8SOIC(210)-008-a

**TISP8201HDM Device Symbol**

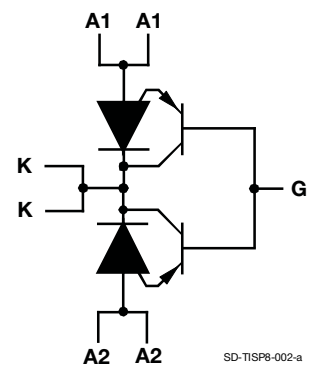

\*RoHS Directive 2002/95/EC Jan 27 2003 including Annex  
 OCTOBER 2005 — REVISED MAY 2007  
 Specifications are subject to change without notice.  
 Customers should verify actual device performance in their specific applications.

# TISP820xHDM Overvoltage Protectors

**BOURNS®**

## Description

The TISP8200HDM/TISP8201HDM combination has been designed to protect dual polarity supply rail monolithic SLICs (Subscriber Line Interface Circuits) against overvoltages on the telephone line caused by lightning, a.c. power contact and induction. Protection against negative overvoltages is given by the TISP8200HDM. Protection against positive overvoltages is given by the TISP8201HDM. Both parts are in 8-SOIC (210 mil) surface mount packages.

The TISP8200HDM has an array of two buffered P-gate SCRs with a common anode connection. Each SCR cathode and gate has a separate terminal connection. The NPN buffer transistors reduce the gate supply current. In use, the cathodes of the TISP8200HDM SCRs are connected to the two conductors of the POTS line. The gates are connected to the appropriate negative voltage battery feed of the SLIC driving the line conductor pair, so that the TISP8200HDM protection voltage tracks the SLIC negative supply voltage. The anode of the TISP8200HDM is connected to the SLIC common. Negative overvoltages are initially clipped close to the SLIC negative supply by emitter follower action of the NPN buffer transistor. If sufficient clipping current flows, the SCR will regenerate and switch into a low voltage on-state condition. As the overvoltage subsides the high holding current of the SCR helps prevent d.c. latchup.

The TISP8201HDM has an array of two buffered N-gate SCRs with a common cathode connection. Each SCR anode and gate has a separate terminal connection. The PNP buffer transistors reduce the gate supply current. In use, the anodes of the TISP8201HDM SCRs are connected to the two conductors of the POTS line. The gates are connected to the appropriate positive voltage battery feed of the SLIC driving that line pair, so that the TISP8201HDM protection voltage tracks the SLIC positive supply voltage. The cathode of the TISP8201HDM is connected to the SLIC common. Positive overvoltages are initially clipped close to the SLIC positive supply by emitter follower action of the PNP buffer transistor. If sufficient clipping current flows the SCR will regenerate and switch into a low voltage on-state condition. As the overvoltage subsides the SLIC pulls the conductor voltage down to its normal negative value and this commutates the conducting SCR into a reverse biased condition.

## How to Order

Device	Package	Carrier	Order As	Marking Code	Standard Quantity
TISP8200HDM	8-SOIC (210 mil)	Embossed Tape Reeled	TISP8200HDMR-S	8200H	2000
TISP8201HDM			TISP8201HDMR-S	8201H	

## TISP8200HDM Absolute Maximum Ratings, $T_A = 25^\circ\text{C}$ (Unless Otherwise Noted)

Rating	Symbol	Value	Unit
Repetitive peak off-state voltage, $V_{GK} = 0$	$V_{DRM}$	-120	V
Repetitive peak reverse voltage, $V_{GA} = -70\text{ V}$	$V_{RRM}$	120	
Non-repetitive peak impulse current (see Notes 1, 2 and 3) 2/10 $\mu\text{s}$ (Telcordia GR-1089-CORE, 2/10 $\mu\text{s}$ voltage wave shape) 5/310 $\mu\text{s}$ (ITU-T K.44, 10/700 $\mu\text{s}$ voltage wave shape used in K.20/21/45) 10/1000 $\mu\text{s}$ (Telcordia GR-1089-CORE, 10/1000 $\mu\text{s}$ voltage wave shape)	$I_{PPSM}$	-500 -150 -100	A
Non-repetitive peak on-state current, 50/60 Hz (see Notes 1, 2, 3 and 4) 10 ms 1 s 7 s 900 s	$I_{TSM}$	60 14 7 3.5	A
Junction temperature	$T_J$	-55 to +150	$^\circ\text{C}$
Storage temperature range	$T_{stg}$	-65 to +150	$^\circ\text{C}$

- NOTES: 1. Initially the device must be in thermal equilibrium with  $T_J = 25^\circ\text{C}$ . The surge may be repeated after the device returns to its initial conditions.
2. These non-repetitive rated currents are peak values. The rated current values may be applied to any cathode-anode terminal pair.
3. Rated currents only apply if pins 1 & 8 (K1, Tip) are connected together, pins 4 & 5 (K2, Ring) are connected together and pins 6 & 7 (A, Ground) are connected together.
4. These non-repetitive rated terminal currents are for the TISP8200HDM and TISP8201HDM together. Device (A)-terminal positive current values are conducted by the TISP8201HDM and (K)-terminal negative current values by the TISP8200HDM.

# TISP820xHDM Overvoltage Protectors

**BOURNS®**

## TISP8201HDM Absolute Maximum Ratings, $T_A = 25\text{ }^\circ\text{C}$ (Unless Otherwise Noted)

Rating	Symbol	Value	Unit
Repetitive peak off-state voltage, $V_{GA} = 0$	$V_{DRM}$	120	V
Repetitive peak reverse voltage, $V_{GK} = 70\text{ V}$	$V_{RRM}$	-120	
Non-repetitive peak impulse current (see Notes 5, 6 and 7) 2/10 $\mu\text{s}$ (Telcordia GR-1089-CORE, 2/10 $\mu\text{s}$ voltage wave shape) 5/310 $\mu\text{s}$ (ITU-T K.44, 10/700 $\mu\text{s}$ voltage wave shape used in K.20/21/45) 10/1000 $\mu\text{s}$ (Telcordia GR-1089-CORE, 10/1000 $\mu\text{s}$ voltage wave shape)	$I_{PPSM}$	500 150 100	A
Non-repetitive peak on-state current, 50/60 Hz (see Notes 5, 6, 7 and 8) 10 ms 1 s 7 s 900 s	$I_{TSM}$	60 14 7 3.5	A
Junction temperature	$T_J$	-55 to +150	$^\circ\text{C}$
Storage temperature range	$T_{stg}$	-65 to +150	$^\circ\text{C}$

- NOTES: 5. Initially the device must be in thermal equilibrium with  $T_J = 25\text{ }^\circ\text{C}$ . The surge may be repeated after the device returns to its initial conditions.
6. These non-repetitive rated currents are peak values. The rated current values may be applied to any cathode-anode terminal pair.
7. Rated currents only apply if pins 1 & 8 (A1, Tip) are connected together, pins 4 & 5 (A2, Ring) are connected together and pins 6 & 7 (K, Ground) are connected together.
8. These non-repetitive rated terminal currents are for the TISP8200HDM and TISP8201HDM together. Device (A)-terminal positive current values are conducted by the TISP8201HDM and (K)-terminal negative current values by the TISP8200HDM.

## Recommended Operating Conditions

See Figure 3	Min	Typ	Max	Unit
C1, C2 Gate decoupling capacitor		220		nF

## TISP8200HDM Electrical Characteristics, $T_A = 25\text{ }^\circ\text{C}$ (Unless Otherwise Noted)

Parameter	Test Conditions	Min	Typ	Max	Unit
$I_{DRM}$ Repetitive peak off-state current	$V_D = V_{DRM}$ , $V_{GK} = 0$			-5	$\mu\text{A}$
$I_{RRM}$ Repetitive peak reverse current	$V_R = V_{RRM}$ , $V_{GA} = -70\text{ V}$			5	$\mu\text{A}$
$V_{(BO)}$ Breakover voltage	$dv/dt = -250\text{ V/ms}$ , $R_{SOURCE} = 300\ \Omega$ , $V_{GA} = -80\text{ V}$			-82	V
$V_{(BO)}$ Impulse breakover voltage	$dv/dt \leq -1000\text{ V}/\mu\text{s}$ , Linear voltage ramp, Maximum ramp value = -500 V $di/dt = -20\text{ A}/\mu\text{s}$ , Linear current ramp, Maximum ramp value = -10 A $V_{GA} = -80\text{ V}$			-90	V
$I_H$ Holding current	( $I_K$ ) $I_T = -1\text{ A}$ , $di/dt = 1\text{ A/ms}$ , $V_{GA} = -80\text{ V}$	-150			mA
$I_{GT}$ Gate trigger current	( $I_K$ ) $I_T = -5\text{ A}$ , $t_{p(g)} \geq 20\ \mu\text{s}$ , $V_{GA} = -80\text{ V}$			15	mA
$C_O$ Off-state capacitance	$f = 1\text{ MHz}$ , $V_d = 1\text{ V rms}$ , Gate open	$V_D = -2\text{ V}$		65	pF
		$V_D = -50\text{ V}$		30	

# TISP820xHDM Overvoltage Protectors

**BOURNS®**

## TISP8201HDM Electrical Characteristics, $T_A = 25\text{ }^\circ\text{C}$ (Unless Otherwise Noted)

Parameter		Test Conditions	Min	Typ	Max	Unit
$I_{DRM}$	Repetitive peak off-state current	$V_D = V_{DRM}, V_{GK} = 0$			5	$\mu\text{A}$
$I_{RRM}$	Repetitive peak reverse current	$V_R = V_{RRM}, V_{GK} = 70\text{ V}$			-5	$\mu\text{A}$
$V_{(BO)}$	Breakover voltage	$dv/dt = 250\text{ V/ms}, R_{SOURCE} = 300\ \Omega, V_{GK} = 80\text{ V}$			82	V
$V_{(BO)}$	Impulse breakover voltage	$dv/dt \leq 1000\text{ V}/\mu\text{s}$ , Linear voltage ramp, Maximum ramp value = 500 V $di/dt = 20\text{ A}/\mu\text{s}$ , Linear current ramp, Maximum ramp value = 10 A $V_{GK} = 80\text{ V}$			90	V
$I_H$	Holding current	( $I_A$ ) $I_T = 1\text{ A}, di/dt = -1\text{ A/ms}, V_{GK} = 80\text{ V}$	20			mA
$I_{GT}$	Gate trigger current	( $I_A$ ) $I_T = 5\text{ A}, t_{p(g)} \geq 20\ \mu\text{s}, V_{GK} = 80\text{ V}$			-15	mA
$C_O$	Off-state capacitance	$f = 1\text{ MHz}, V_d = 1\text{ V rms}, \text{Gate open}$			50	pF
					30	

## Thermal Characteristics

Parameter		Test Conditions	Min	Typ	Max	Unit
$R_{\theta JA}$	Junction to ambient thermal resistance	EIA/JESD51-7 PCB, EIA/JESD51-2 Environment, $P_{TOT} = 4\text{ W}$ (See Note 9)		55		$^\circ\text{C/W}$

NOTE 9. EIA/JESD51-7 high effective thermal conductivity test board (multi-layer) connected with 0.6 mm printed wiring track widths.

## Parameter Measurement Information

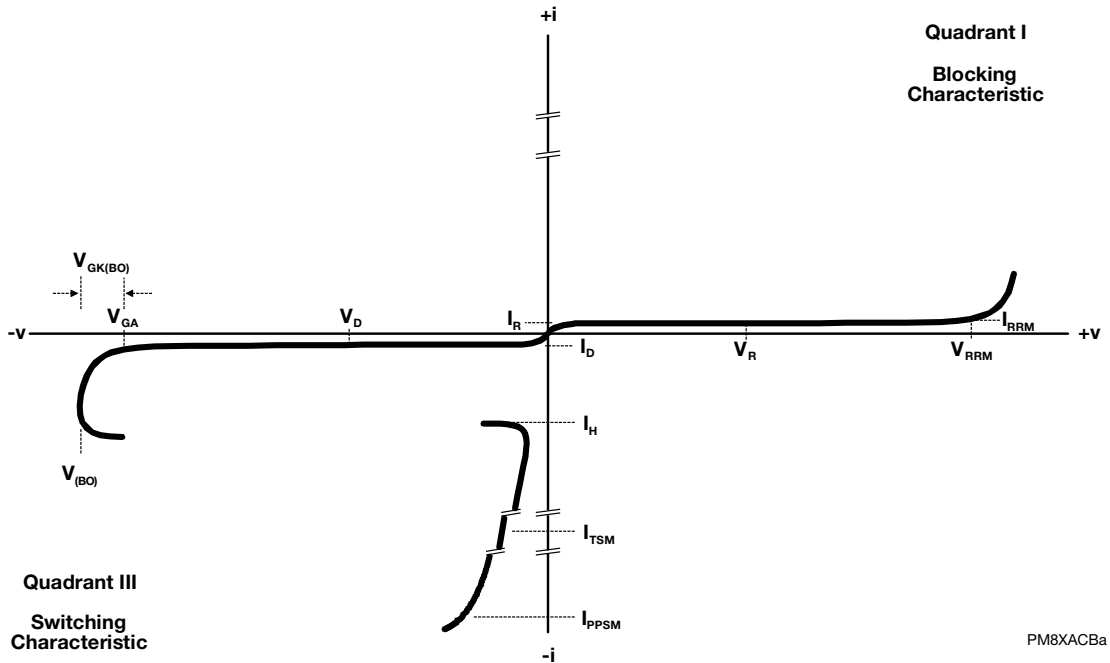

Figure 1. TISP8200HDM KA Terminal Characteristic

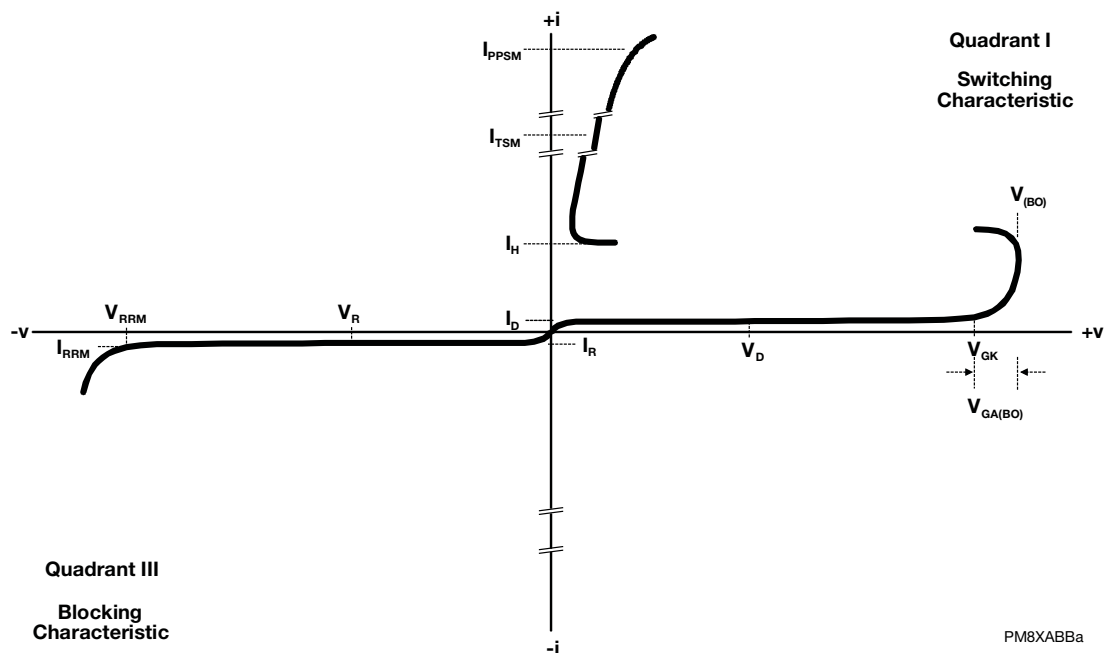

Figure 2. TISP8201HDM AK Terminal Characteristic

# TISP820xHDM Overvoltage Protectors

**BOURNS®**

## Applications Information

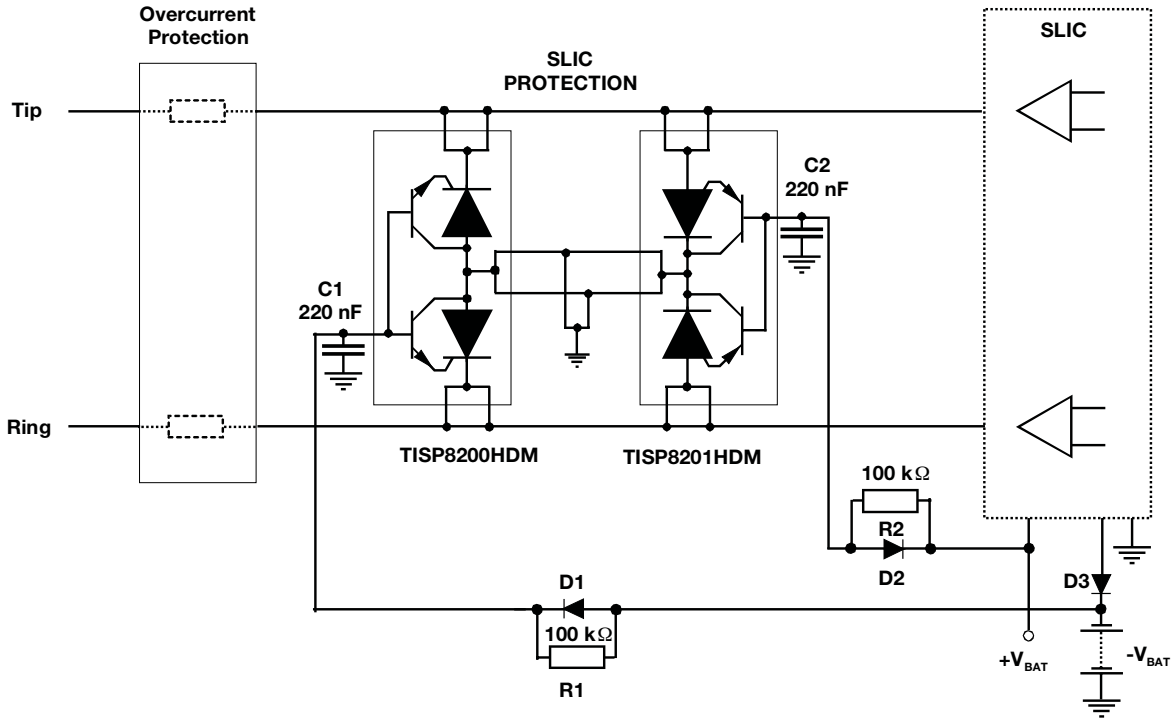

Figure 3. Typical Application Circuit

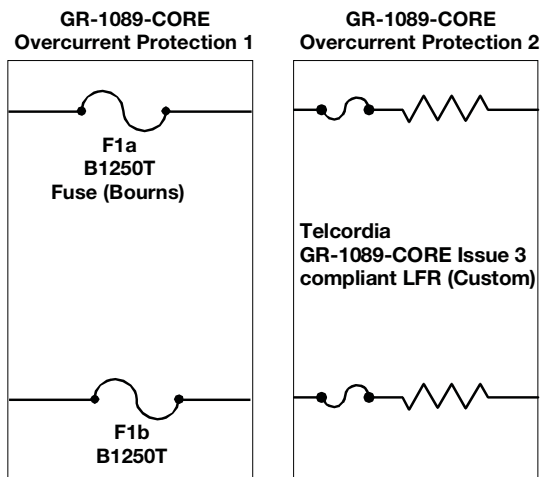

Figure 4. Typical Overcurrent Protection

AI-TISP8-001-b

### **Bourns Sales Offices**

<u>Region</u>	<u>Phone</u>	<u>Fax</u>
The Americas:	+1-951-781-5500	+1-951-781-5700
Europe:	+41-41-7685555	+41-41-7685510
Asia-Pacific:	+886-2-25624117	+886-2-25624116

### **Technical Assistance**

<u>Region</u>	<u>Phone</u>	<u>Fax</u>
The Americas:	+1-951-781-5500	+1-951-781-5700
Europe:	+41-41-7685555	+41-41-7685510
Asia-Pacific:	+886-2-25624117	+886-2-25624116

### **[www.bourns.com](http://www.bourns.com)**

Bourns® products are available through an extensive network of manufacturer's representatives, agents and distributors. To obtain technical applications assistance, a quotation, or to place an order, contact a Bourns representative in your area.



*Reliable Electronic Solutions*

Компания «Океан Электроники» предлагает заключение долгосрочных отношений при поставках импортных электронных компонентов на взаимовыгодных условиях!

Наши преимущества:

- Поставка оригинальных импортных электронных компонентов напрямую с производств Америки, Европы и Азии, а так же с крупнейших складов мира;
- Широкая линейка поставок активных и пассивных импортных электронных компонентов (более 30 млн. наименований);
- Поставка сложных, дефицитных, либо снятых с производства позиций;
- Оперативные сроки поставки под заказ (от 5 рабочих дней);
- Экспресс доставка в любую точку России;
- Помощь Конструкторского Отдела и консультации квалифицированных инженеров;
- Техническая поддержка проекта, помощь в подборе аналогов, поставка прототипов;
- Поставка электронных компонентов под контролем ВП;
- Система менеджмента качества сертифицирована по Международному стандарту ISO 9001;
- При необходимости вся продукция военного и аэрокосмического назначения проходит испытания и сертификацию в лаборатории (по согласованию с заказчиком);
- Поставка специализированных компонентов военного и аэрокосмического уровня качества (Xilinx, Altera, Analog Devices, Intersil, Interpoint, Microsemi, Actel, Aeroflex, Peregrine, VPT, Syfer, Eurofarad, Texas Instruments, MS Kennedy, Miteq, Cobham, E2V, MA-COM, Hittite, Mini-Circuits, General Dynamics и др.);

Компания «Океан Электроники» является официальным дистрибьютором и эксклюзивным представителем в России одного из крупнейших производителей разъемов военного и аэрокосмического назначения «JONHON», а так же официальным дистрибьютором и эксклюзивным представителем в России производителя высокотехнологичных и надежных решений для передачи СВЧ сигналов «FORSTAR».



## JONHON

«JONHON» (основан в 1970 г.)

Разъемы специального, военного и аэрокосмического назначения:

(Применяются в военной, авиационной, аэрокосмической, морской, железнодорожной, горно- и нефтедобывающей отраслях промышленности)

«FORSTAR» (основан в 1998 г.)

ВЧ соединители, коаксиальные кабели, кабельные сборки и микроволновые компоненты:

(Применяются в телекоммуникациях гражданского и специального назначения, в средствах связи, РЛС, а так же военной, авиационной и аэрокосмической отраслях промышленности).



Телефон: 8 (812) 309-75-97 (многоканальный)

Факс: 8 (812) 320-03-32

Электронная почта: [ocean@oceanchips.ru](mailto:ocean@oceanchips.ru)

Web: <http://oceanchips.ru/>

Адрес: 198099, г. Санкт-Петербург, ул. Калинина, д. 2, корп. 4, лит. А