



Automotive Direction Indicator

The MC33193 is a new generation industry standard UAA1041 "Flasher". It has been developed for enhanced EMI sensitivity, system reliability, and improved wiring simplification. The MC33193 is pin compatible with the UAA1041 and UAA1041B in the standard application configuration as shown in Figure 9, without lamp short circuit detection and using a 20 mΩ shunt resistor. The MC33193 has a standby mode of operation requiring very low standby supply current and can be directly connected to the vehicle's battery. It includes an RF filter on the Fault detection pin (Pin 7) for EMI purposes. Fault detection thresholds are reduced relative to those of the UAA1041, allowing a lower shunt resistance value (20 mΩ) to be used.

- Pin Compatible with the UAA1041
- Defective Lamp Detection Threshold
- RF Filter for EMI Purposes
- Load Dump Protection
- Double Battery Capability for Jump Start Protection
- Internal Free Wheeling Diode Protection
- Low Standby Current Mode

MC33193

AUTOMOTIVE DIRECTION INDICATOR

SEMICONDUCTOR TECHNICAL DATA



D SUFFIX
PLASTIC PACKAGE
CASE 751
(SO-8)

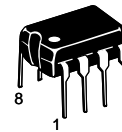

P SUFFIX
PLASTIC PACKAGE
CASE 626

Simplified Block Diagram

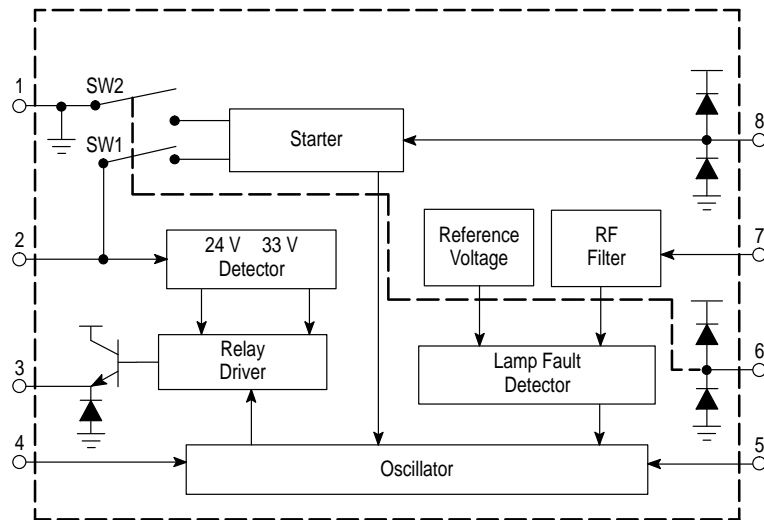

This device contains 60 active transistors.

PIN CONNECTIONS

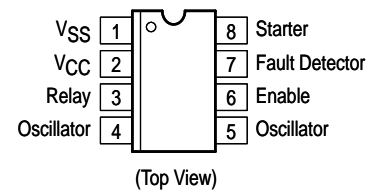

ORDERING INFORMATION

Device	Operating Temperature Range	Package
MC33193D	T _A = -40° to 125°C	SO-8
MC33193P		DIP-8

MAXIMUM RATINGS

Rating	Symbol	Value	Unit
Pin 1 Positive Current (Continuous/Pulse)	I1+	150 to 500	mA
Pin 1 Negative Current (Continuous/Pulse)	I1-	-35 to -500	mA
Pin 2 Current (Continuous/Pulse)	I2	±350 to ±1900	mA
Pin 3 Current (Continuous/Pulse)	I3	±300 to ±1400	mA
Pin 8 Current (Continuous/Pulse)	I8	±25 to ±50	mA
ESD (All Pins Except Pin 4 for Negative Pulse)	V _{ESD}	±2000	V
ESD (Pin 4 Negative Pulse)	V _{ESD4-}	-1000	V
Junction Temperature	T _J	150	°C
Operation Ambient Temperature Range	T _A	-40 to 125	°C
Storage Temperature Range	T _{stg}	-65 to 150	°C

NOTE: ESD data available upon request.

ELECTRICAL CHARACTERISTICS (-40°C ≤ T_A ≤ 125°C, 8.0 V ≤ V_{CC} ≤ 18 V, unless otherwise noted. Typical values reflect approximate mean at T_A = 25°C, V_{CC} = 14 V at the time of initial device characterization.)

Characteristic	Symbol	Min	Typ	Max	Unit
Battery Voltage Range (Normal Operation)	V _b	8.0	-	18	V
Overvoltage Detector Threshold (V _{Pin2} - V _{Pin1})	V _{ih}	19	20.2	22	V
Clamping Voltage (R2 = 220 Ω)	V _{cl}	27	29.2	34	V
Output Voltage [I = -250 mA (V _{Pin2} - V _{Pin3})]	V _{sat}	-	-	1.5	V
Starter Resistance (R _{st} = R2 + R _{Lamp})	R _{st}	-	3.3	3.6	kΩ
Oscillator Constant (Normal Operation, T _A = 25°C)	K _n	1.3	1.5	1.75	X
Temperature Coefficient of K _n	TC _{Kn}	-	0.001	-	1/°C
Duty Cycle (Normal Operation)	-	45	50	55	%
Oscillator Constant (One 21 W Lamp Defect, T _A = 25°C)	K _f	0.63	0.68	0.73	X
Duty Cycle (One 21 W Lamp Defect)	-	35	40	45	%
Oscillator Constant (T _A = 25°C)	K1 K2	0.167 0.250	0.180 0.270	0.193 0.290	-
Standby Current (Ignition "Off")	I _{CC}	-	2.0	100	μA
Current Consumption (Relay "Off," Enable Pin 6 High) V _{bat} = 8.0 V, R3 = 220 Ω, T _A = 25°C V _{bat} = 13.5 V, R3 = 220 Ω V _{bat} = 18 V, R3 = 220 Ω, T _A = 25°C	I _{CC}	-	1.40 2.16 2.64	- 3.5 -	mA
Current Consumption (Relay "On") V _{bat} = 8.0 V, R3 = 220 Ω, T _A = 25°C V _{bat} = 13.5 V, R3 = 220 Ω V _{bat} = 18 V, R3 = 220 Ω, T _A = 25°C	I _{CC}	-	1.62 2.06 3.30	- 6.0 -	mA
Defect Lamp Detector Threshold [R3 = 220 Ω, (V _{Pin2} - V _{Pin7})] V _{bat} = 8.0 V, T _A = 25°C V _{bat} = 13.5 V V _{bat} = 18 V, T _A = 25°C	V _S	- 46.5 -	43.6 51.0 57.0	- 56 -	mV
Temperature Coefficient of V _S	TC _{Vs}	-	0.3 x 10 ⁻³	-	1/°C

Figure 1. Normal Operation Oscillator Timing Diagram

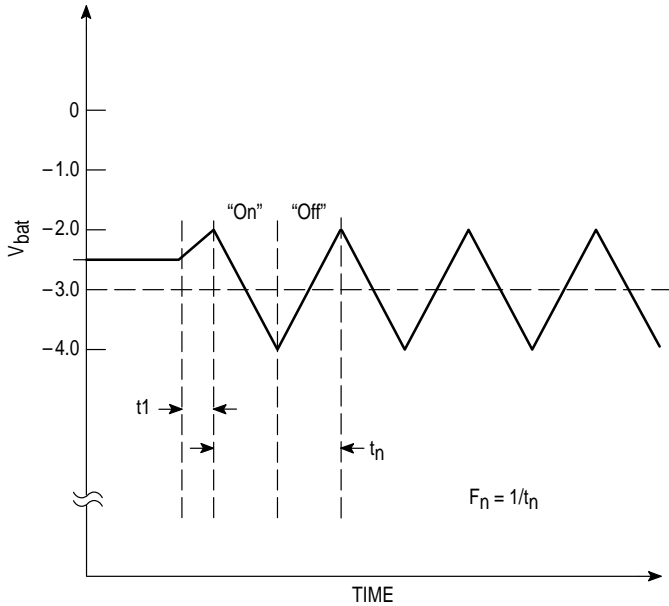
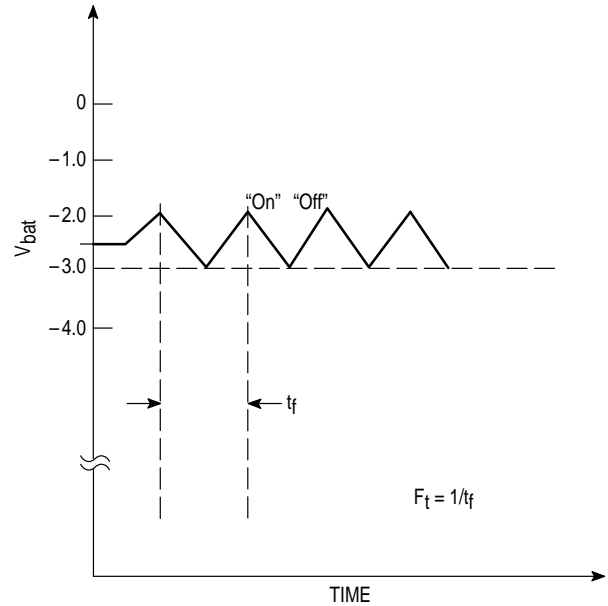

Figure 2. One Defective Lamp Oscillator Timing Diagram



INTRODUCTION

The MC33193 is designed to drive the direction indicator flasher relay. It is a new generation industry standard UAA1041 "Flasher". It consists of the following functions:

- Supply and Protections
- On-Chip Relay Driver
- Oscillator
- Starter Functions
- Lamp Fault Detector with Internal RF Filter
- Standby Mode

Supply and Protection Systems

Pin 1 is connected to ground via resistor R3 which limits the current in the event of any high voltage transients. Pin 2 (V_{CC}) is the positive supply and may be connected directly to the vehicle's battery voltage.

Overvoltage and Double Battery Protection: When the applied V_{CC} to V_{SS} voltage is greater than 22 V, the overvoltage detector circuit turns the relay driver off. Both the device and the lamps are protected if two 12 V batteries are connected in series and used to jump start the vehicle.

Load Dump Overvoltage Protection: A 29 V overvoltage detector protects the circuits against high voltage transients due to load dumps and other low energy spikes. The relay driver is automatically turned on whenever the V_{CC} to V_{SS} voltage is greater than 34 V.

Overvoltage Protection, High Voltage Transients: The Enable and the Starter pins are protected against positive and negative transients by internal on-chip diodes.

On-Chip Relay Driver

The device directly drives the flasher relay. The output structure is an Emitter of an NPN transistor. It contains the free wheeling diode circuitry necessary to protect the device whenever the relay is switched off.

Oscillator

The device uses a sawtooth oscillator (Figure 1).

The frequency is determined by the external components C1 and R1. In the normal operating mode, the flashing frequency is: $F_n = 1/R1 * C1 * K_n$. With a defective (open) 21 W lamp (Figure 2), the flashing frequency changes to: $F_t = 2.2 * F_n$.

The typical first flash delay (the time between the moment when the indicator switch is closed and the first lamp flash occurs) is: $t_1 = K_1 * R1 * C1$

The fault detection delay is from the time relay R1 is on and fault detection is enabled. Where a 21 W lamp opens, the delay is expressed as: $t_2 = K_2 * R1 * C1$

Starter

Pin 8 is connected through a 3.3 kΩ resistor to the flashing lamp. Pin 8 is the input to the Starter function and senses the use of S1 by sensing ground through the lamp (Figures 9 and 10).

Lamp Fault Detector with Internal RF Filter

A Lamp defect is sensed by the lamp fault detector's monitoring of the voltage developed across the external shunt resistor R_S via the RF filter. The R_S voltage drop is compared to a V_{bat} dependent internal reference voltage (V_{ref}) to validate the comparison over the full battery voltage range. A detected fault causes the oscillator to change frequency (Figure 2).

Standby Mode

When the ignition key and warning switches are open; Enable is in a low state and the internal switches, SW1 and SW2, are open and no current passes through the circuit. In this condition, the device's current consumption is zero ($I_{CC} = 0$). When ignition key and warning switches are closed; Enable is in a high state with SW1 and SW2 being closed and the circuit is powered on.

Figure 3. Clamping Voltage versus Temperature

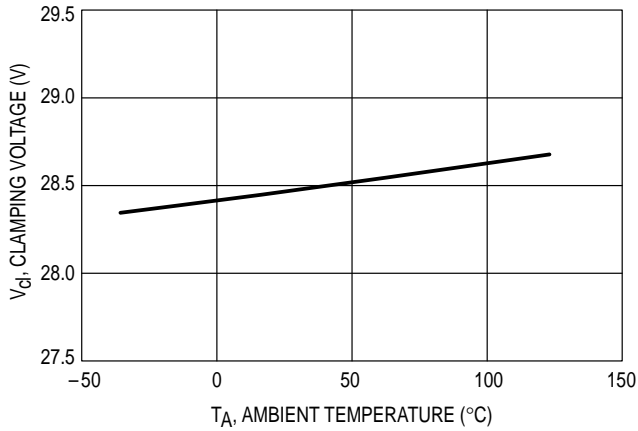

Figure 4. Overvoltage Detection versus Temperature

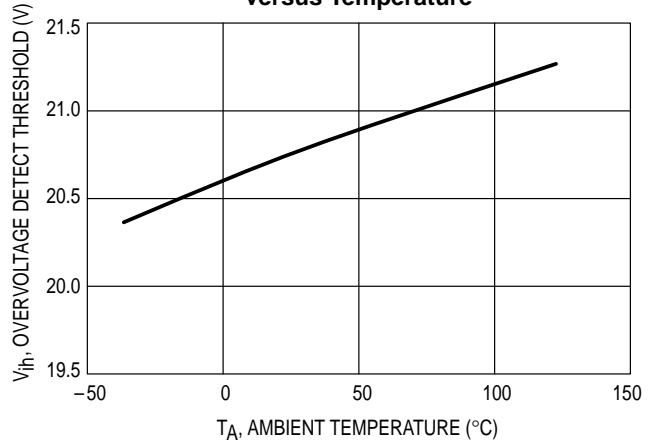

Figure 5. Supply Current versus Temperature

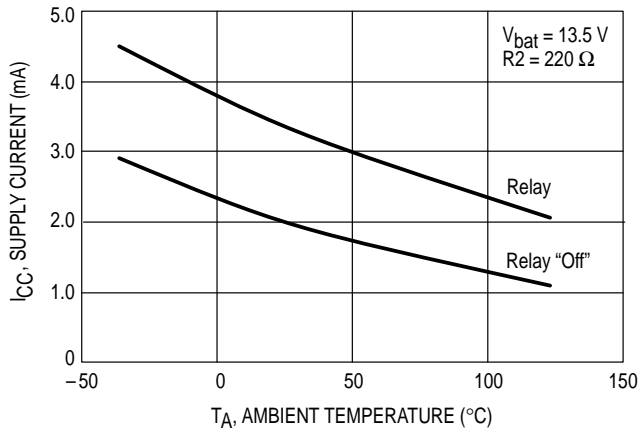

Figure 6. Output Voltage versus Temperature

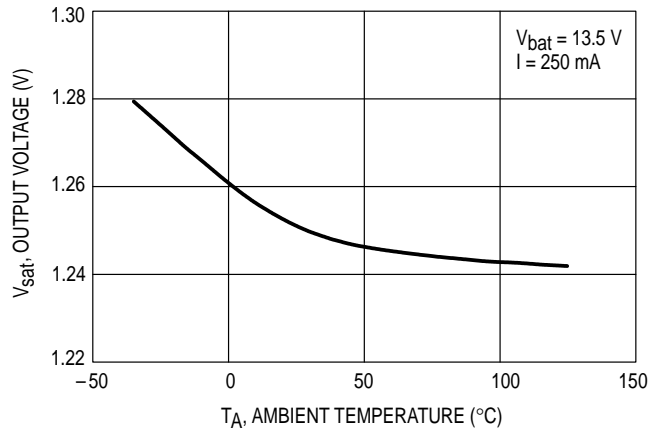

Figure 7. Defect Lamp Detection versus Temperature

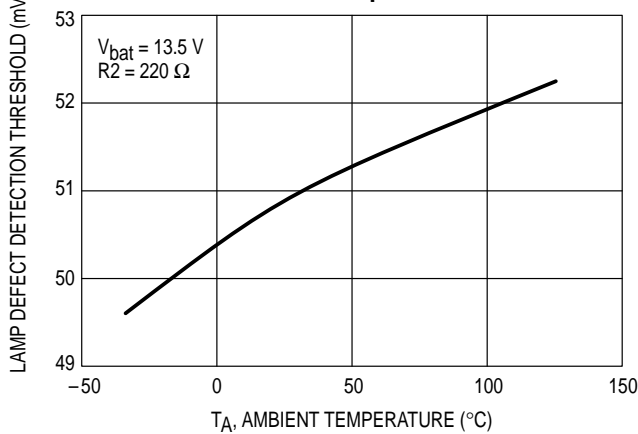

Figure 8. Oscillator Constant versus Temperature

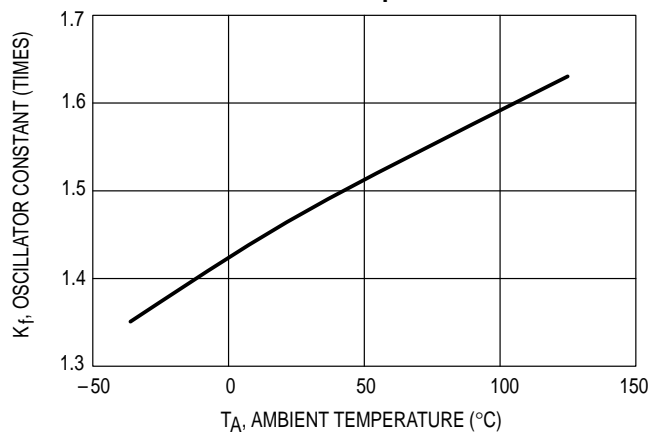
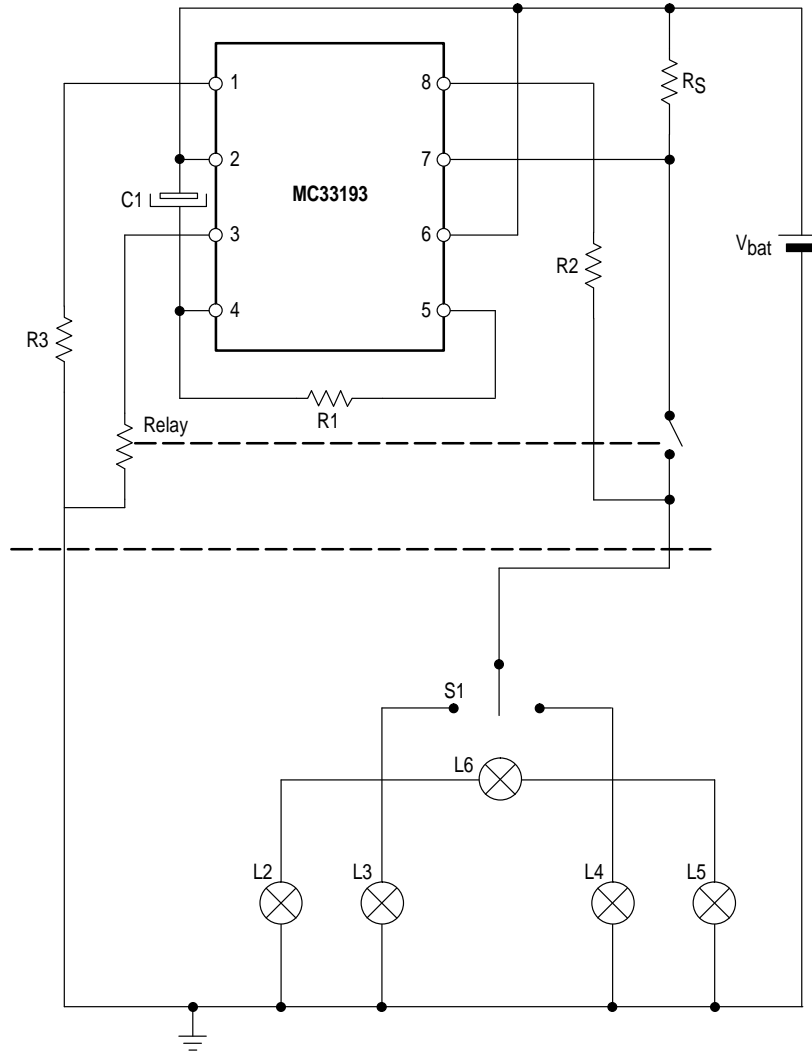

Figure 9. MC33193 Typical Application



$R_S = 20 \text{ m}\Omega$
 $R_1 = 75 \text{ k}\Omega$
 $C_1 = 5.6 \text{ }\mu\text{F}$
 $R_2 = 3.3 \text{ k}\Omega$
 $R_3 = 200 \text{ }\Omega$
 $L_2, L_3, L_4, L_5 = 21 \text{ W Turn Signal Lamps}$

Application Information

- NOTES:**
1. In the above application, the MC33193 is compatible with the UAA1041 and UAA1041B except for the shunt resistor value ($R_S = 20 \text{ m}\Omega$).
 2. The flashing cycle is started by the closing of switch S1.
 3. The position of switch S1 is sensed across resistor R2 and R_{Lamp} by the input, Pin 8.

Figure 10. Typical MC33193 Application

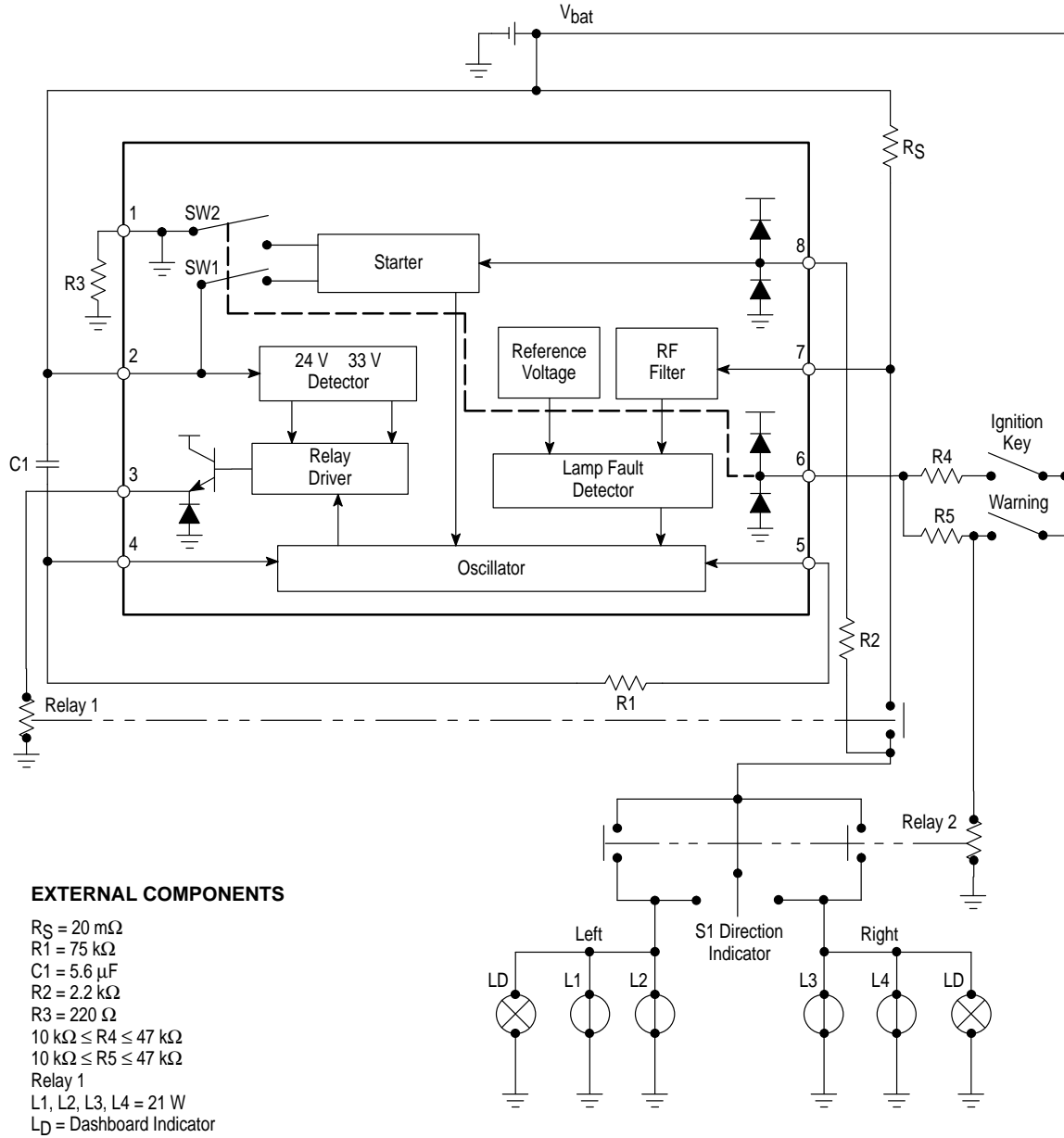

Application Information

- NOTES:**
1. The flashing cycle is started by the closing of switch S1.
 2. The S1 switch position is sensed across the resistor R2 and R_{Lamp} by the input (Pin 8).
 3. If the logic state at Pin 6 is [0], the current through R2 is off.

OUTLINE DIMENSIONS

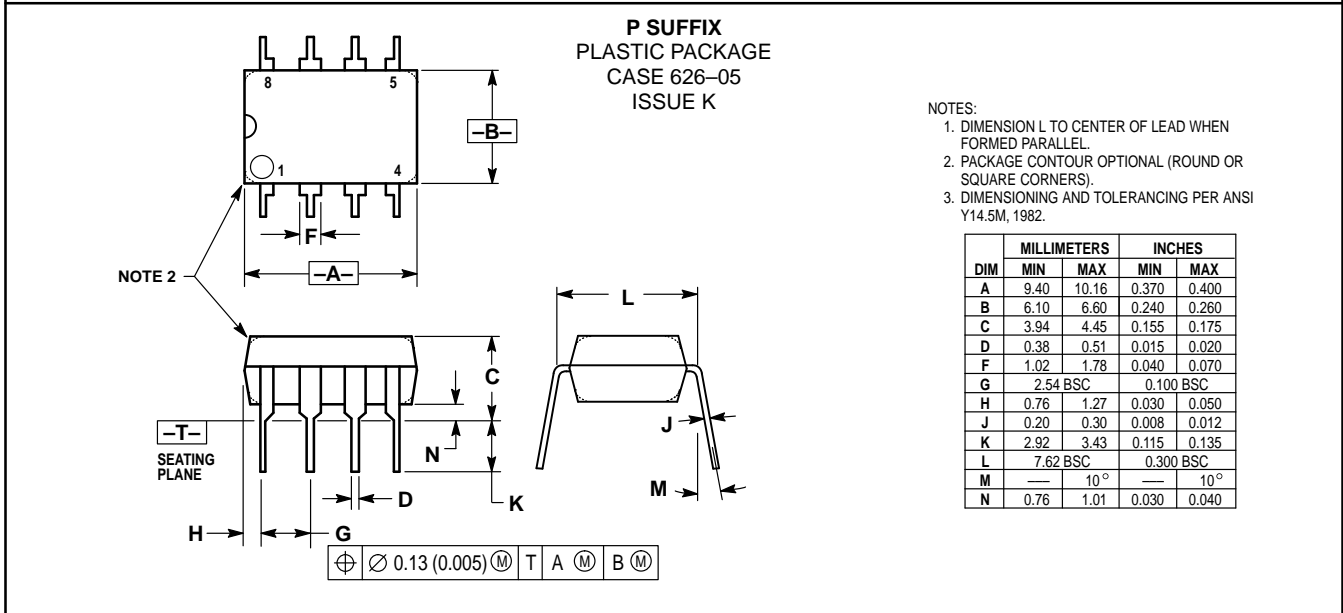
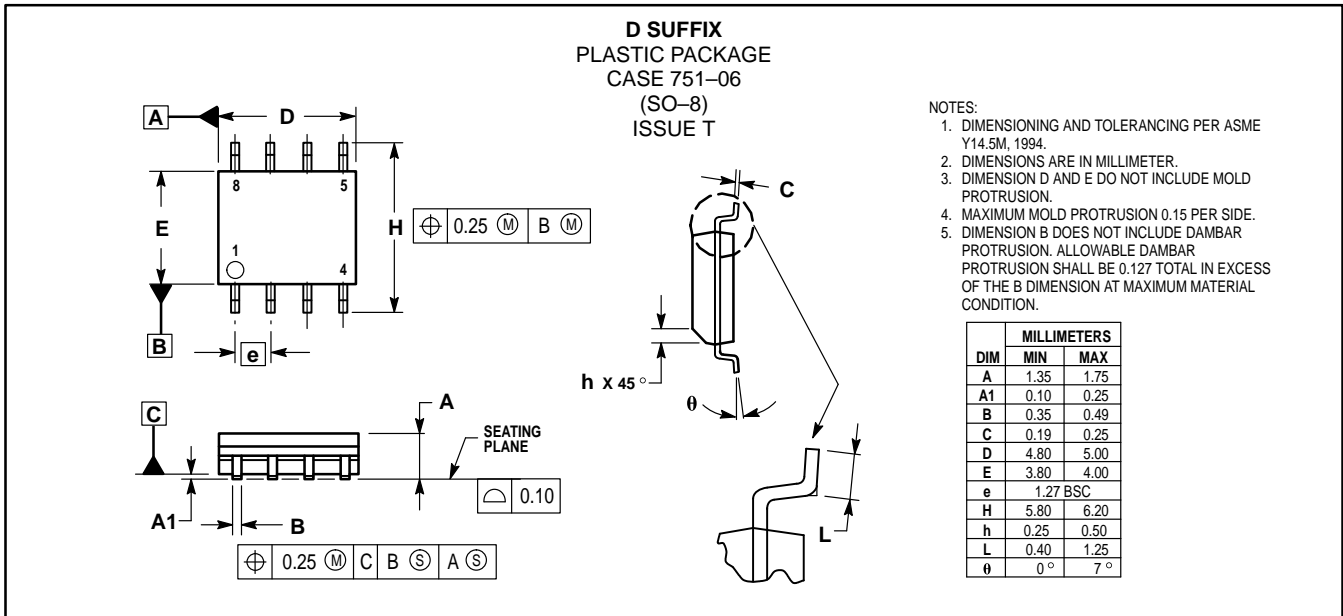

Motorola reserves the right to make changes without further notice to any products herein. Motorola makes no warranty, representation or guarantee regarding the suitability of its products for any particular purpose, nor does Motorola assume any liability arising out of the application or use of any product or circuit, and specifically disclaims any and all liability, including without limitation consequential or incidental damages. "Typical" parameters which may be provided in Motorola data sheets and/or specifications can and do vary in different applications and actual performance may vary over time. All operating parameters, including "Typicals" must be validated for each customer application by customer's technical experts. Motorola does not convey any license under its patent rights nor the rights of others. Motorola products are not designed, intended, or authorized for use as components in systems intended for surgical implant into the body, or other applications intended to support or sustain life, or for any other application in which the failure of the Motorola product could create a situation where personal injury or death may occur. Should Buyer purchase or use Motorola products for any such unintended or unauthorized application, Buyer shall indemnify and hold Motorola and its officers, employees, subsidiaries, affiliates, and distributors harmless against all claims, costs, damages, and expenses, and reasonable attorney fees arising out of, directly or indirectly, any claim of personal injury or death associated with such unintended or unauthorized use, even if such claim alleges that Motorola was negligent regarding the design or manufacture of the part. Motorola and are registered trademarks of Motorola, Inc. Motorola, Inc. is an Equal Opportunity/Affirmative Action Employer.

Mfax is a trademark of Motorola, Inc.

How to reach us:

USA/EUROPE/Locations Not Listed: Motorola Literature Distribution;
P.O. Box 5405, Denver, Colorado 80217. 1-303-675-2140 or 1-800-441-2447

JAPAN: Nippon Motorola Ltd.; SPD, Strategic Planning Office, 141,
4-32-1 Nishi-Gotanda, Shinagawa-ku, Tokyo, Japan. 81-3-5487-8488

Customer Focus Center: 1-800-521-6274

Mfax™: RMFAX0@email.sps.mot.com – TOUCHTONE 1-602-244-6609
Motorola Fax Back System – US & Canada ONLY 1-800-774-1848
– http://sps.motorola.com/mfax/

ASIA/PACIFIC: Motorola Semiconductors H.K. Ltd.; 8B Tai Ping Industrial Park,
51 Ting Kok Road, Tai Po, N.T., Hong Kong. 852-26629298

HOME PAGE: http://motorola.com/sps/



**For More Information On This Product,
Go to: www.freescale.com**

Компания «Океан Электроники» предлагает заключение долгосрочных отношений при поставках импортных электронных компонентов на взаимовыгодных условиях!

Наши преимущества:

- Поставка оригинальных импортных электронных компонентов напрямую с производств Америки, Европы и Азии, а так же с крупнейших складов мира;
- Широкая линейка поставок активных и пассивных импортных электронных компонентов (более 30 млн. наименований);
- Поставка сложных, дефицитных, либо снятых с производства позиций;
- Оперативные сроки поставки под заказ (от 5 рабочих дней);
- Экспресс доставка в любую точку России;
- Помощь Конструкторского Отдела и консультации квалифицированных инженеров;
- Техническая поддержка проекта, помощь в подборе аналогов, поставка прототипов;
- Поставка электронных компонентов под контролем ВП;
- Система менеджмента качества сертифицирована по Международному стандарту ISO 9001;
- При необходимости вся продукция военного и аэрокосмического назначения проходит испытания и сертификацию в лаборатории (по согласованию с заказчиком);
- Поставка специализированных компонентов военного и аэрокосмического уровня качества (Xilinx, Altera, Analog Devices, Intersil, Interpoint, Microsemi, Actel, Aeroflex, Peregrine, VPT, Syfer, Eurofarad, Texas Instruments, MS Kennedy, Miteq, Cobham, E2V, MA-COM, Hittite, Mini-Circuits, General Dynamics и др.);

Компания «Океан Электроники» является официальным дистрибьютором и эксклюзивным представителем в России одного из крупнейших производителей разъемов военного и аэрокосмического назначения «JONHON», а так же официальным дистрибьютором и эксклюзивным представителем в России производителя высокотехнологичных и надежных решений для передачи СВЧ сигналов «FORSTAR».



JONHON

«JONHON» (основан в 1970 г.)

Разъемы специального, военного и аэрокосмического назначения:

(Применяются в военной, авиационной, аэрокосмической, морской, железнодорожной, горно- и нефтедобывающей отраслях промышленности)

«FORSTAR» (основан в 1998 г.)

ВЧ соединители, коаксиальные кабели, кабельные сборки и микроволновые компоненты:

(Применяются в телекоммуникациях гражданского и специального назначения, в средствах связи, РЛС, а так же военной, авиационной и аэрокосмической отраслях промышленности).



Телефон: 8 (812) 309-75-97 (многоканальный)

Факс: 8 (812) 320-03-32

Электронная почта: ocean@oceanchips.ru

Web: <http://oceanchips.ru/>

Адрес: 198099, г. Санкт-Петербург, ул. Калинина, д. 2, корп. 4, лит. А