



Discontinued: Wire leads type with agency standard
Last time buy: August 31, 2012



Panasonic
ideas for life

HIGH ENVIRONMENTAL
RESISTANCE

TURQUOISE SWITCHES
ABJ TYPE

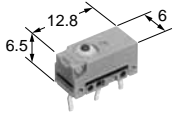

Dust protected type



(Mounting hole
2.3mm type)



Immersion protected type
(wire leads bottom type)



(Mounting hole
2.3mm type)



Immersion protected
(wire leads side type)



Long stroke type

RoHS compliant

FEATURES

- Ultra-miniature size (12.8×6.5×6 mm)
- Sealed construction for use in adverse environment-Sealed construction by epoxy resin and rubber cap greatly reduces possible miscontact due to contaminants such as dust. Conforming to IP67* of IEC protective construction classification
- Elastomer double molding technology, an industry first and ultrasonic swaging technology contribute to uniform sealing in high production quantities
- UL/CSA approved (Except the long stroke type of ABJ2 and the side wire leads type.)
- Long stroke type is available
Since the repeatability is excellent and the play distance (overtravel) from the operating position is ample, the task of performing adjustments during installation is easy.
Operating position accuracy ±0.4 mm
Overtravel= Min. 2.0 mm
As wide range of high pressure is achieved, a stable reliability is ensured
- Leaf lever side wire leads type added. We now offer two types.
M3 type installation hole
Fixed pin type

TYPICAL APPLICATIONS

- Industrial use video jack
 - Automotive (ex. Device for opening and shutting of automobile doors)
- * Based on the protective construction classification of IEC, items which satisfy the test requirements are denoted with an IP designation.

ORDERING INFORMATION

(If Agency standard required, please refer to the "with Agency standard type". See next page.)

Ex. ABJ 1 4 1 0 4 0

Type of switch	Size of mounting hole	Terminal	Contact arrangement	Actuator	Operating force by pin plunger (max.)	Contact
ABJ: Turquoise switch J type	1: 1.2 mm 2: 2.3 mm 3: 3 mm 4: Fixed pin (right side pin) type 5: Fixed pin (left side pin) type	4: Solder terminal 5: PC board terminal 6: Wire leads (bottom type) 7: Wire leads (right side type) 8: Wire leads (left side type)	1: SPDT 2: SPST-NC (Wire leads type only) 3: SPST-NO (Wire leads type only)	0: Pin plunger 2: Hinge lever 4: Simulated roller lever 6: Roller lever 8: Leaf lever (Mounting hole 3 mm lead wire type only) L: Long stroke type	4: 1.23 N 6: 1.96 N 7: 2.45 N (Long stroke type only)	0: AgNi alloy 1: AgNi alloy + Au clad

Remarks: 1. Standard packing: Dust protected type 100 pcs./carton, 2,000 pcs./case; Immersion protected type 50 pcs./case.
2. Not every combination is available. Please refer to the following table, "PRODUCT TYPES".



Discontinued: Wire leads type with agency standard
Last time buy: August 31, 2012

ABJ1,2,3,4,5

With Agency standard type

Ex. ABJ 1 4 1 0 4 0 9

Type of switch	Size of mounting hole	Terminal	Contact arrangement	Actuator	Operating force by pin plunger (max.)	Contact	Agency standard
ABJ: Turquoise switch J type	1: 1.2 mm 2: 2.3 mm 3: 3 mm	4: Solder terminal 5: PC board terminal 6: Wire leads (bottom type)	1: SPDT 2: SPST-NC (Wire leads type only) 3: SPST-NO (Wire leads type only)	0: Pin plunger 2: Hinge lever 4: Simulated roller lever 6: Roller lever 8: Leaf lever (Mounting hole 3 mm lead wire type only)	4: 1.23 N 6: 1.96 N	0: AgNi alloy 1: AgNi alloy + Au clad	9: UL/CSA 6 × 10 ³ rated

Remarks: 1. Standard packing: Dust protected type 100 pcs./carton, 2,000 pcs./case; Immersion protected type 50 pcs./case.
 2. Not every combination is available. Please refer to the following table, "PRODUCT TYPES".
 3. Wire leads type with agency standard will be discontinued from August 31, 2012.

CONTACT ARRANGEMENT

1. SPDT

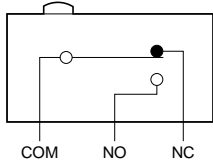

2. SPST-NC (Wire leads type only)

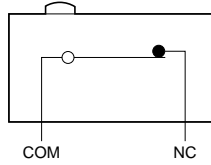

3. SPST-NO (Wire leads type only)

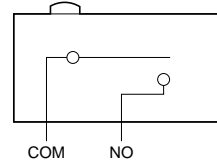

APPLICABLE CURRENT RANGE (reference)

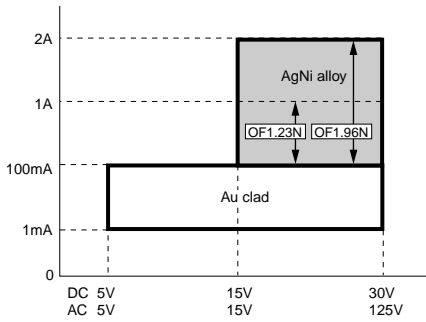

Note) OF: Value of pin plunger



Discontinued: Wire leads type with agency standard
Last time buy: August 31, 2012

ABJ1,2,3,4,5

PRODUCT TYPES

1. Dust protected type (Terminal type)

Mounting hole 1.2mm type / Mounting hole 2.3mm type

AgNi alloy

Actuator	Operating force Max.	Mounting hole 1.2 mm type		Mounting hole 2.3 mm type
		Solder terminal	PC board terminal	Solder terminal
Pin plunger	1.23 N	ABJ1410409	ABJ1510409	ABJ2410409
	1.96 N	ABJ1410609	ABJ1510609	ABJ2410609
Hinge lever	0.39 N	ABJ1412409	ABJ1512409	ABJ2412409
	0.64 N	ABJ1412609	ABJ1512609	ABJ2412609
Simulated roller lever	0.39 N	ABJ1414409	ABJ1514409	ABJ2414409
	0.64 N	ABJ1414609	ABJ1514609	ABJ2414609
Roller lever	0.39 N	ABJ1416409	ABJ1516409	ABJ2416409
	0.64 N	ABJ1416609	ABJ1516609	ABJ2416609

AgNi alloy + Au clad

Actuator	Operating force Max.	Mounting hole 1.2 mm type		Mounting hole 2.3 mm type
		Solder terminal	PC board terminal	Solder terminal
Pin plunger	1.23 N	ABJ1410419	ABJ1510419	ABJ2410419
	1.96 N	ABJ1410619	ABJ1510619	ABJ2410619
Hinge lever	0.39 N	ABJ1412419	ABJ1512419	ABJ2412419
	0.64 N	ABJ1412619	ABJ1512619	ABJ2412619
Simulated roller lever	0.39 N	ABJ1414419	ABJ1514419	ABJ2414419
	0.64 N	ABJ1414619	ABJ1514619	ABJ2414619
Roller lever	0.39 N	ABJ1416419	ABJ1516419	ABJ2416419
	0.64 N	ABJ1416619	ABJ1516619	ABJ2416619

2-(1). Immersion protected type (Bottom wire leads type) **With agency standard type will be discontinued from August 31, 2012.**

Mounting hole 1.2mm type

AgNi alloy

Actuator	Operating force Max.	Mounting hole 1.2 mm type		
		SPDT	SPST-NC	SPST-NO
Pin plunger	1.23 N	ABJ1610409	ABJ1620409	ABJ1630409
	1.96 N	ABJ1610609	ABJ1620609	ABJ1630609
Hinge lever	0.39 N	ABJ1612409	ABJ1622409	ABJ1632409
	0.64 N	ABJ1612609	ABJ1622609	ABJ1632609
Simulated roller lever	0.39 N	ABJ1614409	ABJ1624409	ABJ1634409
	0.64 N	ABJ1614609	ABJ1624609	ABJ1634609
Roller lever	0.39 N	ABJ1616409	ABJ1626409	ABJ1636409
	0.64 N	ABJ1616609	ABJ1626609	ABJ1636609

Mounting hole 2.3mm type

AgNi alloy + Au clad

Actuator	Operating force Max.	Mounting hole 1.2 mm type		
		SPDT	SPST-NC	SPST-NO
Pin plunger	1.23 N	ABJ1610419	ABJ1620419	ABJ1630419
	1.96 N	ABJ1610619	ABJ1620619	ABJ1630619
Hinge lever	0.39 N	ABJ1612419	ABJ1622419	ABJ1632419
	0.64 N	ABJ1612619	ABJ1622619	ABJ1632619
Simulated roller lever	0.39 N	ABJ1614419	ABJ1624419	ABJ1634419
	0.64 N	ABJ1614619	ABJ1624619	ABJ1634619
Roller lever	0.39 N	ABJ1616419	ABJ1626419	ABJ1636419
	0.64 N	ABJ1616619	ABJ1626619	ABJ1636619



Discontinued: Wire leads type with agency standard
Last time buy: August 31, 2012

ABJ1,2,3,4,5

Mounting hole 2.3mm type
 AgNi alloy

Actuator	Operating force Max.	Mounting hole 2.3 mm type		
		SPDT	SPST-NC	SPST-NO
Pin plunger	1.23 N	ABJ2610409	ABJ2620409	ABJ2630409
	1.96 N	ABJ2610609	ABJ2620609	ABJ2630609
Hinge lever	0.39 N	ABJ2612409	ABJ2622409	ABJ2632409
	0.64 N	ABJ2612609	ABJ2622609	ABJ2632609
Simulated roller lever	0.39 N	ABJ2614409	ABJ2624409	ABJ2634409
	0.64 N	ABJ2614609	ABJ2624609	ABJ2634609
Roller lever	0.39 N	ABJ2616409	ABJ2626409	ABJ2636409
	0.64 N	ABJ2616609	ABJ2626609	ABJ2636609

AgNi alloy + Au clad

Actuator	Operating force Max.	Mounting hole 2.3 mm type		
		SPDT	SPST-NC	SPST-NO
Pin plunger	1.23 N	ABJ2610419	ABJ2620419	ABJ2630419
	1.96 N	ABJ2610619	ABJ2620619	ABJ2630619
Hinge lever	0.39 N	ABJ2612419	ABJ2622419	ABJ2632419
	0.64 N	ABJ2612619	ABJ2622619	ABJ2632619
Simulated roller lever	0.39 N	ABJ2614419	ABJ2622419	ABJ2634419
	0.64 N	ABJ2614619	ABJ2624619	ABJ2634619
Roller lever	0.39 N	ABJ2616419	ABJ2626419	ABJ2636419
	0.64 N	ABJ2616619	ABJ2626619	ABJ2636619

Mounting hole 3mm type (Leaf lever type)

AgNi alloy

Actuator	Operating force Max.	Mounting hole 3 mm type		
		SPDT	SPST-NC	SPST-NO
Leaf lever	0.98 N	ABJ3618409	ABJ3628409	ABJ3638409
	1.27 N	ABJ3618609	ABJ3628609	ABJ3638609

AgNi alloy + Au clad

Actuator	Operating force Max.	Mounting hole 3 mm type		
		SPDT	SPST-NC	SPST-NO
Leaf lever	0.98 N	ABJ3618419	ABJ3628419	ABJ3638419
	1.27 N	ABJ3618619	ABJ3628619	ABJ3638619

2-(2). Immersion protected type (Side wire leads type)

Fixed pin (right side pin) type

AgNi alloy

Actuator	Operating force Max.	Wire leads direction	Wire leads type	
			SPST-NC	SPST-NO
Leaf lever	1.27 N	Right	ABJ472840	ABJ473840
	1.27 N	Left	ABJ482840	—
	1.76 N	Right	ABJ472860	ABJ473860
	1.76 N	Left	ABJ482860	—

AgNi alloy + Au clad

Actuator	Operating force Max.	Wire leads direction	Wire leads type	
			SPST-NC	SPST-NO
Leaf lever	1.27 N	Right	ABJ472841	ABJ473841
	1.27 N	Left	ABJ482841	—
	1.76 N	Right	ABJ472861	ABJ473861
	1.76 N	Left	ABJ482861	—



Discontinued: Wire leads type with agency standard
Last time buy: August 31, 2012

ABJ1,2,3,4,5

Fixed pin (left side pin) type
 AgNi alloy

Actuator	Operating force Max.	Wire leads direction	Wire leads type	
			SPST-NC	SPST-NO
Leaf lever	1.27 N	Right	ABJ572840	ABJ573840
	1.27 N	Left	ABJ582840	—
	1.76 N	Right	ABJ572860	ABJ573860
	1.76 N	Left	ABJ582860	—

AgNi alloy + Au clad

Actuator	Operating force Max.	Wire leads direction	Wire leads type	
			SPST-NC	SPST-NO
Leaf lever	1.27 N	Right	ABJ572841	ABJ573841
	1.27 N	Left	ABJ582841	—
	1.76 N	Right	ABJ572861	ABJ573861
	1.76 N	Left	ABJ582861	—

Mounting hole 3mm type
 AgNi alloy

Actuator	Operating force Max.	Wire leads direction	Wire leads type	
			SPST-NC	SPST-NO
Leaf lever	1.27 N	Left	ABJ382840	—
	1.76 N		ABJ382860	—

AgNi alloy + Au clad

Actuator	Operating force Max.	Wire leads direction	Wire leads type	
			SPST-NC	SPST-NO
Leaf lever	1.27 N	Left	ABJ382841	—
	1.76 N		ABJ382861	—

3. Immersion protected type (Bottom wire leads type) Long stroke type

Mounting hole 2.3mm type

AgNi alloy

Actuator	Operating force Max.	Mounting hole 2.3 mm type		
		SPDT	SPST-NC	SPST-NO
Pin plunger (Horizontal)	2.45 N	*ABJ261L70	ABJ262L70	ABJ263L70

AgNi alloy + Au clad

Actuator	Operating force Max.	Mounting hole 2.3 mm type		
		SPDT	SPST-NC	SPST-NO
Pin plunger (Horizontal)	2.45 N	*ABJ261L71	ABJ262L71	ABJ263L71

SPECIFICATIONS

1. Contact rating

Type	Operating force Max.	Standard rating	Low-level circuit rating
AgNi alloy contact	1.76 N, 1.96 N	2 A 125 V AC 2 A 30 V DC	—
	1.23 N, 1.27 N	1 A 125 V AC 1 A 30 V DC	—
Long stroke type AgNi alloy contact	2.45 N	1 A 125 V AC 1 A 30 V DC	—
AgNi alloy + Au clad contact	1.23 N, 1.27 N 1.76 N, 1.96 N	0.1 A 125 V AC	5 mA 6 V DC 2 mA 12 V DC 1 mA 24 V DC
Long stroke type AgNi alloy + Au clad contact	2.45 N	0.1 A 125 V AC 0.1 A 30 V DC	5 mA 6 V DC 2 mA 12 V DC 1 mA 24 V DC

ABJ1,2,3,4,5



Discontinued: Wire leads type with agency standard
Last time buy: August 31, 2012

2. Characteristics

Mechanical life (O.T.: Specified value)	Leaf lever, Long stroke type	Min. 5×10^5 (at 60 cpm)
	Wire leads (right & left side type)	Min. 3×10^5 (at 60 cpm)
	Other types	Min. 10^6 (at 60 cpm)
Electrical life at rated load (O.T.: max.)	AgNi alloy contact type	Min. 3×10^4 (at 20 cpm)
	AgNi alloy + Au clad contact type	Min. 10^5 (at 20 cpm)
Insulation resistance		Min. 100 M Ω (at 500 V DC insulation resistance meter)
Dielectric strength		
Between non-continuous terminals		600 Vrms
Between each terminal and other exposed metal parts		1,500 Vrms
Between each terminal and ground		1,500 Vrms
Vibration resistance (Pin plunger type)		10 to 55 Hz at single amplitude of 0.75 mm (Contact opening max. 1 msec.)
Shock resistance (Pin plunger type)		Min. 294 m/s ² {30 G} (Contact opening max. 1 msec.)
Contact resistance (Initial)	Silver contact type	Dust protected type (IP50): Max. 50 m Ω Immersion protected type (IP67): Max. 100 m Ω (By voltage drop 1 A 6 to 8 V DC)
	Gold clad contact type	Dust protected type (IP50): Max. 100 m Ω Immersion protected type (IP67): Max. 150 m Ω (By voltage drop 0.1 A 6 to 8 V DC)
Allowable operating speed (at no load)		1 to 500 mm/sec.
Max. operating cycle rate (at no load)		Other type: 120 cpm Long stroke type: 60 cpm
Ambient temperature		-40°C to +85°C
Unit weight		Approx. 0.5 g (IP50 type)
Water resistance		IP67 (Wire leads type)

3. Operating characteristics

Type of actuator	Operating force, Max.	Release force, Min	Pretravel, Max. mm	Movement differential, Max. mm	Overtravel, Min. mm	Operating position, mm
Pin plunger	1.23N	0.15N	0.6	0.12	0.25	Mounting hole: 1.2 5.5±0.2
	1.96N	0.25N				Mounting hole: 2.3 7.0±0.2
Hinge lever	0.39N	0.029N	3.0	0.5	0.5	Mounting hole: 1.2 6.8±1.0
	0.64N	0.049N				Mounting hole: 2.3 8.3±1.0
Simulated roller lever	0.39N	0.029N	3.0	0.5	0.5	Mounting hole: 1.2 9.8±1.0
	0.64N	0.049N				Mounting hole: 2.3 11.3±1.0
Roller lever	0.39N	0.029N	3.0	0.5	0.5	Mounting hole: 1.2 13.1 ±1.0
	0.64N	0.049N				Mounting hole: 2.3 14.6±1.0
Leaf lever	0.98N	0.20N	6.0	1.0	2.5	Mounting hole: 3.0 16.0±2.0
	1.27N	0.22N	2.6	0.5	1.4	Fixed pin type 10.7±0.7 Mounting hole: 3.0 16.25±0.7
	1.76N	0.26N	2.6	0.5	1.4	Fixed pin type 10.7±0.7 Mounting hole: 3.0 16.25±0.7
	1.27N	0.29N	6.0	1.0	2.5	Mounting hole: 3.0 16.0±2.0
Long stroke type	2.45N	0.20N	—	0.5	2.0	2.5±0.4

Note: The O.P. differs between the 1.2 mm and 2.3 mm dia. installation hole types.



Discontinued: Wire leads type with agency standard
 Last time buy: August 31, 2012

ABJ1,2,3,4,5

DIMENSIONS

The CAD data of the products with a **CAD Data** mark can be downloaded from: <http://industrial.panasonic.com/ac/e>

mm General tolerance: ± 0.25

1. Dust protected type

1-(1) PC board terminal

Mounting hole 1.2 mm type

Pin plunger

CAD Data

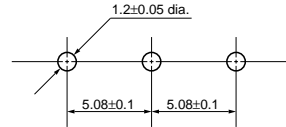
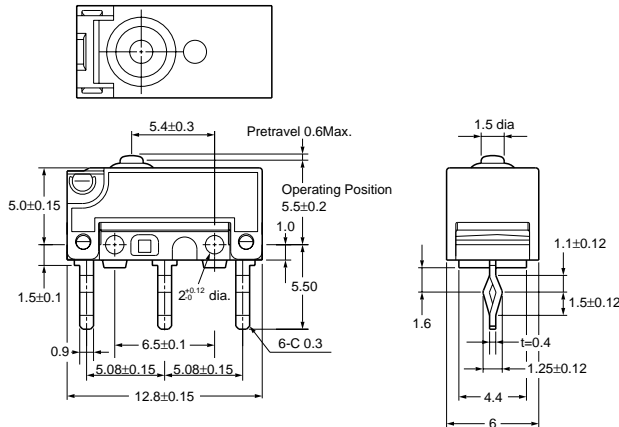

Pretravel, Max. mm		0.6
Movement differential, Max. mm		0.12
Overtravel, Min. mm		0.25
Operating position	Distance from mounting hole, mm	5.5±0.2
	Distance from stand-off, mm	7±0.3

Hinge lever

CAD Data

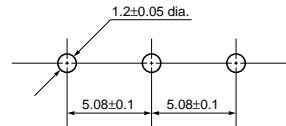
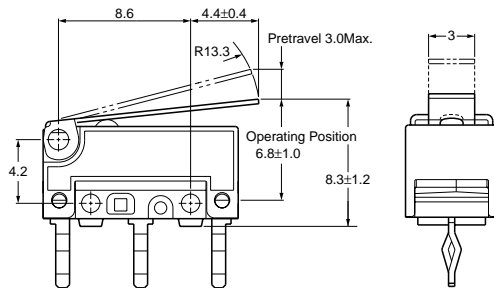

Pretravel, Max. mm		3.0
Movement differential, Max. mm		0.5
Overtravel, Min. mm		0.5
Operating position	Distance from mounting hole, mm	6.8±1.0
	Distance from stand-off, mm	8.3±1.2

Simulated roller lever

CAD Data

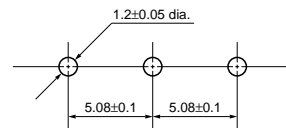
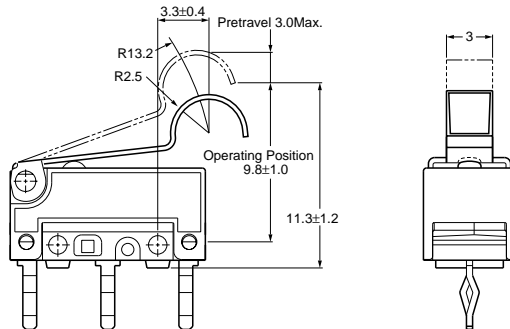

Pretravel, Max. mm		3.0
Movement differential, Max. mm		0.5
Overtravel, Min. mm		0.5
Operating position	Distance from mounting hole, mm	9.8±1.0
	Distance from stand-off, mm	11.3±1.2

Roller lever

CAD Data

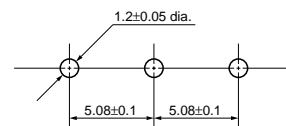
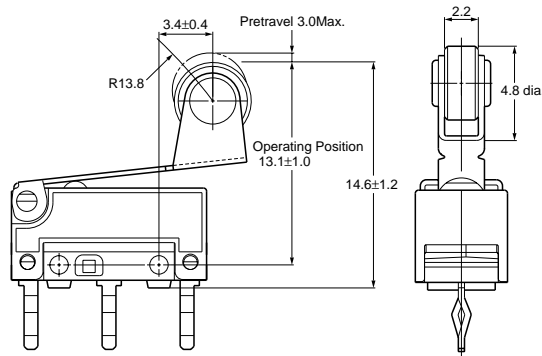

Pretravel, Max. mm		3.0
Movement differential, Max. mm		0.5
Overtravel, Min. mm		0.5
Operating position	Distance from mounting hole, mm	13.1±1.0
	Distance from stand-off, mm	14.6±1.0

ABJ1,2,3,4,5



Discontinued: Wire leads type with agency standard
Last time buy: August 31, 2012

1-(2) Solder terminal
 Pin plunger

mm General tolerance: ± 0.25

CAD Data

Mounting hole: 1.2 mm

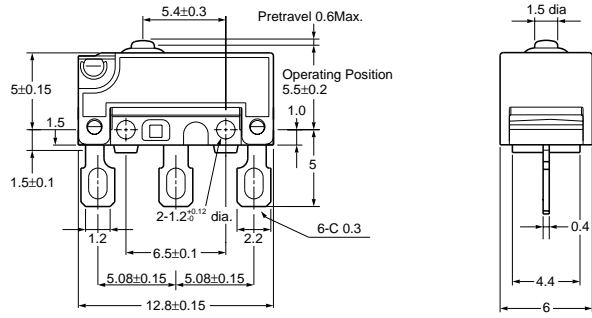

Mounting hole: 2.3 mm

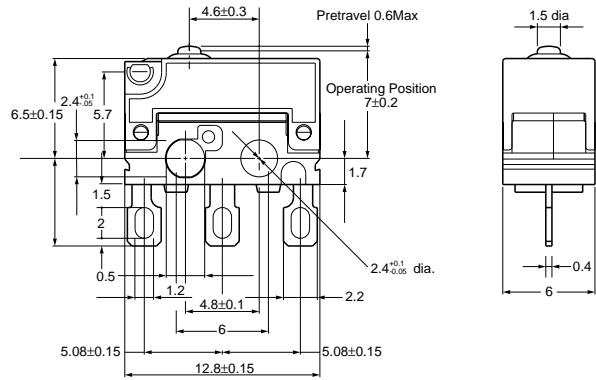

Remarks: Dimensions of the actuator type are the same as corresponding PC board terminal types.

2. Immersion protected type

2-(1) Bottom wire leads type

Pin plunger

CAD Data

Mounting hole: 1.2 mm

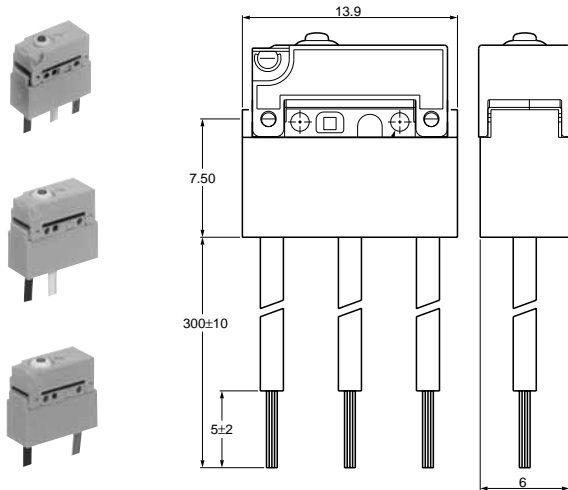

Thickness of the lead wire: 0.3 mm²
 UL/CSA approved type: AWG22
 Color of the lead wire:
 COM ...Black
 N.C. ...Red
 N.O. ...White

Mounting hole: 2.3 mm

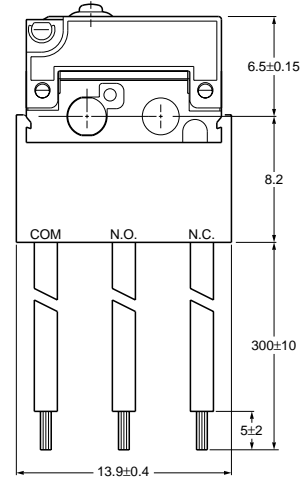

Thickness of the lead wire: 0.3 mm²
 UL/CSA approved type: AWG22
 Color of the lead wire:
 COM ...Black
 N.C.Red
 N.O. ...White

Remarks: 1. As for M1.2 type, other dimensions are the same as those of corresponding PC board terminal types.
 As for M2.3 type, other dimensions are the same as those of corresponding solder terminal types.
 2. Dimensions of the actuator type are the same as corresponding PC board terminal types.



Discontinued: Wire leads type with agency standard
 Last time buy: August 31, 2012

ABJ1,2,3,4,5

Leaf lever
 Mounting hole: 3 mm

mm General tolerance: ± 0.25

CAD Data

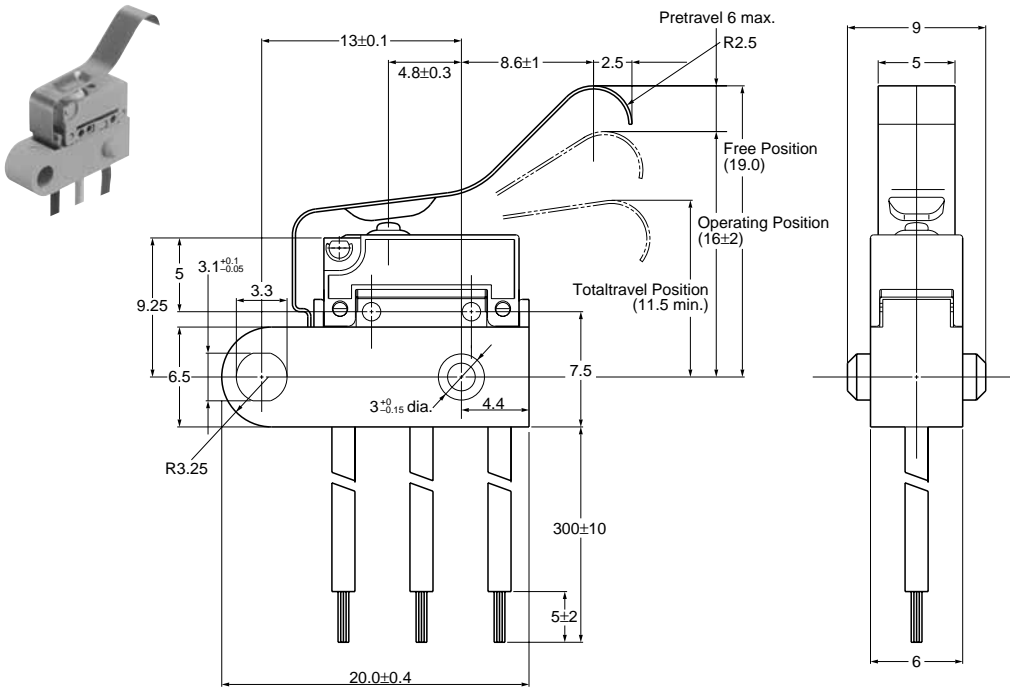

Pretravel, Max. mm		6.0
Movement differential, Max. mm		1.0
Overtravel, Min mm		2.5
Operating position	Distance from mounting hole, mm	16.0±2.0

2-(2) Side wire leads type
 Fixed pin type
 Right side pin type
 Right wire leads type

CAD Data

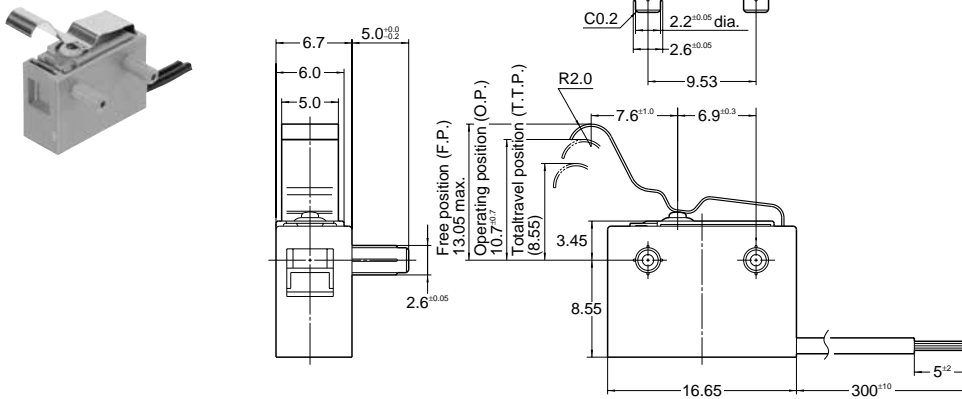

Pretravel, Max. mm		2.6
Movement differential, Max. mm		0.5
Overtravel, Min mm		1.4
Operating position	Distance from mounting hole, mm	10.7±0.7

ABJ1,2,3,4,5



Discontinued: Wire leads type with agency standard
Last time buy: August 31, 2012

Right side pin type
 Left wire leads type

mm General tolerance: ± 0.25

CAD Data

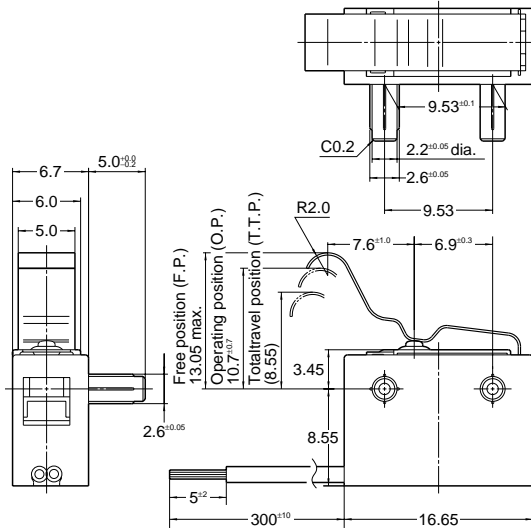

Pretravel, Max. mm		2.6
Movement differential, Max. mm		0.5
Overtravel, Min mm		1.4
Operating position	Distance from mounting hole, mm	10.7 \pm 0.7

Left side pin type
 Right wire leads type

CAD Data

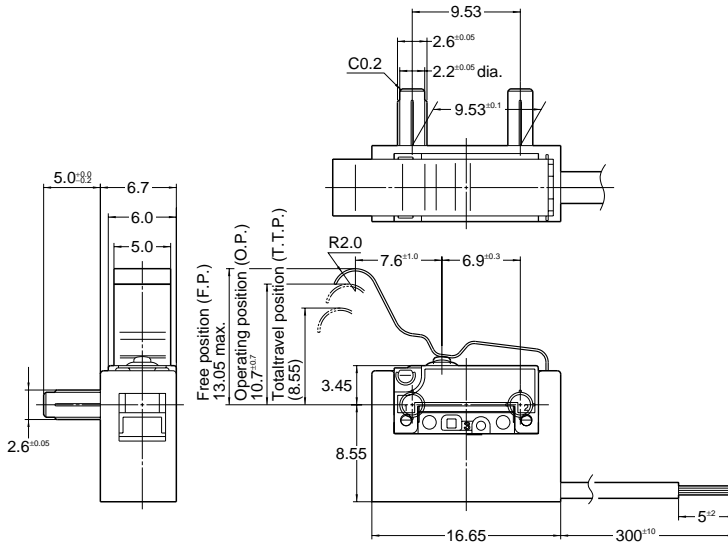
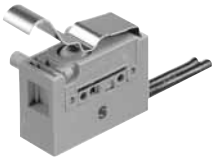

Pretravel, Max. mm		2.6
Movement differential, Max. mm		0.5
Overtravel, Min mm		1.4
Operating position	Distance from mounting hole, mm	10.7 \pm 0.7

Left side pin type
 Left wire leads type

CAD Data

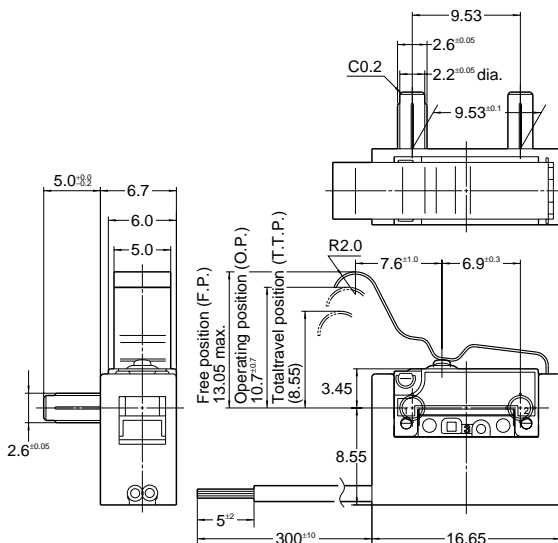

Pretravel, Max. mm		2.6
Movement differential, Max. mm		0.5
Overtravel, Min mm		1.4
Operating position	Distance from mounting hole, mm	10.7 \pm 0.7



Discontinued: Wire leads type with agency standard
 Last time buy: August 31, 2012

ABJ1,2,3,4,5

Mounting hole 3mm type

mm General tolerance: ± 0.25

CAD Data

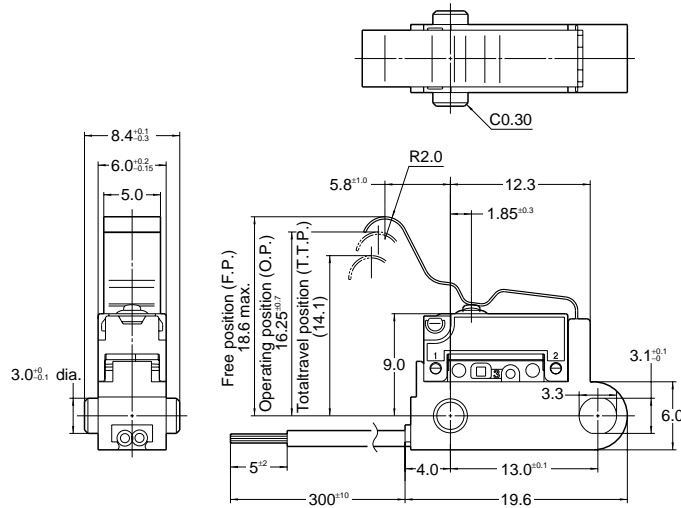

Pretravel, Max. mm		2.6
Movement differential, Max. mm		0.5
Overtravel, Min mm		1.4
Operating position	Distance from mounting hole, mm	16.25 \pm 0.7

3. Immersion protected type (Bottom wire leads type) Long stroke type

Mounting hole: 2.3 mm

CAD Data

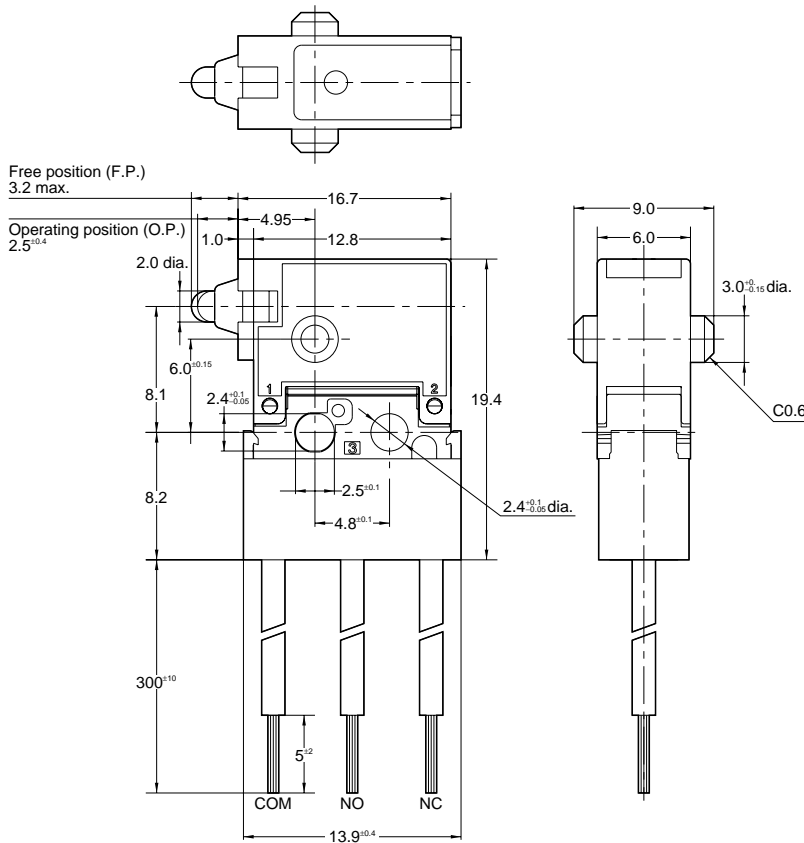

Movement differential, Max. mm		0.5
Overtravel, Min mm		2.0
Operating position		2.5 \pm 0.4

Компания «Океан Электроники» предлагает заключение долгосрочных отношений при поставках импортных электронных компонентов на взаимовыгодных условиях!

Наши преимущества:

- Поставка оригинальных импортных электронных компонентов напрямую с производств Америки, Европы и Азии, а так же с крупнейших складов мира;
- Широкая линейка поставок активных и пассивных импортных электронных компонентов (более 30 млн. наименований);
- Поставка сложных, дефицитных, либо снятых с производства позиций;
- Оперативные сроки поставки под заказ (от 5 рабочих дней);
- Экспресс доставка в любую точку России;
- Помощь Конструкторского Отдела и консультации квалифицированных инженеров;
- Техническая поддержка проекта, помощь в подборе аналогов, поставка прототипов;
- Поставка электронных компонентов под контролем ВП;
- Система менеджмента качества сертифицирована по Международному стандарту ISO 9001;
- При необходимости вся продукция военного и аэрокосмического назначения проходит испытания и сертификацию в лаборатории (по согласованию с заказчиком);
- Поставка специализированных компонентов военного и аэрокосмического уровня качества (Xilinx, Altera, Analog Devices, Intersil, Interpoint, Microsemi, Actel, Aeroflex, Peregrine, VPT, Syfer, Eurofarad, Texas Instruments, MS Kennedy, Miteq, Cobham, E2V, MA-COM, Hittite, Mini-Circuits, General Dynamics и др.);

Компания «Океан Электроники» является официальным дистрибьютором и эксклюзивным представителем в России одного из крупнейших производителей разъемов военного и аэрокосмического назначения «JONHON», а так же официальным дистрибьютором и эксклюзивным представителем в России производителя высокотехнологичных и надежных решений для передачи СВЧ сигналов «FORSTAR».



JONHON

«JONHON» (основан в 1970 г.)

Разъемы специального, военного и аэрокосмического назначения:

(Применяются в военной, авиационной, аэрокосмической, морской, железнодорожной, горно- и нефтедобывающей отраслях промышленности)

«FORSTAR» (основан в 1998 г.)

ВЧ соединители, коаксиальные кабели, кабельные сборки и микроволновые компоненты:

(Применяются в телекоммуникациях гражданского и специального назначения, в средствах связи, РЛС, а так же военной, авиационной и аэрокосмической отраслях промышленности).



Телефон: 8 (812) 309-75-97 (многоканальный)

Факс: 8 (812) 320-03-32

Электронная почта: ocean@oceanchips.ru

Web: <http://oceanchips.ru/>

Адрес: 198099, г. Санкт-Петербург, ул. Калинина, д. 2, корп. 4, лит. А