

ZL8101

Adaptive Digital DC/DC PWM Controller with Auto Compensation

FN7832  
Rev 1.00  
July 13, 2012

The ZL8101 is a digital PWM controller with auto compensation that is designed to work with either the ZL1505 MOSFET driver IC, ISL6611 Phase Doubler IC, or DrMOS type devices. Current sharing allows multiple devices to be connected in parallel to source loads with very high current demands. Adaptive performance optimization algorithms improve power conversion efficiency across the entire load range. Zilker Labs Digital-DC™ technology enables a blend of power conversion performance and power management features.

The ZL8101 is designed to be a flexible building block for DC power and can be easily adapted to designs ranging from a single-phase power supply operating from a 4.5V input to a multi-phase supply operating from a 12V input. The ZL8101 eliminates the need for complicated power supply managers as well as numerous external discrete components.

Most operating features can be configured by simple pin-strap/resistor selection or through the SMBus™ serial interface. The ZL8101 uses the PMBus™ protocol for communication with a host controller and the Digital-DC bus for communication between other Zilker Labs devices.

**Features**

- Efficient Synchronous Buck Controller
- Adaptive Performance Optimization Algorithms
- ±1% Output Voltage Accuracy
- Auto Compensation
- Snapshot™ Parametric Capture
- I<sup>2</sup>C/SMBus Interface, PMBus Compatible
- Internal Non-Volatile Memory (NVM)
- Tri-State PWM Gate Outputs
- Compatible with Industry Standard DrMOS Devices
- Compatible with Intersil ISL6611 Phase Doubler
- Synchronized External Driver Control

**Applications**

- Servers/Storage Equipment
- Telecom/Datacom Equipment
- Power Supplies (Memory, DSP, ASIC, FPGA)

**Related Literature**

- [AN2033](#) “Zilker Labs PMBus Command Set - DDC Products”
- [AN2034](#) “Configuring Current Sharing on the ZL2004 and ZL2006”
- [AN2010](#) “Thermal and Layout Guidelines for Digital-DC™ Products”

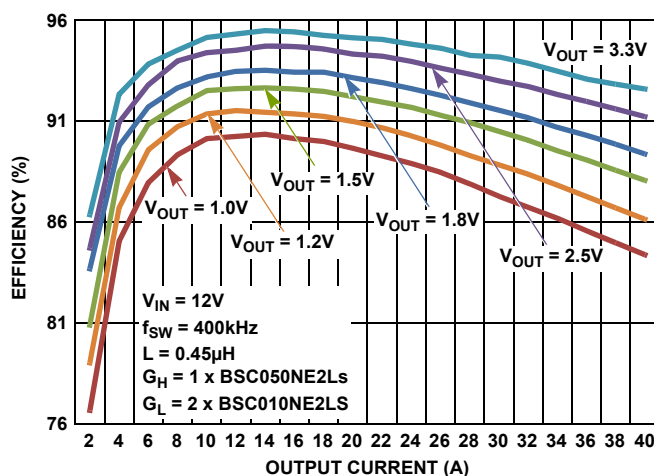
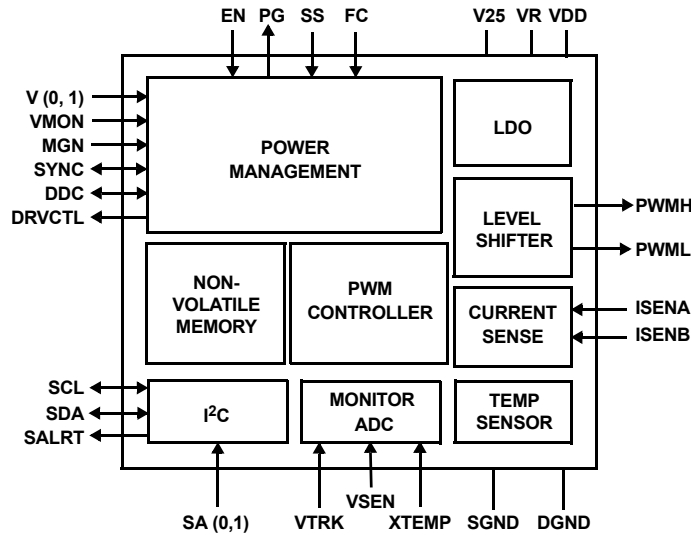

FIGURE 1. EFFICIENCY vs LOAD CURRENT

## Block Diagram



## Ordering Information

PART NUMBER (Notes 1, 2)	PART MARKING	TEMP. RANGE (°C)	PACK METHOD	PACKAGE	PKG. DWG. #
ZL8101ALAFT	8101	-40 to +85	Tape and Reel 6k	32 Ld QFN	L32.5x5G
ZL8101ALAFTK	8101	-40 to +85	Tape and Reel 1k	32 Ld QFN	L32.5x5G
ZL8101ALAF	8101	-40 to +85	Bulk	32 Ld QFN	L32.5x5G

**NOTES:**

- These Intersil Pb-free plastic packaged products employ special Pb-free material sets, molding compounds/die attach materials, and 100% matte tin plate plus anneal (e3 termination finish, which is RoHS compliant and compatible with both SnPb and Pb-free soldering operations). Intersil Pb-free products are MSL classified at Pb-free peak reflow temperatures that meet or exceed the Pb-free requirements of IPC/JEDEC J STD-020.
- For Moisture Sensitivity Level (MSL), please see device information page for [ZL8101](#). For more information on MSL please see techbrief [TB363](#).

## ZL Types

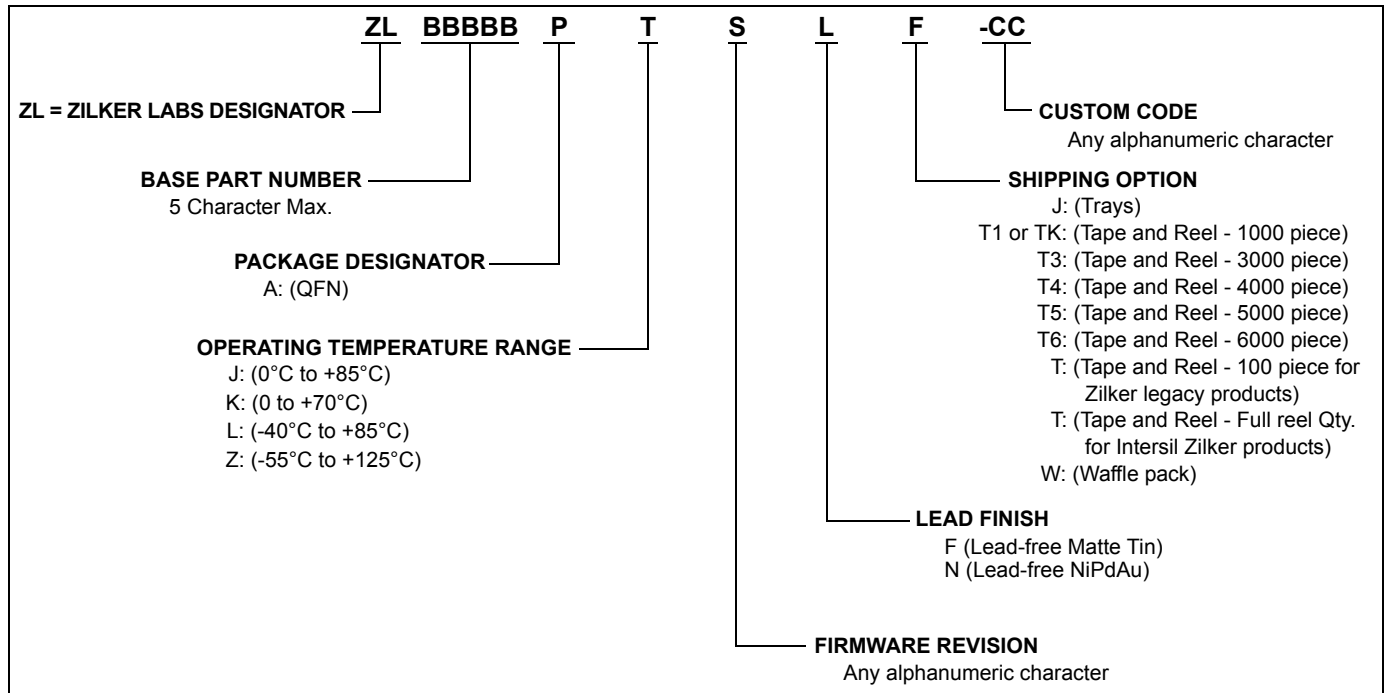

## Pin Configuration

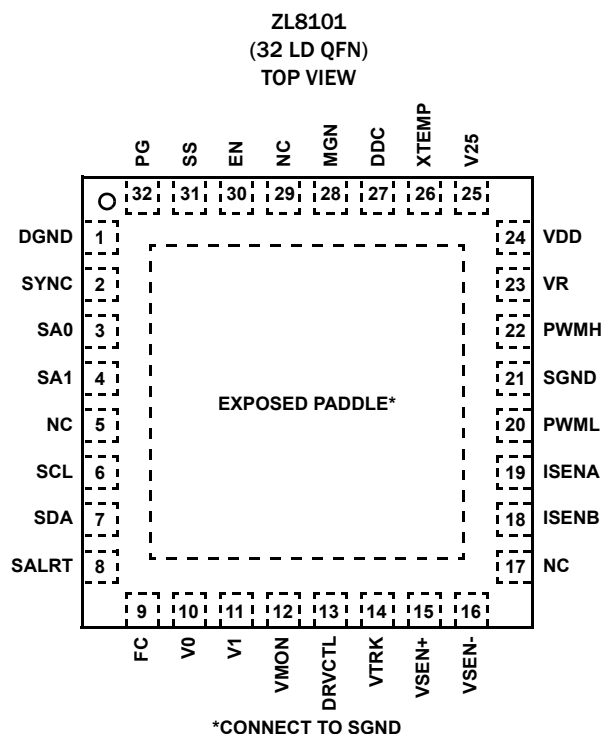

## Pin Descriptions

PIN	LABEL	TYPE (Note 3)	DESCRIPTION
1	DGND	PWR	Digital ground. Connect to low impedance contiguous ground plane.
2	SYNC	I/O, M (Note 4)	Clock synchronization input. Used to set the frequency of the internal switch clock, to sync to an external clock or to output internal clock.
3	SA0	I, M	Serial address select pins. Used to assign a unique address for each individual device or to enable certain management features.
4	SA1		
5	NC		No Connect. Leave pin open.
6	SCL	I/O	Serial clock. Connect to external host and/or to other ZL devices.
7	SDA	I/O	Serial data. Connect to external host and/or to other ZL devices.
8	SALRT	O	Serial alert. Connect to external host if desired.
9	FC	I	Auto compensation configuration pin. Used to set up auto compensation.
10	V0	I, M	Output voltage selection pins. Used to set $V_{OUT}$ set-point and $V_{OUT}$ max.
11	V1		
12	VMON	I, M	External voltage monitoring (can be used for external driver bias monitoring for Power-Good).
13	DRVCTL	O	External driver enable control output.
14	VTRK	I	Tracking sense input. Used to track an external voltage source.
15	VSEN+	I	Differential Output voltage sense feedback. Connect to positive output regulation point.
16	VSEN-	I	Differential Output voltage sense feedback. Connect to negative output regulation point.
17	NC		No Connect. Leave pin open.
18	ISENB	I	Differential voltage input for current sensing.
19	ISENA	I	Differential voltage input for current sensing. High voltage (DCR).

## Pin Descriptions (Continued)

PIN	LABEL	TYPE (Note 3)	DESCRIPTION
20	PWML	O	PWM Gate low signal.
21	SGND	PWR	Connect to low impedance ground plane. Internal connection to SGND.
22	PWMH	O	PWM Gate High signal.
23	VR	PWR	Internal 5V Reference.
24	VDD (Note 5)	PWR	Supply voltage.
25	V25	PWR	Internal 2.5V reference used to power internal circuitry.
26	XTEMP	I	External temperature sensor input. Connect to external 2N3904 (Base Emitter junction).
27	DDC	I	Single wire DDC bus (Current sharing, inter device communication).
28	MGN	I	V <sub>OUT</sub> margin control.
29	NC		No Connect. Leave pin open.
30	EN	I	Enable. Active signal enables PWM switching.
31	SS	I, M	Soft-start delay and ramp select. Sets the delay from when EN is asserted until the output voltage starts to ramp and the ramp time.
32	PG	O	Power-Good output.
PD	SGND	PWR	Exposed thermal pad. Connect to low impedance ground plane. Internal connection to SGND.

### NOTES:

3. I = Input, O = Output, PWR = Power or Ground. M = Multi-mode pins (refer to "Multi-mode Pins" on page 12).
4. The SYNC pin can be used as a logic pin, a clock input or a clock output.
5. The V<sub>DD</sub> pin voltage is used to measure V<sub>IN</sub> as part of the Pre-Bias calculation and Loop Gain calculation used for current sharing ramps.

# Table of Contents

<b>Absolute Maximum Ratings</b> .....	<b>6</b>
<b>Thermal Information</b> .....	<b>6</b>
<b>Recommended Operating Conditions</b> .....	<b>6</b>
<b>Electrical Specifications</b> .....	<b>6</b>
<b>Typical Application Circuit</b> .....	<b>11</b>
<b>ZL8101 Overview</b> .....	<b>11</b>
Digital-DC Architecture .....	11
Power Conversion Overview .....	12
Power Management Overview .....	12
Multi-mode Pins .....	12
<b>Power Conversion Functional Description</b> .....	<b>13</b>
Internal Bias Regulators and Input Supply Connections .....	13
Output Voltage Selection .....	13
Start-up Procedure .....	15
Soft-start Delay and Ramp Times .....	15
Power-Good .....	16
Switching Frequency and PLL .....	16
Power Train Component Selection .....	18
Current Limit Threshold Selection .....	20
Loop Compensation .....	21
Non-linear Response (NLR) Settings .....	22
Efficiency Optimized Driver Dead-time Control .....	22
Adaptive Diode Emulation .....	24
<b>Power Management Functional Description</b> .....	<b>24</b>
Input Undervoltage Lockout .....	24
Output Overvoltage Protection .....	24
Output Pre-Bias Protection .....	24
Minimum Duty Cycle .....	24
Output Overcurrent Protection .....	25
Thermal Overload Protection .....	25
Voltage Tracking .....	26
Tracking with Autocomp Enabled .....	27
Current Sharing and Tracking .....	27
Configuring Tracking Groups .....	27
Voltage Margining .....	28
External Voltage Monitoring .....	28
I2C/SMBus Communications .....	28
I2C/SMBus Device Address Selection .....	28
Digital-DC Bus .....	30
Phase Spreading .....	30
Output Sequencing .....	30
Fault Spreading .....	31
Active Current Sharing .....	31
Turn-On/Off Ramp Behavior .....	32
Current Share Fault Behavior .....	32
Phase Adding/Dropping .....	32
Monitoring Via I2C/SMBus .....	32
Temperature Monitoring Using the XTEMP Pin .....	33
Snapshot™ Parameter Capture .....	33
Non-Volatile Memory and Device Security Features .....	33
Configuration Files .....	34
Programmable Gain Amplifier Bias Current .....	34
<b>Revision History</b> .....	<b>35</b>
<b>Products</b> .....	<b>35</b>
<b>Package Outline Drawing</b> .....	<b>36</b>

**Absolute Maximum Ratings** (Note 6)

DC Supply Voltage for VDD Pin	-0.3V to 17V
Logic I/O Voltage for DDC, EN, FC, MGN, PG, SA(0,1), SALRT, SCL, SDA, SS, SYNC, VMON, V(0,1) Pins	-0.3V to 6.5V
Analog Input Voltages for VSEN+, VSEN-, VTRK, XTEMP Pins	-0.3V to 6.5V
Analog Input Voltages for ISENA, ISENB Pins	-1.5V to 6.5V
MOSFET Drive Reference for VR Pin	-0.3V to 6.5V
Logic Reference for V25 Pin	-0.3V to 3V
Ground Voltage Differential (V <sub>DGND</sub> -V <sub>SGND</sub> ) for DGND, SGND Pins	-0.3V to +0.3V
ESD Rating	
Human Body Model (Tested per JESD22-A114F)	2000V
Machine Model (Tested per JESD22-A115C)	200V
Latch Up	Tested per JESD-78

**Thermal Information**

Thermal Resistance (Typical)	$\theta_{JA}$ (°C/W)	$\theta_{JC}$ (°C/W)
32 Ld QFN Package (Notes 7, 8)	35	5
Operating Junction Temperature Range	-40°C to +125°C	
Junction Temperature	-55°C to +150°C	
Storage Temperature Range	-55°C to +150°C	
Pb-Free Reflow Profile	see link below	
	<a href="http://www.intersil.com/pbfree/Pb-FreeReflow.asp">http://www.intersil.com/pbfree/Pb-FreeReflow.asp</a>	

**Recommended Operating Conditions**

Input Supply Voltage Range	4.5V to 14V
Output Voltage Range (Inductor Sensing) (Note 9)	0.54V to 4V

**CAUTION:** Do not operate at or near the maximum ratings listed for extended periods of time. Exposure to such conditions may adversely impact product reliability and result in failures not covered by warranty.

**NOTES:**

- Voltage measured with respect to SGND.
- $\theta_{JA}$  is measured in free air with the component mounted on a high effective thermal conductivity test board with "direct attach" features. See Tech Brief TB379.
- For  $\theta_{JC}$ , the "case temp" location is the center of the exposed metal pad on the package underside.
- Includes margin limits.

**Electrical Specifications**  $V_{DD} = 12V$ ,  $T_A = -40^\circ C$  to  $+85^\circ C$ , unless otherwise specified. Typical values are at  $T_A = +25^\circ C$ . **Boldface limits apply over the operating temperature range,  $-40^\circ C$  to  $+85^\circ C$ .**

PARAMETER	CONDITIONS	MIN (Note 10)	TYP	MAX (Note 10)	UNIT
<b>INPUT AND SUPPLY CHARACTERISTICS</b>					
I <sub>DD</sub> Supply Current at f <sub>SW</sub> = 200kHz	GH no load, GL no load, MISC_CONFIG[7] = 1		16	<b>30</b>	mA
I <sub>DD</sub> Supply Current at f <sub>SW</sub> = 1.4MHz			25	<b>50</b>	mA
I <sub>DD</sub> S Shutdown Current	EN = 0V, No I <sup>2</sup> C/SMBus activity		6.5	<b>8</b>	mA
VR Reference Output Voltage	V <sub>DD</sub> > 6V	<b>4.5</b>	5.2	<b>5.7</b>	V
V25 Reference Output Voltage	V <sub>R</sub> > 3V	<b>2.25</b>	2.5	<b>2.75</b>	V
<b>OUTPUT CHARACTERISTICS</b>					
Output Voltage Adjustment Range (Note 11)		<b>0.6</b>		<b>3.6</b>	V
Output Voltage Set-point Resolution	Set using resistors		10		mV
	Set using I <sup>2</sup> C/SMBus		±0.025		% FS (Note 12)
Output Voltage Accuracy (Note 13)	Includes line, load, temp	<b>-1</b>		<b>1</b>	%
VSEN Input Bias Current	VSEN = 4V		80	<b>150</b>	µA
Current Sense Differential Input Voltage (V <sub>OUT</sub> Referenced)	V <sub>ISENA</sub> - V <sub>ISENB</sub>	<b>-50</b>		<b>50</b>	mV
Current Sense Input Bias Current (V <sub>OUT</sub> Referenced, V <sub>OUT</sub> ≤ 3.6V)	ISENA	<b>-50</b>		<b>50</b>	nA
	ISENB	<b>-75</b>		<b>75</b>	µA
Soft-start Delay Duration Range	Set using SS pin or resistor	<b>2</b>		<b>20</b>	ms
	Set using I <sup>2</sup> C/SMBus	<b>0.002</b>		<b>500</b>	s
Soft-start Delay Duration Accuracy	Turn-on delay (precise mode) (Notes 14, 15)		±0.25		ms
	Turn-on delay (normal mode) (Note 16)		-1/+5		ms
	Turn-off delay (Note 16)		-1/+5		ms

**Electrical Specifications**  $V_{DD} = 12V$ ,  $T_A = -40^\circ C$  to  $+85^\circ C$ , unless otherwise specified. Typical values are at  $T_A = +25^\circ C$ . **Boldface limits apply over the operating temperature range,  $-40^\circ C$  to  $+85^\circ C$ .** (Continued)

PARAMETER	CONDITIONS	MIN (Note 10)	TYP	MAX (Note 10)	UNIT
Soft-start Ramp Duration Range	Set using SS pin or resistor	<b>2</b>		<b>20</b>	ms
	Set using I <sup>2</sup> C	<b>0</b>		<b>200</b>	ms
Soft-start Ramp Duration Accuracy			100		μs
<b>LOGIC INPUT/OUTPUT CHARACTERISTICS</b>					
Logic Input Bias Current	EN, PG, SCL, SDA, SALRT pins	<b>-250</b>		<b>250</b>	nA
MGN Input Bias Current		<b>-1</b>		<b>1</b>	mA
Logic Input Low, V <sub>IL</sub>				<b>0.8</b>	V
Logic Input OPEN (N/C)	Multi-mode logic pins		1.4		V
Logic Input High, V <sub>IH</sub>		<b>2.0</b>			V
Logic Output Low, V <sub>OL</sub>	I <sub>OL</sub> ≤ 4mA			<b>0.4</b>	V
Logic Output High, V <sub>OH</sub>	I <sub>OH</sub> ≥ -2mA	<b>2.25</b>			V
<b>PWM OUTPUTS (PWMH, PWML)</b>					
PWM Output Voltage Low Threshold	I <sub>LOAD</sub> = ±500μA (Note 20) Sinking			100	mV
PWN Output Voltage High Threshold		<b>4.7</b>			V
<b>EXTERNAL DRIVER CONTROL (DRVCTL)</b>					
HW_EN to DRVCTL Delay (t <sub>dED</sub> )	Turn-on		100	350	μs
3S_Delay	Turn-off		0.1	2	ms
t <sub>dOFF</sub>	Turn-off		0.1	0.5	ms
<b>OSCILLATOR AND SWITCHING CHARACTERISTICS</b>					
Switching Frequency Range		<b>200</b>		<b>1400</b>	kHz
Switching Frequency Set-point Accuracy		<b>-5</b>		<b>5</b>	%
Maximum PWM Duty Cycle	Factory default, decreases with frequency	<b>95</b>			%
Minimum SYNC Pulse Width		<b>150</b>			ns
Input Clock Frequency Drift Tolerance	External clock source	<b>-13</b>		<b>13</b>	%
<b>TRACKING</b>					
VTRK Input Bias Current	VTRK = 4.0V		110	<b>200</b>	μA
VTRK Tracking Ramp Accuracy	100% Tracking, V <sub>OUT</sub> - VTRK (During Ramps)	<b>-100</b>		<b>+100</b>	mV
VTRK Regulation Accuracy	100% Tracking, V <sub>OUT</sub> - VTRK (Steady State)		1.5%		%
<b>FAULT PROTECTION CHARACTERISTICS</b>					
UVLO Threshold Range	Configurable via I <sup>2</sup> C/SMBus	<b>2.85</b>		<b>16</b>	V
UVLO Set-point Accuracy		<b>-150</b>		<b>150</b>	mV
UVLO Hysteresis	Factory default		3		%
	Configurable via I <sup>2</sup> C/SMBus	<b>0</b>		<b>100</b>	%
UVLO Delay				<b>2.5</b>	μs
Power-Good V <sub>OUT</sub> Low Threshold	Factory default		90		% V <sub>OUT</sub>
Power-Good V <sub>OUT</sub> High Threshold	Factory default		115		% V <sub>OUT</sub>
Power-Good V <sub>OUT</sub> Hysteresis	Factory default		5		%

**Electrical Specifications**  $V_{DD} = 12V$ ,  $T_A = -40^{\circ}C$  to  $+85^{\circ}C$ , unless otherwise specified. Typical values are at  $T_A = +25^{\circ}C$ . **Boldface limits apply over the operating temperature range,  $-40^{\circ}C$  to  $+85^{\circ}C$ . (Continued)**

PARAMETER	CONDITIONS	MIN (Note 10)	TYP	MAX (Note 10)	UNIT
Power-good Delay	Using pin-strap or resistor (Note 17)	<b>2</b>		<b>20</b>	ms
	Configurable via I <sup>2</sup> C/SMBus	<b>0</b>		<b>500</b>	s
VSEN Undervoltage Threshold	Factory default		85		% V <sub>OUT</sub>
	Configurable via I <sup>2</sup> C/SMBus	<b>0</b>		<b>110</b>	% V <sub>OUT</sub>
VSEN Overvoltage Threshold	Factory default		115		% V <sub>OUT</sub>
	Configurable via I <sup>2</sup> C/SMBus	<b>0</b>		<b>115</b>	% V <sub>OUT</sub>
VSEN Undervoltage Hysteresis			5		% V <sub>OUT</sub>
VSEN Undervoltage/Overvoltage Fault Response Time	Factory default		16		μs
	Configurable via I <sup>2</sup> C/SMBus	<b>5</b>		<b>60</b>	μs
Current Limit Set-point Accuracy (V <sub>OUT</sub> Referenced)			±10		% FS (Note 18)
Current Limit Protection Delay	Factory default		5		t <sub>SW</sub> (Note 19)
	Configurable via I <sup>2</sup> C/SMBus	<b>1</b>		<b>32</b>	t <sub>SW</sub> (Note 19)
Temperature Compensation of Current Limit Protection Threshold	Factory default		4400		ppm/°C
	Configurable via I <sup>2</sup> C/SMBus	<b>100</b>		<b>12700</b>	ppm/°C
Thermal Protection Threshold (Junction Temperature)	Factory default		125		°C
	Configurable via I <sup>2</sup> C/SMBus	<b>-40</b>		<b>125</b>	°C
Thermal Protection Hysteresis			15		°C

## NOTES:

10. Compliance to datasheet limits is assured by one or more methods: production test, characterization and/or design.
11. Set point adjustment range does not include margin limits.
12. Percentage of Full Scale (FS) with temperature compensation applied.
13. V<sub>OUT</sub> set-point measured at the termination of the VSEN+ and VSEN- sense points.
14. The device requires approximately 2ms following an enable signal and prior to ramping its output. The delay accuracy will vary by ±0.25ms around the 2ms minimum delay value.
15. Precise ramp timing mode is only valid when using EN pin to enable the device rather than PMBus enable.
16. The devices may require up to a 4ms delay following an assertion of the enable signal (normal mode) or following the de-assertion of the enable signal.
17. Factory default Power-good delay is set to the same value as the soft-start ramp time.
18. Percentage of Full Scale (FS) with temperature compensation applied.
19. t<sub>SW</sub> = 1/f<sub>SW</sub>, where f<sub>SW</sub> is the switching frequency.
20. Outputs are Tri-State when disabled.



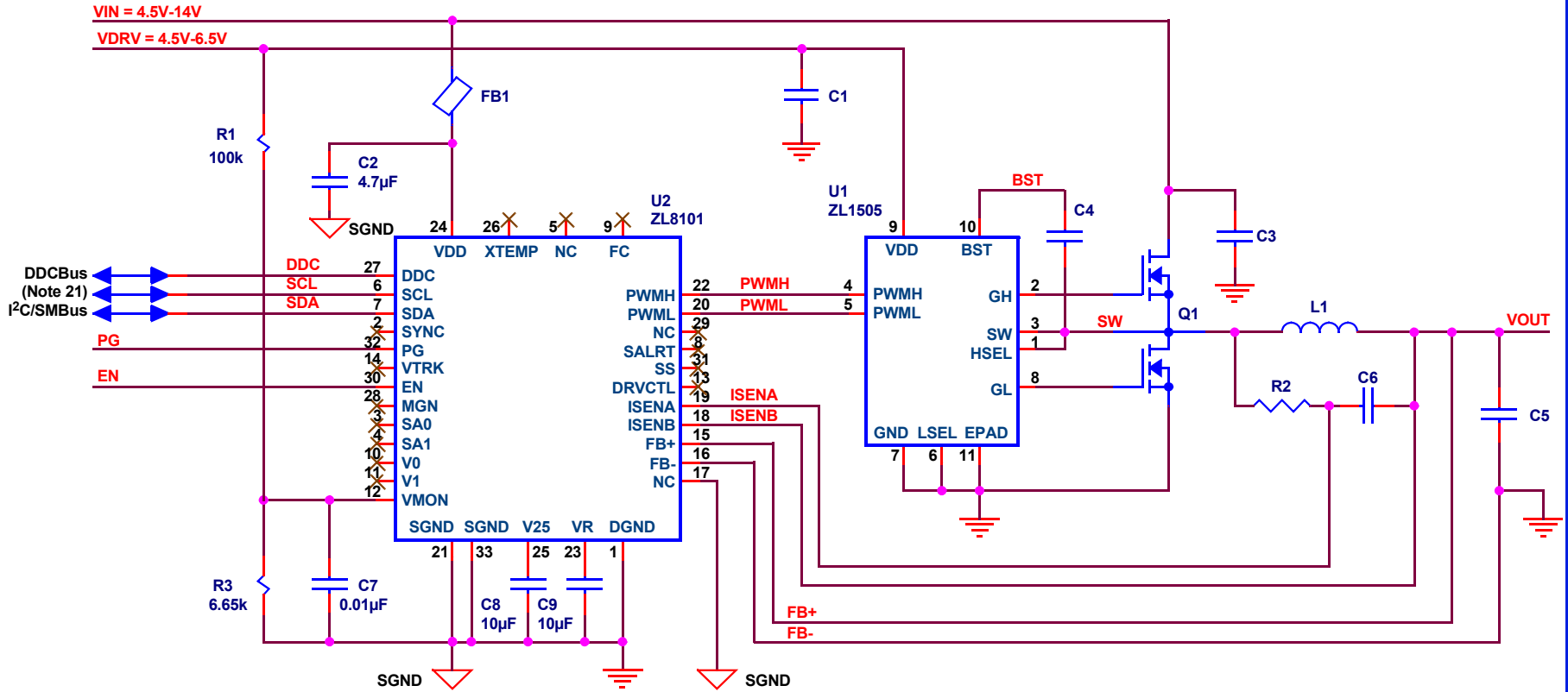

FIGURE 2. EXAMPLE DESIGN USING ZL8101 AND ZL1505 DRIVER

NOTE:

21. The DDC bus requires a pull-up resistor. The resistance will vary based on the capacitive loading of the bus (and on the number of devices connected). The 10k default value, assuming a maximum of 100pF per device, provides the necessary 1µs pull-up rise time. Please refer to the "Digital-DC Bus" section on page 30 for more information.

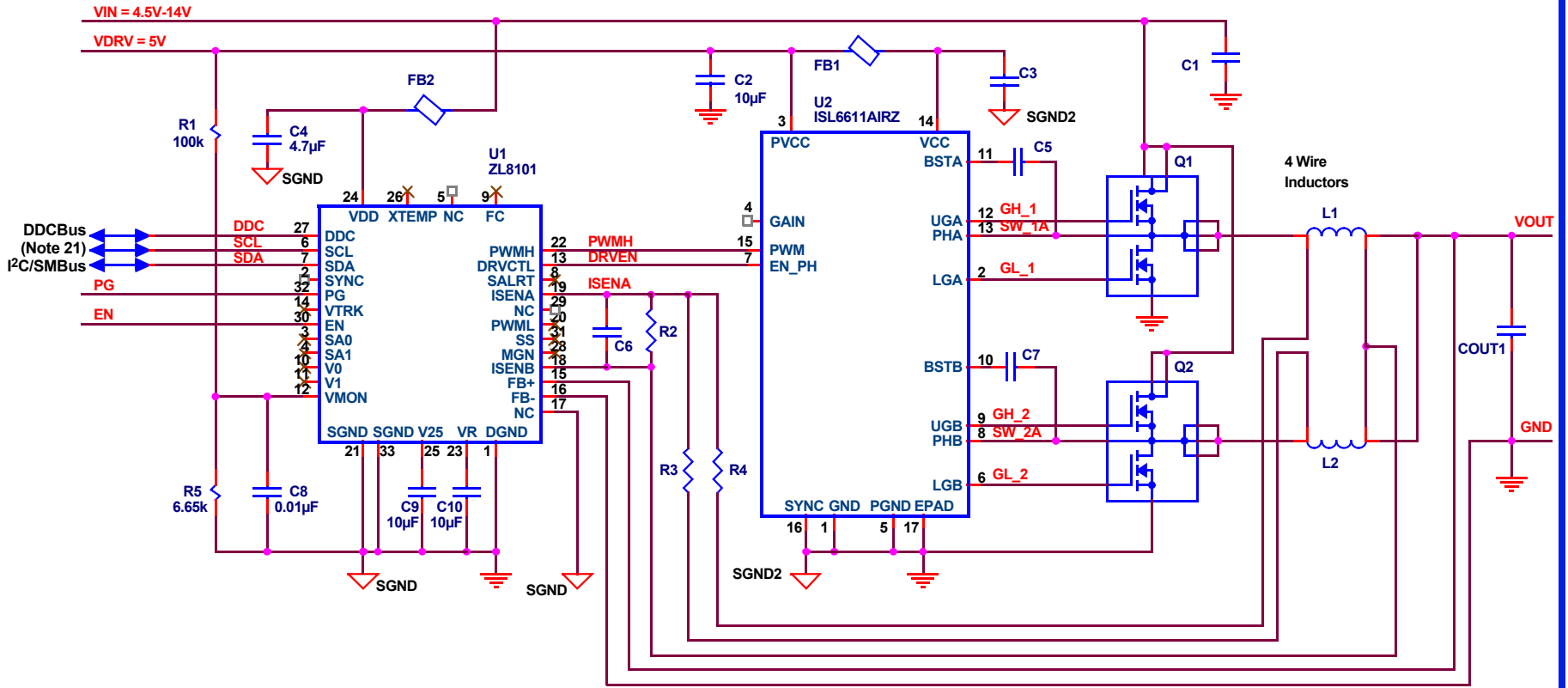

FIGURE 3. EXAMPLE DESIGN USING ZL8101 AND ISL6611 PHASE DOUBLER

## Typical Application Circuit

Figure 2 represents a typical application circuit for single phase applications using a ZL1505 driver. Other power stages like DrMOS devices can be substituted for the ZL1505 and output FET's.

Figure 3 represents a typical application circuit for 2-phase designs using a ISL6611 phase doubler IC.

## ZL8101 Overview

### Digital-DC Architecture

The ZL8101 is an innovative mixed-signal power conversion and power management IC based on Zilker Labs' patented Digital-DC technology that provides an integrated, high performance step-down converter for a wide variety of power supply applications.

Today's embedded power systems are typically designed for optimal efficiency at maximum load, reducing the peak thermal stress by limiting the total thermal dissipation inside the system. Unfortunately, many of these systems are often operated at load levels far below the peak where the power system has been optimized, resulting in reduced efficiency. While this may not cause thermal stress to occur, it does contribute to higher electricity usage and results in higher overall system operating costs.

Zilker Labs' efficiency-adaptive ZL8101 DC-DC controller helps mitigate this scenario by enabling the power converter to automatically change their operating state to increase efficiency and overall performance.

Its unique digital PWM loop utilizes an innovative mixed signal topology to enable precise control of the power conversion

process with no software required, resulting in a very flexible device that is also easy to use. An extensive set of power management functions is fully integrated and can be configured using simple pin connections or via the I<sup>2</sup>C/SMBus hardware interface using standard PMBus commands. The user configuration can be saved in an on-chip non-volatile memory (NVM), allowing ultimate flexibility.

Once enabled, the ZL8101 is immediately ready to regulate power and perform power management tasks with no programming required. The ZL8101 can be configured by simply connecting its pins according to the tables provided in this document. Advanced configuration options and real-time configuration changes are available via the I<sup>2</sup>C/SMBus interface if desired, and continuous monitoring of multiple operating parameters is possible with minimal interaction from a host controller. Integrated sub-regulation circuitry enables single supply operation from any supply between 4.5V and 14V with no secondary bias supplies needed.

Zilker Labs provides a comprehensive set of application notes to assist with power supply design and simulation. An evaluation board is also available to help the user become familiar with the device. This board can be evaluated as a stand-alone platform using pin configuration settings. Additionally, a Windows™-based GUI is provided to enable full configuration and monitoring capability via the I<sup>2</sup>C/SMBus interface using an available computer and the included USB cable.

Please refer to [www.intersil.com](http://www.intersil.com) for access to the most up-to-date documentation or call your local Intersil sales office to order an evaluation kit.

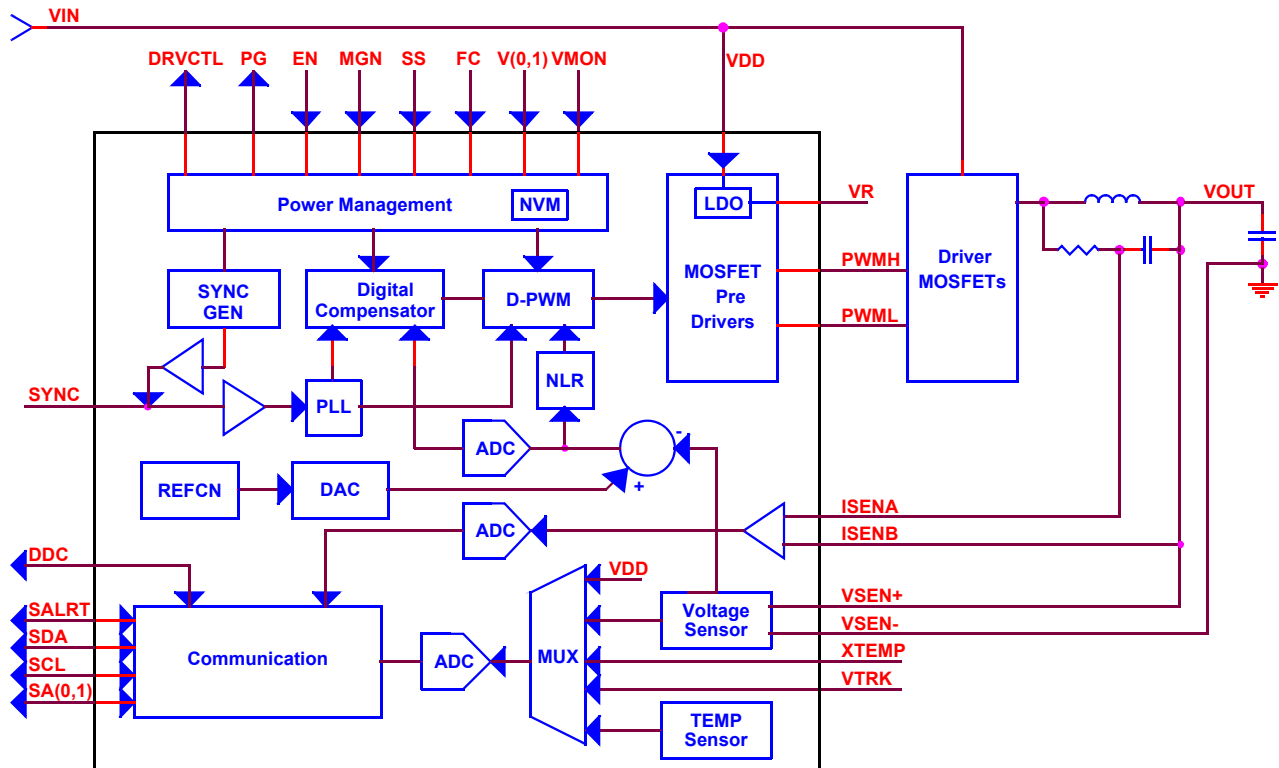

FIGURE 4. ZL8101 BLOCK DIAGRAM

## Power Conversion Overview

The ZL8101 operates as a voltage-mode, synchronous buck converter with a selectable constant frequency pulse width modulator (PWM) control scheme that uses an external driver, MOSFETs, capacitors, and an inductor to perform power conversion.

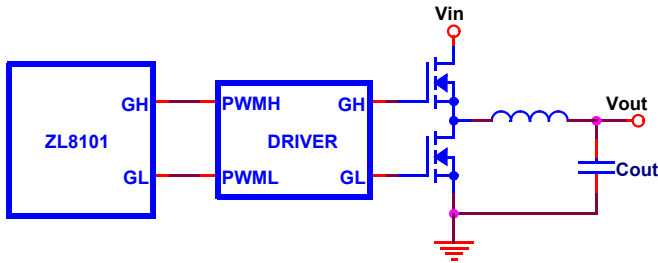

FIGURE 5. SYNCHRONOUS BUCK CONVERTER

Figure 5 illustrates the basic synchronous buck converter topology showing the primary power train components. This converter is also called a step-down converter, as the output voltage must always be lower than the input voltage.

## DUAL OUTPUT PWM

The ZL8101 provides a dual PWM signal for use with the ZL1505 driver and tri-state capable outputs for compatibility with single input drivers and DrMOS devices.

When using the ZL8101/ZL1505 driver combination, higher efficiency can be obtained by enabling the Zilker Labs Adaptive Dead Time Algorithm.

The ZL1505 is a driver with two PWM inputs. Using two PWM signals (PWMH and PWML) offers more options during fault event and pre-bias conditions. The ZL8101 has several features to improve the power conversion efficiency. A non-linear response (NLR) loop improves the response time and reduces the output deviation as a result of a load transient. The ZL8101 monitors the power converter's operating conditions and continuously adjusts the turn-on and turn-off timing of the high-side and low-side MOSFETs to optimize the overall efficiency of the power supply. Adaptive performance optimization algorithms such as dead-time control, diode emulation, and adaptive frequency are available to provide greater efficiency improvement. The ZL8101 can also be used with single-ended MOSFET drivers and DrMOS devices that require the PWMH output to Tri-State when Disabled.

The trade-offs for using this mode may include reduced efficiency and degraded pre-bias protection depending on the minimum pulse width requirement of the single input driver.

## TRI-STATE PWM OUTPUTS

Anytime the ZL8101 has power applied and PMBus or HW Enable is de-asserted, the PWMH and PWML CMOS outputs are Tri-States. The PWM outputs switch between 0 and the voltage on the VR pin (typically 5V). The ZL8101 PWM outputs are compatible with drivers who's inputs are pulled between 2.5V and 5.5V. The Tri-State function is always active, so no controls are provided. The ZL1505 driver contains integrated pull-down resistors that deactivate the tri-state function.

## DRIVER ENABLE CONTROL (DRVCTL)

The ZL8101 includes an output pin that can be used to control the enable pin of single input drivers and DrMOS devices. The DRVCTL pin is asserted High plus a small delay time ( $t_{dED}$ ) when HW Enable or PMBus Enable is asserted. The DRVCTL pin is de-asserted at the end of the fall time plus a delay ( $t_{dOFF}$ ). See Figure 6 for timing information.

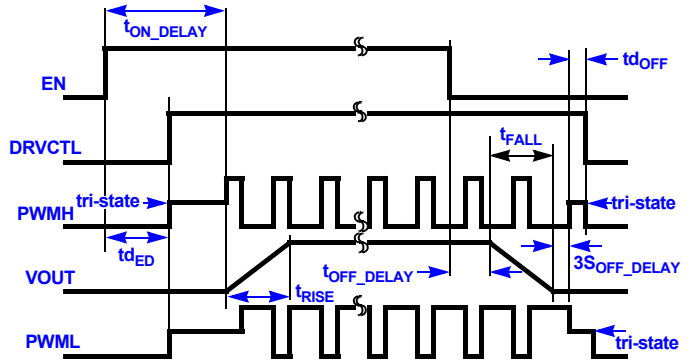

FIGURE 6. DRVCTL AND TRI-STATE BEHAVIOR

## Power Management Overview

The ZL8101 incorporates a wide range of configurable power management options that are simple to implement with no external components. The ZL8101 includes circuit protection features that continuously safeguard the device and load from damage due to unexpected system faults. The ZL8101 can continuously monitor input voltage, output voltage/current, internal temperature, and the temperature of an external thermal diode. A Power-good output signal is also included to enable power-on reset functionality for an external processor.

All power management functions can be configured using either pin configuration techniques (see Figure 7) or via the I<sup>2</sup>C/SMBus interface. Monitoring parameters can also be pre-configured to provide alerts for specific conditions. See Application Note [AN2033](#) for more details on SMBus monitoring.

## Multi-mode Pins

In order to simplify circuit design, the ZL8101 incorporates patented multi-mode pins that allow the user to easily configure many aspects of the device with no programming. Most power management features can be configured using these pins. The multi-mode pins can respond to four different connections as shown in Table 1. These pins are sampled when power is applied or by issuing a PMBus Restore command (See Application Note [AN2033](#)).

## PIN-STRAP SETTINGS

This is the simplest implementation method, as no external components are required. Using this method, each pin can take on one of three possible states: LOW, OPEN, or HIGH. These pins can be connected to the V25 pin for logic HIGH settings as this pin provides a regulated voltage higher than 2V. Using a single pin, one of three settings can be selected. Using two pins, one of nine settings can be selected.

**TABLE 1. MULTI-MODE PIN CONFIGURATION**

PIN TIED TO	VALUE
LOW (Logic LOW)	<0.8VDC
OPEN (N/C)	No connection
HIGH (Logic HIGH)	>2.0VDC
Resistor to SGND	Set by resistor value

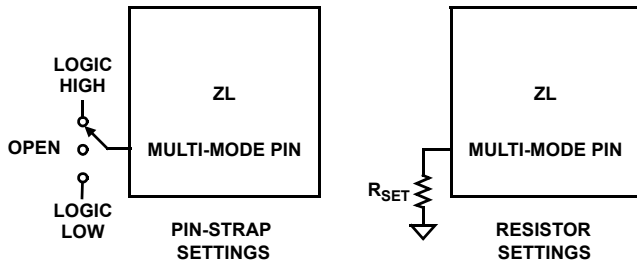

**FIGURE 7. PIN-STRAP AND RESISTOR SETTING EXAMPLES**

**RESISTOR SETTINGS**

This method allows a greater range of adjustability when connecting a finite value resistor (in a specified range) between the multi-mode pin and SGND. Standard 1% resistor values are used, and only every fourth E96 resistor value is used so the device can reliably recognize the value of resistance connected to the pin while eliminating the error associated with the resistor accuracy. Up to 31 unique selections are available using a single resistor.

**I<sup>2</sup>C/SMBUS METHOD**

Almost all ZL8101 functions can be configured via the I<sup>2</sup>C/SMBus interface using standard PMBus commands. Any value that has been configured using the pin-strap or resistor setting methods can also be re-configured and/or verified via the I<sup>2</sup>C/SMBus. See Application Note [AN2033](#) for more details.

The SMBus device address and VOUT\_MAX are the only parameters that must be set by external pins. All other device parameters can be set via the I<sup>2</sup>C/SMBus. The device address is set using the SA0 and SA1 pins. VOUT\_MAX is set to 10% greater than the voltage set by the V0 and V1 pins.

**Power Conversion Functional Description**

**Internal Bias Regulators and Input Supply Connections**

The ZL8101 employs two internal low dropout (LDO) regulators to supply bias voltages for internal circuitry, allowing it to operate from a single input supply. The internal bias regulators are as follows:

- **VR:** The VR LDO provides a regulated 5V bias supply for the MOSFET pre-driver circuits. It is powered from the VDD pin. A 4.7 to 10µF filter capacitor is required at the VR pin. To ensure regulator stability, capacitors outside of this range must not be used.

- **V25:** The V25 LDO provides a regulated 2.5V bias supply for the main controller circuitry. It is powered from an internal 5V node. A 4.7 to 10µF filter capacitor is required at the V25 pin. To ensure regulator stability capacitors outside of this range must not be used.

When the input supply (VDD) is higher than 5.5V, the VR pin should not be connected to any other pins. It should only have a filter capacitor attached as shown in Figure 8. Due to the dropout voltage associated with the VR bias regulator, the VDD pin must be connected to the VR pin for designs operating from a supply below 5.5V. Figure 8 illustrates the required connections for both cases.

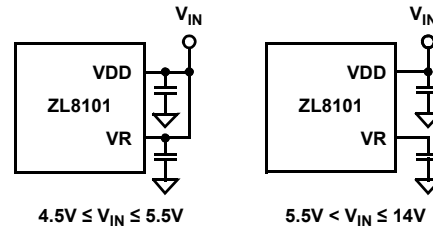

**FIGURE 8. INPUT SUPPLY CONNECTIONS**

**Note:** the internal bias regulators are not designed to be outputs for powering other circuitry. Do not attach external loads to any of these pins. The multi-mode pins may be connected to the V25 pin for logic HIGH settings.

**Output Voltage Selection**

**STANDARD MODE**

The output voltage may be set to any voltage between 0.6V and 3.6V provided that the input voltage is higher than the desired output voltage by an amount sufficient to prevent the device from exceeding its maximum duty cycle specification. Using the pin-strap method, V<sub>OUT</sub> can be set to any of nine standard voltages as shown in Table 2.

**TABLE 2. PIN-STRAP OUTPUT VOLTAGE SETTINGS**

		V0		
		LOW	OPEN	HIGH
V1	LOW	0.6V	0.8V	1.0V
	OPEN	1.2V	1.5V	1.8V
	HIGH	2.5V	3.3V	3.6V

The resistor setting method can be used to set the output voltage to levels not available in Table 2. Resistors R0 and R1 are selected to produce a specific voltage between 0.6V and 3.6V in 10mV steps. Resistor R1 provides a coarse setting and resistor R0 provides a fine adjustment, thus eliminating the additional errors associated with using two 1% resistors (this typically adds 1.4% error).

To set V<sub>OUT</sub> using resistors, follow the steps below to calculate an index value and then use Table 3 to select the resistor that corresponds to the calculated index value as follows:

1. Calculate Index1: Index1 = 4 × V<sub>OUT</sub> (V<sub>OUT</sub> in 10mV steps)
2. Round the result down to the nearest whole number.

3. Select the value of R1 from Table 3 using the Index1 rounded value from Step 2.
4. Calculate Index0: Index0 = 100 x V<sub>OUT</sub> - (25 x Index1)
5. Select the value of R0 from Table 3 using the Index0 value from Step 4.

**TABLE 3. RESISTORS FOR SETTING OUTPUT VOLTAGE**

INDEX	R0 OR R1 (kΩ)
0	10
1	11
2	12.1
3	13.3
4	14.7
5	16.2
6	17.8
7	19.6
8	21.5
9	23.7
10	26.1
11	28.7
12	31.6
13	34.8
14	38.3
15	42.2
16	46.4
17	51.1
18	56.2
19	61.9
20	68.1
21	75
22	82.5
23	90.9
24	100

Example from Figure 9: For V<sub>OUT</sub> = 1.33V,

Index1 = 4 x 1.33V = 5.32;

From Table 3, R1 = 16.2kΩ

Index0 = (100 x 1.33V) - (25 x 5) = 8;

From Table 3, R0 = 21.5kΩ

The output voltage can be determined from the R0 (Index0) and R1 (Index1) values using Equation 1:

$$V_{OUT} = \frac{\text{Index0} + (25 \times \text{Index1})}{100} \quad (\text{EQ. 1})$$

The output voltage may also be set to any value between 0.6V and 3.6V using the I<sup>2</sup>C interface. See Application Note [AN2033](#) for details.

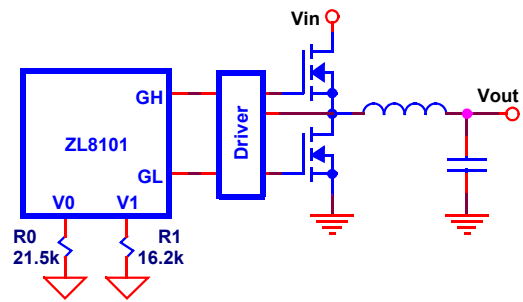

**FIGURE 9. OUTPUT VOLTAGE RESISTOR SETTING EXAMPLE**

### Single Resistor Output Voltage Setting Mode

Some applications desire the output voltage to be set using a single resistor. This can be accomplished using a resistor on the V1 pin while the V0 pin is tied to SGND. Table 4 lists the available output voltage settings with a single resistor. See Application Note [AN2033](#) for more details.

**TABLE 4.**

R <sub>V1</sub> (kΩ)	R <sub>V0</sub>	V <sub>OUT</sub>
10	Low	0.60
11	Low	0.65
12.1	Low	0.70
13.3	Low	0.75
14.7	Low	0.80
16.2	Low	0.85
17.8	Low	0.90
19.6	Low	0.95
21.5	Low	1.00
23.7	Low	1.05
26.1	Low	1.10
28.7	Low	1.15
31.6	Low	1.20
34.8	Low	1.25
38.3	Low	1.30
42.2	Low	1.40
46.4	Low	1.50
51.1	Low	1.60
56.2	Low	1.70
61.9	Low	1.80
68.1	Low	1.90
75.0	Low	2.00
82.5	Low	2.10
90.9	Low	2.20
100	Low	2.30

TABLE 4. (Continued)

$R_{V1}(k\Omega)$	$R_{V0}$	$V_{OUT}$
110	Low	2.50
121	Low	3.00
133	Low	3.30
147	Low	4.00
162	Low	5.00
178	Low	5.50

## Start-up Procedure

The ZL8101 follows a specific internal start-up procedure after power is applied to the VDD pin. Table 5 describes the start-up sequence.

If the device is to be synchronized to an external clock source, the clock frequency must be stable prior to asserting the EN pin. The device requires approximately 5ms to 10ms to check for specific values stored in its internal memory. If the user has stored values in memory, those values will be loaded. The device will then check the status of all multi-mode pins and load the values associated with the pin settings.

Once this process is completed, the device is ready to accept commands via the I<sup>2</sup>C/SMBus interface and the device is ready to be enabled. Once enabled, the device requires approximately 2ms before its output voltage may be allowed to start its ramp-up process. If a soft-start delay period less than 2ms has

been configured (using PMBus commands), the device will default to a 2ms delay period (with an accuracy of approximately  $\pm 0.25$ ms). If a delay period greater than 2ms is configured, the device will wait for the configured delay period prior to starting to ramp its output.

After the delay period has expired, the output will begin to ramp towards its target voltage according to the pre-configured soft-start ramp time that has been set using the SS pin.

## Soft-start Delay and Ramp Times

In some applications, it may be necessary to set a delay from when an enable signal is received until the output voltage starts to ramp to its target value. In addition, the designer may wish to precisely set the time required for  $V_{OUT}$  to ramp to its target value after the delay period has expired. These features may be used as part of an overall inrush current management strategy or to precisely control how fast a load IC is turned on. The ZL8101 gives the system designer several options for precisely and independently controlling both the delay and ramp time periods.

The soft-start delay period begins when the EN pin is asserted and ends when the delay time expires. The soft-start delay period is set using the SS pin.

The soft-start ramp timer enables a precisely controlled ramp to the nominal  $V_{OUT}$  value that begins once the delay period has expired. The ramp-up is guaranteed monotonic and its slope may be precisely set using the SS pin.

The soft-start delay and ramp times can be set to standard values according to Table 6.

TABLE 5. ZL8101 START-UP SEQUENCE

STEP #	STEP NAME	DESCRIPTION	TIME DURATION
1	Power Applied	Input voltage is applied to the ZL8101's VDD pin	Depends on input supply ramp time
2	Internal Memory Check	The device will check for values stored in its internal memory. This step is also performed after a Restore command.	Approx 5ms to 10ms (device will ignore an enable signal or PMBus traffic during this period)
3	Multi-mode Pin Check	The device loads values configured by the multi-mode pins.	
4	Device Ready	The device is ready to accept an enable signal.	-
5	Pre-ramp Delay	The device requires approximately 2ms following an enable signal and prior to ramping its output. Additional pre-ramp delay may be configured using the Delay pins.	Approximately 2ms

TABLE 6. SOFT-START RAMP SETTINGS

R <sub>SS</sub> (kΩ)	SS DELAY (ms)	SS RAMP (ms)	UVLO (V)
LOW	2	2	4.5
OPEN	5	5	
HIGH	10	10	
10	2	2	4.5
11		5	
12.1		10	
13.3	5	2	
14.7		5	
16.2		10	
17.8		20	
19.6	10	2	
21.5		5	
23.7		10	
26.1		20	
28.7	20	2	
31.6		5	
34.8		10	
38.3		20	
42.2	2	2	10.8
46.4		5	
51.1		10	
56.2		20	
61.9	5	2	
68.1		5	
75		10	
82.5		20	
90.9	10	2	
100		5	
110		10	
121		20	
133	20	2	
147		5	
162		10	
178		20	

Note that when Auto Compensation is enabled, the minimum TON\_DELAY is 5ms.

The value of this resistor is measured upon start-up or Restore and will not change if the resistor is varied after power has been applied to the ZL8101. See Figure 10 for typical connections using resistors.

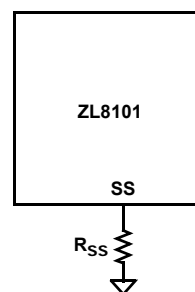

FIGURE 10. SS PIN RESISTOR CONNECTIONS

If the desired soft-start delay and ramp times are not one of the values listed in Table 6, the times can be set to a custom value via the I<sup>2</sup>C/SMBus interface. When the SS delay time is set to 0ms, the device will begin its ramp after the internal circuitry has initialized (~2ms). The soft-start ramp period may be set to values less than 2ms, however it is generally recommended to set the soft-start ramp to a value greater than 500μs to prevent inadvertent fault conditions due to excessive inrush current.

### Power-Good

The ZL8101 provides a Power-Good (PG) signal that indicates the output voltage is within a specified tolerance of its target level and no fault condition exists. By default, the PG pin will assert if the output is within -10%/+15% of the target voltage. These limits and the polarity of the pin may be changed via the I<sup>2</sup>C/SMBus interface. See Application Note [AN2033](#) for details.

A PG delay period is defined as the time from when all conditions within the ZL8101 for asserting PG are met, to when the PG pin is actually asserted. This feature is commonly used instead of using an external reset controller to control external digital logic. By default, the ZL8101 PG delay is set equal to the soft-start ramp time setting. Therefore, if the soft-start ramp time is set to 10ms, the PG delay will be set to 10ms. The PG delay may be set independently of the soft-start ramp using the I<sup>2</sup>C/SMBus as described in Application Note AN2033.

### Switching Frequency and PLL

The ZL8101 incorporates an internal phase-locked loop (PLL) to clock the internal circuitry. The PLL can be driven by an external clock source connected to the SYNC pin. When using the internal oscillator, the SYNC pin can be configured as a clock source for other Zilker Labs devices.

The SYNC pin is a unique pin that can perform multiple functions depending on how it is configured.



**CONFIGURATION A: SYNC OUTPUT**

When the SYNC pin is configured as an output, the device will run from its internal oscillator and will drive the resulting internal oscillator signal (preset to 400kHz) onto the SYNC pin so other devices can be synchronized to it. The SYNC pin will not be checked for an incoming clock signal while in this mode. This mode is only available using the I<sup>2</sup>C/SMBus as described in Application Note AN2033.

**CONFIGURATION B: SYNC INPUT**

When the SYNC pin is configured as an input, the device will automatically check for a clock signal on the SYNC pin each time EN is asserted. The ZL8101's oscillator will then synchronize with the rising edge of the external clock. The internal clock must be configured to the nearest available frequency to the external clock, to minimize output perturbations if the external clock is lost.

The incoming clock signal must be in the range of 200kHz to 1.4MHz and must be stable when the enable pin is asserted. The clock signal must also exhibit the necessary performance requirements (see the "Electrical Specifications" table beginning on page 6). In the event of a loss of the external clock signal, the output voltage may show transient over/undershoot.

If this happens, the ZL8101 will automatically switch to its internal oscillator and switch at a frequency close to the previous incoming frequency. This mode is only available using the

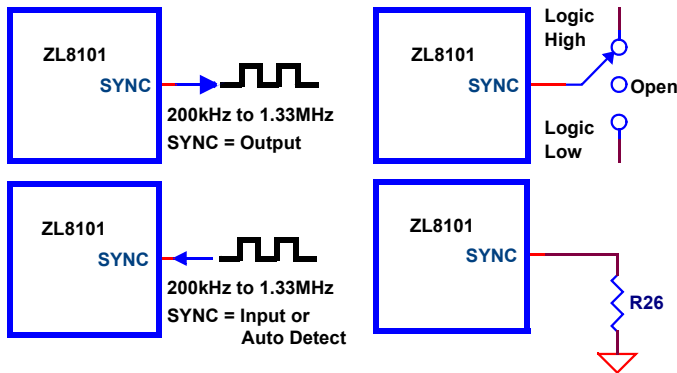

FIGURE 11. SYNC PIN CONFIGURATIONS

I<sup>2</sup>C/SMBus as described in Application Note AN2033.

**SYNC AUTO DETECT**

When the SYNC pin is configured in auto detect mode, the device will automatically check for a clock signal on the SYNC pin after enable is asserted.

If a clock signal is present, The ZL8101's oscillator will then synchronize the rising edge of the external clock.

If no incoming clock signal is present, the ZL8101 will configure the switching frequency according to the state of the SYNC pin as listed in Table 7. In this mode, the ZL8101 will only read the SYNC pin connection during the start-up sequence. Changes to

SYNC pin connections will not affect f<sub>SW</sub> until the power (VDD) is cycled off and on.

TABLE 7. SWITCHING FREQUENCY SELECTION

SYNC PIN	FREQUENCY
LOW	200kHz
OPEN	400kHz
HIGH	1MHz
Resistor	See Table 8

If the user desires to configure other frequencies not listed in Table 7, the switching frequency can also be set to any value between 200kHz and 1.33MHz using the I<sup>2</sup>C/SMBus interface. The available frequencies below 1.4MHz are defined by f<sub>SW</sub> = 8MHz/N, where 6 ≤ N ≤ 40. See Application Note AN2033 for details.

If a value other than f<sub>SW</sub> = 8MHz/N is entered using a PMBus command, the internal circuitry will select the switching frequency value using N as a whole number to achieve a value close to the entered value. For example, if 810kHz is entered, the device will select 800kHz (N = 10).

TABLE 8. R<sub>SYNC</sub> RESISTOR VALUES

R <sub>SYNC</sub> (kΩ)	f <sub>sw</sub> (kHz)
10	200
11	222
12.1	242
13.3	267
14.7	296
16.2	320
17.8	364
19.6	400
21.5	421
23.7	471
26.1	533
28.7	571
31.6	615
34.8	727
38.3	800
46.4	889
51.1	1000
56.2	1143
68.1	1333

When multiple Zilker Labs devices are used together, connecting the SYNC pins together will force all devices to synchronize with each other. One of the devices must be configured as a Sync source and the remaining devices must be configured as a Sync input. The I<sup>2</sup>C/SMBus must be used to configure the Sync Pin.

**Note:** The switching frequency read back using the appropriate PMBus command will differ slightly from the selected values in Table 8. The difference is due to hardware quantization.

## Power Train Component Selection

The ZL8101 is a synchronous buck converter that uses external Driver, MOSFETs, inductor and capacitors to perform the power conversion process. The proper selection of the external components is critical for optimized performance.

To select the appropriate external components for the desired performance goals, the power supply requirements listed in Table 9 must be known.

**TABLE 9. POWER SUPPLY REQUIREMENTS**

PARAMETER	RANGE	EXAMPLE VALUE
Input voltage ( $V_{IN}$ )	4.5V to 14.0V	12V
Output voltage ( $V_{OUT}$ )	0.6V to 3.6V	1.2V
Output current ( $I_{OUT}$ )	0A to ~25A	20A
Output voltage ripple ( $V_{ORIP}$ )	< 3% of $V_{OUT}$	1% of $V_{OUT}$
Output load step ( $I_{OSTEP}$ )	< $I_O$	50% of $I_O$
Output load step rate	-	10A/ $\mu$ s
Output deviation due to load step	-	$\pm$ 50mV
Maximum PCB temp.	+120 °C	+85 °C
Desired efficiency	-	85%
Other considerations	Various	Optimize for small size

## DESIGN GOAL TRADE-OFFS

The design of the buck power stage requires several compromises among size, efficiency, and cost. The inductor core loss increases with frequency, so there is a trade-off between a small output filter made possible by a higher switching frequency and getting better power supply efficiency. Size can be decreased by increasing the switching frequency at the expense of efficiency. Cost can be minimized by using through-hole inductors and capacitors; however these components are physically large.

To start the design, select a switching frequency based on Table 10. This frequency is a starting point and may be adjusted as the design progresses.

**TABLE 10. CIRCUIT DESIGN CONSIDERATIONS**

FREQUENCY RANGE	EFFICIENCY	CIRCUIT SIZE
200kHz to 400kHz	Highest	Larger
400kHz to 800kHz	Moderate	Smaller
800kHz to 1.4MHz	Lower	Smallest

## DRIVER SELECTION

The ZL8101 requires an external driver, the recommended 2-input companion driver is the ZL1505 with integrated 30V bootstrap Schottky diode. The ZL1505 has independent PWMH

and PWML inputs to take advantage of the dynamic dead-time control on the ZL8101.

The ZL8101 can be used with other driver devices, like the ISL6611 Phase Doubler Driver and several DrMOS type drivers. Please check with Intersil if you are not sure about compatibility.

## INDUCTOR SELECTION

The output inductor selection process must include several trade-offs. A high inductance value will result in a low ripple current ( $I_{opp}$ ), which will reduce output capacitance and produce a low output ripple voltage, but may also compromise output transient load performance. Therefore, a balance must be struck between output ripple and optimal load transient performance. A good starting point is to select the output inductor ripple equal to the expected load transient step magnitude ( $I_{ostep}$ ):

$$I_{opp} = I_{ostep} \quad (\text{EQ. 2})$$

Now the output inductance can be calculated using Equation 3, where  $V_{INM}$  is the maximum input voltage:

$$L_{OUT} = \frac{V_{OUT} \times \left(1 - \frac{V_{OUT}}{V_{INM}}\right)}{f_{sw} \times I_{opp}} \quad (\text{EQ. 3})$$

The average inductor current is equal to the maximum output current. The peak inductor current ( $I_{Lpk}$ ) is calculated using Equation 4 where  $I_{OUT}$  is the maximum output current:

$$I_{Lpk} = I_{OUT} + \frac{I_{opp}}{2} \quad (\text{EQ. 4})$$

Select an inductor rated for the average DC current with a peak current rating above the peak current computed in Equation 4.

In overcurrent or short-circuit conditions, the inductor may have currents greater than 2X the normal maximum rated output current. It is desirable to use an inductor that still provides some inductance to protect the load and the MOSFETs from damaging currents in this situation.

Once an inductor is selected, the DCR and core losses in the inductor are calculated. Use the DCR specified in the inductor manufacturer's datasheet.

$$P_{LDCR} = DCR \times I_{Lrms}^2 \quad (\text{EQ. 5})$$

$I_{Lrms}$  is given by Equation 6:

$$I_{Lrms} = \sqrt{I_{OUT}^2 + \frac{(I_{opp})^2}{12}} \quad (\text{EQ. 6})$$

where  $I_{OUT}$  is the maximum output current. Next, calculate the core loss of the selected inductor. Since this calculation is specific to each inductor and manufacturer, refer to the chosen inductor datasheet. Add the core loss and the ESR loss and compare the total loss to the maximum power dissipation recommendation in the inductor datasheet.

## OUTPUT CAPACITOR SELECTION

Several trade-offs must also be considered when selecting an output capacitor. Low ESR values are needed to have a small output deviation during transient load steps ( $V_{osag}$ ) and low output voltage ripple ( $V_{orip}$ ). However, capacitors with low ESR, such as semi-stable (X5R and X7R) dielectric ceramic capacitors, also have relatively low capacitance values. Many designs can use a combination of high capacitance devices and low ESR devices in parallel.

For high ripple currents, a low capacitance value can cause a significant amount of output voltage ripple. Likewise, in high transient load steps, a relatively large amount of capacitance is needed to minimize the output voltage deviation while the inductor current ramps up or down to the new steady state output current value.

As a starting point, apportion one-half of the output ripple voltage to the capacitor ESR and the other half to capacitance, as shown in Equations 7 and 8:

$$C_{OUT} = \frac{I_{opp}}{8 \times f_{sw} \times \frac{V_{orip}}{2}} \quad (\text{EQ. 7})$$

$$ESR = \frac{V_{orip}}{2 \times I_{opp}} \quad (\text{EQ. 8})$$

Use these values to make an initial capacitor selection, using a single capacitor or several capacitors in parallel.

After a capacitor has been selected, the resulting output voltage ripple can be calculated using Equation 9:

$$V_{orip} = I_{opp} \times ESR + \frac{I_{opp}}{8 \times f_{sw} \times C_{OUT}} \quad (\text{EQ. 9})$$

Because each part of this equation was made to be less than or equal to half of the allowed output ripple voltage, the  $V_{orip}$  should be less than the desired maximum output ripple.

## INPUT CAPACITOR

It is highly recommended that dedicated input capacitors be used in any point-of-load design, even when the supply is powered from a heavily filtered 5V or 12V “bulk” supply from an off-line power supply. This is because of the high RMS ripple current that is drawn by the buck converter topology. This ripple ( $I_{CINrms}$ ) can be determined from Equation 10:

$$I_{CINrms} = I_{OUT} \times \sqrt{D \times (1 - D)} \quad (\text{EQ. 10})$$

Without capacitive filtering near the power supply circuit, this current would flow through the supply bus and return planes, coupling noise into other system circuitry. The input capacitors should be rated at 1.2X the ripple current calculated above to avoid overheating of the capacitors due to the high ripple current, which can cause premature failure. Ceramic capacitors with X7R or X5R dielectric with low ESR and 1.1X the maximum expected input voltage are recommended.

## QL SELECTION

The bottom MOSFET should be selected primarily based on the device's  $r_{DS(ON)}$  and secondarily based on its gate charge. To choose QL, use Equation 11 and allow 2% to 5% of the output power to be dissipated in the  $r_{DS(ON)}$  of QL (lower output voltages and higher step-down ratios will be closer to 5%):

$$P_{QL} = 0.05 \times V_{OUT} \times I_{OUT} \quad (\text{EQ. 11})$$

Calculate the RMS current in QL as follows:

$$I_{botrms} = I_{Lrms} \times \sqrt{1 - D} \quad (\text{EQ. 12})$$

Calculate the desired maximum  $r_{DS(ON)}$  as follows:

$$R_{DS(ON)} = \frac{P_{QL}}{(I_{botrms})^2} \quad (\text{EQ. 13})$$

Note that the  $r_{DS(ON)}$  given in the manufacturer's datasheet is measured at +25 °C. The actual  $r_{DS(ON)}$  in the end-use application will be much higher. For example, a Vishay Si7114 MOSFET with a junction temperature of +125 °C has an  $r_{DS(ON)}$  that is 1.4 times higher than the value at +25 °C. Select a candidate MOSFET, and calculate the required gate drive current as follows:

$$I_g = f_{sw} \times Q_g \quad (\text{EQ. 14})$$

Keep in mind that the total allowed gate drive current for both QH and QL is 80mA.

MOSFETs with lower  $r_{DS(ON)}$  tend to have higher gate charge requirements, which increases the current and resulting power required to turn them on and off. Since the MOSFET gate drive circuits are integrated in the ZL1505, this power is dissipated in the ZL1505 according to Equation 15:

$$P_{QL} = f_{sw} \times Q_g \times V_{INM} \quad (\text{EQ. 15})$$

## QH SELECTION

In addition to the  $r_{DS(ON)}$  loss and gate charge loss, QH also has switching loss. The procedure to select QH is similar to the procedure for QL. First, assign 2% to 5% of the output power to be dissipated in the  $r_{DS(ON)}$  of QH using the Equation 11 for QL. As was done with QL, calculate the RMS current as follows:

$$I_{toprms} = I_{Lrms} \times \sqrt{D} \quad (\text{EQ. 16})$$

Calculate a starting  $r_{DS(ON)}$  as follows, in this example using 5%:

$$P_{QH} = 0.05 \times V_{OUT} \times I_{OUT} \quad (\text{EQ. 17})$$

$$R_{DS(ON)} = \frac{P_{QH}}{(I_{toprms})^2} \quad (\text{EQ. 18})$$

Select a MOSFET and calculate the resulting gate drive current. Verify that the combined gate drive current from QL and QH does not exceed 80mA.

Next, calculate the switching time using Equation 19:

$$t_{sw} = \frac{Q_g}{I_{gdr}} \quad (\text{EQ. 19})$$

where  $Q_g$  is the gate charge of the selected QH and  $I_{gdr}$  is the peak gate drive current available from the ZL1505.

Although the ZL1505 has a typical gate drive current of 3.2A, use the minimum guaranteed current of 2A for a conservative design. Using the calculated switching time, calculate the switching power loss in QH using Equation 20:

$$P_{swtop} = V_{INM} \times t_{sw} \times I_{OUT} \times f_{sw} \quad (\text{EQ. 20})$$

The total power dissipated by QH is given by Equation 21:

$$P_{QHtot} = P_{QH} + P_{swtop} \quad (\text{EQ. 21})$$

**MOSFET THERMAL CHECK**

Once the power dissipations for QH and QL have been calculated, the MOSFET’s junction temperature can be estimated. Using the junction-to-case thermal resistance ( $R_{th}$ ) given in the MOSFET manufacturer’s datasheet and the expected maximum printed circuit board temperature, calculate the junction temperature as shown in Equation 22:

$$T_{jmax} = T_{pcb} + (P_Q \times R_{th}) \quad (\text{EQ. 22})$$

**CURRENT SENSING COMPONENTS**

Once the current sense method has been selected (refer to “Current Limit Threshold Selection” on page 22), the components are selected as follows.

When using the inductor DCR sensing method, the user must also select an R/C network comprised of  $R_1$  and  $C_L$  (see Figure 12).

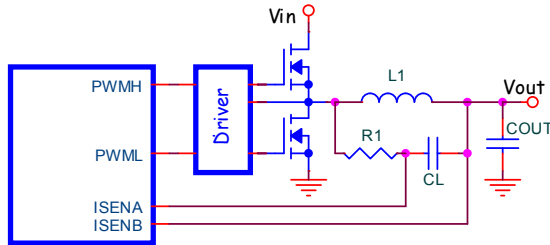

FIGURE 12. DCR CURRENT SENSING

For the voltage across  $C_L$  to reflect the voltage across the DCR of the inductor, the time constant of the inductor must match the time constant of the RC network. That is:

$$\tau_{RC} = \tau_{L/DCR} \quad (\text{EQ. 23})$$

$$R_1 \cdot C_L = \frac{L}{DCR}$$

For L, use the average of the nominal value and the minimum value. Include the effects of tolerance, DC Bias and switching frequency on the inductance when determining the minimum value of L. Use the typical value for DCR.

The value of  $R_1$  should be as small as feasible and no greater than  $5k\Omega$  for best signal-to-noise ratio. The designer should make sure the resistor package size is appropriate for the power dissipated and include this loss in efficiency calculations. In calculating the minimum value of  $R_1$ , the average voltage across  $C_L$  (which is the average  $I_{OUT}$  DCR product) is small and can be neglected. Therefore, the minimum value of  $R_1$  may be approximated by Equation 24:

$$R_{1-min} = \frac{D(V_{IN-max} - V_{OUT})^2 + (1 - D) \cdot V_{OUT}^2}{P_{R1pkg-max} \cdot \delta_p} \quad (\text{EQ. 24})$$

where  $P_{R1pkg-max}$  is the maximum power dissipation specification for the resistor package and  $\delta_p$  is the derating factor for the same parameter (e.g.:  $P_{R1pkg-max} = 0.0625W$  for 0603 package,  $\delta_p = 50\%$  @  $+85^\circ C$ ). Once  $R_{1-min}$  has been calculated, solve for the maximum value of  $C_L$  from Equation 25:

$$C_{L-max} = \frac{L}{R_{1-min} \cdot DCR} \quad (\text{EQ. 25})$$

and choose the next-lowest readily available value (e.g., for  $C_{L-max} = 1.86\mu F$ ,  $C_L = 1.5\mu F$  is a good choice). Then substitute the chosen value into the same equation and re-calculate the value of  $R_1$ . Choose the 1% resistor standard value closest to this re-calculated value of  $R_1$ . The error due to the mismatch of the two time constants is:

$$\epsilon_\tau = \left( 1 - \frac{R_1 \cdot C_L \cdot DCR}{L_{avg}} \right) \cdot 100\% \quad (\text{EQ. 26})$$

**Current Limit Threshold Selection**

It is recommended that the user include a current limiting mechanism in their design to protect the power supply from damage and prevent excessive current from being drawn from the input supply in the event that the output is shorted to ground or an overload condition is imposed on the output. Current limiting is accomplished by sensing the current through the circuit during a portion of the duty cycle.

Output current sensing can be accomplished by measuring the voltage across a series resistive sensing element according to Equation 27:

$$V_{LIM} = I_{LIM} \times R_{SENSE} \quad (\text{EQ. 27})$$

Where:

$I_{LIM}$  is the desired maximum current that should flow in the circuit

$R_{SENSE}$  is the resistance of the sensing element

$V_{LIM}$  is the voltage across the sensing element at the point the circuit should start limiting the output current.

The ZL8101 supports “lossless” current sensing, by measuring the voltage across a resistive element that is already present in the circuit. This eliminates additional efficiency losses incurred by devices that must use an additional series resistance in the circuit.

To set the current limit threshold, the user must first select a current sensing method. The ZL8101 incorporates inductor DC

resistance (DCR) sensing; Figure 12 shows a simplified schematic for DCR method.  $r_{DS(ON)}$  method is not supported.

Advanced ILIM pinstrapping options are not available for the ZL8101. However, all current limit and fault response options are available when using I<sup>2</sup>C/SMBus interface and configuration file.

The blanking time represents the time when no current measurement is taken. This is to avoid taking a reading just after a coincident switching edge (less accurate due to potential ringing). Blanking time is a configurable parameter.

ZL8101 provides an adjustable maximum full scale sensing range. The available ranges are 25mV, 35mV and 50mV using the I<sup>2</sup>C/SMBus interface or a configuration file. Table 11 lists the factory default value for the current limit function.

**TABLE 11. FACTORY DEFAULT ILIM CONFIGURATION**

CURRENT LIMITING CONFIGURATION	NUMBER OF VIOLATIONS ALLOWED	CURRENT LIMIT THRESHOLD $V_{LIM}$ (mV)	MAXIMUM CURRENT SENSING RANGE (mV)
Output-referenced, down-slope sensing (Inductor DCR sensing) Blanking time: 480ns	7	50	50

The user must select the voltage threshold (VLIM), the desired current limit threshold, and the resistance of the sensing element.

The current limit threshold must be set to a custom value via the I<sup>2</sup>C/SMBus interface. Please refer to Application Note [AN2033](#) for further details.

## Loop Compensation

The ZL8101 has an auto compensation feature that measures the characteristics of the power train and calculates the proper tap coefficients. Auto compensation is configured using the FC pin as shown in Table 12.

**TABLE 12. PIN #9 (FC) AUTO COMPENSATION MODE**

$R_{FC}$ (k $\Omega$ )	STORE VALUES	SINGLE/ REPEAT	PG ASSERT	AUTO COMP GAIN
LOW	Auto Comp Disabled			
OPEN	Not Stored	Single	After Auto Comp	100%
HIGH	Store in Flash	Single	After Auto Comp	

**TABLE 12. PIN #9 (FC) AUTO COMPENSATION MODE (Continued)**

$R_{FC}$ (k $\Omega$ )	STORE VALUES	SINGLE/ REPEAT	PG ASSERT	AUTO COMP GAIN
10	Not Stored	Single	After Auto Comp	100%
11	Store in Flash			
12.1	Not Stored	Repeat 1s	After Auto Comp	
13.3	Store in Flash			
14.7	Not Stored	Single	After PG Delay	
16.2	Store in Flash			
17.8	Not Stored	Repeat 1s	After PG Delay	
19.6	Store in Flash			
OPEN	Not Stored	Single	After Auto Comp	
HIGH/ 21.5	Store in Flash			
23.7	Not Stored	Repeat 1min	After PG Delay	
26.1	Store in Flash			
28.7	Not Stored	Single	After PG Delay	
31.6	Store in Flash			
34.8	Not Stored	Repeat 1min	After Auto Comp	
38.3	Store in Flash			
42.2	Not Stored	Single	After Auto Comp	
46.4	Store in Flash			
51.1	Not Stored	Repeat 1s	After PG Delay	
56.2	Store in Flash			
61.9	Not Stored	Single	After PG Delay	
68.1	Store in Flash			
75	Not Stored	Repeat 1s	After Auto Comp	
82.5	Store in Flash			
90.9	Not Stored	Single	After PG Delay	
100	Store in Flash			
110	Not Stored	Repeat 1min	After Auto Comp	
121	Store in Flash			
133	Not Stored	Single	After PG Delay	
147	Store in Flash			
162	Not Stored	Repeat 1min	After Auto Comp	
178	Store in Flash			



When auto compensation is enabled, the routine can be set to execute one time after ramp or periodically while regulating. Note that the Auto Compensation feature requires a minimum TON\_DELAY as described in "Soft-Start Delay and Ramp Times" on page 16.

If the device is configured to store auto comp values, the calculated compensation values will be saved in the Auto Comp Store and may be read back through the PID\_TAPS command. If repeat mode is enabled, the first Auto Comp results after the first ramp will be stored; the values calculated periodically are not stored in the Auto Comp Store. When compensation values are saved in the Auto Comp Store, the device will use those compensation values on subsequent ramps. In repeat mode, the latest Auto Comp results will always be used during operation. Stored Auto Comp results can only be cleared by disabling Auto Comp Store, which is not permitted while the output is enabled. However, sending the AUTOCOMP\_CONTROL command while enabled in Store mode will cause the next results to be stored, overwriting previously stored values. If auto compensation is disabled, the device will use the compensation parameters that are stored in the DEFAULT\_STORE or USER\_STORE.

If the PG Assert parameter is set to "Use PG Delay," PG will be asserted according to the POWER\_GOOD\_DELAY command. When Auto Comp is enabled, the user must not program a Power-Good Delay that will expire before the ramp is finished. If PG Assert is set to "After Auto Comp," PG will be asserted immediately after the first Auto Comp cycle completes (POWER\_GOOD\_DELAY will be ignored). The Auto Comp Gain control scales the Auto Comp results to allow a trade-off between transient response and steady-state duty cycle jitter. A setting of 100% will provide the fastest transient response while a setting of 10% will produce the lowest jitter. Note that if Auto Comp is enabled, for best results Vin must be stable before Auto Comp begins, as shown in Equation 28. The auto compensation function can also be configured via the AUTO\_COMP\_CONFIG command and controlled using the AUTO\_COMP\_CONTROL command over the I<sup>2</sup>C/SMBus interface. Please refer to Application Note AN2033 for further details.

$$\frac{\Delta V_{in}}{V_{inNom}} (\text{in}\%) \leq \frac{100\%}{1 + \frac{256 \cdot V_{out}}{V_{inNom}}} \quad (\text{EQ. 28})$$

## Non-linear Response (NLR) Settings

The ZL8101 incorporates a non-linear response (NLR) loop that decreases the response time and the output voltage deviation in the event of a sudden output load current step. The NLR loop incorporates a secondary error signal processing path that bypasses the primary error loop when the output begins to transition outside of the standard regulation limits. This scheme results in a higher equivalent loop bandwidth than what is possible using a traditional linear loop.

When a load current step function imposed on the output causes the output voltage to drop below the lower regulation limit, the NLR circuitry will force a positive correction signal that will turn on the upper MOSFET and quickly force the output to increase. Conversely, a negative load step (i.e., removing a large load current) will cause the NLR circuitry to force a negative correction signal that will turn on the lower MOSFET and quickly force the

output to decrease. The ZL8101 has been pre-configured with appropriate NLR settings that correspond to the loop compensation settings in Table 13.

## Efficiency Optimized Driver Dead-time Control

The ZL8101 utilizes a closed loop algorithm to optimize the dead-time applied between the gate drive signals for the top and bottom FETs. In a synchronous buck converter, the MOSFET drive circuitry must be designed such that the top and bottom MOSFETs are never in the conducting state at the same time. Potentially damaging currents flow in the circuit if both top and bottom MOSFETs are simultaneously on for periods of time exceeding a few nanoseconds. Conversely, long periods of time in which both MOSFETs are off reduce overall circuit efficiency by allowing current to flow in their parasitic body diodes.

It is therefore advantageous to minimize this dead-time to provide optimum circuit efficiency. In the first order model of a buck converter, the duty cycle is determined by Equation 29:

$$D \approx \frac{V_{OUT}}{V_{IN}} \quad (\text{EQ. 29})$$

However, non-idealities exist that cause the real duty cycle to extend beyond the ideal. Dead-time is one of those non-idealities that can be manipulated to improve efficiency. The ZL8101 has an internal algorithm that constantly adjusts dead-time non-overlap to minimize duty cycle, thus maximizing efficiency.

This circuit will null out dead-time differences due to component variation, temperature, and loading effects.

This algorithm is independent of application circuit parameters such as MOSFET type, gate driver delays, rise and fall times and circuit layout.

In addition, it does not require drive or MOSFET voltage or current waveform measurements.

TABLE 13. PIN-STRAP SETTINGS FOR LOOP COMPENSATION

NLR	$f_n$ RANGE	$f_{zesr}$ RANGE	FC PIN (k $\Omega$ )
Off	$f_{sw}/60 < f_n < f_{sw}/30$	$f_{zesr} > f_{sw}/10$	10
		$f_{sw}/10 > f_{zesr} > f_{sw}/30$	11
		$f_{sw}/30 > f_{zesr} > f_{sw}/60$	12.1
	$f_{sw}/120 < f_n < f_{sw}/60$	$f_{zesr} > f_{sw}/10$	13.3
		$f_{sw}/10 > f_{zesr} > f_{sw}/30$	14.7
		$f_{sw}/30 > f_{zesr} > f_{sw}/60$	16.2
	$f_{sw}/240 < f_n < f_{sw}/120$	$f_{zesr} > f_{sw}/10$	17.8
		$f_{sw}/10 > f_{zesr} > f_{sw}/30$	19.6
		$f_{sw}/30 > f_{zesr} > f_{sw}/60$	21.5
On	$f_{sw}/60 < f_n < f_{sw}/30$	$f_{zesr} > f_{sw}/10$	23.7
		$f_{sw}/10 > f_{zesr} > f_{sw}/30$	26.1
		$f_{sw}/30 > f_{zesr} > f_{sw}/60$	28.7
	$f_{sw}/120 < f_n < f_{sw}/60$	$f_{zesr} > f_{sw}/10$	31.6
		$f_{sw}/10 > f_{zesr} > f_{sw}/30$	34.8
		$f_{sw}/30 > f_{zesr} > f_{sw}/60$	38.3
	$f_{sw}/240 < f_n < f_{sw}/120$	$f_{zesr} > f_{sw}/10$	42.2
		$f_{sw}/10 > f_{zesr} > f_{sw}/30$	46.4
		$f_{sw}/30 > f_{zesr} > f_{sw}/60$	51.1

## Adaptive Diode Emulation

Most power converters use synchronous rectification to optimize efficiency over a wide range of input and output conditions. However, at light loads the synchronous MOSFET will typically sink current and introduce additional energy losses associated with higher peak inductor currents, resulting in reduced efficiency. Adaptive diode emulation mode turns off the low-side FET gate drive at low load currents to prevent the inductor current from going negative, reducing the energy losses and increasing overall efficiency. Diode emulation is available to single-phase devices only.

Note: the overall bandwidth of the device may be reduced when in diode emulation mode. It is recommended that diode emulation is disabled prior to applying significant load steps.

## Power Management Functional Description

### Input Undervoltage Lockout

The input undervoltage lockout (UVLO) prevents the ZL8101 from operating when the input falls below a preset threshold, indicating the input supply is out of its specified range. The UVLO threshold ( $V_{UVLO}$ ) can be set between 4.5V and 10.8V using the SS pin. The simplest implementation is to connect the SS pin as shown in Table 6.

The UVLO voltage can also be set to any value between 2.85V and 16V via the I<sup>2</sup>C/SMBus interface.

Once an input undervoltage fault condition occurs, the device can respond in a number of ways as follows:

1. Continue operating without interruption.
2. Continue operating for a given delay period, followed by shutdown if the fault still exists. The device will remain in shutdown until instructed to restart.
3. Initiate an immediate shutdown until the fault has been cleared. The user can select a specific number of retry attempts.

The default response from a UVLO fault is an immediate shutdown of the device. The device will continuously check for the presence of the fault condition. If the fault condition is no longer present, the ZL8101 will be re-enabled.

Please refer to Application Note [AN2033](#) for details on how to configure the UVLO threshold or to select specific UVLO fault response options via the I<sup>2</sup>C/SMBus interface.

### Output Overvoltage Protection

The ZL8101 offers an internal output overvoltage protection circuit that can be used to protect sensitive load circuitry from being subjected to a voltage higher than its prescribed limits. A hardware comparator is used to compare the actual output voltage (seen at the VSEN pin) to a threshold set to 15% higher than the target output voltage (the default setting). If the VSEN voltage exceeds this threshold, the PG pin will de-assert and the device can then respond in a number of ways as follows:

1. Initiate an immediate shutdown until the fault has been cleared. The user can select a specific number of retry attempts.
2. Turn off the high-side MOSFET and turn on the low-side MOSFET. The low-side MOSFET remains ON until the device attempts a restart.

The default response from an overvoltage fault is to immediately shut down. The device will continuously check for the presence of the fault condition, and when the fault condition no longer exists the device will be re-enabled.

For continuous overvoltage protection when operating from an external clock, the only allowed response is an immediate shutdown.

Refer to AN2033 for details on how to select specific overvoltage fault response options.

### Output Pre-Bias Protection

An output pre-bias condition exists when an externally applied voltage is present on a power supply's output before the power supply's control IC is enabled. After enable is asserted the output voltage is sampled and the initial pulse width is set to match the existing pre-bias voltage and both drivers become active. The output voltage is then ramped to the target output voltage value at a rate equal to the configured  $T_{RISE}$ .

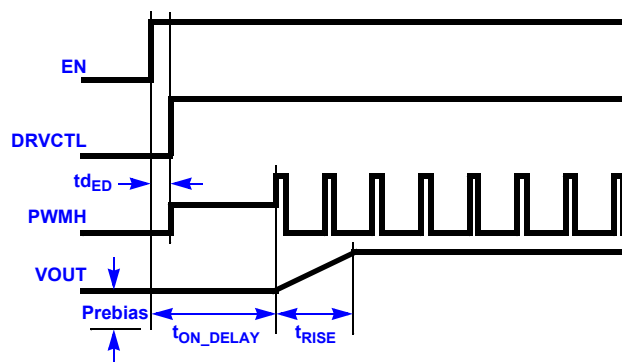

FIGURE 13. TURN-ON INTO PRE-BIAS

When using single input drivers or DrMOS devices the pre-bias is accommodated with the Tri-State PWMH and DRVCTL outputs. When DRVCTL is deasserted the control and Sync FET gates are active low. When DRVCTL is asserted PWMH becomes tri-state and both FET gates remain active low. After the configured  $t_{ON\_DELAY}$  PWMH is adjusted to match the pre-bias voltage and VOUT will begin ramping from the pre-bias value. See Figure 13.

When powering down into a pre-bias VOUT is driven to 0V at a rate equal to the configured  $T_{fall}$ . After the tri-state delay ( $3S\_delay$ ) PWMH becomes tri-stated and VOUT will transition towards the pre-bias voltage. After the tri-state delay off period ( $td_{OFF}$ ) DRVCTL de-asserts coincidentally with PWMH going active low. Both the Control and Sync FET will be active low and VOUT will ramp towards the pre-bias voltage. See Figure 14.

### Minimum Duty Cycle

The ZL8101 is capable of producing output pulses as small as 5ns, however external drivers are not capable of pulses smaller than their minimum processing requirement. The minimum



required pulse width is often specified in the product data sheet. If the external driver is presented with pulse(s) below the minimum requirement the control pulse will not be processed and the gate-high output pulse will not be present. The driver will still deliver a complementary Gate-Low pulse. If a pre-bias is present the output will discharge towards zero until the PWM input is wide enough to meet the minimum required by the driver, this affect is shown in Figure 15.

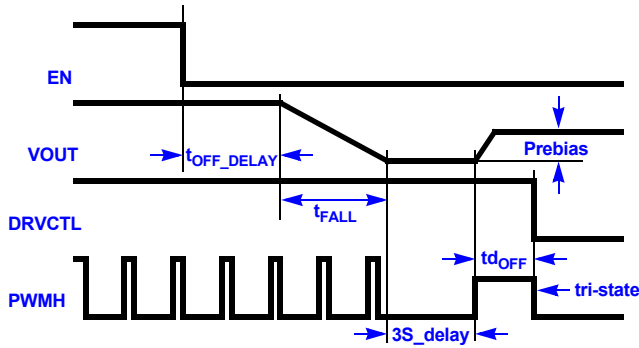

FIGURE 14. TURN\_OFF WITH PRE\_BIAS

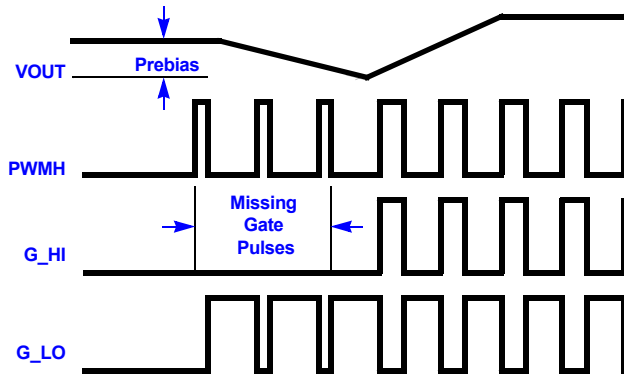

FIGURE 15. INITIAL PWM BELOW MINIMUM REQUIREMENT

To ensure that PWM pulses below the required minimum are not produced enable the Minimum Duty Cycle feature located within the USER\_CONFIG field and select the option that is slightly above the minimum value required by the driver. The actual minimum duty cycle time is given by EQ 30.

$$\text{MinDuty} = N \times \frac{T_{sw}}{256} \tag{EQ. 30}$$

N = Minimum Duty Cycle Count  
 Tsw = Period of Switching Frequency  
 MinDuty = Minimum Duty Cycle Time

The Minimum Duty Cycle parameter is also required to be set when configuring current sharing, enabling minimum a minimum duty cycle ensures that each controller produces a known initial pulse which helps balance inter-phase currents during ramps. Configure the minimum duty cycle to be slightly above the value specified in the driver data sheet.

The Minimum Duty Cycle parameter is part of the USER\_CONFIG field and is comprised of the last 3 MSB's. The range of configurable values is shown below in Table 14.

TABLE 14. USER\_CONFIG MIN DUTY HEX VALUES

MINIMUM DUTY CYCLE	
MINIMUM DUTY COUNT	USER_CONFIG
Disabled	0x00xx
2	0x40xx
4	0x80xx
6	0xC0xx
8	0x20xx
10	0x60xx
12	0xA0xx
14	0xE0xx

### Output Overcurrent Protection

The ZL8101 can protect the power supply from damage if the output is shorted to ground or if an overload condition is imposed on the output. Once the current limit threshold has been selected (see "Current Limit Threshold Selection" on page 20), the user may determine the desired course of action in response to the fault condition. The following overcurrent protection response options are available:

1. Initiate a shutdown and attempt to restart an infinite number of times with a preset delay period between attempts.
2. Initiate a shutdown and attempt to restart a preset number of times with a preset delay period between attempts.
3. Continue operating for a given delay period, followed by shutdown if the fault still exists.
4. Continue operating through the fault (this could result in permanent damage to the power supply).
5. Initiate an immediate shutdown.

The default response from an overcurrent fault is an immediate shutdown of the device. The device will continuously check for the presence of the fault condition, and if the fault condition no longer exists the device will be re-enabled.

Refer to [AN2033](#) for details on how to select specific overcurrent fault response options.

### Thermal Overload Protection

The ZL8101 includes an on-chip thermal sensor that continuously measures the internal temperature of the die and shuts down the device when the temperature exceeds the preset limit. The default temperature limit is set to +125 °C in the factory, but the user may set the limit to a different value if desired. See Application Note [AN2033](#) for details. Note that setting a higher thermal limit via the I<sup>2</sup>C/SMBus interface may result in permanent damage to the device. Once the device has been disabled due to an internal temperature fault, the user may select one of several fault response options as follows:

1. Initiate a shutdown and attempt to restart an infinite number of times with a preset delay period between attempts.
2. Initiate a shutdown and attempt to restart a preset number of times with a preset delay period between attempts.
3. Continue operating for a given delay period, followed by shutdown if the fault still exists.
4. Continue operating through the fault (this could result in permanent damage to the power supply).
5. Initiate an immediate shutdown.

If the user has configured the device to restart, the device will wait the preset delay period (if configured to do so) and will then check the device temperature. If the temperature has dropped below a threshold that is approximately +15 °C lower than the selected temperature fault limit, the device will attempt to re-start. If the temperature still exceeds the fault limit the device will wait the preset delay period and retry again.

The default response from a temperature fault is an immediate shutdown of the device. The device will continuously check for the fault condition, and once the fault has cleared the ZL8101 will be re-enabled.

### Voltage Tracking

High performance systems place stringent demands on the order in which the power supply voltages are turned on. This is particularly true when powering FPGAs, ASICs, and other advanced processor devices that require multiple supply voltages to power a single die. In most cases, the I/O interface operates at a higher voltage than the core and therefore the core supply voltage must not exceed the I/O supply voltage according to the manufacturers' specifications. Voltage tracking protects these sensitive ICs by limiting the differential voltage among multiple power supplies during the power-up and power-down sequence.

The ZL8101 integrates a lossless tracking scheme that allows its output to track a voltage that is applied to the VTRK pin with no extra components required. The VTRK pin is an analog input that, when tracking mode is enabled, configures the voltage applied to the VTRK pin to act as a reference for the device's output regulation.

Voltage tracking can be configured by pin-strapping or PMBus, an example of each configuration is shown in Figures 16 and 17.

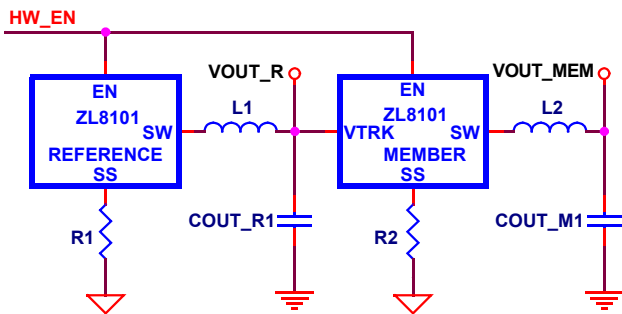

FIGURE 16. PINSTRAP TRACKING

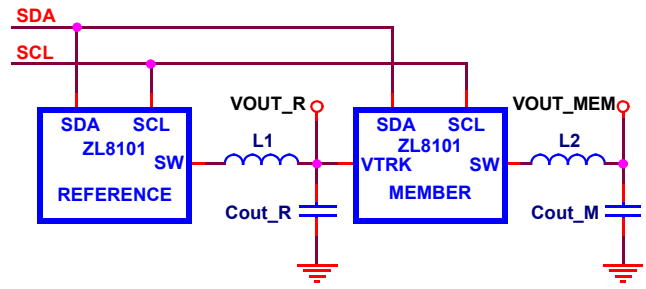

FIGURE 17. PMBus TRACKING

The ZL8101 offers two modes of tracking: coincident and ratiometric. Figure 18 and Figure 19 illustrate the output voltage for the two tracking modes.

1. **Coincident.** This mode configures the ZL8101 to ramp its output voltage at the same rate as the voltage applied to the VTRK pin. Two options are available for this mode;
  - Track at 100% VOUT limited. Member rail tracks the reference rail and stops when the member reaches its configured target voltage. Figure 18 A.
  - Track at 100% VTRK limited. Member rail tracks the reference at the instantaneous voltage value applied to the VTRK pin. Figure 18 B.
2. **Ratiometric.** This mode configures the ZL8101 to ramp its output voltage as a percentage of the voltage applied to the VTRK pin. The default setting is 50%, but an external resistor may be used to configure a different tracking ratio.
  - Track at 50% VOUT limited. Member rail tracks the reference rail and stops when the member reaches 50% of the reference's target voltage, Table 15.
  - Track at 50% VTRK limited. Member rail tracks the reference at the instantaneous voltage value applied to the VTRK pin until the member rail reaches 50% of the reference rail voltage, or if the member is configured to less than 50% of the reference the member will achieve its configured target, Table 15.

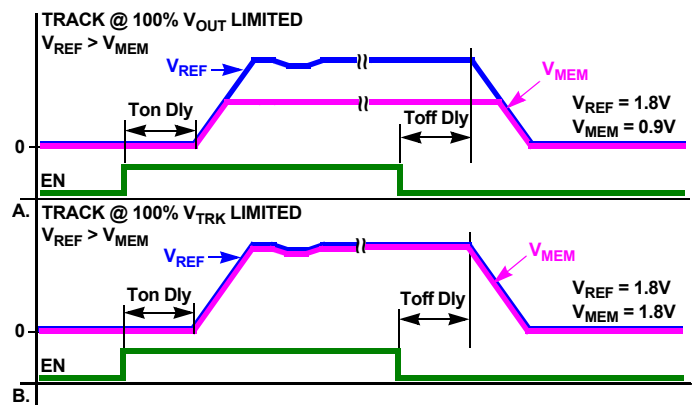

FIGURE 18. COINCIDENT TRACKING

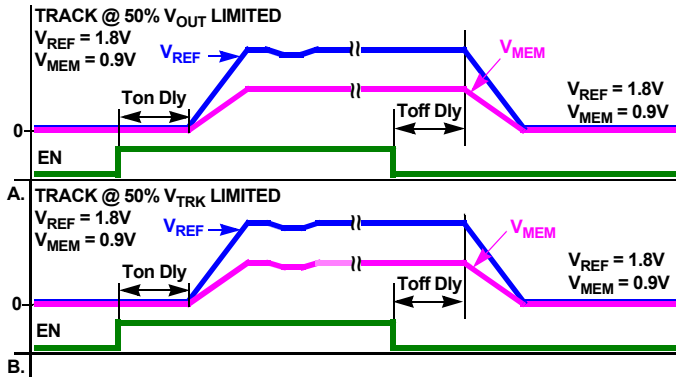

FIGURE 19. RATIOMETRIC TRACKING

### Tracking with Autocomp Enabled

The ZL8101 uses a unique ramping algorithm that results in near perfect tracking while ramping. This is accomplished by deriving different compensator coefficients for ramping than those used for steady-state operation. The ramp compensation is derived from the configured rise/fall time, VIN, and VOUT. While ramping the loop bandwidth is intentionally set to a very low value so response to transients will be limited. The user should limit dynamic loading while ramping. Once the ramp has completed the autocomp algorithm will begin and a new optimized compensator solution will be found. If Autocomp is disabled the controllers will switch to the configured compensator by using the PID Taps defined in the configuration files. If Autocomp is enabled the tracking member Rise/Fall times might need to be adjusted slightly until the desired tracking accuracy is achieved. For the best possible tracking accuracy disable autocomp and manually assign PID coefficients in the configuration file.

### Current Sharing and Tracking

When the ZL8101 is configured in a current sharing group and voltage tracking mode, the VTRK pin of each sharing group member must be tied together, and connected to the reference rail's VOUT node, Figure 23.

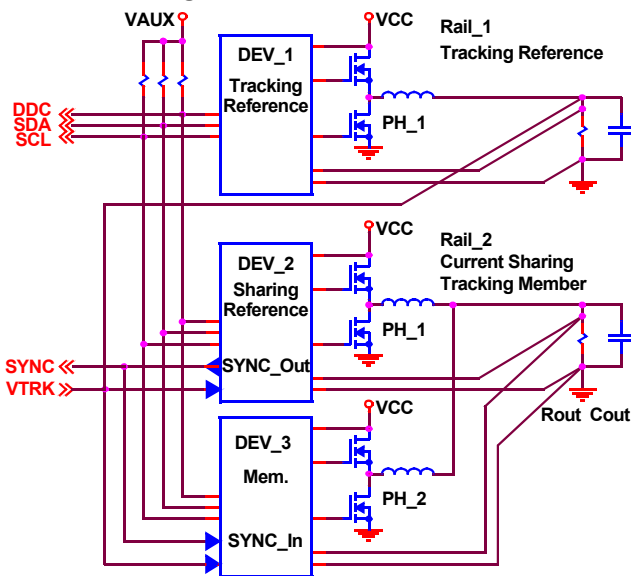

FIGURE 20. TRACKING CURRENT SHARING RAIL

When the Auto Compensation algorithm is used the soft-start values (Rise/Fall times) are used to calculate the loop gain used during the turn-on/turn-off ramps. If current sharing is used constrain the rise/fall time between 5ms and 10ms to ensure current sharing while ramping.

### Configuring Tracking Groups

In a tracking group, the rail output with highest voltage is defined as the reference device. The device(s) that track the reference is called member device(s). The reference device will control the ramp delay and ramp rate of all tracking devices and is not placed in the tracking mode. The reference device is configured to the highest output voltage for the group and all other device(s) output voltages are meant to track and never exceed the reference device output voltage. The reference device must be configured to have a minimum Time-On Delay and Time-On Rise as shown in Equation 31.

$$t_{ON\_DLY}(REF) = t_{ON\_DLY}(MEM) + t_{ON\_RISE}(REF) + 5ms = t_{ON\_DLY}(MEM) + 10ms \quad (EQ. 31)$$

This delay allows the member device(s) to prepare their control loops for tracking following the assertion of ENABLE.

The member device Time-Off Delay has been redefined to describe the time that the VTRK pin will follow the reference voltage after enable is deasserted. The delay setting sets the timeout for the member's output voltage to turnoff in the event that the reference output voltage does not achieve zero volts.

The member device(s) must have a minimum Time-Off Delay of as shown in Equation 32.

$$t_{OFF\_DLY}(MEM) \geq t_{OFF\_DLY}(REF) + t_{OFF\_FALL}(REF) + 5ms \quad (EQ. 32)$$

All of the ENABLE pins must be connected together and driven by a single logic source or a PMBus Broadcast Enable command may be used.

The configuration settings for Figures 18 and 19 are shown below in Tables 15 and 16. In each case, the reference and member rise times are set to the same value.

TABLE 15. TRACKING CONFIGURATION COINCIDENT TRACKING

RAIL	V <sub>OUT</sub> (v)	t <sub>ON\_DLY</sub> (ms)	t <sub>ON\_RISE</sub> (ms)	t <sub>OFF\_DLY</sub> (ms)	t <sub>OFF\_FALL</sub> (ms)	MODE
Reference	1.8	15	5	5	5	Tracking Disabled
Member	0.9	5	5	15	5	100% V <sub>OUT</sub> Limited
Reference	1.8	15	5	5	5	Tracking Disabled
Member	1.8	5	5	15	5	100% VTRK Limited

TABLE 16. TRACKING CONFIGURATION RATIOMETRIC TRACKING

RAIL	V <sub>OUT</sub> (v)	t <sub>ON\_DLY</sub> (ms)	t <sub>ON\_RISE</sub> (ms)	t <sub>OFF\_DLY</sub> (ms)	t <sub>OFF\_FALL</sub> (ms)	MODE
Reference	1.8	15	5	5	5	Tracking Disabled
Member	0.9	5	5	15	5	Track 50% V <sub>OUT</sub> Limited
Reference	1.8	15	5	5	5	Tracking Disabled
Member	1.8	5	5	15	5	Track 50% VTRK Limited

## Voltage Margining

The ZL8101 offers a simple means to vary its output higher or lower than its nominal voltage setting in order to determine whether the load device is capable of operating over its specified supply voltage range. The MGN command is set by driving the MGN pin or through the I<sup>2</sup>C/SMBus interface. The MGN pin is a TTL-compatible input that is continuously monitored and can be driven directly by a processor I/O pin or other logic-level output.

The ZL8101's output will be forced higher than its nominal set point when the MGN command is set HIGH, and the output will be forced lower than its nominal set point when the MGN command is set LOW. Default margin limits of  $V_{NOM} \pm 5\%$  are pre-loaded in the factory, but the margin limits can be modified through the I<sup>2</sup>C/SMBus interface to as high as  $V_{NOM} + 10\%$  or as low as 0V, where  $V_{NOM}$  is the nominal output voltage set point determined by the V0 and V1 pins. A safety feature prevents the user from configuring the output voltage to exceed  $V_{NOM} + 10\%$  under any conditions.

The margin limits and the MGN command can both be set individually through the I<sup>2</sup>C/SMBus interface. Additionally, the transition rate between the nominal output voltage and either margin limit can be configured through the I<sup>2</sup>C interface. Please refer to Application Note [AN2033](#) for detailed instructions on modifying the margining configurations.

## External Voltage Monitoring

The voltage monitoring (VMON) pin is available to monitor the voltage supply for the external driver IC. If the voltage falls below a predefined threshold value (adjustable through a PMBus command), the device will fault and stop sending PWM signals. A 1/16 external resistor divider is required to keep the maximum voltage on this pin to less than 1.15V.

## I<sup>2</sup>C/SMBus Communications

The ZL8101 provides an I<sup>2</sup>C/SMBus digital interface that enables the user to configure all aspects of the device operation as well as monitor the input and output parameters. The ZL8101 can be used with any standard 2-wire I<sup>2</sup>C host device. In addition, the device is compatible with SMBus version 2.0 and includes an SALRT line to help mitigate bandwidth limitations related to continuous fault monitoring. Pull-up resistors are required on the I<sup>2</sup>C/SMBus. The ZL8101 accepts most standard PMBus commands. When controlling the device with PMBus commands, it is recommended that the enable pin is tied to SGND.

## I<sup>2</sup>C/SMBus Device Address Selection

When communicating with multiple SMBus devices using the I<sup>2</sup>C/SMBus interface, each device must have its own unique address so the host can distinguish between the devices. The device address can be set according to the pin-strap options listed in Table 17. Address values are right-justified.

TABLE 17. TRACKING MODE CONFIGURATION

R <sub>SS</sub> (kΩ)	UVLO (V)	TRACKING RATIO (%)	UPPER TRACK LIMIT	RAMP-UP/RAMP-DOWN BEHAVIOR
19.6	4.5	100	Limited by target voltage	Output not allowed to decrease before PG
21.5			Limited by VTRK pin voltage	Output will always follow VTRK
23.7			Limited by target voltage	Output not allowed to decrease before PG
26.1			Limited by VTRK pin voltage	Output will always follow VTRK
28.7		50	Limited by target voltage	Output not allowed to decrease before PG
31.6			Limited by VTRK pin voltage	Output will always follow VTRK
34.8			Limited by target voltage	Output not allowed to decrease before PG
38.3			Limited by VTRK pin voltage	Output will always follow VTRK
42.2	10.8	100	Limited by target voltage	Output not allowed to decrease before PG
46.4			Limited by VTRK pin voltage	Output will always follow VTRK
51.1			Limited by target voltage	Output not allowed to decrease before PG
56.2			Limited by VTRK pin voltage	Output will always follow VTRK
61.9		50	Limited by target voltage	Output not allowed to decrease before PG
68.1			Limited by VTRK pin voltage	Output will always follow VTRK
75			Limited by target voltage	Output not allowed to decrease before PG
82.5			Limited by VTRK pin voltage	Output will always follow VTRK

**TABLE 18. SMBus DEVICE ADDRESS SELECTION**

		SA0		
		LOW	OPEN	HIGH
SA1	LOW	0x20	0x21	0x22
	OPEN	0x23	0x24	0x25
	HIGH	0x26	0x27	Reserved

If additional device addresses are required, a resistor can be connected to the SA0 pin according to Table 18 to provide up to 25 unique device addresses. In this case, the SA1 pin should be tied to SGND.

If more than 25 unique device addresses are required or if other SMBus address values are desired, both the SA0 and SA1 pins can be configured with a resistor to SGND according to Equation 31 and Table 19.

$$\text{SMBusaddress} = 25 \cdot (\text{SA1 index}) + (\text{SA0 index}) \text{ (in decimal)} \quad (\text{EQ. 33})$$

**TABLE 19. SMBus ADDRESS VALUES**

R <sub>SA</sub> (kΩ)	SMBus ADDRESS
10	0x00
11	0x01
12.1	0x02
13.3	0x03
14.7	0x04
16.2	0x05
17.8	0x06
19.6	0x07
21.5	0x08
23.7	0x09
26.1	0x0A
28.7	0x0B
31.6	0x0C
34.8	0x0D
38.3	0x0E
42.2	0x0F
46.4	0x10
51.1	0x11
56.2	0x12
61.9	0x13
68.1	0x14
75	0x15
82.5	0x16
90.9	0x17
100	0x18

Using this method, the user can theoretically configure up to 625 unique SMBus addresses, however the SMBus is inherently limited to 128 devices so attempting to configure an address higher than 128 (0x80) will cause the device address to repeat

(i.e., attempting to configure a device address of 129 (0x81) would result in a device address of 1). Therefore, the user should use index values 0-4 on the SA1 pin and the full range of index values on the SA0 pin, which will provide 125 device address combinations.

Note that the SMBus address 0x4B is reserved for device test and cannot be used in the system.

**TABLE 20. SMBus ADDRESS INDEX VALUES**

R <sub>SA</sub> (kΩ)	SA0 OR SA1 INDEX
10	0
11	1
12.1	2
13.3	3
14.7	4
16.2	5
17.8	6
19.6	7
21.5	8
23.7	9
26.1	10
28.7	11
31.6	12
34.8	13
38.3	14
42.2	15
46.4	16
51.1	17
56.2	18
61.9	19
68.1	20
75	21
82.5	22
90.9	23
100	24

To determine the SA0 and SA1 resistor values given an SMBus address (in decimal), follow steps 1 through 5 to calculate an index value and then use Table 19 to select the resistor that corresponds to the calculated index value as follows:

1. Calculate SA1 Index:  
SA1 Index = Address (in decimal) ÷ 25
2. Round the result down to the nearest whole number.
3. Select the value of R1 from Table 19 using the SA1 Index rounded value from Step 2.
4. Calculate SA0 Index:  
SA0 Index = Address – (25 x SA1 Index)
5. Select the value of R0 from Table 19 using the SA0 Index value from Step 4.

## Digital-DC Bus

The Digital-DC Communications (DDC) bus is used to communicate between Zilker Labs Digital-DC devices. This dedicated bus provides the communication channel between devices for features such as sequencing, fault spreading, and current sharing. The DDC pin on all Digital-DC devices in an application should be connected together. A pull-up resistor is required on the DDC bus in order to guarantee the rise time as follows:

$$\text{Rise time} = R_{PU} \cdot C_{LOAD} \approx 1 \mu\text{s} \quad (\text{EQ. 34})$$

where  $R_{PU}$  is the DDC bus pull-up resistance and  $C_{LOAD}$  is the bus loading. The pull-up resistor may be tied to VR or to an external 3.3V or 5V supply as long as this voltage is present prior to or during device power-up. As rules of thumb, each device connected to the DDC bus presents  $\sim 10\text{pF}$  of capacitive loading, and each inch of FR4 PCB trace introduces  $\sim 2\text{pF}$ . The ideal design will use a central pull-up resistor that is well-matched to the total load capacitance. In power module applications, the user should consider whether to place the pull-up resistor on the module or on the PCB of the end application. The minimum pull-up resistance should be limited to a value that enables any device to assert the bus to a voltage that will ensure a logic 0 (typically 0.8V at the device monitoring point) given the pull-up voltage (5V if tied to VR) and the pull-down current capability of the ZL8101 (nominally 4mA).

## Phase Spreading

When multiple point of load converters share a common DC input supply, it is desirable to adjust the clock phase offset of each device such that not all devices start to switch simultaneously. Setting each converter to start its switching cycle at a different point in time can dramatically reduce input capacitance requirements and efficiency losses. Since the peak current drawn from the input supply is effectively spread out over a period of time, the peak current drawn at any given moment is reduced and the power losses proportional to the  $I_{RMS}^2$  are reduced dramatically.

In order to enable phase spreading, all converters must be synchronized to the same switching clock. The PMBus is used to set the configuration of the SYNC pin for each device as described in "Switching Frequency and PLL" on page 17.

Selecting the phase offset for the device is accomplished by selecting a device address according to Equation 35:

$$\text{Phase offset} = \text{device address} \times 45^\circ \quad (\text{EQ. 35})$$

For example:

- A device address of 0x00 or 0x20 would configure no phase offset
- A device address of 0x01 or 0x21 would configure  $45^\circ$  of phase offset
- A device address of 0x02 or 0x22 would configure  $90^\circ$  of phase offset

The phase offset of each device may also be set to any value between  $0^\circ$  and  $360^\circ$  in  $22.5^\circ$  increments via the I<sup>2</sup>C/SMBus interface. Refer to Application Note [AN2033](#) for further details.

## Output Sequencing

A group of Zilker Labs devices may be configured to power up in a predetermined sequence. This feature is especially useful when powering advanced processors, FPGAs, and ASICs that require one supply to reach its operating voltage prior to another supply reaching its operating voltage in order to avoid latch-up from occurring. Multi-device sequencing can be achieved by configuring each device through the I<sup>2</sup>C/SMBus interface or by using Zilker Labs patented autonomous sequencing mode.

Autonomous sequencing mode configures sequencing by using events transmitted between devices over the DDC bus. The sequencing order is determined using each device's DDC Rail ID number and selecting the DDC Rail ID# Prequel and Sequel for each ZL controller in the sequencing group. The DDC Rail ID# number is automatically assigned and based on the last 5 LSB's of the SMBus address. Care must be taken when configuring the address to ensure that duplicate Rail ID's are not created, since they repeat for every 32 consecutive SMBus addresses. If a current sharing group is part of the sequencing group use the common ISHARE Rail ID to define the Prequel/Sequel function.

To configure autonomous sequencing mode, the I<sup>2</sup>C/SMBus interface must be used, the sequencing function is not available using pinstraps.

The sequencing group will turn on in order starting with the 1st device (no Prequel assigned) and continue to the configured Sequel and so on. When turning off, the sequencing group will reverse the startup order.

The Enable pins and DDCBus of all devices in a sequencing group must be tied together and driven high to initiate a sequenced turn-on of the group. Each sequencing event is triggered by the Prequel controllers power-good assertion which is then forwarded via the DDCBus.

Enable must be driven low to initiate a sequenced turnoff of the group.

Refer to Application Note [AN2033](#) for details on sequencing via the I<sup>2</sup>C/SMBus interface.



### Fault Spreading

Digital DC devices can be configured to broadcast a fault event over the DDC bus to the other devices in the group. When a non-destructive fault occurs and the device is configured to shut down on a fault, the device will shut down and broadcast the fault event over the DDC bus. The other devices on the DDC bus will shut down together if configured to do so, and will attempt to re-start in their prescribed order if configured to do so.

### Active Current Sharing

Paralleling multiple ZL8101 devices can be used to increase the output current capability of a single power rail. By connecting the DDC pins of each device together and configuring the devices as a current sharing rail, the units will share the load current equally within a few percent.

Figure 21 shows a typical connection for three current sharing controllers. Up to 7 controllers may be used in a current sharing group.

The ZL8101 uses a low-bandwidth, first-order digital current sharing technique to balance the unequal phase currents by aligning the load lines of member devices to the reference device.

Droop is used to ensure that any phase that begins to draw a higher current than the others will quickly regulate to a lower voltage, and thereby divert current to another phase.

The ZL8101 controller with the lowest PMBus address becomes the reference device. The remaining devices are called members. The reference device broadcasts its current over the DDC bus. The members adjust their VOUT\_TRIM parameter until current balance is achieved.

Figure 22 shows that, for load lines with identical slopes, the member voltage is increased towards the reference voltage if the reference controller has a higher load current, which closes the gap between the inductor currents.

The relation between reference and member current and voltage is given by Equation 36.

Where R is the value of the droop resistance

$$V_{member} = V_{OUT} + R \times (I_{REFERENCE} - I_{MEMBER}) \quad (EQ. 36)$$

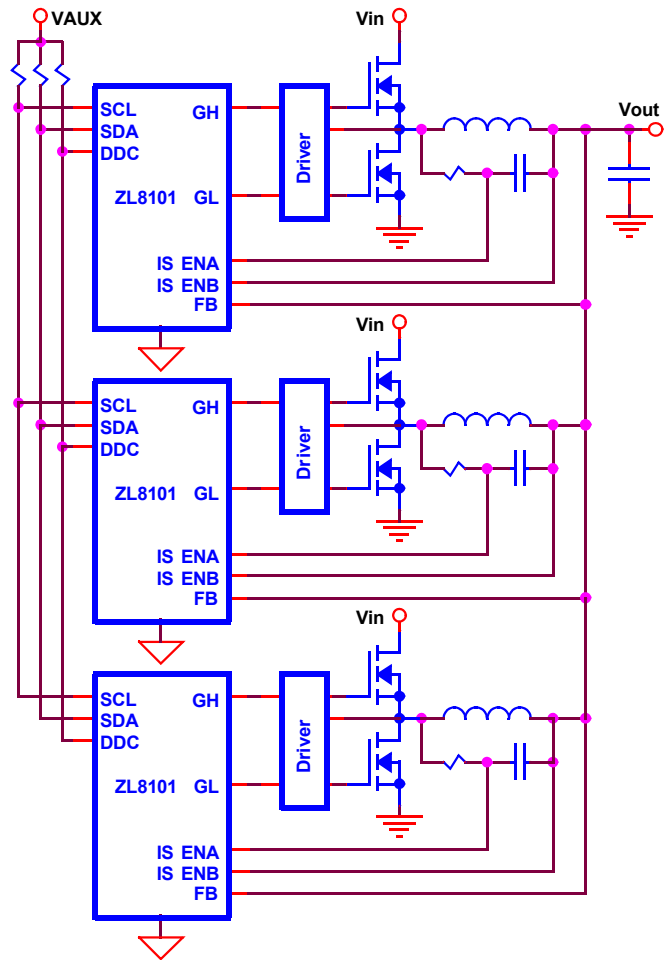

FIGURE 21. CURRENT SHARING GROUP

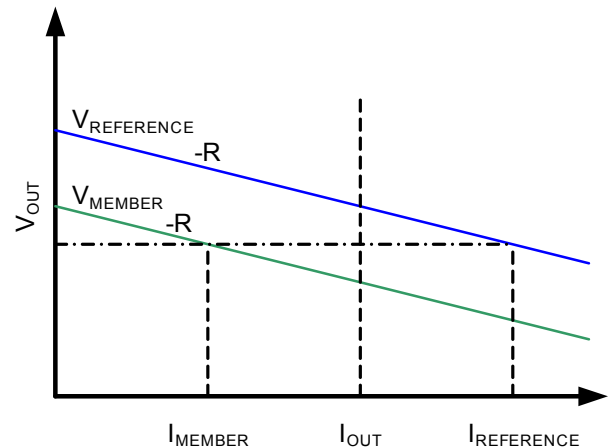

FIGURE 22. ACTIVE CURRENT SHARING

The ISHARE\_CONFIG command is used to configure the device for active current sharing. The default setting is a stand-alone non-current sharing device. A current sharing rail can be part of a sequencing group.

### Turn-On/Off Ramp Behavior

The ZL8101 uses a unique ramping algorithm that results in near perfect current sharing while ramping. This is accomplished by deriving different compensator coefficients for ramping then those used for steady-state operation. The PID taps for ramps is not user configurable.

The ramp compensation is calculated from the configured rise/fall time, measured Vin, and target Vout values. While ramping the loop bandwidth is intentionally set to a very low value so response to transients will be limited. The user should disable dynamic loading while ramping. Once the ramp has completed the autocomp algorithm will begin and a new optimized compensator solution will be found. If Autocomp is disabled the controllers will switch to the configured compensator by using the PID Taps defined in the configuration files.

### Current Share Fault Behavior

Faults within a current sharing group are not broadcast to controllers within the group. If one of the controllers detects a fault that controller will cease operation. The voltage rail will operate normally until all controllers in the group detect a fault and the entire rail has been disabled. Once each controller in the sharing group has faulted the group will respond according to its configured fault response. If fault spreading is enabled, the current share rail failure is not broadcast until the entire current share rail fails.

Once a current sharing controller has faulted the remaining members autonomously redistribute their phase relationship with respect to the Sync Clock. If the faulted controller was the reference phase the standing controller with the lowest PMBus address will become the new reference controller.

### Phase Adding/Dropping

The ZL8101 allows multiple power converters to be connected in parallel to supply higher load currents than can be obtained by using a single-phase design. In doing so, the power converter is optimized at a load current range that requires all phases to be operational. During periods of light loading, it may be beneficial to disable one or more phases in order to reduce the current drain and switching losses associated with those phases, resulting in higher efficiency.

The ZL8101 offers the ability to add and drop phases using a simple command in response to an observed load current change, enabling the system to continuously optimize overall efficiency across a wide load range. All phases in a current share rail are considered active prior to the current sharing rail ramp to power-good.

Phases can be dropped after power-good is asserted. Any member of the current sharing rail can be dropped. If the reference device is dropped, the remaining active device with the lowest PMBus Address will become the new reference.

Any change to the number of members of a current sharing rail will precipitate autonomous phase distribution within the rail where all active phases realign their phase position based on their order within the number of active members.

### Current Share Checklist

Ensure that the following layout guidelines are observed when designing current sharing rails

1. Create a common SGND plane Figure 23
2. Connect bypass caps and pinstrap resistors to SGND Figure 23
3. Ensure that current sense nets are Kelvin Connected
4. Ensure that each voltage FB net is Kelvin connected

Terminate high frequency input/output caps to Low-Side FET Source.

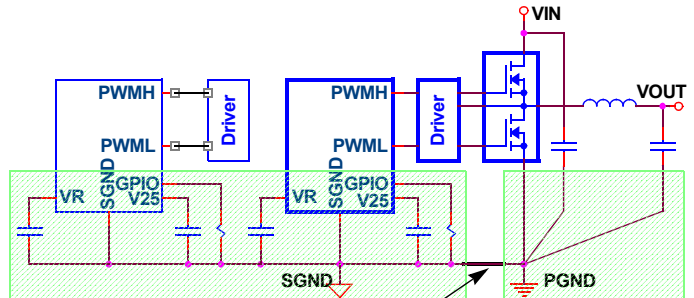

Single point ground unification connection  
All current sharing controllers have a common SGND plane

FIGURE 23. COMMON SGND PLANE FOR CURRENT SHARING

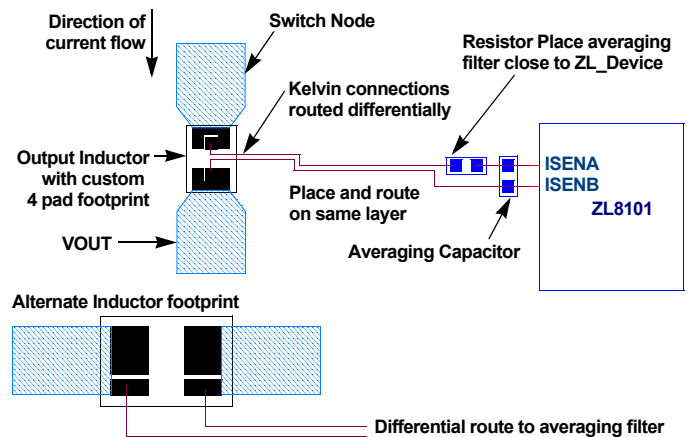

FIGURE 24. KELVIN CONNECTION EXAMPLES

For additional information about Current Sharing please reference [AN2034](#).

### Monitoring Via I<sup>2</sup>C/SMBus

A system controller can monitor a wide variety of different ZL8101 system parameters through the I<sup>2</sup>C/SMBus interface. The device can monitor for fault conditions by monitoring the SALRT pin, which will be asserted when any number of pre-configured fault conditions occur.



The device can also be monitored continuously for any number of power conversion parameters including but not limited to the following:

- Input voltage
- Output voltage
- Output current
- Internal junction temperature
- Temperature of an external device
- Switching frequency
- Duty cycle

The PMBus Host should respond to SALRT as follows:

1. ZL device pulls SALRT Low.
2. PMBus Host detects that SALRT is now low, performs transmission with Alert Response Address to find which ZL device is pulling SALRT low.
3. PMBus Host talks to the ZL device that has pulled SALRT low. The actions that the host performs are up to the System Designer.

If multiple devices are faulting, SALRT will still be low after doing the above steps and will require transmission with the Alert Response Address repeatedly until all faults are cleared.

Please refer to Application Note [AN2033](#) for details on how to monitor specific parameters via the I<sup>2</sup>C/SMBus interface.

### Temperature Monitoring Using the XTEMP Pin

The ZL8101 supports measurement of an external device temperature using either a thermal diode integrated in a processor, FPGA or ASIC, or using a discrete diode-connected 2N3904 NPN transistor. Illustrates the typical connections required.

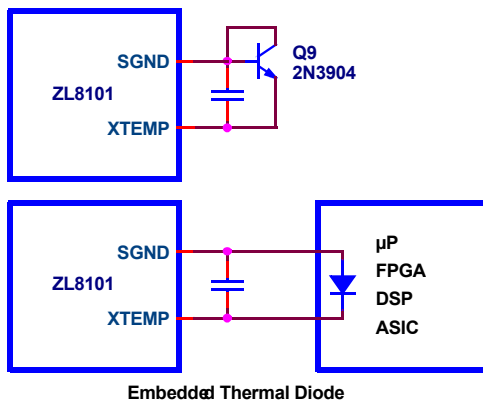

FIGURE 25. XTEMP PIN CONNECTION

### Snapshot™ Parameter Capture

The ZL8101 offers a special mechanism that enables the user to capture parametric data during normal operation or following a fault. The Snapshot functionality is enabled by setting bit 1 of MISC\_CONFIG to 1.

See [AN2033](#) “Zilker Labs PMBus Command Set - DDC Products” for details on using the Snapshot feature in addition to the parameters supported. The Snapshot feature enables the user to read status and parameters via a block read transfer through the

SMBus. This can be done during normal operation, although it should be noted that reading the 22 bytes will occupy the SMBus for some time.

The SNAPSHOT\_CONTROL command enables the user to store the snapshot parameters to Flash memory in response to a pending fault as well as to read the stored data from Flash memory after a fault has occurred. Table 21 describes the usage of this command. Automatic writes to Flash memory following a fault are triggered when any fault threshold level is exceeded, provided that the specific fault’s response is to shut down (writing to Flash memory is not allowed if the device is configured to re-try following the specific fault condition).

It should also be noted that the device’s V<sub>DD</sub> voltage must be maintained during the time when the device is writing the data to Flash memory; a process that requires between 700µs to 1400µs depending on whether the data is set up for a block write. Undesirable results may be observed if the device’s V<sub>DD</sub> supply drops below 3.0V during this process.

TABLE 21. SNAPSHOT\_CONTROL COMMAND

DATA VALUE	DESCRIPTION
1	Copies current SNAPSHOT values from Flash memory to RAM for immediate access using SNAPSHOT command.
2	Writes current SNAPSHOT values to Flash memory. Only available when device is disabled.

In the event that the device experiences a fault & power is lost, the user can extract the last SNAPSHOT parameters stored during the fault by writing a 1 to SNAPSHOT\_CONTROL (transfers data from Flash memory to RAM) and then issuing a SNAPSHOT command (reads data from RAM via SMBus).

### Non-Volatile Memory and Device Security Features

The ZL8101 has internal non-volatile memory where user configurations are stored. Integrated security measures ensure that the user can only restore the device to a level that has been made available to them. Refer to “Start-up Procedure” on page 16 for details on how the device loads stored values from internal memory during start-up. During the initialization process, the ZL8101 checks for stored values contained in its internal non-volatile memory. The ZL8101 offers two internal memory storage units that are accessible by the user as follows:

1. **Default Store:** A power supply module manufacturer may want to protect the module from damage by preventing the user from being able to modify certain values that are related to the physical construction of the module. In this case, the module manufacturer would use the Default Store and would allow the user to restore the device to its default setting but would restrict the user from restoring the device to the factory settings.
2. **User Store:** The manufacturer of a piece of equipment may want to provide the ability to modify certain power supply settings while still protecting the equipment from modifying values that can lead to a system level fault. The equipment manufacturer would use the User Store to achieve this goal.

Please refer to Application Note [AN2033](#) for details on how to set specific security measures via the I<sup>2</sup>C/SMBus interface.

## Configuration Files

Zilker Labs Digital-DC™ devices must be configured through pin-strap settings or by using PMBus™ commands. A configuration file is a human-readable text file that contains a sequence of PMBus commands to be written to a device. Configuration files also aid in sharing device settings to others for additional development, troubleshooting, or manufacturing. Configuration files are text files that can easily be edited using a text editor such as Microsoft Notepad or they can be created by the Power Navigator GUI application.

## Programmable Gain Amplifier Bias Current

A simplified schematic for the voltage sense amplifier is shown below in Figure 26. The Amplifier can source a maximum of  $100\mu\text{A}$  when  $V_{\text{OUT}} = 0$ . If the load impedance is high  $V_{\text{out}}$  will begin to charge because of the bias current. To avoid any prebias condition place an appropriate bleed resistor across  $V_{\text{out}}$ . If current sharing is used scale the bleed resistor by the number of current sharing controllers.

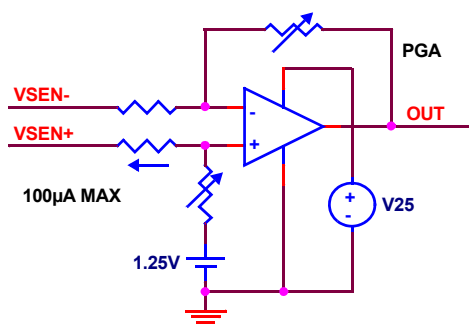

FIGURE 26. PGA BIAS CURRENT

## Revision History

The revision history provided is for informational purposes only and is believed to be accurate, but not warranted. Please go to web to make sure you have the latest Rev.

DATE	REV. #	CHANGE
July 13, 2012	FN7832.1	Initial release

## Products

Intersil Corporation is a leader in the design and manufacture of high-performance analog semiconductors. The Company's products address some of the industry's fastest growing markets, such as, flat panel displays, cell phones, handheld products, and notebooks. Intersil's product families address power management and analog signal processing functions. Go to [www.intersil.com/products](http://www.intersil.com/products) for a complete list of Intersil product families.

For a complete listing of Applications, Related Documentation and Related Parts, please see the respective device information page on intersil.com: [ZL8101](http://www.intersil.com/ZL8101)

To report errors or suggestions for this datasheet, please go to: [www.intersil.com/askourstaff](http://www.intersil.com/askourstaff)

FITs are available from our website at: <http://rel.intersil.com/reports/search.php>

© Copyright Intersil Americas LLC 2011-2012. All Rights Reserved.  
All trademarks and registered trademarks are the property of their respective owners.

For additional products, see [www.intersil.com/en/products.html](http://www.intersil.com/en/products.html)

Intersil products are manufactured, assembled and tested utilizing ISO9001 quality systems as noted in the quality certifications found at [www.intersil.com/en/support/qualandreliability.html](http://www.intersil.com/en/support/qualandreliability.html)

*Intersil products are sold by description only. Intersil may modify the circuit design and/or specifications of products at any time without notice, provided that such modification does not, in Intersil's sole judgment, affect the form, fit or function of the product. Accordingly, the reader is cautioned to verify that datasheets are current before placing orders. Information furnished by Intersil is believed to be accurate and reliable. However, no responsibility is assumed by Intersil or its subsidiaries for its use; nor for any infringements of patents or other rights of third parties which may result from its use. No license is granted by implication or otherwise under any patent or patent rights of Intersil or its subsidiaries. This product is subject to a license from Power One, Inc. related to digital power technology as set forth in U.S. Patent No. 7,000,125 and other related patents owned by Power One, Inc. These license rights do not extend to stand-alone POL regulators unless a royalty is paid to Power One, Inc.*

For information regarding Intersil Corporation and its products, see [www.intersil.com](http://www.intersil.com)

# Package Outline Drawing

## L32.5x5G

32 LEAD QUAD FLAT NO-LEAD PLASTIC PACKAGE

Rev 0, 3/10

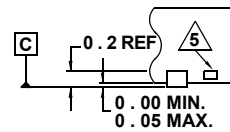
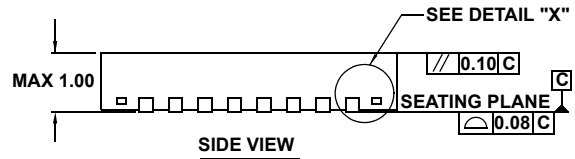
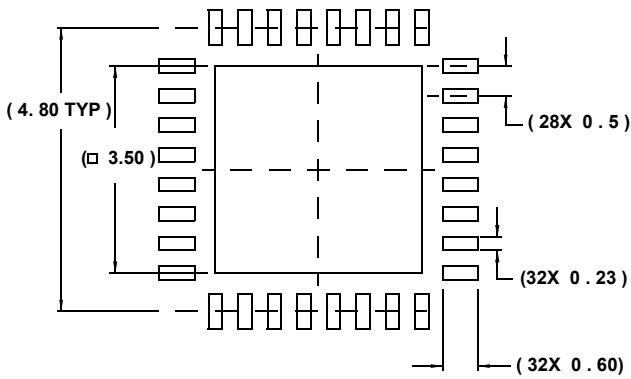
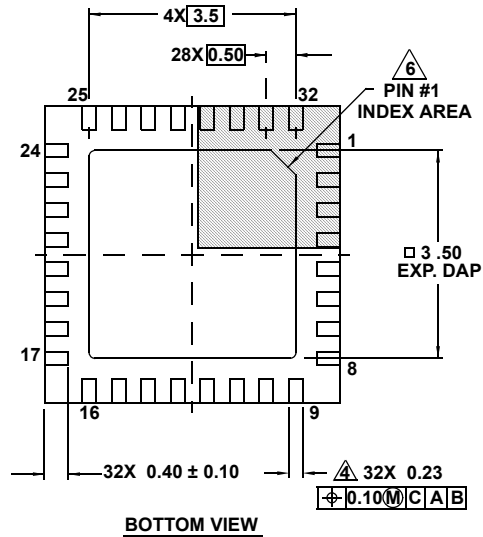
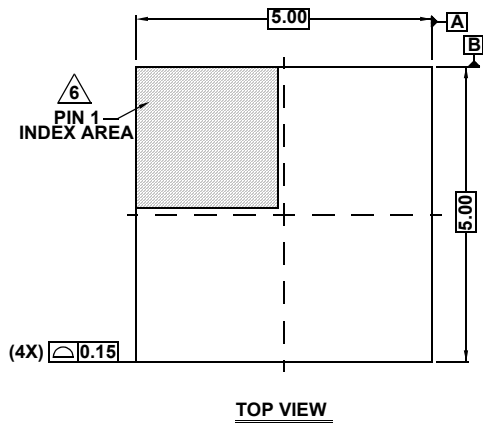

**NOTES:**

1. Dimensions are in millimeters.  
Dimensions in ( ) for Reference Only.
2. Dimensioning and tolerancing conform to ASME Y14.5m-1994.
3. Unless otherwise specified, tolerance: Decimal  $\pm 0.05$
4. Dimension applies to the metallized terminal and is measured between 0.15mm and 0.30mm from the terminal tip.
5. Tiebar shown (if present) is a non-functional feature.
6. The configuration of the pin #1 identifier is optional, but must be located within the zone indicated. The pin #1 identifier may be either a mold or mark feature.

Компания «Океан Электроники» предлагает заключение долгосрочных отношений при поставках импортных электронных компонентов на взаимовыгодных условиях!

Наши преимущества:

- Поставка оригинальных импортных электронных компонентов напрямую с производств Америки, Европы и Азии, а так же с крупнейших складов мира;
- Широкая линейка поставок активных и пассивных импортных электронных компонентов (более 30 млн. наименований);
- Поставка сложных, дефицитных, либо снятых с производства позиций;
- Оперативные сроки поставки под заказ (от 5 рабочих дней);
- Экспресс доставка в любую точку России;
- Помощь Конструкторского Отдела и консультации квалифицированных инженеров;
- Техническая поддержка проекта, помощь в подборе аналогов, поставка прототипов;
- Поставка электронных компонентов под контролем ВП;
- Система менеджмента качества сертифицирована по Международному стандарту ISO 9001;
- При необходимости вся продукция военного и аэрокосмического назначения проходит испытания и сертификацию в лаборатории (по согласованию с заказчиком);
- Поставка специализированных компонентов военного и аэрокосмического уровня качества (Xilinx, Altera, Analog Devices, Intersil, Interpoint, Microsemi, Actel, Aeroflex, Peregrine, VPT, Syfer, Eurofarad, Texas Instruments, MS Kennedy, Miteq, Cobham, E2V, MA-COM, Hittite, Mini-Circuits, General Dynamics и др.);

Компания «Океан Электроники» является официальным дистрибьютором и эксклюзивным представителем в России одного из крупнейших производителей разъемов военного и аэрокосмического назначения «JONHON», а так же официальным дистрибьютором и эксклюзивным представителем в России производителя высокотехнологичных и надежных решений для передачи СВЧ сигналов «FORSTAR».



## JONHON

«JONHON» (основан в 1970 г.)

Разъемы специального, военного и аэрокосмического назначения:

(Применяются в военной, авиационной, аэрокосмической, морской, железнодорожной, горно- и нефтедобывающей отраслях промышленности)

«FORSTAR» (основан в 1998 г.)

ВЧ соединители, коаксиальные кабели, кабельные сборки и микроволновые компоненты:

(Применяются в телекоммуникациях гражданского и специального назначения, в средствах связи, РЛС, а так же военной, авиационной и аэрокосмической отраслях промышленности).



Телефон: 8 (812) 309-75-97 (многоканальный)

Факс: 8 (812) 320-03-32

Электронная почта: [ocean@oceanchips.ru](mailto:ocean@oceanchips.ru)

Web: <http://oceanchips.ru/>

Адрес: 198099, г. Санкт-Петербург, ул. Калинина, д. 2, корп. 4, лит. А