

# IS31LT3117

## 53V, 350mA, 4-CHANNEL CONSTANT CURRENT REGULATOR WITH OTP

Preliminary Information  
March 2015

### GENERAL DESCRIPTION

The IS31LT3117 is a 4-channel, linear regulated, constant current LED driver which can provide 4 equal currents outputs of up to 350mA per channel to drive high brightness LEDs over an input voltage range of 6V to 53V, while maintaining an output leakage current of less than 1 $\mu$ A. The output current is easily programmed using a single, tiny external resistor. The outputs of the IS31LT3117 can be connected in parallel to allow greater than 350mA output current.

The IS31LT3117 also features a PWM input to enable simple dimming control using a digital control signal. The recommended frequency range of the PWM signal is 4kHz ~ 100kHz.

The IS31LT3117 provides a unique over temperature protection scheme. A hard shutdown which turns off all LED currents occurs if the die junction temperature exceeds the maximum value of 160 $^{\circ}$ C. However, as the die junction temperature rises up to over 130 $^{\circ}$ C (Typ.), the output current will begin to roll off at a rate of -2.22%/ $^{\circ}$ C (Typ.). If the die temperature continues to rise above the hard shutdown temperature threshold, the LED currents will drop to zero. When temperature returns to 140 $^{\circ}$ C (Typ.) or below, the hard shutdown protection is released and the chip will function again.

The IS31LT3117 also has an optional 2.5V reference voltage output which is able to supply up to 10mA (typ.) output current. This voltage may be used to drive the base of the external BJTs for higher current applications in such case, driving for a wide varying input voltage is needed.

The IS31LT3117 is offered in eTSSOP-16 package with operating temperature range of -40 $^{\circ}$ C to +125 $^{\circ}$ C.

### TYPICAL APPLICATION CIRCUIT

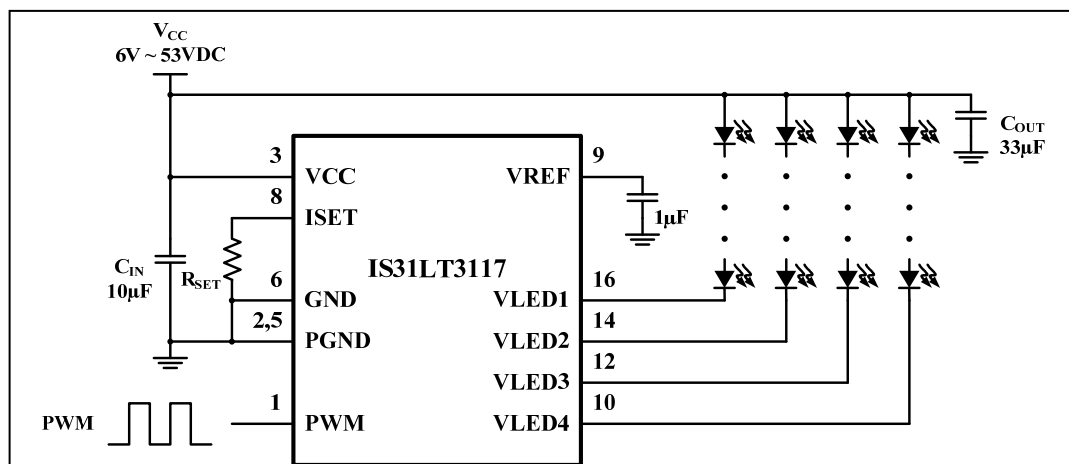

Figure 1 IS31LT3117 Directly Driving 4 LED Strings

### FEATURES

- 6V to 53V input supply voltage range
- Up to 1.4A total output current
- Over temperature protections
- Thermal current regulation above 130 $^{\circ}$ C
- $\pm$ 3% output current matching between channels
- PWM dimming and shutdown control input
- Optional 2.5V output to drive external standoff BJTs
- Very few external components

### APPLICATIONS

- Industrial LED lighting
- Low EMI lighting applications
- Low-side constant current regulator

# IS31LT3117

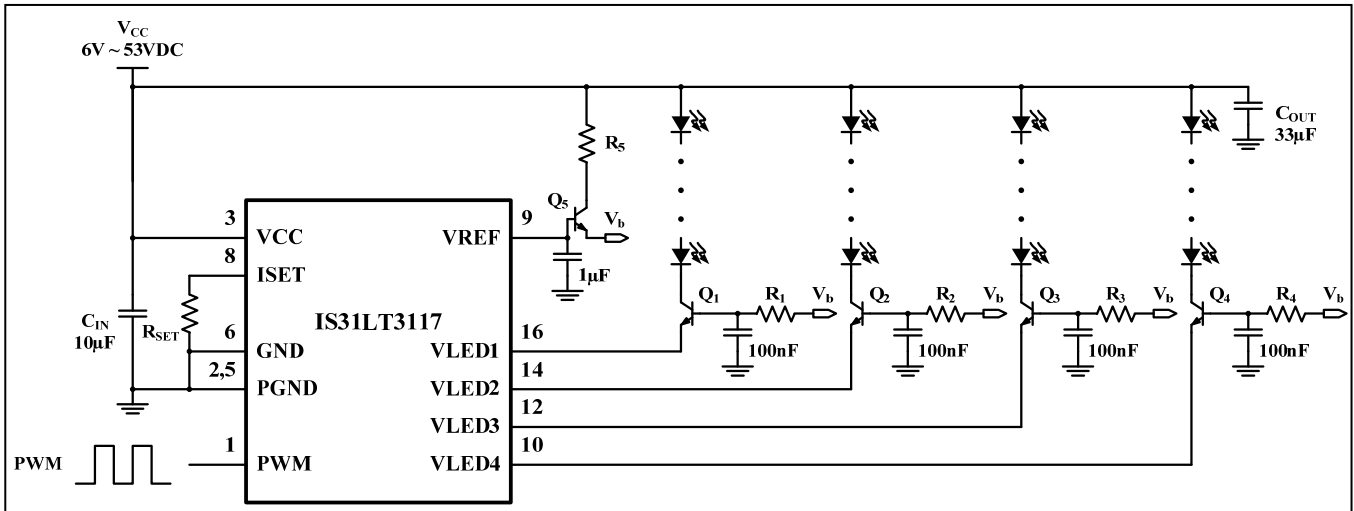

**Figure 2** IS31LT3117 With Optional 2.5V Output Driving 4 External Standoff BJTs

**Note 1:** The 33µF output capacitor should be placed as close to the LED array as possible in order to minimize the parasitic inductor effect due to the output wiring.

**Note 2:** The resistor  $R_{SET}$  should be placed as close to ISET and GND pins as possible.

**Note 3:** If you want less than four channels, the unused channel should be connected to GND.

# IS31LT3117

## PIN CONFIGURATION

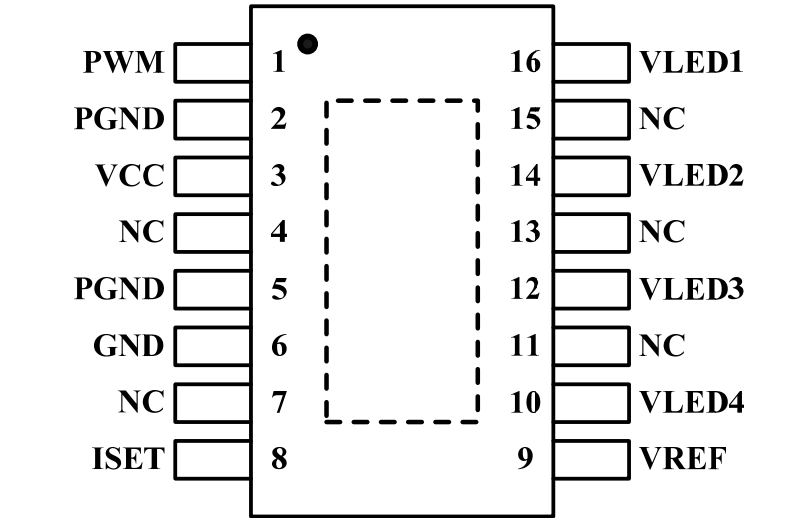
| Package   | Pin Configuration (Top View)   |
|-----------|--|
| eTSSOP-16 |  |

## PIN DESCRIPTION

| No.          | Pin         | Description   |
|--------------|-------------|---|
| 1            | PWM         | PWM control pin. (PWM=high, enable. PWM=low for 3.5ms, disable)   |
| 2, 5         | PGND        | Power ground.   |
| 3            | VCC         | Voltage supply input (6V~53V).  |
| 4,7,11,13,15 | NC          | No connection.  |
| 6            | GND         | Ground.   |
| 8            | ISET        | A resistor from this pin to ground will set all the channel sink currents to the same value.                            |
| 9            | VREF        | 2.5V reference output capable of sourcing 10mA (Typ.). A 1 $\mu$ F capacitor must be connected from this pin to ground. |
| 10,12,14,16  | VLED4~VLED1 | Current source outputs. Each channel should be connected to GND if it is not used.                                      |
|              | Thermal Pad | Connect to ground.  |



# IS31LT3117

## ORDERING INFORMATION

Industrial Range: -40°C to +125°C

| Order Part No.     | Package              | QTY       |
|--------------------|----------------------|-----------|
| IS31LT3117-ZLS4-TR | eTSSOP-16, Lead-free | 2500/Reel |
| IS31LT3117-ZLS4    |                      | 96/Tube   |

Copyright © 2015 Integrated Silicon Solution, Inc. All rights reserved. ISSI reserves the right to make changes to this specification and its products at any time without notice. ISSI assumes no liability arising out of the application or use of any information, products or services described herein. Customers are advised to obtain the latest version of this device specification before relying on any published information and before placing orders for products. Integrated Silicon Solution, Inc. does not recommend the use of any of its products in life support applications where the failure or malfunction of the product can reasonably be expected to cause failure of the life support system or to significantly affect its safety or effectiveness. Products are not authorized for use in such applications unless Integrated Silicon Solution, Inc. receives written assurance to its satisfaction, that:

- a.) the risk of injury or damage has been minimized;
- b.) the user assume all such risks; and
- c.) potential liability of Integrated Silicon Solution, Inc is adequately protected under the circumstances

# IS31LT3117

## ABSOLUTE MAXIMUM RATINGS (NOTE 4)

|   |   |
|---|---|
| VCC pin to GND  | -0.3V ~ +56V  |
| Voltage at PWM and VLEDx pins                                     | -0.3V ~ +56V  |
| Voltage at ISET pin   | -0.3V ~ +6.0V                                       |
| Current at VREF pin   | 10mA  |
| Junction temperature, $T_J$                                       | -40°C ~ +160°C                                      |
| Storage temperature range, $T_{STG}$                              | -65°C ~ +150°C                                      |
| Operating temperature range, $T_A$                                | -40°C ~ +125°C                                      |
| Power dissipation, $P_{D(MAX)}$ (Note 5)                          | 2.5W  |
| Thermal resistance, junction to ambient, still air, $\theta_{JA}$ | 39.9°C/W  |
| ESD (HBM)   | All pins pass 2kV, except all ground pin pass 1.5kV |
| ESD (CDM)   | All pins pass 750V, except Pin 1 passes 100V        |

### Note 4:

Stresses beyond those listed under "Absolute Maximum Ratings" may cause permanent damage to the device. These are stress ratings only and functional operation of the device at these or any other condition beyond those indicated in the operational sections of the specifications is not implied. Exposure to absolute maximum rating conditions for extended periods may affect device reliability.

### Note 5:

Detail information please refers to package thermal de-rating curve on Page 12.

## ELECTRICAL CHARACTERISTICS

Valid are at  $V_{CC} = 12V$ ,  $T_A = T_J = -40^\circ C \sim +125^\circ C$ , typical value at 25°C, unless otherwise noted.

| Symbol        | Parameter  | Conditions  | Min.  | Typ. | Max.  | Unit       |
|---------------|--|---|-------|------|-------|------------|
| $V_{CC}$      | Supply voltage range                               |   | 6.0   |      | 53    | V          |
| $R_{SET}$     | The ISET resistance                                |   | 5.8   |      | 203   | k $\Omega$ |
| $I_{SINK}$    | Output current per channel                         | $R_{SET}=5.8k\Omega$ , PWM=High<br>$V_{VLEDx}=1V$ , $T_A = 25^\circ C$          | 332.5 | 350  | 367.5 | mA         |
| $I_{IN}$      | Quiescent Input supply current                     | $R_{SET}=5.8k\Omega$ , PWM=High   |       |      | 13.8  | mA         |
|               |  | $R_{SET}=203k\Omega$ , PWM=High   |       |      | 6.3   |            |
| $I_{SD}$      | Shutdown input current                             | PWM = Low, $V_{CC}=12V$   |       |      | 90    | $\mu A$    |
| $t_{SD}$      | The time of PWM pin keeping low to shutdown the IC |   | 3.5   |      |       | ms         |
| $f_{PWM}$     | The PWM dimming frequency                          | $V_{CC}=12V$  | 4     |      | 100   | kHz        |
| $V_{HR}$      | Recommended VLED output voltage headroom           | $I_{SINK}=350mA$ (Note 6)   | 0.8   |      |       | V          |
| $I_{LEAKAGE}$ | Leakage current per channel                        | PWM=Low, $V_{VLEDx}=53V$  |       |      | 1     | $\mu A$    |
| $t_{RISE}$    | Output current rise time                           | $R_{SET}=5.8k\Omega$ , PWM=20kHz,<br>current rise from 10%~90%<br>(Note 7)      |       | 300  |       | ns         |
| $t_{FALL}$    | Output current fall time                           | $R_{SET}=5.8k\Omega$ , PWM=20kHz,<br>current fall down from<br>90%~10% (Note 7) |       | 200  |       | ns         |
| $V_{ISET}$    | ISET pin output voltage                            |   | 1.16  | 1.27 | 1.38  | V          |
| $V_{PWMH}$    | PWM pin input logic high voltage                   | $V_{PWM}$ rising  | 1.4   |      |       | V          |
| $V_{PWML}$    | PWM pin input logic low voltage                    | $V_{PWM}$ falling   |       |      | 0.4   | V          |

# IS31LT3117

## ELECTRICAL CHARACTERISTICS (CONTINUE)

Valid are at  $V_{CC} = 12V$ ,  $T_A = T_J = -40^{\circ}C \sim +125^{\circ}C$ , typical value at  $25^{\circ}C$ , unless otherwise noted.

| Symbol                     | Parameter                         | Conditions  | Min. | Typ. | Max. | Unit        |
|----------------------------|-----------------------------------|---|------|------|------|-------------|
| $T_{RO}$                   | Thermal roll off threshold        | (Note 7)  |      | 130  |      | $^{\circ}C$ |
| $T_{SD}$                   | Thermal shutdown threshold        | Temperature rising (Note 7)                       |      | 160  |      | $^{\circ}C$ |
| $T_{SD-HYS}$               | Thermal shutdown hysteresis       | Temperature falling (Note 7)                      |      | 20   |      | $^{\circ}C$ |
| $\Delta I_{SINK}/I_{SINK}$ | Current matching between Channels | $R_{SET}=5.8k\Omega$ , PWM=High<br>$V_{VLEDx}=1V$ | -3   |      | 3    | %           |
| $V_{REF}$                  | Reference voltage output          |   | 2.32 | 2.5  | 2.76 | V           |

**Note 6:** It is a recommended value to ensure a better line regulation of 350mA output current.

**Note 7:** Guarantee by design.

## TYPICAL PERFORMANCE CHARACTERISTICS

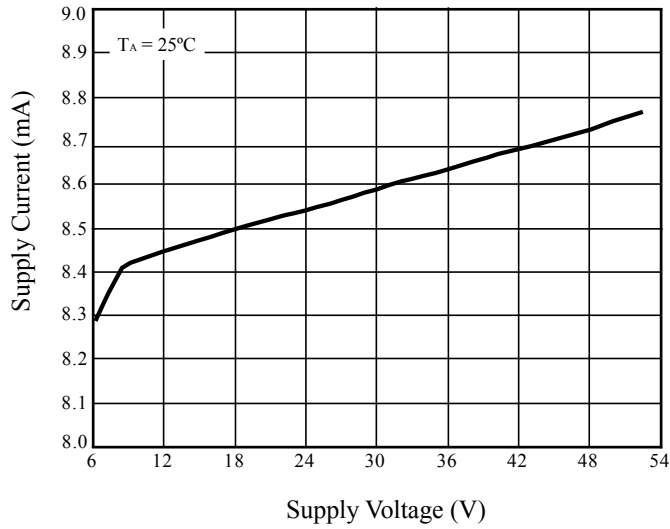

**Figure 3** Supply Current vs. Supply Voltage

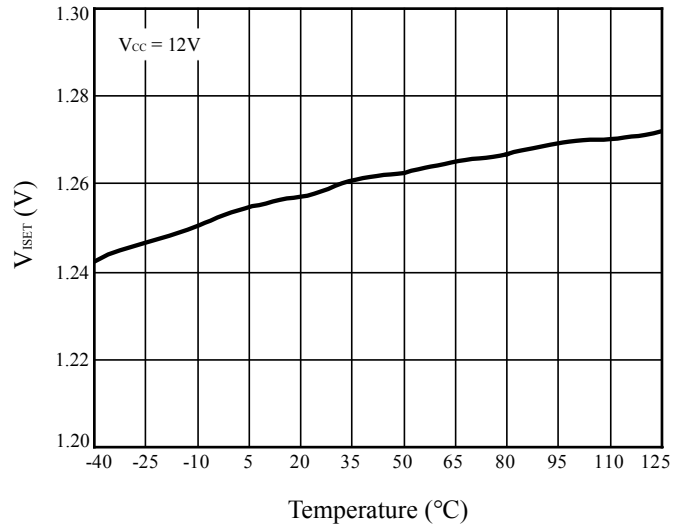

**Figure 4** V<sub>ISET</sub> vs. Temperature

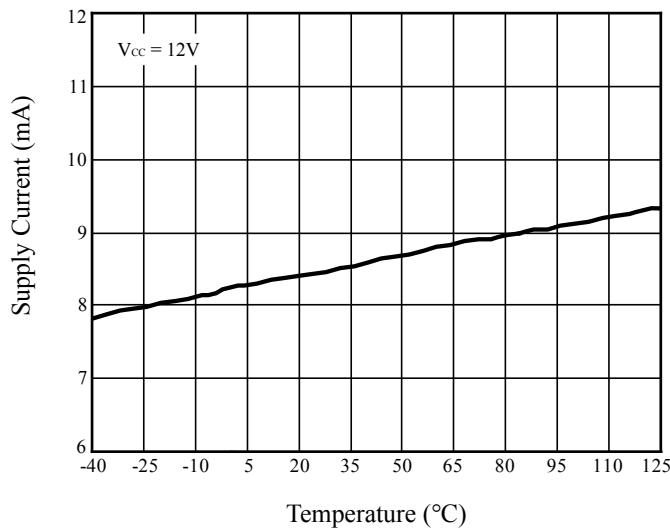

**Figure 5** Supply Current vs. Temperature

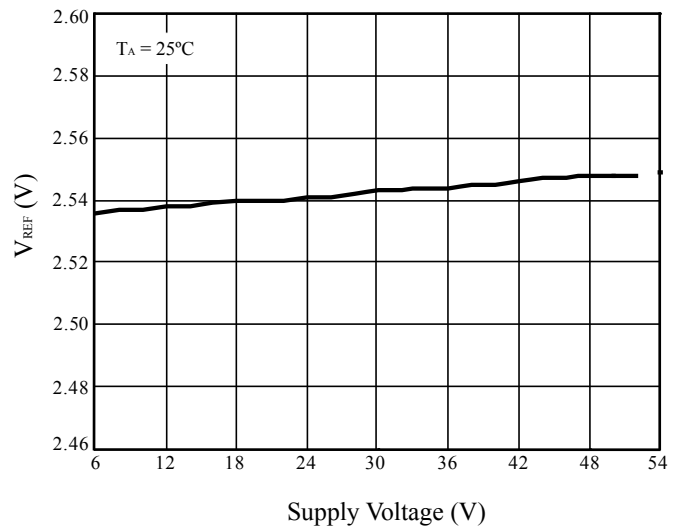

**Figure 6** V<sub>REF</sub> vs. Supply Voltage

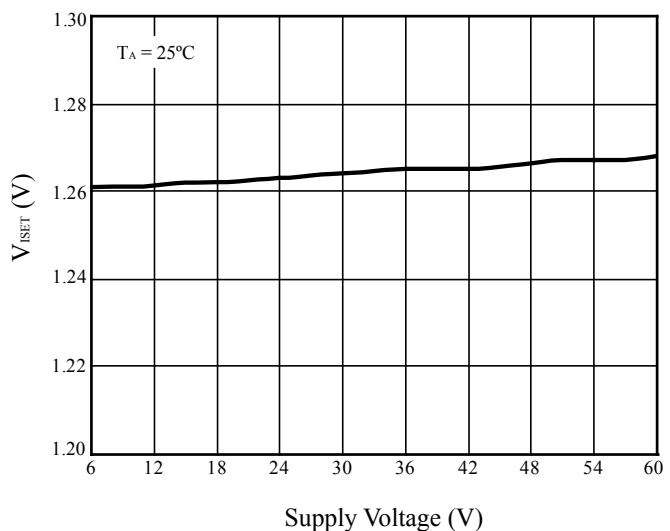

**Figure 7** V<sub>ISET</sub> vs. Supply Voltage

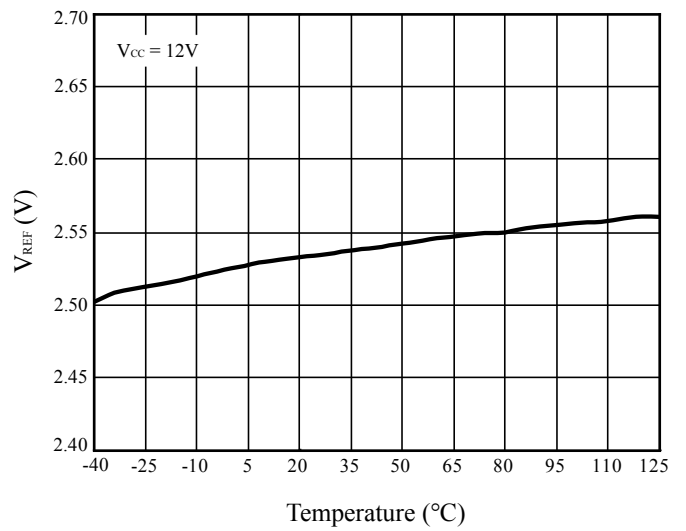

**Figure 8** V<sub>REF</sub> vs. Temperature

# IS31LT3117

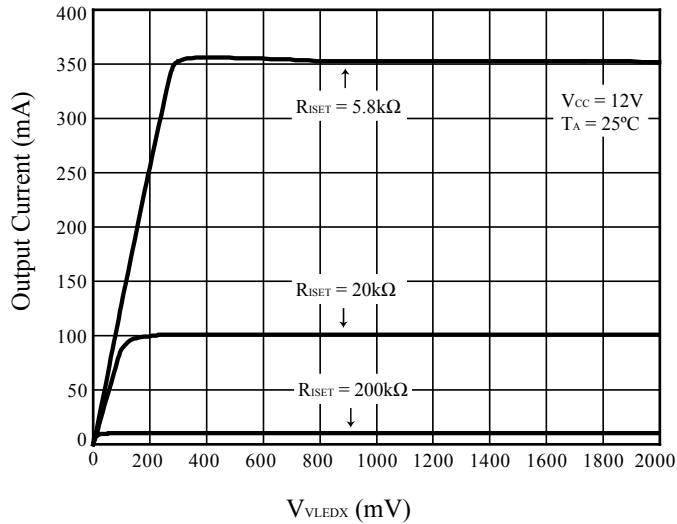

Figure 9 Output Current vs.  $V_{VLEDX}$

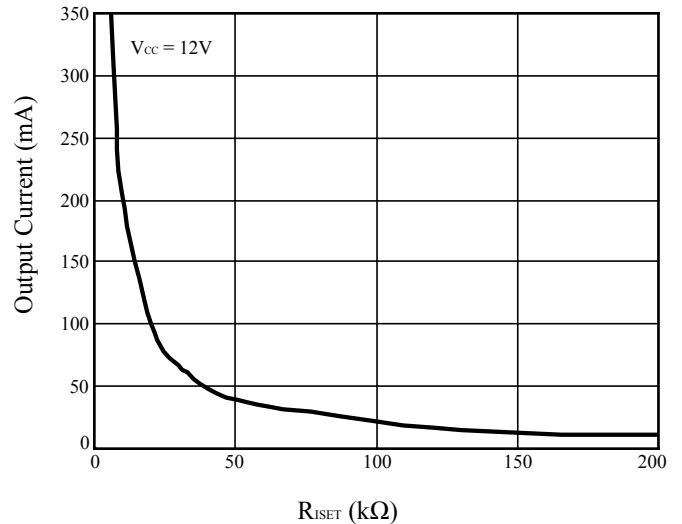

Figure 10 Output Current vs.  $R_{SET}$

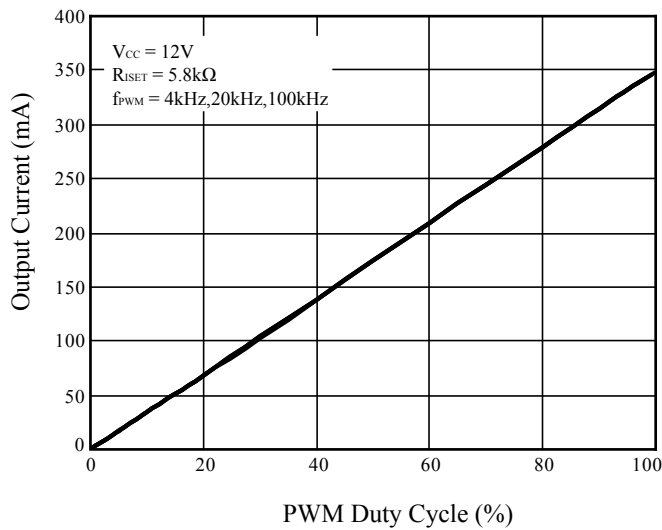

Figure 11 Output Current vs. PWM Duty Cycle

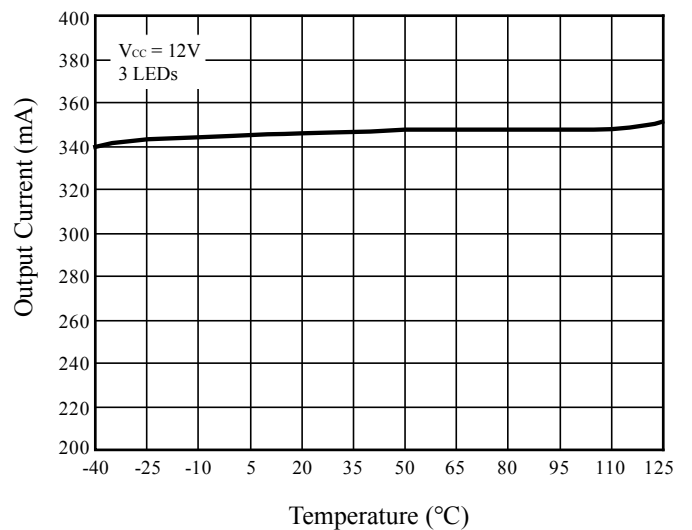

Figure 12 Output Current vs. Temperature

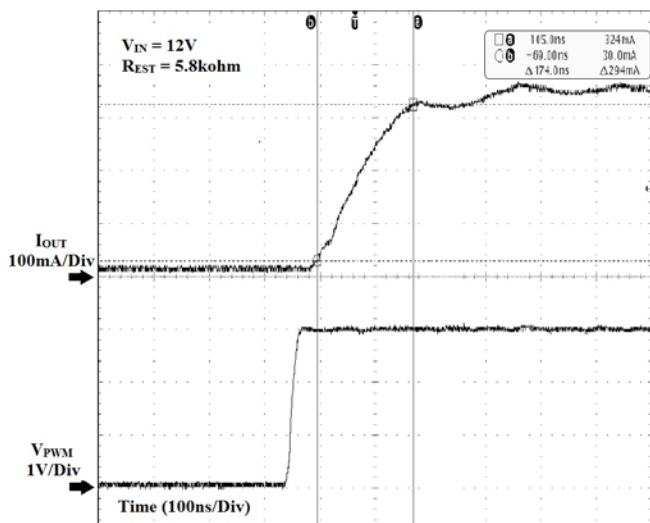

Figure 13 Output Current vs.  $V_{PWM}$  on Rising Time

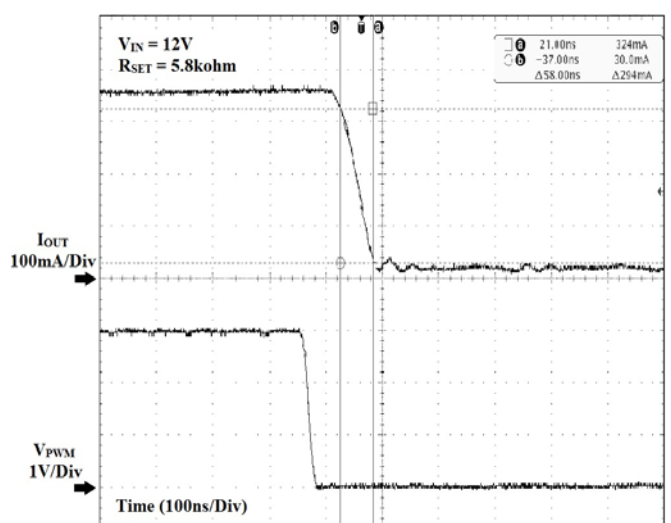
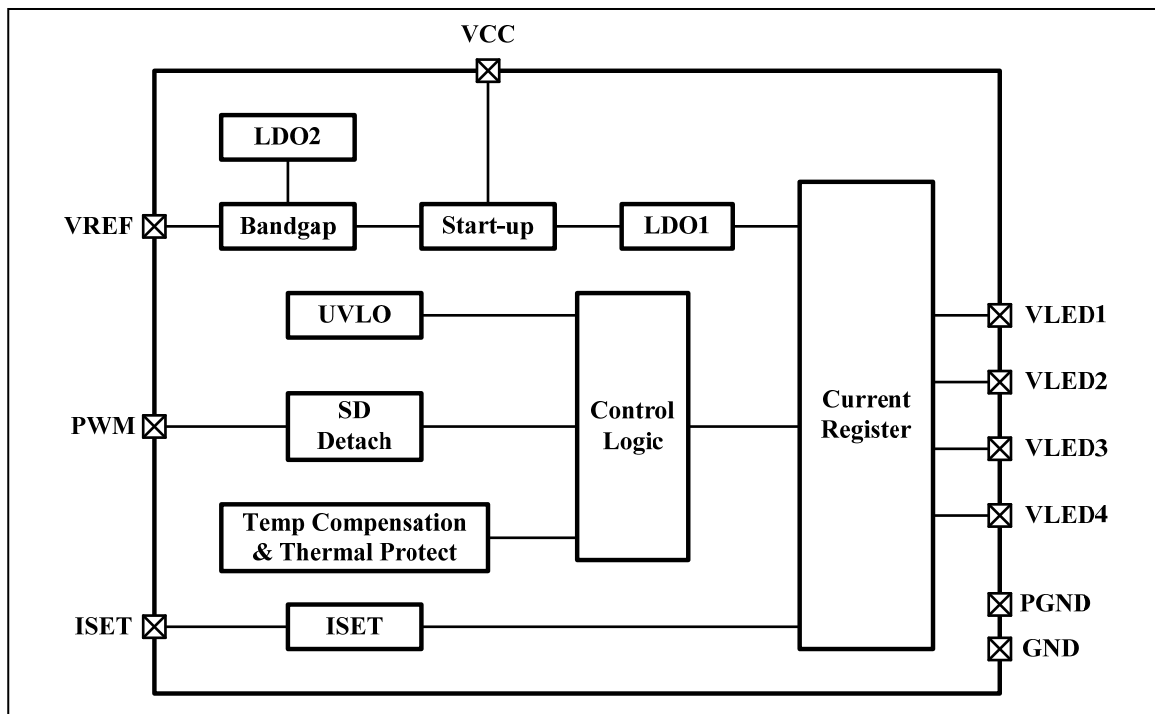

Figure 14 Output Current vs.  $V_{PWM}$  on Falling Time



# IS31LT3117

## FUNCTIONAL BLOCK DIAGRAM



# IS31LT3117

## APPLICATION INFORMATION

### FUNCTIONAL DESCRIPTION

IS31LT3117 is a linear current regulator designed to drive high brightness LEDs. The device integrates 4 channels capable of driving up to 350mA in each channel and operates over a supply voltage range of 6V to 53V. Output current is easily programmed by using a single resistor.

The IS31LT3117 incorporates a special thermal regulation protection feature which prevents the die temperature from exceeding the maximum rated junction temperature of 160°C.

IS31LT3117 features a PWM/enable input which can be used to realize PWM dimming of the LEDs. In addition, the enable input can be used to put the device into a low power consumption shutdown mode. In shutdown, the device consumes only 80µA of supply current.

### VCC

The VCC input pin provides power to the internal circuitry of the entire chip. The device supply current will vary with the output current setting due to the internal reference currents generated for each channel. The nominal supply current is 11.5mA ( $R_{SET}=5.8k\Omega$ ) during operation.

### ISET

The output current for the IS31LT3117 is set by connecting a resistor from the ISET pin to GND. An internal 1.27V reference voltage source will supply a current to the external current setting resistor. The reference current is internally amplified by a gain of 1600 to each of the 4 outputs. In order to have an accurate current output, this current setting resistor must be mounted as close to ISET and AGND pins as possible.

### PWM

When the PWM input pin is at low state ( $V_{PWM} < 0.4V$ ) and stays low for more than 3.5ms, the IS31LT3117 enters a low power consumption mode with all of the outputs turned OFF. In this mode, the IS31LT3117 consumes only 80µA of supply current. When the PWM input pin is at high state ( $V_{PWM} > 1.4V$ ), the IS31LT3117 will enter in operation mode to resume normal operation and all outputs are turned ON. A PWM input signal to the PWM pin can be used for HBLEDD dimming control. The recommended frequency range of PWM signal is 4kHz ~ 100kHz.

### GND

Signal ground current return pin.

### PGND

Power ground current return pin. This pin should be connected to as large as possible of a copper pad on

the PCB to allow the best possible thermal performance of the circuit.

### VLEDx

Constant current regulator channel. Each of the 4 input pins are capable of sinking up to 350mA of current with a headroom voltage  $V_{VLEDx}$  of 0.8V (Min.).

It is recommended to maintain above a 0.8V  $V_{VLEDx}$  to ensure a better line regulation of 350mA output current.

### OUTPUT CURRENT

The maximum sink current of all four channels are set by a single resistor ( $R_{SET}$ ) connected from the ISET pin to ground. The maximum possible current is 350mA per channel. However, any of the four channels can be connected in parallel to allow a larger current output. The channel sink current can be calculated by the following Equation (1):

$$I_{SINKx} = 1600 \times \frac{V_{ISET}}{R_{SET}} \quad (1)$$

Where  $V_{ISET} = 1.27V$  (Typ.)

$R_{SET}$  need to be chosen 1% accuracy resistor with enough power tolerance and good temperature characteristic to ensure stable output current.

The following table shows examples of  $I_{SINKx}$  values for various  $R_{SET}$  settings:

| $I_{SINKx}$ (mA) | $R_{SET}$ (kΩ) |
|------------------|----------------|
| 10               | 203            |
| 100              | 20.3           |
| 350              | 5.8            |

If less than 4 channels are required for a particular application, it is recommended to combine channels together to drive the LEDs. This will help to reduce the individual internal bias currents and, thus, the overall power consumption and heat dissipation of the device.

For example, it can be configured to combine two or four channels to one channel to drive two or one string of LEDs. If only three channels are used, the unused channel should be connected to GND.

### VREF

When time of sinking a high current from a voltage source increases, the headroom voltage ( $V_{VLEDx}$ ) on the current sinks will also increase. This will cause an increase in power dissipation at the current sink, which may result in an increase of the package temperature.

$$V_{VLEDx} = V_{CC} - V_{LEDS} \quad (2)$$

Where  $V_{LEDS} = \text{total LED } V_F \text{ for the channel.}$

# IS31LT3117

To address this thermal condition, the IS31LT3117 integrates a 2.5V reference output which can be used to drive the base of an external BJT. This turns on the BJT and effectively clamps the voltage across the IS31LT3117's output driver to approximately 0.8V. The power dissipation is then shared between the IC and the standoff transistor. The VREF pin can source up to 10mA of current to drive 4 external BJT's, one for each channel.

## OPERATION WITH EXTERNAL BJTS

In most of the applications, the largest power dissipation will be caused by the current regulator. The thermal dissipation is proportional to the headroom voltage ( $V_{VLEDx}$ ) and the sink current flowing through it.

When  $V_{CC}$  is much higher than the  $V_{LEDS}$  or  $I_{SINKx}$  is large, the power dissipation of the IS31LT3117 will be high. This condition may easily trigger the over temperature protection (OTP). Using external standoff BJTs can transfer the unwanted thermal power from the current regulator channel to the BJTs (Figure 15).

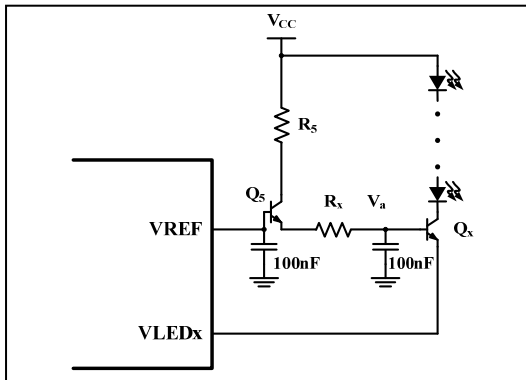

Figure 15 IS31LT3117 with external BJTs

With the external BJTs, the voltage across  $V_{LEDx}$  to GND is given by Equation (3):

$$\begin{aligned} V_{VLEDx} &= V_{REF} - V_{beQ5} - R_x \times I_{beQx} - V_{beQx} \\ &= V_{REF} - V_{beQ5} - R_x \times \frac{I_{SINKx}}{\beta + 1} - V_{beQx} \end{aligned} \quad (3)$$

Where  $V_{beQ5}$  and  $V_{beQx}$  are the base-emitter voltage of  $Q_5$  and  $Q_x$ ,  $I_{beQx}$  is the base-emitter current of  $Q_x$ .  $\beta$  is the gain of BJT.

In order to ensure the normal operation, the voltage across  $V_{LEDx}$  should not be lower than the minimum headroom voltage, minimum  $V_{HD}$  (0.8V). So,

$$V_{REF} - V_{beQ5} - R_x \times \frac{I_{SINKx}}{\beta + 1} - V_{beQx} = V_{HD}$$

Therefore,

$$R_x = \frac{V_{REF} - V_{beQ5} - V_{beQx} - V_{HD}}{\frac{I_{SINKx}}{\beta + 1}} \quad (4)$$

$R_5$  can transfer the unwanted thermal power from  $Q_5$  to itself. Assume the current through  $Q_5$  is  $I_{Q5}$ ,

$$I_{Q5} \approx \sum_{X=1}^4 \frac{I_{SINKx}}{\beta + 1} \quad (5)$$

The power on  $R_5$  can be given by Equation (6):

$$P_{R5} = R_5 \times I_{Q5}^2 \quad (6)$$

The power on  $Q_5$  can be given by Equation (7):

$$P_{Q5} = [V_{CC} - (V_{REF} - V_{beQ5}) - R_5 \times I_{Q5}] \times I_{Q5} \quad (7)$$

An appropriate value of  $R_5$  should be chosen to ensure the power dissipation on  $Q_5$  won't exceed the power rating of  $Q_5$ . If the sum of total power of  $P_{R5}$  and  $P_{Q5}$  is low enough,  $R_5$  can be shorted and all power dissipates on  $Q_5$ .

The power on  $Q_x$  can be calculated by Equation (8):

$$P_{Qx} = (V_{CC} - V_{LEDS} - V_{VLEDx}) \times I_{SINKx} \quad (8)$$

An appropriate value of  $R_x$  should be chosen to ensure the power dissipation on  $Q_x$  won't exceed the power rating of  $Q_x$ .

All of these BJTs should be set to operate in the linear region to ensure normal operation.

For example, assume  $I_{SINKx} = 350\text{mA}$ ,  $V_{CC} = 12\text{V}$ ,  $V_{LEDS}$  of three LEDs is 9.6V, the minimum  $\beta$  of the selected BJT is 200, the maximum base-emitter voltage of  $Q_5$  and  $Q_x$  are all 0.7V, The minimum  $V_{REF}$  pin output voltage is 2.4V, The  $V_{be}$  of BJT is approximately 0.7V.  $R_x$  can be calculated from Equation (4):

$$\begin{aligned} R_x &= \frac{V_{REF} - V_{beQ5} - V_{beQx} - V_{HD}}{\frac{I_{SINKx}}{\beta + 1}} \\ &= \frac{2.4 - 0.7 - 0.7 - 0.8}{\frac{0.35}{200 + 1}} \approx 115\Omega \end{aligned}$$

By Equation (5),

$$I_{Q5} \approx \sum_{X=1}^4 \frac{I_{SINKx}}{\beta + 1} \approx 4 \times \frac{0.35}{200 + 1} \approx 7\text{mA}$$

Therefore,

$$\begin{aligned} P_S &= P_{Q5} + P_{R5} = [V_{CC} - (V_{REF} - V_{beQ5})] \times I_{Q5} \\ &= [12 - (2.4 - 0.7)] \times 0.007 = 0.0721\text{W} \end{aligned}$$

The  $P_S$  is pretty low. So  $R_5$  can be eliminated.

And,

# IS31LT3117

$$P_{Qx} = (V_{CC} - V_{LEDS} - V_{VLEDx}) \times I_{SINKx}$$

$$= (12 - 9.6 - 0.8) \times 0.35 = 0.56W$$

## LED BRIGHTNESS CONTROL

IS31LT3117 allows user to control the LED intensity in two ways. First, the current sink level can be adjusted by changing the external resistance, or by using an external current source on the ISET pin to provide the reference current. However, the spectral output of the LED may shift slightly at different current levels, thus adversely affecting the color temperature of the light output.

IS31LT3117 also provides a PWM input pin to control the ON/OFF state of all four channels. Using a PWM input signal of different duty cycle allows the average LED current to be adjusted linearly and proportional to the duty cycle, while maintaining the same peak current through the LEDs. In this way, the light intensity can be reduced without affecting the spectral content of the light, effectively dimming the light without changing the color temperature.

## TEMPERATURE REGULATION

IS31LT3117 integrates a thermal regulation block which is designed to protect the IC from overheating when dissipating high power. If the junction temperature of the device exceeds 130°C (Typ.), the output current in each channel will begin to reduce linearly at a rate of -2.22% per °C and hence reduce the power dissipation of the IC. If the junction temperature of the IC continues to increase to the point where the thermal shutdown temperature of 160°C is reached or exceeded, the IC will automatically go into shutdown mode in which all of the four channel's sink currents are reduced to a minimum.

If the junction temperature of the device is above 130°C (Typ.), and if thermal shutdown is not initiated, the output current will continue to regulate based on the junction temperature. In the temperature range 130°C < T<sub>J</sub> < 160°C, the output current will regulate based on the following Equation (9):

$$I_{OUT} = \left( \frac{35}{9} - \frac{2}{90} \times T_J \right) \times I_{OUTMAX} \quad (9)$$

When the junction temperature of IS31LT3117 exceeds 160°C (Typ.), the IC will switch all outputs and internal output bias currents are turned off. This reduces the power dissipation of the IC to the minimum, and, under normal conditions, the IC will begin to cool down. After thermal shutdown is initiated, the temperature of the IC must drop below 140°C (Typ.) before returning to normal operation. If thermal shutdown is not initiated, the output current will continue to regulate based on the junction temperature.

The plot below illustrates the simulated output current in the case of increasing temperature and, if thermal shutdown is initiated or the ambient temperature decreases, as a function of percentage of output current programmed value.

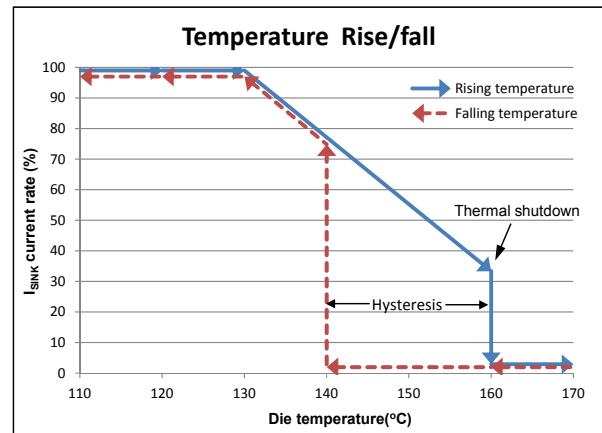

Figure 16 Temperature regulation

Note that because of the test environment, R<sub>θJA</sub> and test method, the output current will be a little different from that of Figure 16. It is recommended a system test to be performed to confirm the details of current changing over the entire operation temperature range.

## THERMAL DISSIPATION

The package thermal resistance, R<sub>θJA</sub>, determines the amount of heat that can pass from the silicon die to the surrounding ambient environment. The R<sub>θJA</sub> is a measure of the temperature rise created by power dissipation and is usually measured in degree Celsius per watt (°C/W). The junction temperature, T<sub>J</sub>, can be calculated by the rise of the silicon temperature, ΔT, the power dissipation, P<sub>D</sub>, and the package thermal resistance, R<sub>θJA</sub>, as in Equation (10):

$$P_D = V_{CC} \times I_{IN} + \sum_{x=1}^4 V_{VLEDx} \times I_{OUTx} \quad (10)$$

and,

$$T_J = T_A + \Delta T = T_A + P_D \times \theta_{JA} \quad (11)$$

Where V<sub>CC</sub> is the supply voltage, V<sub>VLEDx</sub> is the voltage across VLEDx to GND and T<sub>A</sub> is the ambient temperature.

When operating the device at high ambient temperatures, or when driving high load current, care must be taken to avoid exceeding the package power dissipation limits. The maximum power dissipation can be calculated using the following Equation (12):

$$P_{D(MAX)} = \frac{125^\circ C - 25^\circ C}{\theta_{JA}} \quad (12)$$

# IS31LT3117

$$\text{So, } P_{D(MAX)} = \frac{125^{\circ}\text{C} - 25^{\circ}\text{C}}{39.9^{\circ}\text{C/W}} \approx 2.5\text{W}$$

Figure 17, shows the power derating of the IS31LT3117 on a JEDEC boards (in accordance with JESD 51-5 and JESD 51-7) standing in still air.

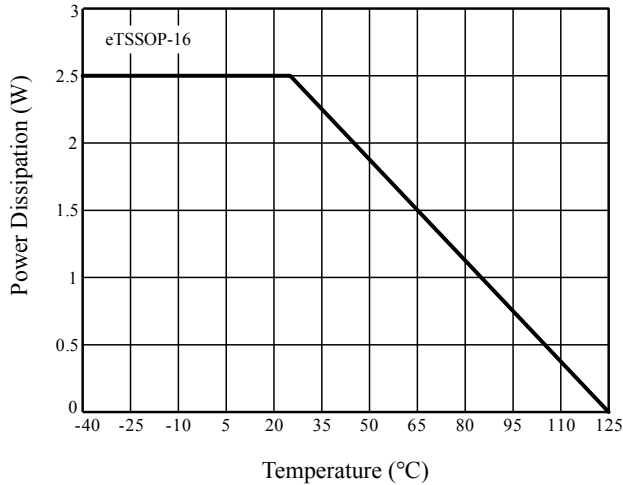

**Figure 17** Dissipation curve

When the junction temperature,  $T_J$ , exceeds the absolute maximum temperature (Typ.  $125^{\circ}\text{C}$ ), external

BJTs should be used to withstand unwanted dissipation.

For example, the maximum  $V_{CC}$  is 24VDC, the minimum  $V_{VLEDx}$  is 22V, the highest ambient temperature is  $40^{\circ}\text{C}$ , and the  $I_{OUTx}$  is 300mA. The power dissipation and the junction temperature can be calculated as:

$$P_D = 24 \times 0.0115 + (24 - 22) \times 0.3 \times 4 = 2.676\text{W}$$

$$T_J = 40 + 2.676 \times 39.9 = 146.8^{\circ}\text{C}$$

$$T_J > 125^{\circ}\text{C}$$

Hence this configuration needs external BJTs.

When designing the Printed Circuit Board (PCB) layout, double-sided PCB with a copper area of a few square millimeters on each side of the board directly under the IS31LT3117 (eTSSOP-16 package) should be used. Multiple thermal vias will help to conduct heat from the exposed pad of the IS31LT3117 to the copper on each side of the board. The thermal resistance can be further reduced by using a metal substrate or by adding a heatsink.

# IS31LT3117

## CLASSIFICATION REFLOW PROFILES

| Profile Feature  | Pb-Free Assembly                 |
|--|----------------------------------|
| Preheat & Soak<br>Temperature min (T <sub>sm</sub> )<br>Temperature max (T <sub>sm</sub> )<br>Time (T <sub>sm</sub> to T <sub>sm</sub> ) (t <sub>s</sub> ) | 150°C<br>200°C<br>60-120 seconds |
| Average ramp-up rate (T <sub>sm</sub> to T <sub>p</sub> )  | 3°C/second max.                  |
| Liquidous temperature (T <sub>L</sub> )<br>Time at liquidous (t <sub>L</sub> )   | 217°C<br>60-150 seconds          |
| Peak package body temperature (T <sub>p</sub> )*   | Max 260°C                        |
| Time (t <sub>p</sub> )** within 5°C of the specified classification temperature (T <sub>c</sub> )  | Max 30 seconds                   |
| Average ramp-down rate (T <sub>p</sub> to T <sub>sm</sub> )  | 6°C/second max.                  |
| Time 25°C to peak temperature  | 8 minutes max.                   |

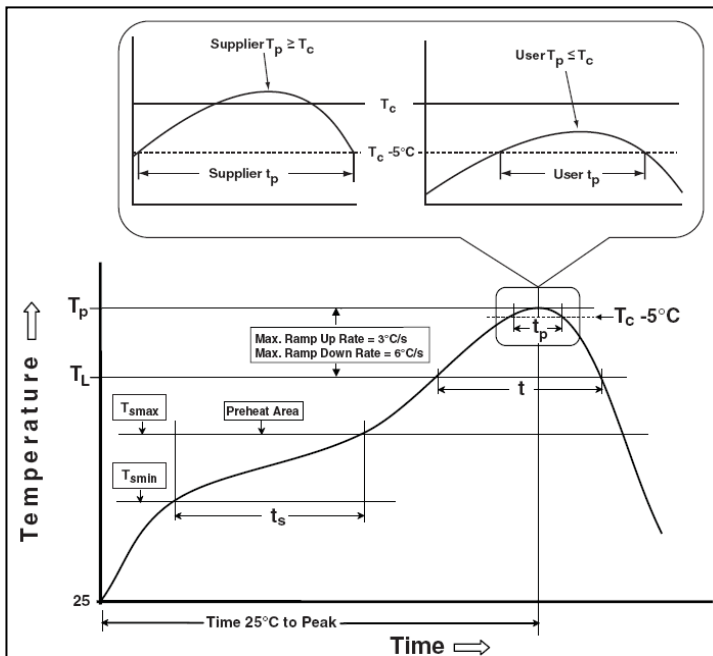
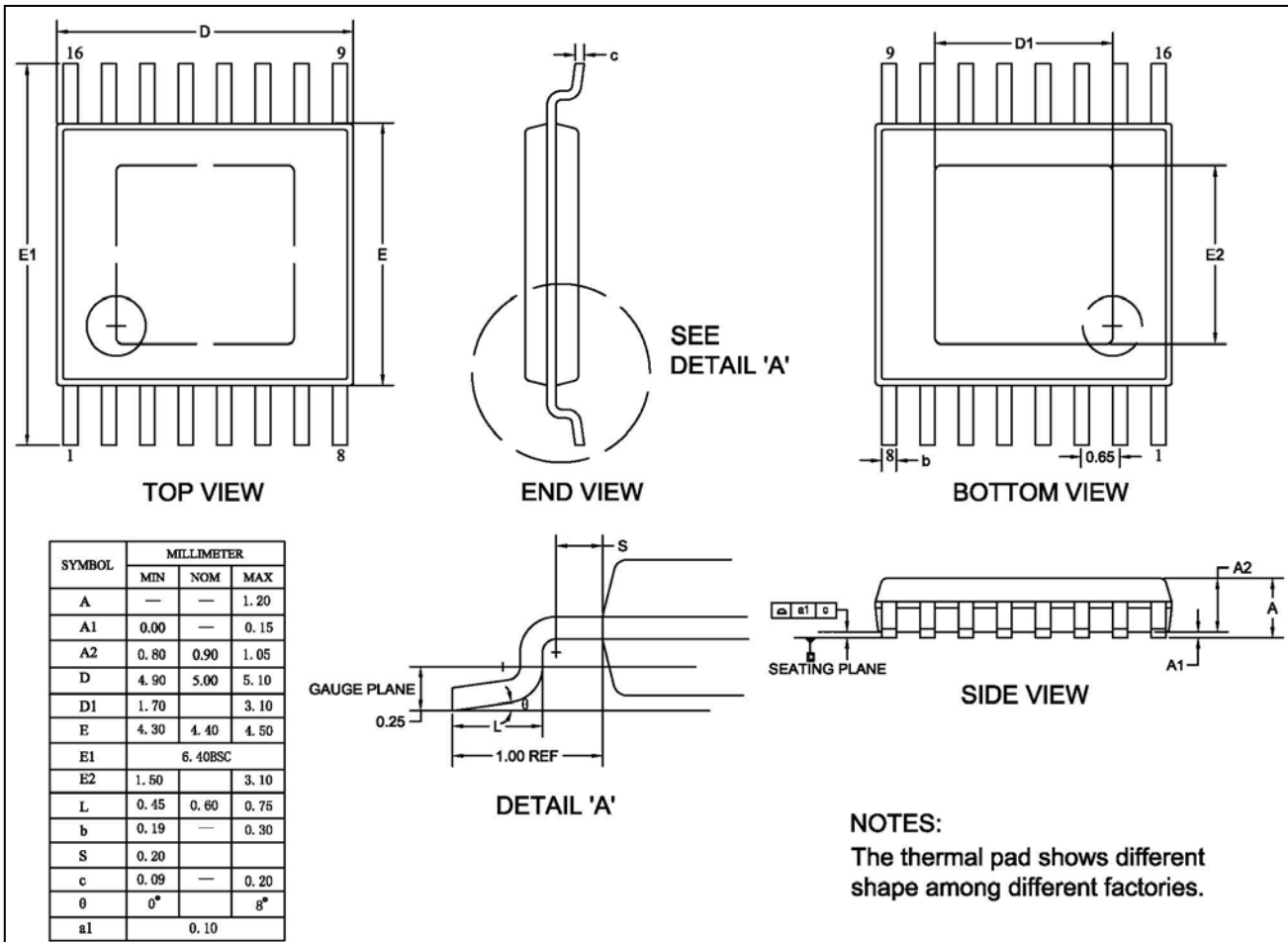

Figure 18 Classification Profile

# IS31LT3117

## PACKAGE INFORMATION

### eTSSOP-16



# IS31LT3117

## LAND PATTERN

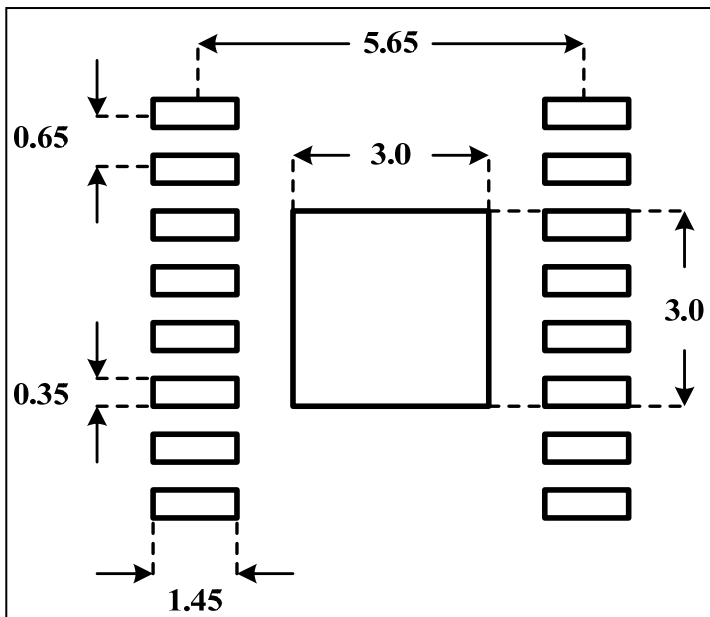

**Note:**

1. Land pattern complies to IPC-7351.
2. All dimensions in MM.



Компания «Океан Электроники» предлагает заключение долгосрочных отношений при поставках импортных электронных компонентов на взаимовыгодных условиях!

Наши преимущества:

- Поставка оригинальных импортных электронных компонентов напрямую с производств Америки, Европы и Азии, а так же с крупнейших складов мира;
- Широкая линейка поставок активных и пассивных импортных электронных компонентов (более 30 млн. наименований);
- Поставка сложных, дефицитных, либо снятых с производства позиций;
- Оперативные сроки поставки под заказ (от 5 рабочих дней);
- Экспресс доставка в любую точку России;
- Помощь Конструкторского Отдела и консультации квалифицированных инженеров;
- Техническая поддержка проекта, помощь в подборе аналогов, поставка прототипов;
- Поставка электронных компонентов под контролем ВП;
- Система менеджмента качества сертифицирована по Международному стандарту ISO 9001;
- При необходимости вся продукция военного и аэрокосмического назначения проходит испытания и сертификацию в лаборатории (по согласованию с заказчиком);
- Поставка специализированных компонентов военного и аэрокосмического уровня качества (Xilinx, Altera, Analog Devices, Intersil, Interpoint, Microsemi, Actel, Aeroflex, Peregrine, VPT, Syfer, Eurofarad, Texas Instruments, MS Kennedy, Miteq, Cobham, E2V, MA-COM, Hittite, Mini-Circuits, General Dynamics и др.);

Компания «Океан Электроники» является официальным дистрибьютором и эксклюзивным представителем в России одного из крупнейших производителей разъемов военного и аэрокосмического назначения «JONHON», а так же официальным дистрибьютором и эксклюзивным представителем в России производителя высокотехнологичных и надежных решений для передачи СВЧ сигналов «FORSTAR».



## JONHON

«JONHON» (основан в 1970 г.)

Разъемы специального, военного и аэрокосмического назначения:

(Применяются в военной, авиационной, аэрокосмической, морской, железнодорожной, горно- и нефтедобывающей отраслях промышленности)

«FORSTAR» (основан в 1998 г.)

ВЧ соединители, коаксиальные кабели,  
кабельные сборки и микроволновые компоненты:

(Применяются в телекоммуникациях гражданского и специального назначения, в средствах связи, РЛС, а так же военной, авиационной и аэрокосмической отраслях промышленности).



Телефон: 8 (812) 309-75-97 (многоканальный)

Факс: 8 (812) 320-03-32

Электронная почта: [ocean@oceanchips.ru](mailto:ocean@oceanchips.ru)

Web: <http://oceanchips.ru/>

Адрес: 198099, г. Санкт-Петербург, ул. Калинина, д. 2, корп. 4, лит. А