

## GENERAL DESCRIPTION

The XR21V1414 (V1414) is an enhanced 4-channel USB Universal Asynchronous Receiver and Transmitter (UART). The USB interface is fully compliant to Full Speed USB 2.0 specification that supports 12 Mbps USB data transfer rate. The USB interface also supports USB suspend, resume and remote wakeup operations.

The V1414 operates from an internal 48MHz clock therefore no external crystal/oscillator is required like previous generation UARTs. With the fractional baud rate generator, any baud rate can accurately be generated using the internal 48MHz clock.

The large 128-byte TX FIFO and 384-byte RX FIFO of the V1414 helps to optimize the overall data throughput for various applications. If required, the multidrop mode and automatic RS-485 half-duplex direction control feature further simplifies typical multidrop RS-485 applications.

The V1414 operates from a single 2.97 to 3.63 volt power supply and has 5V tolerant inputs. The V1414 is available in a 48-pin TQFP package.

WHQL certified software drivers for Windows 2000, XP, Vista, 7, 8, and CE, as well as Linux and Mac are supported for the XR21V1414.

## APPLICATIONS

- Portable Appliances
- External Converters (dongles)
- Battery-Operated Devices
- Cellular Data Devices
- Factory Automation and Process Controls
- Industrial applications

## FEATURES

- USB 2.0 Compliant, Full-speed (12 Mbps)
  - Supports USB suspend, resume and remote wakeup operations
- $\pm 5$  kV HBM ESD protection on USB data pins
- $\pm 2$  kV HBM ESD protection on all other pins
- Enhanced Features of each UART
  - UART data rates up to 12 Mbps
  - Fractional Baud Rate Generator
  - 128 byte TX FIFO
  - 384 byte RX FIFO
  - 7, 8 or 9 data bits
  - 1 or 2 stop bits
  - Odd, even, mark, space, or no parity
  - Automatic Hardware (RTS/CTS or DTR/DSR) Flow Control
  - Automatic Software (Xon/Xoff) Flow Control
  - Multidrop mode
  - Auto RS-485 Half-Duplex Control
  - Half-Duplex mode
  - Selectable GPIO or Modem I/O
- Internal 48 MHz clock
- Single 3.3V power supply
- 5V tolerant inputs
- 48-pin TQFP package
- Virtual COM Port WHQL certified drivers
  - Windows 2000, XP Vista, Win7 and Win8
  - Windows CE 4.2, 5.0, 6.0, 7.0
  - Linux
  - Mac

**FIGURE 1. XR21V1414 BLOCK DIAGRAM**

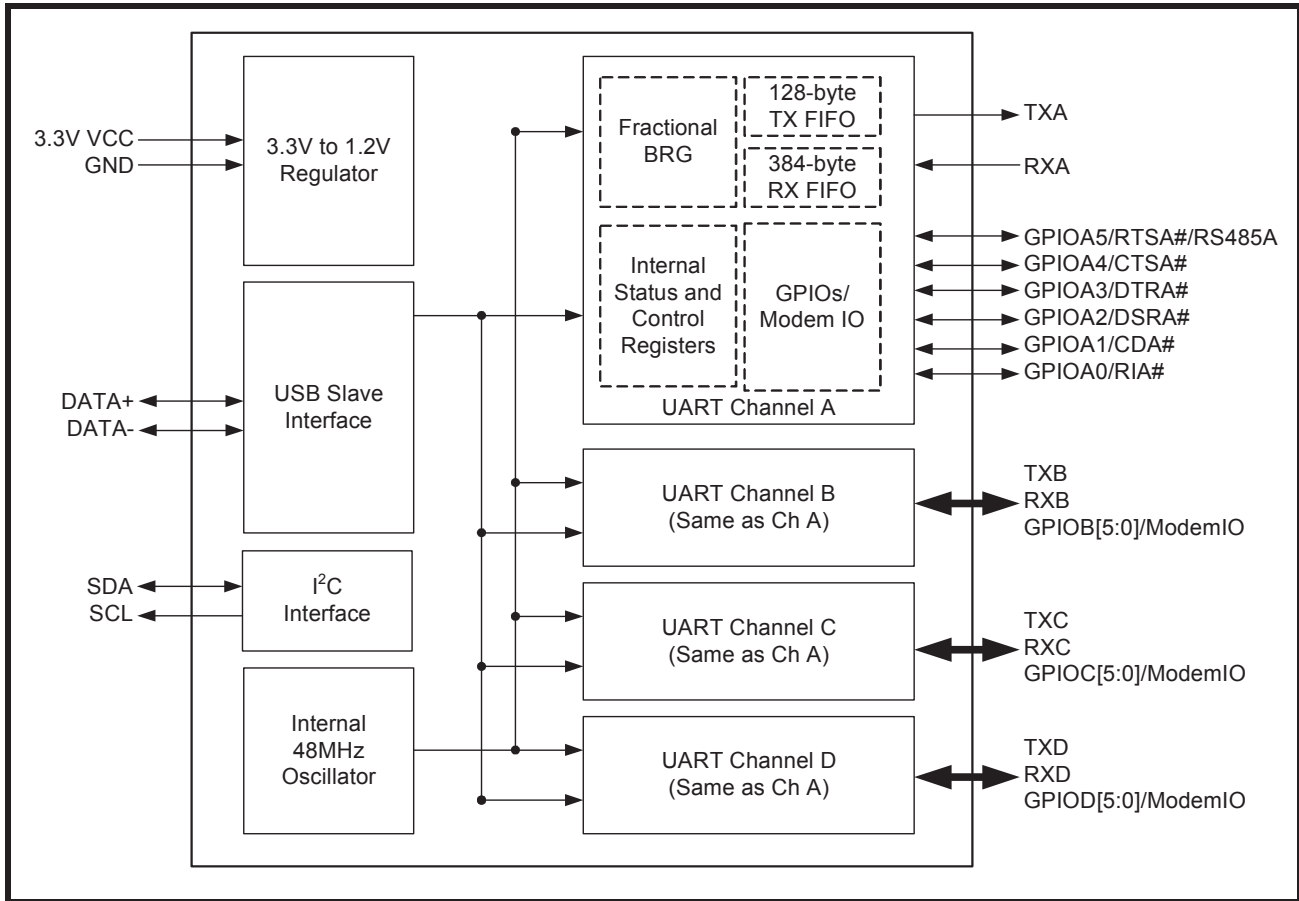
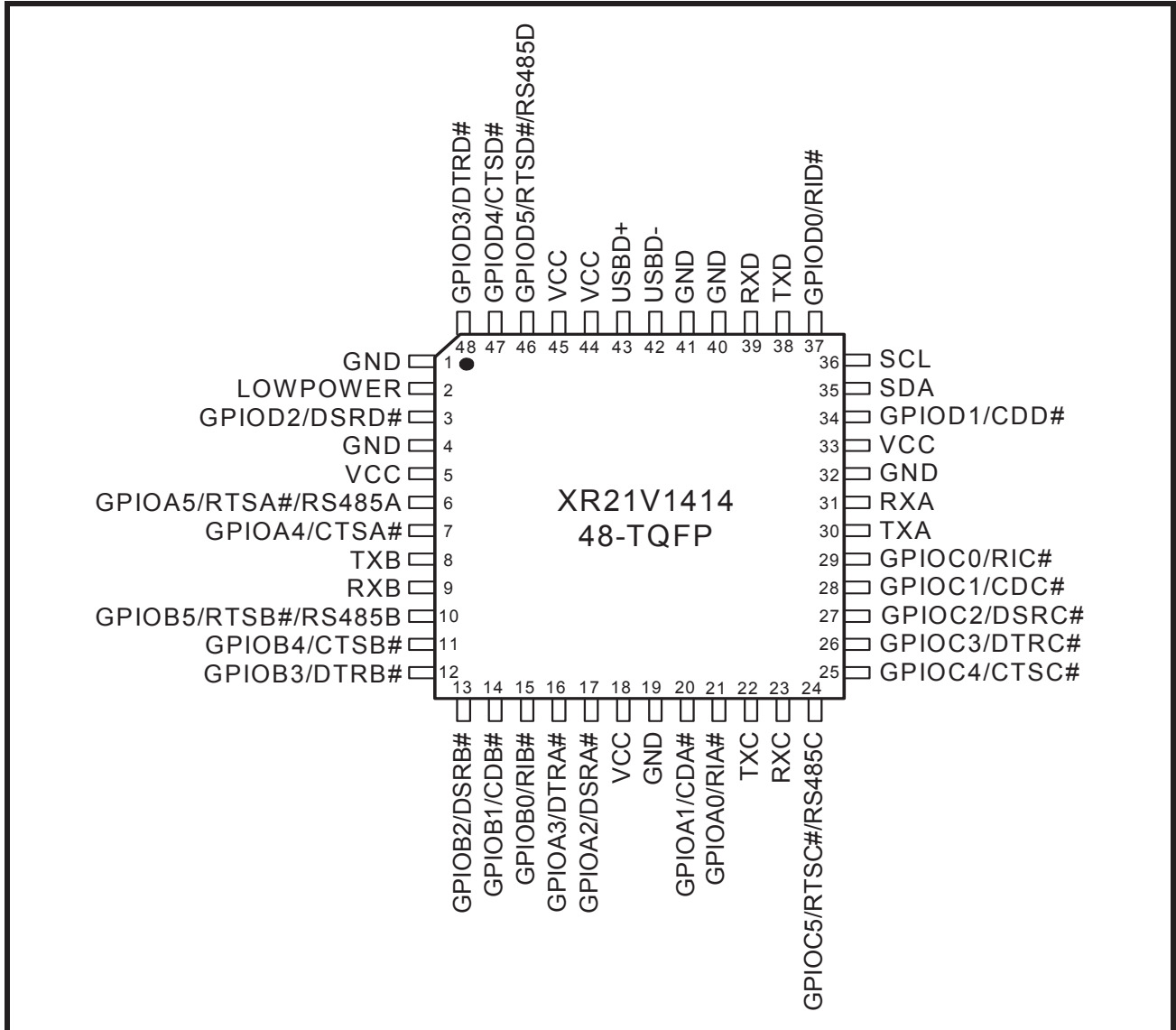

FIGURE 2. PIN OUT ASSIGNMENT



**ORDERING INFORMATION**

PART NUMBER	PACKAGE	OPERATING TEMPERATURE RANGE	DEVICE STATUS
XR21V1414IM48-F	48-pin TQFP	-40°C to +85°C	Active
XR21V1414IM48TR-F	48-pin TQFP	-40°C to +85°C	Active

NOTE: TR = Tape and Reel, F = Green / RoHS

## PIN DESCRIPTIONS

## Pin Description

NAME	48-QFN PIN #	TYPE	DESCRIPTION
<b>UART Channel A Signals</b>			
RXA	31	I	UART Channel A Receive Data or IR Receive Data. This pin has an internal pull-up resistor. Internal pull-up resistor is <u>not</u> disabled during suspend mode.
TXA	30	O	UART Channel A Transmit Data or IR Transmit Data.
GPIOA0/RIA#/ RWKA#	21	I/O	UART Channel A general purpose I/O or UART Ring-Indicator input (active low) or Remote Wakeup Input ( <a href="#">See "Section 1.5.12, USB Suspend" on page 14.</a> ). This pin has an internal pull-up resistor which is disabled during suspend mode. If using this GPIO as an input, an external pull-up resistor is required to minimize the power consumption in the suspend mode.
GPIOA1/CDA#	20	I/O	UART Channel A general purpose I/O or UART Carrier-Detect input (active low). This pin has an internal pull-up resistor which is disabled during suspend mode. If using this GPIO as an input, an external pull-up resistor is required to minimize the power consumption in the suspend mode.
GPIOA2/DSRA#	17	I/O	UART Channel A general purpose I/O or UART Data-Set-Ready input (active low). <a href="#">See "Section 1.5.6, Automatic DTR/DSR Hardware Flow Control" on page 13.</a> This pin has an internal pull-up resistor which is disabled during suspend mode. If using this GPIO as an input, an external pull-up resistor is required to minimize the power consumption in the suspend mode.
GPIOA3/DTRA#	16	I/O	UART Channel A general purpose I/O or UART Data-Terminal-Ready output (active low). <a href="#">See "Section 1.5.6, Automatic DTR/DSR Hardware Flow Control" on page 13.</a> This pin has an internal pull-up resistor which is disabled during suspend mode. If using this GPIO as an input, an external pull-up resistor is required to minimize the power consumption in the suspend mode.
GPIOA4/CTSA#	7	I/O	UART Channel A general purpose I/O or UART Clear-to-Send input (active low). <a href="#">See "Section 1.5.5, Automatic RTS/CTS Hardware Flow Control" on page 13.</a> This pin has an internal pull-up resistor which is disabled during suspend mode. If using this GPIO as an input, an external pull-up resistor is required to minimize the power consumption in the suspend mode.
GPIOA5/RTSA#/ RS485A	6	I/O	UART Channel A general purpose I/O or UART Request-to-Send output (active low) or auto RS-485 half-duplex control. <a href="#">See "Section 1.5.5, Automatic RTS/CTS Hardware Flow Control" on page 13.</a> This pin has an internal pull-up resistor which is disabled during suspend mode. If using this GPIO as an input, an external pull-up resistor is required to minimize the power consumption in the suspend mode.
<b>UART Channel B Signals</b>			
RXB	9	I	UART Channel B Receive Data or IR Receive Data. This pin has an internal pull-up resistor. Internal pull-up resistor is <u>not</u> disabled during suspend mode.



Pin Description

NAME	48-QFN PIN #	TYPE	DESCRIPTION
TXB	8	O	UART Channel B Transmit Data or IR Transmit Data.
GPIOB0/RIB#/ RWKB#	15	I/O	UART Channel B general purpose I/O or UART Ring-Indicator input (active low) or Remote Wakeup Input ( <b>See "Section 1.5.12, USB Suspend" on page 14.</b> ). This pin has an internal pull-up resistor which is disabled during suspend mode. If using this GPIO as an input, an external pull-up resistor is required to minimize the power consumption in the suspend mode.
GPIOB1/CDB#	14	I/O	UART Channel B general purpose I/O or UART Carrier-Detect input (active low). This pin has an internal pull-up resistor which is disabled during suspend mode. If using this GPIO as an input, an external pull-up resistor is required to minimize the power consumption in the suspend mode.
GPIOB2/DSRB#	13	I/O	UART Channel B general purpose I/O or UART Data-Set-Ready input (active low). <b>See "Section 1.5.6, Automatic DTR/DSR Hardware Flow Control" on page 13.</b> This pin has an internal pull-up resistor which is disabled during suspend mode. If using this GPIO as an input, an external pull-up resistor is required to minimize the power consumption in the suspend mode.
GPIOB3/DTRB#	12	I/O	UART Channel B general purpose I/O or UART Data-Terminal-Ready output (active low). <b>See "Section 1.5.6, Automatic DTR/DSR Hardware Flow Control" on page 13.</b> This pin has an internal pull-up resistor which is disabled during suspend mode. If using this GPIO as an input, an external pull-up resistor is required to minimize the power consumption in the suspend mode.
GPIOB4/CTSB#	11	I/O	UART Channel B general purpose I/O or UART Clear-to-Send input (active low). <b>See "Section 1.5.5, Automatic RTS/CTS Hardware Flow Control" on page 13.</b> This pin has an internal pull-up resistor which is disabled during suspend mode. If using this GPIO as an input, an external pull-up resistor is required to minimize the power consumption in the suspend mode.
GPIOB5/RTSB#/ RS485B	10	I/O	UART Channel B general purpose I/O or UART Request-to-Send output (active low) or auto RS-485 half-duplex control. <b>See "Section 1.5.5, Automatic RTS/CTS Hardware Flow Control" on page 13.</b> This pin has an internal pull-up resistor which is disabled during suspend mode. If using this GPIO as an input, an external pull-up resistor is required to minimize the power consumption in the suspend mode.
<b>UART Channel C Signals</b>			
RXC	23	I	UART Channel C Receive Data or IR Receive Data. This pin has an internal pull-up resistor. Internal pull-up resistor is <u>not</u> disabled during suspend mode.
TXC	22	O	UART Channel C Transmit Data or IR Transmit Data.
GPIOC0/RIC#/ RWKC#	29	I/O	UART Channel C general purpose I/O or UART Ring-Indicator input (active low) or Remote Wakeup Input ( <b>See "Section 1.5.12, USB Suspend" on page 14.</b> ). This pin has an internal pull-up resistor which is disabled during suspend mode. If using this GPIO as an input, an external pull-up resistor is required to minimize the power consumption in the suspend mode.

## Pin Description

NAME	48-QFN PIN #	TYPE	DESCRIPTION
GPIOC1/CDC#	28	I/O	UART Channel C general purpose I/O or UART Carrier-Detect input (active low). This pin has an internal pull-up resistor which is disabled during suspend mode. If using this GPIO as an input, an external pull-up resistor is required to minimize the power consumption in the suspend mode.
GPIOC2/DSRC#	27	I/O	UART Channel C general purpose I/O or UART Data-Set-Ready input (active low). <b>See "Section 1.5.6, Automatic DTR/DSR Hardware Flow Control" on page 13.</b> This pin has an internal pull-up resistor which is disabled during suspend mode. If using this GPIO as an input, an external pull-up resistor is required to minimize the power consumption in the suspend mode.
GPIOC3/DTRC#	26	I/O	UART Channel C general purpose I/O or UART Data-Terminal-Ready output (active low). <b>See "Section 1.5.6, Automatic DTR/DSR Hardware Flow Control" on page 13.</b> This pin has an internal pull-up resistor which is disabled during suspend mode. If using this GPIO as an input, an external pull-up resistor is required to minimize the power consumption in the suspend mode.
GPIOC4/CTSC#	25	I/O	UART Channel C general purpose I/O or UART Clear-to-Send input (active low). <b>See "Section 1.5.5, Automatic RTS/CTS Hardware Flow Control" on page 13.</b> This pin has an internal pull-up resistor which is disabled during suspend mode. If using this GPIO as an input, an external pull-up resistor is required to minimize the power consumption in the suspend mode.
GPIOC5/RTSC#/ RS485C	24	I/O	UART Channel C general purpose I/O or UART Request-to-Send output (active low) or auto RS-485 half-duplex control. <b>See "Section 1.5.5, Automatic RTS/CTS Hardware Flow Control" on page 13.</b> This pin has an internal pull-up resistor which is disabled during suspend mode. If using this GPIO as an input, an external pull-up resistor is required to minimize the power consumption in the suspend mode.
<b>UART Channel D Signals</b>			
RXD	39	I	UART Channel D Receive Data or IR Receive Data. This pin has an internal pull-up resistor. Internal pull-up resistor is <u>not</u> disabled during suspend mode.
TXD	38	O	UART Channel D Transmit Data or IR Transmit Data.
GPIOD0/RID#/ RWKD#	37	I/O	UART Channel D general purpose I/O or UART Ring-Indicator input (active low) or Remote Wakeup Input ( <b>See "Section 1.5.12, USB Suspend" on page 14.</b> ). This pin has an internal pull-up resistor which is disabled during suspend mode. If using this GPIO as an input, an external pull-up resistor is required to minimize the power consumption in the suspend mode.
GPIOD1/CDD#	34	I/O	UART Channel D general purpose I/O or UART Carrier-Detect input (active low). This pin has an internal pull-up resistor which is disabled during suspend mode. If using this GPIO as an input, an external pull-up resistor is required to minimize the power consumption in the suspend mode.



Pin Description

NAME	48-QFN PIN #	TYPE	DESCRIPTION
GPIOD2/DSRD#	3	I/O	UART Channel D general purpose I/O or UART Data-Set-Ready input (active low). See "Section 1.5.6, Automatic DTR/DSR Hardware Flow Control" on page 13. This pin has an internal pull-up resistor which is disabled during suspend mode. If using this GPIO as an input, an external pull-up resistor is required to minimize the power consumption in the suspend mode.
GPIOD3/DTRD#	48	I/O	UART Channel D general purpose I/O or UART Data-Terminal-Ready output (active low). See "Section 1.5.6, Automatic DTR/DSR Hardware Flow Control" on page 13. This pin has an internal pull-up resistor which is disabled during suspend mode. If using this GPIO as an input, an external pull-up resistor is required to minimize the power consumption in the suspend mode.
GPIOD4/CTSD#	47	I/O	UART Channel D general purpose I/O or UART Clear-to-Send input (active low). See "Section 1.5.5, Automatic RTS/CTS Hardware Flow Control" on page 13. This pin has an internal pull-up resistor which is disabled during suspend mode. If using this GPIO as an input, an external pull-up resistor is required to minimize the power consumption in the suspend mode.
GPIOD5/RTSD#/ RS485D	46	I/O	UART Channel D general purpose I/O or UART Request-to-Send output (active low) or auto RS-485 half-duplex control. See "Section 1.5.5, Automatic RTS/CTS Hardware Flow Control" on page 13. This pin has an internal pull-up resistor which is disabled during suspend mode. If using this GPIO as an input, an external pull-up resistor is required to minimize the power consumption in the suspend mode.
<b>USB Interface Signals</b>			
USB D+	43	I/O	USB port differential data plus. This pin has a 1.5 K Ohm internal pull-up resistor.
USB D-	42	I/O	USB port differential data minus.
<b>I2C Interface Signals</b>			
SDA	35	I/O OD	I <sup>2</sup> C-controller data input/output (open-drain). An optional external I <sup>2</sup> C EEPROM can be used to store default configurations upon power-up including the USB Vendor ID and Device ID. See Table 3. A pull-up resistor (typically 4.7 to 10k Ohms) is required.  If an EEPROM is not used, this pin can be used with the SCL pin to select the Remote Wake-up and Power modes. An external pull-up or pull-down resistor is required. See Table 2.
SCL	36	I/O OD	I <sup>2</sup> C-controller serial input clock. An optional external I <sup>2</sup> C EEPROM can be used to store default configurations upon power-up including the USB Vendor ID and Device ID. See Table 3. A pull-up resistor (typically 4.7 to 10k Ohms) is required.  If an EEPROM is not used, this pin can be used with the SDA pin to select the Remote Wake-up and Power modes. An external pull-up or pull-down resistor is required. See Table 2.

## Pin Description

NAME	48-QFN PIN #	TYPE	DESCRIPTION
<b>Miscellaneous Signals</b>			
LOWPOWER	2	O	<p>Low power status output. The LOWPOWER pin will be asserted whenever it is not safe to draw the amount of current from VBUS power requested in the Device Max Power field of the Configuration Descriptor. The LOWPOWER pin will behave differently for a low power device and a high power device.</p> <ul style="list-style-type: none"> <li>• Low-power device (<math>\leq 1</math> unit load or 100 mA i.e. <math>bMaxPower \leq 0x32</math>): LOWPOWER pin is asserted when the USB UART is in suspend mode.</li> <li>• High-power device (<math>bMaxPower &gt; 0x32</math>): LOWPOWER pin is asserted when the USB UART is in suspend mode or when it is not yet configured.</li> </ul> <p>The LOWPOWER pin will be de-asserted whenever it is safe to draw the amount of current requested in the Device Maximum Power field. This pin is sampled momentarily at power-up or at any USB bus reset to configure the polarity of the LOWPOWER output during suspend mode. An external (10K) pull-up resistor will cause the LOWPOWER pin to be asserted HIGH during suspend mode. An external (3.3K) pull-down resistor will cause the LOWPOWER pin to be asserted LOW during suspend mode.</p>
<b>Power / Ground Signals</b>			
VCC	5, 18, 33, 44, 45	Pwr	+3.3V power supply.
GND	1, 4, 19, 32, 40, 41	Pwr	Power supply common, ground.

**NOTE:** Pin type: I=Input, O=Output, I/O= Input/output, OD=Output Open Drain.



## 1.0 FUNCTIONAL DESCRIPTIONS

### 1.1 USB interface

The USB interface of the V1414 is compliant with the USB 2.0 Full-Speed Specifications. The USB configuration model presented by the V1414 to the device driver is compatible to the Abstract Control Model of the USB Communication Device Class (CDC-ACM). The V1414 uses the following set of parameters:

- 1 Control Endpoint
  - Endpoint 0 as outlined in the USB specifications
- 1 Configuration is supported
- 2 interfaces per UART channel
  - Each UART channel has a single interrupt endpoint
  - Each UART channel have bulk-in and bulk-out endpoints

#### 1.1.1 USB Vendor ID

Exar's USB Vendor ID is 0x04E2. This is the default Vendor ID that is used for the V1414 unless a valid EEPROM is present on the I2C interface signals. If a valid EEPROM is present, the Vendor ID from the EEPROM will be used.

#### 1.1.2 USB Product ID

The default USB Product ID for the V1414 is 0x1414. If a valid EEPROM is present, the Product ID from the EEPROM will be used. Note that Exar's custom drivers for all Windows OS require that the Product ID be an even number for the V1414 device for proper identification of the device.

### 1.2 USB Device Driver

The V1414 device can be used with either a standard CDC-ACM driver or a custom driver. When the CDC-ACM driver is used, the driver has no capability to read or write the V1414 device registers. Because of this, the V1414 device is initialized to the settings in **Table 1**. With a custom driver, all GPIOs default in hardware to inputs but these settings may be modified by the custom driver.

**TABLE 1: V1414 REGISTER DEFAULTS WITH CDC-ACM DRIVER**

REGISTER	VALUE	NOTES
FLOW_CONTROL	0x01	Hardware flow control
GPIO_MODE	0x01	RTS / CTS flow control
GPIO_DIRECTION	0x08	GPIO3/DTR# configured as an output
GPIO_INT_MASK	0x30	GPIO0/RI#, GPIO1/CD# and GPIO2/DSR# are interrupt sensitive, i.e. can cause a USB interrupt to be generated

Note that when using a CDC-ACM driver, the V1414 will automatically change the bMaxPacketSize to 63 bytes to compensate for a known issue with the Microsoft CDC-ACM device driver. A register is available to change this setting with a custom driver as well. See **“Section 3.4.1, CUSTOM Register Description (Read/Write)” on page 28**. Although there is no ability to read / write registers when using the CDC-ACM driver, basic UART functions, including setting baud rate, character format and sending line break are supported by the CDC driver. Refer to the 4 CDC\_ACM\_IF USB Control Commands listed in **Table 4, “Supported USB Control Commands,” on page 16**.

### 1.3 I<sup>2</sup>C Interface

The I<sup>2</sup>C interface provides connectivity to an external I<sup>2</sup>C memory device (i.e. EEPROM) that can be read by the V1414 for configuration.

The SDA and SCL are used to specify whether Remote Wakeup and/or Bus Powered configurations are to be supported. These pins are sampled at power-up. The following table describes how Remote Wakeup and Bus Powered support.

**TABLE 2: REMOTE WAKEUP AND POWER MODES**

SDA	SCL	REMOTE WAKE-UP SUPPORT	POWER MODE
1	1	No	Self-Powered
1	0	No	Bus-Powered
0	1	Yes	Self-Powered
0	0	Yes	Bus-Powered

#### 1.3.1 EEPROM Contents

If SDA and SCL are both logic '1', the V1414 device will first confirm if there is an external EEPROM attached by attempting to read the first 8 locations of the ROM. If address 0x07 of the ROM contains the value 0x58 (as specified in [Table 3](#)), the contents of the ROM are assumed to be valid. Otherwise the EEPROM will be ignored and the SDA / SCL bits are used to indicate remote wakeup support and device power mode.

The I<sup>2</sup>C address must be 0xA0. An EEPROM can be used to override default Vendor IDs and Device IDs, as well as other attributes and maximum power consumption. Exar provides an in-circuit EEPROM programming utility through the USB interface using UART Control block 0x65. Refer to [Table 5, "Control Blocks," on page 17](#). The EEPROM programming utility can be downloaded from the Exar website. These values are uploaded from the EEPROM to the corresponding USB Standard Device Descriptor or Standard Configuration Descriptor. For details of the USB Descriptors, refer to the USB 2.0 specifications.

**TABLE 3: EEPROM CONTENTS**

EEPROM ADDRESS	CONTENTS
0	Vendor ID (LSB)
1	Vendor ID (MSB)
2	Product ID (LSB)
3	Product ID (MSB)
4	Device Attributes
5	Device Maximum Power
6	Reserved
7	Signature of 0x58 ('X'). If the signature is not correct, the contents of the EEPROM are ignored.

##### 1.3.1.1 Vendor ID

The Vendor ID value replaces the idVendor field in the USB Standard Device Descriptor.

##### 1.3.1.2 Product ID

The Product ID value replaces the idProduct field in the USB Standard Device Descriptor.

### 1.3.1.3 Device Attributes

The Device Attributes value replaces the `bmAttributes` field in the USB Standard Configuration Descriptor. The default setting in the V1414 device is 0xA0. The bit field definitions are:

- Bit 7 is reserved - set to '1'
- Bit 6 is Self-powered mode - set to '0' for bus-powered, set to '1' for self-powered
- Bit 5 is Remote Wakeup support - set to '0' for no support, set to '1' for remote wakeup support
- Bit 4:0 are reserved - set to '0'

### 1.3.1.4 Device Maximum Power

The Device Maximum Power value replaces the `bMaxPower` field in the USB Standard Configuration Descriptor. The value specified is in units of 2 mA. For example, the value 0x2F is decimal 47 or 94 mA. Note that the default `bMaxPower` of the V1414 device is 94 mA.

## 1.4 UART Manager

The UART Manager enables/disables each UART including the TX and RX FIFOs for each UART. The UART Manager is located in a separate register block from the 4 UART channels.

## 1.5 UART

There are 4 enhanced UART channels in the V1414. Each UART channel is independent, therefore, they will need to be initialized and configured independently. Each UART can be configured via USB control transfers from the USB host. At power-up, the V1414 will default to 9600 bps, 8 data bits, no parity bit, 1 stop bit, and no flow control. If a standard CDC driver accesses the V1414, defaults will change. See "Section 1.2, USB Device Driver" on page 9.

### 1.5.1 Transmitter

The transmitter consists of a 128-byte TX FIFO and a Transmit Shift Register (TSR). Once a bulk-out packet has been received and the CRC has been validated, the data bytes in that packet are written into the TX FIFO of the specified UART channel. Data from the TX FIFO is transferred to the TSR when the TSR is idle or has completed sending the previous data byte. The TSR shifts the data out onto the TX output pin at the data rate defined by the `CLOCK_DIVISOR` and `TX_CLOCK_MASK` registers. The transmitter sends the start bit followed by the data bits (starting with the LSB), inserts the proper parity-bit if enabled, and adds the stop-bit(s). The transmitter can be configured for 7 or 8 data bits with or without parity or 9 data bits without parity. If 9 bit data is selected without wide mode, the 9th bit will always be '0'.

#### 1.5.1.1 Wide Mode Transmit

When both 9 bit data and wide mode are enabled, two bytes of data must be written. The first byte that is loaded into the TX FIFO are the first 8 bits (data bits 7-0) of the 9-bit data. Bit-0 of the second byte that is loaded into the TX FIFO is bit-8 of the 9-bit data. The data that is transmitted on the TX pin is as follows: start bit, 9-bit data, stop bit. Use the `WIDE_MODE` register to enable wide mode.

### 1.5.2 Receiver

The receiver consists of a 384-byte RX FIFO and a Receive Shift Register (RSR). Data that is received in the RSR via the RX pin is transferred into the RX FIFO. Data from the RX FIFO is transferred to the USB host in response to a Bulk-In request. Depending on the mode, error / status information for that data character may or may not be stored in the RX FIFO with the data.

#### 1.5.2.1 Normal receive operation with 7 or 8-bit data

Data that is received is stored in the RX FIFO. Any parity, framing or overrun error or break status information related to the data is discarded. Receive data format is shown in Figure 3.

#### 1.5.2.2 Normal receive operation with 9-bit data

The first 8 bits of data received is stored in the RX FIFO. The 9th bit as well as any parity, framing or overrun error or break status information related to the data is discarded.

---

FIGURE 3. NORMAL OPERATION RECEIVE DATA FORMAT



**1.5.2.3 Wide mode receive operation with 7 or 8-bit data**

Two bytes of data are loaded into the RX FIFO for each byte of data received. The first byte is the received data. The second byte consists of the error bits and break status. Wide mode receive data format is shown in Figure 4.

**1.5.2.4 Wide mode receive operation with 9-bit data**

Two bytes of data are loaded into the RX FIFO for each byte of data received. The first byte is the first 8 bits of the received data. The 9th bit received is stored in the bit 0 of the second byte. The parity bit is not received / checked. The remainder of the 2nd byte consists of the framing and overrun error bits and break status.

FIGURE 4. WIDE MODE RECEIVE DATA FORMAT

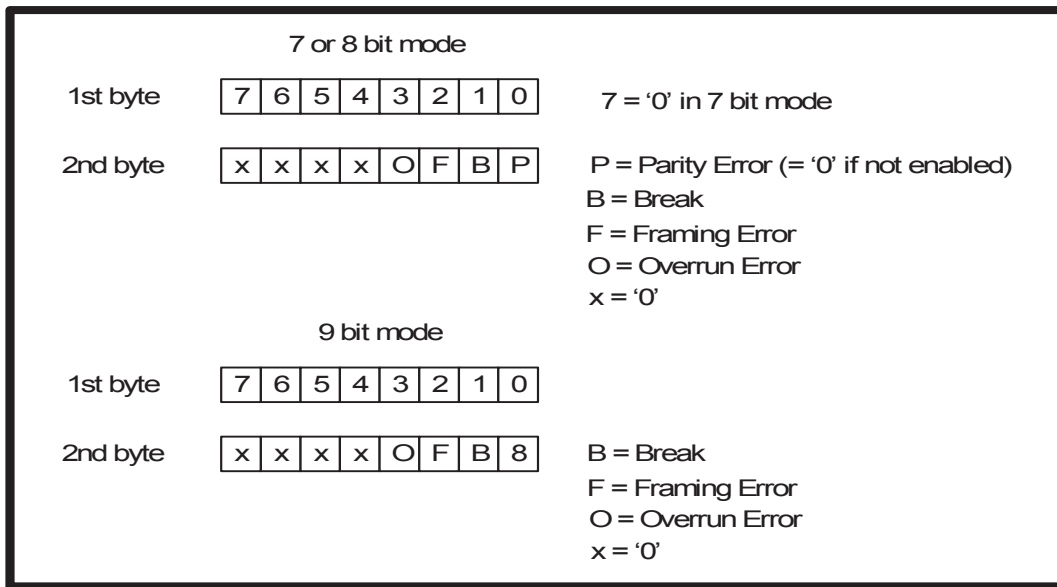

Error flags are also available from the ERROR\_STATUS register and the interrupt packet, however these flags are historical flags indicating that an error has occurred since the previous request. Therefore, no conclusion can be drawn as to which specific byte(s) may have contained an actual error in this manner.

**1.5.3 Rx FIFO Low Latency**

In normal operation all bulk-in transfers will be of maxPacketSize (64) bytes to improve throughput and to minimize host processing. When there are 64 bytes of data in the RX FIFO, the V1414 will acknowledge a bulk-in request from the host and transfer the data packet. If there is less than 64 bytes in the RX FIFO, the V1414 may NAK the bulk-in request indicating that data is not ready to transfer at that time. However, if there is less than 64 bytes in the RX FIFO and no data has been received for more than 3 character times, the V1414 will acknowledge the bulk-in request and transfer any data in the RX FIFO to the USB host.

In some cases, especially when the baud rate is low, this increases latency unacceptably. The V1414 has a low latency register bit that will cause the V1414 to immediately transfer any received data in the RX FIFO to the USB host, i.e. it will not wait for 3 character times. The custom driver can automatically set the

RX\_FIFO\_LOW\_LATENCY register bit to force the V1414 to be in the low latency mode, or the user may manually set this bit. With the CDC-ACM driver, the low latency mode is automatically set whenever the baud rate is set to a value of less than 46921 bps using the CDC\_ACM\_IF\_SET\_LINE\_CODING command.

### 1.5.4 GPIO

Each UART has 6 GPIOs. By hardware default the GPIOs are configured as inputs but may be modified by a custom driver. Additionally, there are several modes that can be enabled to add additional feature such as auto RTS/CTS flow control, auto DTR/DSR flow control or auto RS-485 half duplex control. See [Table 14](#).

### 1.5.5 Automatic RTS/CTS Hardware Flow Control

GPIO5 and GPIO4 of the UART channel can be enabled as the RTS# and CTS# signals for Auto RTS/CTS flow control when GPIO\_MODE[2:0] = '001' and FLOW\_CONTROL[2:0] = '001'. Automatic RTS flow control is used to prevent data overrun errors in local RX FIFO by de-asserting the RTS signal to the remote UART. When there is room in the RX FIFO, the RTS pin will be re-asserted. Automatic CTS flow control is used to prevent data overrun to the remote RX FIFO. The CTS# input is monitored to suspend/restart the local transmitter (see [Figure 5](#)):

FIGURE 5. AUTO RTS AND CTS FLOW CONTROL OPERATION

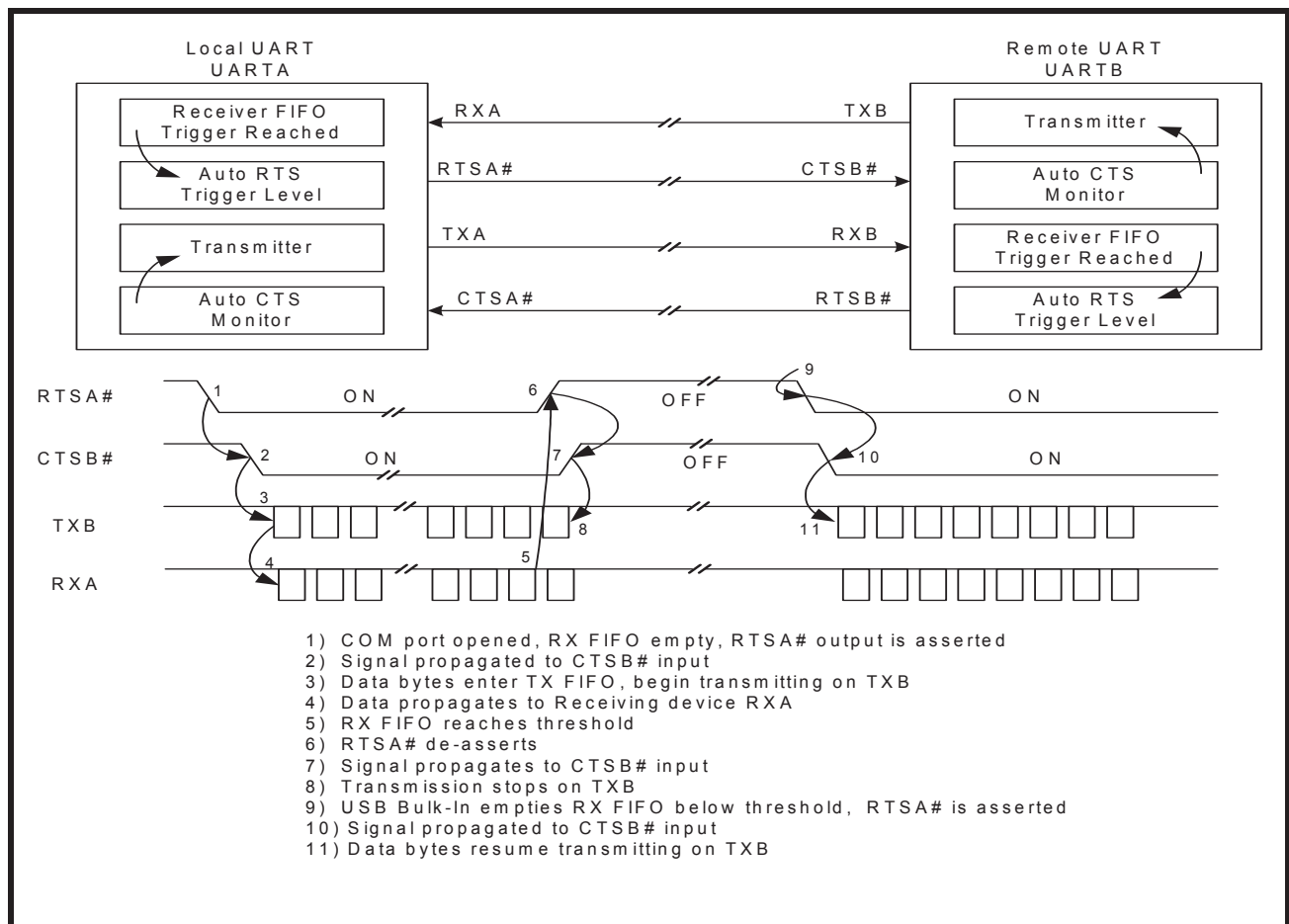

### 1.5.6 Automatic DTR/DSR Hardware Flow Control

Auto DTR/DSR hardware flow control behaves the same as the Auto RTS/CTS hardware flow control described above except that it uses the DTR# and DSR# signals. For Auto hardware flow control, FLOW\_CONTROL[2:0] = '001'. GPIO3 and GPIO2 become DTR# and DSR#, respectively, when GPIO\_MODE[2:0] = '010'.

## 4-CH FULL-SPEED USB UART

---

### 1.5.7 Automatic XON/XOFF Software Flow Control

When software flow control is enabled, the V1414 compares the receive data characters with the programmed Xon or Xoff characters. If the received character matches the programmed Xoff character, the V1414 will halt transmission as soon as the current character has completed transmission. Data transmission is resumed when a received character matches the Xon character. Software flow control is enabled when `FLOW_CONTROL[2:0] = '010'`.

### 1.5.8 Auto RS-485 Half-Duplex Control

The Auto RS-485 Half-Duplex Control feature changes the behavior of the GPIO5/RTS#/RS485 pin when enabled by the GPIO\_MODE register bits 2-0. See "Section 3.3.12, GPIO\_MODE Register Description (Read/Write)" on page 26. The FLOW\_CONTROL register must also be set appropriately for use in multidrop applications. See "Section 3.3.6, FLOW\_CONTROL Register Description (Read/Write)" on page 23. If enabled, the transmitter automatically asserts the GPIO5/RTS#/RS485 output prior to sending the data. By default, it de-asserts GPIO5/RTS#/RS485 following the last stop bit of the last character that has been transmitted, but the RS485\_DELAY register may be used to delay the deassertion. The polarity of the GPIO5/RTS#/RS485 signal may also be modified using the GPIO\_MODE register bit 3.

### 1.5.9 Multidrop Mode with address matching

The V1414 device has two address matching modes which are also set by the flow control register using modes 3 and 4. These modes are intended for a multi-drop network application. In these modes, the XON\_CHAR register holds a unicast address and the XOFF\_CHAR holds a multicast address. A unicast address is used by a transmitting master to broadcast an address to all attached slave devices that is intended for only one slave device. A multicast address is used to broadcast an address intended for more than one recipient device. Each attached slave device should have a unique unicast address value stored in the XON\_CHAR register, while multiple slaves may have the same multicast address stored in the XOFF\_CHAR register. An address match occurs when an address byte (9th bit or parity bit is '1') is received that matches the value stored in either the XON\_CHAR or XOFF\_CHAR register.

#### 1.5.9.1 Receiver

If an address match occurs in either flow control mode 3 or 4, the address byte will not be loaded into the RX FIFO, but all subsequent data bytes will be loaded into the RX FIFO. The UART Receiver will automatically be disabled when an address byte is received that does not match the values in the XON\_CHAR or XOFF\_CHAR register.

#### 1.5.9.2 Transmitter

In flow control mode 3, the UART transmitter is always enabled, irrespective of the Rx address match. In flow control mode 4, the UART transmitter will only be enabled if there is an Rx address match.

### 1.5.10 Programmable Turn-Around Delay

By default, the GPIO5/RTS#/RS485 pin will be de-asserted immediately after the stop bit of the last byte has been shifted when auto RS-485 half-duplex control is enabled by the GPIO\_MODE register. However, this may not be ideal for systems where the signal needs to propagate over long cables. Therefore, the de-assertion of GPIO5/RTS#/RS485 pin can be delayed from 1 to 15 bit times via the RS485\_DELAY register to allow for the data to reach distant UARTs.

### 1.5.11 Half-Duplex Mode

Half-duplex mode is enabled when `FLOW_CONTROL[3] = 1`. In this mode, the UART will ignore any data on the RX input when the UART is transmitting data.

### 1.5.12 USB Suspend

All USB peripheral devices must support the USB suspend mode. Per USB standard, the V1414 device will begin to enter the Suspend state if it does not detect any activity (including Start of Frame or SOF packets) on its USB data lines for 3 ms. The device must then reduce power consumption from VBUS power within the next 7 ms to the allowed limit of 2.5 mA for the suspended state. Note that in this context, the "device" is all circuitry (including the V1414) that draws power from the host VBUS.

---



### 1.5.13 Remote Wakeup

When the V1414 is suspended, the GPIO0/RI#/RWK# pin can be used to request that the host exit the Suspend state. A high to low transition on this pin will cause the device to signal a remote wakeup request to the host via a custom driver. Note that the standard CDC-ACM driver does not support this feature. In order for the remote wakeup to work, several things must be properly configured. First, the GPIO0/RI# pin must be configured as an input. Additionally, the V1414 device must have the remote wakeup feature support indicated in the USB attributes - See **“Section 1.3, I2C Interface” on page 10**. Lastly, the software driver must inform the USB host that the peripheral device supports the remote wake-up feature.

## 4-CH FULL-SPEED USB UART

## 2.0 USB CONTROL COMMANDS

The following table shows all of the USB Control Commands that are supported by the V1414. Commands included are standard USB commands, CDC-ACM commands and custom Exar commands. .

TABLE 4: SUPPORTED USB CONTROL COMMANDS

NAME	REQUEST TYPE	REQUEST	VALUE		INDEX		LENGTH		DESCRIPTION
DEV GET_STATUS	0x80	0	0	0	0	0	2	0	Device: remote wake-up + self-powered
IF GET_STATUS	0x81	0	0	0	1-4, 129-132	0	2	0	Interface: zero
EP GET_STATUS	0x82	0	0	0	0-4, 129-136	0	2	0	Endpoint: halted
DEV CLEAR_FEATURE	0x00	1	1	0	0	0	0	0	Device remote wake-up
EP CLEAR_FEATURE	0x02	1	0	0	0-4, 129-136	0	0	0	Endpoint halt
DEV SET_FEATURE	0x00	3	1	00	0	0	0	0	Device remote wake-up
DEV SET_FEATURE	0x00	3	2	0	0	test	0	0	Test mode
EP SET_FEATURE	0x02	3	0	0	0-4, 129-136	0	0	0	Endpoint halt
SET_ADDRESS	0x00	5	addr	0	0	0	0	0	
GET_DESCRIPTOR	0x80	6	0	1	0	0	len LSB	len MSB	Device descriptor
GET_DESCRIPTOR	0x80	6	0	2	0	0	len LSB	len MSB	Configuration descriptor
GET_CONFIGURATION	0x80	8	0	0	0	0	1	0	
SET_CONFIGURATION	0x00	9	n	0	0	0	0	0	
GET_INTERFACE	0x81	10	0	0	0-7	0	1	0	
CDC_ACM_IF SET_LINE_CODING	0x21	32	0	0	0, 2, 4, 6	0	7	0	Set the UART baud rate, parity, stop bits, etc.
CDC_ACM_IF GET_LINE_CODING	0xA1	33	0	0	0, 2, 4, 6	0	7	0	Get the UART baud rate, parity, stop bits, etc.
CDC_ACM_IF SET_CONTROL_LINE_STATE	0x21	34	val	0	0, 2, 4, 6	0	0	0	Set UART control lines



**TABLE 4: SUPPORTED USB CONTROL COMMANDS**

NAME	REQUEST TYPE	REQUEST	VALUE		INDEX		LENGTH		DESCRIPTION
			val LSB	val MSB	0, 2, 4, 6	0	0	0	
CDC_ACM_IF SEND_BREAK	0x21	35	val LSB	val MSB	0, 2, 4, 6	0	0	0	Send a break for the specified duration
XR_SET_REG	0x40	0	val	0	register	block	0	0	Exar custom command: set one 8-bit register val: 8-bit register value register address: see <a href="#">Table 7 on page 19</a> block number: see <a href="#">Table 5 on page 17</a>
XR_GETN_REG	0xC0	1	0	0	register	block	count LSB	count MSB	Exar custom register: get count 8-bit registers register address: see <a href="#">Table 7 on page 19</a> block number: see <a href="#">Table 5 on page 17</a>

### 2.1 UART Block Numbers

The table below lists the block numbers for accessing each of the UART channels and the UART Manager..

**TABLE 5: CONTROL BLOCKS**

BLOCK NAME	BLOCK NUMBER	DESCRIPTION
UART Channel A	0	The configuration and control registers for UART channel A.
UART Channel B	1	The configuration and control registers for UART channel B.
UART Channel C	2	The configuration and control registers for UART channel C.
UART Channel D	3	The configuration and control registers for UART channel D.
UART Manager	4	The control registers for the UART Manager. The UART Manager enables/disables the TX and RX FIFOs for each UART.
I2C EEPROM	0x65	Accesses external EEPROM via I2C interface.
UART Custom	0x66	Custom UART control registers. Enables / disables for wide mode, low latency mode and custom interrupt packet.

## 4-CH FULL-SPEED USB UART

## 3.0 REGISTER SET DESCRIPTION

The internal register set of the V1414 consists of 3 different blocks of registers: the UART Manager, UART registers and UART miscellaneous registers. The UART Manager controls the TX and RX enables and FIFOs of all UART channels. The UART registers configure and control the remaining UART channel functionality with the exception of low latency mode, wide mode and custom interrupt packet enables in the UART custom register block.

Registers are accessed only via the USB interface by the XR\_SET\_REG and XR\_GET\_REG commands listed in [Table 4](#). The register address offsets are given in [Table 6](#), [Table 7](#) and [Table 15](#), and the register blocks are given in [Table 5](#).

## 3.1 UART Manager Registers..

TABLE 6: UART MANAGER REGISTERS

ADDRESS	REGISTER NAME	BIT-7	BIT-6	BIT-5	BIT-4	BIT-3	BIT-2	BIT-1	BIT-0
0X10	FIFO_ENABLE_CHA	0	0	0	0	0	0	RX	TX
0X11	FIFO_ENABLE_CHB	0	0	0	0	0	0	RX	TX
0X12	FIFO_ENABLE_CHC	0	0	0	0	0	0	RX	TX
0x13	FIFO_ENABLE_CHD	0	0	0	0	0	0	RX	TX
0X18	RX_FIFO_RESET_CHA	Bit-7	Bit-6	Bit-5	Bit-4	Bit-3	Bit-2	Bit-1	Bit-0
0X19	RX_FIFO_RESET_CHB	Bit-7	Bit-6	Bit-5	Bit-4	Bit-3	Bit-2	Bit-1	Bit-0
0x1A	RX_FIFO_RESET_CHC	Bit-7	Bit-6	Bit-5	Bit-4	Bit-3	Bit-2	Bit-1	Bit-0
0x1B	RX_FIFO_RESET_CHD	Bit-7	Bit-6	Bit-5	Bit-4	Bit-3	Bit-2	Bit-1	Bit-0
0x1C	TX_FIFO_RESET_CHA	Bit-7	Bit-6	Bit-5	Bit-4	Bit-3	Bit-2	Bit-1	Bit-0
0x1D	TX_FIFO_RESET_CHB	Bit-7	Bit-6	Bit-5	Bit-4	Bit-3	Bit-2	Bit-1	Bit-0
0x1E	TX_FIFO_RESET_CHC	Bit-7	Bit-6	Bit-5	Bit-4	Bit-3	Bit-2	Bit-1	Bit-0
0x1F	TX_FIFO_RESET_CHD	Bit-7	Bit-6	Bit-5	Bit-4	Bit-3	Bit-2	Bit-1	Bit-0

## 3.1.1 FIFO\_ENABLE Registers

Enables the RX FIFO and TX FIFOs. For proper functionality, the UART TX and RX must be enabled in the following order:

```
FIFO_ENABLE_CHx = 0x1    // Enable TX FIFO
UART_ENABLE = 0x3        // Enable TX and RX of that channel
FIFO_ENABLE_CHx = 0x3    // Enable RX FIFO
```

## 3.1.2 RX\_FIFO\_RESET and TX\_FIFO\_RESET Registers

Writing a non-zero value to these registers resets the FIFOs.



3.2 UART Register Map

TABLE 7: UART REGISTERS

ADDRESS	REGISTER NAME	BIT-7	BIT-6	BIT-5	BIT-4	BIT-3	BIT-2	BIT-1	BIT-0
0X00	Reserved	0	0	0	0	0	0	0	0
0X01	Reserved	0	0	0	0	0	0	0	0
0X02	Reserved	0	0	0	0	0	0	0	0
0X03	UART_ENABLE	0	0	0	0	0	0	RX	TX
0X04	CLOCK_DIVISOR0	Bit-7	Bit-6	Bit-5	Bit-4	Bit-3	Bit-2	Bit-1	Bit-0
0x05	CLOCK_DIVISOR1	Bit-15	Bit-14	Bit-13	Bit-12	Bit-11	Bit-10	Bit-9	Bit-8
0x06	CLOCK_DIVISOR2	0	0	0	0	0	Bit-18	Bit-17	Bit-16
0x07	TX_CLOCK_MASK0	Bit-7	Bit-6	Bit-5	Bit-4	Bit-3	Bit-2	Bit-1	Bit-0
0x08	TX_CLOCK_MASK1	Bit-15	Bit-14	Bit-13	Bit-12	Bit-11	Bit-10	Bit-9	Bit-8
0x09	RX_CLOCK_MASK0	Bit-7	Bit-6	Bit-5	Bit-4	Bit-3	Bit-2	Bit-1	Bit-0
0x0A	RX_CLOCK_MASK1	Bit-15	Bit-14	Bit-13	Bit-12	Bit-11	Bit-10	Bit-9	Bit-8
0x0B	CHARACTER_FORMAT	Stop	Parity			Data Bits			
0x0C	FLOW_CONTROL	0	0	0	0	Half-Duplex	Flow Control Mode Select		
0x0D	Reserved	0	0	0	0	0	0	0	0
0x0E	Reserved	0	0	0	0	0	0	0	0
0x0F	Reserved	0	0	0	0	0	0	0	0
0x10	XON_CHAR	Bit-7	Bit-6	Bit-5	Bit-4	Bit-3	Bit-2	Bit-1	Bit-0
0x11	XOFF_CHAR	Bit-7	Bit-6	Bit-5	Bit-4	Bit-3	Bit-2	Bit-1	Bit-0
0x12	LOOPBACK_CTL	0	0	0	0	0	En	Chan	
0x13	ERROR_STATUS	Break Status	Overrun Error	Parity Error	Framing Error	Break Error	0	0	0
0x14	TX_BREAK	Bit-7	Bit-6	Bit-5	Bit-4	Bit-3	Bit-2	Bit-1	Bit-0
0x15	RS485_DELAY	0	0	0	0	Delay			
0x16	Reserved	0	0	0	0	0	0	0	0
0x17	Reserved	0	0	0	0	0	0	0	0
0x18	Reserved	0	0	0	0	0	0	0	0
0x19	Reserved	0	0	0	0	0	0	0	0
0x1A	GPIO_MODE	0	0	0	0	RS485 Polarity	Mode Select		
0x1B	GPIO_DIRECTION	0	0	GPIO5	GPIO4	GPIO3	GPIO2	GPIO1	GPIO0
0x1C	GPIO_INT_MASK	0	0	GPIO5	GPIO4	GPIO3	GPIO2	GPIO1	GPIO0
0x1D	GPIO_SET	0	0	GPIO5	GPIO4	GPIO3	GPIO2	GPIO1	GPIO0
0x1E	GPIO_CLEAR	0	0	GPIO5	GPIO4	GPIO3	GPIO2	GPIO1	GPIO0
0x1F	GPIO_STATUS	0	0	GPIO5	GPIO4	GPIO3	GPIO2	GPIO1	GPIO0

### 3.3 UART Register Descriptions

All register bits default to a value of '0' unless otherwise noted.

#### 3.3.1 UART\_ENABLE Register Description (Read/Write)

This register enables the UART TX and RX. For proper functionality, the UART TX and RX must be enabled in the following order:

```
FIFO_ENABLE_CHx = 0x1    // Enable TX FIFO
UART_ENABLE = 0x3        // Enable TX and RX of that channel
FIFO_ENABLE_CHx = 0x3    // Enable RX FIFO
```

#### UART\_ENABLE[0]: Enable UART TX

- Logic 0 = UART TX disabled.
- Logic 1 = UART TX enabled.

#### UART\_ENABLE[1]: Enable UART RX

- Logic 0 = UART RX disabled.
- Logic 1 = UART RX enabled.

#### UART\_ENABLE[7:2]: Reserved

These bits are reserved and should remain '0'.

#### 3.3.2 CLOCK\_DIVISOR0, CLOCK\_DIVISOR1, CLOCK\_DIVISOR2 Register Description (Read/Write)

These registers are used for programming the baud rate. The V1414 uses a 19-bit divisor and 16-bit mask register. Using the internal 48MHz oscillator, the 19-bit divisor is calculated as follows:

$$\text{CLOCK\_DIVISOR} = \text{Trunc} ( 48000000 / \text{Baud Rate} )$$

For example, if the the baud rate is 115200bps, then

$$\text{CLOCK\_DIVISOR} = \text{Trunc} ( 48000000 / 115200 ) = \text{Trunc} ( 416.66667 ) = 416$$

#### CLOCK\_DIVISOR0[7:0]: Baud rate clock divisor bits [7:0]

#### CLOCK\_DIVISOR1[7:0]: Baud rate clock divisor bits [15:8]

#### CLOCK\_DIVISOR2[2:0]: Baud rate clock divisor bits [18:16]

#### CLOCK\_DIVISOR2[7:3]: Reserved

These bits are reserved and should remain '0'.

#### 3.3.3 TX\_CLOCK\_MASK0, TX\_CLOCK\_MASK1 Register Description (Read/Write)

A look-up table is used for the value of the 16-bit TX Clock mask registers. The index of the look-up table is calculated as follows:

$$\text{index} = \text{Trunc} ( ( ( 48000000 / \text{Baud Rate} ) - \text{CLOCK\_DIVISOR} ) * 32 )$$

For example, if the baud rate is 115200bps, then the index will be:

$$\text{index} = \text{Trunc} ( ( ( 48000000 / 115200 ) - 416 ) * 32 ) = \text{Trunc} ( 21.3333 ) = 21$$

The values for some baud rates to program the TX\_CLOCK\_MASK registers are listed in [Table 8](#). For baud rates that are not listed, use the index to select TX\_CLOCK\_MASK register values from [Table 9](#).

#### 3.3.4 RX\_CLOCK\_MASK0, RX\_CLOCK\_MASK1 Register Description (Read/Write)

The values for some baud rates to program the RX\_CLOCK\_MASK registers are listed in [Table 8](#). For baud rates that are not listed, use the same index calculated for the TX\_CLOCK\_MASK register to select RX\_CLOCK\_MASK register values from [Table 9](#).



TABLE 8: CLOCK DIVISOR AND CLOCK MASK VALUES FOR COMMON BAUD RATES

BAUD RATE (BPS)	CLOCK DIVISOR (DECIMAL)	TX CLOCK MASK (HEX)	RX CLOCK MASK (HEX)
1200	40000	0x0000	0x0000
2400	20000	0x0000	0x0000
4800	10000	0x0000	0x0000
9600	5000	0x0000	0x0000
19200	2500	0x0000	0x0000
38400	1250	0x0000	0x0000
57600	833	0x0912	0x0924
115200	416	0x0B6D	0x0B6A
230400	208	0x0912	0x0924
460800	104	0x0208	0x0040
500000	96	0x0000	0x0000
576000	83	0x0912	0x0924
921600	52	0x0040	0x0000
1000000	48	0x0000	0x0000
1152000	41	0x0B6D	0x0DB6
1500000	32	0x0000	0x0000
2000000	24	0x0000	0x0000
2500000	19	0x0104	0x0108
3000000	16	0x0000	0x0000
3125000	15	0x0492	0x0492
3500000	13	0x076D	0x0BB6
4000000	12	0x0000	0x0000
4250000	11	0x0122	0x0224
6250000	7	0x0B6D	0x0DB6
8000000	6	0x0000	0x0000
12000000	4	0x0000	0x0000

For baud rates that are not listed in the table above, use the index value calculated using the formula in “Section 3.3.3, TX\_CLOCK\_MASK0, TX\_CLOCK\_MASK1 Register Description (Read/Write)” on page 20 to determine which TX Clock and RX Clock Mask register values to use from Table 9. For the the RX Clock Mask register, there are 2 values listed and would depend on whether the Clock Divisor is even or odd. For even Clock Divisors, use the value from the first column. For odd Clock Divisors, use the value from the last column.

TABLE 9: TX AND RX CLOCK MASK VALUES

INDEX (DECIMAL)	TX CLOCK MASK (HEX)	RX CLOCK MASK (HEX) - EVEN CLOCK DIVISOR	RX CLOCK MASK (HEX) - ODD CLOCK DIVISOR
0	0x0000	0x0000	0x0000
1	0x0000	0x0000	0x0000
2	0x0100	0x0000	0x0100
3	0x0020	0x0400	0x0020
4	0x0010	0x0100	0x0010
5	0x0208	0x0040	0x0208
6	0x0104	0x0820	0x0108
7	0x0844	0x0210	0x0884
8	0x0444	0x0110	0x0444
9	0x0122	0x0888	0x0224
10	0x0912	0x0448	0x0924
11	0x0492	0x0248	0x0492
12	0x0252	0x0928	0x0292
13	0x094A	0x04A4	0x0A52
14	0x052A	0x0AA4	0x054A
15	0x0AAA	0x0954	0x04AA
16	0x0AAA	0x0554	0x0AAA
17	0x0555	0x0AD4	0x05AA
18	0x0B55	0x0AB4	0x055A
19	0x06B5	0x05AC	0x0B56
20	0x05B5	0x0D6C	0x06D6
21	0x0B6D	0x0B6A	0x0DB6
22	0x076D	0x06DA	0x0BB6
23	0x0EDD	0x0DDA	0x076E
24	0x0DDD	0x0BBA	0x0EEE
25	0x07BB	0x0F7A	0x0DDE
26	0x0F7B	0x0EF6	0x07DE
27	0x0DF7	0x0BF6	0x0F7E
28	0x07F7	0x0FEE	0x0EFE
29	0x0FDF	0x0FBE	0x07FE
30	0x0F7F	0x0EFE	0x0FFE
31	0x0FFF	0x0FFE	0x0FFD

### 3.3.5 CHARACTER\_FORMAT Register Description (Read/Write)

This register controls the character format such as the word length (7, 8 or 9), parity (odd, even, forced '0', or forced '1') and number of stop bits (1 or 2).

**CHARACTER\_FORMAT[3:0]: Data Bits.**

**TABLE 10: DATA BITS**

DATA BITS	CHARACTER_FORMAT[3:0]
7	0111
8	1000
9	1001

All other values for CHARACTER\_FORMAT[3:0] are reserved.

**CHARACTER\_FORMAT[6:4]: Parity Mode Select**

These bits select the parity mode. If 9-bit data mode has been selected, then writing to these bits will not have any effect. In other words, there will not be an additional parity bit.

**TABLE 11: PARITY SELECTION**

BIT-6	BIT-5	BIT-4	PARITY SELECTION
0	0	0	No parity
0	0	1	Odd parity
0	1	0	Even parity
0	1	1	Force parity to mark, "1"
1	0	0	Force parity to space, "0"

**CHARACTER\_FORMAT[7]: Stop Bit select**

This register selects the number of stop bits to add to the transmitted character and how many stop bits to check for in the received character.

**TABLE 12: STOP BIT SELECTION**

BIT-7	NUMBER OF STOP BITS
0	1 stop bit
2	2 stop bits

### 3.3.6 FLOW\_CONTROL Register Description (Read/Write)

These registers select the flow control mode. These registers should only be written to when the UART is disabled. Writing to the FLOW\_CONTROL register when the UART is enabled will result in undefined behavior. Note that the FLOW\_CONTROL register settings are used in conjunction with the GPIO\_MODE register.

**FLOW\_CONTROL[2:0]: Flow control mode select****TABLE 13: FLOW CONTROL MODE SELECTION**

MODE	BIT-2	BIT-1	BIT-0	MODE DESCRIPTION
0	0	0	0	No flow control, no address matching.
1	0	0	1	HW flow control enabled. Auto RTS/CTS or DTR/DSR must be selected by GPIO_MODE.
2	0	1	0	SW flow control enabled
3	0	1	1	Multidrop mode - RX only after address match, TX independent. (Typically used with GPIO_MODE 3)
4	1	0	0	Multidrop mode - RX / TX only after address match. (Typically used with GPIO_MODE 4)

**FLOW\_CONTROL[3]: Half-Duplex Mode**

- Logic 0 = Normal (full-duplex) mode. The UART can transmit and receive data at the same time.
- Logic 1 = Half-duplex Mode. In half-duplex mode, any data on the RX pin is ignored when the UART is transmitting data.

**FLOW\_CONTROL[7:4]: Reserved**

These bits are reserved and should remain '0'.

**3.3.7 XON\_CHAR, XOFF\_CHAR Register Descriptions (Read/Write)**

The XON\_CHAR and XOFF\_CHAR registers store the XON and XOFF characters, respectively, that are used in the Automatic Software Flow control.

**XON\_CHAR[7:0]: XON Character**

In Automatic Software Flow control mode, the UART will resume data transmission when the XON character has been received.

For behavior in the Address Match mode, see [“Section 1.5.9, Multidrop Mode with address matching” on page 14.](#)

For behavior in the Address Match with TX Flow Control mode, see [“Section 1.5.9, Multidrop Mode with address matching” on page 14.](#)

**XOFF\_CHAR[7:0]: XOFF Character**

In Automatic Software Flow control mode, the UART will suspend data transmission when the XOFF character has been received.

For behavior in the Address Match mode, see [“Section 1.5.9, Multidrop Mode with address matching” on page 14.](#)

For behavior in the Address Match with TX Flow Control mode, see [“Section 1.5.10, Programmable Turn-Around Delay” on page 14.](#)



### 3.3.8 LOOPBACK\_CTL Register Descriptions (Read/Write)

#### LOOPBACK\_CTL[1:0]: Channel

- Value 0 = UART Channel A
- Value 1 = UART Channel B
- Value 2 = UART Channel C
- Value 3 = UART Channel D

#### LOOPBACK\_CTL[2]: Enable

- Logic 0 = Internal UART (TX to RX) loopback is disabled.
- Logic 1 = Internal UART (TX to RX) loopback is enabled.

#### LOOPBACK\_CTL[7:3]: Reserved

These bits are reserved and should remain '0'.

### 3.3.9 ERROR\_STATUS Register Description - Read-only

This register reports any errors that may have occurred on the line such as framing, parity and overrun as well as break status.

#### ERROR\_STATUS[2:0]: Reserved

These bits are reserved. Any values read from these bits should be ignored.

#### ERROR\_STATUS[3]: Break status

- Logic 0 = No break condition
- Logic 1 = A break condition has been detected (clears after read).

#### ERROR\_STATUS[4]: Framing Error

- Logic 0 = No framing error
- Logic 1 = A framing error has been detected (clears after read). A framing error occurs when a stop bit is not present when it is expected.

#### ERROR\_STATUS[5]: Parity Error

- Logic 0 = No parity error
- Logic 1 = A parity error has been detected (clears after read).

#### ERROR\_STATUS[6]: Overrun Error

- Logic 0 = No overrun error
- Logic 1 = An overrun error has been detected (clears after read). An overrun error occurs when the RX FIFO is full and another byte of data is received.

#### ERROR\_STATUS[7]: Break Status

- Logic 0 = Break condition is no longer present.
- Logic 1 = Break condition is currently being detected.

### 3.3.10 TX\_BREAK Register Description (Read/Write)

Writing a non-zero value to this register causes a break condition to be generated continuously until the register is cleared. If data is being shifted out of the TX pin, the data will be completely shifted out before the break condition is generated.

### 3.3.11 RS485\_DELAY Register Description (Read/Write)

#### RS485\_DELAY[3:0]: Turn-around delay

This is the number of bit times the V1414 waits before de-asserting the GPIO5/RTS#/RS485 pin when it is configured for automatic RS-485 half-duplex control.

#### RS485\_DELAY[7:4]: Reserved

These bits are reserved and should be '0'.

### 3.3.12 GPIO\_MODE Register Description (Read/Write)

#### GPIO\_MODE[2:0]: GPIO Mode Select

There are 4 modes of operation for the GPIOs. The descriptions can be found in [“Section 1.5, UART” on page 11](#).

TABLE 14: GPIO MODES

BITS [2:0]	GPIO0	GPIO1	GPIO2	GPIO3	GPIO4	GPIO5	MODE DESCRIPTION
000	GPIO0	GPIO1	GPIO2	GPIO3	GPIO4	GPIO5	GPIO Mode, All GPIO pins available as GPIO
001	GPIO0	GPIO1	GPIO2	GPIO3	CTS#	RTS#	GPIO4 and GPIO5 used for Auto RTS/CTS HW Flow Control
010	GPIO0	GPIO1	DSR#	DTR#	GPIO4	GPIO5	GPIO2 and GPIO3 used for Auto DTR/DSR HW Flow Control
011	GPIO0	GPIO1	GPIO2	GPIO3	GPIO4	RS485	GPIO5 used for auto RS-485 half-duplex control
100	GPIO0	GPIO1	GPIO2	GPIO3	GPIO4	RS485	GPIO5 used for auto RS-485 half-duplex control after address match (See FLOW_CONTROL mode 4).

#### GPIO\_MODE[3]: RS485 Polarity

- Logic 0 = GPIO5/RTS#/RS485 Low for TX
- Logic 1 = GPIO5/RTS#/RS485 High for TX

#### GPIO\_MODE[7:4]: Reserved

These register bits are reserved. When writing to these bits, the value should be '0'. When reading from these bits, they are undefined and should be ignored.

### 3.3.13 GPIO\_DIRECTION Register Description (Read/Write)

This register controls the direction of pins configured as GPIO. (Pins configured for UART functions via the GPIO\_MODE register, e.g. RTS# are not controlled or reported in the GPIO\_DIRECTION register.)

#### GPIO\_DIRECTION[5:0]: GPIOx Direction

- Logic 0 = GPIOx is an input.
- Logic 1 = GPIOx is an output.

#### GPIO\_DIRECTION[7:6]: Reserved

These register bits are reserved and should be '0'.

### 3.3.14 GPIO\_INT\_MASK Register Description (Read/Write)

Enables / disables generation of a USB interrupt packet at the change of state of GPIO pins when they are configured as inputs.

**GPIO\_INT\_MASK[5:0]: GPIOx Interrupt Mask**

- Logic 0 = A change on this input causes the device to generate an interrupt packet.
- Logic 1 = A change on this input does not cause the device to generate an interrupt packet.

**GPIO\_INT\_MASK[7:6]: Reserved**

These register bits are reserved and should be '0'.

**3.3.15 GPIO\_SET Register Description (Read/Write)**

Writing a '1' in this register drives the GPIO output high. Writing a '0' to a bit has no effect. Bits 7-6 are unused and should be '0'.

**3.3.16 GPIO\_CLEAR Register Description (Read/Write)**

Writing a '1' in this register drives the GPIO output low. Writing a '0' to a bit has no effect. Bits 7-6 are unused and should be '0'.

**3.3.17 GPIO\_STATUS Register Description (Read-Only)**

This register reports the current state of the GPIO pin.

**3.4 UART Custom Registers**

**TABLE 15: UART CUSTOM REGISTERS**

ADDRESS	REGISTER NAME	BIT-7	BIT-6	BIT-5	BIT-4	BIT-3	BIT-2	BIT-1	BIT-0
0X03	UART CHAN A CUSTOM	0	0	0	0	0	0	MaxPkt-Size	WIDE_EN
0X04	UART CHAN A LOW_LATENCY	0	0	0	0	0	0	0	EN
0X06	UART CHAN A CUSTOM_INT_PACKET	0	GPIO5	GPIO4	GPIO3	GPIO0	0	GPIO2	GPIO1
0X0B	UART CHAN B CUSTOM	0	0	0	0	0	0	MaxPktSize	WIDE_EN
0X0C	UART CHAN B LOW_LATENCY	0	0	0	0	0	0	0	EN
0X0E	UART CHAN B CUSTOM_INT_PACKET	0	GPIO5	GPIO4	GPIO3	GPIO0	0	GPIO2	GPIO1
0X13	UART CHAN C CUSTOM	0	0	0	0	0	0	MaxPktSize	WIDE_EN
0X14	UART CHAN C LOW_LATENCY	0	0	0	0	0	0	0	EN
0X16	UART CHAN C CUSTOM_INT_PACKET	0	GPIO5	GPIO4	GPIO3	GPIO0	0	GPIO2	GPIO1
0X1B	UART CHAN D CUSTOM	0	0	0	0	0	0	MaxPktSize	WIDE_EN
0X1C	UART CHAN D LOW_LATENCY	0	0	0	0	0	0	0	EN
0X1E	UART CHAN D CUSTOM_INT_PACKET	0	GPIO5	GPIO4	GPIO3	GPIO0	0	GPIO2	GPIO1

## 4-CH FULL-SPEED USB UART

### 3.4.1 CUSTOM Register Description (Read/Write)

This register enables the Wide mode functionality for the UART.

#### CUSTOM[0]: Enable wide mode

- Logic 0 = Normal (7, 8 or 9 bit data) mode
- Logic 1 = Wide mode - See “[Section 1.5.1.1, Wide Mode Transmit](#)” on page 11, “[Section 1.5.2.3, Wide mode receive operation with 7 or 8-bit data](#)” on page 12 and “[Section 1.5.2.4, Wide mode receive operation with 9-bit data](#)” on page 12.

#### CUSTOM[1]: Max Packet Size

- Logic 0 = bMaxPacketSize = 64 bytes

Logic 1 = bMaxPacketSize = 63 bytes (this bit is automatically set to '1' if the XR21V1414 receives a CDC\_ACM USB command)

#### CUSTOM[7:2]: Reserved

These bits are reserved and should remain '0'.

### 3.4.2 LOW\_LATENCY Register Description (Read/Write)

This register is automatically set to logic '1' for baud rates below 46921 bps, and can be manually set for baud rates of 46921 bps and higher. This register enables the Low latency feature of the UART. Write to this register following any desired baud rate setting change.

#### LOW\_LATENCY[0]: Enable Low Latency mode

- Logic 0 = Receive data is not forwarded from the Rx FIFO until bMaxPacketSize (64 bytes) or timeout (3 characters) has occurred.
- Logic 1 = All data in the RX FIFO is provided to the USB host at the next BULK IN request irrespective of the number of bytes in the FIFO.

#### LOW\_LATENCY[7:1]: Reserved

These bits are reserved and should remain '0'.

### 3.4.3 CUSTOM\_INT\_PACKET (Read/Write)

This register is used to enable / disable GPIO status in the high data byte of the custom interrupt packet. See [Table 16, “Interrupt Packet Format,”](#) on page 29 and [Table 18, “Data Field of Customized Interrupt Packet - Exar Vendor Specific,”](#) on page 30.

#### CUSTOM\_INT\_PACKET[0]: GPIO1

- Logic 0 = Disable GPIO1 status in custom interrupt packet.
- Logic 1 = Enable GPIO1 status in custom interrupt packet.

**CUSTOM\_INT\_PACKET[1]: GPIO2**

- Logic 0 = Disable GPIO2 status in custom interrupt packet.
- Logic 1 = Enable GPIO2 status in custom interrupt packet.

**CUSTOM\_INT\_PACKET[2]: Reserved**

- This bit is reserved and should remain '0'.

**CUSTOM\_INT\_PACKET[3]: GPIO0**

- Logic 0 = Disable GPIO0 status in custom interrupt packet.
- Logic 1 = Enable GPIO0 status in custom interrupt packet.

**CUSTOM\_INT\_PACKET[4]: GPIO3**

- Logic 0 = Disable GPIO3 status in custom interrupt packet.
- Logic 1 = Enable GPIO3 status in custom interrupt packet.

**CUSTOM\_INT\_PACKET[5]: GPIO4**

- Logic 0 = Disable GPIO4 status in custom interrupt packet.
- Logic 1 = Enable GPIO4 status in custom interrupt packet.

**CUSTOM\_INT\_PACKET[6]: GPIO5**

- Logic 0 = Disable GPIO5 status in custom interrupt packet.
- Logic 1 = Enable GPIO5 status in custom interrupt packet.

**CUSTOM\_INT\_PACKET[7]: Reserved**

This bit is reserved and should remain '0'.

**TABLE 16: INTERRUPT PACKET FORMAT**

OFFSET	FIELD	SIZE (BYTES)	VALUE	DESCRIPTION
0	bmRequestType	1	8'b10100001	D7 = Device-to-host direction D6:5 = Class Type D4-0: = Interface Recipient
1	bNotification	1	8'h20	Defined encoding for SERIAL_STATE
2	wValue	2	16'h0000	
4	wIndex	2	16'h0000	D15-8 = Reserved (0) D7-0 = Interface number, 8'h00 for the CDC Command Interface
6	wLength	2	16'h0002	2 bytes of transferred data
8	Data	2	Standard int_status (See <a href="#">Table 17</a> or <a href="#">Table 18</a> )	D15-7 = Reserved (0) D6 = bOverRun D5 = bParity D4 = bFraming D3 = bRingSignal (RI) D2 = bBreak D1 = bTxCarrier (DSR) D0 = bRxCarrier (CD)

TABLE 17: DATA FIELD OF STANDARD INTERRUPT PACKET

BIT(s)	FIELD	DESCRIPTION
D15..D7		Reserved (0)
D6	bOverRun	Received data has been discarded due to overrun in the device.
D5	bParity	A parity error has occurred.
D4	bFraming	A framing error has occurred.
D3	bRingSignal	State of ring signal detection of the device.
D2	bBreak	State of break detection mechanism of the device.
D1	bTxCarrier	State of transmission carrier. This signal corresponds to V.24 signal 106 and RS-232 signal DSR.
D0	bRxCarrier	State of receiver carrier detection mechanism of device. This signal corresponds to V.24 signal 109 and RS-232 signal DCD.

If the Exar vendor specific packet mapping is enabled then the data field also includes status for all of the UART / GPIO pins as follows:

TABLE 18: DATA FIELD OF CUSTOMIZED INTERRUPT PACKET - EXAR VENDOR SPECIFIC

BIT(s)	FIELD	DESCRIPTION
15	D15	Reserved (0)
14	D14	bGPIO5 (RTS)
13	D13	bGPIO4 (CTS)
12	D12	bGPIO3 (DTR)
11	D11	bGPIO0 (RI)
10	D10	Reserved (0)
9	D9	bGPIO2 (DSR)
8	D8	bGPIO1 (CD)
7	D7	Reserved (0)
6	D6	bOverRun
5	D5	bParity
4	D4	bFraming
3	D3	bRingSignal (RI)
2	D2	bBreak
1	D1	bTxCarrier (DSR)
0	D0	bRxCarrier (CD)

4.0 ELECTRICAL CHARACTERISTICS

TABLE 19: ABSOLUTE MAXIMUM RATINGS

PARAMETER	RATING	UNIT
Vcc Supply Voltage	+ 4.0	V
Input Voltage (all pins except USBD+ and USBD-)	- 0.3 to + 6.0	V
Input Voltage (USBD+ and USBD-)	- 0.3 to + 5.75	V
Junction Temperature	125	deg. C

DC ELECTRICAL CHARACTERISTICS - POWER CONSUMPTION

UNLESS OTHERWISE NOTED: TA = -40° TO +85°C, VCC IS 2.97 TO 3.63V

SYMBOL	PARAMETER	LIMITS 3.3V			UNITS	CONDITIONS
		MIN	TYP	MAX		
I <sub>CC</sub>	Power Supply Current		16	20	mA	
I <sub>Susp</sub>	Suspend mode Current		1.5	1.65	mA	

DC ELECTRICAL CHARACTERISTICS - UART, LOWPOWER & GPIO PINS

UNLESS OTHERWISE NOTED: TA = -40° TO +85°C, VCC IS 2.97 TO 3.63V

SYMBOL	PARAMETER	LIMITS 3.3V		UNITS	CONDITIONS
		MIN	MAX		
V <sub>IL</sub>	Input Low Voltage	-0.3	0.8	V	
V <sub>IH</sub>	Input High Voltage	2.0	5.5	V	
V <sub>OL</sub>	Output Low Voltage		0.3	V	I <sub>OL</sub> = 4 mA
V <sub>OH</sub>	Output High Voltage	2.2		V	I <sub>OH</sub> = -4 mA
I <sub>IL</sub>	Input Low Leakage Current		±10	uA	
I <sub>IH</sub>	Input High Leakage Current		±10	uA	
C <sub>IN</sub>	Input Pin Capacitance		5	pF	

**DC ELECTRICAL CHARACTERISTICS - USB I/O PINS**

UNLESS OTHERWISE NOTED: TA = -40° TO +85°C, VCC IS 2.97 TO 3.63V

SYMBOL	PARAMETER	LIMITS 3.3V		UNITS	CONDITIONS
		MIN	MAX		
V <sub>IL</sub>	Input Low Voltage	-0.3	0.8	V	
V <sub>IH</sub>	Input High Voltage	2.0	5.5	V	
V <sub>OL</sub>	Output Low Voltage	0	0.3	V	External 15 K Ohm to GND on USB <sub>D-</sub> pin
V <sub>OH</sub>	Output High Voltage	2.8	3.6	V	External 15 K Ohm to GND on USB <sub>D-</sub> pin
V <sub>DivZ</sub>	Driver Output Impedance	28	44	Ohms	
I <sub>OSC</sub>	Open short current Current		38.5	mA	1.5 V on USB <sub>D+</sub> and USB <sub>D-</sub>



PACKAGE DIMENSIONS (48 PIN TQFP - 7 X 7 X 1 mm)

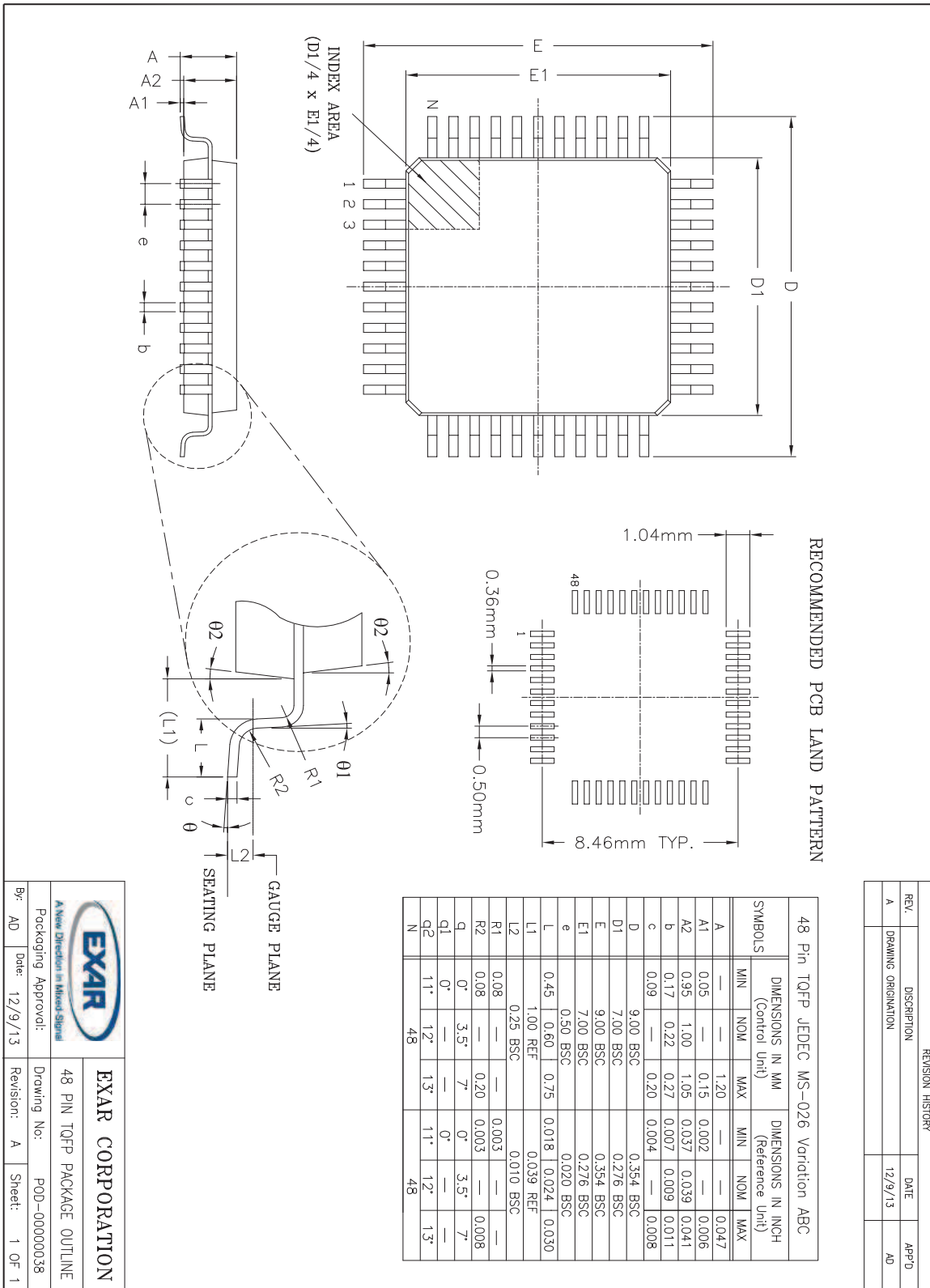

		<b>EXAR CORPORATION</b>	
A New Direction in Mixed-Signal Packaging Approval:		48 PIN TQFP PACKAGE OUTLINE Drawing No:	
By: AD Date: 12/9/13		Revision: A Sheet: 1 OF 1	
P.O.D.—00000038		P.O.D.—00000038	

REVISION HISTORY		DATE	APP'D
REV.	DISCUSSION		
A	DRAWING ORIGINATION	12/9/13	AD

NOTE: TQFP48 theta ja = 64.1 deg. C/W, theta jc = 6.5 deg. C / W. All values are typical.

## 4-CH FULL-SPEED USB UART

**REVISION HISTORY**

DATE	REVISION	DESCRIPTION
June 2009	1.0.0	Released Datasheet.
September 2010	1.1.0	Clarified pin functionality, wide mode and low latency mode including registers / blocks, clarified FLOW_CONTROL and GPIO_MODE register functionality.
April 2012	1.2.0	Updated ordering information, SDA/SCL pin types, modified GPIO0 pin name and added LOOPBACK_CTL register and description. Updated LOWPOWER pin description, bMaxPacketSize and DC electrical characteristics. See PCN12-0305-01 for more details.
December 2013	1.3.0	Added Windows driver versions, added absolute maximum tables, added ESD protection ratings, added QFN package center pad to pin descriptions, minor clarifications including requirement for even Product ID in Windows OS. [ECN:1402-06]

**NOTICE**

EXAR Corporation reserves the right to make changes to the products contained in this publication in order to improve design, performance or reliability. EXAR Corporation assumes no responsibility for the use of any circuits described herein, conveys no license under any patent or other right, and makes no representation that the circuits are free of patent infringement. Charts and schedules contained here in are only for illustration purposes and may vary depending upon a user's specific application. While the information in this publication has been carefully checked; no responsibility, however, is assumed for inaccuracies.

EXAR Corporation does not recommend the use of any of its products in life support applications where the failure or malfunction of the product can reasonably be expected to cause failure of the life support system or to significantly affect its safety or effectiveness. Products are not authorized for use in such applications unless EXAR Corporation receives, in writing, assurances to its satisfaction that: (a) the risk of injury or damage has been minimized; (b) the user assumes all such risks; (c) potential liability of EXAR Corporation is adequately protected under the circumstances.

Copyright 2013 EXAR Corporation

Datasheet December 2013.

Send your UART technical inquiry with technical details to hotline: [uarttechsupport@exar.com](mailto:uarttechsupport@exar.com).

Reproduction, in part or whole, without the prior written consent of EXAR Corporation is prohibited.

Компания «Океан Электроники» предлагает заключение долгосрочных отношений при поставках импортных электронных компонентов на взаимовыгодных условиях!

Наши преимущества:

- Поставка оригинальных импортных электронных компонентов напрямую с производств Америки, Европы и Азии, а так же с крупнейших складов мира;
- Широкая линейка поставок активных и пассивных импортных электронных компонентов (более 30 млн. наименований);
- Поставка сложных, дефицитных, либо снятых с производства позиций;
- Оперативные сроки поставки под заказ (от 5 рабочих дней);
- Экспресс доставка в любую точку России;
- Помощь Конструкторского Отдела и консультации квалифицированных инженеров;
- Техническая поддержка проекта, помощь в подборе аналогов, поставка прототипов;
- Поставка электронных компонентов под контролем ВП;
- Система менеджмента качества сертифицирована по Международному стандарту ISO 9001;
- При необходимости вся продукция военного и аэрокосмического назначения проходит испытания и сертификацию в лаборатории (по согласованию с заказчиком);
- Поставка специализированных компонентов военного и аэрокосмического уровня качества (Xilinx, Altera, Analog Devices, Intersil, Interpoint, Microsemi, Actel, Aeroflex, Peregrine, VPT, Syfer, Eurofarad, Texas Instruments, MS Kennedy, Miteq, Cobham, E2V, MA-COM, Hittite, Mini-Circuits, General Dynamics и др.);

Компания «Океан Электроники» является официальным дистрибьютором и эксклюзивным представителем в России одного из крупнейших производителей разъемов военного и аэрокосмического назначения «JONHON», а так же официальным дистрибьютором и эксклюзивным представителем в России производителя высокотехнологичных и надежных решений для передачи СВЧ сигналов «FORSTAR».



## JONHON

«JONHON» (основан в 1970 г.)

Разъемы специального, военного и аэрокосмического назначения:

(Применяются в военной, авиационной, аэрокосмической, морской, железнодорожной, горно- и нефтедобывающей отраслях промышленности)

«FORSTAR» (основан в 1998 г.)

ВЧ соединители, коаксиальные кабели,  
кабельные сборки и микроволновые компоненты:

(Применяются в телекоммуникациях гражданского и специального назначения, в средствах связи, РЛС, а так же военной, авиационной и аэрокосмической отраслях промышленности).



Телефон: 8 (812) 309-75-97 (многоканальный)

Факс: 8 (812) 320-03-32

Электронная почта: [ocean@oceanchips.ru](mailto:ocean@oceanchips.ru)

Web: <http://oceanchips.ru/>

Адрес: 198099, г. Санкт-Петербург, ул. Калинина, д. 2, корп. 4, лит. А