



+2.7V to +3.6V-Powered, 1µA Supply Current, 3-Driver/5-Receiver, True RS-232 Transceiver

MAX3212

General Description

The MAX3212 uses Maxim's new proprietary Auto-Shutdown mode to reduce supply current to 1µA. The MAX3212, with 3 RS-232 drivers and 5 RS-232 receivers, is intended for 2.7V to 3.6V-powered EIA/TIA-232E and V.28/V.24 serial interface. True RS-232 levels are maintained across the operating range. A guaranteed data rate of 235kbps provides compatibility with popular software for communicating with personal computers.

Supply current is reduced to 1 µA with Maxim's new AutoShutdown feature. When the MAX3212 does not sense a valid signal level on the receiver inputs, the on-board power supply and drivers shut down. This occurs if the RS-232 cable is disconnected or if the transmitters of the connected peripheral are turned off. The system turns on again when a valid level is applied to any RS-232 receiver input. As a result, the system saves power without changes to the existing software.

A second power-management feature is incorporated to permit automatic shutdown when the RS-232 connection is valid but inactive. In this case, a transition detector facilitates shutdown when the receivers are presented with stationary RS-232 levels for long periods.

Three-state drivers are provided on receiver outputs so that multiple receivers, generally of different interface standards, can be wire-ORed at the UART. The MAX3212 is available in 28-pin SO and SSOP packages.

Applications

- Notebook and Palmtop Computers
- Peripherals
- Instruments
- Battery-Powered Equipment

Ordering Information

PART	TEMP. RANGE	PIN-PACKAGE
MAX3212CWI	0°C to +70°C	28 Wide SO
MAX3212CAI	0°C to +70°C	28 SSOP
MAX3212EWI	-40°C to +85°C	28 Wide SO
MAX3212EAI	-40°C to +85°C	28 SSOP

Pin Configuration appears at end of data sheet.

Features

BETTER THAN BIPOLAR!

- ♦ 1µA Supply Current Using AutoShutdown
- ♦ Operates from Single +2.7V to +3.6V Supply
- ♦ 28-Pin SSOP or Wide SO Packages
- ♦ Meets All EIA/TIA-232E & EIA/TIA-562 Specifications
- ♦ Mouse Driveability—Guaranteed
- ♦ Low-Cost, Surface-Mount External Components
- ♦ 235kbps Guaranteed Data Rate—LapLink™ Compatible
- ♦ +5V Logic Compatible
- ♦ Complementary Receiver Output Always Active
- ♦ Flow-Through Pinout

Typical Operating Circuit

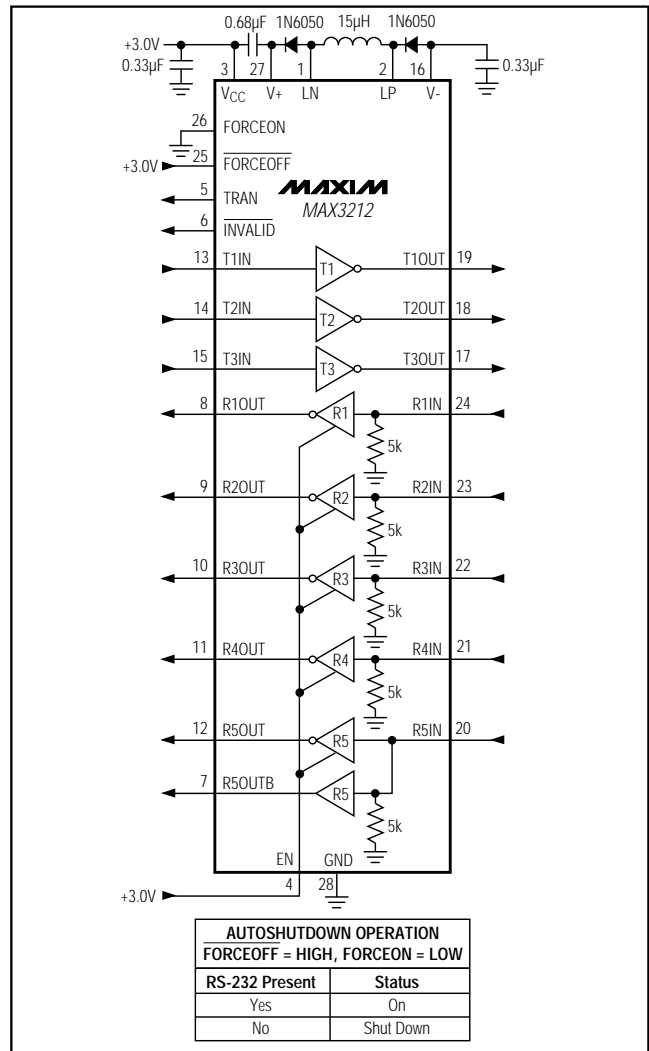

+2.7V to +3.6V-Powered, 1 μ A Supply Current, 3-Driver/5-Receiver, True RS-232 Transceiver

ABSOLUTE MAXIMUM RATINGS

Supply Voltages

V _{CC}	-0.3V to +4.6V
V ₊	(V _{CC} - 0.3V) to +7.4V
V ₋	-7.4V to +2.0V
LN	-0.3V to (V ₊ + 1.0V)
LP	(V ₋ - 1.0V) to (V ₊ + 0.3V)

Input Voltages

T _{IN} , EN, FORCEON, FORCEOFF	-0.3V to +7.0V
R _{IN}	±25V

Output Voltages

T _{OUT}	±15V
R _{OUT} , R5OUTB, INVALID, TRAN	-0.3V to (V ₊ + 0.3V)

Short-Circuit Duration, T_{OUT}.....Continuous

Continuous Power Dissipation (T_A = +70°C)

Wide SO (derate 11.76mW/°C above +70°C).....941mW

SSOP (derate 8.00mW/°C above +70°C)640mW

Operating Temperature Ranges

MAX3212C_I0°C to +70°C

MAX3212E_I-40°C to +85°C

Storage Temperature Range-65°C to +150°C

Lead Temperature (soldering, 10sec)+300°C

Stresses beyond those listed under "Absolute Maximum Ratings" may cause permanent damage to the device. These are stress ratings only, and functional operation of the device at these or any other conditions beyond those indicated in the operational sections of the specifications is not implied. Exposure to absolute maximum rating conditions for extended periods may affect device reliability.

ELECTRICAL CHARACTERISTICS

(V_{CC} = 2.7V to 3.6V, T_A = T_{MIN} to T_{MAX}, unless otherwise noted.)

PARAMETER	CONDITIONS	MIN	TYP	MAX	UNITS
DC CHARACTERISTICS					
Operating Voltage Range	Meets or exceeds EIA/TIA-232E specifications	2.7		3.6	V
V _{CC} Supply Current	All R _{IN} unconnected, FORCEON = GND		1	10	μA
	FORCEOFF = GND		1	10	μA
	FORCEON = FORCEOFF = V _{CC} , no load		1.5	3.0	mA
LOGIC INPUT AND RECEIVER OUTPUTS					
Input Logic Threshold Low	T _{IN} , EN, FORCEON, FORCEOFF			0.3V _{CC} - 0.1	V
Input Logic Threshold High	T _{IN} , EN, FORCEON, FORCEOFF	0.67V _{CC} + 0.1			V
Input Current High	T _{IN} , EN, FORCEON, FORCEOFF			1	μA
Input Current Low	T _{IN} , EN, FORCEON, FORCEOFF			1	μA
Hysteresis	T _{IN} , V _{CC} = 3.3V		0.3		V
Logic Output Voltage Low	I _{OUT} = 1.0mA			0.4	V
Logic Output Voltage High	I _{OUT} = -1.0mA	V _{CC} - 0.5			V
Logic Output Leakage Current	EN = GND, 0V < R _{OUT} < V _{CC}			±10	μA
AUTOSHUTDOWN (FORCEON = GND, FORCEOFF = V _{CC})					
Receiver Input Thresholds, Transmitters Enabled	Figure 4	Positive threshold		3.0	V
		Negative threshold	-3.0		
Receiver Input Thresholds, Transmitters Disabled	1μA supply current, Figure 4	-0.3		0.3	V
INVALID Output Voltage Low	I _{OUT} = 1.0mA			0.4	V
INVALID Output Voltage High	I _{OUT} = -1.0mA	V _{CC} - 0.6			V
Receiver Threshold to Transmitters Enabled, t _{WU}	Figure 4b		250		μs
Receiver Positive or Negative Threshold to Invalid High, t _{INVH}	Figure 4		1		μs
Receiver Positive or Negative Threshold to Invalid Low, t _{INVL}	Figure 4		30		μs

+2.7V to +3.6V-Powered, 1μA Supply Current, 3-Driver/5-Receiver, True RS-232 Transceiver

MAX3212

ELECTRICAL CHARACTERISTICS (continued)

(V_{CC} = 2.7V to 3.6V, T_A = T_{MIN} to T_{MAX}, unless otherwise noted.)

PARAMETER	CONDITIONS	MIN	TYP	MAX	UNITS
EIA/TIA-232E RECEIVERS					
Input Voltage Operating Range		-25		+25	V
Input Voltage Threshold Low		0.4			V
Input Voltage Threshold High				3.0	V
Input Hysteresis			0.7		V
Input Resistance	-15V < V _{IN} < 15V	3	5	7	kΩ
EIA/TIA-232E TRANSMITTERS					
Output Voltage Swing (V _{HIGH} , V _{LOW})	All transmitters loaded with 3kΩ to GND	±5.0	±5.5		V
Output Resistance	V _{CC} = V ₋ = V ₊ = 0V, -2V < T _{OUT} < 2V	300			Ω
EIA/TIA-232E Short-Circuit Current			28	60	mA
MOUSE DRIVEABILITY					
Transmitter Output Voltage	T _{1N} = T _{2IN} = GND, T _{3IN} = V _{CC} , T _{3OUT} loaded with 3kΩ to GND, T _{1OUT} and T _{2OUT} loaded with 5mA	±5			V

TIMING CHARACTERISTICS

(V_{CC} = 2.7V to 3.6V, T_A = T_{MIN} to T_{MAX}, unless otherwise noted.)

PARAMETER	SYMBOL	CONDITIONS	MIN	TYP	MAX	UNITS	
Data Rate		R _L = 3kΩ, C _L = 1000pF, one transmitter switching, 150pF load on each receiver	235	250		kbps	
Receiver Output Enable Time	t _{ER}			70	200	ns	
Receiver Output Disable Time	t _{DR}			420	700	ns	
Transmitter Output Enable Time	t _{ET}	Includes power-supply start-up		250		μs	
Transmitter Output Disable Time	t _{DT}			600		ns	
Receiver Propagation Delay	t _{PHLR}	150pF load		630	2000	ns	
	t _{PLHR}			630	2000		
Receiver Skew		t _{PHL} - t _{PLH}		40		ns	
Transmitter Propagation Delay	t _{PHLT}	2500pF 3kΩ load		800	2000	ns	
	t _{PLHT}			800	2000		
Transmitter Skew		t _{PHL} - t _{PLH}		52		ns	
Transition-Region Slew Rate		R _L = 3kΩ to 7kΩ, measured from +3V to -3V or -3V to +3V	C _L = 50pF to 2500pF	4.0	10	30	V/μs
			C _L = 50pF to 1000pF	6	13	30	
EN High to TRAN Reset Delay				5		μs	
EN High Pulse Width				1		μs	

+2.7V to +3.6V-Powered, 1µA Supply Current, 3-Driver/5-Receiver, True RS-232 Transceiver

Typical Operating Characteristics

(V_{CC} = 3.3V, T_A = +25°C, unless otherwise noted.)

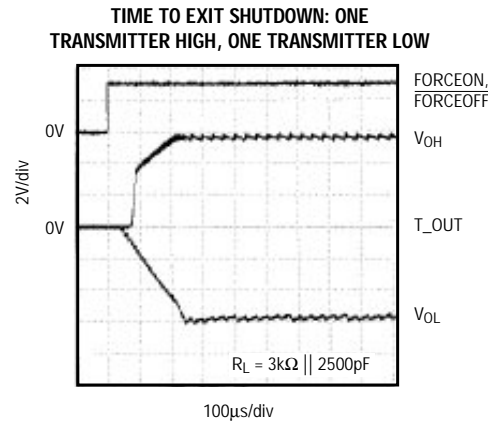
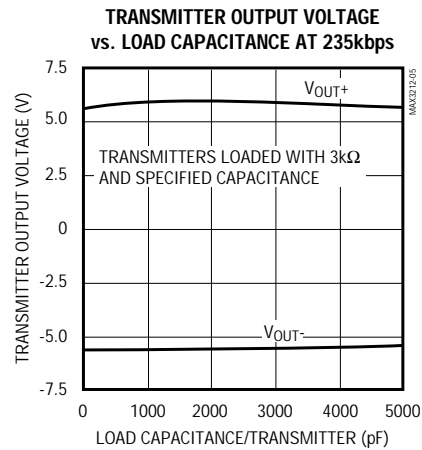
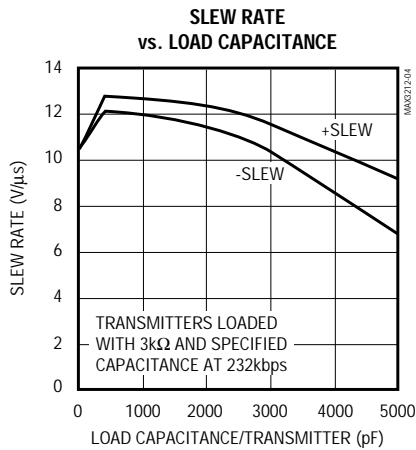
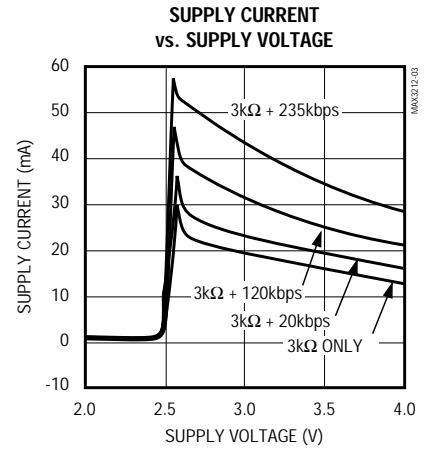
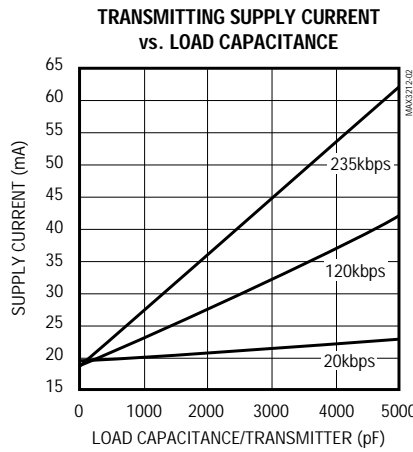
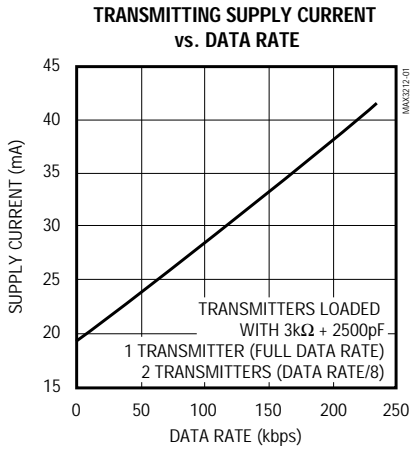

+2.7V to +3.6V-Powered, 1 μ A Supply Current, 3-Driver/5-Receiver, True RS-232 Transceiver

Pin Description

MAX3212

PIN	NAME	FUNCTION
1	LN	Inductor/Diode Connection Point
2	LP	Inductor/Diode Connection Point
3	V _{CC}	Supply Voltage Input, 2.7V to 3.6V
4	EN	Receiver Enable Control. Drive EN low to force receiver outputs into a high-Z state. Drive EN high for normal operation. Cycle EN high then low to reset TRAN. TRAN is always low when EN is high.
5	TRAN	Transition Detection Output. TRAN latches high when a transition occurs on any receiver input while EN is low. Reset by cycling the EN pin high then low.
6	$\overline{\text{INVALID}}$	Output of Invalid Signal Detector. Low if invalid RS-232 levels are present on all receiver inputs, otherwise high.
7	R5OUTB	Complementary Output of R5OUT—always active
8–12	R1OUT–R5OUT	Receiver Outputs. Swing from GND to V _{CC} . High-impedance when EN is low.
13, 14, 15	T1IN, T2IN, T3IN	Transmitter Inputs
16	V-	Negative Supply generated on-board
17, 18, 19	T3OUT, T2OUT, T1OUT	Transmitter Outputs
20–24	R5IN–R1IN	Receiver Inputs
25	$\overline{\text{FORCEOFF}}$	Drive low to shut down transmitters and on-board power supply, overriding all automatic circuitry and FORCEON (see Figure 3).
26	FORCEON	Drive high to override automatic circuitry, keeping transmitters on (see Figure 3). FORCEOFF = high.
27	V+	Positive Supply generated on-board
28	GND	Ground

Detailed Description

The MAX3212 line driver/receiver is intended for 3V-powered EIA/TIA-232E and V.28/V.24 communications interfaces where 3 drivers and 5 receivers are required. The operating voltage range extends from 3.6V down to 2.7V while still maintaining true RS-232 and EIA/TIA-562 transmitter output voltage levels.

The circuit comprises three sections: power supply, transmitters, and receivers. The power-supply section converts the supplied 3V to about $\pm 6.5V$, to provide the voltages necessary for the drivers to meet true RS-232 levels. External components are small and inexpensive.

The transmitters and receivers are guaranteed to operate at data rates of 235kpbs.

The MAX3212 is equipped with Maxim's new proprietary AutoShutdown circuitry. This achieves a supply current of 1 μA by shutting down the device when the RS-232 cable is disconnected or when the connected peripheral transmitters are turned off. While shut down, all receivers can remain active or can be disabled

under logic control. A complementary receiver remains active in all cases, enabling a system incorporating the MAX3212 to remain shut down and still monitor incoming RS-232 activity.

Three-state drivers on all receiver outputs are provided so that multiple receivers, generally of different interface standards, can be wire-ORed at the UART.

Switch-Mode Power Supply

The switch-mode power supply uses a single inductor with two inexpensive diodes and two capacitors to generate $\pm 6.5V$ from the 2.7V to 3.6V input. The *Typical Operating Circuit* shows the complete circuit for the power supply.

Use a 15 μH inductor with a saturation current rating of at least 350mA and under 1 Ω resistance. Use 1N6050 diodes or equivalent. Surface-mount equivalents for the 1N6050 include the Motorola MMBD6050LT1, Philips PMBD6050, and Allegro (formerly Sprague) TMPD6050LT.

For C1 and C2, use ceramic capacitors with values no less than indicated in the *Typical Operating Circuit*. These capacitors determine the ripple on V+ and V-, but

+2.7V to +3.6V-Powered, 1 μ A Supply Current, 3-Driver/5-Receiver, True RS-232 Transceiver

not the absolute voltages. Increasing the size of C1 and C2 increases the time V+ and V- take to reach their final value. Bypass V_{CC} to GND with at least 0.33 μ F close to the MAX3212. Increase this to 4.7 μ F if there are no other V_{CC} supply bypass components less than 6 inches (15cm) away from the MAX3212.

Component suppliers are listed in Table 1.

RS-232 Drivers

All three drivers are identical and deliver EIA/TIA-232E and EIA/TIA-562 output voltage levels when V_{CC} is between 2.7V and 3.6V. When $\overline{\text{FORCEOFF}}$ is driven low or when the AutoShutdown circuitry senses invalid voltage levels at all receiver inputs, the drivers are disabled and the outputs are forced into a high-impedance state.

RS-232 Receivers

The MAX3212 receivers convert RS-232 signals to CMOS-logic output levels. All receivers have one inverting three-state output. Receiver 5 also has a complementary (noninverting) output. In shutdown, all five

inverting receivers can be either active or inactive under logic control.

The complementary output (R5OUTB) is always active, regardless of the state of EN or the part's shutdown status. R5OUTB can monitor RS-232 activity while the other receivers are high impedance. This allows Ring Indicator to be monitored without forward biasing other devices connected to the receiver outputs. This is ideal for systems where the UART's V_{CC} is set to 0V in shutdown. (See Figure 2.)

Enable Control

The EN input has two functions: It allows enabling/disabling of the receivers, and it is used to reset the transition detector.

Driving EN low places five inverting receiver outputs (R_OUT) into a high-impedance state. R5OUTB is always active, regardless of the state of EN or the part's shutdown status (Table 2). EN has no effect on T_OUT.

EN also resets the transition detector. Drive EN high and then low to reset the TRAN output low. TRAN goes high when a transition occurs on any receiver input.

Table 1. Suggested Component Suppliers

MANUFACTURER	PART NUMBER	PHONE	FAX
Diodes			
Allegro	TMPD6050LT	USA (508) 853-5000	USA (508) 853-5049
Motorola	MMBD6050LT1	USA (408) 749-0510	USA (408) 991-7420
Philips	PMBD6050	USA (401) 762-3800	USA (401) 767-4493
Inductors			
Murata-Erie	LQH4N150K-TA	USA (404) 436-1300 Japan (075) 951-9111	USA (404) 684-1541 Japan (075) 955-6526
Sumida	CD43150	USA (708) 956-0666 Japan (03) 3607-5111	USA (708) 956-0702 Japan (03) 3607-5428
TDK	NLC453232T-150K	USA (708) 803-6100 Japan (03) 3278-5111	USA (708) 803-6296 Japan (03) 3278-5358

Table 2. AutoShutdown Logic

RS-232 SIGNAL PRESENT AT RECEIVER INPUT	$\overline{\text{FORCEOFF}}$ INPUT	FORCEON INPUT	$\overline{\text{INVALID}}$ OUTPUT	TRANSCEIVER STATUS
Yes	H	X	H	Normal Operation
No	H	H	L	Normal Operation (Forced On)
No	H	L	L	Shutdown (AutoShutdown)
Yes	L	X	H	Shutdown (Forced Off)
No	L	X	L	Shutdown (Forced Off)

+2.7V to +3.6V-Powered, 1 μ A Supply Current, 3-Driver/5-Receiver, True RS-232 Transceiver

MAX3212

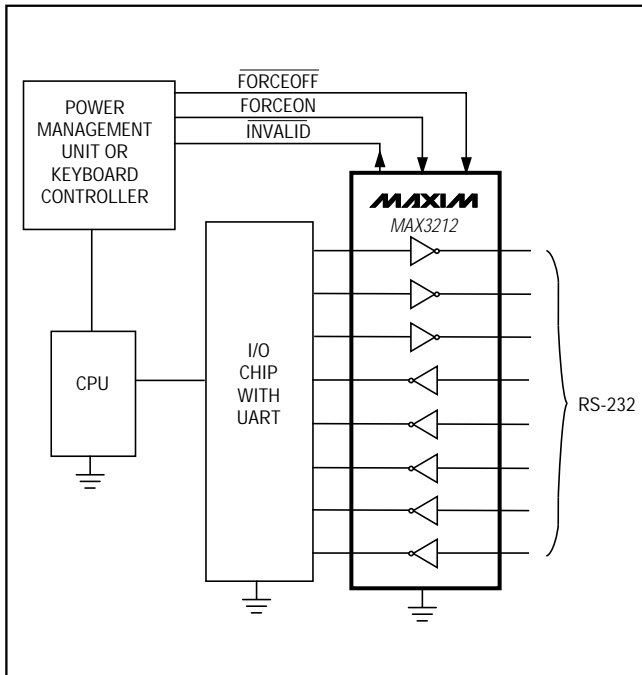

Figure 1. Interface Under Control of PMU

AutoShutdown

A 1 μ A supply current is achieved with Maxim's new AutoShutdown feature, which operates when FORCEON is low and FORCEOFF is high. When the MAX3212 senses no valid signal level on any receiver input for typically 30 μ s, the on-board power supply and drivers shut down. Internal 5k Ω resistors pull the receiver inputs to ground, disabling the transmitters and reducing supply current to 1 μ A when the device is in AutoShutdown mode. This occurs if the RS-232 cable is disconnected or if the connected peripheral transmitters are turned off. The system turns on again when a valid level is applied to any RS-232 receiver input. As a result, the system saves power without changes to the existing BIOS or operating system. When using the AutoShutdown feature, INVALID is high when the device is on and low when the device is shut down. The INVALID output indicates the condition of the receiver inputs; INVALID can be used in any mode.

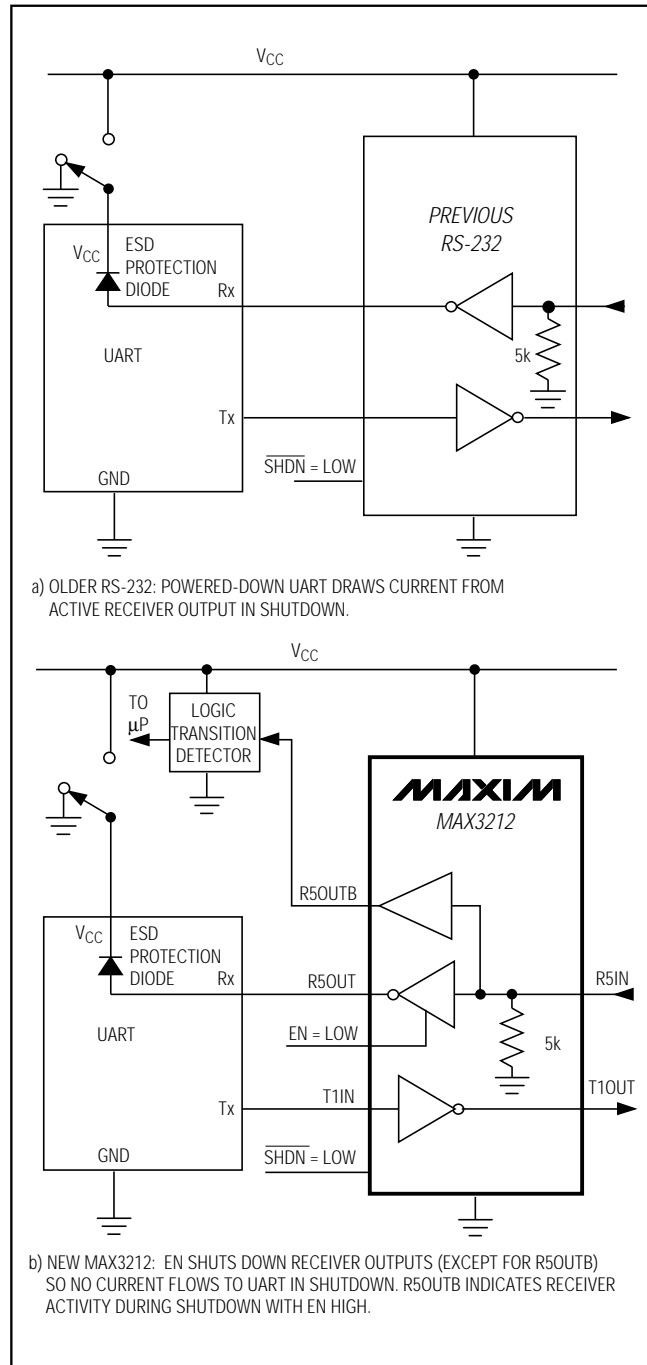

Figure 2. Detection of RS-232 Activity when the UART and Interface Are Shut Down: MAX3212 (b) vs. Previous Transceivers (a)

+2.7V to +3.6V-Powered, 1µA Supply Current, 3-Driver/5-Receiver, True RS-232 Transceiver

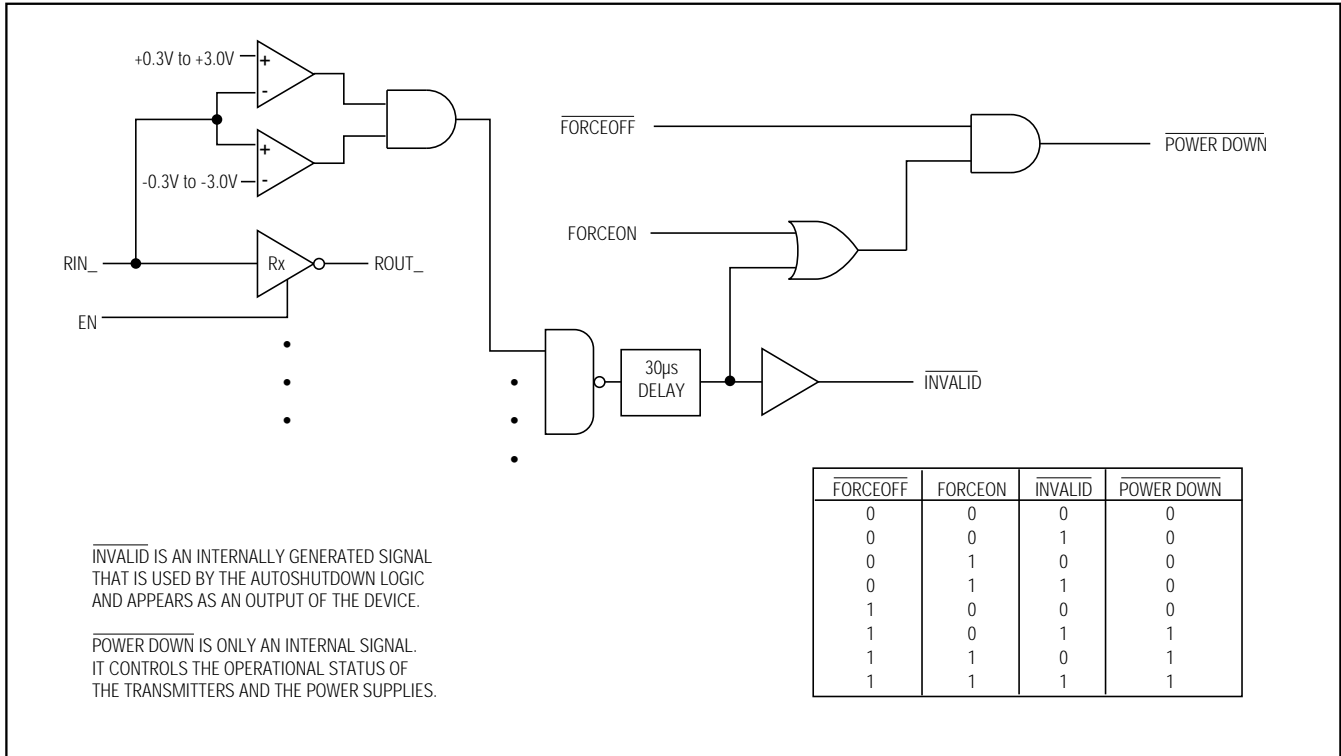

Figure 3. AutoShutdown Logic

Table 2 summarizes the MAX3212 operating modes. FORCEON and FORCEOFF override the automatic circuitry and force the transceiver into its normal operating state or into its low-power standby state. When neither control is asserted, the IC selects between these states automatically based on receiver input levels. Figure 4 depicts valid and invalid RS-232 receiver levels. The MAX3212 shuts down after sensing invalid RS-232 levels for greater than 30 µs, ensuring the AutoShutdown mode is not enabled for slow-moving signals (1V/µs).

A mouse or another system with AutoShutdown may need a period of time to wake up. Figure 5 shows a circuit that forces the transmitters on for 100ms after start-up, allowing enough time for the other system to realize that the MAX3212 system is awake. If the other system outputs valid RS-232 signals within that time, the RS-232 ports on both systems remain enabled.

Transition Detector

The MAX3212 also has an on-board transition detector that monitors activity on the receiver inputs. In systems with a sleep mode, the transition detector output (TRAN) can be used to wake up the system when activity at the receiver inputs is detected. Before putting the system to sleep, set TRAN low by cycling EN high and then low. TRAN remains low as long as no activity is detected on the receiver inputs. When any receiver is toggled, TRAN latches high. Connect TRAN to a microprocessor interrupt, or if the system wakes up periodically TRAN can be polled. Transition detection is useful when valid RS-232 levels are present at the receiver inputs but no data is being sent. For example, if a printer is attached to the serial port but is not in use, the microprocessor senses this and forces the MAX3212 off.

+2.7V to +3.6V-Powered, 1 μ A Supply Current, 3-Driver/5-Receiver, True RS-232 Transceiver

MAX3212

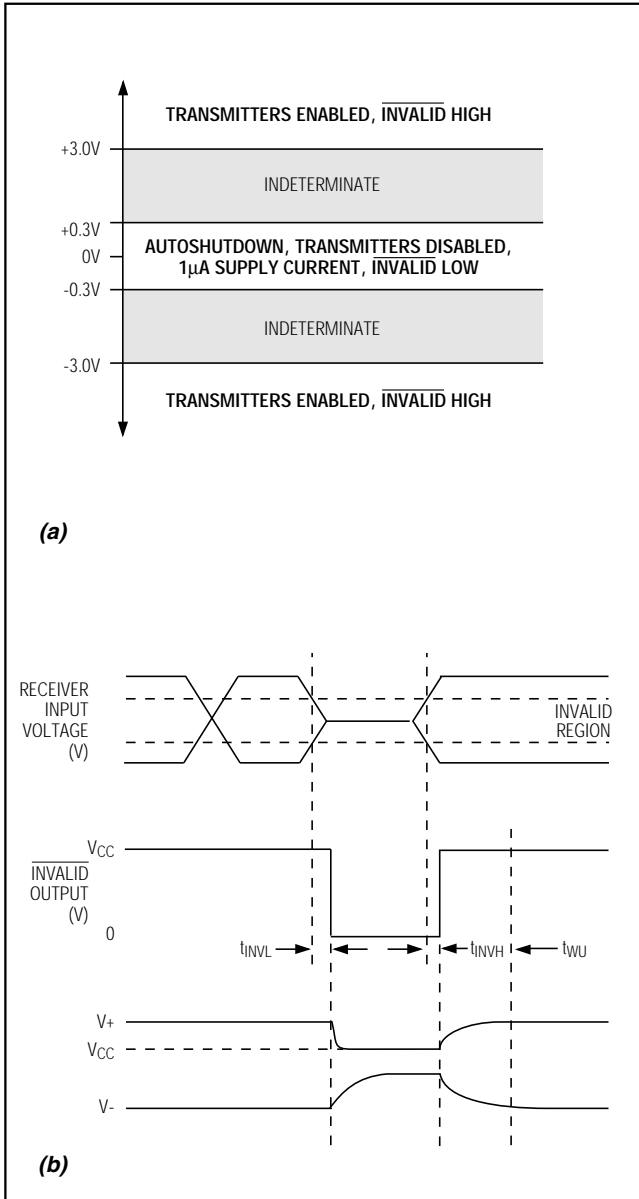

Figure 4. AutoShutdown Trip Levels

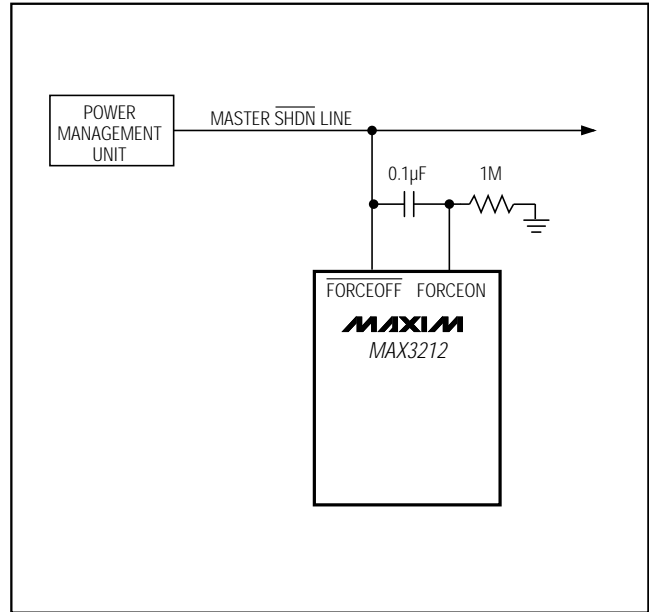

Figure 5. AutoShutdown with Initial Turn-On to Wake Up a Mouse or Another System

+2.7V to +3.6V-Powered, 1µA Supply Current, 3-Driver/5-Receiver, True RS-232 Transceiver

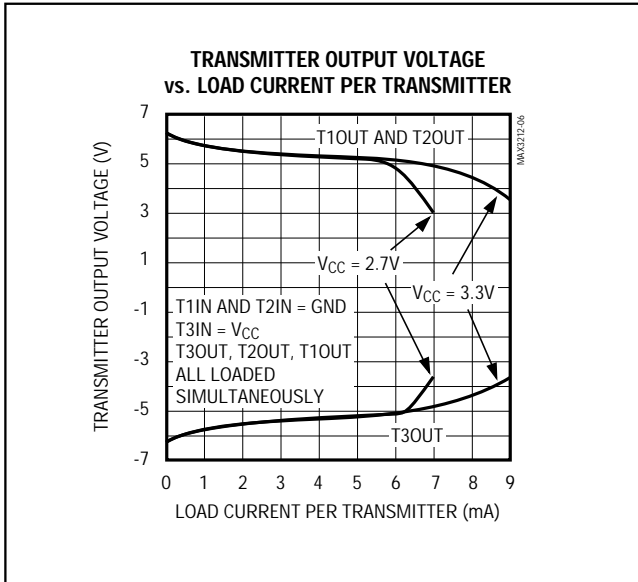

Figure 6. Mouse Emulation Circuit Current

Driving the MAX3212 from 5V Logic
 The MAX3212 can directly interface with various 5V logic families, including ACT and HCT CMOS.

Mouse Driveability
 The MAX3212 has been specifically designed to power serial mice while operating from low-voltage power supplies. It has been tested with samples of ten major mouse models from six manufacturers, including the leading three, Logitech (5 models), Mouse Systems, and Microsoft. The MAX3212 successfully drove all serial mice and met their respective current and voltage requirements.

Figure 6 shows the transmitter output voltages under increasing load current. The MAX3212's switching regulator ensures the transmitters will supply at least ±5V during worst-case load conditions.

____+3V-Powered EIA/TIA-232 and EIA/TIA-562 Transceivers from Maxim

PART	POWER-SUPPLY VOLTAGE (V)	No. OF TRANSMITTERS/RECEIVERS	No. OF RECEIVERS ACTIVE IN SHUTDOWN	GUARANTEED DATA RATE (kbps)	EIA/TIA-232 OR 562	FEATURES
MAX212	3.0 to 3.6	3/5	5	120	232	Drives mice
MAX218	1.8 to 4.25	2/2	2	120	232	Operates directly from batteries without a voltage regulator
MAX562	2.7 to 5.25	3/5	5	230	562	Wide supply range
MAX563	3.0 to 3.6	2/2	2	230	562	0.1µF capacitors
MAX3212	2.7 to 3.6	3/5	5	235	232	AutoShutdown, complementary receiver, drives mice, transient detection
MAX3222	3.0 to 5.5	2/2	2	120	232	0.1µF capacitors
MAX3223	3.0 to 5.5	2/2	2	120	232	0.1µF capacitors, AutoShutdown
MAX3232	3.0 to 5.5	2/2	N/A	120	232	0.1µF capacitors
MAX3241	3.0 to 5.5	3/5	5	120	232	0.1µF capacitors, 2 complementary receivers, drives mice
MAX3243	3.0 to 5.5	3/5	1	120	232	0.1µF capacitors, AutoShutdown, complementary receiver, drives mice

+2.7V to +3.6V-Powered, 1 μ A Supply Current, 3-Driver/5-Receiver, True RS-232 Transceiver

Pin Configuration

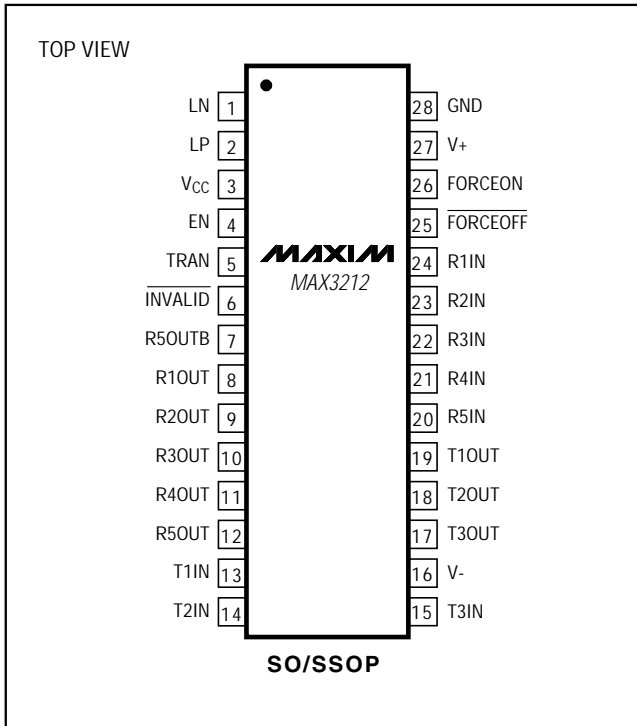

TRANSISTOR COUNT: 1435

MAX3212

+2.7V to +3.6V-Powered, 1µA Supply Current, 3-Driver/5-Receiver, True RS-232 Transceiver

Package Information

SSOP SHRINK SMALL OUTLINE PACKAGE

DIM	INCHES		MILLIMETERS	
	MIN	MAX	MIN	MAX
A	0.068	0.078	1.73	1.99
A1	0.002	0.008	0.05	0.21
B	0.010	0.015	0.25	0.38
C	0.004	0.008	0.09	0.20
D	SEE VARIATIONS			
E	0.205	0.209	5.20	5.38
e	0.0256 BSC		0.65 BSC	
H	0.301	0.311	7.65	7.90
L	0.025	0.037	0.63	0.95
α	0°	8°	0°	8°

DIM	PINS	INCHES		MILLIMETERS	
		MIN	MAX	MIN	MAX
D	14	0.239	0.249	6.07	6.33
D	16	0.239	0.249	6.07	6.33
D	20	0.278	0.289	7.07	7.33
D	24	0.317	0.328	8.07	8.33
D	28	0.397	0.407	10.07	10.33

21-0056A

W PACKAGE SMALL OUTLINE

DIM	INCHES		MILLIMETERS	
	MIN	MAX	MIN	MAX
A	0.093	0.104	2.35	2.65
A1	0.004	0.012	0.10	0.30
B	0.014	0.019	0.35	0.49
C	0.009	0.013	0.23	0.32
E	0.291	0.299	7.40	7.60
e	0.050		1.27	
H	0.394	0.419	10.00	10.65
L	0.016	0.050	0.40	1.27

DIM	PINS	INCHES		MILLIMETERS	
		MIN	MAX	MIN	MAX
D	16	0.398	0.413	10.10	10.50
D	18	0.447	0.463	11.35	11.75
D	20	0.496	0.512	12.60	13.00
D	24	0.598	0.614	15.20	15.60
D	28	0.697	0.713	17.70	18.10

21-0042A

Maxim cannot assume responsibility for use of any circuitry other than circuitry entirely embodied in a Maxim product. No circuit patent licenses are implied. Maxim reserves the right to change the circuitry and specifications without notice at any time.

12 _____ Maxim Integrated Products, 120 San Gabriel Drive, Sunnyvale, CA 94086 (408) 737-7600

Компания «Океан Электроники» предлагает заключение долгосрочных отношений при поставках импортных электронных компонентов на взаимовыгодных условиях!

Наши преимущества:

- Поставка оригинальных импортных электронных компонентов напрямую с производств Америки, Европы и Азии, а так же с крупнейших складов мира;
- Широкая линейка поставок активных и пассивных импортных электронных компонентов (более 30 млн. наименований);
- Поставка сложных, дефицитных, либо снятых с производства позиций;
- Оперативные сроки поставки под заказ (от 5 рабочих дней);
- Экспресс доставка в любую точку России;
- Помощь Конструкторского Отдела и консультации квалифицированных инженеров;
- Техническая поддержка проекта, помощь в подборе аналогов, поставка прототипов;
- Поставка электронных компонентов под контролем ВП;
- Система менеджмента качества сертифицирована по Международному стандарту ISO 9001;
- При необходимости вся продукция военного и аэрокосмического назначения проходит испытания и сертификацию в лаборатории (по согласованию с заказчиком);
- Поставка специализированных компонентов военного и аэрокосмического уровня качества (Xilinx, Altera, Analog Devices, Intersil, Interpoint, Microsemi, Actel, Aeroflex, Peregrine, VPT, Syfer, Eurofarad, Texas Instruments, MS Kennedy, Miteq, Cobham, E2V, MA-COM, Hittite, Mini-Circuits, General Dynamics и др.);

Компания «Океан Электроники» является официальным дистрибьютором и эксклюзивным представителем в России одного из крупнейших производителей разъемов военного и аэрокосмического назначения «JONHON», а так же официальным дистрибьютором и эксклюзивным представителем в России производителя высокотехнологичных и надежных решений для передачи СВЧ сигналов «FORSTAR».



JONHON

«JONHON» (основан в 1970 г.)

Разъемы специального, военного и аэрокосмического назначения:

(Применяются в военной, авиационной, аэрокосмической, морской, железнодорожной, горно- и нефтедобывающей отраслях промышленности)

«FORSTAR» (основан в 1998 г.)

ВЧ соединители, коаксиальные кабели, кабельные сборки и микроволновые компоненты:

(Применяются в телекоммуникациях гражданского и специального назначения, в средствах связи, РЛС, а так же военной, авиационной и аэрокосмической отраслях промышленности).



Телефон: 8 (812) 309-75-97 (многоканальный)

Факс: 8 (812) 320-03-32

Электронная почта: ocean@oceanchips.ru

Web: <http://oceanchips.ru/>

Адрес: 198099, г. Санкт-Петербург, ул. Калинина, д. 2, корп. 4, лит. А