

AS85049/25 and MS3437C Straight EMI/RFI Non-Environmental Backshell



AS85049

B

CONNECTOR DESIGNATOR:

A	AS50151 Series AS34001
	MIL-DTL-26482 Series II
	AS81703 Series III
	MIL-DTL-83723 Series I & III
	40M39569, DEF 5326-3, EN 2997
	EN 3646, ESC 10, ESC 11, LN 29504
	NFC93422 Series HE302 PAN 6432-1, PAN 6432-2, PATT 602

Basic Part Number

Dash Number
(Table II)

M85049/25 - 21 N

Finish / Material

- B** = Black Cadmium / Stainless Steel
- N** = Electroless Nickel / Aluminum
- S** = Passivated / Stainless Steel
- W** = 1,000 Hr. Cadmium Olive Drab over Electroless Nickel / Aluminum
- X** = Aluminum, Nickel Fluorocarbon Polymer
- Z** = Aluminum, Zinc-Nickel, Black
- XS** = Stainless Steel, Nickel Fluorocarbon Polymer
- ZS** = Stainless Steel, Zinc-Nickel, Black

Superseded Part Number

MS3188C 21 N

Basic Part No.

Dash No.

- Finish (Material is Aluminum Only)**
- A** = Cadmium Olive Drab over Nickel
 - C** = Cadmium Olive Drab
 - N** = Electroless Nickel

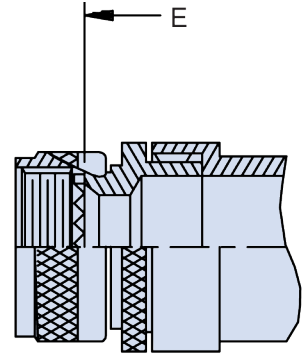

STYLE 2

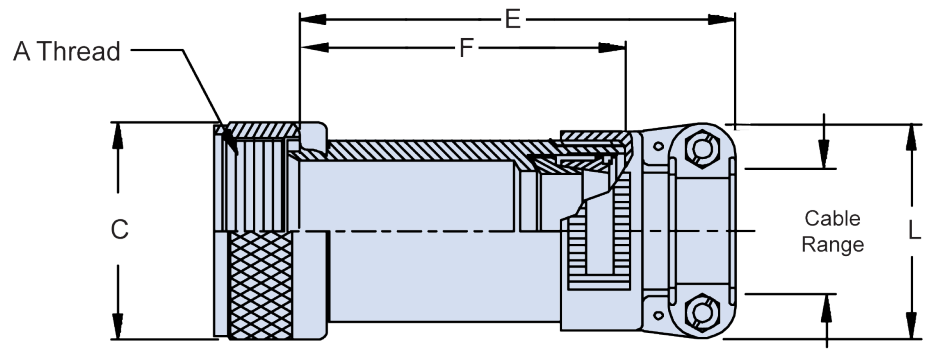

STYLE 1

APPLICATION NOTES

1. For complete dimensions see the applicable Military Specification.
2. When maximum cable entry is exceeded, Style 2 will be supplied.
3. Metric dimensions (mm) are in parentheses.
4. Cable Range is defined as the accommodation range for the wire bundle or cable. Dimensions shown are not intended for inspection criteria.

Dimensions in inches (millimeters) and are subject to change without notice.

© 2013 Glenair, Inc.

U.S. CAGE Code 06324

Printed in U.S.A.



AS85049/25 and MS3437C

Straight EMI/RFI Non-Environmental Backshell

TABLE I: Shell Size

Dash No.	A Thread Class 2B	C Dia Ref
03	.562 - 24 UNEF	.77 (19.6)
08	.500 - 20 UNF	.65 (16.5)
10	.625 - 24 UNEF	.77 (19.6)
12	.750 - 20 UNEF	.40 (10.2)
14	.875 - 20 UNEF	1.02 (25.9)
16	1.000 - 20 UNEF	1.21 (30.7)
18	1.062 - 18 UNEF	1.23 (31.2)
20	1.188 - 18 UNEF	1.36 (34.5)
22	1.313 - 18 UNEF	1.48 (37.6)
24	1.438 - 18 UNEF	1.73 (43.9)
28	1.750 - 18 UNS	1.97 (50.0)
32	2.000 - 18 UNS	2.22 (56.4)
36	2.250 - 16 UN	2.47 (62.7)
40	2.500 - 16 UN	2.72 (69.1)
44	2.750 - 16 UN	2.97 (75.4)
48	3.000 - 16 UN	3.22 (81.8)
61	1.500 - 18 UNEF	1.67 (42.4)

Refer to the
Mil-Spec
for
Complete
Dimensions

TABLE II: Dash Number, Dimensions and Cable Range

Dash No.	Shell Size	Style	E Max	F Ref.	L Max	Cable Range		M85049/42 Ref.
						Min	Max	
01	03	1	2.062 (52.4)	1.027 (26.1)	.957 (24.3)	.125 (3.2)	.250 (6.4)	4
02	03	1	3.063 (77.8)	1.027 (26.1)	.957 (24.3)	.125 (3.2)	.250 (6.4)	4
03	03	2	2.812 (71.4)	1.027 (26.1)	1.145 (29.1)	.250 (6.4)	.437 (11.1)	6
04	03	2	3.812 (96.8)	1.027 (26.1)	1.145 (29.1)	.250 (6.4)	.437 (11.1)	6
05	08	1	2.062 (52.4)	1.027 (26.1)	.957 (24.3)	.125 (3.2)	.250 (6.4)	4
06	08	1	3.062 (77.8)	1.027 (26.1)	.957 (24.3)	.125 (3.2)	.250 (6.4)	4
07	08	2	2.812 (71.4)	1.027 (26.1)	1.145 (29.1)	.250 (6.4)	.437 (11.1)	6
08	08	2	3.812 (96.8)	1.027 (26.1)	1.145 (29.1)	.250 (6.4)	.437 (11.1)	6
09	10	1	2.062 (52.4)	1.027 (26.1)	.957 (24.3)	.125 (3.2)	.312 (7.9)	4
10	10	1	3.062 (77.8)	1.027 (26.1)	.957 (24.3)	.125 (3.2)	.312 (7.9)	4
11	10	2	2.812 (71.4)	1.027 (26.1)	1.145 (29.1)	.250 (6.4)	.437 (11.1)	6
12	10	2	3.812 (96.8)	1.027 (26.1)	1.145 (29.1)	.250 (6.4)	.437 (11.1)	6
13	12	1	2.062 (52.4)	1.027 (26.1)	1.145 (29.1)	.250 (6.4)	.437 (11.1)	6
14	12	1	3.062 (77.8)	1.027 (26.1)	1.145 (29.1)	.250 (6.4)	.437 (11.1)	6
15	12	2	2.812 (71.4)	1.027 (26.1)	1.332 (33.8)	.350 (8.9)	.625 (15.9)	10
16	12	2	3.812 (96.8)	1.027 (26.1)	1.332 (33.8)	.350 (8.9)	.625 (15.9)	10
17	14	1	2.062 (52.4)	1.027 (26.1)	1.332 (33.8)	.350 (8.9)	.575 (14.6)	10
18	14	1	3.062 (77.8)	1.027 (26.1)	1.332 (33.8)	.350 (8.9)	.575 (14.6)	10
19	14	2	2.812 (71.4)	1.059 (26.9)	1.551 (39.4)	.500 (12.7)	.750 (19.1)	12
20	14	2	3.812 (96.8)	1.059 (26.9)	1.551 (39.4)	.500 (12.7)	.750 (19.1)	12
21	16	1	2.062 (52.4)	1.059 (26.9)	1.551 (39.4)	.500 (12.7)	.700 (17.8)	12
22	16	1	3.062 (77.8)	1.059 (26.9)	1.551 (39.4)	.500 (12.7)	.700 (17.8)	12
23	16	2	2.812 (71.4)	1.156 (29.4)	1.770 (45.0)	.625 (15.9)	.937 (23.8)	16
24	16	2	3.812 (96.8)	1.156 (29.4)	1.770 (45.0)	.625 (15.9)	.937 (23.8)	16
25	18	1	2.062 (52.4)	1.027 (26.1)	1.332 (33.8)	.350 (8.9)	.625 (15.9)	10
26	18	1	3.062 (77.8)	1.027 (26.1)	1.332 (33.8)	.350 (8.9)	.625 (15.9)	10
27	18	1	2.062 (52.4)	1.059 (26.9)	1.551 (39.4)	.500 (12.7)	.750 (19.1)	12
28	18	1	3.062 (77.8)	1.059 (26.9)	1.551 (39.4)	.500 (12.7)	.750 (19.1)	12
29	18	2	2.812 (71.4)	1.156 (29.4)	1.770 (45.0)	.625 (15.9)	.937 (23.8)	16
30	18	2	3.812 (96.8)	1.156 (29.4)	1.770 (45.0)	.625 (15.9)	.937 (23.8)	16
31	20	1	3.062 (77.8)	1.027 (26.1)	1.332 (33.8)	.350 (8.9)	.625 (15.9)	10
32	20	1	4.062 (103.2)	1.027 (26.1)	1.332 (33.8)	.350 (8.9)	.625 (15.9)	10
33	20	1	3.062 (77.8)	1.059 (26.9)	1.551 (39.4)	.500 (12.7)	.750 (19.1)	12
34	20	1	4.062 (103.2)	1.059 (26.9)	1.551 (39.4)	.500 (12.7)	.750 (19.1)	12
35	20	2	3.812 (96.8)	1.156 (29.4)	1.770 (45.0)	.625 (15.9)	.937 (23.8)	16
36	20	2	4.812 (122.2)	1.156 (29.4)	1.770 (45.0)	.625 (15.9)	.937 (23.8)	16
37	20	2	3.812 (96.8)	1.375 (34.9)	2.113 (53.7)	.875 (22.2)	1.250 (31.8)	20
38	20	2	4.812 (122.2)	1.375 (34.9)	2.113 (53.7)	.875 (22.2)	1.250 (31.8)	20
39	22	1	3.062 (77.8)	1.027 (26.1)	1.332 (33.8)	.350 (8.9)	.625 (15.9)	10
40	22	1	4.062 (103.2)	1.027 (26.1)	1.332 (33.8)	.350 (8.9)	.625 (15.9)	10
41	22	1	3.062 (77.8)	1.059 (26.9)	1.551 (39.4)	.500 (12.7)	.750 (19.1)	12
42	22	1	4.062 (103.2)	1.059 (26.9)	1.551 (39.4)	.500 (12.7)	.750 (19.1)	12
43	22	1	3.062 (77.8)	1.156 (29.4)	1.770 (45.0)	.625 (15.9)	.937 (23.8)	16
44	22	1	4.062 (103.2)	1.156 (29.4)	1.770 (45.0)	.625 (15.9)	.937 (23.8)	16
45	22	2	3.812 (96.8)	1.375 (34.9)	2.113 (53.7)	.875 (22.2)	1.250 (31.8)	20
46	22	2	4.812 (122.2)	1.375 (34.9)	2.113 (53.7)	.875 (22.2)	1.250 (31.8)	20
47	24	1	3.062 (77.8)	1.059 (26.9)	1.551 (39.4)	.500 (12.7)	.750 (19.1)	12
48	24	1	4.062 (103.2)	1.059 (26.9)	1.551 (39.4)	.500 (12.7)	.750 (19.1)	12
49	24	1	3.062 (77.8)	1.156 (29.4)	1.770 (45.0)	.625 (15.9)	.812 (20.6)	16
50	24	1	4.062 (103.2)	1.156 (29.4)	1.770 (45.0)	.625 (15.9)	.812 (20.6)	16
51	24	1	3.062 (77.8)	1.156 (29.4)	1.770 (45.0)	.625 (15.9)	.937 (23.8)	16
52	24	1	4.062 (103.2)	1.156 (29.4)	1.770 (45.0)	.625 (15.9)	.937 (23.8)	16

Continued on Page B-49

Dimensions in inches (millimeters) and are subject to change without notice.

AS85049/25 and MS3437C Straight EMI/RFI Non-Environmental Backshell



AS85049

B

TABLE II: Continued from Page B-48

Dash No.	Shell Size	Style	E Max	F Ref.	L Max	Cable Range		M85049/42 Ref.
						Min	Max	
53	24	2	3.812 (96.8)	1.375 (34.9)	2.113 (53.7)	.875 (22.2)	1.250 (31.8)	20
54	24	2	4.812 (122.2)	1.375 (34.9)	2.113 (53.7)	.875 (22.2)	1.250 (31.8)	20
55	28	1	3.062 (77.8)	1.059 (26.9)	1.551 (39.4)	.500 (12.7)	.750 (19.1)	12
56	28	1	4.062 (103.2)	1.059 (26.9)	1.551 (39.4)	.500 (12.7)	.750 (19.1)	12
57	28	1	3.062 (77.8)	1.156 (29.4)	1.770 (45.0)	.625 (15.9)	.937 (23.8)	16
58	28	1	4.062 (103.2)	1.156 (29.4)	1.770 (45.0)	.625 (15.9)	.937 (23.8)	16
59	28	1	3.062 (77.8)	1.375 (34.9)	2.113 (53.7)	.875 (22.2)	1.250 (31.8)	20
60	28	1	4.062 (103.2)	1.375 (34.9)	2.113 (53.7)	.875 (22.2)	1.250 (31.8)	20
61	28	1	3.062 (77.8)	1.500 (38.1)	2.363 (60.0)	1.000 (25.4)	1.375 (34.9)	24
62	28	1	4.062 (103.2)	1.500 (38.1)	2.363 (60.0)	1.000 (25.4)	1.375 (34.9)	24
63	32	1	3.062 (77.8)	1.156 (29.4)	1.770 (45.0)	.625 (15.9)	.937 (23.8)	16
64	32	1	4.062 (103.2)	1.156 (29.4)	1.770 (45.0)	.625 (15.9)	.937 (23.8)	16
65	32	1	3.062 (77.8)	1.375 (34.9)	2.113 (53.7)	.875 (22.2)	1.250 (31.8)	20
66	32	1	4.062 (103.2)	1.375 (34.9)	2.113 (53.7)	.875 (22.2)	1.250 (31.8)	20
67	32	1	3.062 (77.8)	1.500 (38.1)	2.363 (60.0)	1.000 (25.4)	1.375 (34.9)	24
68	32	1	4.062 (103.2)	1.500 (38.1)	2.363 (60.0)	1.000 (25.4)	1.375 (34.9)	24
69	32	1	3.062 (77.8)	1.781 (45.2)	2.770 (70.4)	1.250 (31.8)	1.625 (41.3)	28
70	32	1	4.062 (103.2)	1.781 (45.2)	2.770 (70.4)	1.250 (31.8)	1.625 (41.3)	28
71	36	1	4.062 (103.2)	1.375 (34.9)	2.113 (53.7)	.875 (22.2)	1.250 (31.8)	20
72	36	1	5.062 (128.6)	1.375 (34.9)	2.113 (53.7)	.875 (22.2)	1.250 (31.8)	20
73	36	1	4.062 (103.2)	1.500 (38.1)	2.363 (60.0)	1.000 (25.4)	1.375 (34.9)	24
74	36	1	5.062 (128.6)	1.500 (38.1)	2.363 (60.0)	1.000 (25.4)	1.375 (34.9)	24
75	36	1	4.062 (103.2)	1.781 (45.2)	2.770 (70.4)	1.250 (31.8)	1.625 (41.3)	28
76	36	1	5.062 (128.6)	1.781 (45.2)	2.770 (70.4)	1.250 (31.8)	1.625 (41.3)	28
77	36	2	4.942 (125.5)	1.830 (46.5)	3.020 (76.7)	1.437 (36.5)	1.875 (47.6)	32
78	36	2	5.942 (150.9)	1.830 (46.5)	3.020 (76.7)	1.437 (36.5)	1.875 (47.6)	32
79	40	1	4.062 (103.2)	1.375 (34.9)	2.113 (53.7)	.875 (22.2)	1.250 (31.8)	20
80	40	1	5.062 (128.6)	1.375 (34.9)	2.113 (53.7)	.875 (22.2)	1.250 (31.8)	20
81	40	1	4.062 (103.2)	1.500 (38.1)	2.363 (60.0)	1.000 (25.4)	1.375 (34.9)	24
82	40	1	5.062 (128.6)	1.500 (38.1)	2.363 (60.0)	1.000 (25.4)	1.375 (34.9)	24
83	40	1	4.062 (103.2)	1.781 (45.2)	2.770 (70.4)	1.250 (31.8)	1.625 (41.3)	28
84	40	1	5.062 (128.6)	1.781 (45.2)	2.770 (70.4)	1.250 (31.8)	1.625 (41.3)	28
85	40	1	4.062 (103.2)	1.830 (46.5)	3.020 (76.7)	1.437 (36.5)	1.875 (47.6)	32
86	40	1	5.062 (128.6)	1.830 (46.5)	3.020 (76.7)	1.437 (36.5)	1.875 (47.6)	32
87	44	1	4.062 (103.2)	1.375 (34.9)	2.113 (53.7)	.875 (22.2)	1.250 (31.8)	20
88	44	1	5.062 (128.6)	1.375 (34.9)	2.113 (53.7)	.875 (22.2)	1.250 (31.8)	20
89	44	1	4.062 (103.2)	1.500 (38.1)	2.363 (60.0)	1.000 (25.4)	1.375 (34.9)	24
90	44	1	5.062 (128.6)	1.500 (38.1)	2.363 (60.0)	1.000 (25.4)	1.375 (34.9)	24
91	44	1	4.062 (103.2)	1.781 (45.2)	2.770 (70.4)	1.250 (31.8)	1.625 (41.3)	28
92	44	1	5.062 (128.6)	1.781 (45.2)	2.770 (70.4)	1.250 (31.8)	1.625 (41.3)	28
93	44	1	4.062 (103.2)	1.830 (46.5)	3.020 (76.7)	1.437 (36.5)	1.875 (47.6)	32
94	44	1	5.062 (128.6)	1.830 (46.5)	3.020 (76.7)	1.437 (36.5)	1.875 (47.6)	32
95	48	1	4.062 (103.2)	1.375 (34.9)	2.113 (53.7)	.875 (22.2)	1.250 (31.8)	20
96	48	1	5.062 (128.6)	1.375 (34.9)	2.113 (53.7)	.875 (22.2)	1.250 (31.8)	20
97	48	1	4.062 (103.2)	1.500 (38.1)	2.363 (60.0)	1.000 (25.4)	1.375 (34.9)	24
98	48	1	5.062 (128.6)	1.500 (38.1)	2.363 (60.0)	1.000 (25.4)	1.375 (34.9)	24
99	48	1	4.062 (103.2)	1.781 (45.2)	2.770 (70.4)	1.250 (31.8)	1.625 (41.3)	28
100	48	1	5.062 (128.6)	1.781 (45.2)	2.770 (70.4)	1.250 (31.8)	1.625 (41.3)	28
101	48	1	4.062 (103.2)	1.830 (46.5)	3.020 (76.7)	1.437 (36.5)	1.875 (47.6)	32
102	48	1	5.062 (128.6)	1.830 (46.5)	3.020 (76.7)	1.437 (36.5)	1.875 (47.6)	32
103	61	1	3.062 (77.8)	1.059 (26.9)	1.551 (39.4)	.500 (12.7)	.750 (19.1)	12
104	61	1	4.062 (103.2)	1.059 (26.9)	1.551 (39.4)	.500 (12.7)	.750 (19.1)	12

Continued on Page B-50

Dimensions in inches (millimeters) and are subject to change without notice.



AS85049/25 and MS3437C Straight EMI/RFI Non-Environmental Backshell

TABLE II: Continued from Page B-49

Dash No.	Shell Size	Style	E Max	F Ref.	L Max	Cable Range		M85049/42 Ref.
						Min	Max	
105	61	1	3.062 (77.8)	1.156 (29.4)	1.770 (45.0)	.625 (15.9)	.937 (23.8)	16
106	61	1	4.062 (103.2)	1.156 (29.4)	1.770 (45.0)	.625 (15.9)	.937 (23.8)	16
107	61	2	3.812 (96.8)	1.375 (34.9)	2.113 (53.7)	.875 (22.2)	1.250 (31.8)	20
108	61	2	4.812 (122.2)	1.375 (34.9)	2.113 (53.7)	.875 (22.2)	1.250 (31.8)	20
109	61	2	3.812 (96.8)	1.500 (38.1)	2.363 (60.0)	1.000 (25.4)	1.375 (34.9)	24
110	61	2	4.812 (122.2)	1.500 (38.1)	2.363 (60.0)	1.000 (25.4)	1.375 (34.9)	24
111	12	1	2.062 (52.4)	1.027 (26.1)	1.332 (33.8)	.350 (8.9)	.500 (12.7)	10
112	16	1	2.062 (52.4)	1.027 (26.1)	1.145 (29.1)	.250 (6.4)	.437 (11.1)	06
113	16	1	3.062 (77.8)	1.027 (26.1)	1.145 (29.1)	.250 (6.4)	.437 (11.1)	06
114	12	1	2.062 (52.4)	1.027 (26.1)	.957 (24.3)	.125 (3.2)	.312 (7.9)	04
115	12	1	3.062 (77.8)	1.027 (26.1)	.957 (24.3)	.125 (3.2)	.312 (7.9)	04
116	14	1	2.062 (52.4)	1.027 (26.1)	1.145 (29.1)	.250 (6.4)	.437 (11.1)	06
117	14	1	3.062 (77.8)	1.027 (26.1)	1.145 (29.1)	.250 (6.4)	.437 (11.1)	06
118	16	1	2.062 (52.4)	1.027 (26.1)	1.332 (33.8)	.350 (8.9)	.625 (15.9)	10
119	16	1	3.062 (77.8)	1.027 (26.1)	1.332 (33.8)	.350 (8.9)	.625 (15.9)	10
120	18	1	2.062 (52.4)	1.027 (26.1)	.957 (24.3)	.125 (3.2)	.312 (7.9)	04
121	18	1	3.062 (77.8)	1.027 (26.1)	.957 (24.3)	.125 (3.2)	.312 (7.9)	04
122	18	1	2.062 (52.4)	1.027 (26.1)	1.145 (29.1)	.250 (6.4)	.437 (11.1)	06
123	18	1	3.062 (77.8)	1.027 (26.1)	1.145 (29.1)	.250 (6.4)	.437 (11.1)	06
124	20	1	3.062 (77.8)	1.027 (26.1)	1.145 (29.1)	.250 (6.4)	.437 (11.1)	06
125	20	1	4.062 (103.2)	1.027 (26.1)	1.145 (29.1)	.250 (6.4)	.437 (11.1)	06
126	22	1	3.062 (77.8)	1.027 (26.1)	.957 (24.3)	.125 (3.2)	.312 (7.9)	04
127	22	1	4.062 (103.2)	1.027 (26.1)	.957 (24.3)	.125 (3.2)	.312 (7.9)	04
128	22	1	3.062 (77.8)	1.027 (26.1)	1.145 (29.1)	.250 (6.4)	.437 (11.1)	06
129	22	1	4.062 (103.2)	1.027 (26.1)	1.145 (29.1)	.250 (6.4)	.437 (11.1)	06
130	24	1	3.062 (77.8)	1.027 (26.1)	1.332 (33.8)	.350 (8.9)	.625 (15.9)	10
131	24	1	4.062 (103.2)	1.027 (26.1)	1.332 (33.8)	.350 (8.9)	.625 (15.9)	10
132	36	1	4.062 (103.2)	1.059 (26.9)	1.551 (39.4)	.500 (12.7)	.750 (19.1)	12
133	36	1	5.062 (128.6)	1.059 (26.9)	1.551 (39.4)	.500 (12.7)	.750 (19.1)	12
134	40	1	4.062 (103.2)	1.059 (26.9)	1.551 (39.4)	.500 (12.7)	.750 (19.1)	12
135	40	1	5.062 (128.6)	1.059 (26.9)	1.551 (39.4)	.500 (12.7)	.750 (19.1)	12
136	10	1	2.062 (52.4)	1.027 (26.1)	1.145 (29.1)	.250 (6.4)	.375 (9.5)	06
137	10	1	3.062 (77.8)	1.027 (26.1)	1.145 (29.1)	.250 (6.4)	.375 (9.5)	06
138	12	1	2.062 (52.4)	1.027 (26.1)	1.332 (33.8)	.350 (8.9)	.500 (12.7)	10
139	12	1	3.062 (77.8)	1.027 (26.1)	1.332 (33.8)	.350 (8.9)	.500 (12.7)	10
140	20	1	3.062 (77.8)	1.156 (29.4)	1.770 (45.0)	.625 (15.9)	.904 (23.0)	16
141	20	1	4.062 (103.2)	1.156 (29.4)	1.770 (45.0)	.625 (15.9)	.904 (23.0)	16
142	22	1	3.062 (77.8)	1.375 (34.9)	2.113 (53.7)	.875 (22.2)	1.029 (26.1)	20
143	22	1	4.062 (103.2)	1.375 (34.9)	2.113 (53.7)	.875 (22.2)	1.029 (26.1)	20
144	24	1	3.062 (77.8)	1.375 (34.9)	2.113 (53.7)	.875 (22.2)	1.144 (29.1)	20
145	24	1	4.062 (103.2)	1.375 (34.9)	2.113 (53.7)	.875 (22.2)	1.144 (29.1)	20
146	36	1	4.062 (103.2)	1.830 (46.5)	3.020 (76.7)	1.437 (36.5)	1.840 (46.7)	32
147	36	1	5.062 (128.6)	1.830 (46.5)	3.020 (76.7)	1.437 (36.5)	1.840 (46.7)	32
148	36	1	4.062 (103.2)	1.156 (29.4)	1.770 (45.0)	.625 (15.9)	.937 (23.8)	16
149	36	1	5.062 (128.6)	1.156 (29.4)	1.770 (45.0)	.625 (15.9)	.937 (23.8)	16
150	14	1	2.062 (52.4)	1.027 (26.1)	.957 (24.3)	.125 (3.2)	.312 (7.9)	04
151	14	1	3.062 (77.8)	1.027 (26.1)	.957 (24.3)	.125 (3.2)	.312 (7.9)	04
152	16	1	2.062 (52.4)	1.027 (26.1)	.957 (24.3)	.125 (3.2)	.312 (7.9)	04
153	16	1	3.062 (77.8)	1.027 (26.1)	.957 (24.3)	.125 (3.2)	.312 (7.9)	04
154	44	1	4.062 (103.2)	1.156 (29.4)	1.770 (45.0)	.625 (15.9)	.937 (23.8)	16
155	44	1	5.062 (128.6)	1.156 (29.4)	1.770 (45.0)	.625 (15.9)	.937 (23.8)	16
156	40	1	4.062 (103.2)	1.156 (29.4)	1.770 (45.0)	.625 (15.9)	.937 (23.8)	16
157	40	1	5.062 (128.6)	1.156 (29.4)	1.770 (45.0)	.625 (15.9)	.937 (23.8)	16

Dimensions in inches (millimeters) and are subject to change without notice.

Компания «Океан Электроники» предлагает заключение долгосрочных отношений при поставках импортных электронных компонентов на взаимовыгодных условиях!

Наши преимущества:

- Поставка оригинальных импортных электронных компонентов напрямую с производств Америки, Европы и Азии, а так же с крупнейших складов мира;
- Широкая линейка поставок активных и пассивных импортных электронных компонентов (более 30 млн. наименований);
- Поставка сложных, дефицитных, либо снятых с производства позиций;
- Оперативные сроки поставки под заказ (от 5 рабочих дней);
- Экспресс доставка в любую точку России;
- Помощь Конструкторского Отдела и консультации квалифицированных инженеров;
- Техническая поддержка проекта, помощь в подборе аналогов, поставка прототипов;
- Поставка электронных компонентов под контролем ВП;
- Система менеджмента качества сертифицирована по Международному стандарту ISO 9001;
- При необходимости вся продукция военного и аэрокосмического назначения проходит испытания и сертификацию в лаборатории (по согласованию с заказчиком);
- Поставка специализированных компонентов военного и аэрокосмического уровня качества (Xilinx, Altera, Analog Devices, Intersil, Interpoint, Microsemi, Actel, Aeroflex, Peregrine, VPT, Syfer, Eurofarad, Texas Instruments, MS Kennedy, Miteq, Cobham, E2V, MA-COM, Hittite, Mini-Circuits, General Dynamics и др.);

Компания «Океан Электроники» является официальным дистрибьютором и эксклюзивным представителем в России одного из крупнейших производителей разъемов военного и аэрокосмического назначения «JONHON», а так же официальным дистрибьютором и эксклюзивным представителем в России производителя высокотехнологичных и надежных решений для передачи СВЧ сигналов «FORSTAR».



JONHON

«JONHON» (основан в 1970 г.)

Разъемы специального, военного и аэрокосмического назначения:

(Применяются в военной, авиационной, аэрокосмической, морской, железнодорожной, горно- и нефтедобывающей отраслях промышленности)

«FORSTAR» (основан в 1998 г.)

ВЧ соединители, коаксиальные кабели, кабельные сборки и микроволновые компоненты:

(Применяются в телекоммуникациях гражданского и специального назначения, в средствах связи, РЛС, а так же военной, авиационной и аэрокосмической отраслях промышленности).



Телефон: 8 (812) 309-75-97 (многоканальный)

Факс: 8 (812) 320-03-32

Электронная почта: ocean@oceanchips.ru

Web: <http://oceanchips.ru/>

Адрес: 198099, г. Санкт-Петербург, ул. Калинина, д. 2, корп. 4, лит. А