



CUSTOMER PROCUREMENT SPECIFICATION

**Z88C00/01**  
**CMOS SUPER8®**  
**ROMLESS MCU**

**GENERAL DESCRIPTION**

The CMOS Super8® offers new flexibility and sophistication in 8-bit microcontrollers. The Super8 offers all the features necessary for industrial, consumer, and automotive applications with an enhanced feature set in CMOS technology. At the same time, the CMOS Super8 retains full pin-for-pin compatibility with the NMOS Super8. Available in 48-pin DIP, and 44-, 68-pin PLCC, the CMOS Super8 is the last word in general purpose controllers.

The Super8 features a full-duplex, Universal Asynchronous Receiver/Transmitter (UART) with on-chip baud rate generator, on-chip oscillator, and a Direct Memory Access controller (DMA).

**Notes:**

All Signals with a preceding front slash, "/", are active Low, e.g.: B/W (WORD is active Low); /B/W (BYTE is active Low, only).

Power connections follow conventional descriptions below:

Connection	Circuit	Device
Power	V <sub>CC</sub>	V <sub>DD</sub>
Ground	GND	V <sub>SS</sub>

GENERAL DESCRIPTION (Continued)

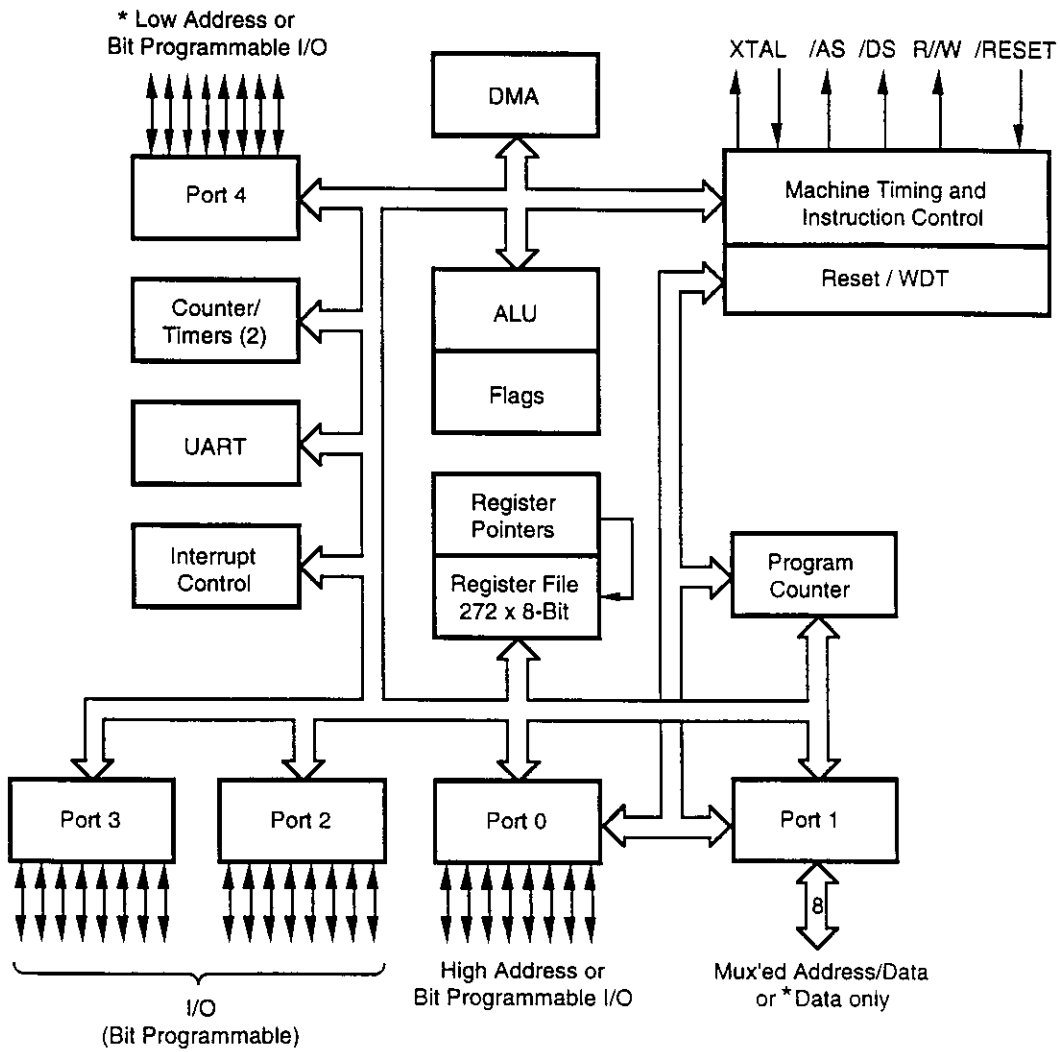

\* Only when used as demux'ed external memory bus.

Functional Block Diagram

GENERAL DESCRIPTION (Continued)

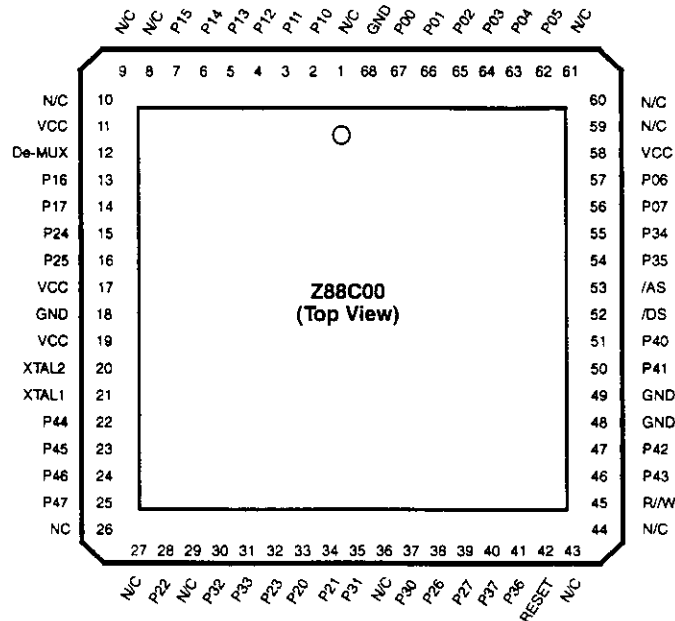

68-Lead PLCC Pin Identification

68-Lead PLCC Pin Assignments

Pin #	Symbol	Function	Direction	Pin #	Symbol	Function	Direction
1	N/C	Not Connected		37	P30	Port 3, Pin 0	In/Output
2-7	P15-10	Port 1, Pins 0,1,2,3,4,5	In/Output	38-39	P27-26	Port 2, Pins 6,7	In/Output
8-10	N/C	Not Connected		40-41	P37-36	Port 3, Pins 7,6	In/Output
11	V <sub>CC</sub>	Power Supply	Input	42	/RESET	RESET	Input
12	De-Mux	De-multiplex Pin	Input	43-44	NC	Not Connected	
13-14	P17-16	Port 1, Pins 6,7	In/Output	45	R/W	READ/WRITE	Output
15-16	P25-24	Port 2, Pins 4,5	In/Output	46-47	P43-42	Port 4, Pins 3,2	In/Output
17	V <sub>CC</sub>	Power Supply	Input	48-49	GND	Ground	Input
18	GND	Ground	Input	50-51	P41-40	Port 4, Pins 1,0	In/Output
19	V <sub>CC</sub>	Power Supply	Input	52	/DS	Data Strobe	Output
20	XTAL2	Crystal Oscillator	Output	53	/AS	Address Strobe	Output
21	XTAL1	Crystal Oscillator	Input	54-55	P35-34	Port 3, Pins 4,5	In/Output
22-25	P47-44	Port 4, Pins 4,5,6,7	In/Output	56-57	P07-06	Port 0, Pins 7,6	In/Output
26-27	N/C	Not Connected		58	V <sub>CC</sub>	Power Supply	Input
28	P22	Port 2, Pin 2	In/Output	59-61	N/C	Not Connected	
29	N/C	Not Connected		62-67	P05-00	Port 0, Pins 5,4,3,2,1,0	In/Output
30-31	P33-32	Port 3, Pins 2,3	In/Output	68	GND	Ground	Input
32-34	P23-21	Port 2, Pins 3,0,1	In/Output				
35	P31	Port 3, Pin 1	In/Output				
36	N/C	Not Connected					

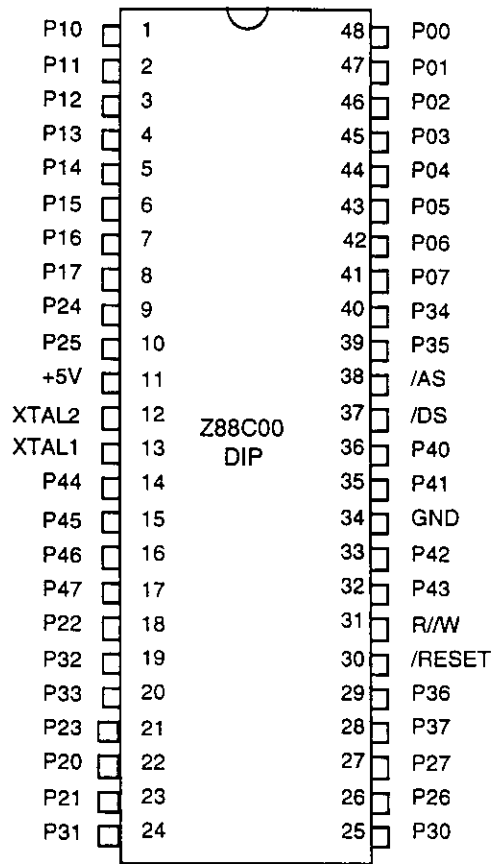

#### 48-Lead DIP Pin Identification

#### 48-Lead DIP Pin Assignments

Pin #	Symbol	Function	Direction	Pin #	Symbol	Function	Direction
1-8	P17-10	Port 1, Pins 0,1,2,3,4,5,6,7	In/Output	28-29	P37-36	Port 3, Pins 7,6	In/Output
9-10	P25-24	Port 2, Pins 4,5	In/Output	30	/RESET	RESET	Input
11	V <sub>CC</sub>	Power Supply	Input	31	R/W	READ/WRITE	Output
12	XTAL2	Crystal Oscillator	Output	32-33	P43-42	Port 4, Pins 3,2	In/Output
13	XTAL1	Crystal Oscillator	Input	34	GND	Ground	Input
14-17	P47-44	Port 4, Pins 4,5,6,7	In/Output	35-36	P41-40	Port 4, Pins 1,0	In/Output
18	P22	Port 2, Pin 2	In/Output	37	/DS	Data Strobe	Output
19-20	P33-32	Port 3, Pins 2,3	In/Output	38	/AS	Address Strobe	Output
21-23	P23-21	Port 2, Pins 3,0,1	In/Output	39-40	P35-34	Port 3, Pins 5,4	In/Output
24-25	P31-30	Port 3, Pins 1,0	In/Output	41-48	P07-00	Port 0, Pins 7,6,5,4,3,2,1,0	In/Output
26-27	P27-26	Port 2, Pins 6,7	In/Output				

## ABSOLUTE MAXIMUM RATINGS

Symbol	Description	Min	Max	Units
$V_{CC}$	Supply Voltage (*)	-0.3	+7.0	V
$T_{STG}$	Storage Temp	-65°	+150°	C
$T_A$	Oper Ambient Temp		†	C

### Notes:

- \* Voltage on all pins with respect to GND.
- † See Ordering Information.

Stress greater than those listed under Absolute Maximum Ratings may cause permanent damage to the device. This is a stress rating only; operation of the device at any condition above those indicated in the operational sections of these specifications is not implied. Exposure to absolute maximum rating conditions for an extended period may affect device reliability.

## STANDARD TEST CONDITIONS

The characteristics listed below apply for standard test conditions as noted. All voltages are referenced to  $V_{SS}$ . Positive current flows into the referenced pin (Standard Test Load).

Standard conditions are:

- $4.5V < V_{CC} < 5.5V$
- GND - 0V
- $-40^{\circ}C < T_A < +105^{\circ}C$

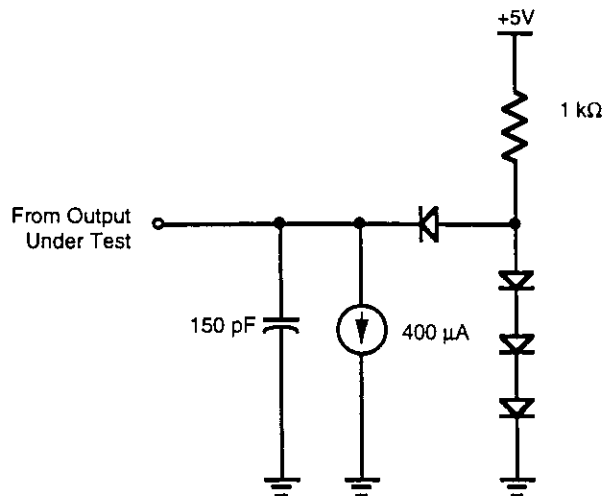

Standard Test Load

## ADDITIONAL FEATURE

### Weak Latches

All input pins on the Super8® will be provided with weak latches. Weak latches on inputs prevent them from floating and reduces unnecessary current flow. Weak latches on inputs are automatically disabled when the corresponding output is configured as open-drain.

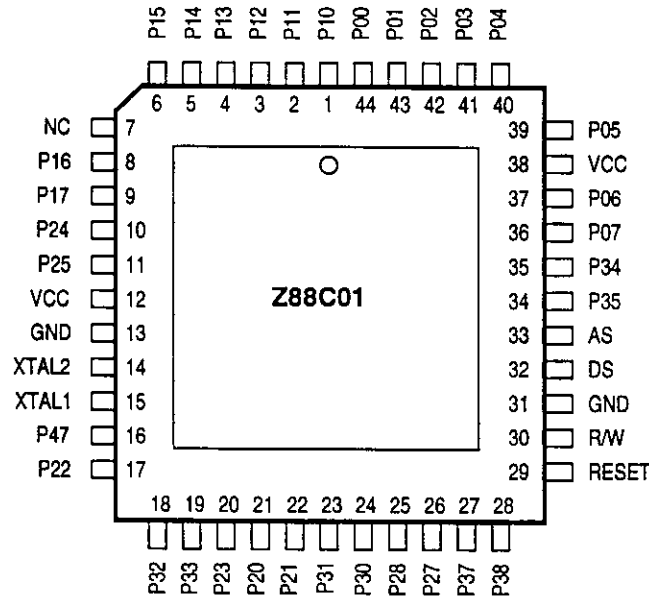

**44-Lead PLCC Pin Identification**

**44-Lead PLCC Pin Identification**

Pin #	Symbol	Function	Direction	Pin #	Symbol	Function	Direction
1-6	P15-10	Port 1, Pins 0,1,2,3,4,5	In/Output	23-24	P31-30	Port 3, Pins 1,0	In/Output
7	N/C	Not Connected		25-26	P27-26	Port 2, Pins 8,7	In/Output
8-9	P17-16	Port 1, Pins 6,7	In/Output	27-28	P37-36	Port 3, Pins 7,8	In/Output
10-11	P25-24	Port 2, Pins 4,5	In/Output	29	/RESET	Reset	Input
12	V <sub>cc</sub>	Power Supply	Input	30	R/W	Read/Write	Output
13	GND	Ground	Input	31	GND	Ground	Input
14	XTAL2	Crystal Oscillator	Output	32	/DS	Data Strobe	Output
15	XTAL1	Crystal Oscillator	Input	33	/AS	Address Strobe	Output
16	P47	Port 4, Pin 7	In/Output	34-35	P35-34	Port 3, Pins 5,4	In/Output
17	P22	Port 2, Pin 2	In/Output	36-37	P07-06	Port 0, Pins 7,6	In/Output
18-19	P33-32	Port 3, Pins 2,3	In/Output	38	V <sub>cc</sub>	Power Supply	Input
20-22	P23-21	Port 2, Pins 3,0,1	In/Output	39-44	P05-00	Port 0, Pins 5,4,3,2,1,0	In/Output

## AC ELECTRICAL CHARACTERISTICS

External I/O or Memory Read and Write Timing

Number	Symbol	Parameter	Normal		Extended	
			Min	Max	Min	Max
1	TdA(AS)	Address valid to /AS Rise Delay	25		50	
2	ThAS(A)	/AS Rise to Address Valid Hold Time	35		85	
3	TdAS(DI)	/AS Rise to Data In Required Valid Delay		150		335
4	TwAS	/AS Low Width	35		85	
5	TdAZ (DSR)	Address Float to /DS (Read)	0		0	
6	TwDSR	/DS (Read) Low Width	125		275	
7	TwDSW	/DS (Write) Low Width	65		165	
8	TdDSR (DI)	/DS (Read) to Data In Required Valid Delay		80		225
9	ThDSR(DI)	/DS Rise (Read) to Data In Hold Time	0		0	
10	TdDS (A)	/DS Rise to Address Active Delay	20		70	
11	TdDA (AS)	/DS Rise to /AS Delay	30		80	
12	TdRW (AS)	R/W to AS Rise Delay	20		70	
13	TdDS (RW)	DS Rise to R/W Valid Delay	40		90	
14	TdDO (DSW)	Data Out to /DS (Write) Delay	10		50	
15	ThDSW (DO)	/DS Rise (Write) to Data Out Hold Time	20		85	
16	TdA (DI)	Address to Data In Required Valid Delay		205		385
17	TdAS (DSR)	/AS Rise to D/S (Read) Delay	50		95	
19	TdDM (AS)	/DM to /AS Rise Delay	28		70	
20	TdDS (DM)	/DS Rise to /DM Valid Delay	33		85	
21	ThDS (A)	/DS Rise to Address Valid Hold Time	36		90	
22	TwW	Wait Width (One Wait) Window	[1]		[1]	
23	TdAS (W)	/AS Rise to Wait Delay		90		335

**Notes:**

[1] Not characterized function, guaranteed by design.

The value of TsDI (DSR) has been measured for the NMOS part as mentioned below as TsDI (DSR) old. This "old" value needs to be relaxed as to the value described as

TsDI (DSR) new. This new value will allow the customer to use external memories with slower access times that immediately translates in lower cost.

**DC CHARACTERISTICS**

Symbol	Parameter	Min	Max	Unit	Condition
$V_{CH}$	Clock Input High Voltage	3.8	$V_{CC}$	V	Driven by External Clock Generator
$V_{CL}$	Clock Input Low Voltage	-0.3	0.8	V	Driven by External Clock Generator
$V_{IH}$	Input High Voltage	$0.7 V_{CC}$	$V_{CC}$	V	
$V_{IL}$	Input Low Voltage	-0.3	$0.15 V_{CC}$	V	
$V_{RH}$	Reset Input High Voltage	3.8	$V_{CC}$	V	
$V_{RL}$	Reset Input Low Voltage	-0.3	0.8	V	
$V_{OH}$	Output High Voltage	2.4		V	$I_{OH} = -400 \mu A$
$V_{OL}$	Output Low Voltage		0.4	V	$I_{OL} = +4.0 \text{ mA}$
$V_{IL}$	Input Leakage	-10	10	$\mu A$	
$I_{OL}$	Output Leakage	-10	10	$\mu A$	
$I_{IR}$	Reset Input Current		-50	$\mu A$	
$I_{CC}$	$V_{CC}$ Standby Current		90	mA	[1]

**Notes:**

Estimated Values

[1] In this case all outputs and I/O pins are floating.



## INTERLOCKED MODE HANDSHAKE TIMING

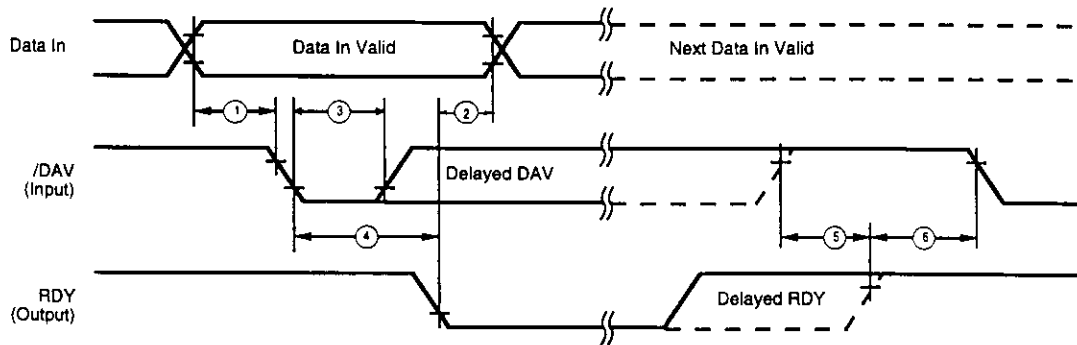

Input Handshake Timing Fully Interlocked Mode

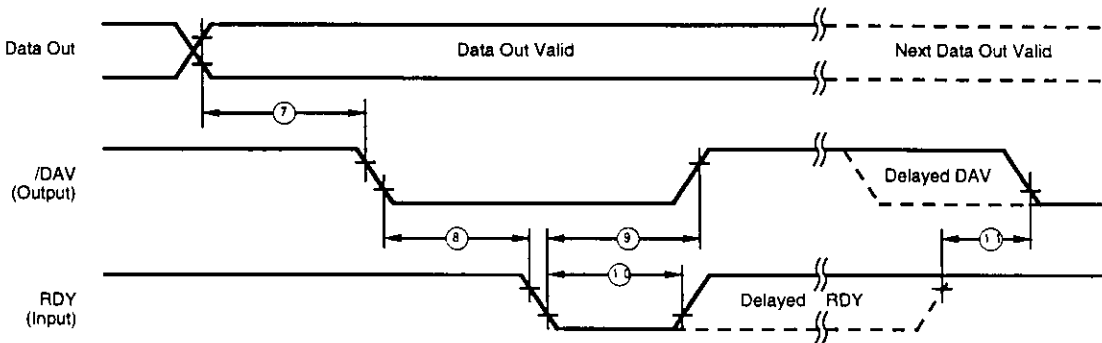

Output Handshake Timing Fully Interlocked Mode

## AC ELECTRICAL CHARACTERISTICS

### Interlocked Mode Handshake Timing

No.	Symbol	Parameter	Notes (Data Direction)
1	TsDI (DAV)	Data in Setup Time to /DAV	In
2	ThRDY (DI)	RDY to Data in Hold Time	In
3	TwDAV	/DAV Width	In
4	TdDAV (RDY)	/DAV to RDY Delay	In
5	TwDAV (RDY)	DAV^ to RDY Wait Time	In
6	TdRDY (DAV)	RDY^ to /DAV Delay	In
7	TdD0 (DAV)	Data Out to /DAV Delay	Out
8	TdDAVd (RDY)	DAV to RDY Delay	Out
9	TdRDY (DAV)	RDY to /DAV^ Delay	Out
10	TwRDY	RDY Width	Out
11	TwRDY (DAV)	RDY^ to /DAV Wait Time	Out

20 MHZ NORMAL TIMING

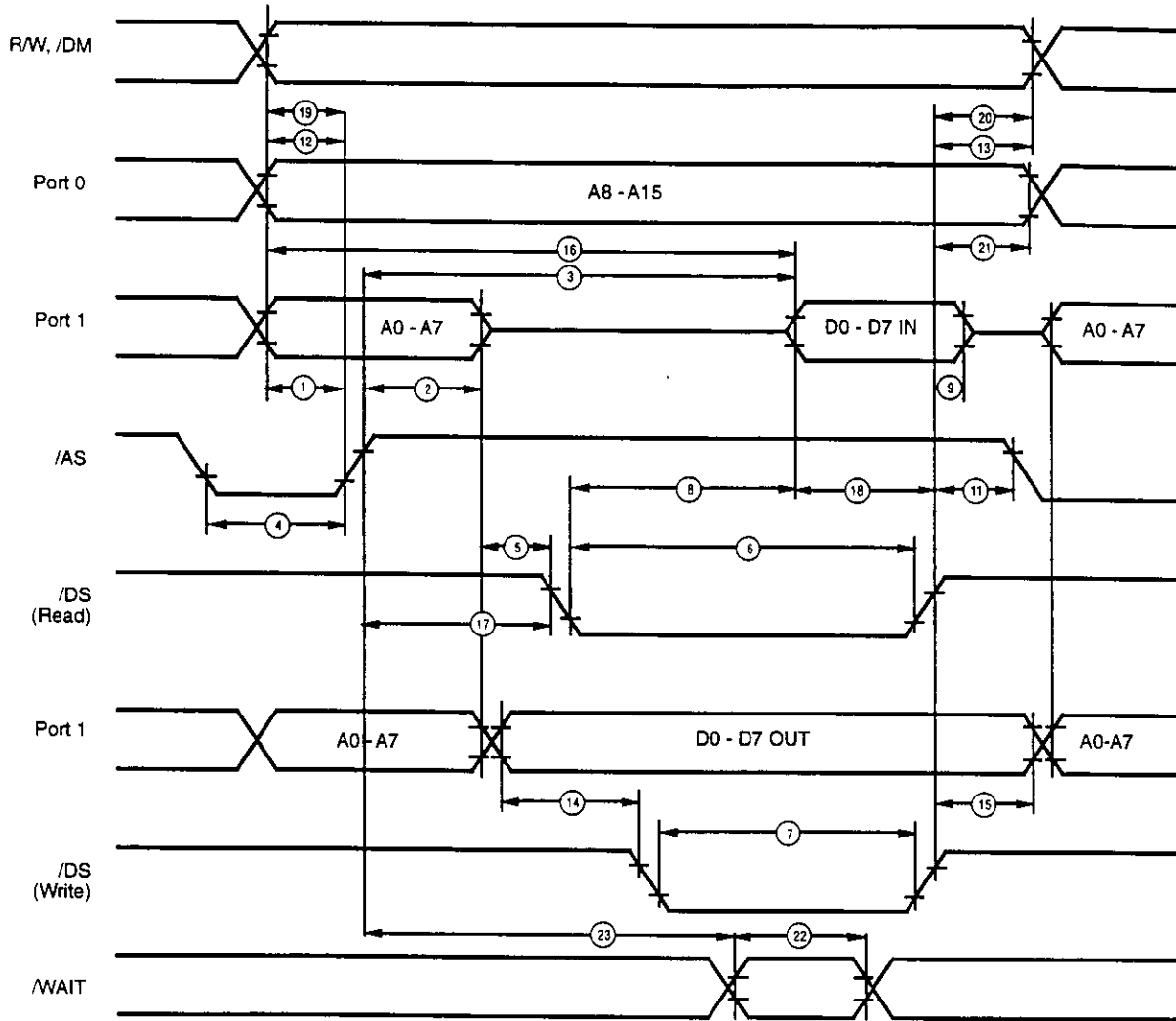

External Memory Read And Write

## Z88C00 ERRATA

1. Handshake Port 4  
Input handshake (strobe and fully interlocked mode) with DMA is not functional.
2. UART Receive  
Upon receiving a character, the RCA (receive character available) interrupt is serviced twice. The time between two consecutive interrupts at 14 MHz is 53  $\mu$ s. Although the UIO is read, which normally should clear the interrupt source, the RCA interrupt is asserted twice.
3. TTL Levels  
 $V_{IH}$ ,  $V_{IL}$  do not meet the TTL specification when the port is used as control inputs for the counter/timers, UART, handshake, external wait and interrupts. Instead  $V_{IH} = 0.7 V_{CC}$  and  $V_{IL} = 0.15 V_{CC}$ .
4. DMA Usage  
No DMA can be performed to external memories if the wait feature (hardware wait and software wait) is used.
5. Reset Software Sequence  
After a hardware reset, program the POM register before the PM register.
6. Counter/Timers  
To obtain a 2.5 MHz signal from the counter/timers, load the Counter/Timer registers with FFFFH and count up. The equivalent operations for the NMOS part to obtain the 2.5 MHz signal is to load the counter/timers with 0000H and count down.

---

### Low Margin:

Customer is advised that this product does not meet Zilog's internal guardbanded test policies for the specification requested and is supplied on an exception basis. Customer is cautioned that delivery may be uncertain and that, in addition to all other limitations on Zilog liability

stated on the front and back of the acknowledgement, Zilog makes no claim as to quality and reliability under the CPS. The product remains subject to standard warranty for replacement due to defects in materials and workmanship.

---

© 1993 by Zilog, Inc. All rights reserved. No part of this document may be copied or reproduced in any form or by any means without the prior written consent of Zilog, Inc. The information in this document is subject to change without notice. Devices sold by Zilog, Inc. are covered by warranty and patent indemnification provisions appearing in Zilog, Inc. Terms and Conditions of Sale only. Zilog, Inc. makes no warranty, express, statutory, implied or by description, regarding the information set forth herein or regarding the freedom of the described devices from intellectual property infringement. Zilog, Inc. makes no warranty of merchantability or fitness for any purpose. Zilog, Inc. shall not be responsible for any errors that may appear in this document. Zilog, Inc. makes no commitment to update or keep current the information contained in this document.

Zilog's products are not authorized for use as critical components in life support devices or systems unless a specific written agreement pertaining to such intended use is executed between the customer and Zilog prior to use. Life support devices or systems are those which are intended for surgical implantation into the body, or which sustains life whose failure to perform, when properly used in accordance with instructions for use provided in the labeling, can be reasonably expected to result in significant injury to the user.

Zilog, Inc. 210 East Hacienda Ave.  
Campbell, CA 95008-6600  
Telephone (408) 370-8000  
Telex 910-338-7621  
FAX 408 370-8056

## STROBE MODE HANDSHAKE TIMING

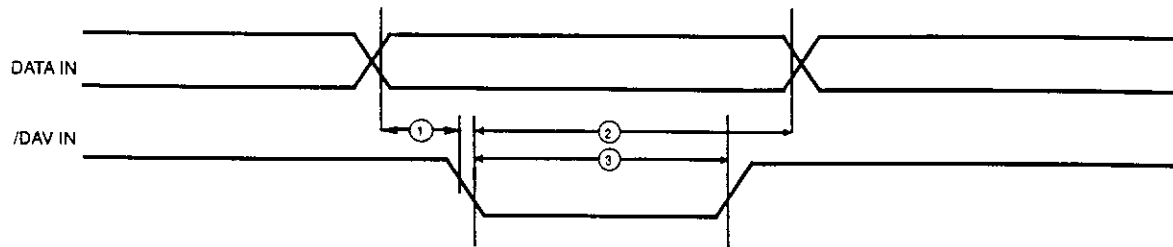

Input Handshake Timing Strobed Mode

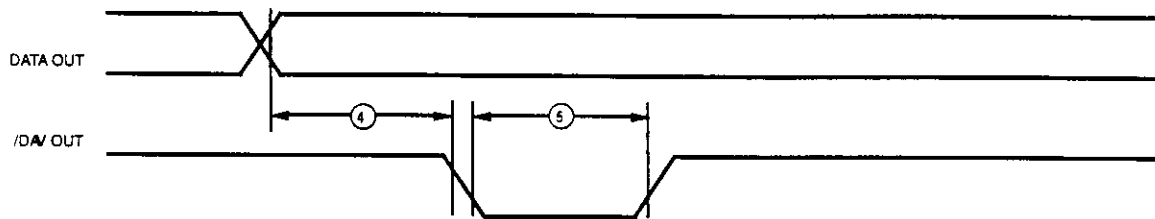

Output Handshake Timing Strobed Mode

## AC ELECTRICAL CHARACTERISTICS

### Strobe Mode Handshake Timing

No.	Symbol	Parameter	Notes (Data Direction)
1	$T_{sDI}(\text{DAV})$	Data In to Setup Time /DAV	In
2	$T_{hDAV}(\text{DI})$	Data in Hold Time	In
3	$T_{wDAV}$	/DAV Width	In
4	$T_{dDO}(\text{DAV})$	Data Out to /DAV Delay	Out
5	$T_{wDAV}$	Data Available Width	Out

Компания «Океан Электроники» предлагает заключение долгосрочных отношений при поставках импортных электронных компонентов на взаимовыгодных условиях!

Наши преимущества:

- Поставка оригинальных импортных электронных компонентов напрямую с производств Америки, Европы и Азии, а так же с крупнейших складов мира;
- Широкая линейка поставок активных и пассивных импортных электронных компонентов (более 30 млн. наименований);
- Поставка сложных, дефицитных, либо снятых с производства позиций;
- Оперативные сроки поставки под заказ (от 5 рабочих дней);
- Экспресс доставка в любую точку России;
- Помощь Конструкторского Отдела и консультации квалифицированных инженеров;
- Техническая поддержка проекта, помощь в подборе аналогов, поставка прототипов;
- Поставка электронных компонентов под контролем ВП;
- Система менеджмента качества сертифицирована по Международному стандарту ISO 9001;
- При необходимости вся продукция военного и аэрокосмического назначения проходит испытания и сертификацию в лаборатории (по согласованию с заказчиком);
- Поставка специализированных компонентов военного и аэрокосмического уровня качества (Xilinx, Altera, Analog Devices, Intersil, Interpoint, Microsemi, Actel, Aeroflex, Peregrine, VPT, Syfer, Eurofarad, Texas Instruments, MS Kennedy, Miteq, Cobham, E2V, MA-COM, Hittite, Mini-Circuits, General Dynamics и др.);

Компания «Океан Электроники» является официальным дистрибьютором и эксклюзивным представителем в России одного из крупнейших производителей разъемов военного и аэрокосмического назначения «JONHON», а так же официальным дистрибьютором и эксклюзивным представителем в России производителя высокотехнологичных и надежных решений для передачи СВЧ сигналов «FORSTAR».



## JONHON

«JONHON» (основан в 1970 г.)

Разъемы специального, военного и аэрокосмического назначения:

(Применяются в военной, авиационной, аэрокосмической, морской, железнодорожной, горно- и нефтедобывающей отраслях промышленности)

«FORSTAR» (основан в 1998 г.)

ВЧ соединители, коаксиальные кабели, кабельные сборки и микроволновые компоненты:

(Применяются в телекоммуникациях гражданского и специального назначения, в средствах связи, РЛС, а так же военной, авиационной и аэрокосмической отраслях промышленности).



Телефон: 8 (812) 309-75-97 (многоканальный)

Факс: 8 (812) 320-03-32

Электронная почта: [ocean@oceanchips.ru](mailto:ocean@oceanchips.ru)

Web: <http://oceanchips.ru/>

Адрес: 198099, г. Санкт-Петербург, ул. Калинина, д. 2, корп. 4, лит. А