



ON Semiconductor®

<http://onsemi.com>

LV52204MU

Bi-CMOS IC

LED Boost Driver with PWM and 1-Wire Dimming

Overview

The LV52204MU is a high voltage boost driver for LED drive. LED current is set by the external resistor R1 and LED dimming can be done by changing FB voltage with PWM or 1-Wire.

Features

- Operating Voltage from 2.7V to 5.5V
- Integrated 40V MOSFET
- 1-Wire 32 level digital and PWM dimming
- 600kHz Switching Frequency

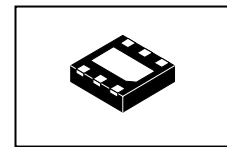

UDFN6 2 × 2 , 0.65P

Typical Applications

- LED Display Backlight Control

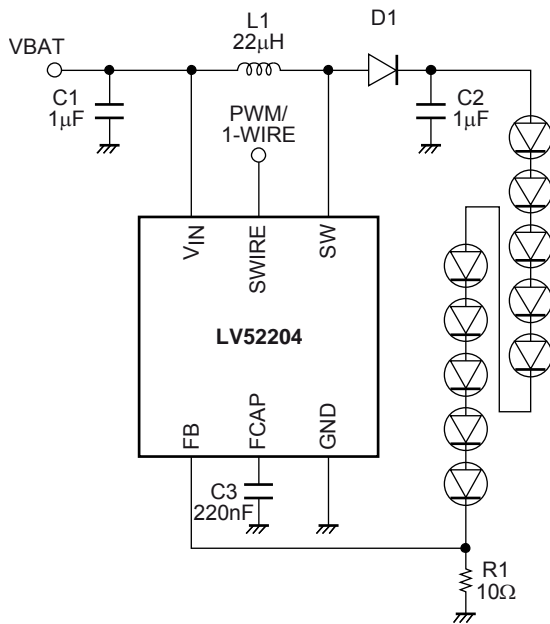

ORDERING INFORMATION

See detailed ordering and shipping information on page 16 of this data sheet.

LV52204MU

Specifications

Absolute Maximum Ratings at $T_a = 25^\circ\text{C}$

Parameter	Symbol	Conditions	Ratings	Unit
Maximum supply voltage	$V_{CC\text{ max}}$	V_{CC}	5.5	V
Maximum pin voltage1	$V1\text{ max}$	SW	40	V
Maximum pin voltage2	$V2\text{ max}$	Other pin	5.5	V
Allowable power dissipation	$Pd\text{ max}$	$T_a = 25^\circ\text{C}^*1$	2.05	W
Operating temperature	T_{opr}		-30 to +85	$^\circ\text{C}$
Storage temperature	T_{stg}		-55 to +125	$^\circ\text{C}$

*1 Mounted on a specified board: 70mm×50mm×1.2mm (4 layer glass epoxy)

Caution 1) Absolute maximum ratings represent the values which cannot be exceeded for any length of time.

Caution 2) Even when the device is used within the range of absolute maximum ratings, as a result of continuous usage under high temperature, high current, high voltage, or drastic temperature change, the reliability of the IC may be degraded. Please contact us for the further details.

Stresses exceeding those listed in the Maximum Ratings table may damage the device. If any of these limits are exceeded, device functionality should not be assumed, damage may occur and reliability may be affected.

Recommendation Operating Condition at $T_a = 25^\circ\text{C}$

Parameter	Symbol	Conditions	Ratings	Unit
Supply voltage range1	$V_{CC\text{ op}}$	V_{CC}	2.7 to 5.5	V
PWM frequency	F_{pwm}	PWM MODE	300 to 100k	Hz

Functional operation above the stresses listed in the Recommended Operating Ranges is not implied. Extended exposure to stresses beyond the Recommended Operating Ranges limits may affect device reliability.

Electrical Characteristics Analog block at $T_a = 25^\circ\text{C}$, $V_{CC} = 3.6\text{V}$, unless otherwise specified

Parameter	Symbol	Conditions	Ratings			Unit
			min	typ	max	
Standby current dissipation	I_{CC1}	SHUTDOWN		0	5	μA
DC/DC current dissipation	I_{CC2}	$V_{OUT} = 30\text{V}$, $I_{LED} = 20\text{mA}$			1	mA
FB voltage	V_{fb}	PWM duty 100%	0.19	0.2	0.21	V
FB pin leak current	I_{fb}				1	μA
OVP voltage	V_{ovp}	SW	37	38	39	V
SWOUT ON resistance	R_{on}	$I_L = 100\text{mA}$		700		$\text{m}\Omega$
NMOS switch current limit	I_{LIM}	$V_{fb} = 200\text{mV}$		0.7		A
OSC frequency	F_{osc}			600		kHz
High level input voltage	V_{INH}	SWIRE	1.5		V_{CC}	V
Low level input voltage	V_{INL}	SWIRE	0		0.4	V
Under voltage lockout	V_{uvlo}	V_{IN} falling		2.2		V
SWIRE output voltage for Acknowledge	V_{ack}	$R_{pullup} = 15\text{k}\Omega$			0.4	V

Product parametric performance is indicated in the Electrical Characteristics for the listed test conditions, unless otherwise noted. Product performance may not be indicated by the Electrical Characteristics if operated under different conditions.

LV52204MU

Recommended SWIRE Timing at $T_a = 25^\circ\text{C}$, $V_{CC} = 3.6\text{V}$, unless otherwise specified

Parameter	Symbol	Conditions	Ratings			Unit
			min	typ	max	
SWIRE setup time1 from shutdown	Ton1	PWM duty more than 2%, $V_{IN} \geq 3.3\text{V}$, -30°C to 85°C *2	2			μs
SWIRE setup time2 from shutdown	Ton2		20			μs
SWIRE mode selectable time	Tsel		1		2.2	ms
SWIRE delay time to start digital mode detection	Tw0		100			μs
SWIRE low time to switch to digital mode	Tw1		260			μs
SWIRE low time to shutdown	Toff		8.9			ms
SWIRE start time for digital mode programming	Tstart		2			μs
SWIRE end time for digital mode programming	Tend		2		360	μs
SWIRE High time of bit 0	Th0	Bit detection = 0	2		180	μs
SWIRE Low time of bit 0	Tl0	Bit detection = 0	$T_{h0} \times 2$		360	μs
SWIRE High time of bit 1	Th1	Bit detection = 1	$T_{l1} \times 2$		360	μs
SWIRE Low time of bit1	Tl1	Bit detection = 1	2		180	μs
DCDC startup delay	Tdel			2		ms
Delay time of Acknowledge	Tackd				2	μs
Duration of Acknowledge	Tack				512	μs

*2 Guaranteed by design

Block Diagram

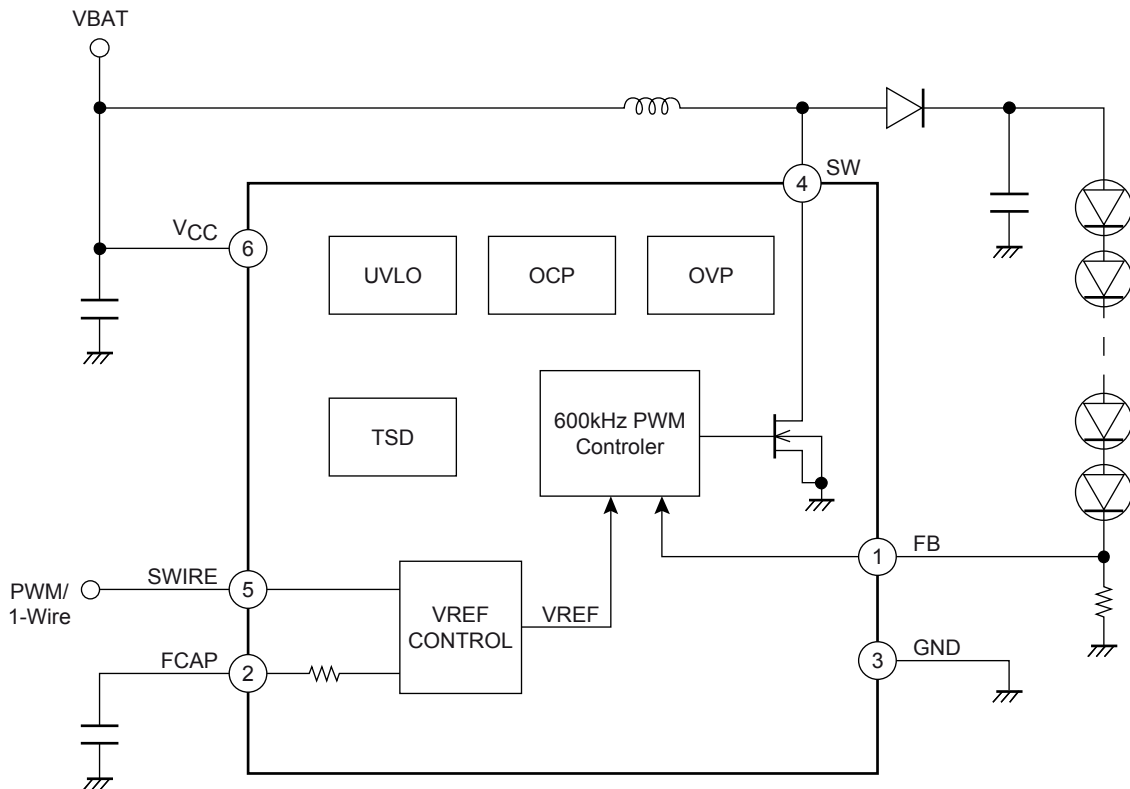

LV52204MU

Pin Connections

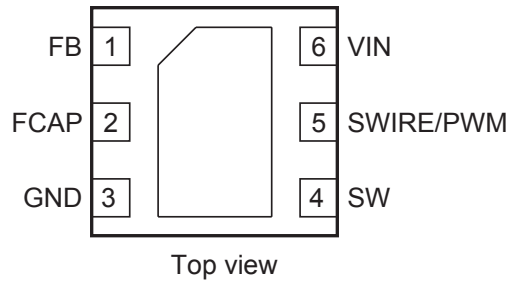

Pin Function

PIN #	Pin Name	Description
1	FB	Feedback pin.
2	FCAP	Filtering capacitor terminal for PWM mode.
3	GND	Ground
4	SW	Switch pin. Drain of the internal power FET.
5	SWIRE	1-wire dimming control and PWM dimming input (active High).
6	V _{CC}	Supply voltage.
	Expose-pad	Connect to GND on PCB.

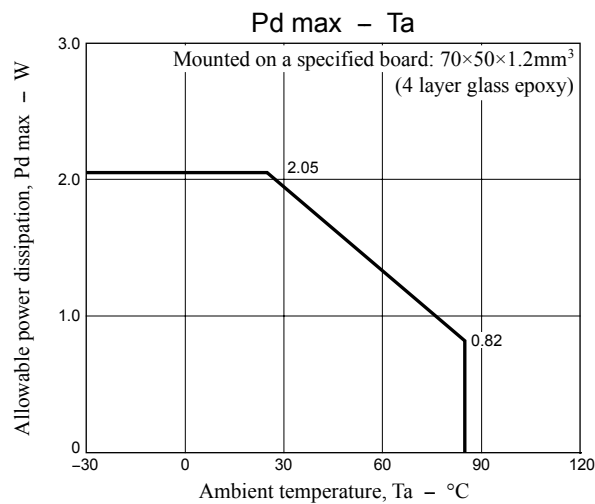

LED Current Setting

LED current is set by an external resistor connected between the FB pin and ground.

$$I_{LED} = V_{FB}/R_{FB}.$$

The V_{FB} can be controlled by two dimming modes, PWM Mode or Digital Mode. In PWM mode, PWM input is converted into a near DC current by the internal resistor R that was equivalent to $60k\Omega (\pm 10\%)$ and the external capacitor C_{FCAP} as a low pass filter with a cut-off frequency $f_c = 1/2\pi R_{FCAP}$. The V_{FB} can be adjusted by altering the duty cycle of the PWM signal (See Fig.1).

$$V_{FB} = 200 \text{ (mV)} \times \text{PWM Duty (\%)}$$

On the other hand, V_{FB} can be selected one from among 32 steps in Digital Mode (See Fig.2).

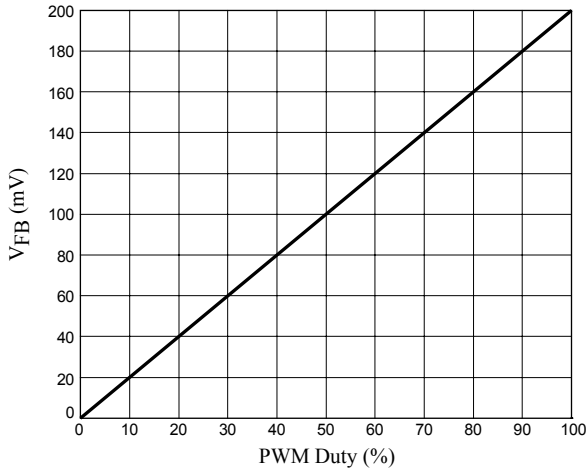

Fig1. V_{FB} vs. PWM Duty (PWM mode)

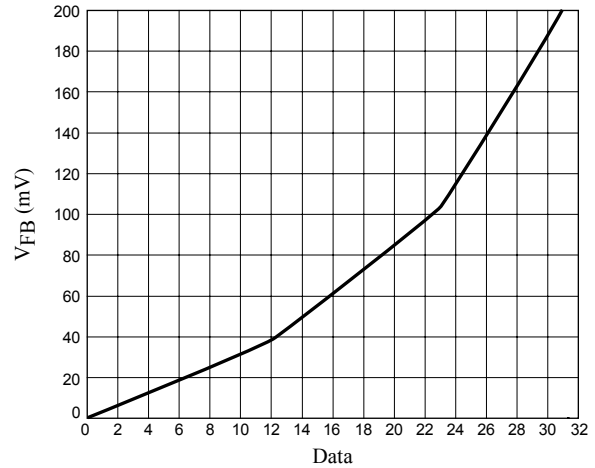

Fig2. V_{FB} vs. Data Register Value (Digital mode)

Dimming Mode Selection

Dimming Mode is selected by a specific pattern of the SWIRE within T_{sel} (1ms) from the startup of the device every time. In order to startup the device, the SWIRE must keep high for longer than T_{on} .

PWM Mode

The dimming mode is set to PWM mode when it is not recognized as a digital mode within T_{sel} . To enter Digital Mode, the SWIRE is required keeping in low state for T_{w1} (See Fig.4). If the PWM frequency is used faster than 6.6kHz, the dimming mode is set to PWM mode only. But slower than 6.6kHz, it is necessary to avoid entering the digital mode condition, such as SWIRE keeps high for longer than T_{sel} . PWM is enabled after T_{del} from T_{sel} .

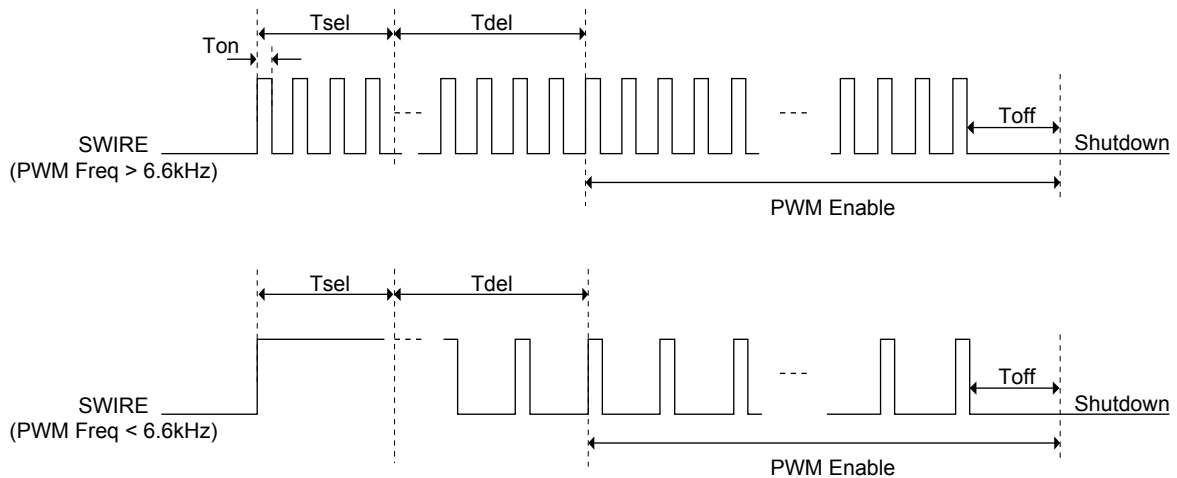

Fig3. SWIRE Timing Diagram in PWM mode

Digital Mode

To enter Digital Mode, SWIRE should be taken high for more than Tw0 (100µs) from the first rising edge and keep low state for Tw1(260µs) before Tsel(1ms).

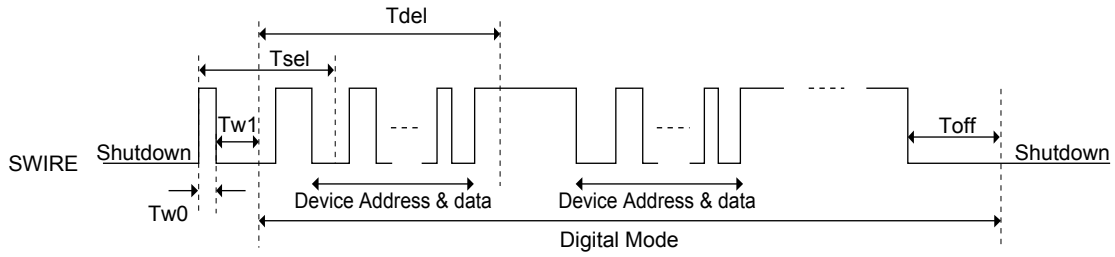

Fig4. SWIRE Timing Diagram in Digital mode

It is required sending the device address byte and the data byte to select VFB. The bit detection is determined by the ratio of Th and Tl (See Fig6). The start condition for the bit transmission required SWIRE high for at least Tstart. The end condition is required SWIRE low for at least Tend. When data is not being transferred, SWIRE is set in the “H” state. These registers are initialized with POR (Power On Reset).

In the LV52204MU, the device address (DA7 to DA0) is specified as “01110010”. D7 is setting for the acknowledge response. If the device address and the data byte are transferred on D7 = 1, the ACK signal is sent from the receive side to the send side. The acknowledge signal is issued when SWIRE on the send side is released and SWIRE on the receive side is set to low state. D6 and D5 need to send 0. D4 to D0 allow to changing the FB voltage.

	Register	BIT	Description
Device Address	DA7	7	0
	DA6	6	1
	DA5	5	1
	DA4	4	1
	DA3	3	0
	DA2	2	0
	DA1	1	1
	DA0	0	0

Table1. Device Address Description

	Register	BIT	Description
Data	D7	7	0 = Acknowledge disabled 1 = Acknowledge enabled
	D6	6	0
	D5	5	0
	D4	4	Data bit 4
	D3	3	Data bit 3
	D2	2	Data bit 2
	D1	1	Data bit 1
	D0	0	Data bit 0

Table2. Data Description

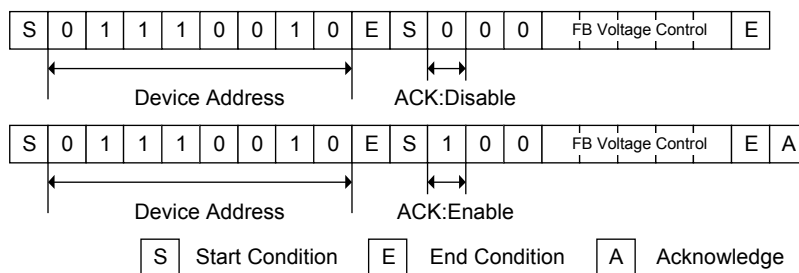

Fig5. Example of writing data

LV52204MU

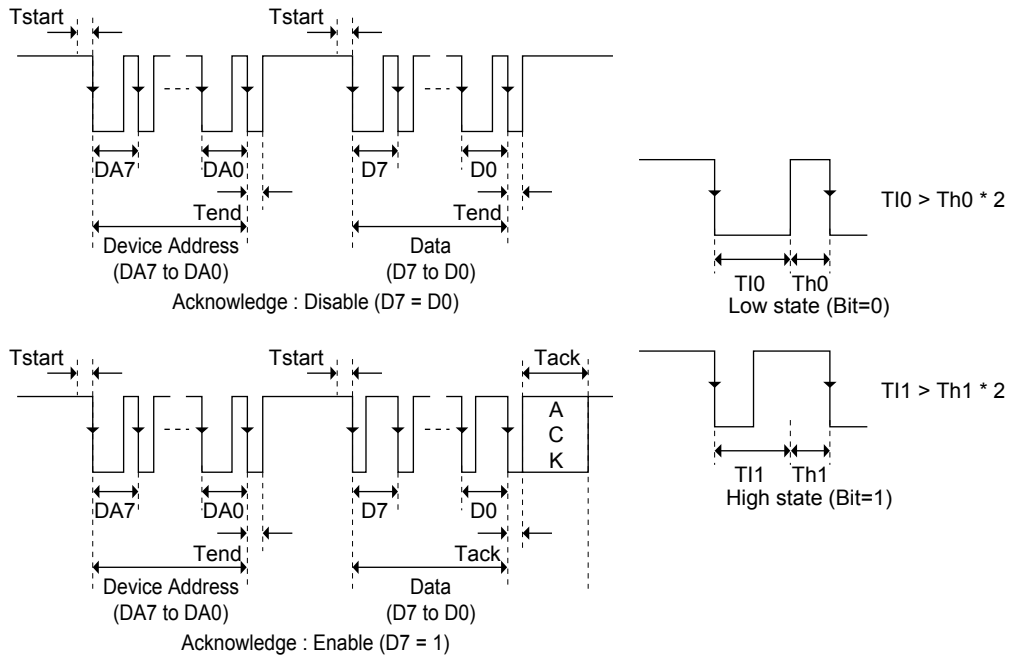

Fig6.Bit detection Diagram

	D7	D6	D5	D4	D3	D2	D1	D0	FB voltage (mV)
0	1/0	0	0	0	0	0	0	0	0
1	1/0	0	0	0	0	0	0	1	5
2	1/0	0	0	0	0	0	1	0	8
3	1/0	0	0	0	0	0	1	1	11
4	1/0	0	0	0	0	1	0	0	14
5	1/0	0	0	0	0	1	0	1	17
6	1/0	0	0	0	0	1	1	0	20
7	1/0	0	0	0	0	1	1	1	23
8	1/0	0	0	0	1	0	0	0	26
9	1/0	0	0	0	1	0	0	1	29
10	1/0	0	0	0	1	0	1	0	32
11	1/0	0	0	0	1	0	1	1	35
12	1/0	0	0	0	1	1	0	0	38
13	1/0	0	0	0	1	1	0	1	44
14	1/0	0	0	0	1	1	1	0	50
15	1/0	0	0	0	1	1	1	1	56
16	1/0	0	0	1	0	0	0	0	62
17	1/0	0	0	1	0	0	0	1	68
18	1/0	0	0	1	0	0	1	0	74
19	1/0	0	0	1	0	0	1	1	80
20	1/0	0	0	1	0	1	0	0	86
21	1/0	0	0	1	0	1	0	1	92
22	1/0	0	0	1	0	1	1	0	98
23	1/0	0	0	1	0	1	1	1	104
24	1/0	0	0	1	1	0	0	0	116
25	1/0	0	0	1	1	0	0	1	128
26	1/0	0	0	1	1	0	1	0	140
27	1/0	0	0	1	1	0	1	1	152
28	1/0	0	0	1	1	1	0	0	164
29	1/0	0	0	1	1	1	0	1	176
30	1/0	0	0	1	1	1	1	0	188
31	1/0	0	0	1	1	1	1	1	*200

(*Default)

Table3. Data Register vs. FB Voltage

Start up and Shutdown

The device becomes enabled when SWIRE is initially taken high. The dimming mode is determined within T_{sel} and the boost converter start up after T_{del} . To place the device into shutdown mode, the SWIRE must be held low for T_{off} .

PWM MODE

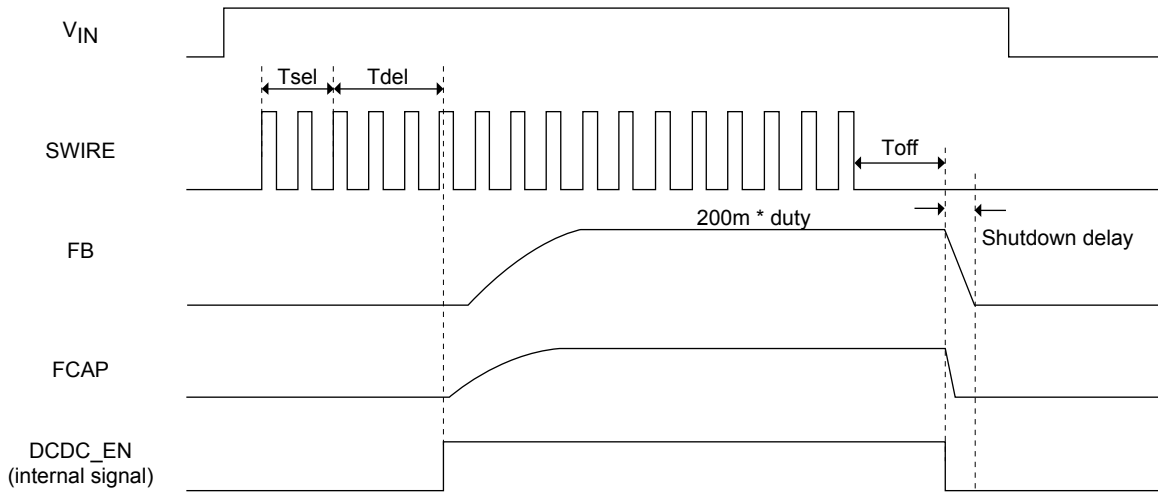

Digital MODE

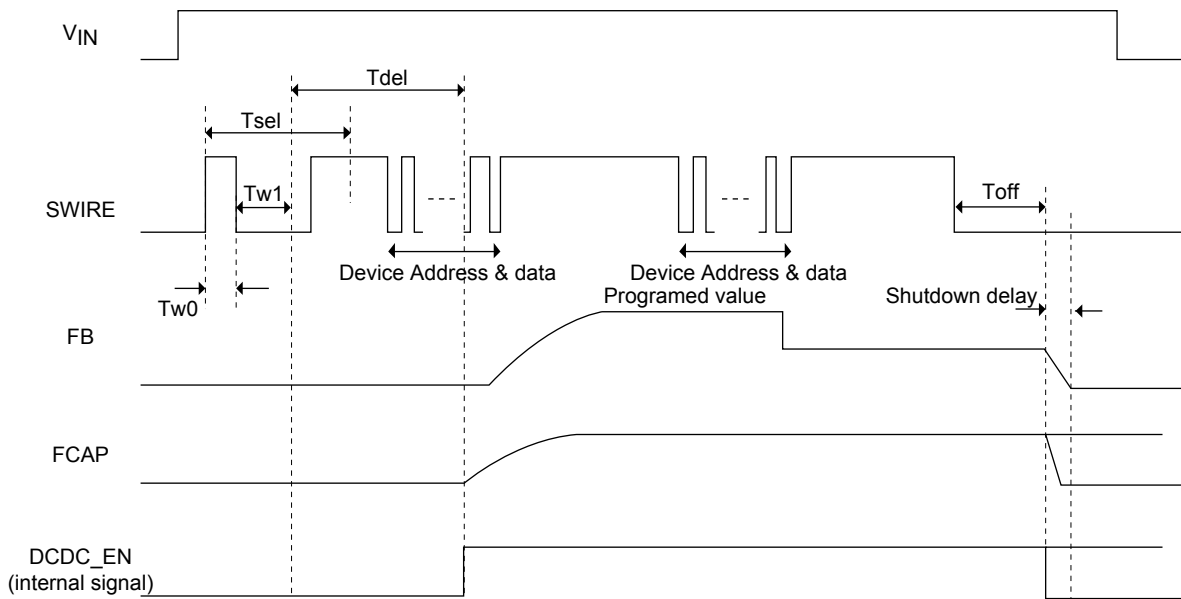

Fig7. Start up and shutdown diagram

LV52204MU

Open LED Protection

If SW terminal voltage exceeds a threshold V_{ovp} (38V typ) for 8 cycles, boost converter enters shutdown mode. In order to restart the IC, SWIRE signal is required again.

Over Current Protection

Current limit value for built-in power MOS is around 0.7A. The power MOS is turned off for each switching cycle when peak current through it exceeds the limit value.

Under Voltage Lock Out (UVLO)

UVLO operation works when V_{IN} terminal voltage is below 2.2V.

Thermal Shutdown

When chip temperature is too high, boost converter is stopped.

Application Circuit Diagram

10LEDs

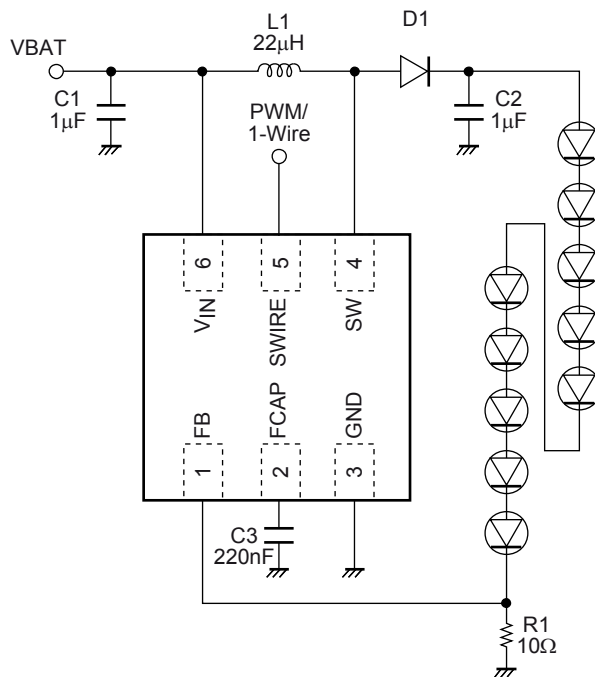

L1: VLS3012T-220M49 (TDK), VLF504015MT-220M (TDK)

D1: MBR0540T1 (ON semi), NSR05F40 (ONsemi)

C2: GRM21BR71H105K (Murata), C1608X5R1H105K (TDK)

LV52204MU

6LEDs

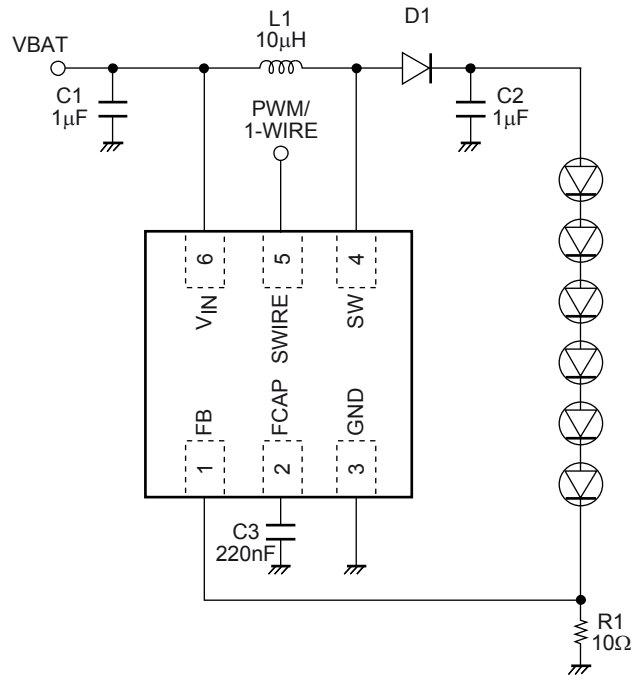

- L1: VLS3012T-100M72 (TDK), VLF302512M-100M (TDK)
D1: MBR0540T1 (ON semi), NSR05F40 (ONsemi)
C2: GRM21BR71H105K (Murata), C1608X5R1H105K (TDK)

LV52204MU

Typical Characteristics ($V_{IN} = 3.6V$, $L = 22\mu H$, $T = 25^\circ C$, unless otherwise specified)

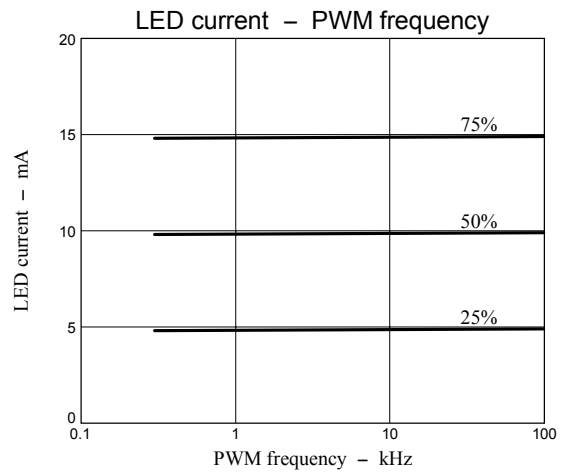
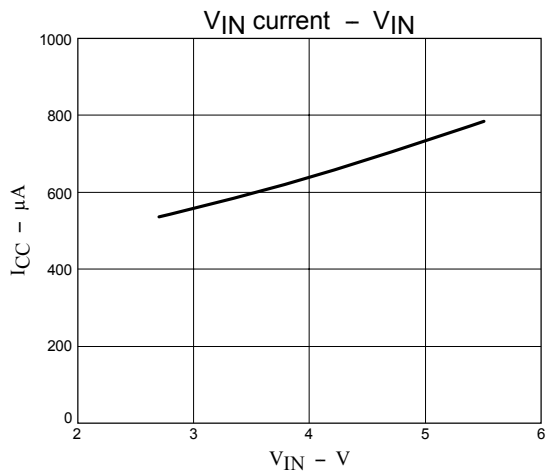
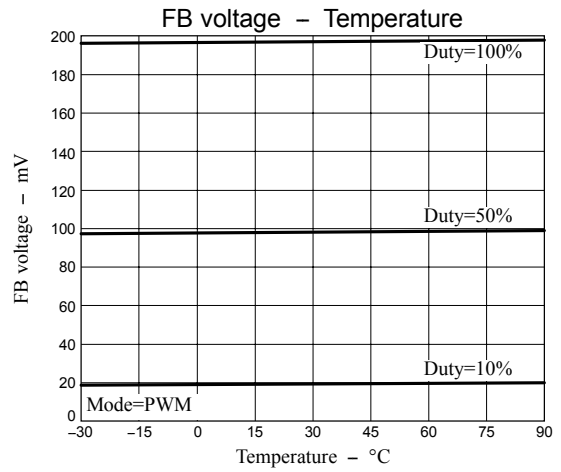
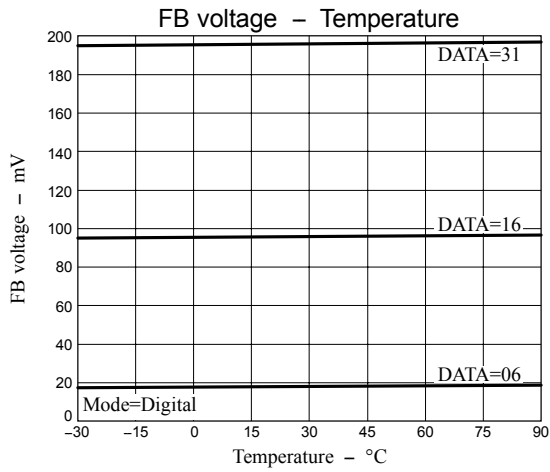
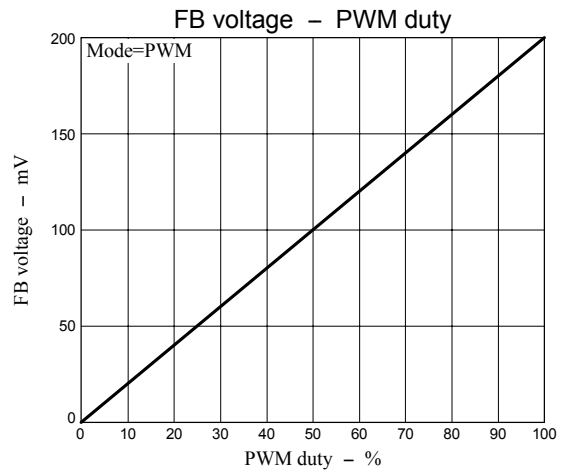
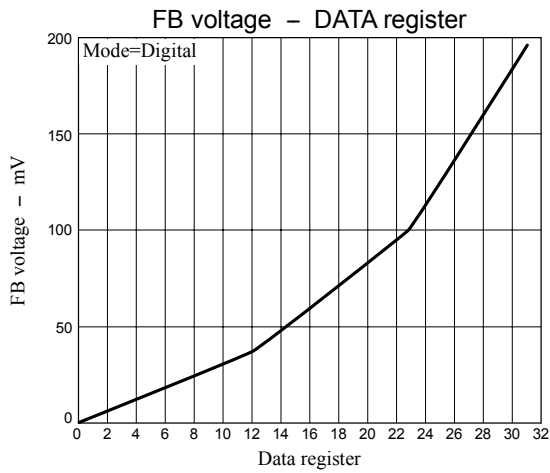
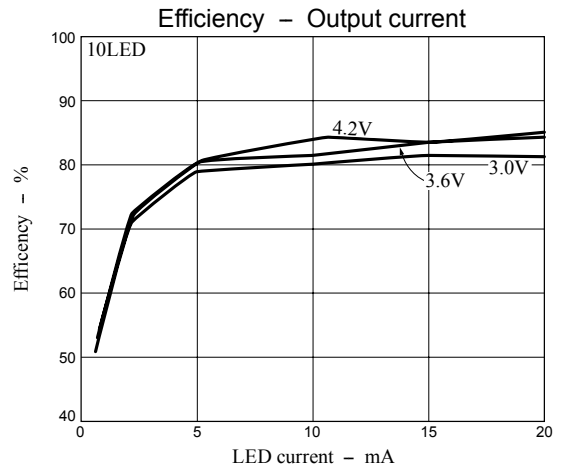
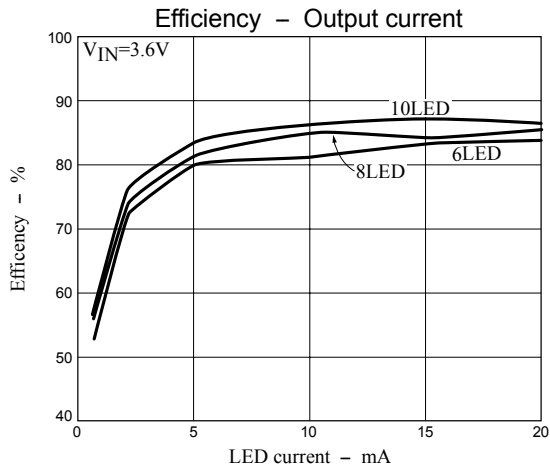

LV52204MU

PACKAGE DIMENSIONS

UDFN6 2x2, 0.65P
CASE 517AB
ISSUE C

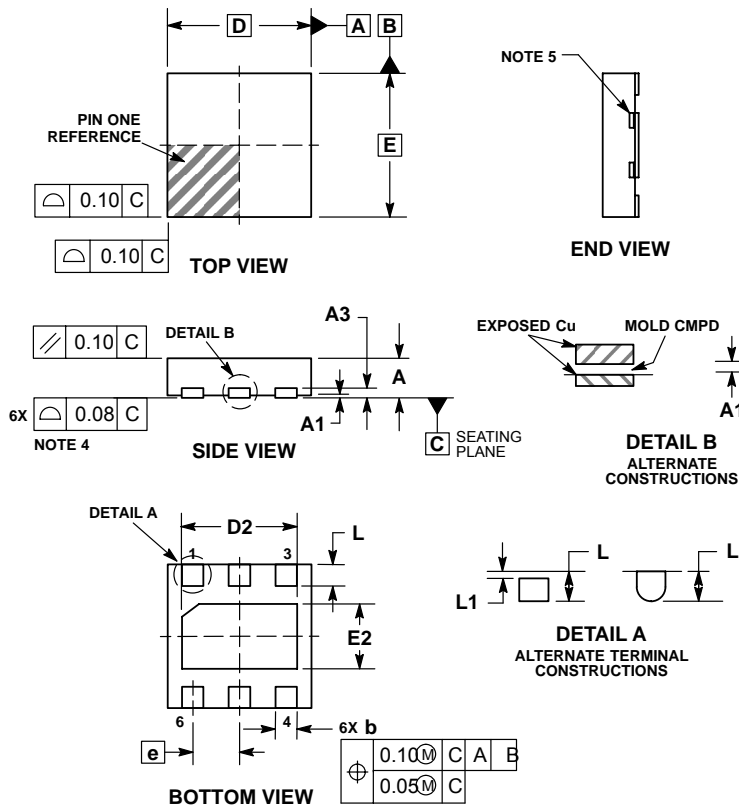

- NOTES:
1. DIMENSIONING AND TOLERANCING PER ASME Y14.5M, 1994.
 2. CONTROLLING DIMENSION: MILLIMETERS.
 3. DIMENSION b APPLIES TO PLATED TERMINAL AND IS MEASURED BETWEEN 0.15 AND 0.25MM FROM THE TERMINAL TIP.
 4. COPLANARITY APPLIES TO THE EXPOSED PAD AS WELL AS THE TERMINALS.
 5. TIE BARS MAY BE VISIBLE IN THIS VIEW AND ARE CONNECTED TO THE THERMAL PAD.

DIM	MILLIMETERS	
	MIN	MAX
A	0.45	0.55
A1	0.00	0.05
A3	0.127 REF	
b	0.25	0.35
D	2.00 BSC	
D2	1.50	1.70
E	2.00 BSC	
E2	0.80	1.00
e	0.65 BSC	
L	0.25	0.35
L1	---	0.15

GENERIC MARKING DIAGRAM*



- XX = Specific Device Code
- M = Date Code
- = Pb-Free Package

(Note: Microdot may be in either location)
 *This information is generic. Please refer to device data sheet for actual part marking. Pb-Free indicator, "G" or microdot "■", may or may not be present.

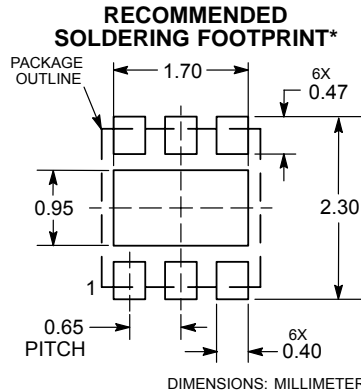

*For additional information on our Pb-Free strategy and soldering details, please download the ON Semiconductor Soldering and Mounting Techniques Reference Manual, SOLDERRM/D.

LV52204MU is as follows.

MARKING DIAGRAM

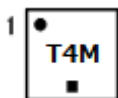

- T4 = Device Code
- M = Date Code
- = Pb-Free Package

UDFN6(2.0*2.0) 3,000 pcs/reel

1.EMBOSSED CARRIER TAPING

1 - 1 .Embossed carrier tape dimensions

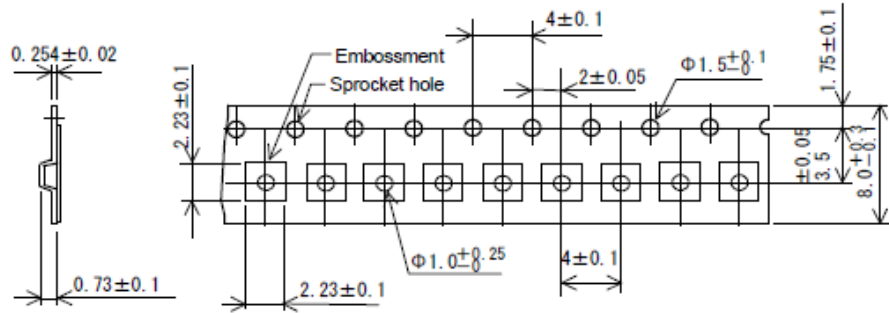

Unit Fmm

1 - 2 .Tape mounting direction

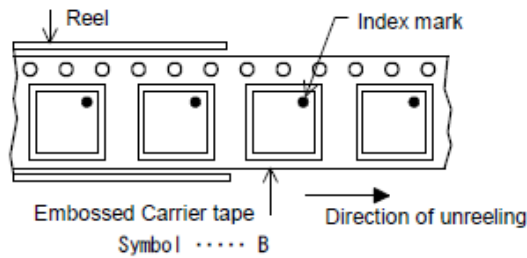

1 - 3 .Reel winding start and reel winding end

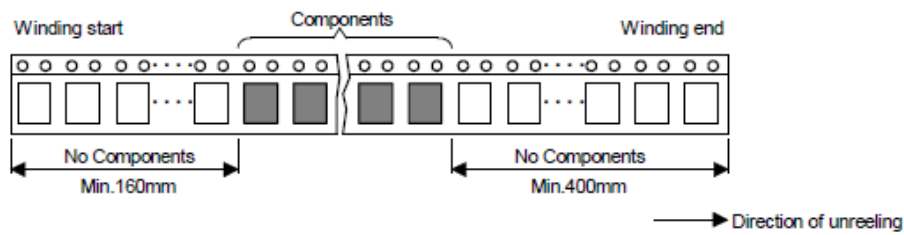

2 .TAPE STRENGTH

2 - 1 .Tensile strength of the carrier tape : Min.10N

2 - 2 .Peel strength of the top cover tape

(a)Peel angle : 165° to 180° relative to the tape adhesive surface

(b)Peel rate : 300mm / minute

(c)Peel of strength : 0.1N to 1.0N

3 .PARTS No. ON BAR CODE LABEL

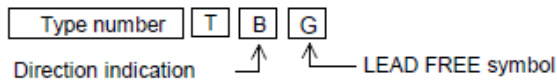

4 .REEL DIMENSIONS

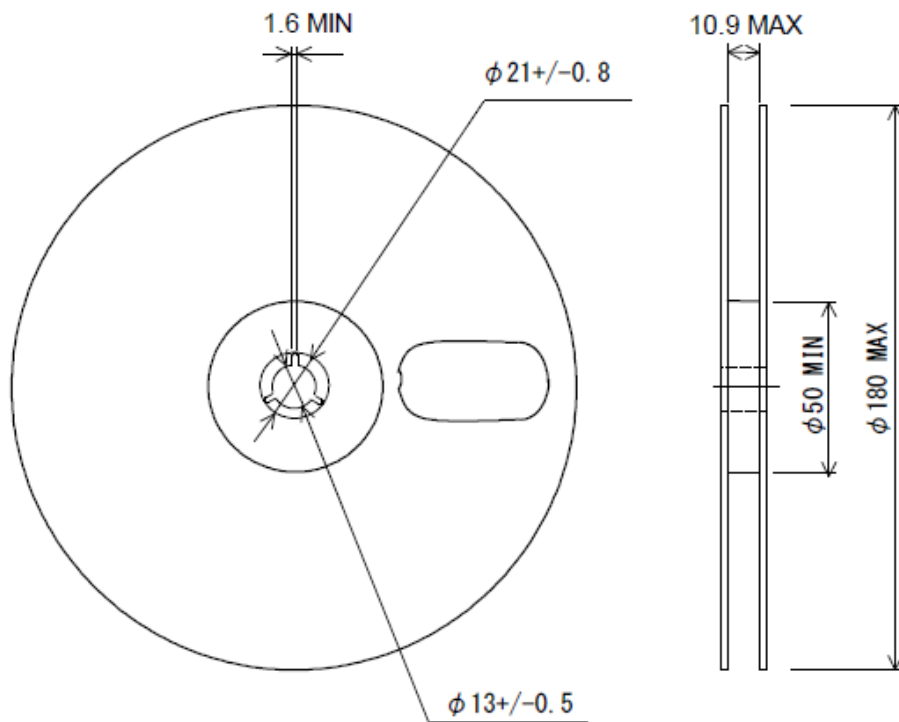

TYPE:P-RRM-08B
UNIT:mm

Packing Specification of Embossed Carrier Taping

UDFN6(2.0*2.0) 3,000 pcs/reel

Carrier tape type number	Package code	Maximum number of ICs contained (pcs.)		Packing form
		Reel	Inner box	Inner box. B50766P001
N22986D001	UDFN6(2.0*2.0)	3,000	30,000	10 Reels contained Dimensions:mm 190 × 136 × 186

MPN Label

(1P) MPN : * * * * *
 (1I) LOT : * * * * *
 (9D) DTE : * * * * *
 (Q) QTY : * * * * *
 CS: **
 ASSY IN: * * * * *

MS LEVEL: 1
 HOURS:UNLIMITED
 TEMP: 260C
 SEALED DATE: 19Jan12

(21L) ASSY LOC: **
 (S) SERIAL NBR: * * * * *

HF RoHS Pb 2LI e3 e ON

Packing Method

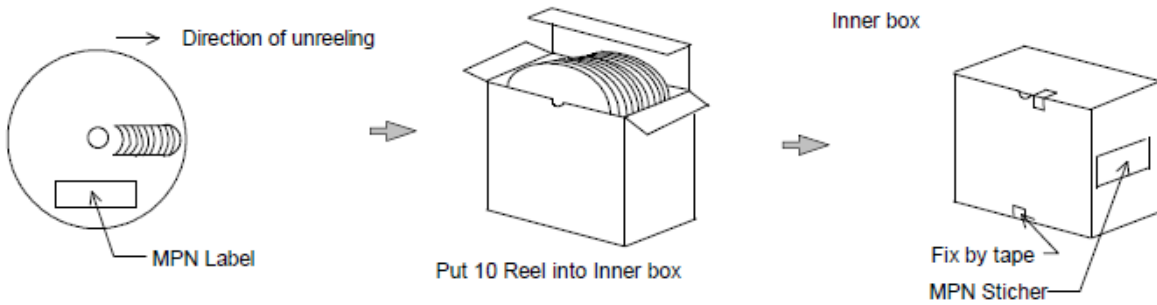

LV52204MU

ORDERING INFORMATION

Device	Package	Shipping (Qty / Packing)
LV52204MUTBG	UDFN6 (2x2) (Pb-Free)	3000 / Tape & Reel

ON Semiconductor and the ON logo are registered trademarks of Semiconductor Components Industries, LLC (SCILLC). SCILLC owns the rights to a number of patents, trademarks, copyrights, trade secrets, and other intellectual property. A listing of SCILLC's product/patent coverage may be accessed at www.onsemi.com/site/pdf/Patent-Marking.pdf. SCILLC reserves the right to make changes without further notice to any products herein. SCILLC makes no warranty, representation or guarantee regarding the suitability of its products for any particular purpose, nor does SCILLC assume any liability arising out of the application or use of any product or circuit, and specifically disclaims any and all liability, including without limitation special, consequential or incidental damages. "Typical" parameters which may be provided in SCILLC data sheets and/or specifications can and do vary in different applications and actual performance may vary over time. All operating parameters, including "Typicals" must be validated for each customer application by customer's technical experts. SCILLC does not convey any license under its patent rights nor the rights of others. SCILLC products are not designed, intended, or authorized for use as components in systems intended for surgical implant into the body, or other applications intended to support or sustain life, or for any other application in which the failure of the SCILLC product could create a situation where personal injury or death may occur. Should Buyer purchase or use SCILLC products for any such unintended or unauthorized application, Buyer shall indemnify and hold SCILLC and its officers, employees, subsidiaries, affiliates, and distributors harmless against all claims, costs, damages, and expenses, and reasonable attorney fees arising out of, directly or indirectly, any claim of personal injury or death associated with such unintended or unauthorized use, even if such claim alleges that SCILLC was negligent regarding the design or manufacture of the part. SCILLC is an Equal Opportunity/Affirmative Action Employer. This literature is subject to all applicable copyright laws and is not for resale in any manner.

Mouser Electronics

Authorized Distributor

Click to View Pricing, Inventory, Delivery & Lifecycle Information:

[ON Semiconductor:](#)

[LV52204MUGEVB](#)

Компания «Океан Электроники» предлагает заключение долгосрочных отношений при поставках импортных электронных компонентов на взаимовыгодных условиях!

Наши преимущества:

- Поставка оригинальных импортных электронных компонентов напрямую с производств Америки, Европы и Азии, а так же с крупнейших складов мира;
- Широкая линейка поставок активных и пассивных импортных электронных компонентов (более 30 млн. наименований);
- Поставка сложных, дефицитных, либо снятых с производства позиций;
- Оперативные сроки поставки под заказ (от 5 рабочих дней);
- Экспресс доставка в любую точку России;
- Помощь Конструкторского Отдела и консультации квалифицированных инженеров;
- Техническая поддержка проекта, помощь в подборе аналогов, поставка прототипов;
- Поставка электронных компонентов под контролем ВП;
- Система менеджмента качества сертифицирована по Международному стандарту ISO 9001;
- При необходимости вся продукция военного и аэрокосмического назначения проходит испытания и сертификацию в лаборатории (по согласованию с заказчиком);
- Поставка специализированных компонентов военного и аэрокосмического уровня качества (Xilinx, Altera, Analog Devices, Intersil, Interpoint, Microsemi, Actel, Aeroflex, Peregrine, VPT, Syfer, Eurofarad, Texas Instruments, MS Kennedy, Miteq, Cobham, E2V, MA-COM, Hittite, Mini-Circuits, General Dynamics и др.);

Компания «Океан Электроники» является официальным дистрибьютором и эксклюзивным представителем в России одного из крупнейших производителей разъемов военного и аэрокосмического назначения «JONHON», а так же официальным дистрибьютором и эксклюзивным представителем в России производителя высокотехнологичных и надежных решений для передачи СВЧ сигналов «FORSTAR».



JONHON

«JONHON» (основан в 1970 г.)

Разъемы специального, военного и аэрокосмического назначения:

(Применяются в военной, авиационной, аэрокосмической, морской, железнодорожной, горно- и нефтедобывающей отраслях промышленности)

«FORSTAR» (основан в 1998 г.)

ВЧ соединители, коаксиальные кабели, кабельные сборки и микроволновые компоненты:

(Применяются в телекоммуникациях гражданского и специального назначения, в средствах связи, РЛС, а так же военной, авиационной и аэрокосмической отраслях промышленности).



Телефон: 8 (812) 309-75-97 (многоканальный)

Факс: 8 (812) 320-03-32

Электронная почта: ocean@oceanchips.ru

Web: <http://oceanchips.ru/>

Адрес: 198099, г. Санкт-Петербург, ул. Калинина, д. 2, корп. 4, лит. А