

## FEATURES

- Precision 1:4, 400mV CML fanout buffer
- Low jitter performance:
  - 116fs<sub>RMS</sub> phase jitter (typ)
- Guaranteed AC performance over temperature/ voltage:
  - > 6GHz f<sub>MAX</sub> clock
  - < 60ps t<sub>r</sub> / t<sub>f</sub> times
  - < 250ps t<sub>pd</sub>
  - < 15ps max. skew
- Accepts an input signal as low as 100mV
- Unique input termination and V<sub>T</sub> pin accepts DC-coupled and AC-coupled differential inputs: LVPECL, LVDS, and CML
- 50ohms source terminated CML outputs
- Power supply 2.5V ±5% and 3.3V ±10%
- Industrial temperature range: -40°C to +85°C
- Available in 16-pin (3mm \* 3mm) QFN package



Precision Edge®

## DESCRIPTION

The SY58020U is a 2.5V/3.3V precision, high-speed, fully differential 1:4 CML fanout buffer. Optimized to provide four identical output copies with less than 15ps of skew and only 116fs<sub>RMS</sub> phase jitter, the SY58020U can process clock signals as fast as 6GHz.

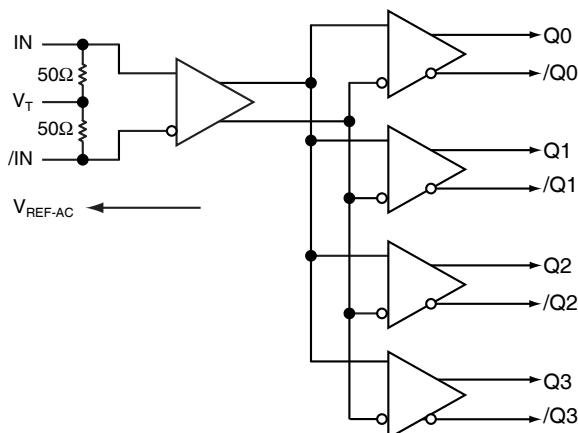
The differential input includes Micrel's unique, 3-pin input termination architecture interfaces to differential LVPECL, LVDS, and CML signals (AC- or DC-coupled) as small as 100mV without any level-shifting or termination resistor networks in the signal path. For AC-coupled input interface applications, an on-board output reference voltage (V<sub>REF-AC</sub>) is provided to bias the V<sub>T</sub> pin. The outputs are optimized to drive 400mV typical swing into 50ohms loads, with extremely fast rise/fall times guaranteed to be under 60ps.

The SY58020U operates from a 2.5V ±5% supply or 3.3V ±10% supply and is guaranteed over the full industrial temperature range (-40°C to +85°C). For applications that require LVPECL outputs, consider the SY58021U or SY58022U 1:4 fanout buffer with 800mV and 400mV output swing, respectively. The SY58020U is part of Micrel's high-speed, Precision Edge® product line. Data sheets and support documentation can be found on Micrel's web site at [www.micrel.com](http://www.micrel.com).

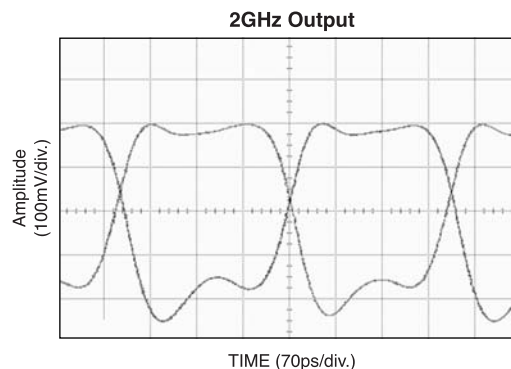
## APPLICATIONS

- All SONET and All GigE clock distribution
- Fibre Channel clock and data distribution
- Backplane distribution
- Data distribution: OC-48, OC-48+FEC, XAUI
- High-end, low skew, multiprocessor synchronous clock distribution

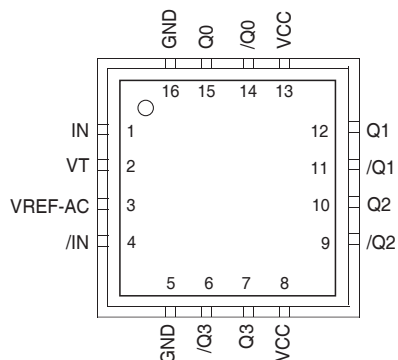
## FUNCTIONAL BLOCK DIAGRAM



## TYPICAL PERFORMANCE



**PACKAGE/ORDERING INFORMATION**



**16-Pin QFN (QFN-16)**

**Ordering Information<sup>(1)</sup>**

Part Number	Package Type	Operating Range	Package Marking
SY58020UMG	QFN-16 Pb-Free	Industrial	020U with Pb-Free bar-line indicator
SY58020UMGTR <sup>(2)</sup>	QFN-16 Pb-Free	Industrial	020U with Pb-Free bar-line indicator

**Notes:**

- Contact factory for die availability. Dice are guaranteed at  $T_A = 25^\circ\text{C}$ , DC electricals only. All devices are Pb-Free.
- Tape and Reel.

**PIN DESCRIPTION**

Pin Number	Pin Name	Pin Function
1, 4	IN, /IN	Differential Input: This input pair receives the signal to be buffered. Each pin of this pair internally terminates with 50ohms to the $V_T$ pin. Note that this input will default to an indeterminate state if left open. See “ <i>Input Interface Applications</i> ” section.
2	VT	Input Termination Center-Tap: Each input terminates to this pin. The $V_T$ pin provides a center-tap for each input (IN, /IN) to the termination network for maximum interface flexibility. See “ <i>Input Interface Applications</i> ” section.
3	VREF-AC	Reference Output Voltage: This output biases to $V_{CC} - 1.2\text{V}$ . It is used when AC-coupling to differential inputs. Connect $V_{REF-AC}$ directly to the $V_T$ pin. Bypass with $0.01\mu\text{F}$ low ESR capacitor to $V_{CC}$ . See “ <i>Input Interface Applications</i> ” section.
8, 13	VCC	Positive Power Supply: Bypass with $0.1\mu\text{F}/0.01\mu\text{F}$ low ESR capacitors as close to the pins as possible.
5, 16	GND, Exposed Pad	Ground. Exposed pad must be connected to a ground plane that is the same potential as the ground pin.
14, 15 11, 12 9, 10 6, 7	/Q0, Q0, /Q1, Q1, /Q2, Q2, /Q3, Q3,	CML Differential Output Pairs: Differential buffered output copy of the input signal. The output swing is typically 400mV into 50ohms load. Normally terminate CML output pairs with 100ohms across Q and /Q outputs at the receiving end. Unused output pairs may be left floating with no impact on jitter or skew. See “ <i>CML Output Termination</i> ” section.

### Absolute Maximum Ratings<sup>(Note 1)</sup>

Power Supply Voltage ( $V_{CC}$ )	.....	-0.5V to +4.0V
Input Voltage ( $V_{IN}$ )	.....	-0.5V to $V_{CC}$
CML Output Voltage ( $V_{OUT}$ )	.....	$V_{CC}-1.0V$ to $V_{CC}+0.5V$
Current ( $V_T$ )		
Source or sink current on $V_T$ pin	.....	$\pm 100mA$
Input Current		
Source or sink current on IN, /IN	.....	$\pm 50mA$
Current ( $V_{REF}$ )		
Source or sink current on $V_{REF-AC}$ , <b>Note 4</b>	.....	$\pm 1.5mA$
Lead Temperature Soldering, (20 seconds)	.....	260°C
Storage Temperature Range ( $T_{STORE}$ )	...	-65°C to +150°C

### Operating Ratings<sup>(Note 2)</sup>

Supply Voltage ( $V_{CC}$ )	.....	+2.375V to +3.60V
Operating Temperature Range ( $T_A$ )	.....	-40°C to +85°C
Package Thermal Resistance		
QFN ( $\theta_{JA}$ )		
Still-Air	.....	60°C/W
500lfpm	.....	54°C/W
QFN ( $\psi_{JB}$ )		
(Junction-to-Board Resistance), <b>Note 3</b>	.....	33°C/W

## DC ELECTRICAL CHARACTERISTICS<sup>(Notes 5)</sup>

$T_A = -40^\circ C$  to  $+85^\circ C$

Symbol	Parameter	Condition	Min	Typ	Max	Units
$V_{CC}$	Power Supply Voltage	$V_{CC} = 2.5V$	2.375	2.5	2.625	V
		$V_{CC} = 3.3V$	3.0	3.3	3.60	V
$I_{CC}$	Power Supply Current	No load, $V_{CC} = \text{max.}$ (includes internal 50ohms pull-up)		150	180	mA
$V_{IH}$	Input HIGH Voltage	<b>Note 6</b>	$V_{CC}-1.6$		$V_{CC}$	V
$V_{IL}$	Input LOW Voltage		0		$V_{IH}-0.1$	V
$V_{IN}$	Input Voltage Swing	See Figure 1a	0.1		1.7	V
$V_{DIFF\_IN}$	Differential Input Voltage Swing	See Figure 1b	0.2		3.4	V
$R_{IN}$	IN-to- $V_T$ Resistance		40	50	60	ohms
$V_{REF-AC}$	Output Reference Voltage		$V_{CC}-1.3$	$V_{CC}-1.2$	$V_{CC}-1.1$	V
$V_{TIN}$	IN-to- $V_T$ Voltage				1.28	V

## CML DC ELECTRICAL CHARACTERISTICS<sup>(Notes5)</sup>

$V_{CC} = 3.3V \pm 10\%$  or  $2.5V \pm 5\%$ ;  $R_L = 100\Omega$  across each output pair or equivalent;  $T_A = -40^\circ C$  to  $+85^\circ C$ , unless otherwise stated.

Symbol	Parameter	Condition	Min	Typ	Max	Units
$V_{OH}$	Output HIGH Voltage		$V_{CC}-0.020$	$V_{CC}-0.010$	$V_{CC}$	V
$V_{OUT}$	Output Voltage Swing	see Figure 1a	325	400	500	mV
$V_{DIFF\_OUT}$	Differential Output Voltage Swing	see Figure 1b	650	800	1000	mV
$R_{OUT}$	Output Source Impedance		40	50	60	ohms

- Note 1.** Permanent device damage may occur if ABSOLUTE MAXIMUM RATINGS are exceeded. This is a stress rating only and functional operation is not implied at conditions other than those detailed in the operational sections of this data sheet. Exposure to ABSOLUTE MAXIMUM RATINGS conditions for extended periods may affect device reliability.
- Note 2.** The data sheet limits are not guaranteed if the device is operated beyond the operating ratings.
- Note 3.** Thermal performance assumes exposed pad is soldered (or equivalent) to the device's most negative potential on the PCB.
- Note 4.** Due to the limited drive capability, use for input of the same package only.
- Note 5.** The circuit is designed to meet the DC specifications shown in the above table after thermal equilibrium has been established.
- Note 6.**  $V_{IH}$  (min.) not lower than 1.2V.

## AC ELECTIRCAL CHARACTERISTICS

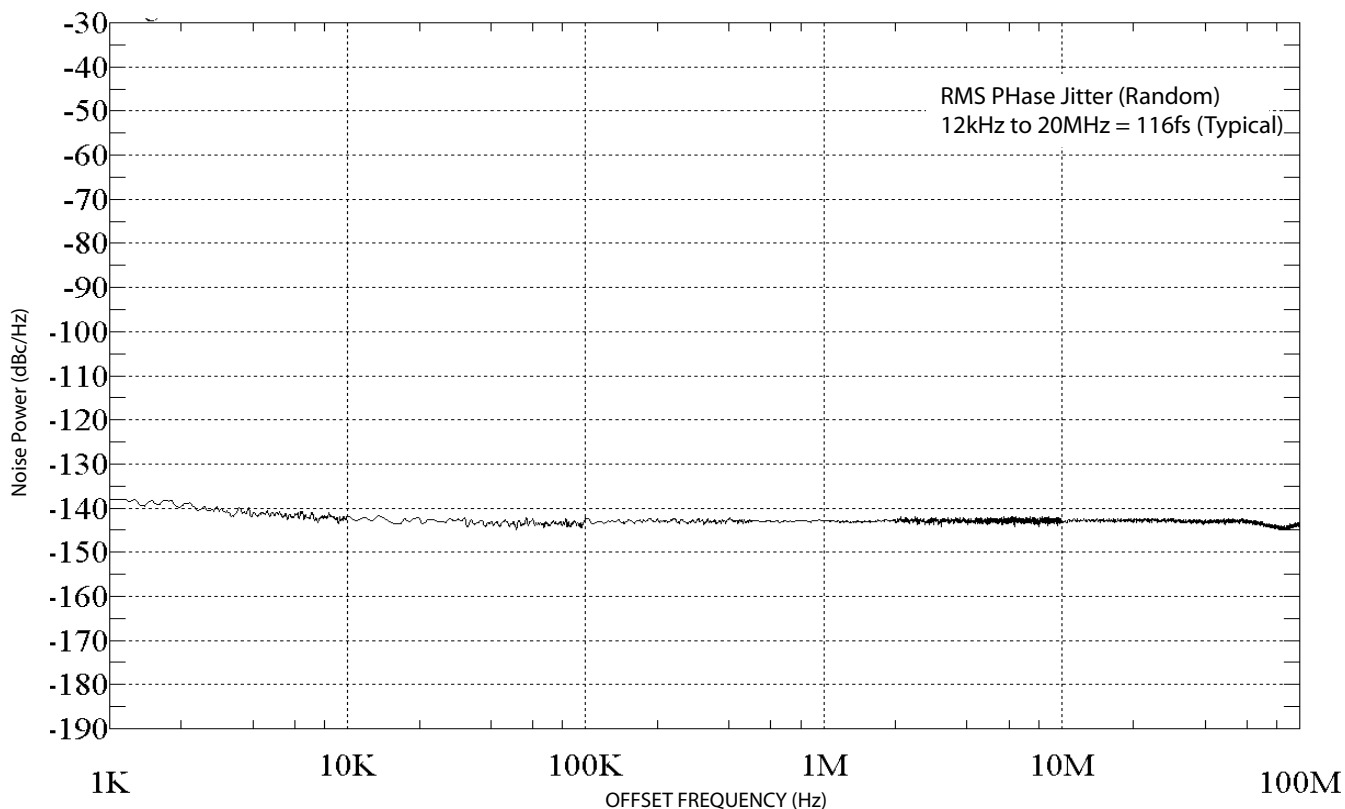
$V_{CC} = 2.5V \pm 5\%$  or  $3.3V \pm 10\%$ ;  $T_A = -40^{\circ}C$  to  $+85^{\circ}C$ ;  $R_L = 100ohms$  across each output pair or equivalent, unless otherwise stated.

Symbol	Parameter	Condition	Min	Typ	Max	Units
$f_{MAX}$	Maximum Operating Frequency	$V_{OUT} \cdot 200mV$ Clock	6			GHz
		NRZ Data		10		Gbps
$t_{pd}$	Propagation Delay		110	180	260	ps
$t_{CHAN}$	Channel-to-Channel Skew	<b>Note 7</b>		4	15	ps
$t_{SKEW}$	Part-to-Part Skew	<b>Note 8</b>			50	ps
$t_{JITTER}$	RMS Phase Jitter	Output = 622MHz Integration Range: 12kHz - 20MHz		116		fs(rms)
$t_r, t_f$	Output Rise/Fall Time 20% to 80%	At full swing	20	40	60	ps

**Note 7.** Skew is measured between outputs of the same bank under identical transitions.

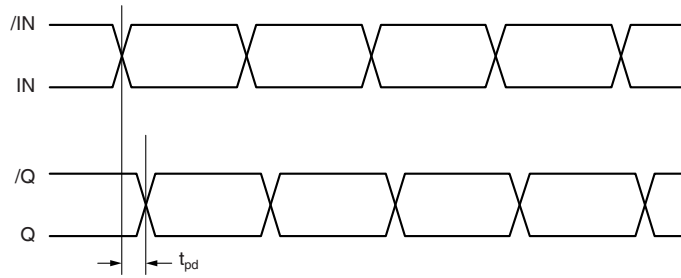
**Note 8.** Skew is defined for two parts with identical power supply voltages at the same temperature and with no skew of the edges at the respective inputs.

## PHASE NOISE



Phase Noise Plot: 622MHz @ 3.3V

**TIMING DIAGRAM**



**SINGLE-ENDED AND DIFFERENTIAL SWINGS**

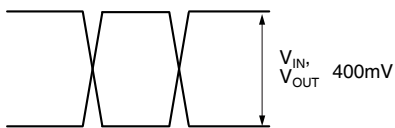


Figure 1a. Single-Ended Voltage Swing

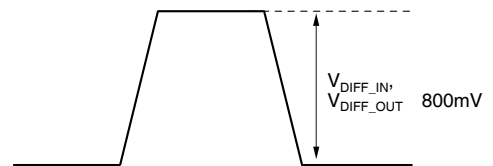
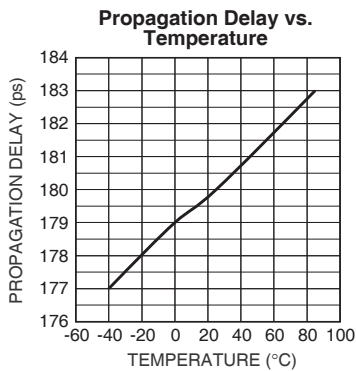
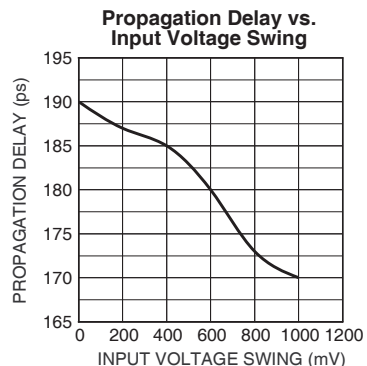
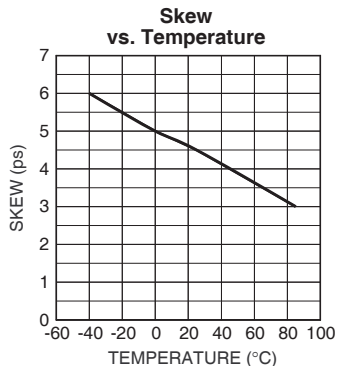
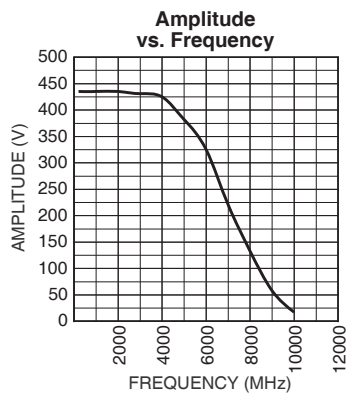


Figure 1b. Differential Voltage Swing

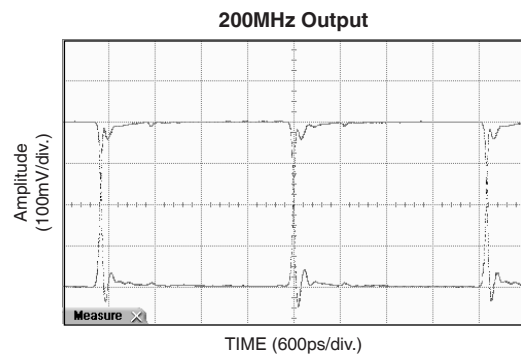
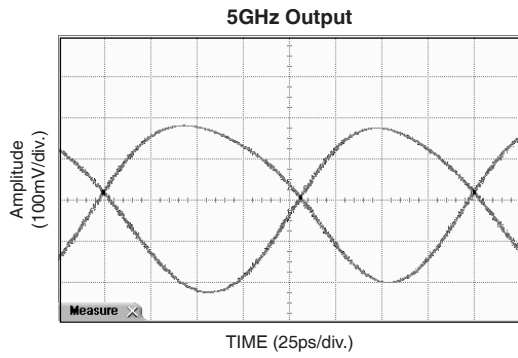
**TYPICAL OPERATING CHARACTERISTICS**

$V_{CC} = 2.5V$ ,  $GND = 0$ ,  $V_{IN} = 100mV$ ,  $T_A = 25^{\circ}C$ , unless otherwise stated.

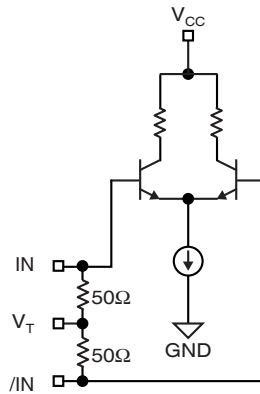


# FUNCTIONAL CHARACTERISTICS

$V_{CC} = 2.5V$ ,  $GND = 0$ ,  $V_{IN} = 100mV$ ,  $T_A = 25^{\circ}C$ , unless otherwise stated.

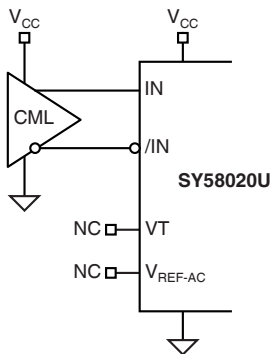


**INPUT STAGE**



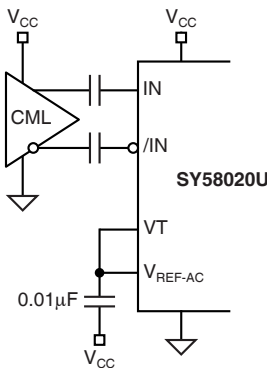
**Figure 2. Simplified Differential Input Buffer**

**INPUT INTERFACE APPLICATIONS**

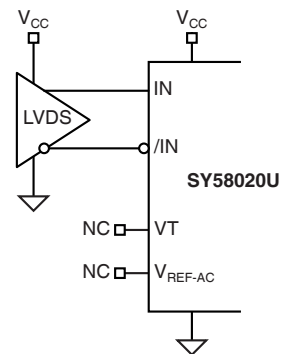


(Option: May connect  $V_T$  to  $V_{CC}$ )

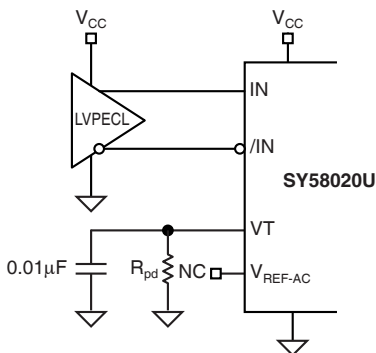
**Figure 3a. DC-Coupled CML Input Interface**



**Figure 3b. AC-Coupled CML Input Interface**

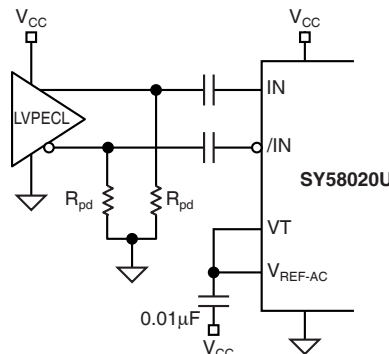


**Figure 3c. LVDS Input Interface**



For  $V_{CC} = 2.5V$ ,  $R_{pd} = 19\Omega$   
For  $V_{CC} = 3.3V$ ,  $R_{pd} = 50\Omega$

**Figure 3d. LVPECL Input Interface**



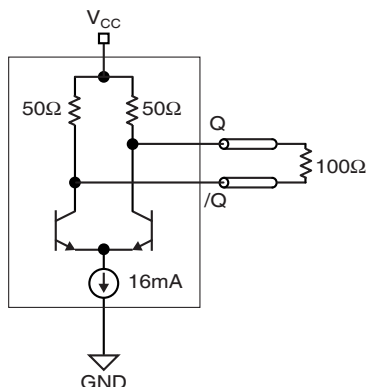
$R_{pd} = 100\Omega$  for a 3.3V system  
 $R_{pd} = 50\Omega$  for a 2.5V system

**Figure 3e. AC-Coupled LVPECL Input Interface**

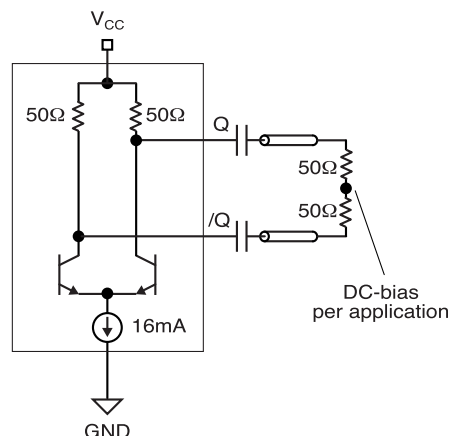


**CML OUTPUT TERMINATION**

Figures 4 and 5 illustrate how to terminate a CML output using both the AC-coupled and DC-coupled configuration. All outputs of the SY58020U are 50Ω with a 16mA current source.



**Figure 4. CML DC-Coupled**

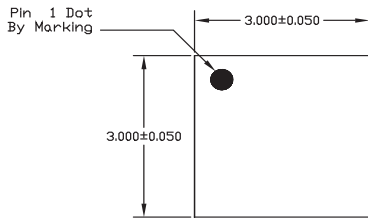


**Figure 5. CML AC-Coupled Termination**

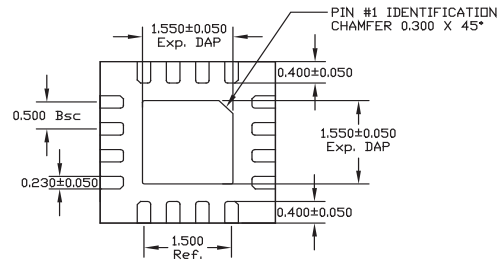
**RELATED MICREL PRODUCTS AND SUPPORT DOCUMENTATION**

Part Number	Function	Data Sheet Link
SY58020U	6GHz, 1:4 CML Fanout Buffer/Translator with Internal I/O Termination	<a href="http://www.micrel.com/product-info/products/sy58020u.shtml">http://www.micrel.com/product-info/products/sy58020u.shtml</a>
SY58021U	4GHz, 1:4 LVPECL Fanout Buffer/Translator with Internal Termination	<a href="http://www.micrel.com/product-info/products/sy58021u.shtml">http://www.micrel.com/product-info/products/sy58021u.shtml</a>
SY58022U	5.5GHz, 1:4 Fanout Buffer/Translator w/400mV LVPECL Outputs and Internal Input Termination	<a href="http://www.micrel.com/product-info/products/sy58022u.shtml">http://www.micrel.com/product-info/products/sy58022u.shtml</a>
	16-MLF™ Manufacturing Guidelines Exposed Pad Application Note	<a href="http://www.amkor.com/products/notes_papers/MLF_AppNote_0902.pdf">www.amkor.com/products/notes_papers/MLF_AppNote_0902.pdf</a>
M-0317	HBW Solutions	<a href="http://www.micrel.com/product-info/as/solutions.shtml">http://www.micrel.com/product-info/as/solutions.shtml</a>

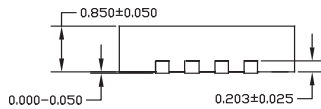
**16 LEAD QFN (QFN-16)**



TOP VIEW

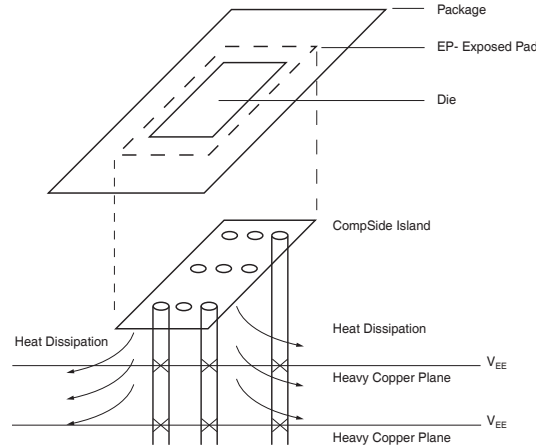


BOTTOM VIEW



SIDE VIEW

- NOTE:
1. ALL DIMENSIONS ARE IN MILLIMETERS.
  2. MAX. PACKAGE WARPAGE IS 0.05 mm.
  3. MAXIMUM ALLOWABLE BURRS IS 0.076 mm IN ALL DIRECTIONS.
  4. PIN #1 ID ON TOP WILL BE LASER/INK MARKED.



**PCB Thermal Consideration for 16-Pin QFN Package  
(Always solder, or equivalent, the exposed pad to the PCB)**

**Package Notes:**

- Note 1.** Package meets Level 2 qualification.
- Note 2.** All parts are dry-packaged before shipment.
- Note 3.** Exposed pads must be soldered to a ground for proper thermal management.

**MICREL, INC. 2180 FORTUNE DRIVE SAN JOSE, CA 95131 USA**  
TEL +1 (408) 944-0800 FAX +1 (408) 474-1000 WEB <http://www.micrel.com>

Micrel makes no representations or warranties with respect to the accuracy or completeness of the information furnished in this data sheet. This information is not intended as a warranty and Micrel does not assume responsibility for its use. Micrel reserves the right to change circuitry, specifications and descriptions at any time without notice. No license, whether express, implied, arising by estoppel or otherwise, to any intellectual property rights is granted by this document. Except as provided in Micrel's terms and conditions of sale for such products, Micrel assumes no liability whatsoever, and Micrel disclaims any express or implied warranty relating to the sale and/or use of Micrel products including liability or warranties relating to fitness for a particular purpose, merchantability, or infringement of any patent, copyright or other intellectual property right

Micrel Products are not designed or authorized for use as components in life support appliances, devices or systems where malfunction of a product can reasonably be expected to result in personal injury. Life support devices or systems are devices or systems that (a) are intended for surgical implant into the body or (b) support or sustain life, and whose failure to perform can be reasonably expected to result in a significant injury to the user. A Purchaser's use or sale of Micrel Products for use in life support appliances, devices or systems is a Purchaser's own risk and Purchaser agrees to fully indemnify Micrel for any damages resulting from such use or sale.

Компания «Океан Электроники» предлагает заключение долгосрочных отношений при поставках импортных электронных компонентов на взаимовыгодных условиях!

Наши преимущества:

- Поставка оригинальных импортных электронных компонентов напрямую с производств Америки, Европы и Азии, а так же с крупнейших складов мира;
- Широкая линейка поставок активных и пассивных импортных электронных компонентов (более 30 млн. наименований);
- Поставка сложных, дефицитных, либо снятых с производства позиций;
- Оперативные сроки поставки под заказ (от 5 рабочих дней);
- Экспресс доставка в любую точку России;
- Помощь Конструкторского Отдела и консультации квалифицированных инженеров;
- Техническая поддержка проекта, помощь в подборе аналогов, поставка прототипов;
- Поставка электронных компонентов под контролем ВП;
- Система менеджмента качества сертифицирована по Международному стандарту ISO 9001;
- При необходимости вся продукция военного и аэрокосмического назначения проходит испытания и сертификацию в лаборатории (по согласованию с заказчиком);
- Поставка специализированных компонентов военного и аэрокосмического уровня качества (Xilinx, Altera, Analog Devices, Intersil, Interpoint, Microsemi, Actel, Aeroflex, Peregrine, VPT, Syfer, Eurofarad, Texas Instruments, MS Kennedy, Miteq, Cobham, E2V, MA-COM, Hittite, Mini-Circuits, General Dynamics и др.);

Компания «Океан Электроники» является официальным дистрибьютором и эксклюзивным представителем в России одного из крупнейших производителей разъемов военного и аэрокосмического назначения «JONHON», а так же официальным дистрибьютором и эксклюзивным представителем в России производителя высокотехнологичных и надежных решений для передачи СВЧ сигналов «FORSTAR».



## JONHON

«JONHON» (основан в 1970 г.)

Разъемы специального, военного и аэрокосмического назначения:

(Применяются в военной, авиационной, аэрокосмической, морской, железнодорожной, горно- и нефтедобывающей отраслях промышленности)

«FORSTAR» (основан в 1998 г.)

ВЧ соединители, коаксиальные кабели,  
кабельные сборки и микроволновые компоненты:

(Применяются в телекоммуникациях гражданского и специального назначения, в средствах связи, РЛС, а так же военной, авиационной и аэрокосмической отраслях промышленности).



Телефон: 8 (812) 309-75-97 (многоканальный)

Факс: 8 (812) 320-03-32

Электронная почта: [ocean@oceanchips.ru](mailto:ocean@oceanchips.ru)

Web: <http://oceanchips.ru/>

Адрес: 198099, г. Санкт-Петербург, ул. Калинина, д. 2, корп. 4, лит. А