

EVALUATION KIT  
AVAILABLE

# MAXIM

## Dual, 256-Tap, Nonvolatile, I<sup>2</sup>C-Interface, Digital Potentiometers

### General Description

The MAX5477/MAX5478/MAX5479 nonvolatile, dual, linear-taper, digital potentiometers perform the function of a mechanical potentiometer, but replace the mechanics with a simple 2-wire digital interface. Each device performs the same function as a discrete potentiometer or variable resistor and has 256 tap points.

The devices feature an internal, nonvolatile EEPROM used to store the wiper position for initialization during power-up. A write-protect feature prevents accidental overwrites of the EEPROM. The fast-mode I<sup>2</sup>C-compatible serial interface allows communication at data rates up to 400kbps, minimizing board space and reducing interconnection complexity in many applications. Three address inputs allow a total of eight unique address combinations.

The MAX5477/MAX5478/MAX5479 provide three nominal resistance values: 10k $\Omega$  (MAX5477), 50k $\Omega$  (MAX5478), or 100k $\Omega$  (MAX5479). The nominal resistor temperature coefficient is 70ppm/ $^{\circ}$ C end-to-end and 10ppm/ $^{\circ}$ C ratiometric. The low temperature coefficient makes the devices ideal for applications requiring a low-temperature-coefficient variable resistor, such as low-drift, programmable gain-amplifier circuit configurations.

The MAX5477/MAX5478/MAX5479 are available in 16-pin 3mm x 3mm x 0.8mm TQFN and 14-pin 4.4mm x 5mm TSSOP packages. These devices operate over the extended -40 $^{\circ}$ C to +85 $^{\circ}$ C temperature range.

### Applications

Mechanical Potentiometer Replacement  
Low-Drift Programmable-Gain Amplifiers  
Volume Control  
Liquid-Crystal Display (LCD) Contrast Control

### Features

- ◆ Power-On Recall of Wiper Position from Nonvolatile Memory
- ◆ EEPROM Write Protection
- ◆ Tiny 3mm x 3mm x 0.8mm Thin QFN Package
- ◆ 70ppm/ $^{\circ}$ C End-to-End Resistance Temperature Coefficient
- ◆ 10ppm/ $^{\circ}$ C Ratiometric Temperature Coefficient
- ◆ Fast 400kbps I<sup>2</sup>C-Compatible Serial Interface
- ◆ 1 $\mu$ A (max) Static Supply Current
- ◆ Single-Supply Operation: +2.7V to +5.25V
- ◆ 256 Tap Positions per Potentiometer
- ◆  $\pm 0.5$  LSB DNL in Voltage-Divider Mode
- ◆  $\pm 1$  LSB INL in Voltage-Divider Mode

### Functional Diagram

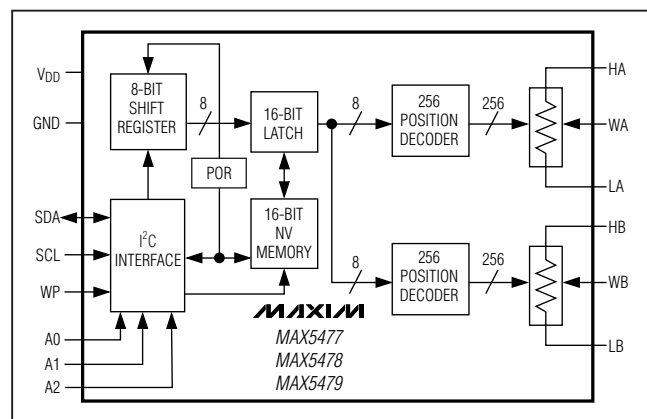

Pin Configurations appear at end of data sheet.

### Ordering Information/Selector Guide

PART	TEMP RANGE	PIN-PACKAGE	END-TO-END RESISTANCE (k $\Omega$ )	TOP MARK
MAX5477ETE+T	-40 $^{\circ}$ C to +85 $^{\circ}$ C	16 TQFN-EP*	10	ABO
MAX5477EUD+	-40 $^{\circ}$ C to +85 $^{\circ}$ C	14 TSSOP	10	—
MAX5478ETE+T	-40 $^{\circ}$ C to +85 $^{\circ}$ C	16 TQFN-EP*	50	ABP
MAX5478EUD+	-40 $^{\circ}$ C to +85 $^{\circ}$ C	14 TSSOP	50	—
MAX5479ETE+T	-40 $^{\circ}$ C to +85 $^{\circ}$ C	16 TQFN-EP*	100	ABQ
MAX5479EUD+	-40 $^{\circ}$ C to +85 $^{\circ}$ C	14 TSSOP	100	—

+ Denotes a lead(Pb)-free/RoHS-compliant package.

T = Tape and reel.

\*EP = Exposed pad.

MAXIM

Maxim Integrated Products 1

For pricing, delivery, and ordering information, please contact Maxim/Dallas Direct! at 1-888-629-4642, or visit Maxim's website at [www.maxim-ic.com](http://www.maxim-ic.com).

MAX5477/MAX5478/MAX5479

# Dual, 256-Tap, Nonvolatile, I<sup>2</sup>C-Interface, Digital Potentiometers

## ABSOLUTE MAXIMUM RATINGS

SDA, SCL, V <sub>DD</sub> to GND	-0.3V to +6.0V
All Other Pins to GND	-0.3V to (V <sub>DD</sub> + 0.3V)
Maximum Continuous Current into H <sub>-</sub> , L <sub>-</sub> , and W <sub>-</sub>	
MAX5477	±5.0mA
MAX5478	±1.3mA
MAX5479	±0.6mA
Continuous Power Dissipation (T <sub>A</sub> = +70°C)	
16-Pin TQFN (derate 17.5mW/°C above +70°C)	1398mW
14-Pin TSSOP (derate 9.1mW/°C above +70°C)	727mW

Operating Temperature Range	-40°C to +85°C
Maximum Junction Temperature	+150°C
Storage Temperature Range	-65°C to +150°C
Lead Temperature (soldering, 10s)	+300°C
Soldering Temperature (reflow)	+260°C

Stresses beyond those listed under "Absolute Maximum Ratings" may cause permanent damage to the device. These are stress ratings only, and functional operation of the device at these or any other conditions beyond those indicated in the operational sections of the specifications is not implied. Exposure to absolute maximum rating conditions for extended periods may affect device reliability.

## PACKAGE THERMAL CHARACTERISTICS (Note 1)

TQFN	TSSOP		
Junction-to-Ambient Thermal Resistance (θ <sub>JA</sub> )	.....57.2°C/W	Junction-to-Ambient Thermal Resistance (θ <sub>JA</sub> )	.....100.4°C/W
Junction-to-Case Thermal Resistance (θ <sub>JC</sub> )	.....40°C/W	Junction-to-Case Thermal Resistance (θ <sub>JC</sub> )	.....30°C/W

**Note 1:** Package thermal resistances were obtained using the method described in JEDEC specification JESD51-7, using a four-layer board. For detailed information on package thermal considerations, refer to [www.maxim-ic.com/thermal-tutorial](http://www.maxim-ic.com/thermal-tutorial).

## ELECTRICAL CHARACTERISTICS

(V<sub>DD</sub> = +2.7V to +5.25V, H<sub>-</sub> = V<sub>DD</sub>, L<sub>-</sub> = GND, T<sub>A</sub> = -40°C to +85°C, unless otherwise noted. Typical values are at V<sub>DD</sub> = +5V, T<sub>A</sub> = +25°C.) (Note 2)

PARAMETER	SYMBOL	CONDITIONS	MIN	TYP	MAX	UNITS
<b>DC PERFORMANCE (VOLTAGE-DIVIDER MODE)</b>						
Resolution			256			Taps
Integral Nonlinearity	INL	(Note 3)			±1	LSB
Differential Nonlinearity	DNL	(Note 3)			±0.5	LSB
Dual Code Matching		R0 and R1 set to same code (all codes)			±1	LSB
End-to-End Resistance Temperature Coefficient	TC <sub>R</sub>			70		ppm/°C
Ratiometric Resistance Temperature Coefficient				10		ppm/°C
Full-Scale Error		MAX5477		-4		LSB
		MAX5478		-0.6		
		MAX5479		-0.3		
Zero-Scale Error		MAX5477		4		LSB
		MAX5478		0.6		
		MAX5479		0.3		
<b>DC PERFORMANCE (VARIABLE-RESISTOR MODE)</b>						
Integral Nonlinearity (Note 4)	INL	V <sub>DD</sub> = 3V			±3	LSB
		V <sub>DD</sub> = 5V			±1.5	
Differential Nonlinearity (Note 4)	DNL	MAX5477		±1		LSB
		MAX5478			±1	
		MAX5479			±1	

# Dual, 256-Tap, Nonvolatile, I<sup>2</sup>C-Interface, Digital Potentiometers

MAX5477/MAX5478/MAX5479

## ELECTRICAL CHARACTERISTICS (continued)

(V<sub>DD</sub> = +2.7V to +5.25V, H<sub>-</sub> = V<sub>DD</sub>, L<sub>-</sub> = GND, T<sub>A</sub> = -40°C to +85°C, unless otherwise noted. Typical values are at V<sub>DD</sub> = +5V, T<sub>A</sub> = +25°C.) (Note 2)

PARAMETER	SYMBOL	CONDITIONS	MIN	TYP	MAX	UNITS
Dual Code Matching		R0 and R1 set to same code (all codes), V <sub>DD</sub> = 3V or 5V			±3	LSB
<b>DC PERFORMANCE (RESISTOR CHARACTERISTICS)</b>						
Wiper Resistance	R <sub>W</sub>	(Note 5)		325	675	Ω
Wiper Capacitance	C <sub>W</sub>			10		pF
End-to-End Resistance	R <sub>HL</sub>	MAX5477	7.5	10	12.5	kΩ
		MAX5478	37.5	50	62.5	
		MAX5479	75	100	125	
<b>DIGITAL INPUTS</b>						
Input High Voltage (Note 6)	V <sub>IH</sub>	V <sub>DD</sub> = 3.4V to 5.25V	2.4			V
		V <sub>DD</sub> < 3.4V	0.7 × V <sub>DD</sub>			
Input Low Voltage	V <sub>IL</sub>	(Note 6)			0.8	V
Output Low Voltage	V <sub>OL</sub>	I <sub>SINK</sub> = 3mA			0.4	V
WP Pullup Resistance	I <sub>WP</sub>		255			kΩ
Input Leakage Current	I <sub>LEAK</sub>				±1	μA
Input Capacitance				5		pF
<b>DYNAMIC CHARACTERISTICS</b>						
Crosstalk		H <sub>A</sub> = 1kHz (0 to V <sub>DD</sub> ), L <sub>A</sub> = GND, L <sub>B</sub> = GND, measure W <sub>B</sub>		-75		dB
3dB Bandwidth (Note 7)		MAX5477		400		kHz
		MAX5478		100		
		MAX5479		50		
Total Harmonic Distortion Plus Noise	THD+N	H <sub>-</sub> = 1V <sub>RMS</sub> , f = 1kHz, L <sub>-</sub> = GND, measure W <sub>-</sub>		0.003		%
<b>NONVOLATILE MEMORY RELIABILITY</b>						
Data Retention		T <sub>A</sub> = +85°C		50		Years
Endurance		T <sub>A</sub> = +25°C		200,000		Stores
		T <sub>A</sub> = +85°C		50,000		
<b>POWER SUPPLY</b>						
Power-Supply Voltage	V <sub>DD</sub>		2.70		5.25	V
Supply Current	I <sub>DD</sub>	Writing to EEPROM, digital inputs at GND or V <sub>DD</sub> , T <sub>A</sub> = +25°C (Note 8)		250	400	μA
		Normal operation, digital inputs at GND or V <sub>DD</sub> , T <sub>A</sub> = +25°C	WP = GND	15	20.6	
			WP = V <sub>DD</sub>	0.5	1	

# Dual, 256-Tap, Nonvolatile, I<sup>2</sup>C-Interface, Digital Potentiometers

## TIMING CHARACTERISTICS

(V<sub>DD</sub> = +2.7V to +5.25V, H<sub>-</sub> = V<sub>DD</sub>, L<sub>-</sub> = GND, T<sub>A</sub> = -40°C to +85°C, unless otherwise noted. Typical values are at V<sub>DD</sub> = +5V, T<sub>A</sub> = +25°C. See Figure 1.) (Notes 9 and 10)

PARAMETER	SYMBOL	CONDITIONS	MIN	TYP	MAX	UNITS
<b>ANALOG SECTION</b>						
Wiper Settling Time (Note 11)	t <sub>WS</sub>	MAX5477		325		ns
		MAX5478		500		
		MAX5479		1000		
<b>DIGITAL SECTION</b>						
SCL Clock Frequency	f <sub>SCL</sub>				400	kHz
Setup Time for START Condition	t <sub>SU:STA</sub>		0.6			μs
Hold Time for START Condition	t <sub>HD:STA</sub>		0.6			μs
SCL High Time	t <sub>HIGH</sub>		0.6			μs
SCL Low Time	t <sub>LOW</sub>		1.3			μs
Data Setup Time	t <sub>SU:DAT</sub>		100			ns
Data Hold Time	t <sub>HD:DAT</sub>		0		0.9	μs
SDA, SCL Rise Time	t <sub>R</sub>				300	ns
SDA, SCL Fall Time	t <sub>F</sub>				300	ns
Setup Time for STOP Condition	t <sub>SU:STO</sub>		0.6			μs
Bus Free Time Between STOP and START Condition	t <sub>BUF</sub>	Minimum power-up rate = 0.2V/μs	1.3			μs
Pulse Width of Spike Suppressed	t <sub>SP</sub>				50	ns
Capacitive Load for Each Bus Line	C <sub>B</sub>	(Note 12)			400	pF
Write NV Register Busy Time		(Note 13)			12	ms

**Note 2:** All devices are production tested at T<sub>A</sub> = +25°C and are guaranteed by design and characterization for -40°C < T<sub>A</sub> < +85°C.

**Note 3:** The DNL and INL are measured with the potentiometer configured as a voltage-divider with H<sub>-</sub> = V<sub>DD</sub> and L<sub>-</sub> = GND. The wiper terminal is unloaded and measured with a high-input-impedance voltmeter.

**Note 4:** The DNL and INL are measured with the potentiometer configured as a variable resistor. H<sub>-</sub> is unconnected and L<sub>-</sub> = GND. For V<sub>DD</sub> = +5V, the wiper is driven with 400μA (MAX5477), 80μA (MAX5478), or 40μA (MAX5479). For V<sub>DD</sub> = +3V, the wiper is driven with 200μA (MAX5477), 40μA (MAX5478), or 20μA (MAX5479).

**Note 5:** The wiper resistance is measured using the source currents given in Note 3.

**Note 6:** The devices draw current in excess of the specified supply current when the digital inputs are driven with voltages between (V<sub>DD</sub> - 0.5V) and (GND + 0.5V). See Supply Current vs. Digital Input Voltage in the *Typical Operating Characteristics*.

**Note 7:** Wiper at midscale with a 10pF load (DC measurement). L<sub>-</sub> = GND, an AC source is applied to H<sub>-</sub>, and the W<sub>-</sub> output is measured. A 3dB bandwidth occurs when the AC W<sub>-</sub>/H<sub>-</sub> value is 3dB lower than the DC W<sub>-</sub>/H<sub>-</sub> value.

**Note 8:** The programming current exists only during power-up and EEPROM writes.

**Note 9:** The SCL clock period includes rise and fall times (t<sub>R</sub> = t<sub>F</sub>). All digital input signals are specified with t<sub>R</sub> = t<sub>F</sub> = 2ns and timed from a voltage level of (V<sub>IL</sub> + V<sub>IH</sub>) / 2.

**Note 10:** Digital timing is guaranteed by design and characterization, and is not production tested.

**Note 11:** This is measured from the STOP pulse to the time it takes the output to reach 50% of the output step size (divider mode). It is measured with a maximum external capacitive load of 10pF.

**Note 12:** An appropriate bus pullup resistance must be selected depending on board capacitance. Refer to the I<sup>2</sup>C-bus specification document linked to this web address: [www.semiconductors.philips.com/acrobat/literature/9398/39340011.pdf](http://www.semiconductors.philips.com/acrobat/literature/9398/39340011.pdf)

**Note 13:** The idle time begins from the initiation of the STOP pulse.

# Dual, 256-Tap, Nonvolatile, I<sup>2</sup>C-Interface, Digital Potentiometers

## Typical Operating Characteristics

(V<sub>DD</sub> = +5V, H<sub>-</sub> = V<sub>DD</sub>, L<sub>-</sub> = GND, T<sub>A</sub> = +25°C, unless otherwise noted.)

MAX5477/MAX5478/MAX5479

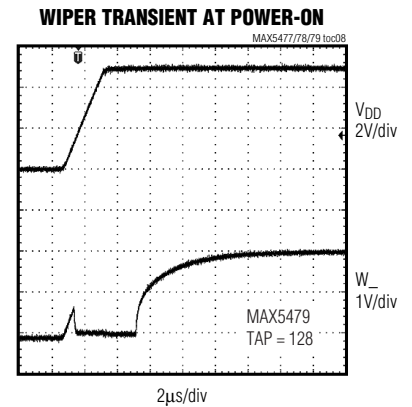
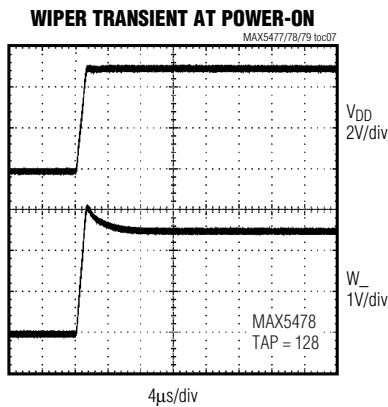
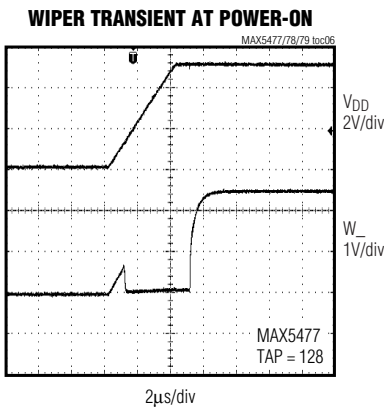
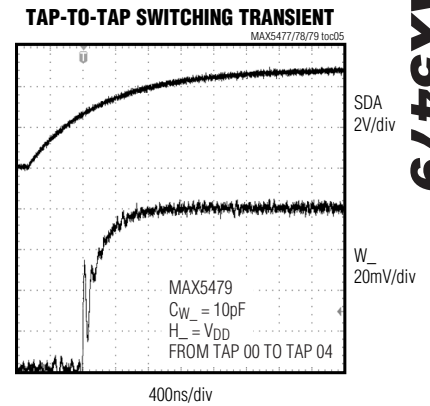
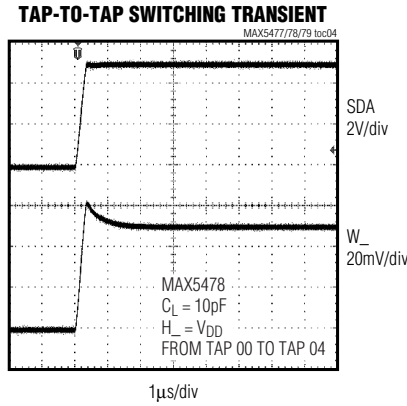
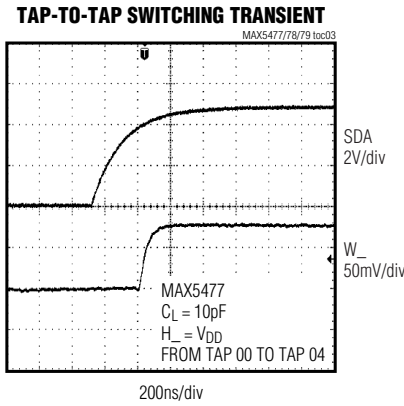
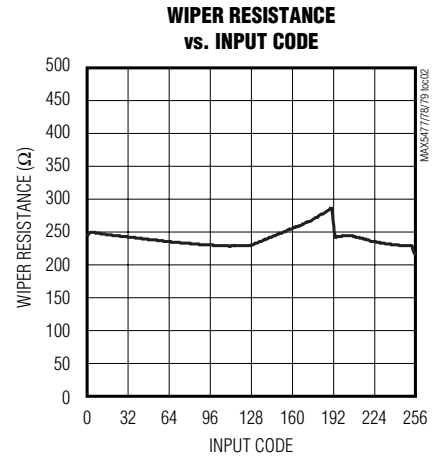
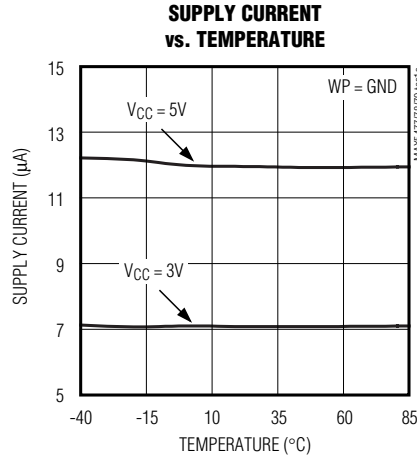
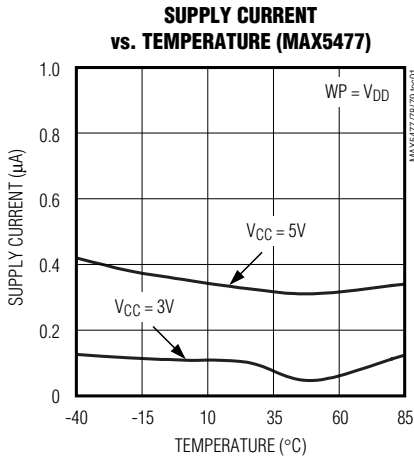

# Dual, 256-Tap, Nonvolatile, I<sup>2</sup>C-Interface, Digital Potentiometers

## Typical Operating Characteristics (continued)

(V<sub>DD</sub> = +5V, H<sub>L</sub> = V<sub>DD</sub>, L<sub>L</sub> = GND, T<sub>A</sub> = +25°C, unless otherwise noted.)

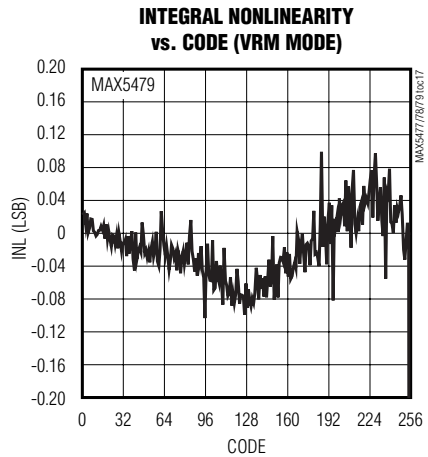
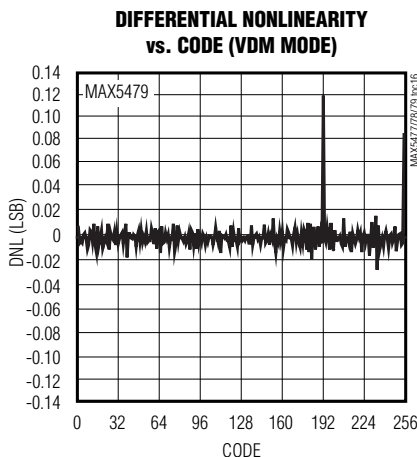
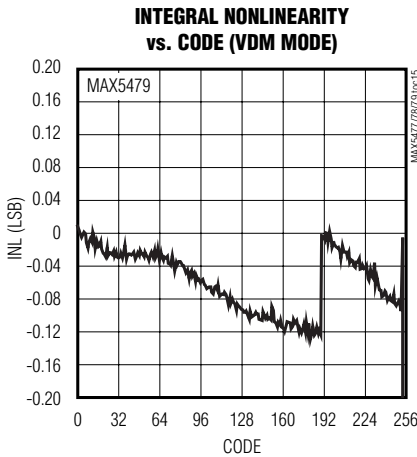
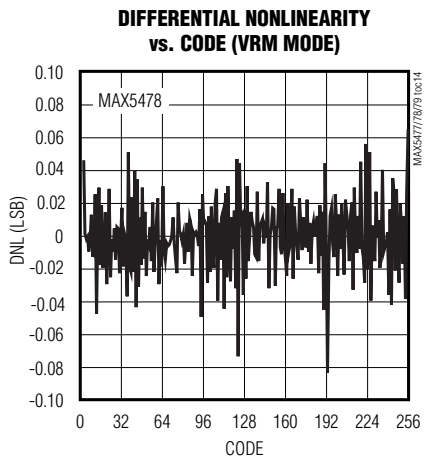
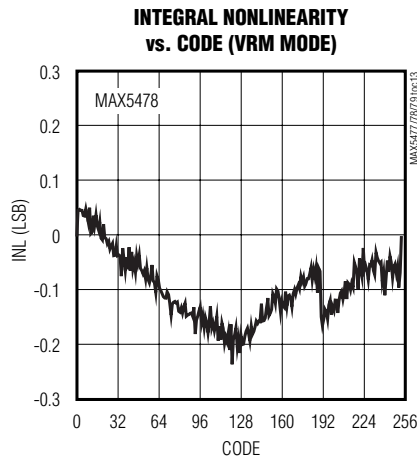
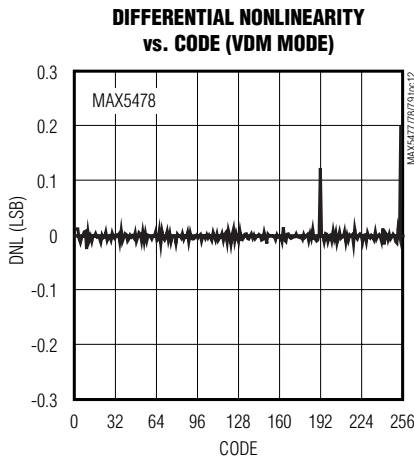
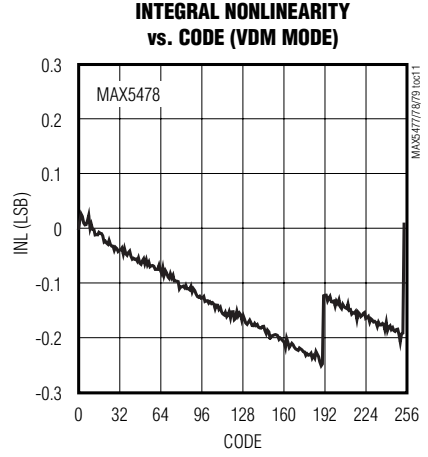
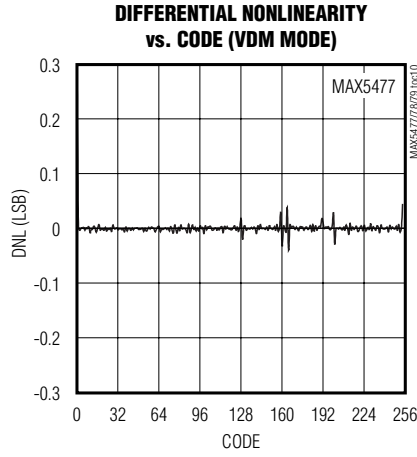
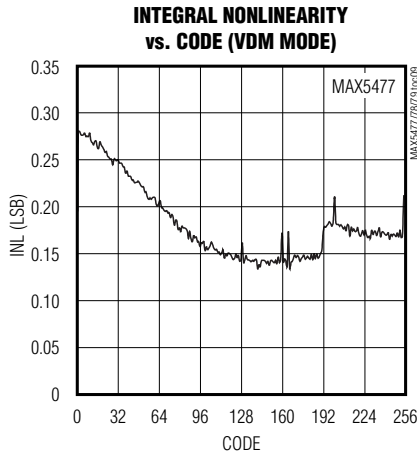

# Dual, 256-Tap, Nonvolatile, I<sup>2</sup>C-Interface, Digital Potentiometers

## Typical Operating Characteristics (continued)

(V<sub>DD</sub> = +5V, H<sub>L</sub> = V<sub>DD</sub>, L<sub>L</sub> = GND, T<sub>A</sub> = +25°C, unless otherwise noted.)

MAX5477/MAX5478/MAX5479

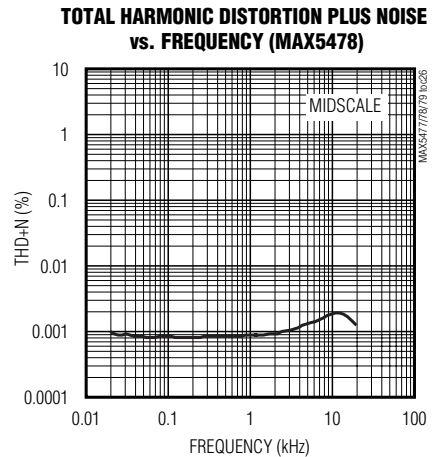
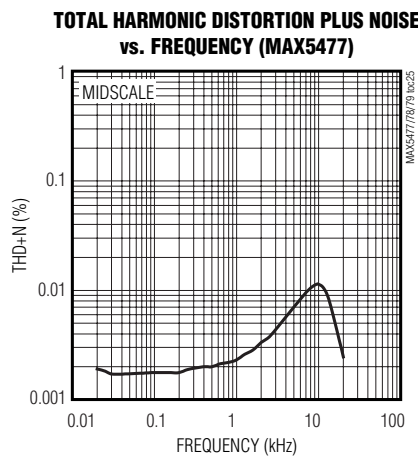
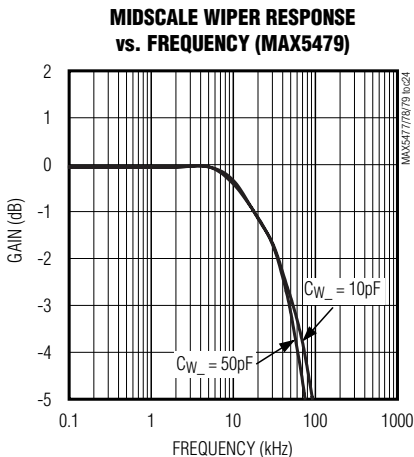
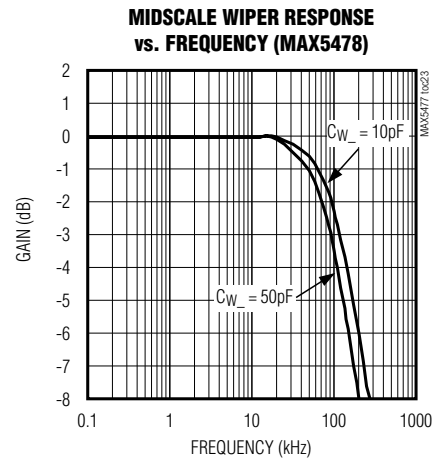
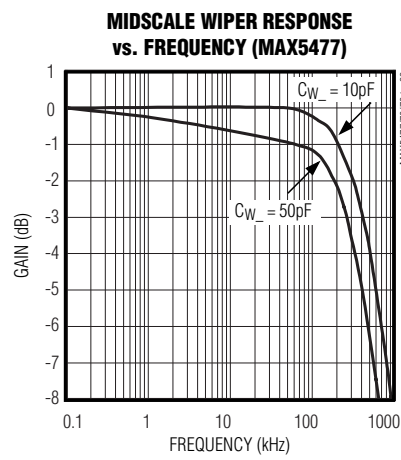
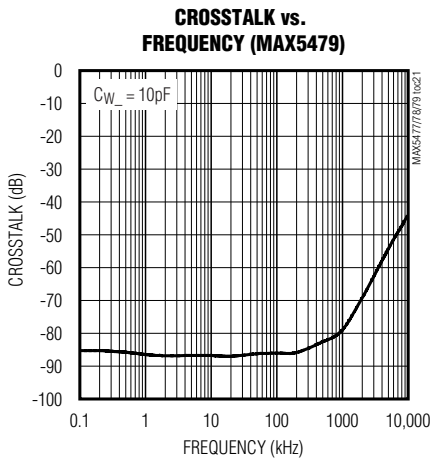
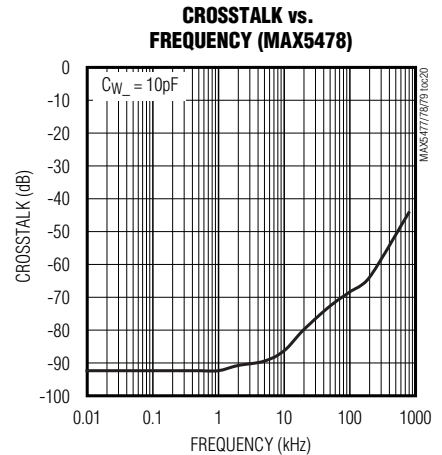
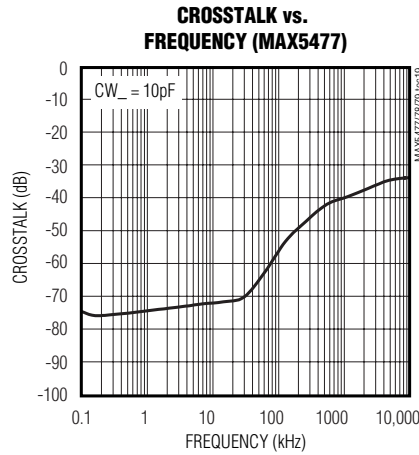
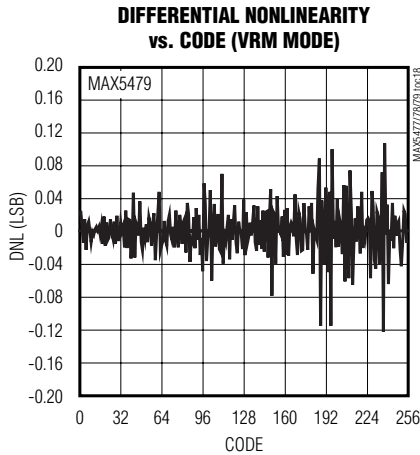

# Dual, 256-Tap, Nonvolatile, I<sup>2</sup>C-Interface, Digital Potentiometers

## Typical Operating Characteristics (continued)

(V<sub>DD</sub> = +5V, H<sub>L</sub> = V<sub>DD</sub>, L<sub>L</sub> = GND, T<sub>A</sub> = +25°C, unless otherwise noted.)

**TOTAL HARMONIC DISTORTION PLUS NOISE vs. FREQUENCY (MAX5479)**

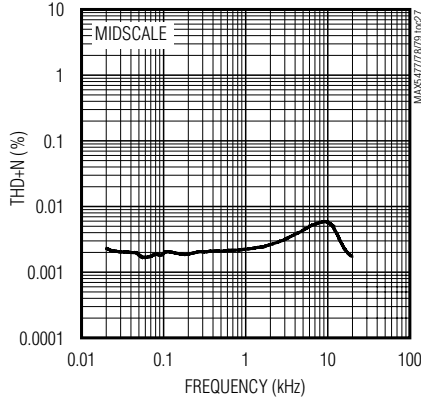

**END-TO-END RESISTANCE % CHANGE vs. TEMPERATURE (MAX5477)**

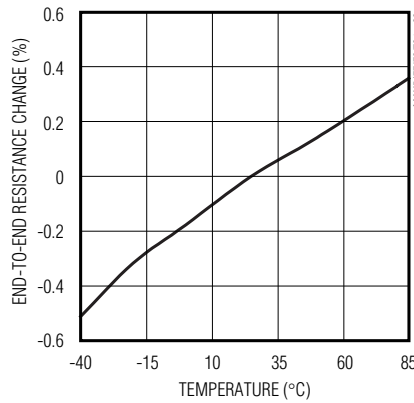

**END-TO-END RESISTANCE % CHANGE vs. TEMPERATURE (MAX5478)**

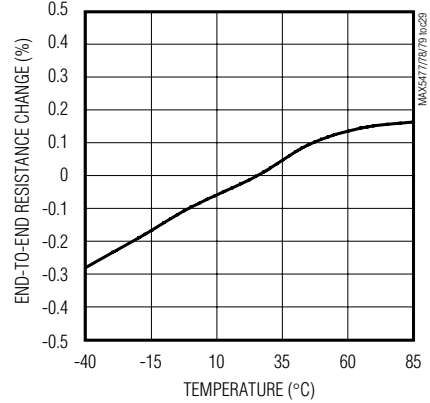

**END-TO-END RESISTANCE % CHANGE vs. TEMPERATURE (MAX5479)**

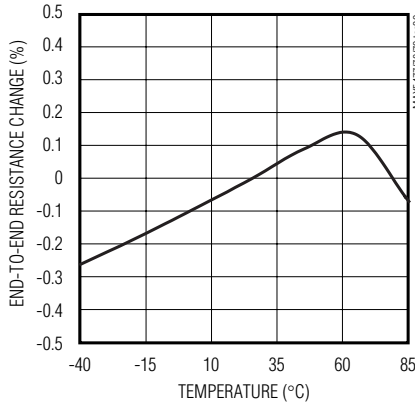

**SUPPLY CURRENT vs. DIGITAL INPUT VOLTAGE**

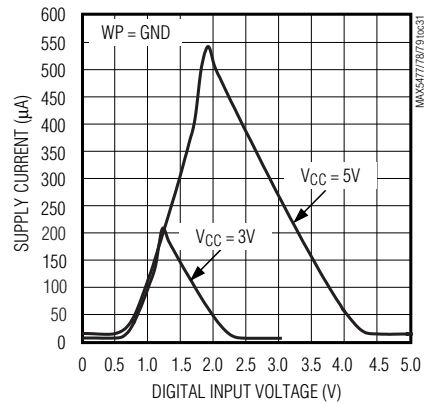



# Dual, 256-Tap, Nonvolatile, I<sup>2</sup>C-Interface, Digital Potentiometers

## Pin Description

MAX5477/MAX5478/MAX5479

PIN		NAME	FUNCTION
TSSOP	THIN QFN		
1	15	HA	Potentiometer A High Terminal
2	14	WA	Potentiometer A Wiper Terminal
3	13	LA	Potentiometer A Low Terminal
4	12	HB	Potentiometer B High Terminal
5	11	WB	Potentiometer B Wiper Terminal
6	10	LB	Potentiometer B Low Terminal
7	9	WP	Write-Protect Input. Connect to GND to allow changes to the wiper position and the data stored in the EEPROM. Connect to V <sub>DD</sub> or leave unconnected to enable the write protection of the EEPROM. See the <i>Write Protect (WP)</i> section for operating instructions.
8	7	GND	Ground
9	6	A2	Address Input 2. Connect to V <sub>DD</sub> or GND (see Table 1).
10	5	A1	Address Input 1. Connect to V <sub>DD</sub> or GND (see Table 1).
11	4	A0	Address Input 0. Connect to V <sub>DD</sub> or GND (see Table 1).
12	3	SDA	I <sup>2</sup> C Serial Data
13	2	SCL	I <sup>2</sup> C Clock Input
14	1	V <sub>DD</sub>	Power-Supply Input. Connect a +2.7V to +5.25V power supply to V <sub>DD</sub> and bypass V <sub>DD</sub> to GND with a 0.1μF capacitor installed as close to the device as possible.
—	8, 16	N.C.	No Connection. Do not connect.
—	EP	EP	Exposed Paddle. Do not connect.

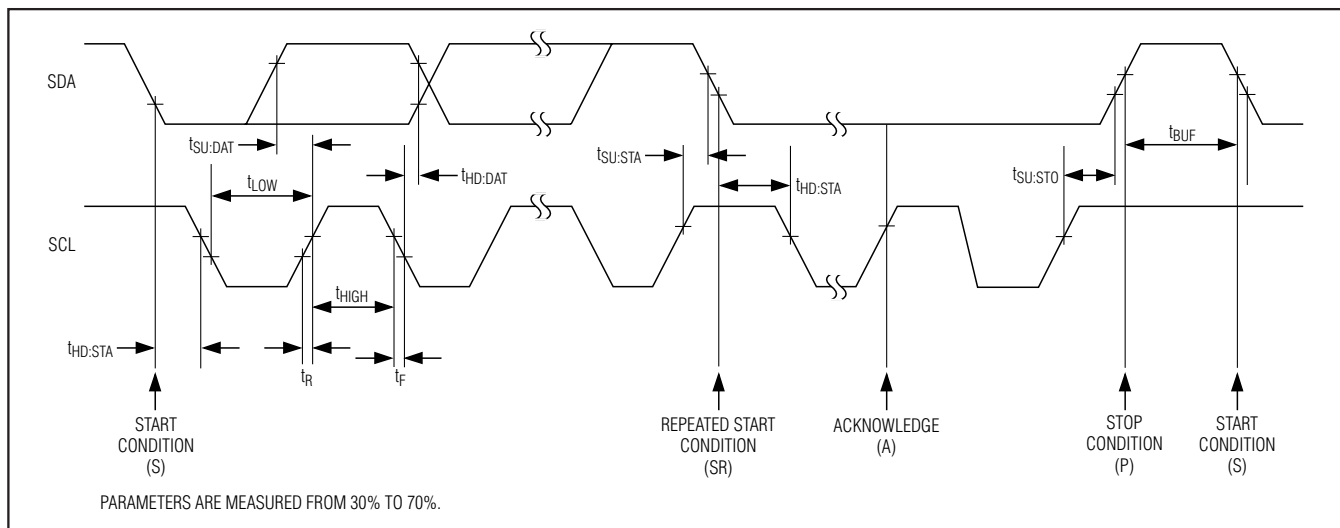

Figure 1. I<sup>2</sup>C Serial-Interface Timing Diagram

# Dual, 256-Tap, Nonvolatile, I<sup>2</sup>C-Interface, Digital Potentiometers

## Detailed Description

The MAX5477/MAX5478/MAX5479 contain two resistor arrays with 255 elements in each array. The MAX5477 has a total end-to-end resistance of 10k $\Omega$ , the MAX5478 has an end-to-end resistance of 50k $\Omega$ , and the MAX5479 has an end-to-end resistance of 100k $\Omega$ . The MAX5477/MAX5478/MAX5479 provide access to the high, low, and wiper terminals for a standard voltage-divider configuration. Connect H<sub>-</sub>, L<sub>-</sub>, and W<sub>-</sub> in any desired configuration as long as their voltages remain between GND and V<sub>DD</sub>.

A simple 2-wire I<sup>2</sup>C-compatible serial interface moves the wiper among the 256 tap points (Figure 2). A non-volatile memory stores the wiper position and recalls the stored wiper position upon power-up. The non-volatile memory is guaranteed for 50 years for wiper data retention and up to 200,000 wiper store cycles.

**Table 1. Slave Addresses**

ADDRESS INPUTS			SLAVE ADDRESS
A2	A1	A0	
GND	GND	GND	0101000
GND	GND	V <sub>DD</sub>	0101001
GND	V <sub>DD</sub>	GND	0101010
GND	V <sub>DD</sub>	V <sub>DD</sub>	0101011
V <sub>DD</sub>	GND	GND	0101100
V <sub>DD</sub>	GND	V <sub>DD</sub>	0101101
V <sub>DD</sub>	V <sub>DD</sub>	GND	0101110
V <sub>DD</sub>	V <sub>DD</sub>	V <sub>DD</sub>	0101111

## Analog Circuitry

The MAX5477/MAX5478/MAX5479 consist of two resistor arrays with 255 resistive elements; 256 tap points are accessible to the wipers, along the resistor string between H<sub>-</sub> and L<sub>-</sub>. The wiper tap point is selected by programming the potentiometer through the I<sup>2</sup>C interface. An address byte, a command byte, and 8 data bits program the wiper position for each potentiometer. The H<sub>-</sub> and L<sub>-</sub> terminals of the MAX5477/MAX5478/MAX5479 are similar to the two end terminals of a mechanical potentiometer. The MAX5477/MAX5478/MAX5479 feature power-on reset circuitry that loads the wiper position from the nonvolatile memory at power-up.

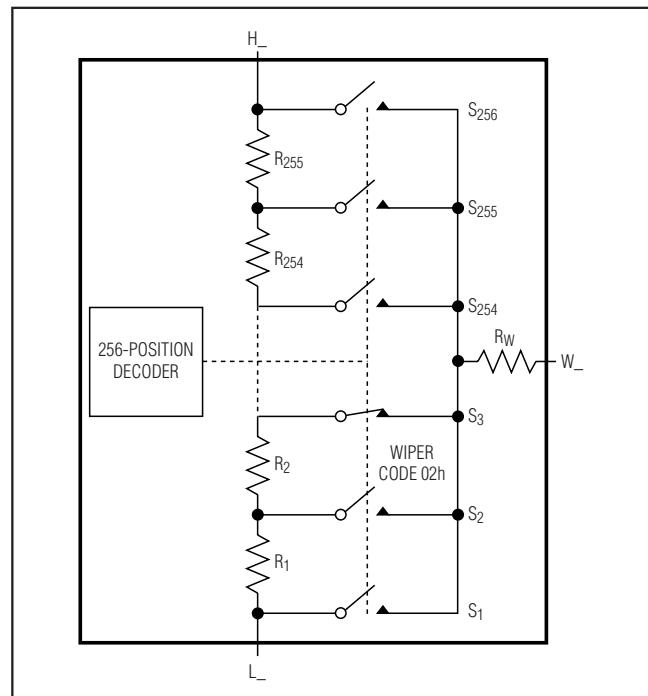

Figure 2. Potentiometer Configuration

# Dual, 256-Tap, Nonvolatile, I<sup>2</sup>C-Interface, Digital Potentiometers

MAX5477/MAX5478/MAX5479

**Table 2. Write-Protect Behavior of VREG and NVREG**

COMMAND	WP = 0	WP = 1
Write to VREG	I <sup>2</sup> C data is written to VREG. Wiper position updates with I <sup>2</sup> C data. No change to NVREG.	Copy NVREG to VREG. Wiper position updates with NVREG data. No change to NVREG.
Write to NVREG	No change to VREG or wiper position. I <sup>2</sup> C data is written to NVREG.	No change to VREG or wiper position. No change to NVREG.
Copy NVREG to VREG	Copy NVREG to VREG. Wiper position updates with NVREG data. No change to NVREG.	Copy NVREG to VREG. Wiper position updates with NVREG data. No change to NVREG.
Copy VREG to NVREG	Copy VREG to NVREG. No change to VREG or wiper position.	No change to VREG or wiper position. No change to NVREG.

**Table 3. Command Byte Summary**

SCL CYCLE NUMBER	START (S)	ADDRESS BYTE								COMMAND BYTE								DATA BYTE								STOP (P)	NOTES		
		1 A6	2 A5	3 A4	4 A3	5 A2	6 A1	7 A0	8	9 ACK (A)	10	11 TX	12 NV	13 V	14 R3	15 R2	16 R1	17 R0	18 ACK (A)	19 D7	20 D6	21 D5	22 D4	23 D3	24 D2			25 D1	26 D0
VREG		0	1	0	1	A2	A1	A0	0		0	0	0	1	0	0	0	1		D7	D6	D5	D4	D3	D2	D1	D0		
NVREG		0	1	0	1	A2	A1	A0	0		0	0	1	0	0	0	0	1		D7	D6	D5	D4	D3	D2	D1	D0		WIPER A ONLY
NVREGxVREG		0	1	0	1	A2	A1	A0	0		0	1	1	0	0	0	0	1		D7	D6	D5	D4	D3	D2	D1	D0		
VREGxNVREG		0	1	0	1	A2	A1	A0	0		0	1	0	1	0	0	0	1		D7	D6	D5	D4	D3	D2	D1	D0		
VREG		0	1	0	1	A2	A1	A0	0		0	0	0	1	0	0	1	0		D7	D6	D5	D4	D3	D2	D1	D0		WIPER B ONLY
NVREG		0	1	0	1	A2	A1	A0	0		0	0	1	0	0	0	1	0		D7	D6	D5	D4	D3	D2	D1	D0		
NVREGxVREG		0	1	0	1	A2	A1	A0	0		0	1	1	0	0	0	1	0		D7	D6	D5	D4	D3	D2	D1	D0		
VREGxNVREG		0	1	0	1	A2	A1	A0	0		0	1	0	1	0	0	1	0		D7	D6	D5	D4	D3	D2	D1	D0		
VREG		0	1	0	1	A2	A1	A0	0		0	0	0	1	0	0	1	1		D7	D6	D5	D4	D3	D2	D1	D0		WIPERS A AND B
NVREG		0	1	0	1	A2	A1	A0	0		0	0	1	0	0	0	1	1		D7	D6	D5	D4	D3	D2	D1	D0		
NVREGxVREG		0	1	0	1	A2	A1	A0	0		0	1	1	0	0	0	1	1		D7	D6	D5	D4	D3	D2	D1	D0		
VREGxNVREG		0	1	0	1	A2	A1	A0	0		0	1	0	1	0	0	1	1		D7	D6	D5	D4	D3	D2	D1	D0		

### Digital Interface

The MAX5477/MAX5478/MAX5479 feature an internal, nonvolatile EEPROM that stores the wiper state for initialization during power-up. The shift register decodes the command and address bytes, routing the data to the proper memory registers. Data written to a volatile memory register immediately updates the wiper position, or writes data to a nonvolatile register for storage (see Table 3).

The volatile register retains data as long as the device is powered. Removing power clears the volatile register. The nonvolatile register retains data even after power is removed. Upon power-up, the power-on reset circuitry controls the transfer of data from the nonvolatile register to the volatile register.

### Write Protect (WP)

A write-protect feature prevents accidental overwriting of the EEPROM. Connect WP to V<sub>DD</sub> or leave unconnected to prevent any EEPROM write cycles. Writing to the volatile register (VREG) while WP = 1 updates the wiper position with the protected data stored in the nonvolatile register (NVREG). Connect WP to GND to allow write commands to the EEPROM and to update the wiper position from either the value in the EEPROM or directly from the I<sup>2</sup>C interface (Table 2). Connecting WP to GND increases the supply current by 19.6µA (max).

To ensure a fail-safe, write-protect feature, write the data to be protected to both the nonvolatile and volatile registers before pulling WP high. Releasing WP (WP = 0) and sending partial or invalid I<sup>2</sup>C commands (such as single-byte address polling) can load the volatile

# Dual, 256-Tap, Nonvolatile, I<sup>2</sup>C-Interface, Digital Potentiometers

register with input shift register data and change the wiper position. Use valid 3-byte I<sup>2</sup>C commands for proper operation. This precautionary operation is necessary only when transitioning from write protected (WP = 1) to not write protected (WP = 0).

## Serial Addressing

The MAX5477/MAX5478/MAX5479 operate as slave devices that send and receive data through an I<sup>2</sup>C-/SMBus™-compatible 2-wire serial interface. The interface uses a serial data access (SDA) line and a serial clock line (SCL) to achieve bidirectional communication between master(s) and slave(s). A master, typically a microcontroller, initiates all data transfers to the MAX5477/MAX5478/MAX5479, and generates the SCL clock that synchronizes the data transfer (Figure 1).

The MAX5477/MAX5478/MAX5479 SDA line operates as both an input and an open-drain output. The SDA line requires a pullup resistor, typically 4.7k $\Omega$ . The MAX5477/MAX5478/MAX5479 SCL line operates only as an input. The SCL line requires a pullup resistor (typically 4.7k $\Omega$ ) if there are multiple masters on the 2-wire interface, or if the master in a single-master system has an open-drain SCL output. SCL and SDA should not exceed V<sub>DD</sub> in a mixed-voltage system, despite the open-drain drivers.

Each transmission consists of a START (S) condition (Figure 3) sent by a master, followed by the MAX5477/MAX5478/MAX5479 7-bit slave address plus the NOP/ $\bar{W}$  bit (Figure 4), 1 command byte and 1 data byte, and finally a STOP (P) condition (Figure 3).

## START and STOP Conditions

Both SCL and SDA remain high when the interface is not busy. A master controller signals the beginning of a transmission with a START condition by transitioning SDA from high to low while SCL is high. The master controller issues a STOP condition by transitioning the SDA from low to high while SCL is high, when it finishes

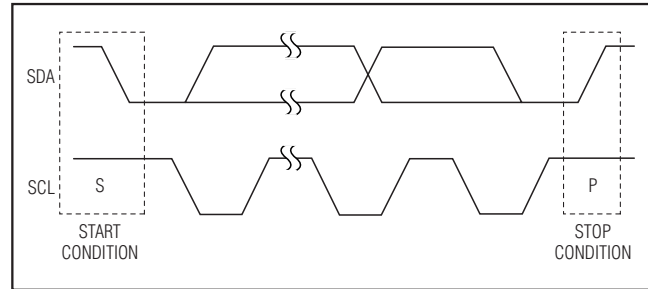

Figure 3. START and STOP Conditions

communicating with the slave. The bus is then free for another transmission (Figure 3).

## Bit Transfer

One data bit is transferred during each clock pulse. The data on the SDA line must remain stable while SCL is high (Figure 5).

## Acknowledge

The acknowledge bit is a clocked 9th bit that the recipient uses to handshake receipt of each byte of data (Figure 6). Thus, each byte transferred effectively requires 9 bits. The master controller generates the 9th clock pulse, and the recipient pulls down SDA during the acknowledge clock pulse, so the SDA line remains stable low during the high period of the clock pulse.

## Slave Address

The MAX5477/MAX5478/MAX5479 have a 7-bit-long slave address (Figure 4). The 8th bit following the 7-bit slave address is the NOP/ $\bar{W}$  bit. Set the NOP/ $\bar{W}$  bit low for a write command and high for a no-operation command.

The MAX5477/MAX5478/MAX5479 provide three address inputs (A0, A1, and A2), allowing up to eight devices to share a common bus (Table 1). The first 4 bits (MSBs) of the MAX5477/MAX5478/MAX5479 slave addresses are always 0101. A2, A1, and A0 set the next

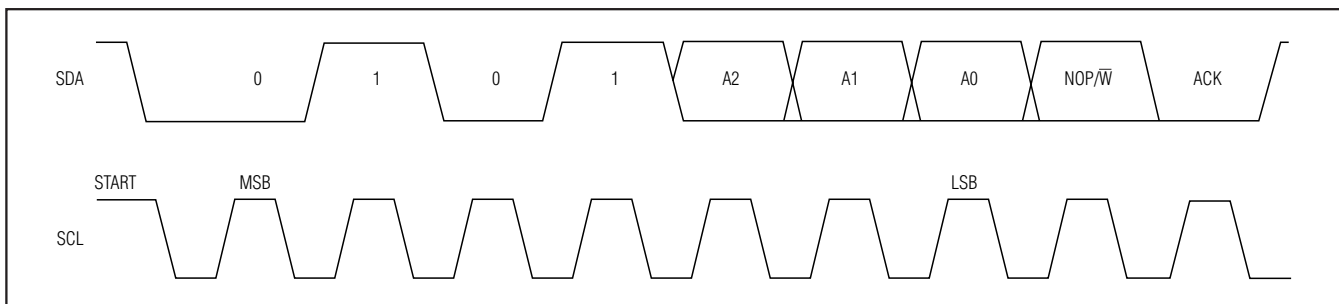

Figure 4. Slave Address

SMBus is a trademark of Intel Corporation.

# Dual, 256-Tap, Nonvolatile, I<sup>2</sup>C-Interface, Digital Potentiometers

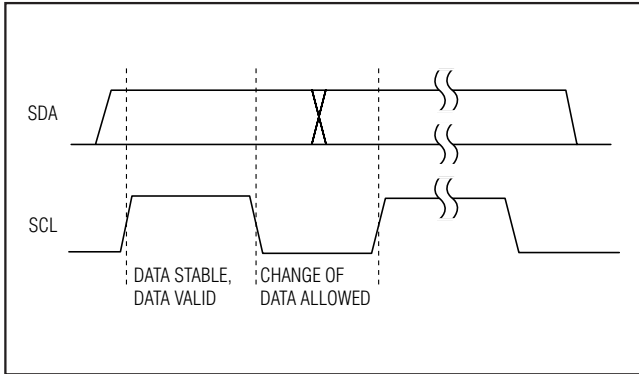

Figure 5. Bit Transfer

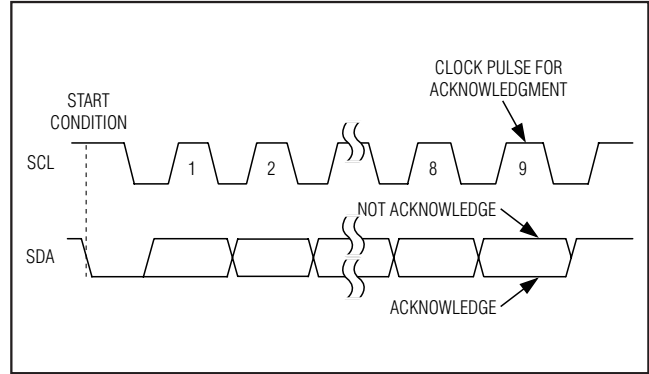

Figure 6. Acknowledge

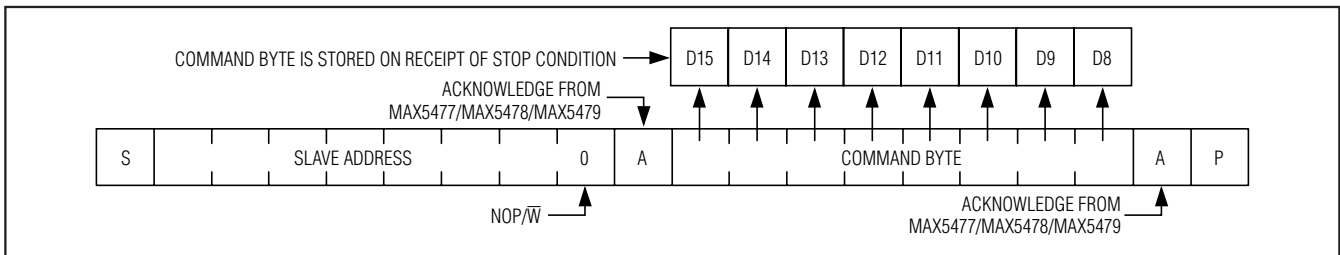

Figure 7. Command Byte Received

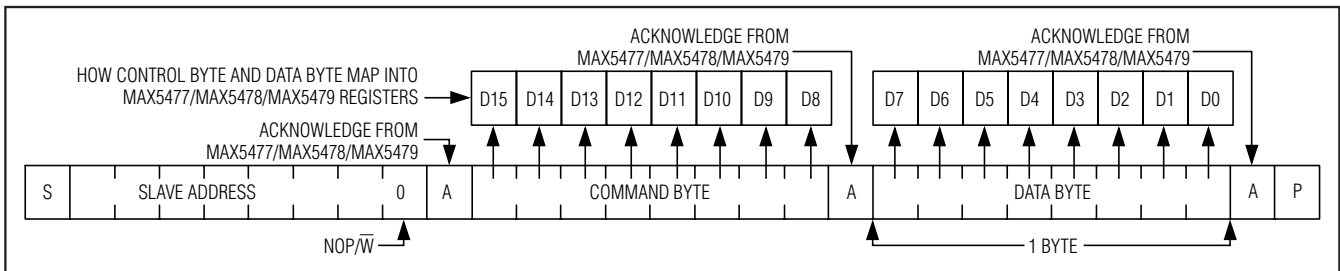

Figure 8. Command and Single Data Byte Received

3 bits in the slave address. Connect each address input to V<sub>DD</sub> or GND to set these 3 bits. Each device must have a unique address to share a common bus.

### Message Format for Writing

Write to the MAX5477/MAX5478/MAX5479 by transmitting the device's slave address with NOP/W (8th bit) set to zero, followed by at least 1 byte of information (Figure 7). The 1st byte of information is the command byte. The bytes received after the command byte are the data bytes. The 1st data byte goes into the internal register of the MAX5477/MAX5478/MAX5479 as selected by the command byte (Figure 8).

### Command Byte

Use the command byte to select the source and destination of the wiper data (nonvolatile or volatile memory registers) and swap data between nonvolatile and volatile memory registers (see Table 3).

### Command Descriptions

VREG: The data byte writes to the volatile memory register and the wiper position updates with the data in the volatile memory register.

NVREG: The data byte writes to the nonvolatile memory register. The wiper position is unchanged.

NVREGxVREG: Data transfers from the nonvolatile memory register to the volatile memory register (wiper position updates).

# Dual, 256-Tap, Nonvolatile, I<sup>2</sup>C-Interface, Digital Potentiometers

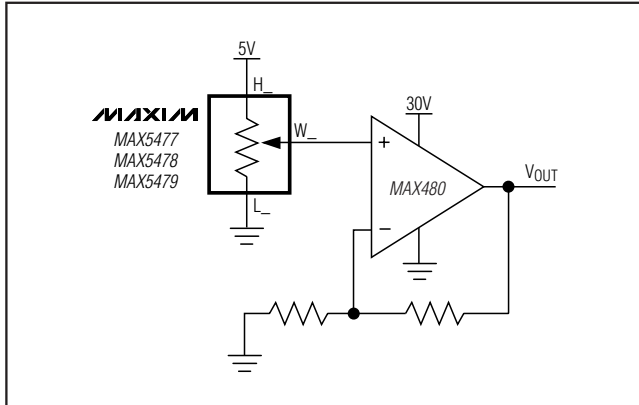

Figure 9. Positive LCD Bias Control Using a Voltage-Divider

VREGxNVREG: Data transfers from the volatile memory register into the nonvolatile memory register.

### Nonvolatile Memory

The internal EEPROM consists of a 16-bit nonvolatile register that retains the value written to it prior to power down. The nonvolatile register is programmed with the midscale value at the factory. The nonvolatile memory is guaranteed for 50 years for wiper position retention and up to 200,000 wiper write cycles. A write-protect feature prevents accidental overwriting of the EEPROM. Connect WP to V<sub>DD</sub> or leave open to enable the write-protect feature. The wiper position only updates with the value in the EEPROM when WP = V<sub>DD</sub>. Connect WP to GND to allow EEPROM write cycles and to update the wiper position from nonvolatile memory or directly from the I<sup>2</sup>C serial interface.

### Power-Up

Upon power-up, the MAX5477/MAX5478/MAX5479 load the data stored in the nonvolatile memory register into the volatile memory register, updating the wiper position with the data stored in the nonvolatile memory register. This initialization period takes 10μs.

### Standby

The MAX5477/MAX5478/MAX5479 feature a low-power standby mode. When the device is not being programmed, it enters into standby mode and supply current drops to 500nA (typ).

### Applications Information

The MAX5477/MAX5478/MAX5479 are ideal for circuits requiring digitally controlled adjustable resistance, such as LCD contrast control (where voltage biasing adjusts the display contrast), or for programmable filters with adjustable gain and/or cutoff frequency.

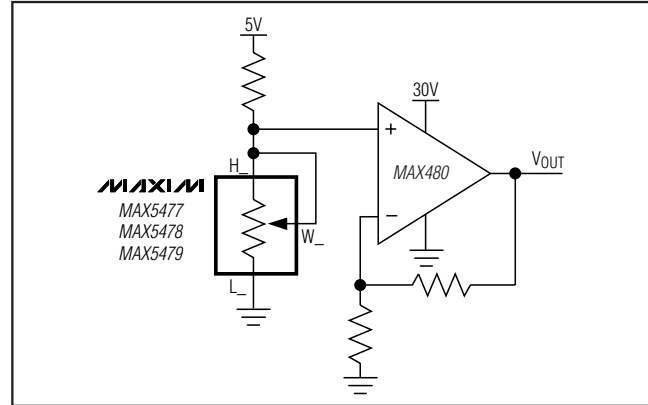

Figure 10. Positive LCD Bias Control Using a Variable Resistor

### Positive LCD Bias Control

Figures 9 and 10 show an application where the MAX5477/MAX5478/MAX5479 provide an adjustable, positive LCD bias voltage. The op amp provides buffering and gain to the resistor-divider network made by the potentiometer (Figure 9) or by a fixed resistor and a variable resistor (see Figure 10).

### Programmable Filter

Figure 11 shows the MAX5477/MAX5478/MAX5479 in a 1st-order programmable application filter. Adjust the gain of the filter with R<sub>2</sub>, and set the cutoff frequency with R<sub>3</sub>. Use the following equations to calculate the gain (A) and the -3dB cutoff frequency (f<sub>C</sub>):

$$A = 1 + \frac{R_1}{R_2}$$

$$f_C = \frac{1}{2\pi \times R_3 \times C}$$

### Offset Voltage and Gain Adjustment

Connect the high and low terminals of one potentiometer of a MAX5477 between the NULL inputs of a MAX410 and the wiper to the op amp's positive supply to nullify the offset voltage over the operating temperature range. Install the other potentiometer in the feedback path to adjust the gain of the MAX410 (Figure 12).

### Adjustable Voltage Reference

Figure 13 shows the MAX5477/MAX5478/MAX5479 used as the feedback resistors in multiple adjustable voltage reference applications. Independently adjust the output voltages of the MAX6160 parts from 1.23V to V<sub>IN</sub> - 0.2V by changing the wiper positions of the MAX5477/MAX5478/MAX5479.

# Dual, 256-Tap, Nonvolatile, I<sup>2</sup>C-Interface, Digital Potentiometers

MAX5477/MAX5478/MAX5479

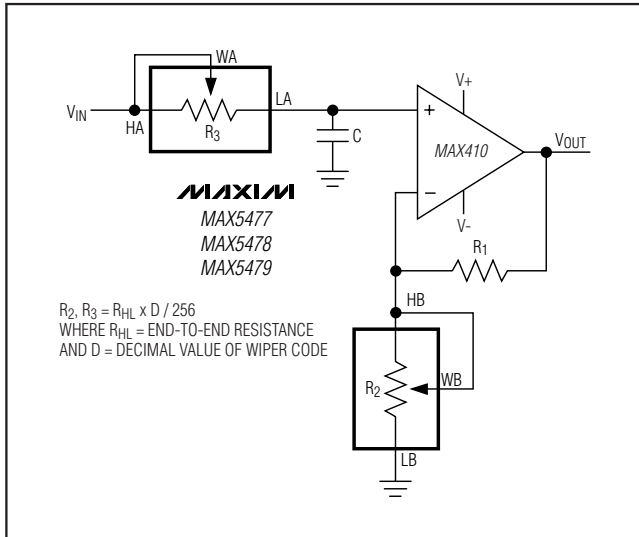

Figure 11. Programmable Filter

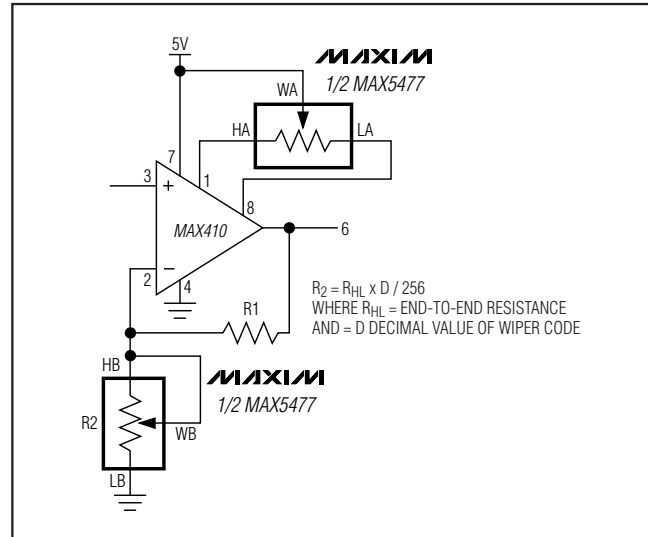

Figure 12. Offset Voltage Adjustment Circuit

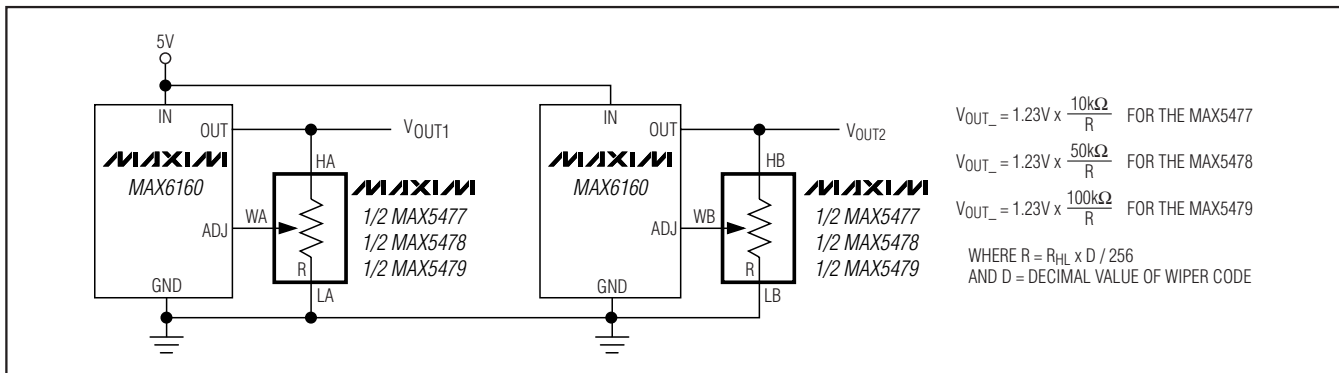
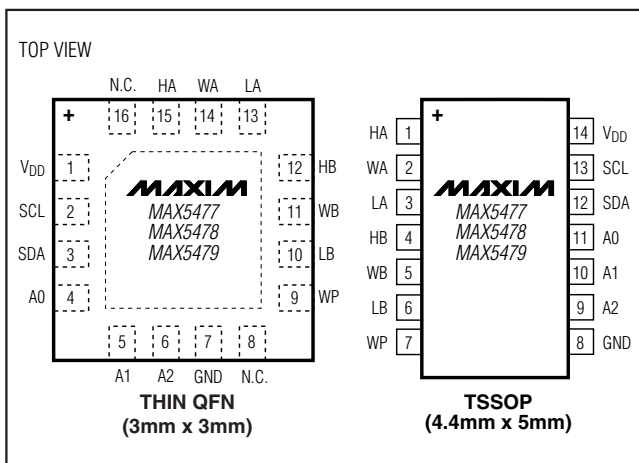

Figure 13. Adjustable Voltage Reference

## Pin Configurations



## Chip Information

PROCESS: BiCMOS

## Package Information

For the latest package outline information and land patterns (footprints), go to [www.maxim-ic.com/packages](http://www.maxim-ic.com/packages). Note that a "+", "#", or "-" in the package code indicates RoHS status only. Package drawings may show a different suffix character, but the drawing pertains to the package regardless of RoHS status.

PACKAGE TYPE	PACKAGE CODE	OUTLINE NO.	LAND PATTERN NO.
16 TQFN-EP	T1633F+3	<a href="#">21-0136</a>	<a href="#">90-0033</a>
14 TSSOP	U14+1	<a href="#">21-0066</a>	<a href="#">90-0113</a>

# Dual, 256-Tap, Nonvolatile, I<sup>2</sup>C-Interface, Digital Potentiometers

## Revision History

REVISION NUMBER	REVISION DATE	DESCRIPTION	PAGES CHANGED
0	8/04	Initial release	—
4	1/09	Updated <i>Ordering Information</i> for lead-free information.	1
5	11/11	Released TQFN packages, revised <i>Ordering Information</i> .	1–4, 15, 16

Maxim cannot assume responsibility for use of any circuitry other than circuitry entirely embodied in a Maxim product. No circuit patent licenses are implied. Maxim reserves the right to change the circuitry and specifications without notice at any time. The parametric values (min and max limits) shown in the Electrical Characteristics table are guaranteed. Other parametric values quoted in this data sheet are provided for guidance.



Компания «Океан Электроники» предлагает заключение долгосрочных отношений при поставках импортных электронных компонентов на взаимовыгодных условиях!

Наши преимущества:

- Поставка оригинальных импортных электронных компонентов напрямую с производств Америки, Европы и Азии, а так же с крупнейших складов мира;
- Широкая линейка поставок активных и пассивных импортных электронных компонентов (более 30 млн. наименований);
- Поставка сложных, дефицитных, либо снятых с производства позиций;
- Оперативные сроки поставки под заказ (от 5 рабочих дней);
- Экспресс доставка в любую точку России;
- Помощь Конструкторского Отдела и консультации квалифицированных инженеров;
- Техническая поддержка проекта, помощь в подборе аналогов, поставка прототипов;
- Поставка электронных компонентов под контролем ВП;
- Система менеджмента качества сертифицирована по Международному стандарту ISO 9001;
- При необходимости вся продукция военного и аэрокосмического назначения проходит испытания и сертификацию в лаборатории (по согласованию с заказчиком);
- Поставка специализированных компонентов военного и аэрокосмического уровня качества (Xilinx, Altera, Analog Devices, Intersil, Interpoint, Microsemi, Actel, Aeroflex, Peregrine, VPT, Syfer, Eurofarad, Texas Instruments, MS Kennedy, Miteq, Cobham, E2V, MA-COM, Hittite, Mini-Circuits, General Dynamics и др.);

Компания «Океан Электроники» является официальным дистрибьютором и эксклюзивным представителем в России одного из крупнейших производителей разъемов военного и аэрокосмического назначения «JONHON», а так же официальным дистрибьютором и эксклюзивным представителем в России производителя высокотехнологичных и надежных решений для передачи СВЧ сигналов «FORSTAR».



## JONHON

«JONHON» (основан в 1970 г.)

Разъемы специального, военного и аэрокосмического назначения:

(Применяются в военной, авиационной, аэрокосмической, морской, железнодорожной, горно- и нефтедобывающей отраслях промышленности)

«FORSTAR» (основан в 1998 г.)

ВЧ соединители, коаксиальные кабели, кабельные сборки и микроволновые компоненты:

(Применяются в телекоммуникациях гражданского и специального назначения, в средствах связи, РЛС, а так же военной, авиационной и аэрокосмической отраслях промышленности).



Телефон: 8 (812) 309-75-97 (многоканальный)

Факс: 8 (812) 320-03-32

Электронная почта: [ocean@oceanchips.ru](mailto:ocean@oceanchips.ru)

Web: <http://oceanchips.ru/>

Адрес: 198099, г. Санкт-Петербург, ул. Калинина, д. 2, корп. 4, лит. А