

Constant Current LED Drivers

50V 200mA

1ch Source Driver for Automotive

BD8372HFP-M BD8372EFJ-M

General Description

BD8372HFP-M and BD8372EFJ-M are LED source drivers capable of withstanding high input voltage (50V MAX). The constant current output is set by either of two external resistors. It has built-in LED open/short protection, external resistance open/short protection and overvoltage protection that can achieve high reliability. It is possible to control all LEDs together and turn OFF even if LED causes short/open in a certain row when driving two or more LEDs by using multiple ICs.

Key Specifications

- Input Voltage Range: 5.5V to 40V
- Max Output Current: 200mA(MAX)
- Output Current Accuracy: ±8%(Max)
- Operating Temperature Range: -40°C to +125°C

Packages

HRP7
HTSOP-J8

W (Typ) x D (Typ) x H (Max)
9.395mm x 10.540mm x 2.005mm
4.90mm x 6.00mm x 1.00mm

Features

- Variable form Constant- Current Source
- H/L Current Setting Switch Control
- LED Open/Short Protection Circuit Integrated
- ISET Open/Short Protection Circuit Integrated
- Overvoltage Mute and Temperature Protection Function Integrated
- Abnormal Output Detection and Output Functions (PBUS)

Applications

For automotive (Rear lamp, Interior light, etc.).



HRP7

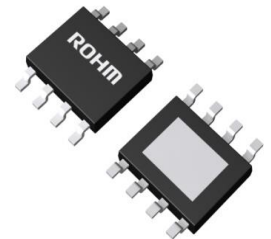

HTSOP-J8

Basic Application Circuit

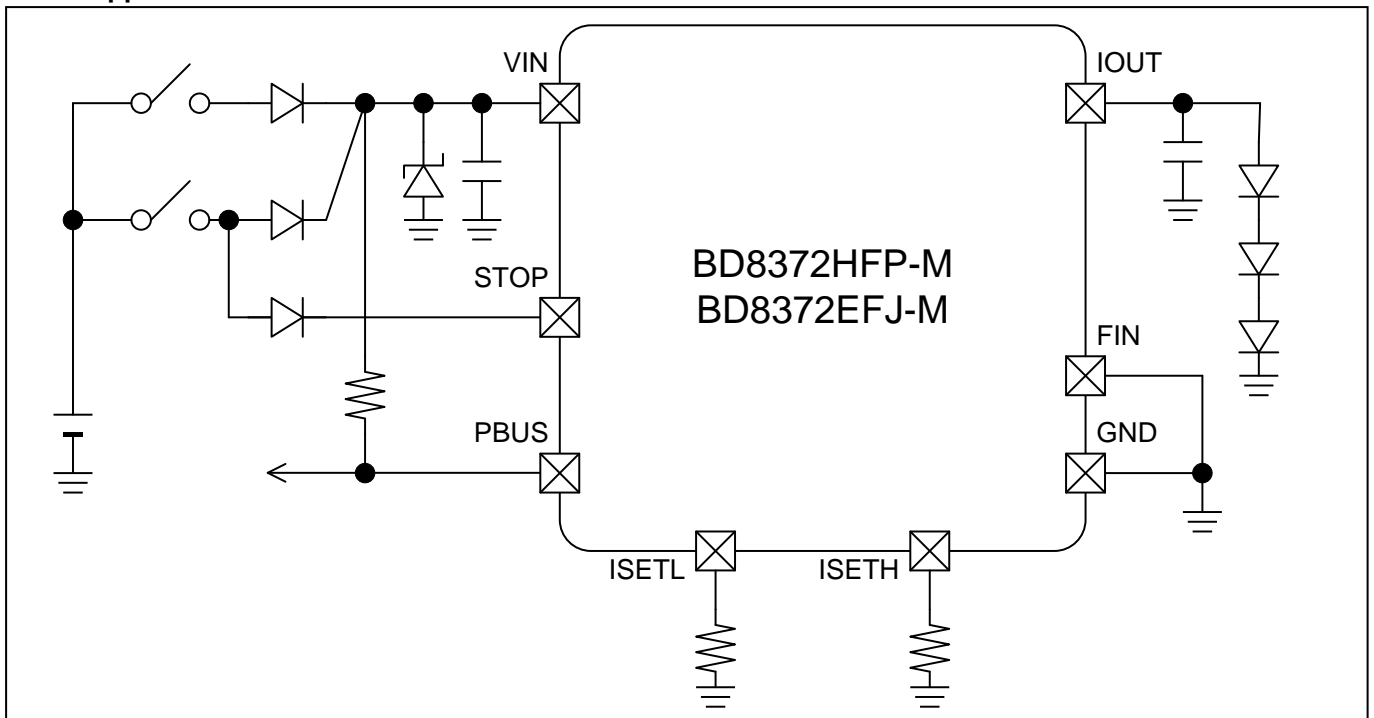

Figure 1. Typical Application Circuit

Pin Configurations

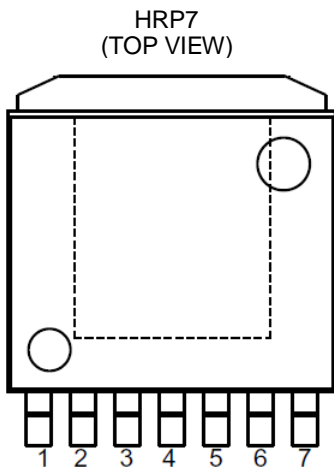

Figure 2. HRP7 Package Pin Configuration

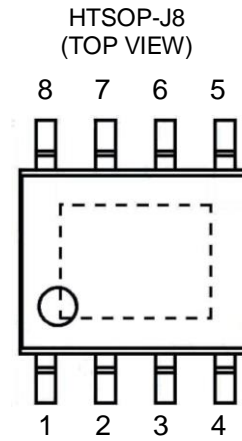

Figure 3. HTSOP-J8 Package Pin Configuration

Pin Descriptions

HRP7

Pin No.	Pin Name	Description
1	STOP	Input terminal for Brake lamp
2	PBUS	Error detection I/O terminal
3	ISETL	Current setting terminal (L mode)
4	GND	GND
5	ISETH	Current setting terminal (H mode)
6	VIN	Power supply input
7	IOUT	Current output terminal

HTSOP-J8

Pin No.	Pin Name	Description
1	VIN	Power supply input
2	IOUT	Current output terminal
3	GND	GND
4	GND	GND
5	STOP	Input terminal for Brake lamp
6	PBUS	Error detection I/O terminal
7	ISETL	Current setting terminal (L mode)
8	ISETH	Current setting terminal (H mode)

Block Diagram

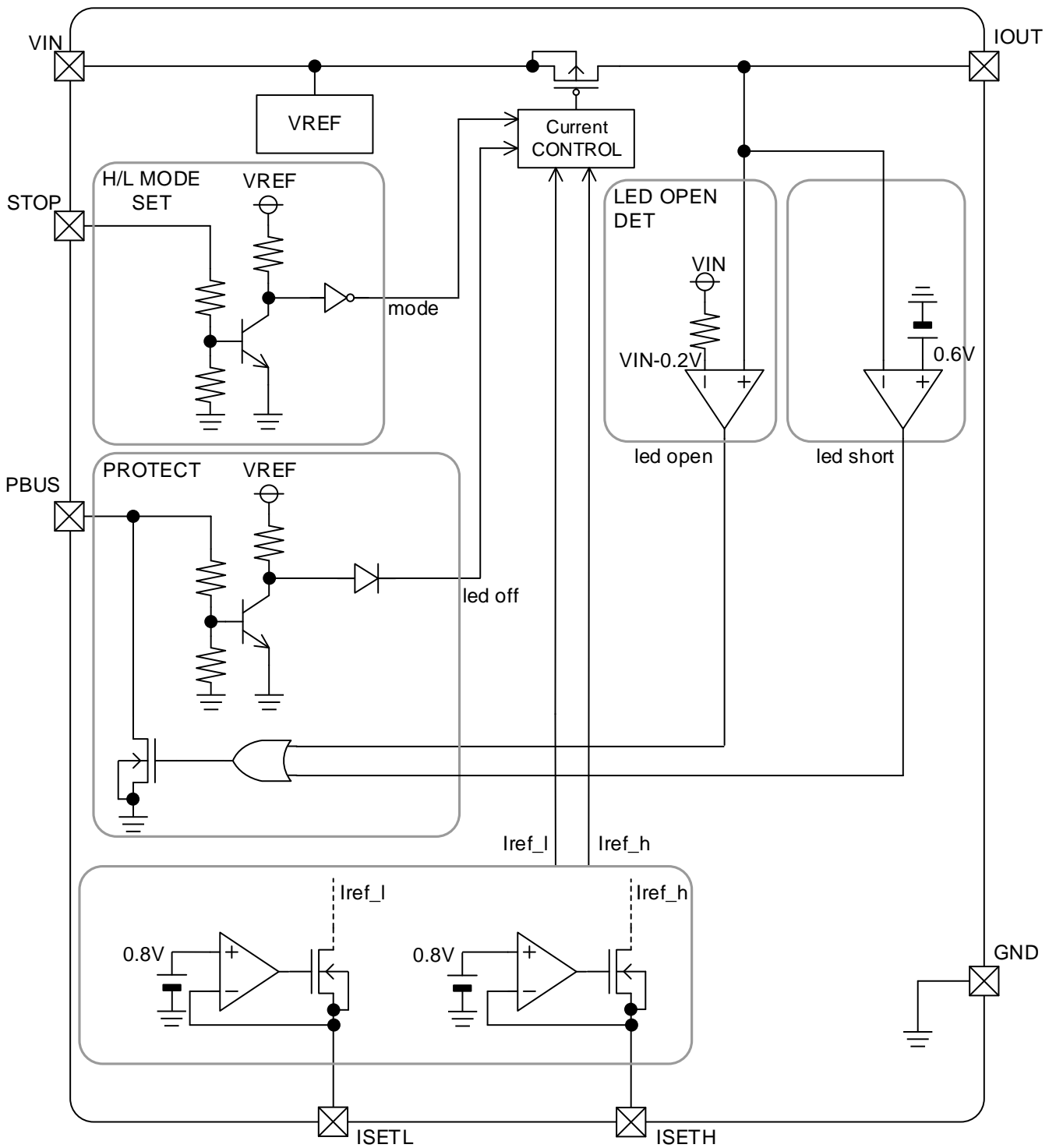

Figure 4. Block Diagram

Absolute Maximum Ratings (Ta=25°C)

Parameter	Symbol	Rating	Unit	
Power Supply Voltage	V _{IN}	-0.3 to +50	V	
STOP, IOOUT, PBUS Terminal	V _{STOP} , V _{IOOUT} , V _{PBUS}	-0.3 to V _{IN} +0.3	V	
ISETH, ISETL Terminal	V _{ISETH} , V _{ISETL}	-0.3 to +7	V	
Power Consumption	Pd	HRP7	2.3 (Note 1)	W
		HTSOP-J8	1.1 (Note 2)	
Operating Temperature Range	Topr	-40 to +125	°C	
Storage Temperature Range	Tstg	-55 to +150	°C	
Junction Temperature	Tjmax	150	°C	
IOOUT Output Maximum Current	I _{IOOUT}	200	mA	

(Note 1) HRP7

IC mounted on glass epoxy 2-layer board area 15mmx15mm of the back copper foil, measuring 70mmx70mmx1.6mm.
Pd decreased at 18.4mW/°C for temperatures above Ta=25°C.

(Note 2) HTSOP-J8

IC mounted on glass epoxy 2-layer board area 15mmx15mm of the back copper foil, measuring 70mmx70mmx1.6mm.
Pd decreased at 8.8mW/°C for temperatures above Ta=25°C.

Caution: Operating the IC over the absolute maximum ratings may damage the IC. The damage can either be a short circuit between pins or an open circuit between pins and the internal circuitry. Therefore, it is important to consider circuit protection measures, such as adding a fuse, in case the IC is operated over the absolute maximum ratings.

Recommended Operating Conditions (Ta=-40°C to +125°C)

(Please set after considering power consumption for the power-supply voltage.)

Parameter	Symbol	Rating			Unit	Conditions
		Min	Typ	Max		
Power Supply Voltage	V _{IN}	5.5	13	40	V	-
Current Setting Resistor	R _{ISETH}	10	-	100	kΩ	STOP=H
	R _{ISETL}	10	-	100	kΩ	STOP=L
Minimum Capacitor connecting IOOUT terminal	C _{IOOUT}	0.1	-	-	μF	

Electrical Characteristics

(Unless otherwise specified, Ta=-40°C to 125°C, V_{IN}=13V, R_{ISETL}=R_{ISETH}=40kΩ, R_{PBUS}=10kΩ)

Parameter	Symbol	Limit			Unit	Conditions
		Min	Typ	Max		
Circuit Current	I _{VIN}	-	2.9	5	mA	
IOUT Output Current H	I _{OUT_H}	48.5	50	51.5	mA	50mA setting (I _{SET} =40kΩ) STOP=High, Ta=25°C
		46	50	54	mA	50mA setting (I _{SET} =40kΩ) STOP=High, Ta=-40°C to +125°C
IOUT Output Current L	I _{OUT_L}	4.85	5	5.15	mA	5mA setting (I _{SET} =40kΩ) STOP=Low, Ta=25°C
		4.6	5	5.4	mA	5mA setting (I _{SET} =40kΩ) STOP=Low, Ta=-40°C to +125°C
IOUT Drop Voltage H	V _{DRH_IOUT}	-	0.7	1.2	V	200mA setting(I _{SET} =10kΩ) STOP=High
IOUT Drop Voltage L	V _{DRL_IOUT}	-	0.5	0.7	V	20mA setting(I _{SET} =10kΩ) STOP=Low
IOUT OFF Current	I _{IOUT_OFF}	-	-	1	μA	V _{IOUT} =2V, PBUS=L, Ta=25°C
IOUT Current at GND Short	I _{IOUT_SHORT}	-	-	40	μA	V _{IOUT} =0V
ISET Terminal Voltage	V _{ISET}	-	0.8	-	V	At ISETL or ISETH pins
ISET Short Detection Resistor	R _{ISET_SHORT}	-	5.1k	7.5k	Ω	At ISETL or ISETH pins
ISET Open Detection Resistor	R _{ISET_OPEN}	125k	400k	-	Ω	At ISETL or ISETH pins
IOUT LED OPEN Detection	V _{IOUT_OPEN}	V _{IN} -0.3	V _{IN} -0.2	V _{IN} -0.1	V	
IOUT LED Short Detection	V _{IOUT_SHORT}	0.2	0.6	1.0	V	
STOP Input Voltage H	V _{IH_STOP}	4.0	-	V _{IN} +0.2	V	
STOP Input Voltage L	V _{IL_STOP}	GND	-	1.0	V	
STOP Input Current	I _{IN_STOP}	-	40	100	μA	V _{STOP} =13V
PBUS Input Voltage H	V _{IH_PBUS}	4.0	-	V _{IN} +0.2	V	
PBUS Input Voltage L	V _{IL_PBUS}	GND	-	2.0	V	
PBUS Low Voltage	V _{OL_PBUS}	-	-	1.5	V	I _{PBUS} =20mA
PBUS Input Current	I _{IN_PBUS}	-	38	100	μA	V _{PBUS} =13V
IN Under Voltage Open Detection Mask Voltage	V _{UVLO_IOPEN}	7.5	8.0	8.5	V	
Over Voltage Mute Voltage	V _{IN_OVPMUTE}	16	19	24	V	200mA setting (I _{SET} =10kΩ) STOP=High

Typical Performance Curves (Reference Data)

(Unless otherwise specified $T_a=25^\circ\text{C}$, $V_{IN}=13\text{V}$)

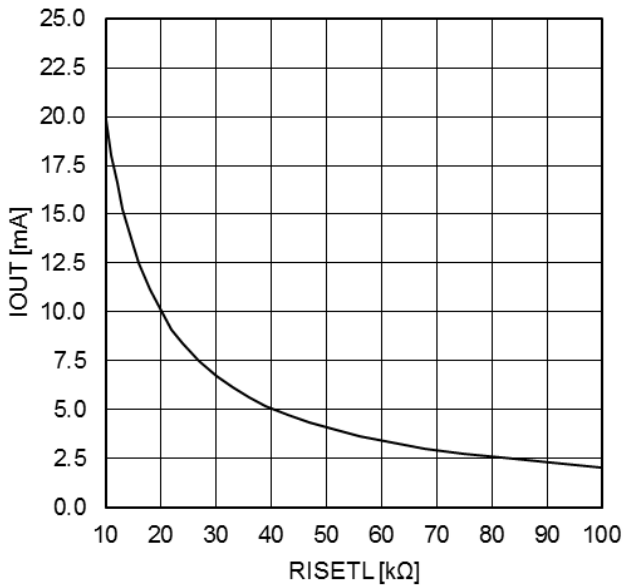

Figure 5. I_{OUT} vs R_{ISETL} (STOP=Low)

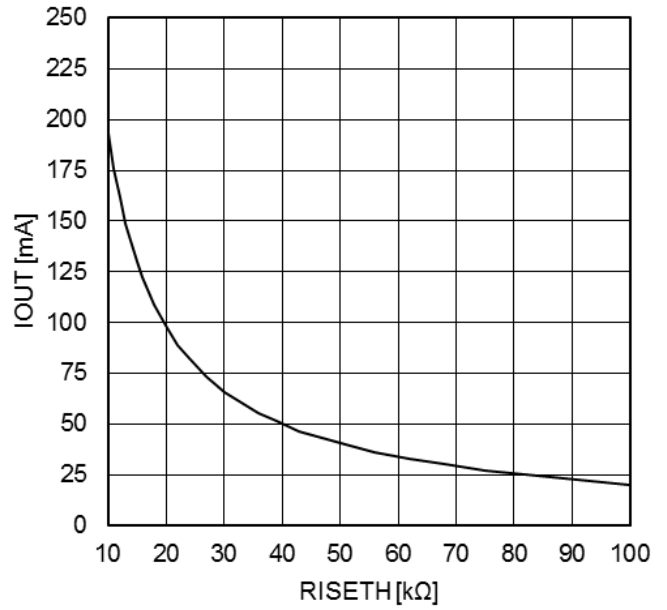

Figure 6. I_{OUT} vs R_{ISETH} (STOP=High)

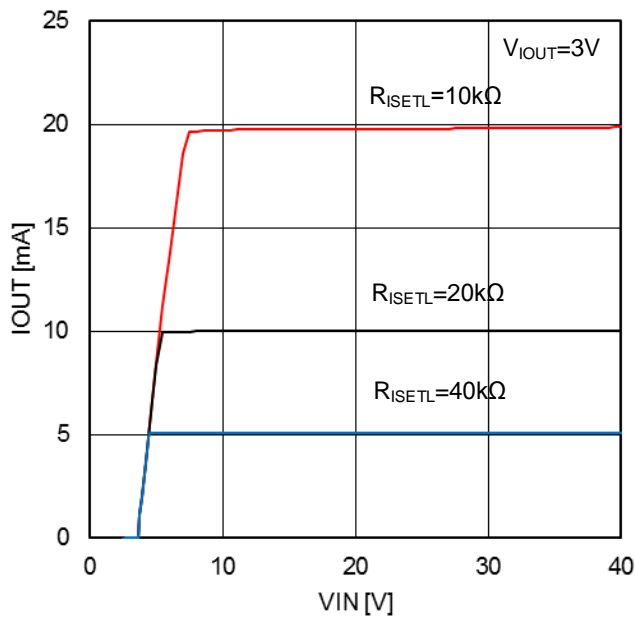

Figure 7. I_{OUT} vs V_{IN} (STOP=Low)

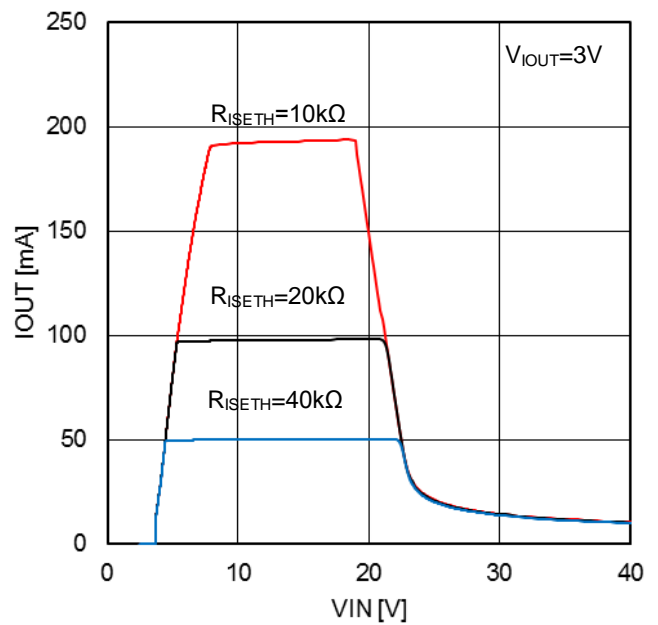

Figure 8. I_{OUT} vs V_{IN} (STOP=High)

Typical Performance Curves (Reference Data) - continued

(Unless otherwise specified $T_a=25^{\circ}\text{C}$, $V_{IN}=13\text{V}$)

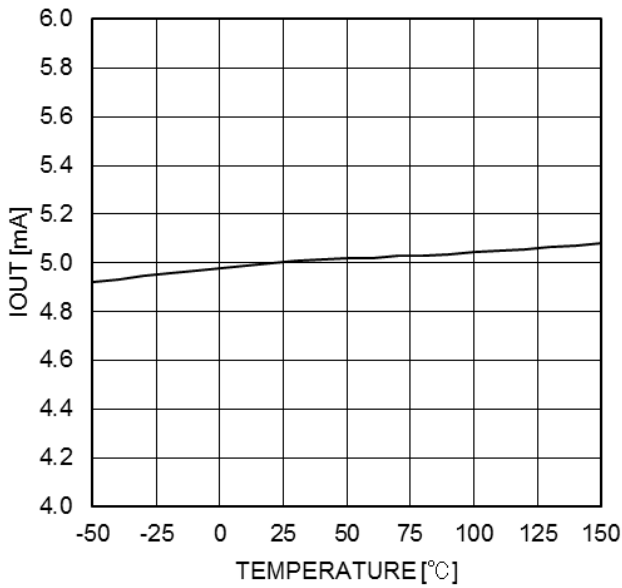

Figure 9. I_{OUT} vs T_a (STOP=Low)

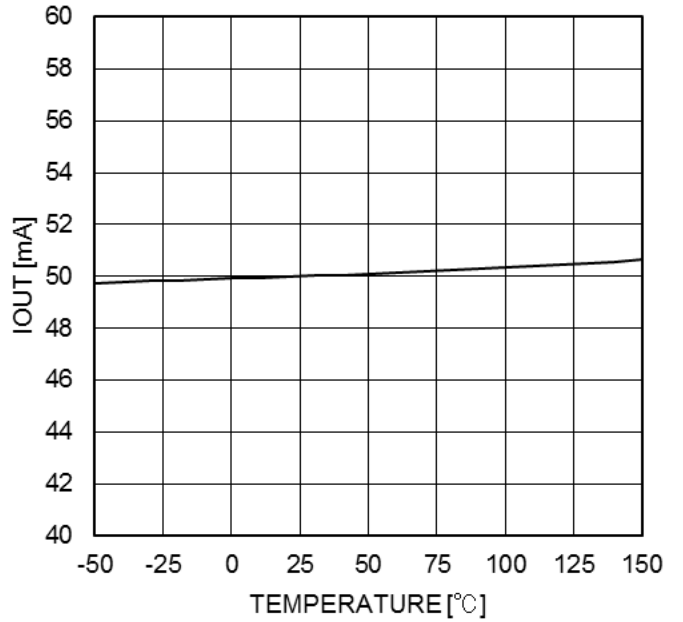

Figure 10. I_{OUT} vs T_a (STOP=High)

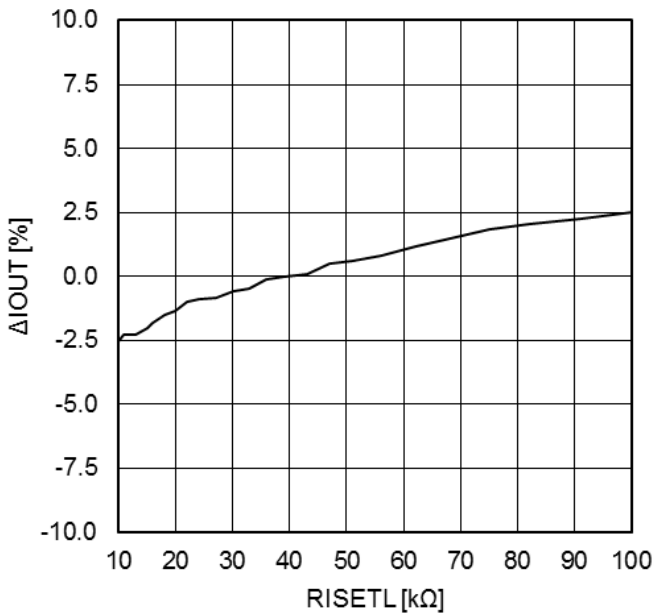

Figure 11. ΔI_{OUT} vs R_{ISETL} (STOP=Low)

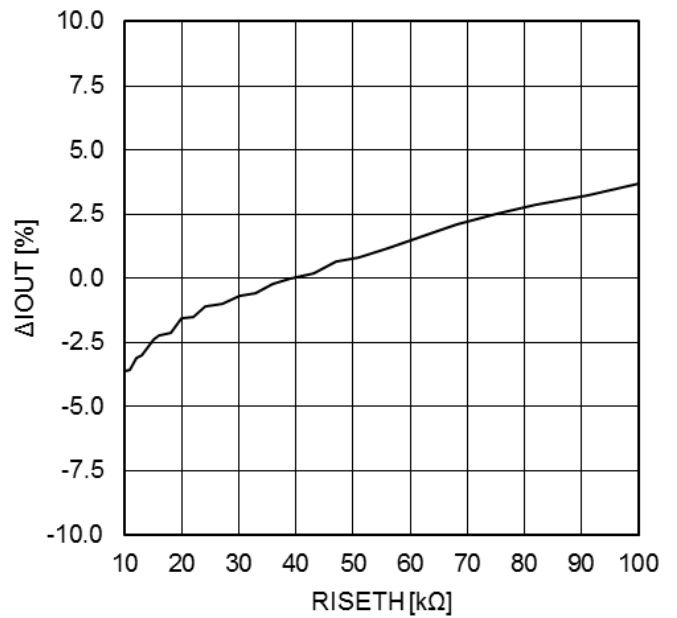

Figure 12. ΔI_{OUT} vs R_{ISETH} (STOP=High)

Timing Chart

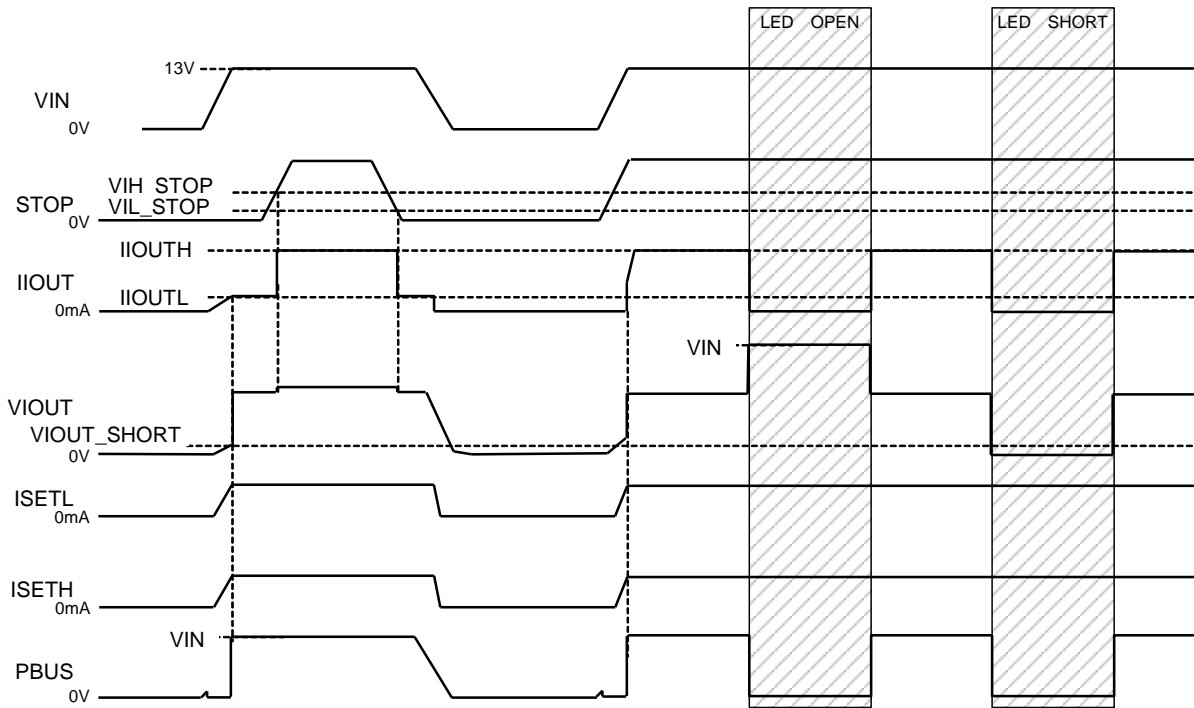
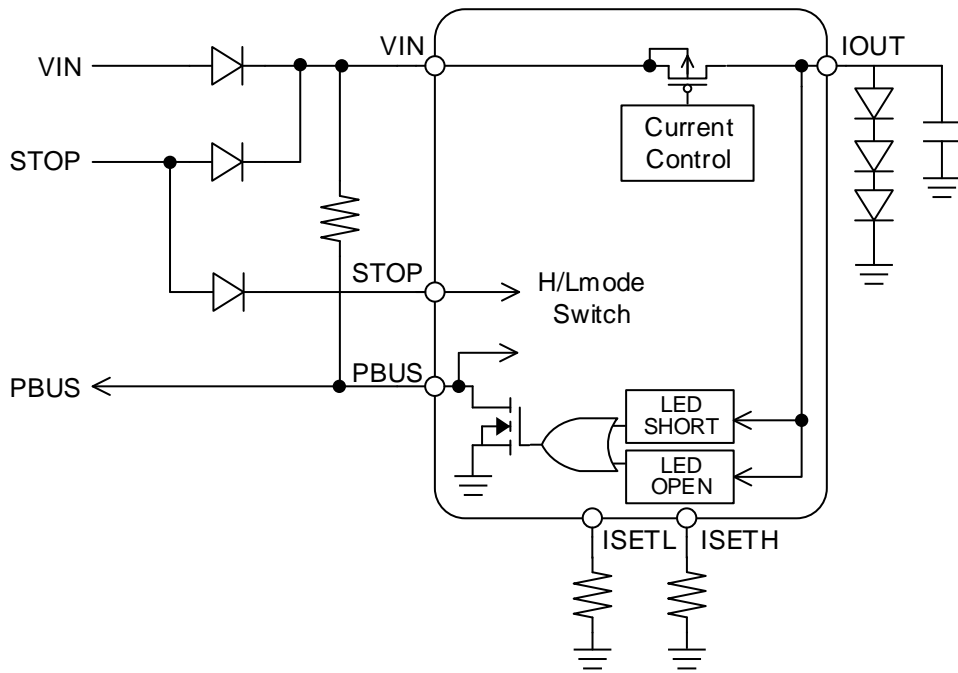

Figure 13. Timing Chart

Function Description

(Unless otherwise specified, $T_a=25^{\circ}\text{C}$, $V_{\text{IN}}=13\text{V}$, $R_{\text{ISETL}}=R_{\text{ISETH}}=40\text{k}\Omega$, the numerical value in the table are TYP values.)

1. Table for Operation

STOP	V_{IOUT}	R_{ISETL}	R_{ISETH}	MODE	I_{OUT}	PBUS
L	$2\text{V} < V_{\text{IOUT}} < V_{\text{IN}} - 0.7\text{V}(\text{Max})$	$10\text{k}\Omega \leq R_{\text{ISETL}} \leq 100\text{k}\Omega$	-	L mode normal operation	2mA to 20mA	Hi-Z
H	$2\text{V} < V_{\text{IOUT}} < V_{\text{IN}} - 1.2\text{V}(\text{Max})$	-	$10\text{k}\Omega \leq R_{\text{ISETH}} \leq 100\text{k}\Omega$	H mode normal operation	20mA to 200mA	Hi-Z
L/H	$V_{\text{IOUT}} \leq 0.6\text{V}(\text{Typ})$	-	-	Output short	40 $\mu\text{A}(\text{Max})$	LOW output
L/H	$V_{\text{IOUT}} \geq V_{\text{IN}} - 0.2\text{V}(\text{Typ})$	-	-	Output open	1 $\mu\text{A}(\text{Max})$	LOW output
L	-	$R_{\text{ISETL}} < 7.5\text{k}\Omega(\text{Max})$	-	I_{SETL} short	1 $\mu\text{A}(\text{Max})$	LOW output
L	-	$R_{\text{ISETL}} > 125\text{k}\Omega(\text{Min})$	-	I_{SETL} open	1 $\mu\text{A}(\text{Max})$	LOW output
H	-	-	$R_{\text{ISETH}} < 7.5\text{k}\Omega(\text{Max})$	I_{SETH} short	1 $\mu\text{A}(\text{Max})$	LOW output
H	-	-	$R_{\text{ISETH}} > 125\text{k}\Omega(\text{Min})$	I_{SETH} open	1 $\mu\text{A}(\text{Max})$	LOW output
L	$2\text{V} < V_{\text{IOUT}} < V_{\text{IN}} - 0.7\text{V}(\text{Max})$	$10\text{k}\Omega \leq R_{\text{ISETL}} \leq 100\text{k}\Omega$	-	PBUS control OFF	1 $\mu\text{A}(\text{Max})$	LOW input
H	$2\text{V} < V_{\text{IOUT}} < V_{\text{IN}} - 1.2\text{V}(\text{Max})$	-	$10\text{k}\Omega \leq R_{\text{ISETH}} \leq 100\text{k}\Omega$	PBUS control OFF	1 $\mu\text{A}(\text{Max})$	LOW input

Protection Mode Operation Voltage(The numerical value are typical)

V_{IN}	LED open	LED short	ISET open	ISET short	PBUS	Oversvoltage protection
$5.5\text{V} < V_{\text{IN}} \leq 8\text{V}$	x	o	o	o	o	x
$8\text{V} \leq V_{\text{IN}} \leq 19\text{V}$	o	o	o	o	o	x
$19\text{V} \leq V_{\text{IN}}$	o	o	o	o	o	o

o : Protection mode ON

x : Protection mode OFF

The LED open function is masked with $V_{\text{IN}} \leq 8\text{V}$.

2. Method of Setting Current

The IC regulates the voltage at ISETL/ISETH to V_{ISET} (0.8V typ) across the external resistor to set I_{OUT} . Then I_{OUT} is set by setting STOP High or Low.

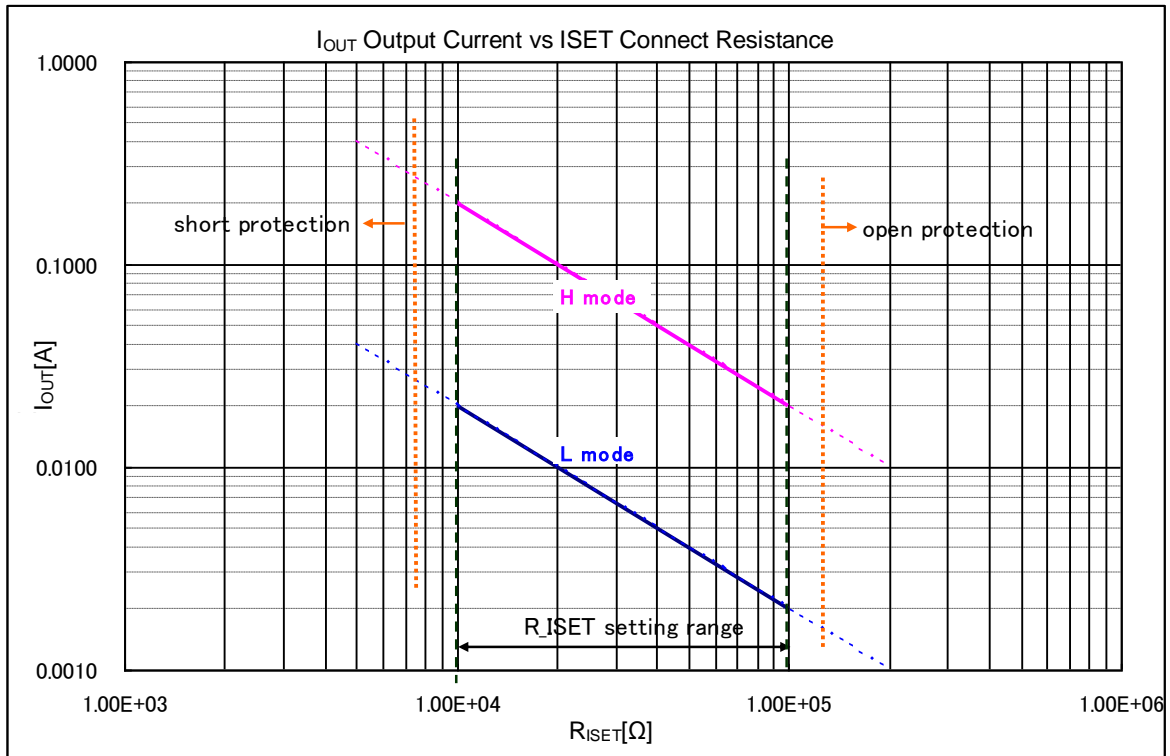
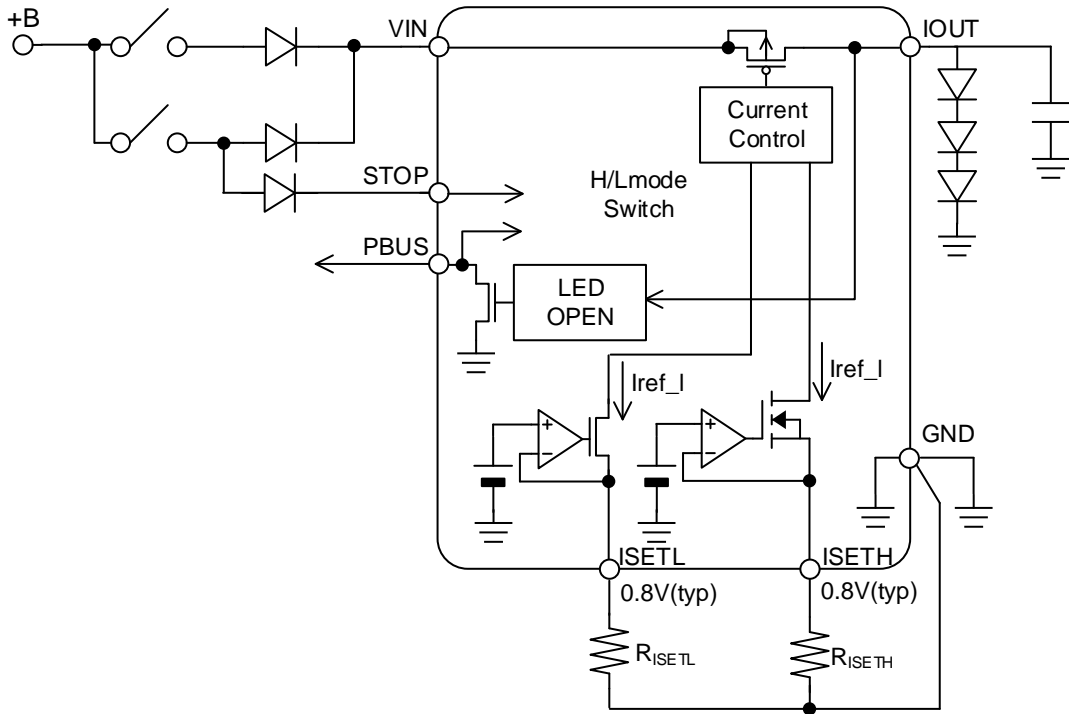

Figure 14. Current setting method

- L mode (STOP=Low)

$$I_{IOUT} = \frac{0.8V}{R_{ISETL}} \times 250A$$

exp) $R_{ISETL} = 40k\Omega$ $I_{IOUT} = \frac{0.8V}{40k\Omega} \times 250 = 5mA$

- H mode (STOP=High)

$$I_{IOUT} = \frac{0.8V}{R_{ISETH}} \times 2500A$$

exp) $R_{ISETH} = 40k\Omega$ $I_{IOUT} = \frac{0.8V}{40k\Omega} \times 2500 = 50mA$

3. Current Control at Output Saturation

When $V_{IOUT} (=V_F) - V_{IN} > 0.5V$ (TYP), the LED current I_F is decreased to a set current $20\mu A$ (TYP). Therefore, V_F decreases due to the decrease in the current. Open detection can be prevented by keeping $V_{IOUT} \leq V_{IN} - 0.5V$. The current controlled to $I_{OUT} < 20\mu A$ and the LED current I_F must be set so that V_F does not exceed V_{UVLO_OPEN} by $20\mu A$. If $V_{IN} < V_{UVLO_OPEN}$ this function is not active.

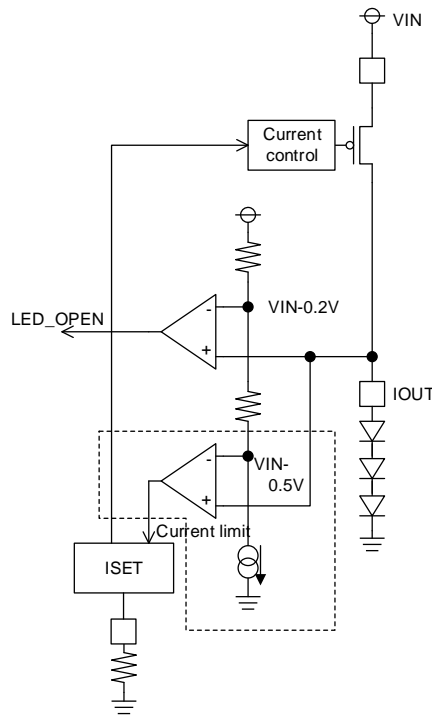
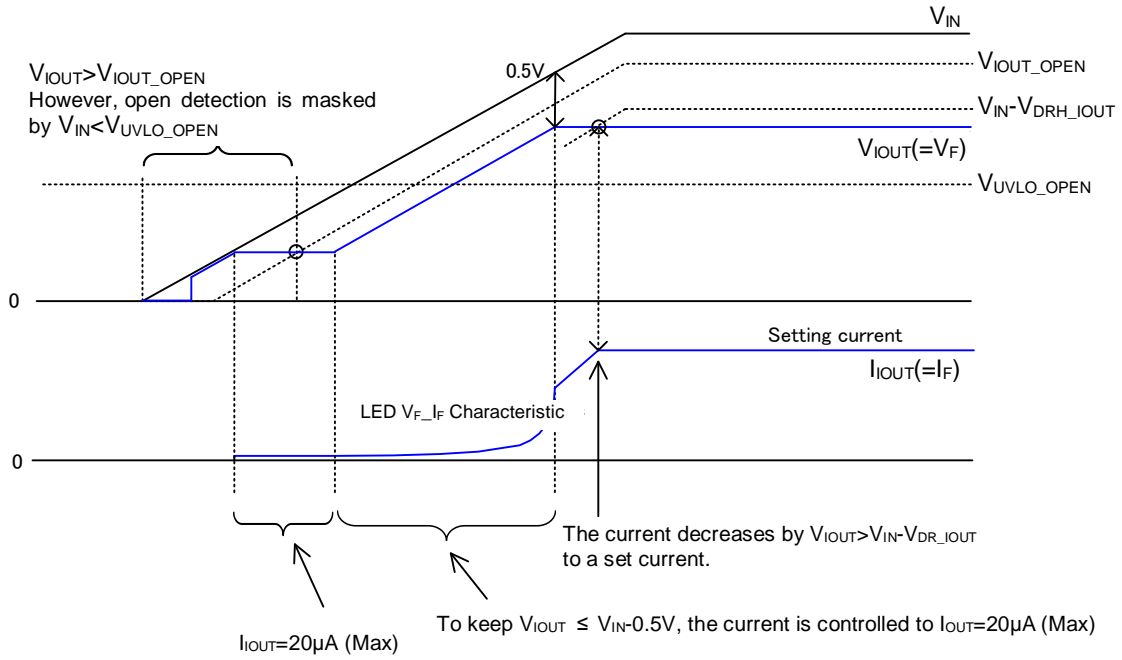

Figure 15. Current Control at Output Saturation

4. PROTECT BUS (PBUS)

PBUS is an I/O terminal that outputs any detected error by switching PBUS from Hi-Z (Note 1) to Low. The output current can also be turned OFF by pulling the PBUS Low. When driving multiple LEDs through multiple ICs, as shown in the figure below, all the rows of LEDs can be turned OFF by any fault by connecting PBUS terminal to each IC.

(Note1) PBUS terminal is an open drain terminal. Even when used separately, please be pulled up(10kΩ) to power supply voltage.

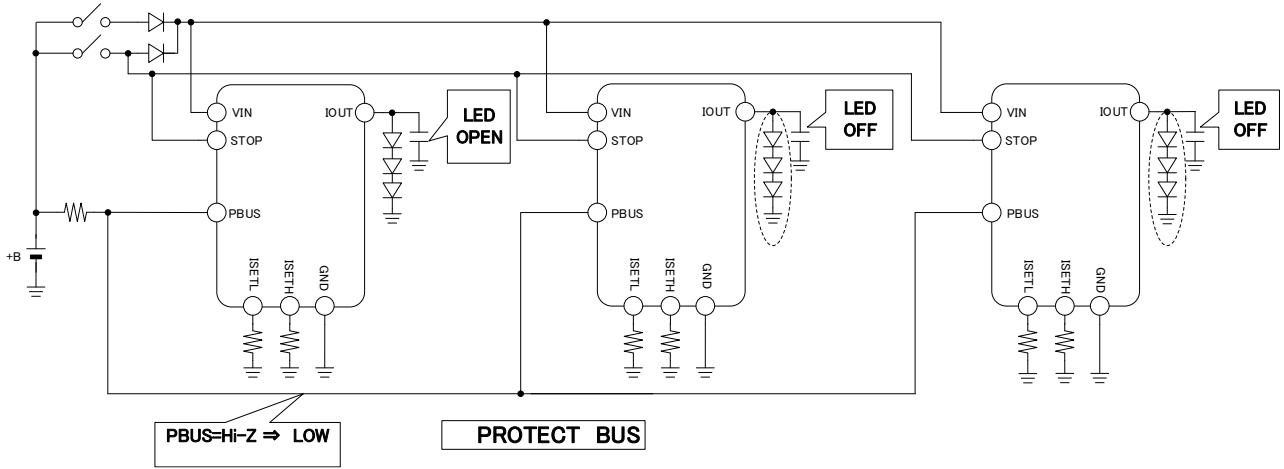

Figure 16. PBUS Function

- Example of operating protection for an LED open condition

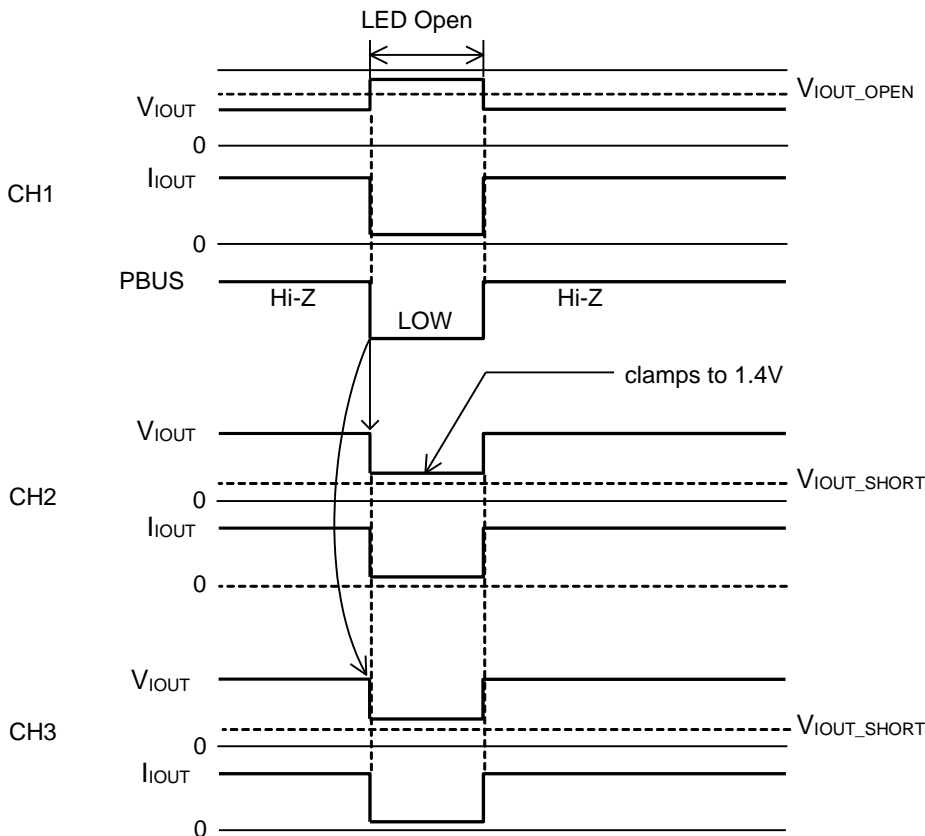

Figure 17. Example of protective Operation

When LED becomes open on the first IC, PBUS of IC1 is switched from Hi-Z to Low. As PBUS becomes Low, the other ICs detect the error and turns OFF their own LEDs. V_{IOUT} clamps to 1.4V during the OFF period in order to prevent ground short protection.

5. Protection Function

This IC has built-in short/open protection function for the external components. Any error detected will pull the PBUS terminal low.

(1) LED Open Detecting Function

When any LED connected at the IOOUT becomes open, V_{IOOUT} will go HIGH. When an error is detected at $V_{IOOUT} < V_{IOOUT_OPEN}$ the PBUS is pulled LOW.

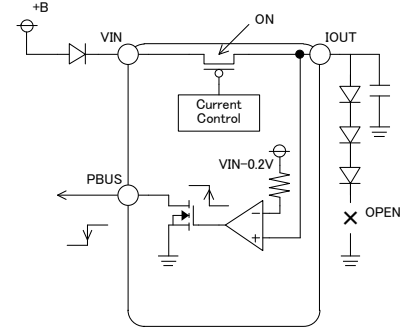

Figure 18. LED Open detection function

(2) LED Short Detecting Function

When the LEDs connected at the IOOUT terminal are shorted to ground, V_{IOOUT} will go LOW. When an error is detected at $V_{IOOUT} < V_{IOOUT_SHORT} 0.6V$ (TYP) the output current is turned OFF to prevent IC heating and the PBUS is pulled LOW.

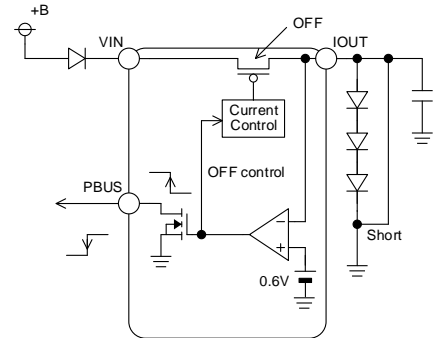

Figure 19. LED Short detection function

(3) ISET(H/L) Open Detection Function

When the external resistance connected to ISET(H/L) terminal is open, ISET(H/L) open detection will be activated by decreasing the ISET(H/L) terminal current. At L mode, ISETL open detection is activated nevertheless state of the ISETH terminal. Also at H mode, ISETH open detection is activated nevertheless state of the ISETL terminal. The output current is turned off While detecting open and it can be notify the abnormally by changing the PBUS terminal output to low.

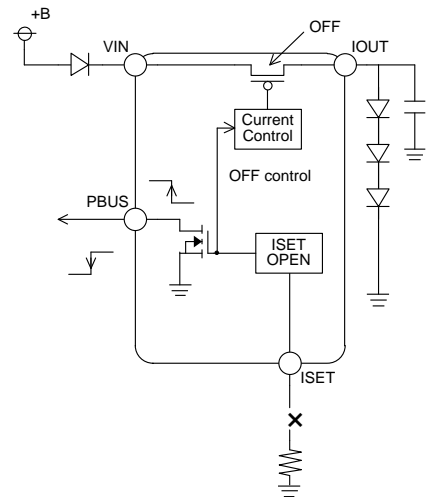

Figure 20. ISET Pin open detection function

(4) ISET(H/L) Short Detection Function

When the external resistance connected to ISET(H/L) terminal is short to GND, ISET(H/L) short detection will be activated by increasing the ISET(H/L) terminal current. At L mode, ISETL short detection is activated nevertheless state of the ISETH terminal. Also at H mode, ISETH short detection is activated nevertheless state of the ISETL terminal. The output current is turned off While detecting short to GND and it can be notify the abnormally by changing the PBUS terminal output to low.

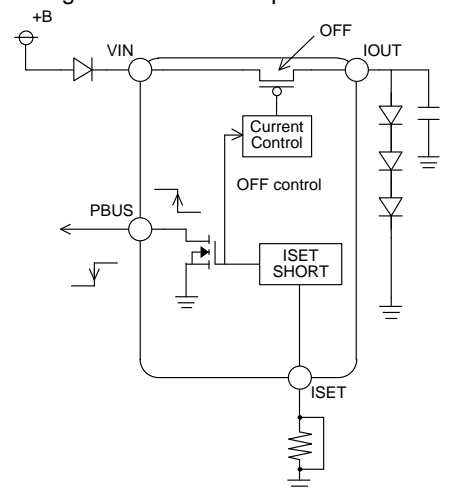

Figure 21. ISET Pin short detection function

6. Over Voltage Protection

Overvoltage protection works in ($R_{\text{SETH}}=40\text{k}\Omega$), $18\text{V (TYP)} \leq V_{\text{IN}}$ at $I_{\text{OUT}}=200\text{mA}$ setting and limits output current to suppress the upswing in heat generation of LSI.
The overvoltage mute protection is effective only for (STOP=High) at H mode time.

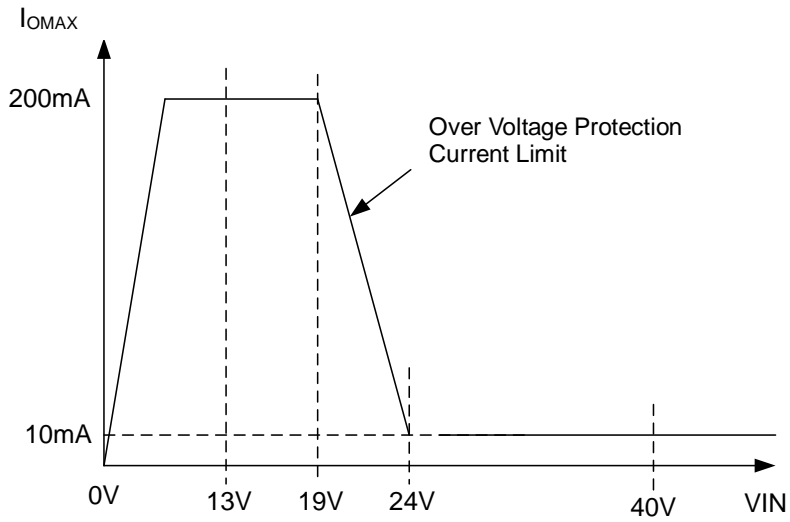

Figure 22. Overvoltage mute function

Recommended application circuit

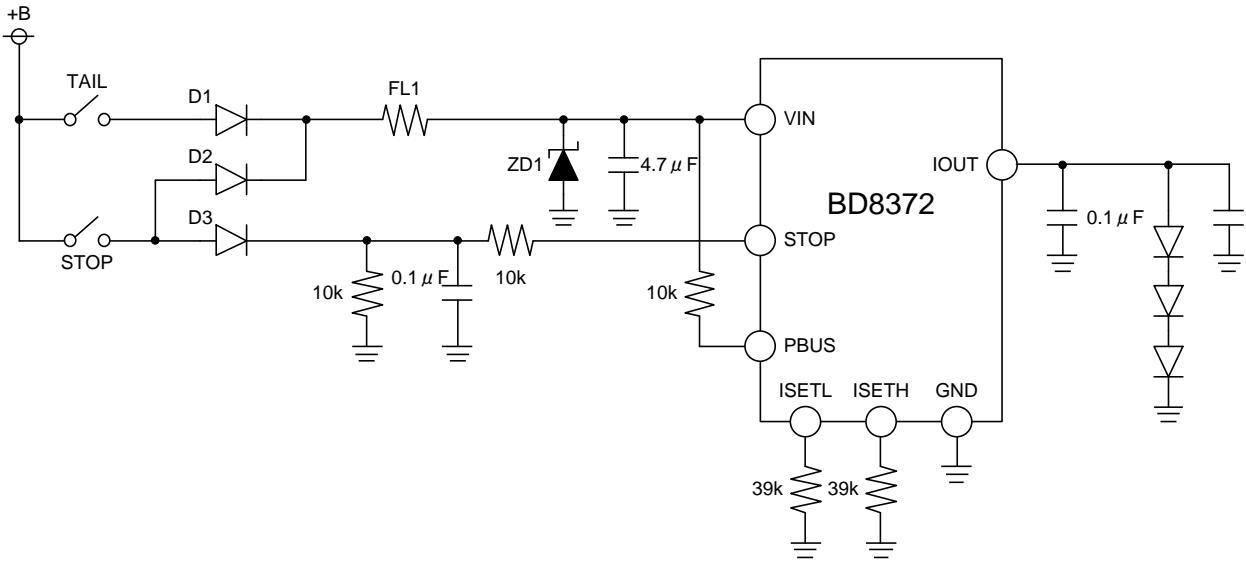

Figure 23. Recommended application circuit

(Note) EMC

ISO 11452-2 (ALSE)

ISO 11452-4 (BCI)

ISO 7637-2

- pulse1
- Pulse2a,2b (level4)
- Pulse3a,3b (level4)

No.	Component Name	Component Value	Product Name	Company
1	D1	-	RF201L2S	ROHM
2	D2	-	RF201L2S	ROHM
3	D3	-	RF201L2S	ROHM
4	Z _{D1}	-	TNR12H-220K	NIPPON CHEMICON
5	FL1	-	MMZ2012R102A	TDK
6	C _{VIN}	4.7μF	GCM32ER71H475KA40	murata
7	C _{IOUT}	0.1μF	GCM188R11H104KA42	murata
8	C _{STOP}	0.1μF	GCM188R11H104KA42	murata
9	R _{ISETL}	39kΩ	MCR03 Series	ROHM
10	R _{ISETH}	39kΩ	MCR03 Series	ROHM
11	R _{PBUS}	10kΩ	MCR03 Series	ROHM
12	R1	10kΩ	MCR03 Series	ROHM
13	R2	10kΩ	MCR03 Series	ROHM

Table 1. BOM List

Power Dissipation

HRP7 Package

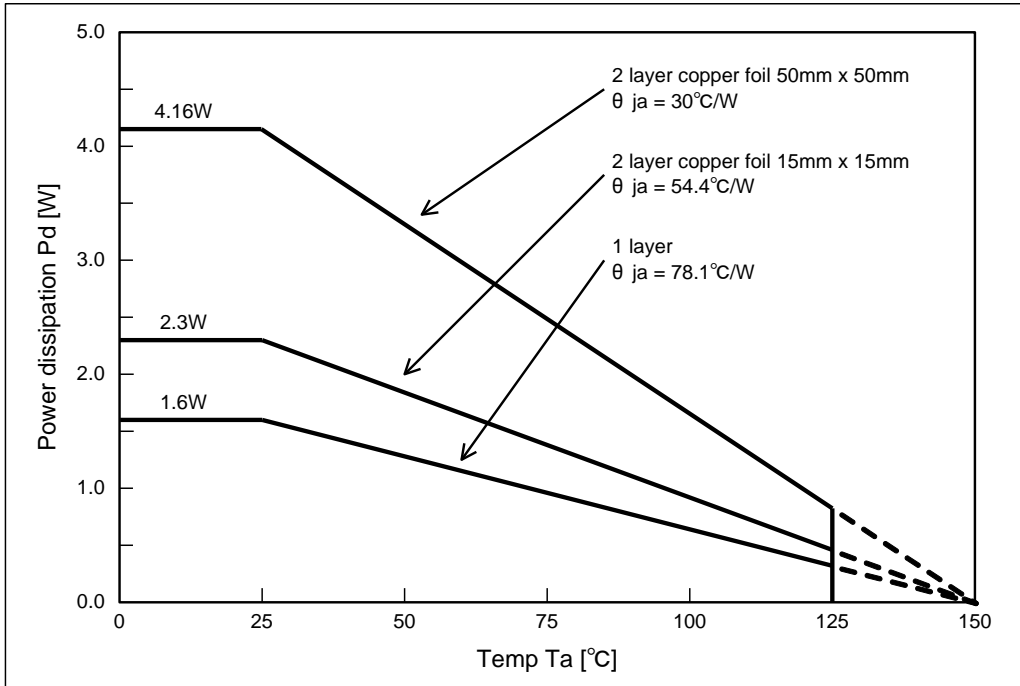

HTSOP-J8 Package

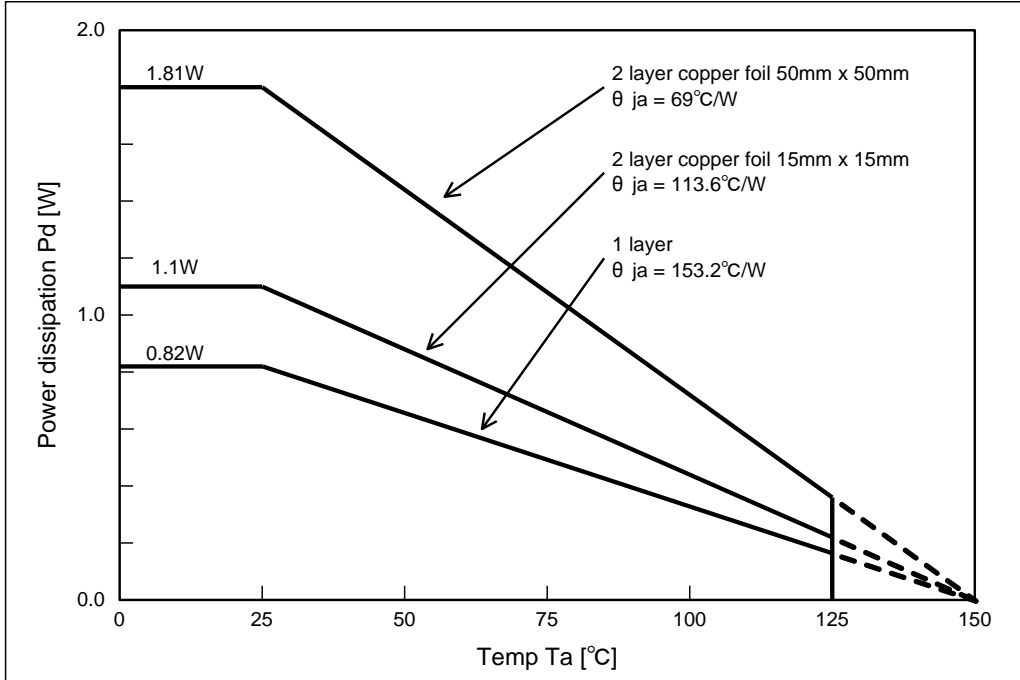

- (Caution1) When mounted with 70.0mm x 70.0mm x 1.6mm glass epoxy substrate.
- (Caution2) Above copper foil area indicates backside copper foil area.
- (Caution3) Value changes according to number of substrate layers and copper foil area. Note that this value is a measured value. Not a guaranteed value.

Figure 24. Thermal Dissipation Curve

Pd (Power dissipation) and I_{OMAX} (Permissible current)

The relation between Pd and I_{OMAX} by V_F of LED connected with IO_{UT} is shown.

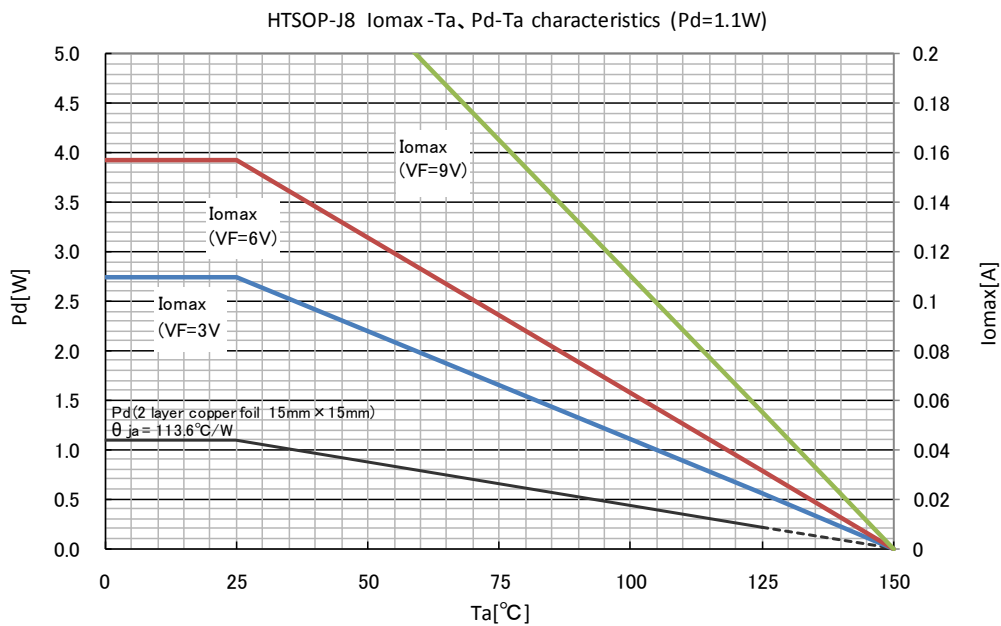
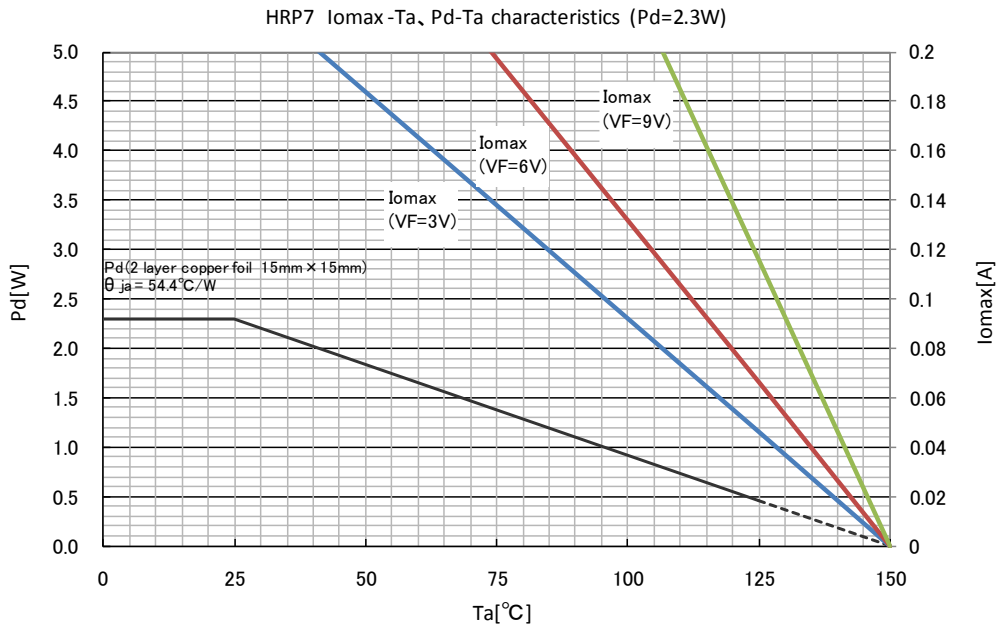
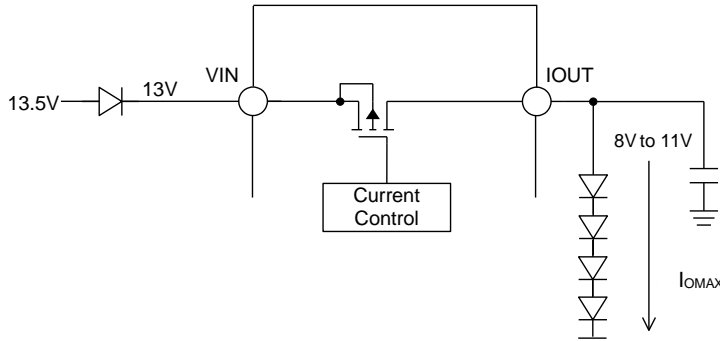
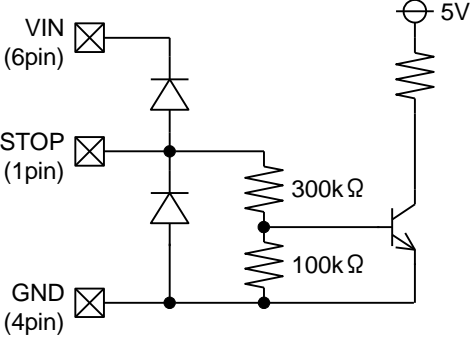
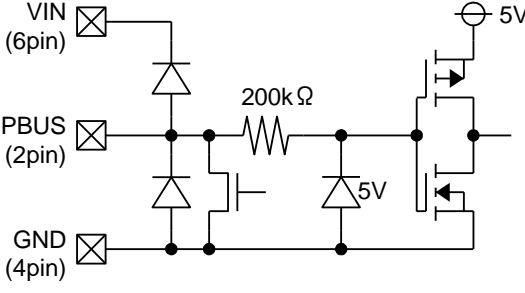
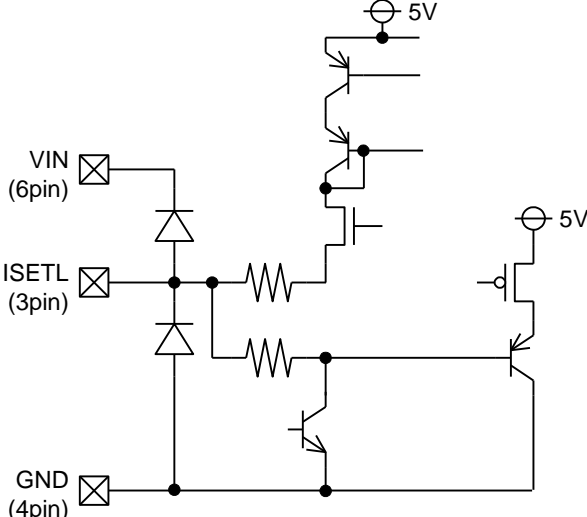

Figure 25. Heat reduction curve

I/O Equivalent Circuit (HRP7 Package)

Pin No.	Pin Name	I/O Equivalent Circuit
1	STOP	
2	PBUS	
3	ISETL	
4	GND	-

I/O Equivalent Circuit (HRP7 Package)– continued

Pin No.	Pin Name	I/O Equivalent Circuit
5	ISETH	
6	VIN	-
7	IOUT	

Operational Notes

- 1. Reverse Connection of Power Supply**

Connecting the power supply in reverse polarity can damage the IC. Take precautions against reverse polarity when connecting the power supply, such as mounting an external diode between the power supply and the IC's power supply pins.
- 2. Power Supply Lines**

Design the PCB layout pattern to provide low impedance supply lines. Separate the ground and supply lines of the digital and analog blocks to prevent noise in the ground and supply lines of the digital block from affecting the analog block. Furthermore, connect a capacitor to ground at all power supply pins. Consider the effect of temperature and aging on the capacitance value when using electrolytic capacitors.
- 3. Ground Voltage**

Ensure that no pins are at a voltage below that of the ground pin at any time, even during transient condition.
- 4. Ground Wiring Pattern**

When using both small-signal and large-current ground traces, the two ground traces should be routed separately but connected to a single ground at the reference point of the application board to avoid fluctuations in the small-signal ground caused by large currents. Also ensure that the ground traces of external components do not cause variations on the ground voltage. The ground lines must be as short and thick as possible to reduce line impedance.
- 5. Thermal Consideration**

Should by any chance the power dissipation rating be exceeded the rise in temperature of the chip may result in deterioration of the properties of the chip. In case of exceeding this absolute maximum rating, increase the board size and copper area to prevent exceeding the Pd rating.
- 6. Recommended Operating Conditions**

These conditions represent a range within which the expected characteristics of the IC can be approximately obtained. The electrical characteristics are guaranteed under the conditions of each parameter.
- 7. Inrush Current**

When power is first supplied to the IC, it is possible that the internal logic may be unstable and inrush current may flow instantaneously due to the internal powering sequence and delays, especially if the IC has more than one power supply. Therefore, give special consideration to power coupling capacitance, power wiring, width of ground wiring, and routing of connections.
- 8. Operation Under Strong Electromagnetic Field**

Operating the IC in the presence of a strong electromagnetic field may cause the IC to malfunction.
- 9. Testing on Application Boards**

When testing the IC on an application board, connecting a capacitor directly to a low-impedance output pin may subject the IC to stress. Always discharge capacitors completely after each process or step. The IC's power supply should always be turned off completely before connecting or removing it from the test setup during the inspection process. To prevent damage from static discharge, ground the IC during assembly and use similar precautions during transport and storage.
- 10. Inter-pin Short and Mounting Errors**

Ensure that the direction and position are correct when mounting the IC on the PCB. Incorrect mounting may result in damaging the IC. Avoid nearby pins being shorted to each other especially to ground, power supply and output pin. Inter-pin shorts could be due to many reasons such as metal particles, water droplets (in very humid environment) and unintentional solder bridge deposited in between pins during assembly to name a few.

Operational Notes – continued

11. **Unused Input Pins**

Input pins of an IC are often connected to the gate of a MOS transistor. The gate has extremely high impedance and extremely low capacitance. If left unconnected, the electric field from the outside can easily charge it. The small charge acquired in this way is enough to produce a significant effect on the conduction through the transistor and cause unexpected operation of the IC. So unless otherwise specified, unused input pins should be connected to the power supply or ground line.

12. **Regarding the Input Pin of the IC**

This monolithic IC contains P+ isolation and P substrate layers between adjacent elements in order to keep them isolated. P-N junctions are formed at the intersection of the P layers with the N layers of other elements, creating a parasitic diode or transistor. For example (refer to figure below):

When $GND > Pin A$ and $GND > Pin B$, the P-N junction operates as a parasitic diode.
 When $GND > Pin B$, the P-N junction operates as a parasitic transistor.

Parasitic diodes inevitably occur in the structure of the IC. The operation of parasitic diodes can result in mutual interference among circuits, operational faults, or physical damage. Therefore, conditions that cause these diodes to operate, such as applying a voltage lower than the GND voltage to an input pin (and thus to the P substrate) should be avoided.

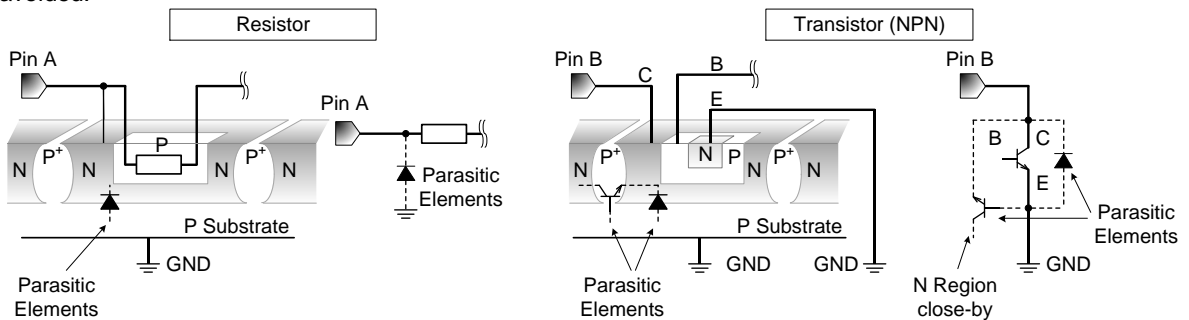

Figure 26. Example of monolithic IC structure

13. **Thermal Shutdown Circuit(TSD)**

This IC has a built-in thermal shutdown circuit that prevents heat damage to the IC. Normal operation should always be within the IC's power dissipation rating. If however the rating is exceeded for a continued period, the junction temperature (T_j) will rise which will activate the TSD circuit that will turn OFF all output pins. When the T_j falls below the TSD threshold, the circuits are automatically restored to normal operation.

Note that the TSD circuit operates in a situation that exceeds the absolute maximum ratings and therefore, under no circumstances, should the TSD circuit be used in a set design or for any purpose other than protecting the IC from heat damage.

14. **Sudden Voltage Surge on V_{IN}**

Because MOSFETs are used in the output, a very steep change in the VCC voltage may cause the transistors to conduct large current. Take this condition into account when selecting the value of external circuit constants for a certain application.

Ordering Information

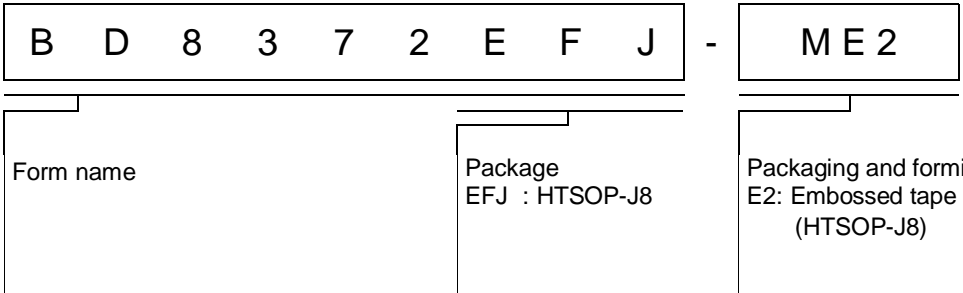
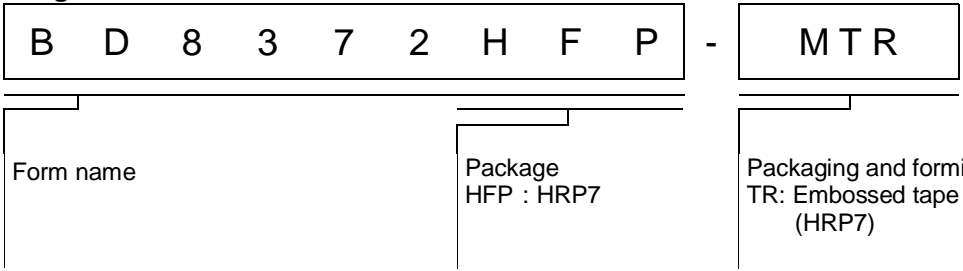

Marking Diagrams

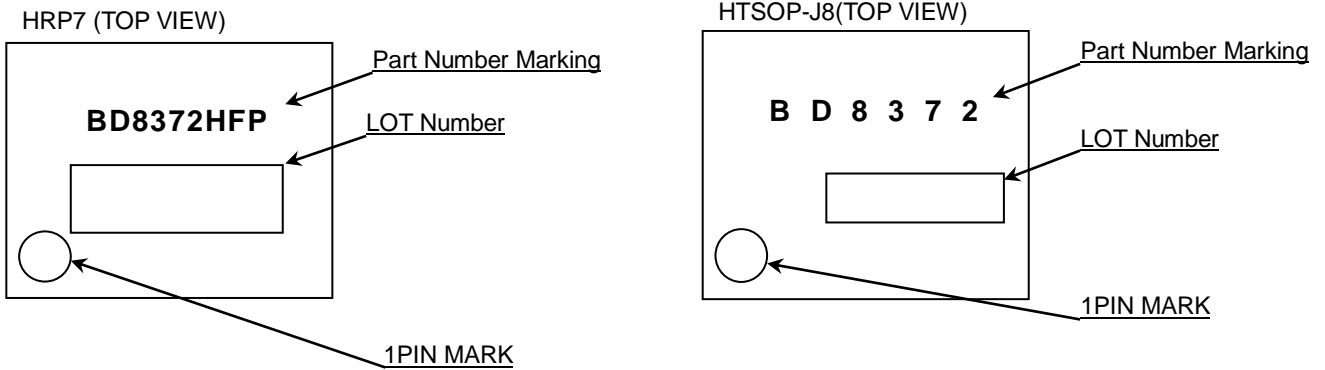

Part Number Marking	Package		Part Number
BD8372HFP	HRP7	Reel of 2000	BD8372HFP-MTR
BD8372	HTSOP-J8	Reel of 2500	BD8372EFJ-ME2

Physical Dimension, Tape and Reel Information

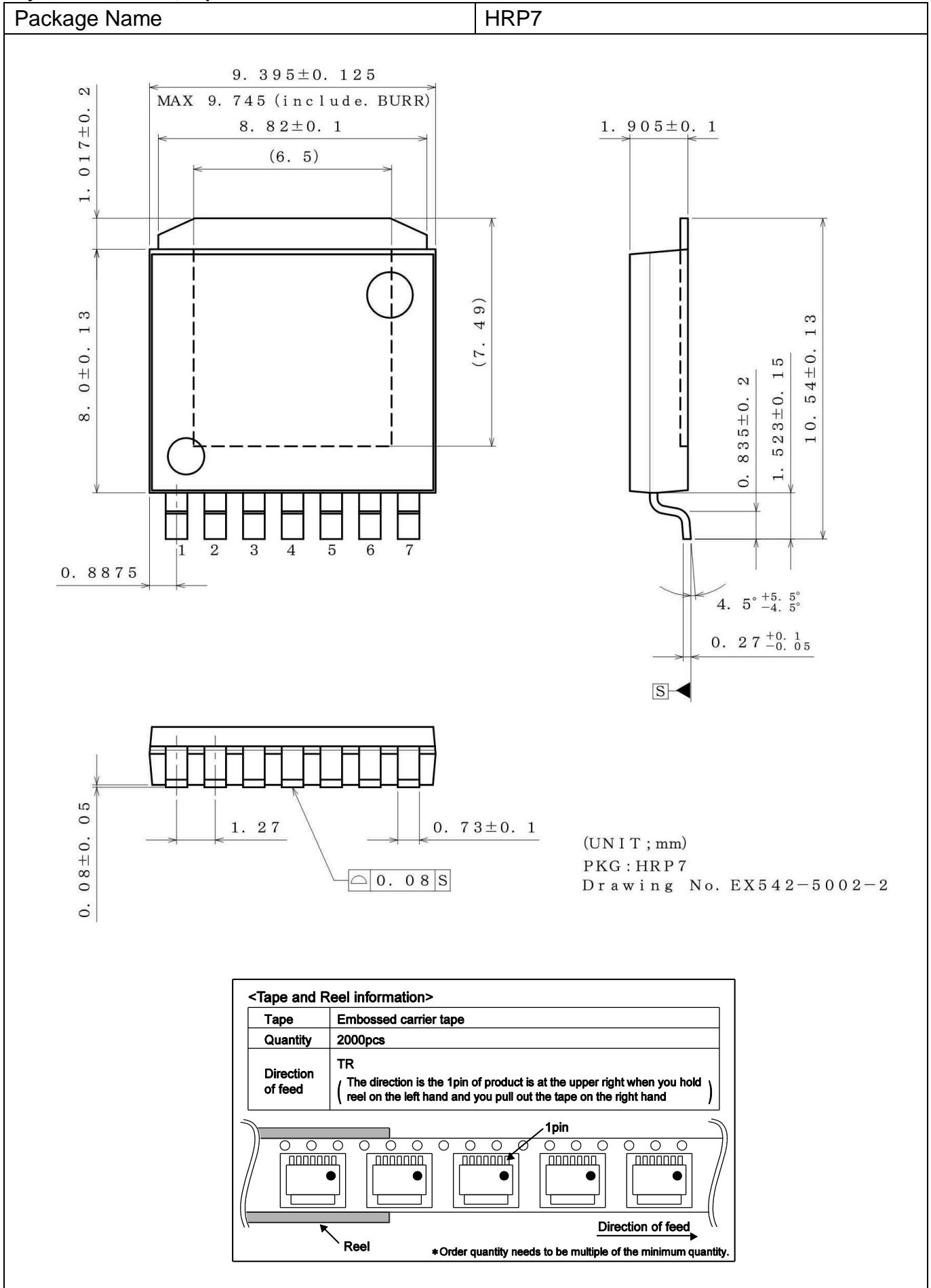

Physical Dimension, Tape and Reel Information – continued

Package Name	HTSOP-J8
--------------	----------

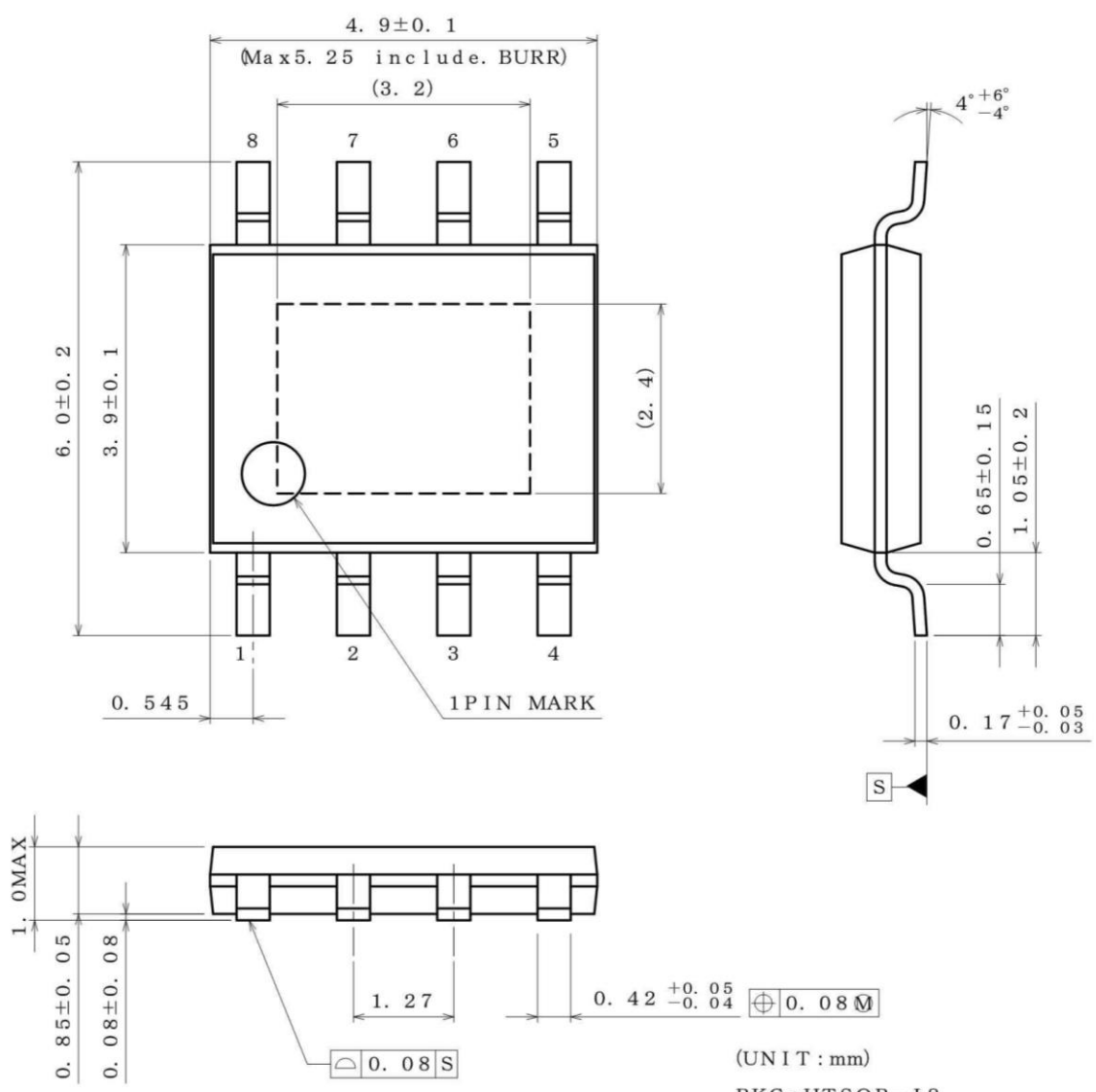

(UNIT : mm)
 PKG : HTSOP-J8
 Drawing No. EX169-5002-2

<Tape and Reel information>

Tape	Embossed carrier tape
Quantity	2500pcs
Direction of feed	E2 (The direction is the 1pin of product is at the upper left when you hold reel on the left hand and you pull out the tape on the right hand)

Reel → Direction of feed →

1pin

*Order quantity needs to be multiple of the minimum quantity.

Revision History

Date	Revision	Changes
06.Nov.2015	001	New Release
		Page. 5 Circuit Current Symbol $I_{IN} \Rightarrow I_{VIN}$ STOP Input Current Symbol $V_{IN_STOP} \Rightarrow I_{IN_STOP}$ IN Over Voltage Current \Rightarrow Over Voltage Mute Voltage
		Page. 8 Figure 13. Timming chart modify
		Page. 10 exp) $R_{ISETL} = 16k\Omega \Rightarrow$ exp) $R_{ISETL} = 40k\Omega$
		Page. 11 Figure 15. $V_{ULOO_OPEN} \Rightarrow V_{UVLO_OPEN}$ $V_{DRH_IOUT} \Rightarrow V_{DRH_IOUT}$
09.Oct.2018	002	Page.13 Figure 18. 20. 21. modify 5. Protection Function PUBS \Rightarrow PBUS (3)ISET(H/L) Open Detection Function change words (4)ISET(H/L) Short Detection Function change words
		Page.15 Figure 23. $2.5k\Omega@100MHz$ delete comment Table 1. BOM List 5 FL1 HMZ2012R102A \Rightarrow MMZ2012R102A
		Page.18 I/O Equivalent Circuit add word (HRP7 Package) 2 PBUS (28pin) \Rightarrow (2pin)

Notice

Precaution on using ROHM Products

1. If you intend to use our Products in devices requiring extremely high reliability (such as medical equipment ^(Note 1), aircraft/spacecraft, nuclear power controllers, etc.) and whose malfunction or failure may cause loss of human life, bodily injury or serious damage to property ("Specific Applications"), please consult with the ROHM sales representative in advance. Unless otherwise agreed in writing by ROHM in advance, ROHM shall not be in any way responsible or liable for any damages, expenses or losses incurred by you or third parties arising from the use of any ROHM's Products for Specific Applications.

(Note1) Medical Equipment Classification of the Specific Applications

JAPAN	USA	EU	CHINA
CLASS III	CLASS III	CLASS II b	CLASS III
CLASS IV		CLASS III	

2. ROHM designs and manufactures its Products subject to strict quality control system. However, semiconductor products can fail or malfunction at a certain rate. Please be sure to implement, at your own responsibilities, adequate safety measures including but not limited to fail-safe design against the physical injury, damage to any property, which a failure or malfunction of our Products may cause. The following are examples of safety measures:
 - [a] Installation of protection circuits or other protective devices to improve system safety
 - [b] Installation of redundant circuits to reduce the impact of single or multiple circuit failure
3. Our Products are not designed under any special or extraordinary environments or conditions, as exemplified below. Accordingly, ROHM shall not be in any way responsible or liable for any damages, expenses or losses arising from the use of any ROHM's Products under any special or extraordinary environments or conditions. If you intend to use our Products under any special or extraordinary environments or conditions (as exemplified below), your independent verification and confirmation of product performance, reliability, etc. prior to use, must be necessary:
 - [a] Use of our Products in any types of liquid, including water, oils, chemicals, and organic solvents
 - [b] Use of our Products outdoors or in places where the Products are exposed to direct sunlight or dust
 - [c] Use of our Products in places where the Products are exposed to sea wind or corrosive gases, including Cl₂, H₂S, NH₃, SO₂, and NO₂
 - [d] Use of our Products in places where the Products are exposed to static electricity or electromagnetic waves
 - [e] Use of our Products in proximity to heat-producing components, plastic cords, or other flammable items
 - [f] Sealing or coating our Products with resin or other coating materials
 - [g] Use of our Products without cleaning residue of flux (even if you use no-clean type fluxes, cleaning residue of flux is recommended); or Washing our Products by using water or water-soluble cleaning agents for cleaning residue after soldering
 - [h] Use of the Products in places subject to dew condensation
4. The Products are not subject to radiation-proof design.
5. Please verify and confirm characteristics of the final or mounted products in using the Products.
6. In particular, if a transient load (a large amount of load applied in a short period of time, such as pulse. is applied, confirmation of performance characteristics after on-board mounting is strongly recommended. Avoid applying power exceeding normal rated power; exceeding the power rating under steady-state loading condition may negatively affect product performance and reliability.
7. De-rate Power Dissipation depending on ambient temperature. When used in sealed area, confirm that it is the use in the range that does not exceed the maximum junction temperature.
8. Confirm that operation temperature is within the specified range described in the product specification.
9. ROHM shall not be in any way responsible or liable for failure induced under deviant condition from what is defined in this document.

Precaution for Mounting / Circuit board design

1. When a highly active halogenous (chlorine, bromine, etc.) flux is used, the residue of flux may negatively affect product performance and reliability.
2. In principle, the reflow soldering method must be used on a surface-mount products, the flow soldering method must be used on a through hole mount products. If the flow soldering method is preferred on a surface-mount products, please consult with the ROHM representative in advance.

For details, please refer to ROHM Mounting specification

Precautions Regarding Application Examples and External Circuits

1. If change is made to the constant of an external circuit, please allow a sufficient margin considering variations of the characteristics of the Products and external components, including transient characteristics, as well as static characteristics.
2. You agree that application notes, reference designs, and associated data and information contained in this document are presented only as guidance for Products use. Therefore, in case you use such information, you are solely responsible for it and you must exercise your own independent verification and judgment in the use of such information contained in this document. ROHM shall not be in any way responsible or liable for any damages, expenses or losses incurred by you or third parties arising from the use of such information.

Precaution for Electrostatic

This Product is electrostatic sensitive product, which may be damaged due to electrostatic discharge. Please take proper caution in your manufacturing process and storage so that voltage exceeding the Products maximum rating will not be applied to Products. Please take special care under dry condition (e.g. Grounding of human body / equipment / solder iron, isolation from charged objects, setting of Ionizer, friction prevention and temperature / humidity control).

Precaution for Storage / Transportation

1. Product performance and soldered connections may deteriorate if the Products are stored in the places where:
 - [a] the Products are exposed to sea winds or corrosive gases, including Cl₂, H₂S, NH₃, SO₂, and NO₂
 - [b] the temperature or humidity exceeds those recommended by ROHM
 - [c] the Products are exposed to direct sunshine or condensation
 - [d] the Products are exposed to high Electrostatic
2. Even under ROHM recommended storage condition, solderability of products out of recommended storage time period may be degraded. It is strongly recommended to confirm solderability before using Products of which storage time is exceeding the recommended storage time period.
3. Store / transport cartons in the correct direction, which is indicated on a carton with a symbol. Otherwise bent leads may occur due to excessive stress applied when dropping of a carton.
4. Use Products within the specified time after opening a humidity barrier bag. Baking is required before using Products of which storage time is exceeding the recommended storage time period.

Precaution for Product Label

A two-dimensional barcode printed on ROHM Products label is for ROHM's internal use only.

Precaution for Disposition

When disposing Products please dispose them properly using an authorized industry waste company.

Precaution for Foreign Exchange and Foreign Trade act

Since concerned goods might be fallen under listed items of export control prescribed by Foreign exchange and Foreign trade act, please consult with ROHM in case of export.

Precaution Regarding Intellectual Property Rights

1. All information and data including but not limited to application example contained in this document is for reference only. ROHM does not warrant that foregoing information or data will not infringe any intellectual property rights or any other rights of any third party regarding such information or data.
2. ROHM shall not have any obligations where the claims, actions or demands arising from the combination of the Products with other articles such as components, circuits, systems or external equipment (including software).
3. No license, expressly or implied, is granted hereby under any intellectual property rights or other rights of ROHM or any third parties with respect to the Products or the information contained in this document. Provided, however, that ROHM will not assert its intellectual property rights or other rights against you or your customers to the extent necessary to manufacture or sell products containing the Products, subject to the terms and conditions herein.

Other Precaution

1. This document may not be reprinted or reproduced, in whole or in part, without prior written consent of ROHM.
2. The Products may not be disassembled, converted, modified, reproduced or otherwise changed without prior written consent of ROHM.
3. In no event shall you use in any way whatsoever the Products and the related technical information contained in the Products or this document for any military purposes, including but not limited to, the development of mass-destruction weapons.
4. The proper names of companies or products described in this document are trademarks or registered trademarks of ROHM, its affiliated companies or third parties.

General Precaution

1. Before you use our Products, you are requested to carefully read this document and fully understand its contents. ROHM shall not be in any way responsible or liable for failure, malfunction or accident arising from the use of any ROHM's Products against warning, caution or note contained in this document.
2. All information contained in this document is current as of the issuing date and subject to change without any prior notice. Before purchasing or using ROHM's Products, please confirm the latest information with a ROHM sales representative.
3. The information contained in this document is provided on an "as is" basis and ROHM does not warrant that all information contained in this document is accurate and/or error-free. ROHM shall not be in any way responsible or liable for any damages, expenses or losses incurred by you or third parties resulting from inaccuracy or errors of or concerning such information.

Mouser Electronics

Authorized Distributor

Click to View Pricing, Inventory, Delivery & Lifecycle Information:

[ROHM Semiconductor:](#)

[BD8372EFJ-ME2](#) [BD8372HFP-MTR](#)

Компания «Океан Электроники» предлагает заключение долгосрочных отношений при поставках импортных электронных компонентов на взаимовыгодных условиях!

Наши преимущества:

- Поставка оригинальных импортных электронных компонентов напрямую с производств Америки, Европы и Азии, а так же с крупнейших складов мира;
- Широкая линейка поставок активных и пассивных импортных электронных компонентов (более 30 млн. наименований);
- Поставка сложных, дефицитных, либо снятых с производства позиций;
- Оперативные сроки поставки под заказ (от 5 рабочих дней);
- Экспресс доставка в любую точку России;
- Помощь Конструкторского Отдела и консультации квалифицированных инженеров;
- Техническая поддержка проекта, помощь в подборе аналогов, поставка прототипов;
- Поставка электронных компонентов под контролем ВП;
- Система менеджмента качества сертифицирована по Международному стандарту ISO 9001;
- При необходимости вся продукция военного и аэрокосмического назначения проходит испытания и сертификацию в лаборатории (по согласованию с заказчиком);
- Поставка специализированных компонентов военного и аэрокосмического уровня качества (Xilinx, Altera, Analog Devices, Intersil, Interpoint, Microsemi, Actel, Aeroflex, Peregrine, VPT, Syfer, Eurofarad, Texas Instruments, MS Kennedy, Miteq, Cobham, E2V, MA-COM, Hittite, Mini-Circuits, General Dynamics и др.);

Компания «Океан Электроники» является официальным дистрибьютором и эксклюзивным представителем в России одного из крупнейших производителей разъемов военного и аэрокосмического назначения «JONHON», а так же официальным дистрибьютором и эксклюзивным представителем в России производителя высокотехнологичных и надежных решений для передачи СВЧ сигналов «FORSTAR».



JONHON

«JONHON» (основан в 1970 г.)

Разъемы специального, военного и аэрокосмического назначения:

(Применяются в военной, авиационной, аэрокосмической, морской, железнодорожной, горно- и нефтедобывающей отраслях промышленности)

«FORSTAR» (основан в 1998 г.)

ВЧ соединители, коаксиальные кабели, кабельные сборки и микроволновые компоненты:

(Применяются в телекоммуникациях гражданского и специального назначения, в средствах связи, РЛС, а так же военной, авиационной и аэрокосмической отраслях промышленности).



Телефон: 8 (812) 309-75-97 (многоканальный)

Факс: 8 (812) 320-03-32

Электронная почта: ocean@oceanchips.ru

Web: <http://oceanchips.ru/>

Адрес: 198099, г. Санкт-Петербург, ул. Калинина, д. 2, корп. 4, лит. А