

### 9 mm Square Rotary Potentiometers with Insulated Shaft

Japan  
Malaysia

Type: **EVUE/EVUF**

#### ■ Features

- Multi-gang block can be provided upon request
- DC voltage available
- Rigid rectangular shape suited for automatic insertion

#### ■ Recommended Applications

- Audio Equipment
- Video Equipment
- Electronic Musical Instruments
- Audio Mixers

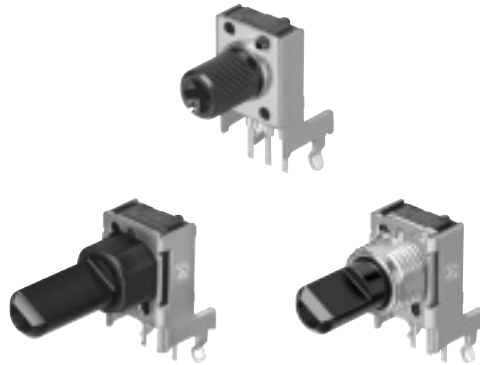

#### ■ Explanation of Part Numbers

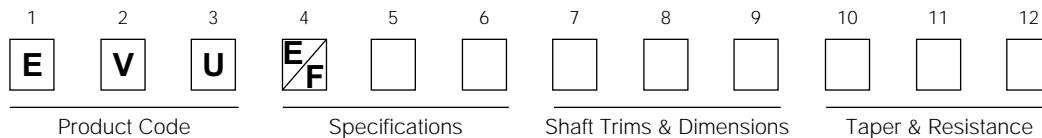

#### ■ Product Chart

Construction	Style	Height (H=mm)	Detent	Type	
Horizontal	Without bushing	6.5	Without detent	EVUE20	
			Midpoint	EVUE30	
		10.0	Without detent	EVUE2A	
			Midpoint	EVUE3A	
		12.5	Without detent	EVUE21	
			Midpoint	EVUE31	
	With bushing	6.5	Without detent	EVUE25	
			Midpoint	EVUE35	
		10.0	Without detent	EVUE2J	
			Midpoint	EVUE3J	
		With sleeve	6.5	Without detent	EVUE27
				Midpoint	EVUE37
10.0	Without detent		EVUE2K		
	Midpoint		EVUE3K		
Vertical	Without bushing	—	Without detent	EVUF2A	
			Midpoint	EVUF3A	
	With bushing	7.5	Without detent	EVUF2J	
			Midpoint	EVUF3J	
		8.5	Without detent	EVUF2M	
			Midpoint	EVUF3M	
	With sleeve	7.5	Without detent	EVUF2K	
			Midpoint	EVUF3K	
		8.5	Without detent	EVUF2L	
			Midpoint	EVUF3L	

Design and specifications are each subject to change without notice. Ask factory for the current technical specifications before purchase and/or use. Should a safety concern arise regarding this product, please be sure to contact us immediately.

### ■ Specifications

Classification	Item	Type without bushing	Type with bushing	Type with sleeve		
Mechanical Specifications	Rotation Angle	300 °				
	Rotation Torque	1 mN·m to 8 mN·m (after rotation started)	1 mN·m to 20 mN·m (after rotation started)	1 mN·m to 20 mN·m (after rotation started)		
	Shaft Stopper Strength	300 mN·m				
	Shaft wobble	<ul style="list-style-type: none"> <li>● Shaft bend and shaft wobble shall be <math>0.8 \times \frac{L}{20}</math> (mm) max. (for one side)</li> <li>( When moment of 25 mN·m is applied. )</li> <li>● L=Distance between mounting surface and measuring point</li> </ul>	<ul style="list-style-type: none"> <li>● Shaft bend and shaft wobble shall be <math>0.5 \times \frac{L}{30}</math> (mm) max. (for one side)</li> <li>( When moment of 50 mN·m is applied. )</li> <li>● L=Distance between mounting surface and measuring point</li> </ul>	<ul style="list-style-type: none"> <li>● Shaft bend and shaft wobble shall be <math>0.7 \times \frac{L}{30}</math> (mm) max. (for one side)</li> <li>( When moment of 50 mN·m is applied. )</li> <li>● L=Distance between mounting surface and measuring point</li> </ul>		
	Shaft Pull/Push Strength	Push strength : 100 N min.   Pull strength : 100 N min.	Push strength : 100 N min.   Pull strength : 100 N min.	Push strength : 100 N min.   Pull strength : 100 N min.		
	Nut Tightening Torque	—	1 N·m max.	—		
Electrical Specifications	Nominal Total Resistance	1 kΩ to 1 MΩ, 300 kΩ to 2 MΩ for taper B (Tolerance ± 20 %)				
	Taper	A, B, C, D, G				
	Power Rating	0.05 W (0 °C to 50 °C) For potentiometers operating in ambient temperatures above 50 °C, Rating should be derated in accordance with the figure on the right.				
	Residual Resistance	Standard	R < 50 kΩ		50 Ω max.	
			50 kΩ < R < 1 MΩ		100 Ω max.	
			1 MΩ < R < 2 MΩ		200 Ω max.	
		Semi-standard	A, B, D, G	B, C, G	A, D	C
			T1 & T2	T2 & T3	T2 & T3	T1 & T2
			R < 2 kΩ		2 Ω max.	20 Ω max.
	2 kΩ < R < 50 kΩ		2 Ω max.	25 Ω max.		
50 kΩ < R < 250 kΩ		25 Ω max.	50 Ω max.			
R > 250 kΩ		100 Ω max.	100 Ω max.			
Insulation Resistance	50 MΩ min. at 250 Vdc					
Dielectric Withstand Voltage	250 Vac for 1 minute					
Noise Level	100 mV max. Apply 20 V (When Voltage Rating < 20 V, use the rated voltage.) Rotate shaft at 30 r/min.					
Endurance	Operating Life	10000 cycles min.				
Minimum Quantity/Packing Unit		EVUE/EVUF : 200 pcs. Polyethylene Bag (Bulk)				
Quantity/Carton		EVUE/EVUF : 2000 pcs.				



■ Dimensions in mm (not to scale)

● Single Type without Bushing

Horizontal, Snap-in

without midpoint detent: EVUE20, EVUE2A, EVUE21

with midpoint detent: EVUE30, EVUE3A, EVUE31

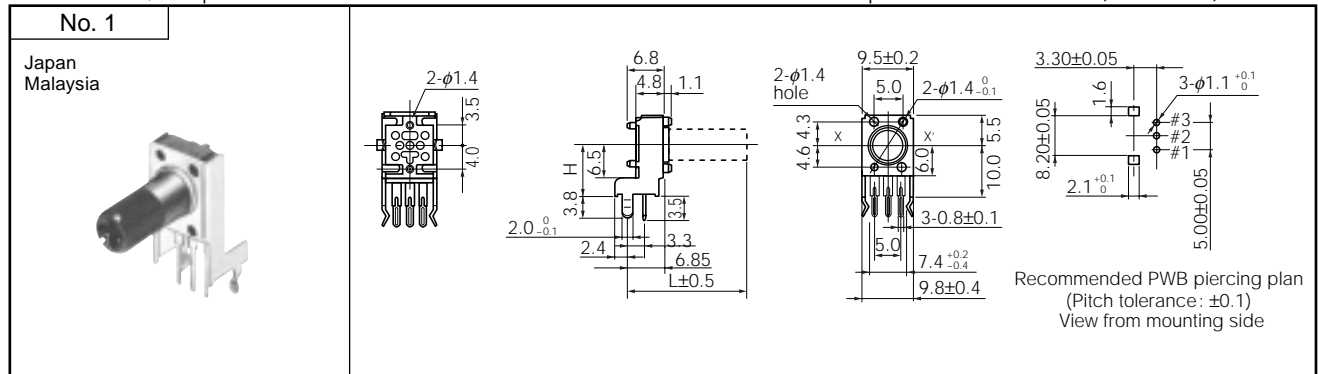

Vertical, Snap-in

without midpoint detent: EVUF2A

with midpoint detent: EVUF3A

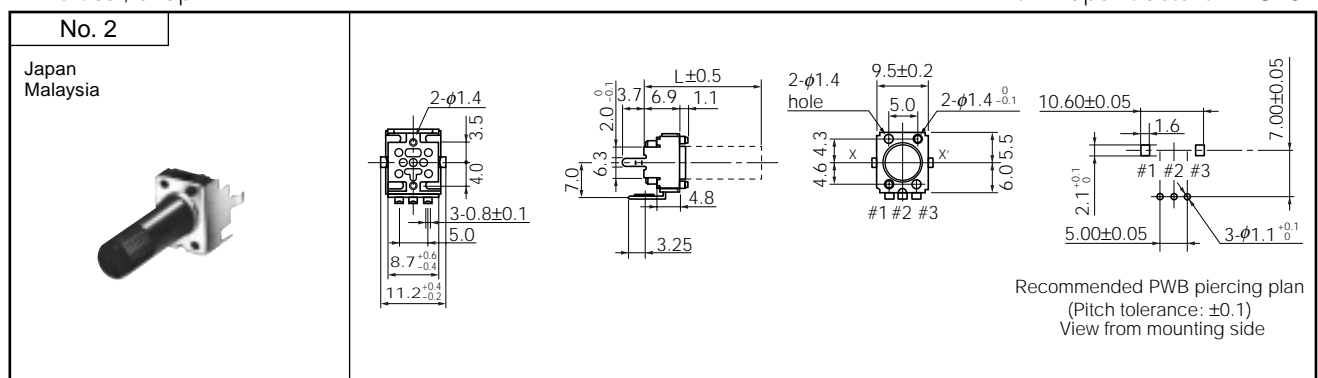

● Single Type with Bushing

Horizontal, Snap-in

without midpoint detent: EVUE25, EVUE2J

with midpoint detent: EVUE35, EVUE3J

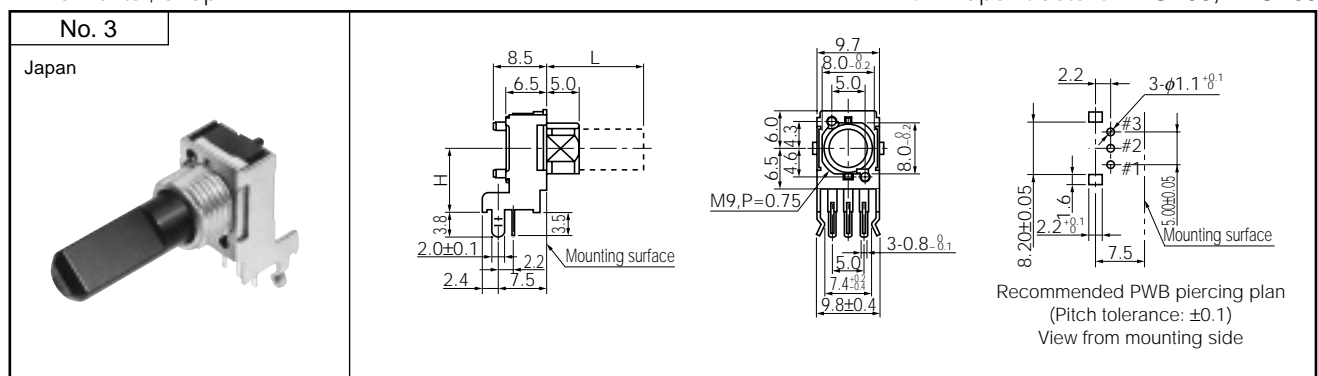

Vertical, Snap-in

without midpoint detent: EVUF2J

with midpoint detent: EVUF3J

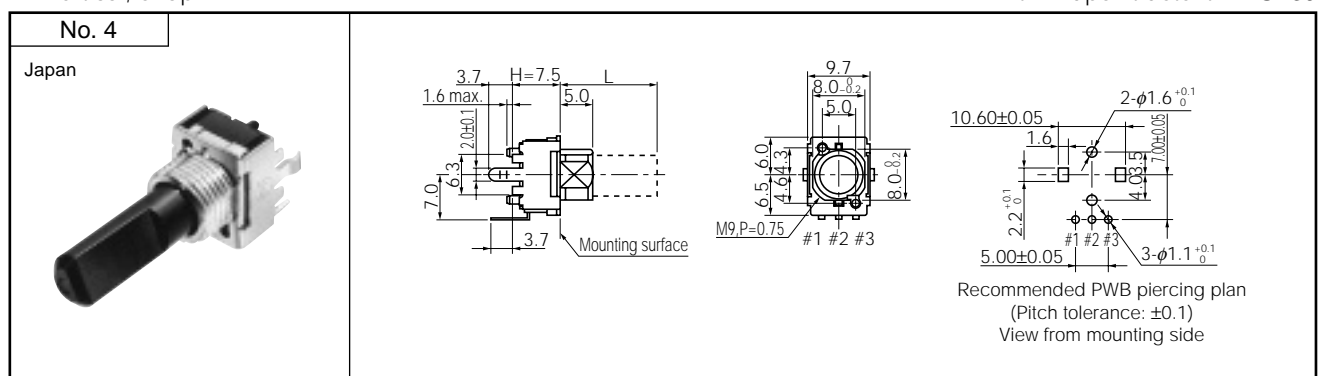

Vertical, Snap-in .....

without midpoint detent: EVUF2M  
with midpoint detent: EVUF3M

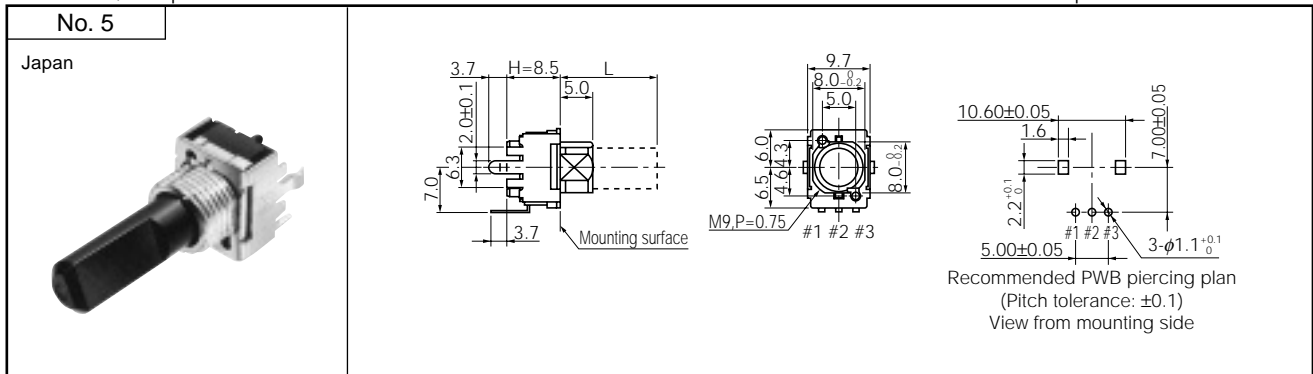

● Single Type with Sleeve

Horizontal, Snap-in, Mounting Height H=10.0 mm .....

without midpoint detent: EVUE27, EVUE2K  
with midpoint detent: EVUE37, EVUE3K

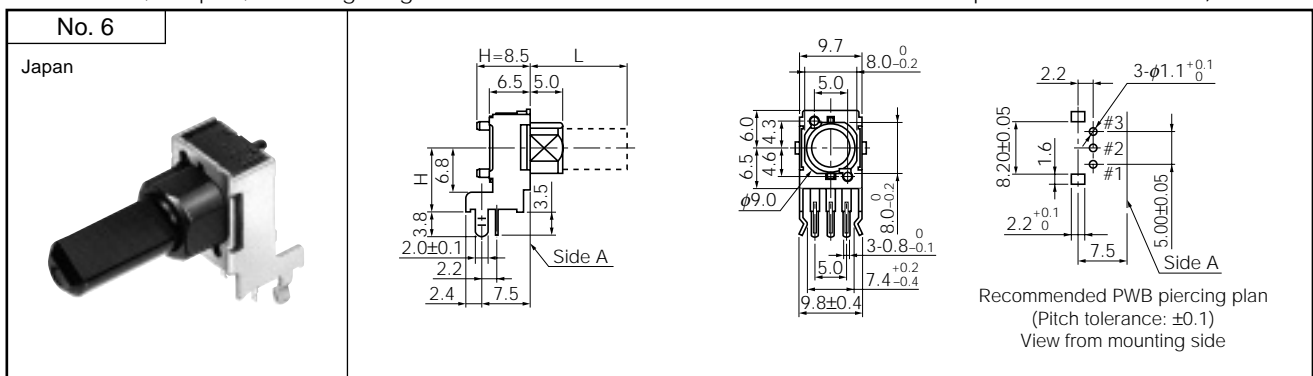

Vertical, Snap-in .....

without midpoint detent: EVUF2K  
with midpoint detent: EVUF3K

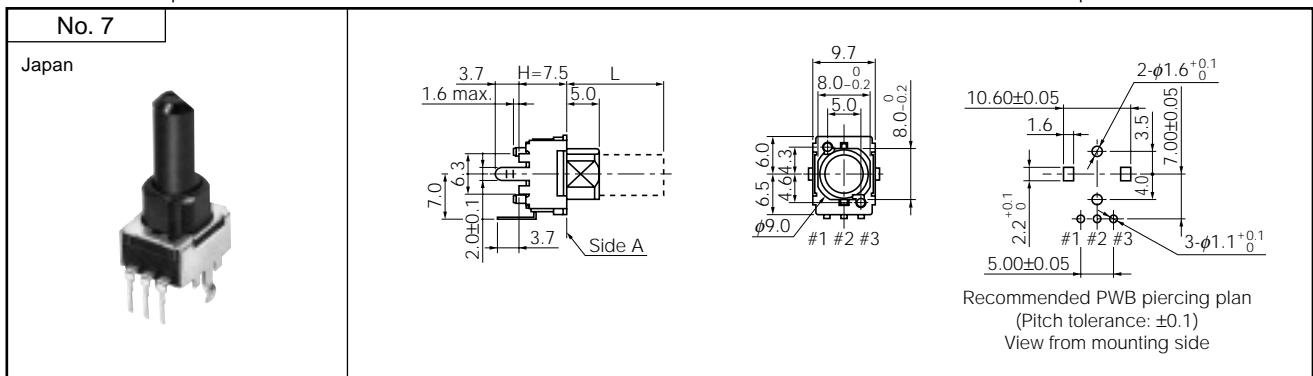

Vertical, Snap-in .....

without midpoint detent: EVUF2L  
with midpoint detent: EVUF3L

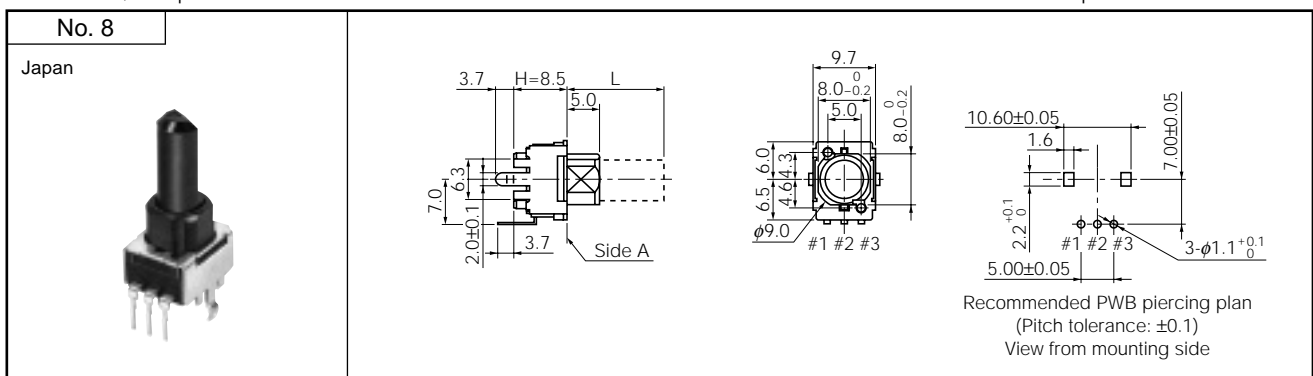

● Shaft Trims and Dimensions in mm for Type without Bushing (Drawings are at full CCW position.)

Type F (Flat)

Product No. 7-8-9 th	F15	F20	F25	F30	
L	15.0	20.0	25.0	30.0	
l	6.0	7.0	12.0	12.0	

Type E (40 teeth serrations)

Product No. 7-8-9 th	E15	E17	E20	E25	E30	E35	
L	15.0	(17.0)	20.0	25.0	30.0	35.0	
l	6.0	7.0	7.0	7.0	7.0	7.0	

Type M (24 teeth serrations)

Product No. 7-8-9 th	M20	M25	M30	M35	
L	20.0	25.0	30.0	35.0	
l	7.0	7.0	7.0	7.0	

Type S (with screw slot)

Product No. 7-8-9 th	S01	
L	9.5	
l	-	

Type H (40 teeth serrations, with screw slot)

Product No. 7-8-9 th	H15	H20	H25	
L	15.0	20.0	25.0	
l	6.0	7.0	7.0	

● Shaft Trims and Dimensions in mm for Types with Bushing or Sleeve (Drawings are at full CCW position.)

Type F (Flat)

Product No. 7-8-9 th	FK1	FK3	FK4	FK5	FL3	FK6	
L	12.5	15.0	17.5	20.0	21.5	22.5	
l	7.0	7.0	12.0	12.0	12.0	12.0	

Note: When you have special requirements other than the above, consult our salesmen.

Design and specifications are each subject to change without notice. Ask factory for the current technical specifications before purchase and/or use. Should a safety concern arise regarding this product, please be sure to contact us immediately.

Компания «Океан Электроники» предлагает заключение долгосрочных отношений при поставках импортных электронных компонентов на взаимовыгодных условиях!

Наши преимущества:

- Поставка оригинальных импортных электронных компонентов напрямую с производств Америки, Европы и Азии, а так же с крупнейших складов мира;
- Широкая линейка поставок активных и пассивных импортных электронных компонентов (более 30 млн. наименований);
- Поставка сложных, дефицитных, либо снятых с производства позиций;
- Оперативные сроки поставки под заказ (от 5 рабочих дней);
- Экспресс доставка в любую точку России;
- Помощь Конструкторского Отдела и консультации квалифицированных инженеров;
- Техническая поддержка проекта, помощь в подборе аналогов, поставка прототипов;
- Поставка электронных компонентов под контролем ВП;
- Система менеджмента качества сертифицирована по Международному стандарту ISO 9001;
- При необходимости вся продукция военного и аэрокосмического назначения проходит испытания и сертификацию в лаборатории (по согласованию с заказчиком);
- Поставка специализированных компонентов военного и аэрокосмического уровня качества (Xilinx, Altera, Analog Devices, Intersil, Interpoint, Microsemi, Actel, Aeroflex, Peregrine, VPT, Syfer, Eurofarad, Texas Instruments, MS Kennedy, Miteq, Cobham, E2V, MA-COM, Hittite, Mini-Circuits, General Dynamics и др.);

Компания «Океан Электроники» является официальным дистрибьютором и эксклюзивным представителем в России одного из крупнейших производителей разъемов военного и аэрокосмического назначения «JONHON», а так же официальным дистрибьютором и эксклюзивным представителем в России производителя высокотехнологичных и надежных решений для передачи СВЧ сигналов «FORSTAR».



## JONHON

«JONHON» (основан в 1970 г.)

Разъемы специального, военного и аэрокосмического назначения:

(Применяются в военной, авиационной, аэрокосмической, морской, железнодорожной, горно- и нефтедобывающей отраслях промышленности)

«FORSTAR» (основан в 1998 г.)

ВЧ соединители, коаксиальные кабели,  
кабельные сборки и микроволновые компоненты:

(Применяются в телекоммуникациях гражданского и специального назначения, в средствах связи, РЛС, а так же военной, авиационной и аэрокосмической отраслях промышленности).



Телефон: 8 (812) 309-75-97 (многоканальный)

Факс: 8 (812) 320-03-32

Электронная почта: [ocean@oceanchips.ru](mailto:ocean@oceanchips.ru)

Web: <http://oceanchips.ru/>

Адрес: 198099, г. Санкт-Петербург, ул. Калинина, д. 2, корп. 4, лит. А