

ISLA214P50

14-Bit, 500MSPS ADC

FN7571
Rev 3.00
Nov 29, 2018

The [ISLA214P50](#) is a 14-bit, 500MSPS analog-to-digital converter designed with the Renesas proprietary FemtoCharge™ technology on a standard CMOS process. The ISLA214P50 is part of a pin-compatible portfolio of 12 to 16-bit A/Ds with maximum sample rates ranging from 130MSPS to 500MSPS.

The device utilizes two time-interleaved 250MSPS unit ADCs to achieve the ultimate sample rate of 500MSPS. A single 500MHz conversion clock is presented to the converter, and all interleave clocking is managed internally. The proprietary Interleave Engine (I2E) performs automatic correction of offset, gain, and sample time mismatches between the unit ADCs to optimize performance.

A Serial Peripheral Interface (SPI) port allows for extensive configurability of the A/D. The SPI also controls the interleave correction circuitry, allowing the system to issue offline and continuous calibration commands as well as configure many dynamic parameters.

Digital output data is presented in selectable LVDS or CMOS formats. The ISLA214P50 is available in a 72 Ld QFN package with an exposed paddle. Operating from a 1.8V supply, performance is specified across the full industrial temperature range (-40 °C to +85 °C).

Key Specifications

- SNR at 500MSPS
 - 72.7dBFS $f_{IN} = 30\text{MHz}$
 - 70.6dBFS $f_{IN} = 363\text{MHz}$
- SFDR at 500MSPS
 - 84dBc $f_{IN} = 30\text{MHz}$
 - 76dBc $f_{IN} = 363\text{MHz}$
- Total power consumption = 835mW at 500MSPS

Features

- Automatic fine interleave correction calibration
- Single supply 1.8V operation
- Clock duty cycle stabilizer
- 75fs clock jitter
- 700MHz bandwidth
- Programmable built-in test patterns
- Multi-ADC support
 - SPI programmable fine gain and offset control
 - Support for multiple ADC synchronization
 - Optimized output timing
- Nap and sleep modes
 - 200µs sleep wake-up time
- Data output clock
- DDR LVDS-compatible or LVCMOS outputs
- Selectable clock divider

Applications

- Radar array processing
- Software defined radios
- Broadband communications
- High-performance data acquisition
- Communications test equipment

Related Literature

For a full list of related documents, visit our website:

- [ISLA214P50](#) device page

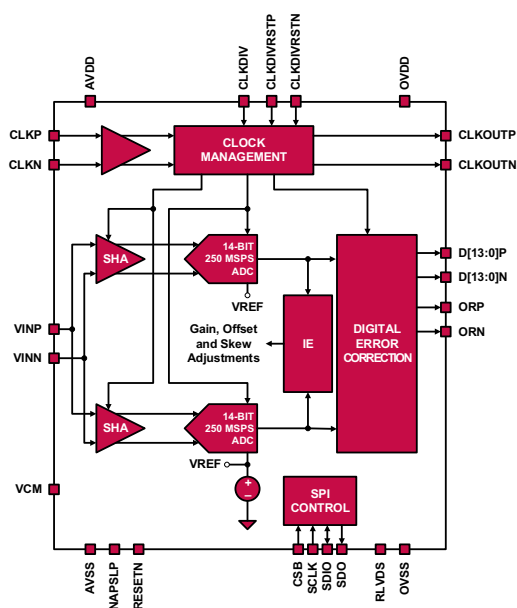

Pin-Compatible Family

MODEL	RESOLUTION	SPEED (MSPS)
ISLA216P25	16	250
ISLA216P20	16	200
ISLA216P13	16	130
ISLA214P50	14	500
ISLA214P25	14	250
ISLA214P20	14	200
ISLA214P13	14	130
ISLA212P50	12	500
ISLA212P25	12	250
ISLA212P20	12	200
ISLA212P13	12	130

Table of Contents

Pin Configuration - LVDS MODE	3
Pin Descriptions - 72 Ld QFN, LVDS Mode	4
Pin Configuration - CMOS MODE	5
Pin Descriptions - 72 Ld QFN, CMOS Mode	5
Absolute Maximum Ratings	7
Thermal Information	7
Electrical Specifications	7
Digital Specifications	9
I2E Specifications	10
Timing Diagrams	11
Switching Specifications	12
Typical Performance Curves	13
Theory of Operation	16
Functional Description	16
Power-On Calibration	16
User Initiated Reset	17
Temperature Calibration	18
Analog Input	18
Clock Input	19
Jitter	19
Voltage Reference	19
Digital Outputs	19
Power Dissipation	20
Nap/Sleep	20
Data Format	20
I2E Requirements and Restrictions	21
Overview	21
Active Run State	21
Power Meter	21
FS/4 Filter	21
Nyquist Zones	21
Configurability and Communication	21
Clock Divider Synchronous Reset	22
Serial Peripheral Interface	24
SPI Physical Interface	24
SPI Configuration	24
Device Information	25
Device Configuration/Control	25
Address 0x60-0x64: I2E Initialization	27
Global Device Configuration/Control	27
SPI Memory Map	31
Equivalent Circuits	34
A/D Evaluation Platform	35
Layout Considerations	35
Split Ground and Power Planes	35
Clock Input Considerations	35
Exposed Paddle	35
Bypass and Filtering	35
LVDS Outputs	35
LVCMOS Outputs	35
Unused Inputs	35
Definitions	35
Revision History	36
Package Outline Drawing	37

Ordering Information

PART NUMBER (Notes 1, 2)	PART MARKING	TEMP. RANGE (°C)	PACKAGE (RoHS Compliant)	PKG. DWG. #
ISLA214P50IRZ	ISLA214P50 IRZ	-40 to +85	72 Ld QFN	L72.10x10E
ISLA214P50IR72EV1Z	Evaluation Board			

NOTES:

- These Pb-free plastic packaged products employ special Pb-free material sets; molding compounds/die attach materials and NiPdAu plate-e4 termination finish, which is RoHS compliant and compatible with both SnPb and Pb-free soldering operations. Pb-free products are MSL classified at Pb-free peak reflow temperatures that meet or exceed the Pb-free requirements of IPC/JEDEC J STD-020.
- For Moisture Sensitivity Level (MSL), see [ISLA214P50](#) device page. For more information about MSL see [TB363](#).

Pin Configuration - LVDS MODE

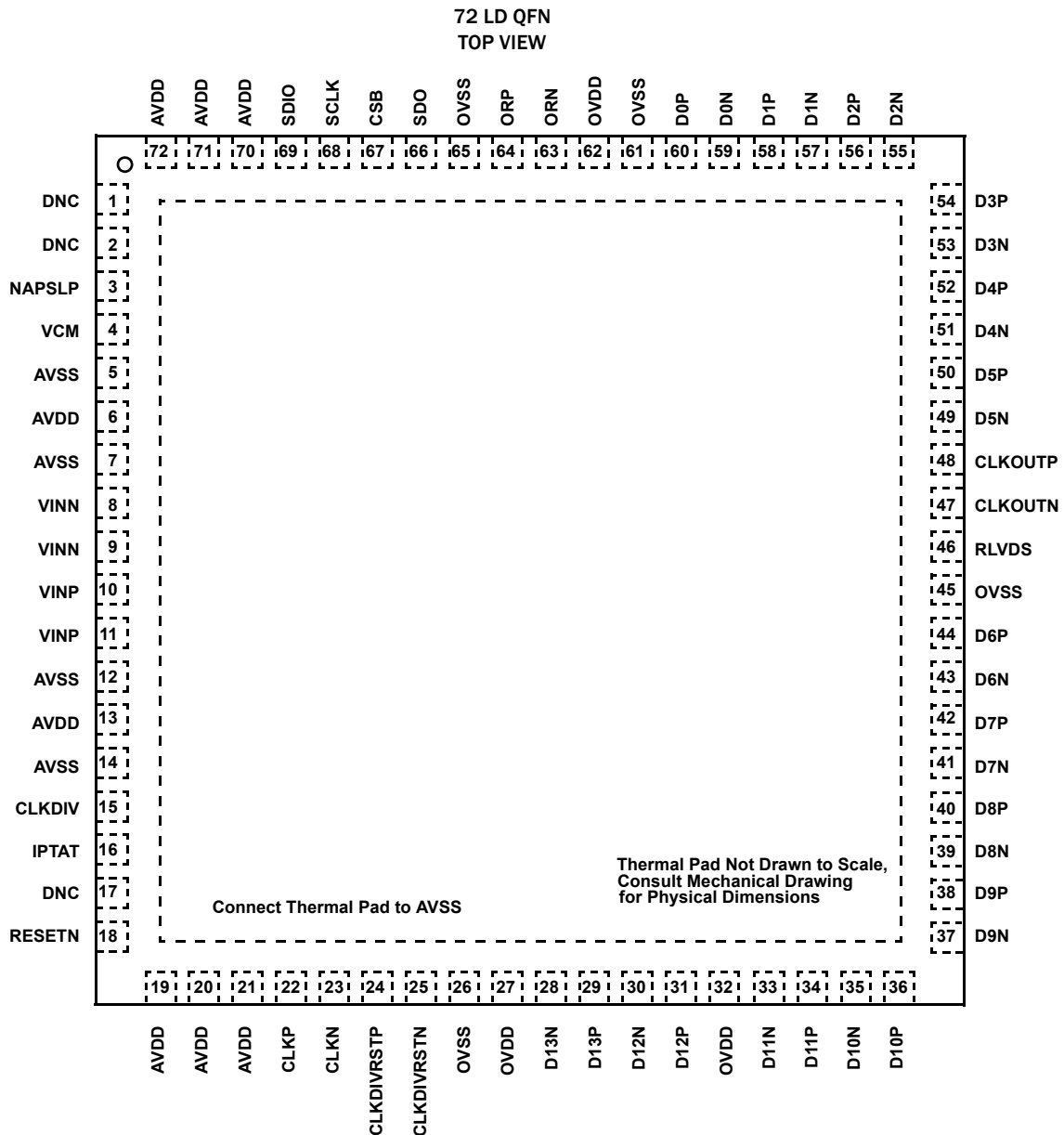

Pin Descriptions - 72 Ld QFN, LVDS Mode

PIN NUMBER	LVDS PIN NAME	LVDS PIN FUNCTION
1, 2, 17	DNC	Do Not Connect
6, 13, 19, 20, 21, 70, 71, 72	AVDD	1.8V Analog Supply
5, 7, 12, 14	AVSS	Analog Ground
27, 32, 62	OVDD	1.8V Output Supply
26, 45, 61, 65	OVSS	Output Ground
3	NAPSLP	Tri-Level Power Control (Nap, Sleep modes)
4	VCM	Common Mode Output
8, 9	VINN	Analog Input Negative
10, 11	VINP	Analog Input Positive
15	CLKDIV	Tri-Level Clock Divider Control
16	IPTAT	Temperature Monitor (Output current proportional to absolute temperature)
18	RESETN	Power On Reset (Active Low)
22, 23	CLKP, CLKN	Clock Input True, Complement
24, 25	CLKDIVRSTP, CLKDIVRSTN	Synchronous Clock Divider Reset True, Complement
28, 29	D13N, D13P	LVDS Bit 13 (MSB) Output Complement, True
30, 31	D12N, D12P	LVDS Bit 12 Output Complement, True
33, 34	D11N, D11P	LVDS Bit 11 Output Complement, True
35, 36	D10N, D10P	LVDS Bit 10 Output Complement, True
37, 38	D9N, D9P	LVDS Bit 9 Output Complement, True
39, 40	D8N, D8P	LVDS Bit 8 Output Complement, True
41, 42	D7N, D7P	LVDS Bit 7 Output Complement, True
43, 44	D6N, D6P	LVDS Bit 6 Output Complement, True
46	RLVDS	LVDS Bias Resistor (connect to OVSS with 1%10k Ω)
47, 48	CLKOUTN, CLKOUTP	LVDS Clock Output Complement, True
49, 50	D5N, D5P	LVDS Bit 5 Output Complement, True
51, 52	D4N, D4P	LVDS Bit 4 Output Complement, True
53, 54	D3N, D3P	LVDS Bit 3 Output Complement, True
55, 56	D2N, D2P	LVDS Bit 2 Output Complement, True
57, 58	D1N, D1P	LVDS Bit 1 Output Complement, True
59, 60	D0N, D0P	LVDS Bit 0 (LSB) Output Complement, True
63, 64	ORN, ORP	LVDS Over Range Complement, True
66	SDO	SPI Serial Data Output
67	CSB	SPI Chip Select (active low)
68	SCLK	SPI Clock
69	SDIO	SPI Serial Data Input/Output
Exposed Paddle	AVSS	Analog Ground

Pin Configuration - CMOS MODE

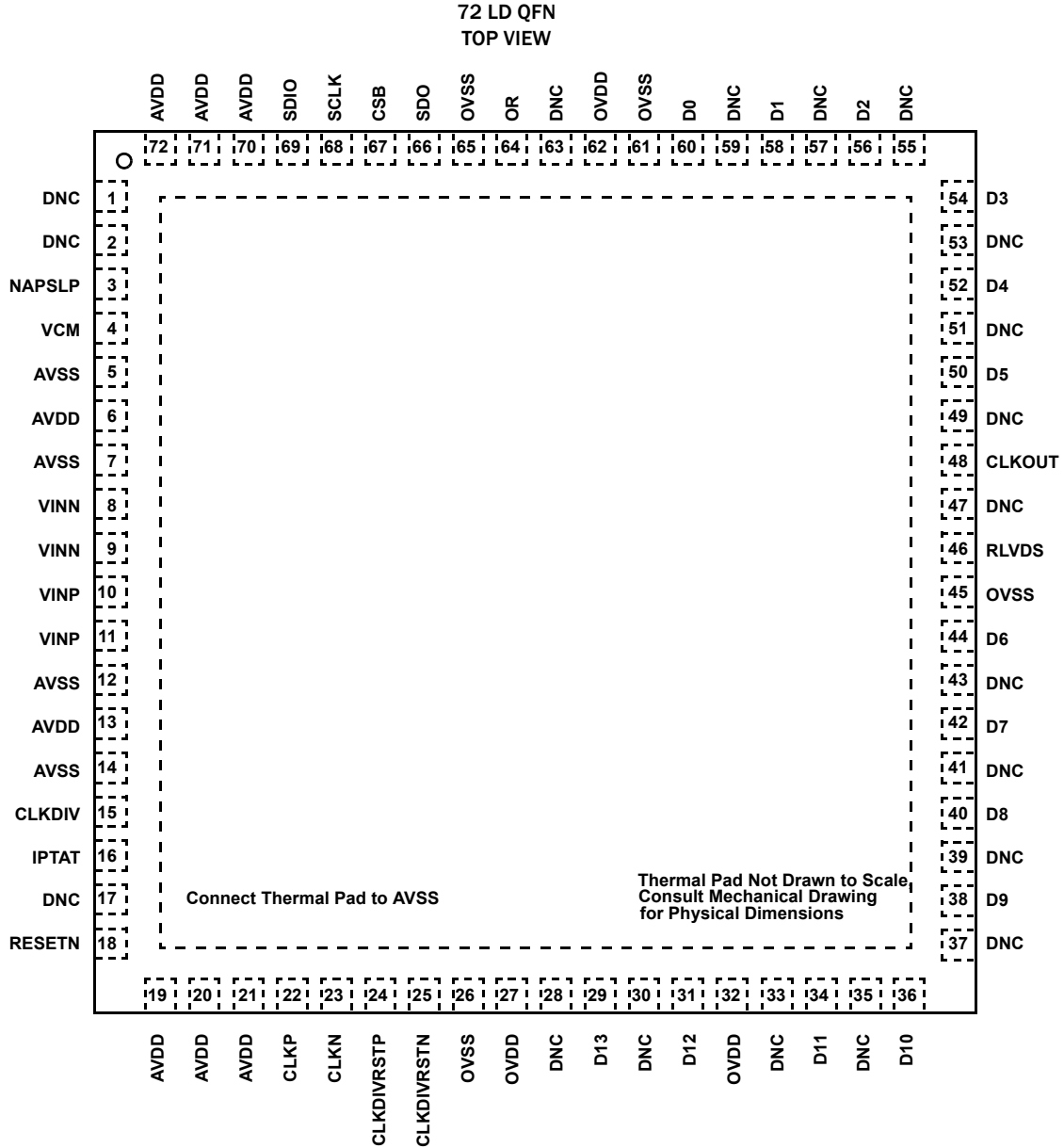

Pin Descriptions - 72 Ld QFN, CMOS Mode

PIN NUMBER	CMOS PIN NAME	CMOS PIN FUNCTION
1, 2, 17, 28, 30, 33, 35, 37, 39, 41, 43, 47, 49, 51, 53, 55, 57, 59, 63	DNC	Do Not Connect
6, 13, 19, 20, 21, 70, 71, 72	AVDD	1.8V Analog Supply
5, 7, 12, 14	AVSS	Analog Ground
27, 32, 62	OVDD	1.8V Output Supply
26, 45, 61, 65	OVSS	Output Ground
3	NAPSLP	Tri-Level Power Control (Nap, Sleep modes)
4	VCM	Common Mode Output
8, 9	VINN	Analog Input Negative

Pin Descriptions - 72 Ld QFN, CMOS Mode (Continued)

PIN NUMBER	CMOS PIN NAME	CMOS PIN FUNCTION
10, 11	VINP	Analog Input Positive
15	CLKDIV	Tri-Level Clock Divider Control
16	IPTAT	Temperature Monitor (Output current proportional to absolute temperature)
18	RESETN	Power On Reset (Active Low)
22, 23	CLKP, CLKN	Clock Input True, Complement
24, 25	CLKDIVRSTP, CLKDIVRSTN	Synchronous Clock Divider Reset True, Complement
29	D13	CMOS Bit 13 (MSB) Output
31	D12	CMOS Bit 12 Output
34	D11	CMOS Bit 11 Output
36	D10	CMOS Bit 10 Output
38	D9	CMOS Bit 9 Output
40	D8	CMOS Bit 8 Output
42	D7	CMOS Bit 7 Output
44	D6	CMOS Bit 6 Output
46	RLVDS	LVDS Bias Resistor (connect to OVSS with 1%10k Ω)
48	CLKOUT	CMOS Clock Output
50	D5	CMOS Bit 5 Output
52	D4	CMOS Bit 4 Output
54	D3	CMOS Bit 3 Output
56	D2	CMOS Bit 2 Output
58	D1	CMOS Bit 1 Output
60	D0	CMOS Bit 0 (LSB) Output
64	OR	CMOS Over Range
66	SDO	SPI Serial Data Output
67	CSB	SPI Chip Select (active low)
68	SCLK	SPI Clock
69	SDIO	SPI Serial Data Input/Output
Exposed Paddle	AVSS	Analog Ground

Absolute Maximum Ratings

AVDD to AVSS	-0.4V to 2.1V
OVDD to OVSS	-0.4V to 2.1V
AVSS to OVSS	-0.3V to 0.3V
Analog Inputs to AVSS	-0.4V to AVDD + 0.3V
Clock Inputs to AVSS	-0.4V to AVDD + 0.3V
Logic Input to AVSS	-0.4V to OVDD + 0.3V
Logic Inputs to OVSS	-0.4V to OVDD + 0.3V
ESD Rating	
Human Body Model (Tested per JESD22-A114F)	2kV
Charged Device Model (Tested per JESD22-C101E)	1kV
Latch-Up (Tested per JESD-78C; Class 2, Level A)	100mA

Thermal Information

Thermal Resistance (Typical)	θ_{JA} (°C/W)	θ_{JC} (°C/W)
72 Ld QFN (Notes 3, 4)	23	0.9
Operating Temperature	-40°C to +85°C	
Storage Temperature	-65°C to +150°C	
Junction Temperature	+150°C	
Pb-Free Reflow Profile	see TB493	

CAUTION: Do not operate at or near the maximum ratings listed for extended periods of time. Exposure to such conditions can adversely impact product reliability and result in failures not covered by warranty.

NOTES:

- θ_{JA} is measured in free air with the component mounted on a high-effective thermal conductivity test board with "direct attach" features. See [TB379](#).
- For θ_{JC} , the "case temp" location is the center of the exposed metal pad on the package underside.

Electrical Specifications All specifications apply under the following conditions unless otherwise noted: AVDD = 1.8V, OVDD = 1.8V, T_A = -40°C to +85°C (typical specifications at +25°C), A_{IN} = -1dBFS, f_{SAMPLE} = 500MSPS. **Boldface limits apply across the operating temperature range, -40°C to +85°C.**

PARAMETER	SYMBOL	CONDITIONS	MIN (Note 5)	TYP	MAX (Note 5)	UNIT
DC SPECIFICATIONS (Note 6)						
Analog Input						
Full-Scale Analog Input Range	V_{FS}	Differential	1.95	2.0	2.15	V_{P-P}
Input Resistance	R_{IN}	Differential		300		Ω
Input Capacitance	C_{IN}	Differential		9		pF
Full Scale Range Temperature Drift	A_{VTC}	Full Temperature		160		ppm/°C
Input Offset Voltage	V_{OS}		-5.0	-1.3	5.0	mV
Common-Mode Output Voltage	V_{CM}			0.94		V
Common-Mode Input Current (per pin)	I_{CM}			2.6		$\mu A/MSPS$
Clock Inputs						
Inputs Common Mode Voltage				0.9		V
CLKP, CLKN Input Swing				1.8		V
Power Requirements						
1.8V Analog Supply Voltage	AVDD		1.7	1.8	1.9	V
1.8V Digital Supply Voltage	OVDD		1.7	1.8	1.9	V
1.8V Analog Supply Current	I_{AVDD}			374	391	mA
1.8V Digital Supply Current (Note 6)	I_{OVDD}	3mA LVDS, (I2E powered down, Fs/4 filter powered down)		90	104	mA
Power Supply Rejection Ratio	PSRR	30MHz, 45mV _{P-P} signal on AVDD		60		dB

Electrical Specifications All specifications apply under the following conditions unless otherwise noted: AVDD = 1.8V, OVDD = 1.8V, T_A = -40 °C to +85 °C (typical specifications at +25 °C), A_{IN} = -1dBFS, f_{SAMPLE} = 500MSPS. **Boldface limits apply across the operating temperature range, -40 °C to +85 °C. (Continued)**

PARAMETER	SYMBOL	CONDITIONS	MIN (Note 5)	TYP	MAX (Note 5)	UNIT
Total Power Dissipation						
Normal Mode	P _D	2mA LVDS, (I2E powered down, Fs/4 filter powered down)		809		mW
		3mA LVDS, (I2E powered down, Fs/4 filter powered down)		835	891	mW
		3mA LVDS, (I2E on, Fs/4 filter off)		867		mW
		3mA LVDS, (I2E on, Fs/4 filter on)		900	958	mW
Nap Mode	P _D		89	104	mW	
Sleep Mode	P _D	CSB at logic high		7	19	mW
Nap/Sleep Mode Wakeup Time		Sample clock running		200		μs
AC SPECIFICATIONS						
Differential Nonlinearity	DNL	f _{IN} = 105MHz No missing codes	-0.99	±0.5	1.4	LSB
Integral Nonlinearity	INL	f _{IN} = 105MHz		±2.5		LSB
Minimum Conversion Rate (Note 7)	f _S MIN				80	MSPS
Maximum Conversion Rate	f _S MAX		500			MSPS
Signal-to-Noise Ratio (Note 8)	SNR	f _{IN} = 30MHz		72.7		dBFS
		f _{IN} = 105MHz	69.0	72.6		dBFS
		f _{IN} = 190MHz		71.9		dBFS
		f _{IN} = 363MHz		70.6		dBFS
		f _{IN} = 461MHz		70.0		dBFS
		f _{IN} = 605MHz		68.3		dBFS
Signal-to-Noise and Distortion (Note 8)	SINAD	f _{IN} = 30MHz		72.2		dBFS
		f _{IN} = 105MHz	68.5	71.7		dBFS
		f _{IN} = 190MHz		70.7		dBFS
		f _{IN} = 363MHz		69.3		dBFS
		f _{IN} = 461MHz		64.7		dBFS
		f _{IN} = 605MHz		60.7		dBFS
Effective Number of Bits (Note 8)	ENOB	f _{IN} = 30MHz		11.70		Bits
		f _{IN} = 105MHz	11.09	11.62		Bits
		f _{IN} = 190MHz		11.44		Bits
		f _{IN} = 363MHz		11.22		Bits
		f _{IN} = 461MHz		10.45		Bits
		f _{IN} = 605MHz		9.79		Bits

Electrical Specifications All specifications apply under the following conditions unless otherwise noted: AVDD = 1.8V, OVDD = 1.8V, T_A = -40 °C to +85 °C (typical specifications at +25 °C), A_{IN} = -1dBFS, f_{SAMPLE} = 500MSPS. **Boldface limits apply across the operating temperature range, -40 °C to +85 °C. (Continued)**

PARAMETER	SYMBOL	CONDITIONS	MIN (Note 5)	TYP	MAX (Note 5)	UNIT
Spurious-Free Dynamic Range (Note 8)	SFDR	f _{IN} = 30MHz		84		dBc
		f _{IN} = 105MHz	72	82		dBc
		f _{IN} = 190MHz		78		dBc
		f _{IN} = 363MHz		76		dBc
		f _{IN} = 461MHz		66		dBc
		f _{IN} = 605MHz		61		dBc
Spurious-Free Dynamic Range Excluding H2, H3 (Note 8)	SFDRX23	f _{IN} = 30MHz		88		dBc
		f _{IN} = 105MHz		89		dBc
		f _{IN} = 190MHz		88		dBc
		f _{IN} = 363MHz		83		dBc
		f _{IN} = 461MHz		84		dBc
		f _{IN} = 605MHz		77		dBc
Intermodulation Distortion	IMD	f _{IN} = 70MHz		88		dBFS
		f _{IN} = 170MHz		96		dBFS
Word Error Rate	WER			10 ⁻¹²		
Full Power Bandwidth	FPBW			700		MHz

NOTES:

- Compliance to datasheet limits is assured by one of the following methods: production test, characterization, and/or design.
- Digital Supply Current is dependent upon the capacitive loading of the digital outputs. I_{OVDD} specifications apply for 10pF load on each digital output.
- The DLL Range setting must be changed for low speed operation.
- Minimum specification ensured when calibrated at +85 °C.

Digital Specifications Boldface limits apply across the operating temperature range, -40 °C to +85 °C.

PARAMETER	SYMBOL	CONDITIONS	MIN (Note 5)	TYP	MAX (Note 5)	UNIT
INPUTS (Note 9)						
Input Current High (RESETN)	I _{IH}	V _{IN} = 1.8V	0	1	10	μA
Input Current Low (RESETN)	I _{IL}	V _{IN} = 0V	-25	-12	-8	μA
Input Current High (SDIO)	I _{IH}	V _{IN} = 1.8V		4	12	μA
Input Current Low (SDIO)	I _{IL}	V _{IN} = 0V	-600	-415	-300	μA
Input Current High (CSB)	I _{IH}	V _{IN} = 1.8V	40	58	75	μA
Input Current Low (CSB)	I _{IL}	V _{IN} = 0V		5	10	μA
Input Current High (CLKDIV)	I _{IH}		16	25	34	μA
Input Current Low (CLKDIV)	I _{IL}		-34	-25	-16	μA
Input Voltage High (SDIO, RESETN)	V _{IH}		1.17			V
Input Voltage Low (SDIO, RESETN)	V _{IL}				.63	V
Input Capacitance	C _{DI}			4		pF
LVDS INPUTS (CLKRSTP, CLKRSTN)						
Input Common-Mode Range	V _{ICM}		825		1575	mV
Input Differential Swing (peak-to-peak, single-ended)	V _{ID}		250		450	mV

Digital Specifications Boldface limits apply across the operating temperature range, -40°C to +85°C. (Continued)

PARAMETER	SYMBOL	CONDITIONS	MIN (Note 5)	TYP	MAX (Note 5)	UNIT
CLKDIVRSTP Input Pull-Down Resistance	R _{lpd}			100		kΩ
CLKDIVRSTN Input Pull-Up Resistance	R _{lpu}			100		kΩ
LVDS OUTPUTS						
Differential Output Voltage (Note 10)	V _T	3mA mode		612		mV _{p,p}
Output Offset Voltage	V _{OS}	3mA mode	1120	1150	1200	mV
Output Rise Time	t _R			240		ps
Output Fall Time	t _F			240		ps
CMOS OUTPUTS						
Voltage Output High	V _{OH}	I _{OH} = -500μA	OVDD - 0.3	OVDD - 0.1		V
Voltage Output Low	V _{OL}	I _{OL} = 1mA		0.1	0.3	V
Output Rise Time	t _R			1.8		ns
Output Fall Time	t _F			1.4		ns

NOTES:

9. The tri-level inputs internal switching thresholds are approximately 0.43V and 1.34V. It is advised to float the inputs, tie to ground or AVDD depending on desired function.
10. The voltage is expressed in peak-to-peak differential swing. The peak-to-peak singled-ended swing is 1/2 of the differential swing.

I2E Specifications Boldface limits apply across the operating temperature range, -40°C to +85°C.

PARAMETER	SYMBOL	CONDITIONS	MIN (Note 5)	TYP	MAX (Note 5)	UNIT
Offset Mismatch-induced Spurious Power		No I2E calibration performed		-65		dBFS
		Active Run state enabled		-70		dBFS
I2E Settling Times	I2Epost_t	Calibration settling time for Active Run state			1000	ms
Minimum Duration of Valid Analog Input	t _{TE}	Allow one I2E iteration of Offset, Gain and Phase correction			100	μs
Largest Interleave Spur		f _{IN} = 10MHz to 240MHz, Active Run State enabled, in Track mode		-99		dBc
		f _{IN} = 10MHz to 240MHz, Active Run State enabled and previously settled, in Hold mode	-75	-80		dBc
		f _{IN} = 260MHz to 490MHz, Active Run State enabled, in Track mode		-99		dBc
		f _{IN} = 260MHz to 490MHz, Active Run State enabled and previously settled, in Hold mode		-75		dBc
Total Interleave Spurious Power		Active Run State enabled, in Track mode, f _{IN} is a broadband signal in the 1 st Nyquist zone		-85		dBc
		Active Run State enabled, in Track mode, f _{IN} is a broadband signal in the 2 nd Nyquist zone		-75		dBc
Sample Time Mismatch Between Unit ADCs		Active Run State enabled, in Track mode		25		fs
Gain Mismatch Between Unit ADCs				0.01		%FS
Offset Mismatch Between Unit ADCs				1		mV

Timing Diagrams

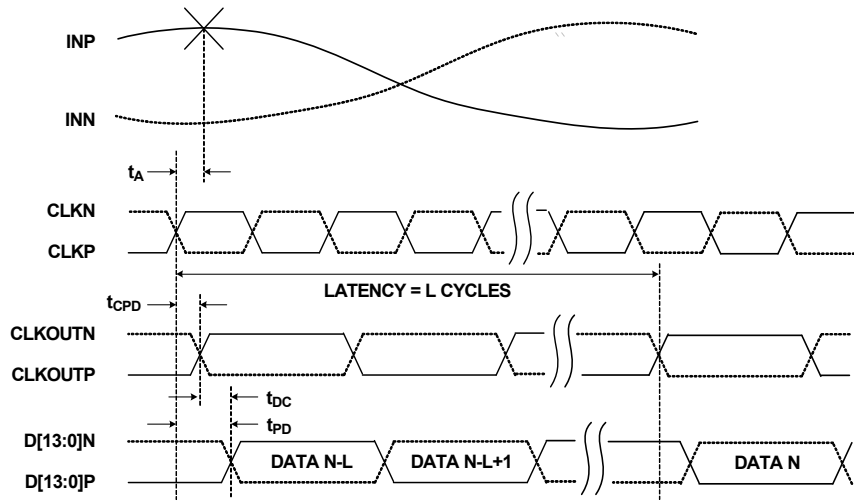

FIGURE 1A. LVDS

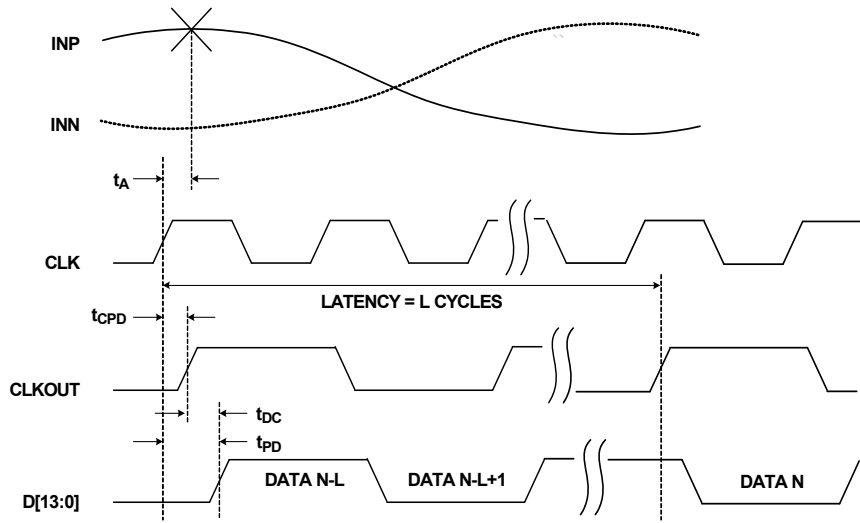

FIGURE 1B. CMOS

FIGURE 1. TIMING DIAGRAMS

Switching Specifications Boldface limits apply across the operating temperature range, -40°C to +85°C.

PARAMETER	CONDITION	SYMBOL	MIN (Note 5)	TYP	MAX (Note 5)	UNIT
ADC OUTPUT						
Aperture Delay		t_A		114		ps
RMS Aperture Jitter		j_A		75		fs
Input Clock to Output Clock Propagation Delay	AVDD, OVDD = 1.7V to 1.9V, $T_A = -40^\circ\text{C}$ to $+85^\circ\text{C}$	t_{CPD}	1.65	2.4	3	ns
	AVDD, OVDD = 1.8V, $T_A = +25^\circ\text{C}$	t_{CPD}	1.9	2.3	2.75	ns
Relative Input Clock to Output Clock Propagation Delay (Note 13)	AVDD, OVDD = 1.7V to 1.9V, $T_A = -40^\circ\text{C}$ to $+85^\circ\text{C}$	dt_{CPD}	-450		450	ps
Input Clock to Data Propagation Delay		t_{PD}	1.65	2.4	3.5	ns
Output Clock to Data Propagation Delay, LVDS Mode	Rising/falling edge	t_{DC}	-0.1	0.16	0.5	ns
Output Clock to Data Propagation Delay, CMOS Mode	Rising/falling edge	t_{DC}	-0.1	0.2	0.65	ns
Synchronous Clock Divider Reset Setup Time (with respect to the positive edge of CLKP)		t_{RSTS}	0.4	0.06		ns
Synchronous Clock Divider Reset Hold Time (with respect to the positive edge of CLKP)		t_{RSTH}		0.02	0.35	ns
Synchronous Clock Divider Reset Recovery Time	DLL recovery time after synchronous reset	t_{RSTRT}		52		μs
Latency (Pipeline Delay)		L		20		cycles
Overvoltage Recovery		t_{OVR}		2		cycles
SPI INTERFACE (Notes 11, 12)						
SCLK Period	Write operation	t_{CLK}	32			cycles
	Read operation	t_{CLK}	32			cycles
CSB \downarrow to SCLK \uparrow Setup Time	Read or Write	t_S	56			cycles
CSB \uparrow after SCLK \uparrow Hold Time	Write	t_H	10			cycles
Data Valid to SCLK \uparrow Setup Time	Write	t_{DS}	12			cycles
Data Valid after SCLK \uparrow Hold Time	Read or Write	t_{DH}			8	cycles
Data Valid after SCLK \downarrow Time	Read	t_{DVR}			10	cycles

NOTES:

- SPI interface timing is directly proportional to the ADC sample period (t_S). Values above reflect multiples of a 4ns sample period, and must be scaled proportionally for lower sample rates. ADC sample clock must be running for SPI communication.
- The SPI may operate asynchronously with respect to the ADC sample clock.
- The relative propagation delay is the difference in propagation time between any two devices that are matched in temperature and voltage, and is specified across the full operating temperature and voltage range.

Typical Performance Curves

All typical performance characteristics apply under the following conditions unless otherwise noted: AVDD = OVDD = 1.8V, T_A = +25 °C, A_{IN} = -1dBFS, f_{IN} = 105MHz, f_{SAMPLE} = 500MSPS.

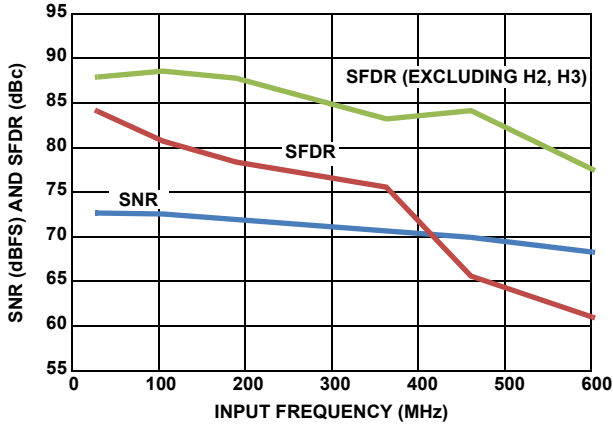

FIGURE 2. SNR AND SFDR vs f_{IN}

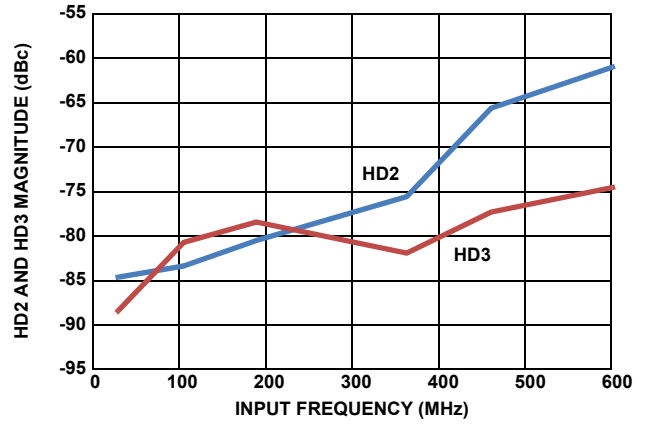

FIGURE 3. HD2 AND HD3 vs f_{IN}

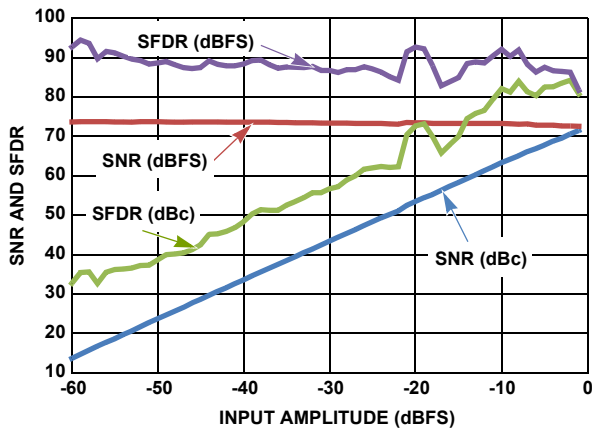

FIGURE 4. SNR AND SFDR vs A_{IN}

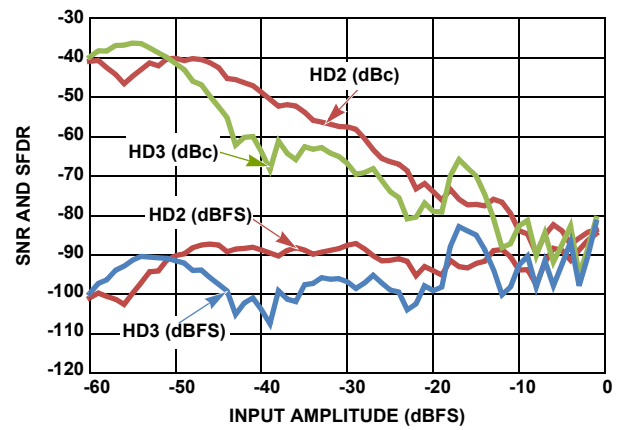

FIGURE 5. HD2 AND HD3 vs A_{IN}

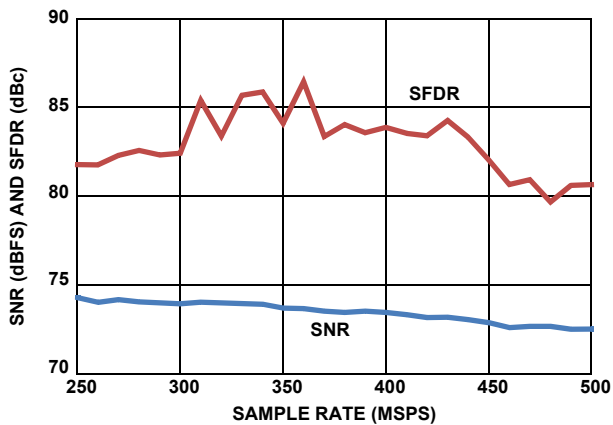

FIGURE 6. SNR AND SFDR vs f_{SAMPLE}

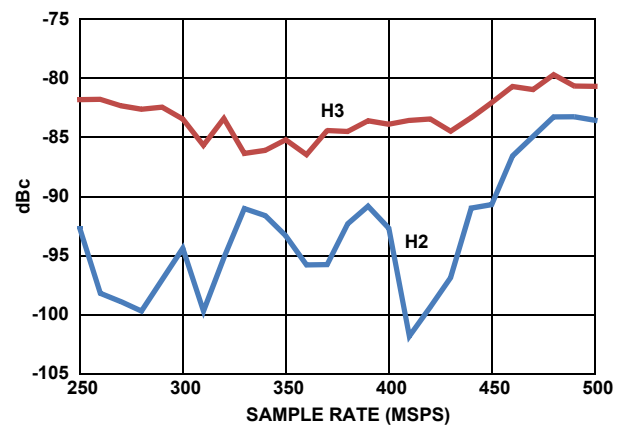

FIGURE 7. HD2 AND HD3 vs f_{SAMPLE}

Typical Performance Curves

All typical performance characteristics apply under the following conditions unless otherwise noted: AVDD = OVDD = 1.8V, TA = +25°C, AIN = -1dBFS, fIN = 105MHz, fSAMPLE = 500MSPS. (Continued)

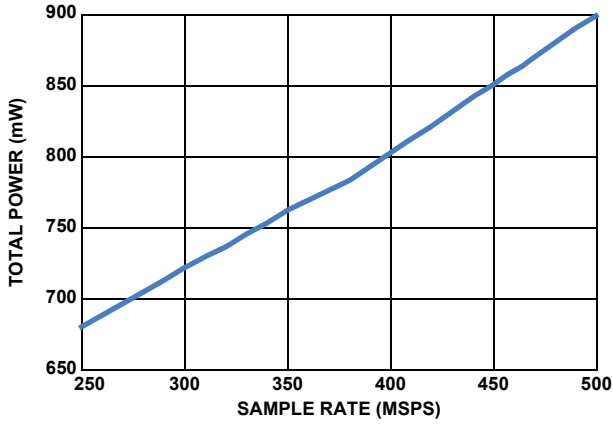

FIGURE 8. POWER vs f_{SAMPLE} IN 3mA LVDS MODE

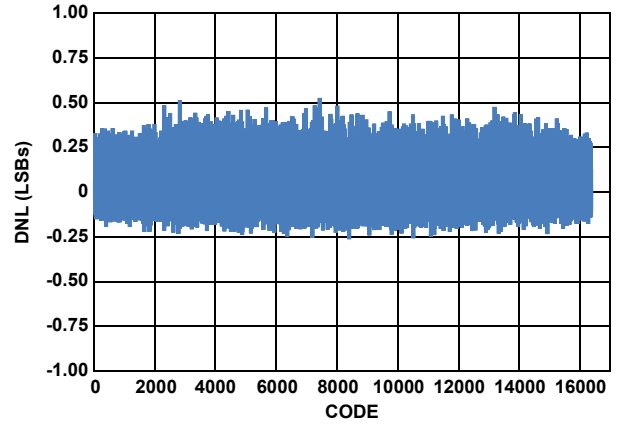

FIGURE 9. DIFFERENTIAL NONLINEARITY

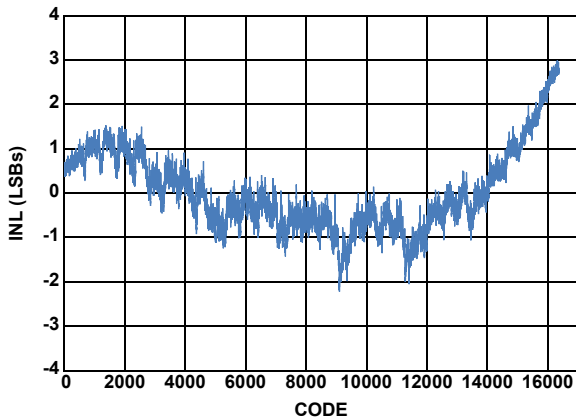

FIGURE 10. INTEGRAL NONLINEARITY

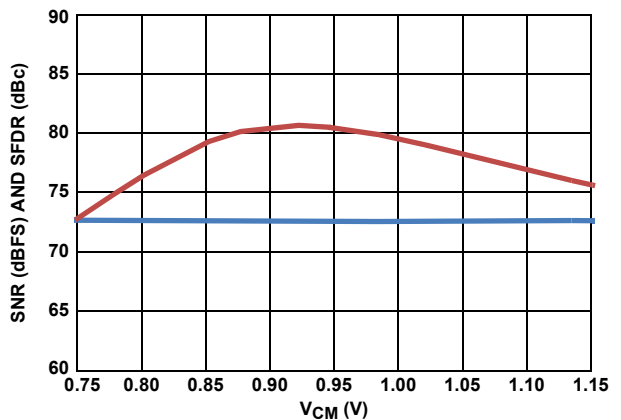

FIGURE 11. SNR AND SFDR vs V_{CM}

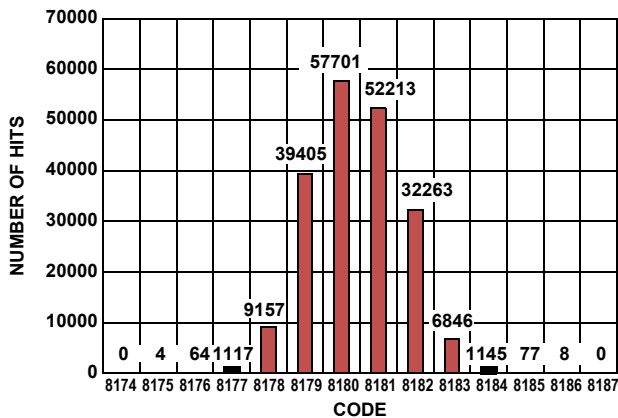

FIGURE 12. NOISE HISTOGRAM

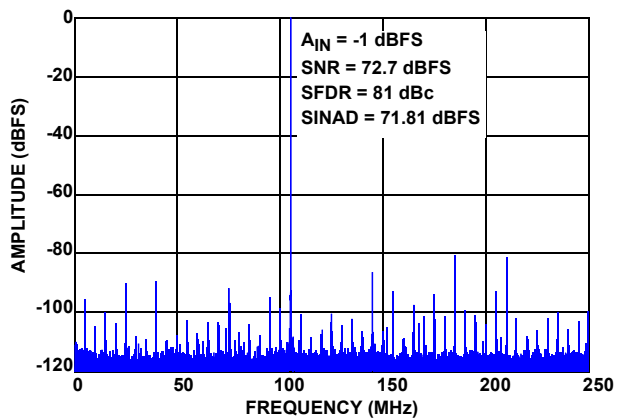

FIGURE 13. SINGLE-TONE SPECTRUM AT 105MHz

Typical Performance Curves

All typical performance characteristics apply under the following conditions unless otherwise noted: AVDD = OVDD = 1.8V, T_A = +25 °C, A_{IN} = -1dBFS, f_{IN} = 105MHz, f_{SAMPLE} = 500MSPS. (Continued)

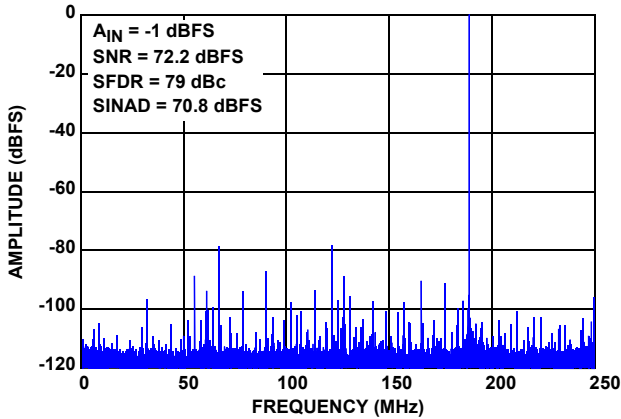

FIGURE 14. SINGLE-TONE SPECTRUM AT 190MHz

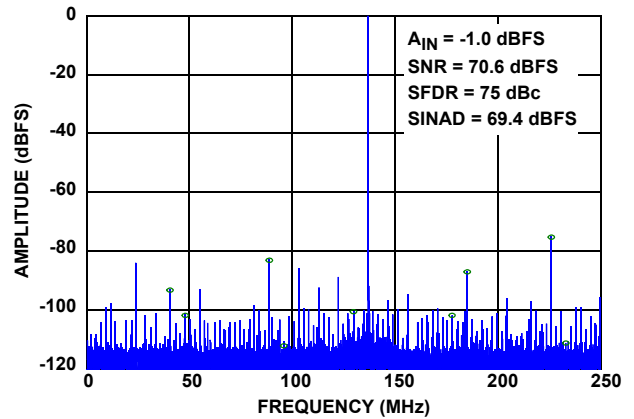

FIGURE 15. SINGLE-TONE SPECTRUM AT 363MHz

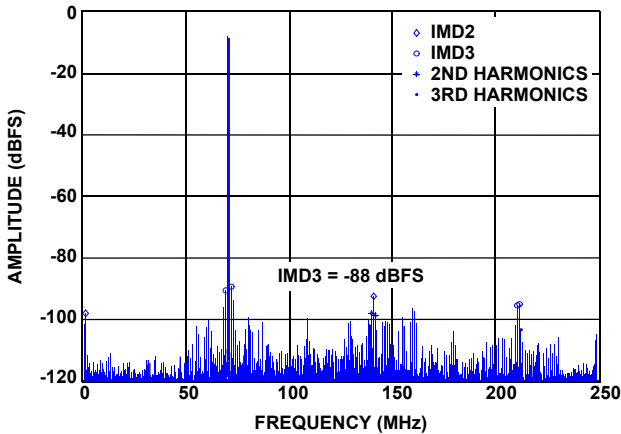

FIGURE 16. TWO-TONE SPECTRUM (F1 = 70MHz, F2 = 71MHz -7dBFS)

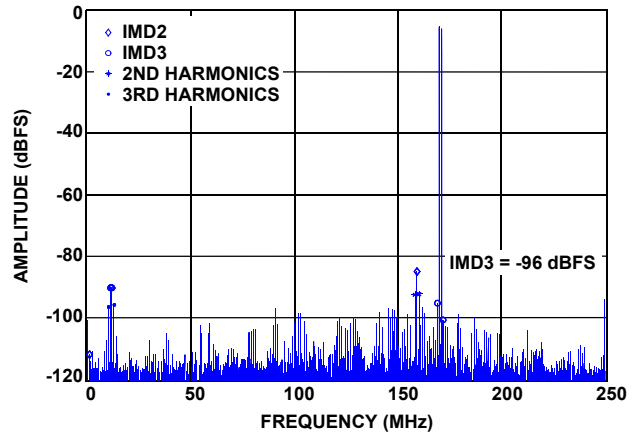

FIGURE 17. TWO-TONE SPECTRUM (F1 = 170MHz, F2 = 171MHz -7dBFS)

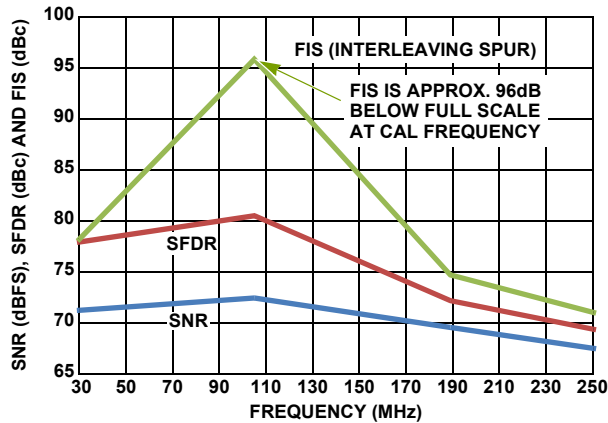

FIGURE 18. INPUT FREQUENCY SWEEP WITH I2E FROZEN, I2E PREVIOUSLY CALIBRATED AT 105MHz

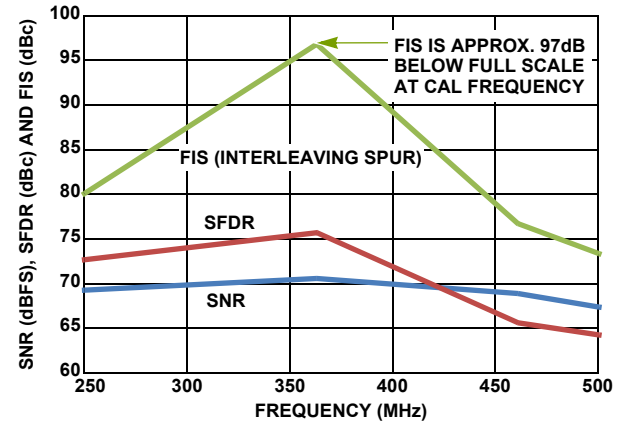

FIGURE 19. INPUT FREQUENCY SWEEP WITH I2E FROZEN, I2E PREVIOUSLY CALIBRATED AT 363MHz

Typical Performance Curves

All typical performance characteristics apply under the following conditions unless otherwise noted: AVDD = OVDD = 1.8V, T_A = +25°C, A_{IN} = -1dBFS, f_{IN} = 105MHz, f_{SAMPLE} = 500MSPS. (Continued)

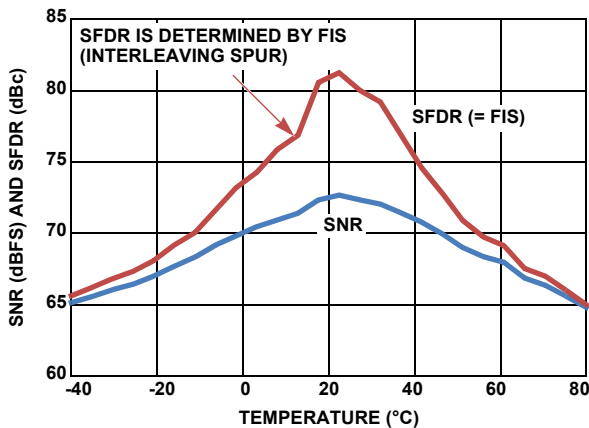

FIGURE 20. TEMPERATURE SWEEP WITH I2E FROZEN, I2E PREVIOUSLY CALIBRATED AT +25°C, F_{IN} = 105MHz

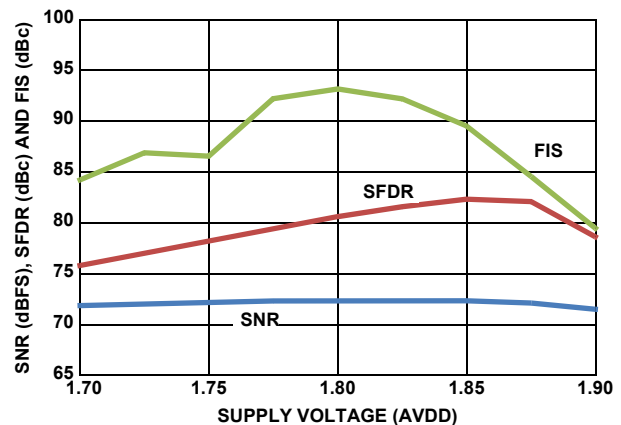

FIGURE 21. ANALOG SUPPLY VOLTAGE SWEEP WITH I2E FROZEN, I2E PREVIOUSLY CALIBRATED AT 1.8V, F_{IN} = 105MHz

Theory of Operation

Functional Description

The ISLA214P50 is based upon a 14-bit, 250MSPS A/D converter core that uses a pipelined successive approximation architecture (Figure 22 on page 17). The input voltage is captured by a Sample-Hold Amplifier (SHA) and converted to a unit of charge. Proprietary charge-domain techniques are used to successively compare the input to a series of reference charges. Decisions made during the successive approximation operations determine the digital code for each input value. Digital error correction is also applied, resulting in a total latency of 20 clock cycles. This is evident to the user as a latency between the start of a conversion and the data being available on the digital outputs.

The device contains two core A/D converters with carefully matched transfer characteristics. The cores are clocked on alternate clock edges, resulting in a doubling of the sample rate.

Time-interleaved A/D systems can exhibit non-ideal artifacts in the frequency domain if the individual core A/D characteristics are not well matched. Gain, offset, and timing skew mismatches are of primary concern.

The Interleave Engine (I2E) performs automatic interleave calibration for the offset, gain, and sample time skew mismatch between the core A/Ds. The I2E circuitry also adjusts in real-time for temperature and voltage variations.

Residual gain and sample time skew mismatch result in fundamental image spurs at $f_{\text{NYQUIST}} \pm f_{\text{IN}}$. Offset mismatches create spurs at DC and multiples of f_{NYQUIST} .

Power-On Calibration

As mentioned previously, the cores perform a self-calibration at start-up. An internal Power-On Reset (POR) circuit detects the supply voltage ramps and initiates the calibration when the analog and digital supply voltages are above a threshold. The

following conditions must be followed for the power-on calibration to execute successfully:

- A frequency-stable conversion clock must be applied to the CLKP/CLKN pins
- DNC pins must not be connected
- SDO has an internal pull-up and should not be driven externally
- RESETN is pulled low by the ADC internally during POR. External driving of RESETN is optional
- SPI communications must not be attempted

A user-initiated reset can subsequently be invoked in the event that the previous conditions cannot be met at power-up.

After the power supply has stabilized the internal POR releases RESETN and an internal pull-up pulls it high, which starts the calibration sequence. If a subsequent user-initiated reset is desired, the RESETN pin should be connected to an open-drain driver with an off-state/high impedance state leakage of less than 0.5mA to assure exit from the reset state so calibration can start.

The calibration sequence is initiated on the rising edge of RESETN, as shown in Figure 23 on page 17. Calibration status can be determined by reading the cal_status bit (LSB) at 0xB6. This bit is '0' during calibration and goes to a logic '1' when calibration is complete. The data outputs output 0xCCCC during calibration; this can also be used to determine calibration status.

While RESETN is low, the output clock (CLKOUTP/CLKOUTN) is set low. Normal operation of the output clock resumes at the next input clock edge (CLKP/CLKN) after RESETN is de-asserted. At 250MSPS the nominal calibration time is 200ms, while the maximum calibration time is 550ms.

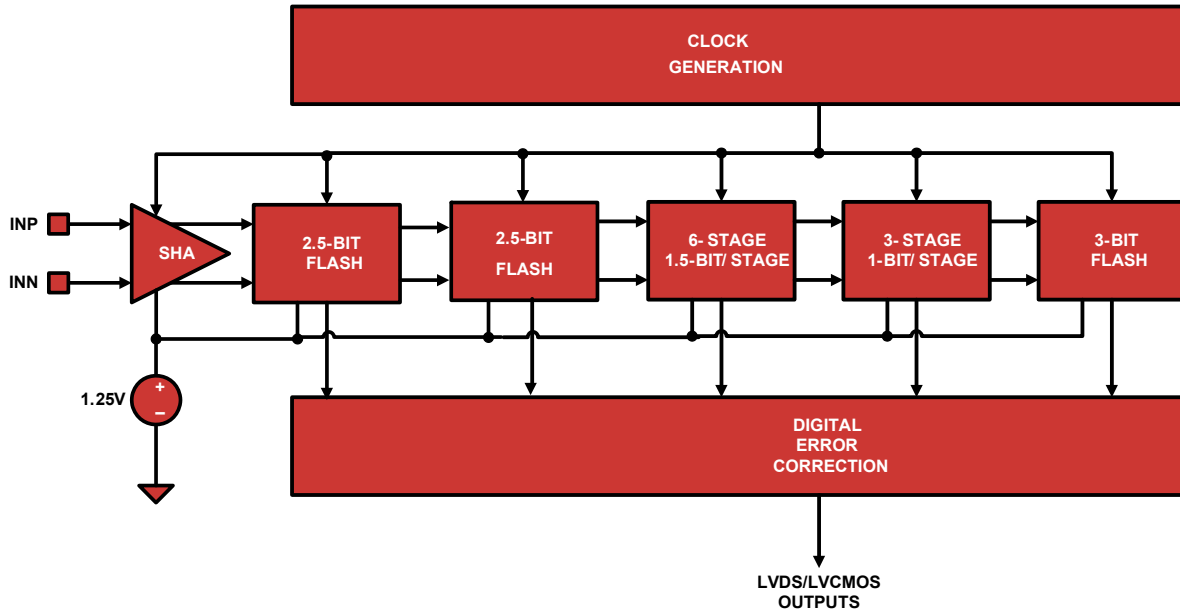

FIGURE 22. A/D CORE BLOCK DIAGRAM

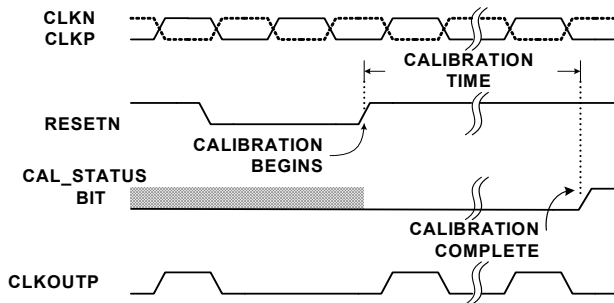

FIGURE 23. CALIBRATION TIMING

User Initiated Reset

Recalibration of the A/D can be initiated at any time by driving the RESETN pin low for a minimum of one clock cycle. An open-drain driver with a drive strength in its high impedance state of less than 0.5mA is recommended, as RESETN has an internal high impedance pull-up to OVDD. As is the case during power-on reset, RESETN and DNC pins must be in the proper state for the calibration to successfully execute.

The performance of the ISLA214P50 changes with variations in temperature, supply voltage or sample rate. The extent of these changes may necessitate recalibration, depending on system performance requirements. Best performance is achieved by recalibrating the A/D under the environmental conditions at which it operates.

A supply voltage variation of less than 100mV generally results in an SNR change of less than 0.5dBFS and SFDR change of less than 3dBc.

In situations where the sample rate is not constant, best results are obtained if the device is calibrated at the highest sample rate. Reducing the sample rate by less than 80MSPS typically results in an SNR change of less than 0.5dBFS and an SFDR change of less than 3dBc.

Figures 24 through 26 on page 18 show the effect of temperature on SNR and SFDR performance with power-on calibration performed at -40°C , $+25^{\circ}\text{C}$, and $+85^{\circ}\text{C}$. Each plot shows the variation of SNR/SFDR across temperature after a single power on calibration at -40°C , $+25^{\circ}\text{C}$, and $+85^{\circ}\text{C}$. Best performance is typically achieved by a user-initiated power-on calibration at the operating conditions, as stated earlier. Applications working across the full temperature range can use the on-chip calibration feature to maximize performance when large temperature variations are expected.

Temperature Calibration

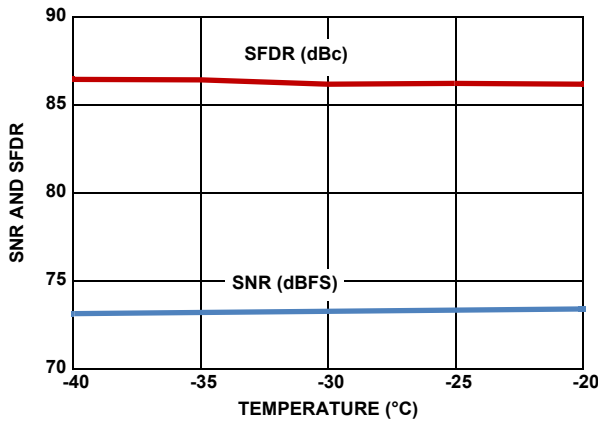

FIGURE 24. TYPICAL SNR, SFDR PERFORMANCE vs TEMPERATURE, DEVICE CALIBRATED AT -40 °C, 500MSPS OPERATION, $f_{IN} = 105\text{MHz}$

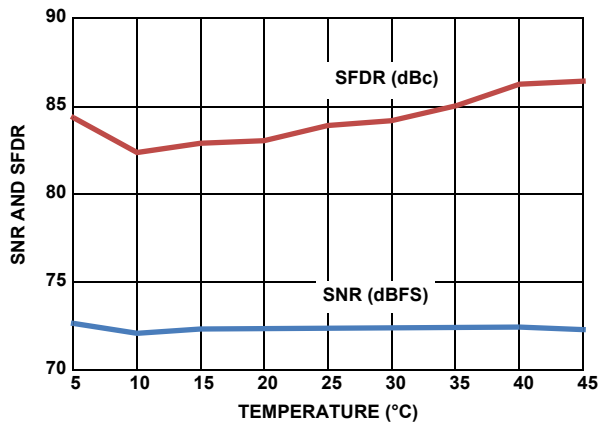

FIGURE 25. TYPICAL SNR, SFDR PERFORMANCE vs TEMPERATURE, DEVICE CALIBRATED AT +25 °C, 500MSPS OPERATION, $f_{IN} = 105\text{MHz}$

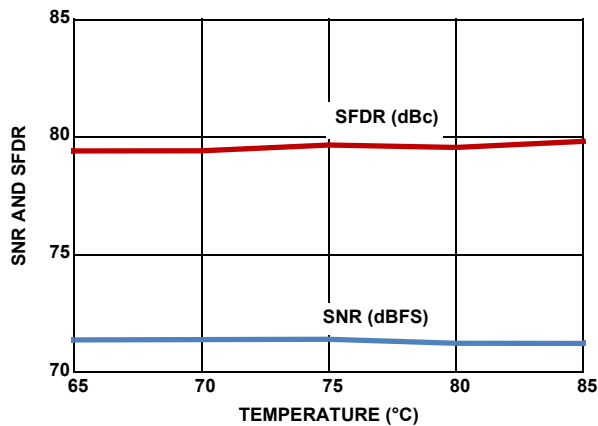

FIGURE 26. TYPICAL SNR, SFDR PERFORMANCE vs TEMPERATURE, DEVICE CALIBRATED AT +85 °C, 500MSPS OPERATION, $f_{IN} = 105\text{MHz}$

Analog Input

A single differential input (VINP/VINN) connects to the Sample and Hold Amplifier (SHA) of each unit A/D. The ideal full-scale input voltage is 2.0V, centered at the VCM voltage of 0.94V as shown in Figure 27.

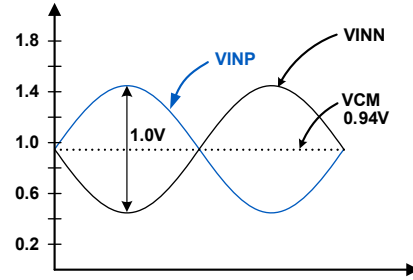

FIGURE 27. ANALOG INPUT RANGE

Best performance is obtained when the analog inputs are driven differentially. The common-mode output voltage, VCM, should be used to properly bias the inputs as shown in Figures 28 through 30. An RF transformer gives the best noise and distortion performance for wideband and/or high intermediate frequency (IF) inputs. Two different transformer input schemes are shown in Figures 28 and 29.

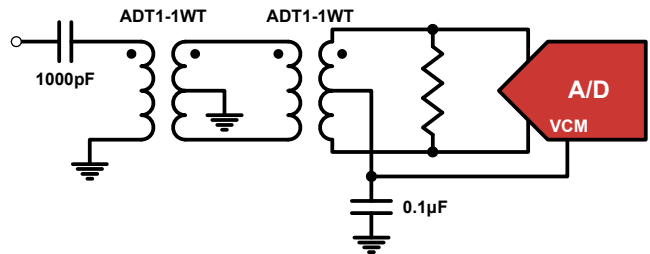

FIGURE 28. TRANSFORMER INPUT FOR GENERAL PURPOSE APPLICATIONS

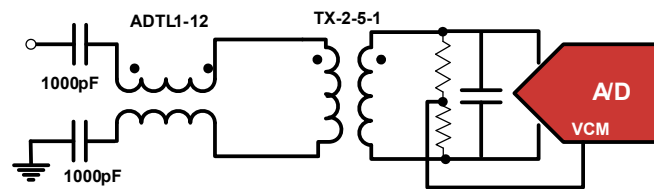

FIGURE 29. TRANSMISSION-LINE TRANSFORMER INPUT FOR HIGH IF APPLICATIONS

This dual transformer scheme is used to improve common-mode rejection, which keeps the common-mode level of the input matched to VCM. The value of the shunt resistor should be determined based on the desired load impedance. The differential input resistance of the ISLA214P50 is 300Ω.

The SHA design uses a switched capacitor input stage (see Figure 43 on page 34), which creates current spikes when the sampling capacitance is reconnected to the input voltage. This causes a disturbance at the input which must settle before the next sampling point. Lower source impedance results in faster settling and improved performance. Therefore, a 1:1 transformer and low shunt resistance are recommended for optimal performance.

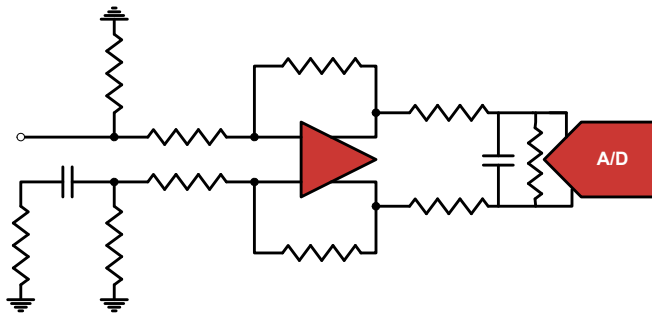

FIGURE 30. DIFFERENTIAL AMPLIFIER INPUT

A differential amplifier, as shown in the simplified block diagram in Figure 30, can be used in applications that require DC-coupling. In this configuration, the amplifier typically dominates the achievable SNR and distortion performance. The ISL552xx differential amplifier family can also be used in certain AC applications with minimal performance degradation. Contact the factory for more information.

Clock Input

The clock input circuit is a differential pair (see Figure 44 on page 34). Driving these inputs with a high level (up to 1.8V_{P-P} on each input) sine or square wave provides the lowest jitter performance. A transformer with 4:1 impedance ratio provides increased drive levels. The clock input is functional with AC-coupled LVDS, LVPECL, and CML drive levels. To maintain the lowest possible aperture jitter, it is recommended to have high slew rate at the zero crossing of the differential clock input signal.

The recommended drive circuit is shown in Figure 31. A duty range of 40% to 60% is acceptable. The clock can be driven single-ended, but this reduces the edge rate and may impact SNR performance. The clock inputs are internally self-biased to AVDD/2 to facilitate AC coupling.

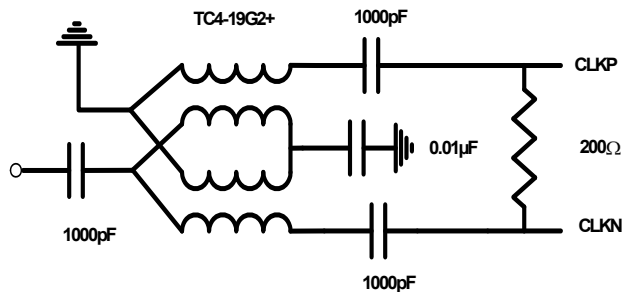

FIGURE 31. RECOMMENDED CLOCK DRIVE

A selectable 2x frequency divider is provided in series with the clock input. The divider can be used in the 2x mode with a sample clock equal to twice the desired sample rate. This allows the use of the Phase Slip feature, which enables synchronization of multiple ADCs. The Phase Slip feature can be used as an alternative to using the CLKDIVRST pins to synchronize ADCs in a multiple ADC system.

TABLE 1. CLKDIV PIN SETTINGS

CLKDIV PIN	DIVIDE RATIO
AVSS	2
Float	1
AVDD	Not Allowed

Jitter

In a sampled data system, clock jitter directly impacts the achievable SNR performance. The theoretical relationship between clock jitter (t_j) and SNR is shown in Equation 1 and is illustrated in Figure 32.

$$SNR = 20 \log_{10} \left(\frac{1}{2\pi f_{IN} t_j} \right) \tag{EQ. 1}$$

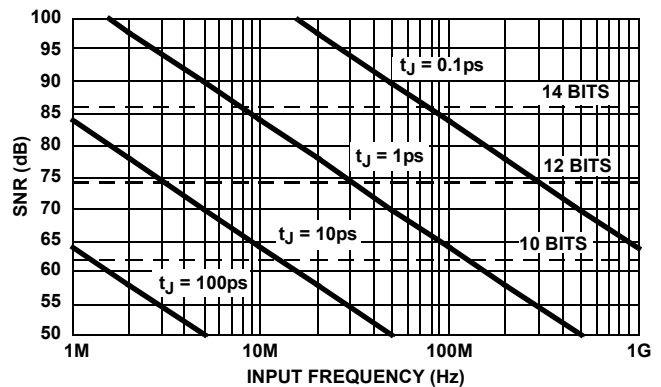

FIGURE 32. SNR vs CLOCK JITTER

This relationship shows the SNR that would be achieved if clock jitter were the only non-ideal factor. In reality, achievable SNR is limited by internal factors such as linearity, aperture jitter, and thermal noise. Internal aperture jitter is the uncertainty in the sampling instant shown in Figure 1A on page 11. The internal aperture jitter combines with the input clock jitter in a root-sum-square fashion, since they are not statistically correlated, and this determines the total jitter in the system. The total jitter, combined with other noise sources, then determines the achievable SNR.

Voltage Reference

A temperature compensated internal voltage reference provides the reference charges used in the successive approximation operations. The full-scale range of each A/D is proportional to the reference voltage. The nominal value of the voltage reference is 1.25V.

Digital Outputs

Output data is available as a parallel bus in LVDS-compatible (default) or CMOS modes. In either case, the data is presented in Double Data Rate (DDR) format. Figures 1A and 1B show the timing relationships for LVDS and CMOS modes, respectively.

Additionally, the drive current for LVDS mode can be set to a nominal 3mA (default) or a power-saving 2mA. The lower current setting can be used in designs where the receiver is in close physical proximity to the A/D. The applicability of this setting is dependent upon the PCB layout, therefore the user should experiment to determine if performance degradation is observed.

The output mode can be controlled through the SPI port, by writing to address 0x73, see [“Serial Peripheral Interface” on page 24](#).

An external resistor creates the bias for the LVDS drivers. A 10kΩ, 1% resistor must be connected from the RLVS pin to OVSS.

Power Dissipation

The power dissipated by the ISLA214P50 is primarily dependent on the sample rate and the output modes: LVDS vs CMOS and DDR vs SDR. There is a static bias in the analog supply, while the remaining power dissipation is linearly related to the sample rate. The output supply dissipation changes to a lesser degree in LVDS mode, but is more strongly related to the clock frequency in CMOS mode.

Nap/Sleep

Portions of the device can be shut down to save power during times when operation of the A/D is not required. Two power saving modes are available: Nap and Sleep. Nap mode reduces power dissipation to less than 104mW. Sleep mode reduces power dissipation to less than 19mW.

All digital outputs (Data, CLKOUT, and OR) are placed in a high impedance state during Nap or Sleep. The input clock should remain running and at a fixed frequency during Nap or Sleep and CSB should be high. Recovery time from Nap mode increases if the clock is stopped, since the internal DLL can take up to 52μs to regain lock at 500MSPS.

By default after the device is powered on, the operational state is controlled by the NAPSLP pin as shown in [Table 2](#).

TABLE 2. NAPSLP PIN SETTINGS

NAPSLP PIN	MODE
AVSS	Normal
Float	Sleep
AVDD	Nap

The power-down mode can also be controlled through the SPI port, which overrides the NAPSLP pin setting. Details are shown in [“Serial Peripheral Interface” on page 24](#).

Data Format

Output data can be presented in three formats: two’s complement (default), Gray code, and offset binary. The data format can also be controlled through the SPI port, by writing to address 0x73. Details are shown in [“Serial Peripheral Interface” on page 24](#).

Offset binary coding maps the most negative input voltage to code 0x000 (all zeros) and the most positive input to 0xFFFF (all ones). Two’s complement coding simply complements the MSB of the offset binary representation.

When calculating Gray code the MSB is unchanged. The remaining bits are computed as the XOR of the current bit position and the next most significant bit. [Figure 33](#) shows this operation.

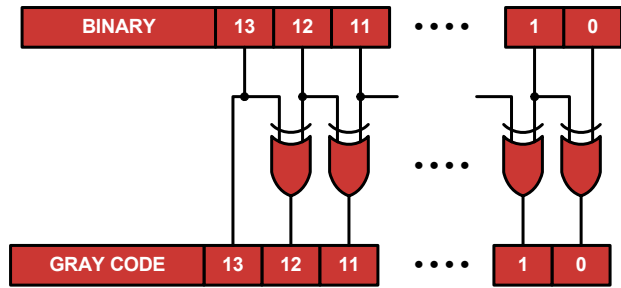

FIGURE 33. BINARY TO GRAY CODE CONVERSION

Converting back to offset binary from Gray code must be done recursively, using the result of each bit for the next lower bit as shown in [Figure 34](#).

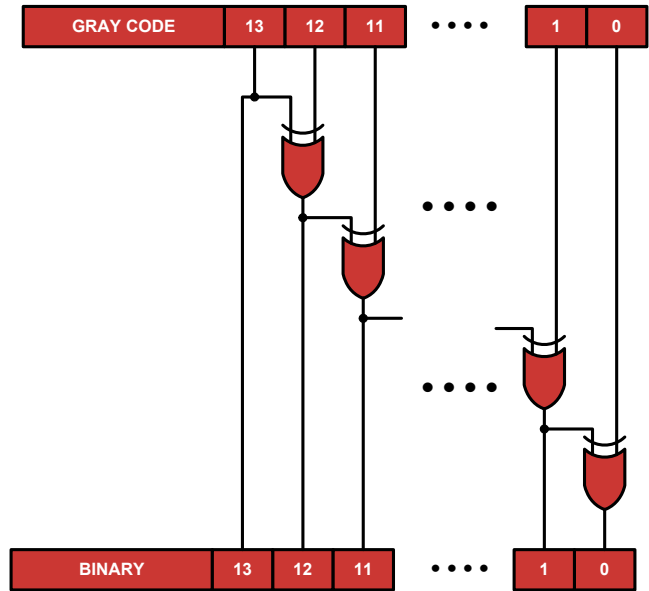

FIGURE 34. GRAY CODE TO BINARY CONVERSION

Mapping of the input voltage to the various data formats is shown in [Table 3](#).

TABLE 3. INPUT VOLTAGE TO OUTPUT CODE MAPPING

INPUT VOLTAGE	OFFSET BINARY	TWO’S COMPLEMENT	GRAY CODE
-Full Scale	00 0000 0000 0000	10 0000 0000 0000	00 0000 0000 0000
-Full Scale + 1LSB	00 0000 0000 0001	10 0000 0000 0001	00 0000 0000 0001
Mid-Scale	10 0000 0000 0000	00 0000 0000 0000	11 0000 0000 0000
+Full Scale - 1LSB	11 1111 1111 1110	01 1111 1111 1110	10 0000 0000 0001
+Full Scale	11 1111 1111 1111	01 1111 1111 1111	10 0000 0000 0000

I2E Requirements and Restrictions

Overview

I2E is a blind and background capable algorithm, designed to transparently eliminate interleaving artifacts. This circuitry eliminates interleave artifacts due to offset, gain, and sample time mismatches between unit A/Ds, and across supply voltage and temperature variations in real-time.

Differences in the offset, gain, and sample times of time-interleaved A/Ds create artifacts in the digital outputs. Each of these artifacts creates a unique signature that may be detectable in the captured samples. The I2E algorithm optimizes performance by detecting error signatures and adjusting each unit A/D using minimal additional power.

I2E calibration is off by default at power-up. The I2E algorithm can be put in Active Run state using SPI. When the I2E algorithm is in Active Run state, it detects and corrects for offset, gain, and sample time mismatches in real time (see Track mode description under "Active Run State" on page 21). However, certain analog input characteristics can obscure the estimation of these mismatches. The I2E algorithm is capable of detecting these obscuring analog input characteristics, and as long as they are present I2E stops updating the correction in real time. Effectively, this freezes the current correction circuitry to the last known-good state (see Hold mode description in the "Active Run State" section). Once the analog input signal stops obscuring the interleaved artifacts, the I2E algorithm automatically starts correcting for mismatch in real time again.

Active Run State

During the Active Run state the I2E algorithm actively suppresses artifacts due to interleaving based on statistics in the digitized data. I2E has two modes of operation in this state (described in the following), dynamically chosen in real-time by the algorithm based on the statistics of the analog input signal.

1. Track mode refers to the default state of the algorithm, when all artifacts due to interleaving are actively being eliminated. To be in Track mode the analog input signal to the device must adhere to the following requirements:

Possess total power greater than -20dBFS, integrated from 1MHz to Nyquist but excluding signal energy in a 100kHz band centered at $f_S/4$

The criteria above assumes 500MSPS operation; the frequency bands should be scaled proportionally for lower sample rates. Note that the effect of excluding energy in the 100kHz band around of $f_S/4$ exists in every Nyquist zone. This band generalizes to the form $(N \cdot f_S/4 - 50\text{kHz})$ to $(N \cdot f_S/4 + 50\text{kHz})$, where N is any odd integer. An input signal that violates these criteria briefly (approximately 10 μ s), before and after which it meets this criteria, does not impact system performance.

The algorithm must be in Track mode for approximately one second (defined as IEpst_t on "I2E Specifications" on page 10) after power-up before the specifications apply. Once this requirement has been met, the specifications of the device continue to be met while I2E

remains in Track mode, even in the presence of temperature and supply voltage changes.

2. Hold mode refers to the state of the I2E algorithm when the analog input signal does not meet the requirements specified above. If the algorithm detects that the signal no longer meets the criteria, it automatically enters Hold mode. In Hold mode, the I2E circuitry freezes the adjustment values based on the most recent set of valid input conditions. However, in Hold mode, the I2E circuitry does not correct for new changes in interleave artifacts induced by supply voltage and temperature changes. The I2E circuitry remains in Hold mode until such time as the analog input signal meets the requirements for Track mode.

Power Meter

The power meter calculates the average power of the analog input, and determines if it's within range to allow operation in Track mode. Both AC RMS and total RMS power are calculated, and there are separate SPI programmable thresholds and hysteresis values for each.

FS/4 Filter

A digital filter removes the signal energy in a 100kHz band around $f_S/4$ before the I2E circuitry uses these samples for estimating offset, gain, and sample time mismatches (data samples produced by the A/D are unaffected by this filtering). This allows the I2E algorithm to continue in Active Run state while in the presence of a large amount of input energy near the $f_S/4$ frequency. This filter can be powered down if it's known that the signal characteristics won't violate the restrictions. Powering down the FS/4 filter reduces power consumption by approximately 30mW.

Nyquist Zones

The I2E circuitry allows the use of any one Nyquist zone without configuration, but requires the use of only one Nyquist zone. Inputs that switch dynamically between Nyquist zones causes poor performance for the I2E circuitry. For example, I2E functions properly for a particular application that has $f_S = 500\text{MSPS}$ and uses the 1st Nyquist zone (0MHz to 250MHz). I2E also functions properly for an application that uses $f_S = 500\text{MSPS}$ and the 2nd Nyquist zone (250MHz to 500MHz). I2E does not function properly for an application that uses $f_S = 500\text{MSPS}$, and input frequency bands from 150MHz to 210MHz and 250MHz to 290MHz simultaneously. There is no need to configure the I2E algorithm to use a particular Nyquist zone, but no dynamic switching between Nyquist zones is permitted while I2E is running.

Configurability and Communication

I2E can respond to status queries, be turned on and turned off, and generally configured using SPI programmable registers. Configuring of I2E is generally unnecessary unless the application cannot meet the requirements of Track mode on or after power up. Parameters that can be adjusted and read back include FS/4 filter threshold and status, Power Meter threshold and status, and initial values for the offset, gain, and sample time values to use when I2E starts.

Clock Divider Synchronous Reset

An output clock (CLKOUTP, CLKOUTN) is provided to facilitate latching of the sampled data. This clock is at half the frequency of the sample clock, and the absolute phase of the output clocks for multiple A/Ds is indeterminate. This feature allows the phase of multiple A/Ds to be synchronized (see Figure 35), which greatly simplifies data capture in systems employing multiple A/Ds.

The reset signal must be well-timed with respect to the sample clock (see “Switching Specifications” Table on page 12).

A 100Ω differential termination resistor must be supplied between CLKDIVRSTP and CLKDIVRSTN, external to the ADC, (on the PCB) and should be located as close to the CLKDIVRSTP/N pins as possible.

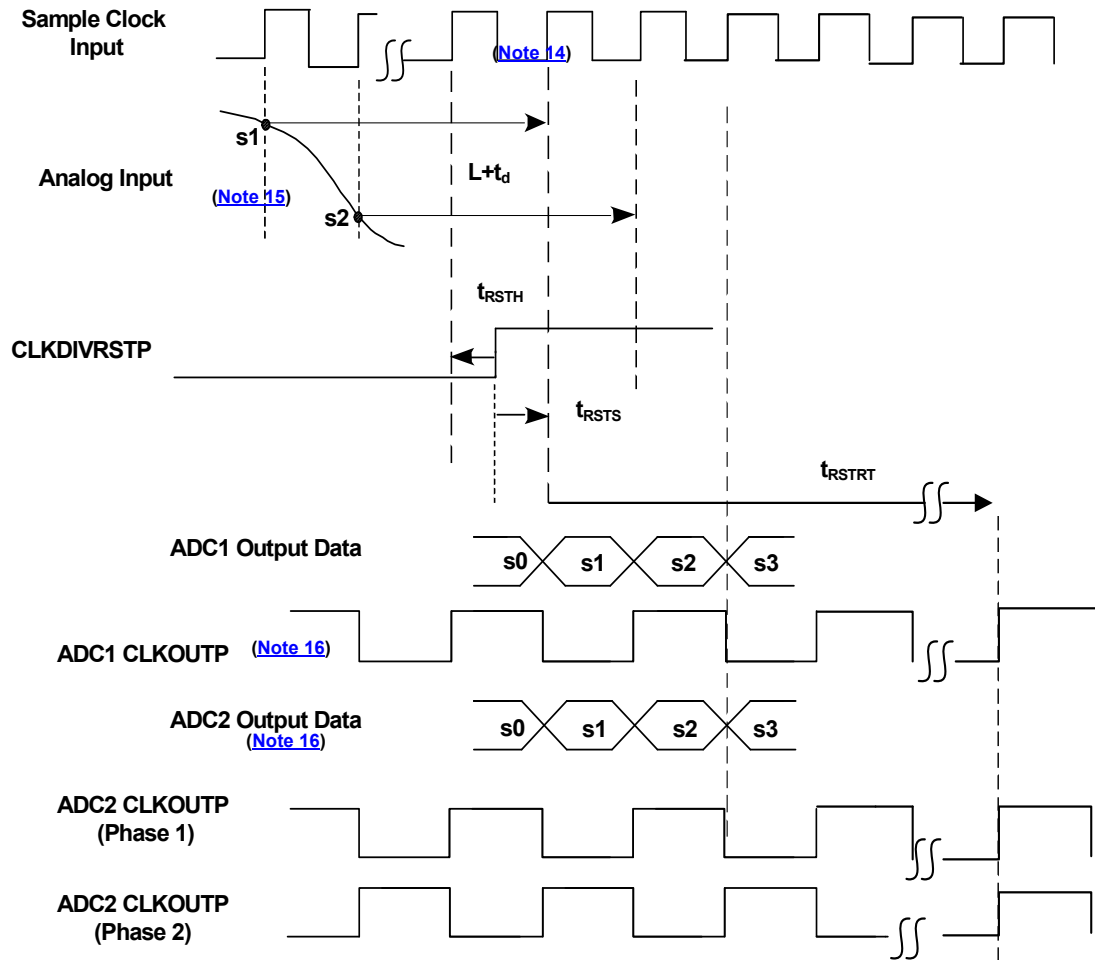

FIGURE 35. SYNCHRONOUS RESET OPERATION

NOTES:

- 14. Delay equals fixed pipeline latency (L cycles) plus fixed analog propagation delay t_d .
- 15. CLKDIVRSTP setup and hold times are with respect to input sample clock rising edge. CLKDIVRSTN is not shown, but must be driven, and is the compliment of CLKDIVRSTP.
- 16. Either Output Clock Phase (Phase 1 or Phase 2) equally likely prior to synchronization.

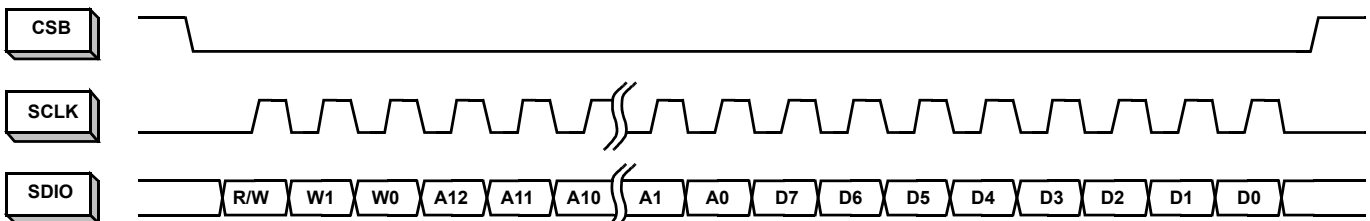

FIGURE 36. MSB-FIRST ADDRESSING

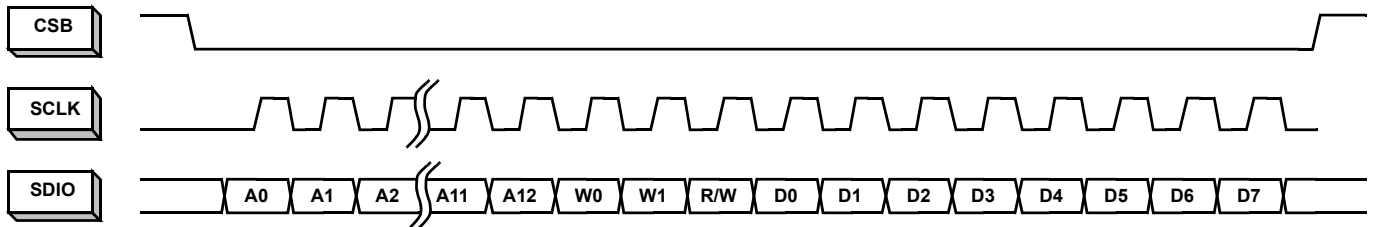
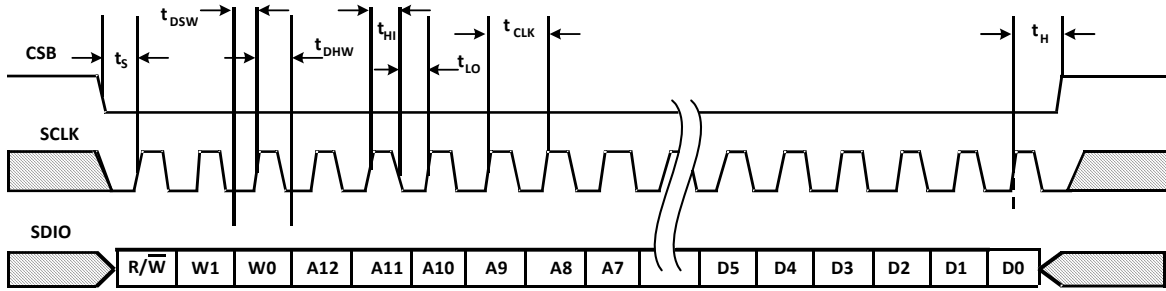

FIGURE 37. LSB-FIRST ADDRESSING



SPI WRITE

FIGURE 38. SPI WRITE

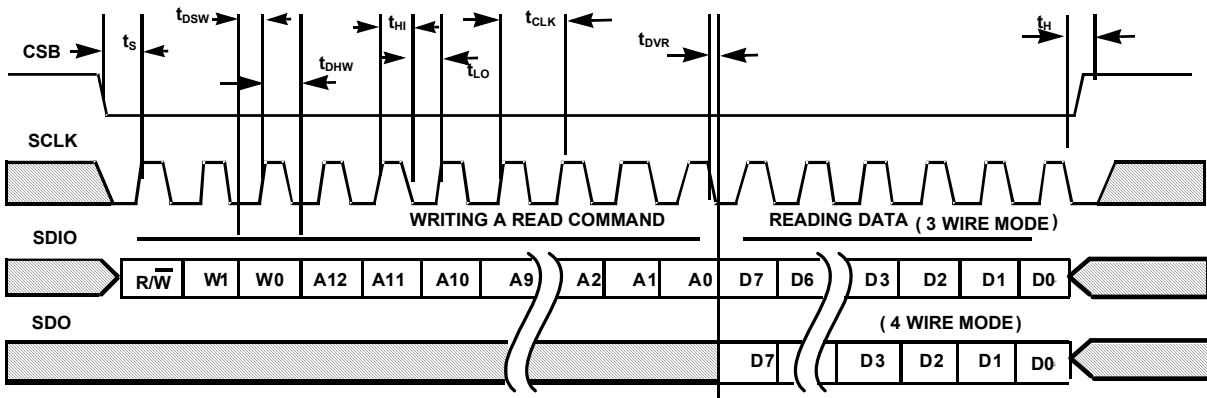

FIGURE 39. SPI READ

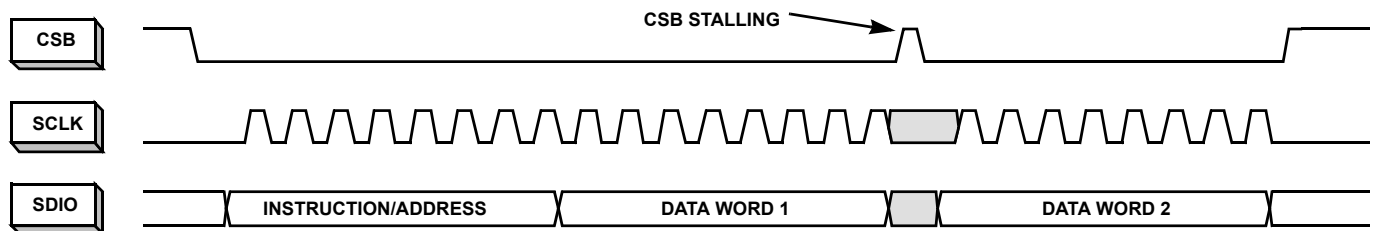

FIGURE 40. 2-BYTE TRANSFER

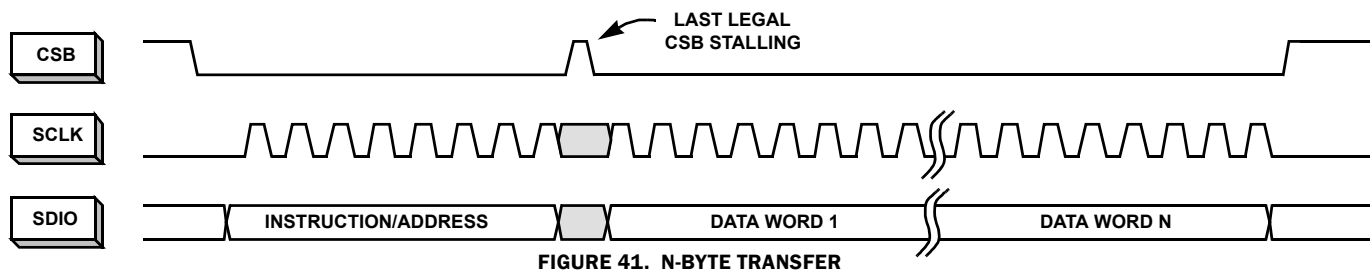

FIGURE 41. N-BYTE TRANSFER

Serial Peripheral Interface

A Serial Peripheral Interface (SPI) bus is used to facilitate configuration of the device and to optimize performance. The SPI bus consists of Chip Select (CSB), Serial Clock (SCLK) Serial Data Output (SDO), and Serial Data Input/Output (SDIO). The maximum SCLK rate is equal to the A/D sample rate (f_{SAMPLE}) divided by 32 for both write operations and read operations. At $f_{\text{SAMPLE}} = 500\text{MHz}$, maximum SCLK is 15.63MHz for writing and read operations. There is no minimum SCLK rate.

The following sections describe various registers that are used to configure the SPI or adjust performance or functional parameters. Many registers in the available address space (0x00 to 0xFF) are not defined in this document. Additionally, within a defined register there may be certain bits or bit combinations that are reserved. Undefined registers and undefined values within defined registers are reserved and should not be selected. Setting any reserved register or value may produce indeterminate results.

SPI Physical Interface

The SCLK pin provides synchronization for the data transfer. By default, all data is presented on the SDIO pin in three-wire mode. The state of the SDIO pin is set automatically in the communication protocol (described in the following). A dedicated SDO pin can be activated by setting 0x00[7] high to allow operation in four-wire mode.

The SPI port operates in a half duplex master/slave configuration, with the ISLA214P50 functioning as a slave. Multiple slave devices can interface to a single master in three-wire mode only, since the SDO output of an unaddressed device is asserted in four wire mode.

The CSB pin determines when a slave device is being addressed. Multiple slave devices can be written to concurrently, but only one slave device can be read from at a given time (again, only in three-wire mode). If multiple slave devices are selected for reading at the same time, the results are indeterminate.

The communication protocol begins with an instruction/address phase. The first rising SCLK edge following a high to low transition on CSB determines the beginning of the two-byte instruction/address command; SCLK must be static low before the CSB transition. Data can be presented in MSB-first order or LSB-first order. The default is MSB-first, but this can be changed by setting 0x00[6] high. Figures 36 and 37 on page 23 show the appropriate bit ordering for the MSB-first and LSB-first modes, respectively. In MSB-first mode, the address is incremented for multi-byte transfers, while in LSB-first mode it is decremented.

In the default mode, the MSB is R/W, which determines if the data is to be read (active high) or written. The next two bits, W1 and W0, determine the number of data bytes to be read or written (see Table 4). The lower 13 bits contain the first address for the data transfer. This relationship is illustrated in Figure 38, and timing values are given in “Switching Specifications” on page 12.

After the instruction/address bytes have been read, the appropriate number of data bytes are written to or read from the A/D (based on the R/W bit status). The data transfer continues as long as CSB remains low and SCLK is active. Stalling of the CSB pin is allowed at any byte boundary (instruction/address or data) if the number of bytes being transferred is three or less. For transfers of four bytes or more, CSB is allowed to stall in the middle of the instruction/address bytes or before the first data byte. If CSB transitions to a high state after that point the state machine resets and terminates the data transfer.

TABLE 4. BYTE TRANSFER SELECTION

[W1:W0]	BYTES TRANSFERRED
00	1
01	2
10	3
11	4 or more

Figures 40 and 41 illustrate the timing relationships for 2-byte and N-byte transfers, respectively. The operation for a 3-byte transfer can be inferred from these diagrams.

SPI Configuration

ADDRESS 0X00: CHIP_PORT_CONFIG

Bit ordering and SPI reset are controlled by this register. Bit order can be selected as MSB to LSB (MSB first) or LSB to MSB (LSB first) to accommodate various microcontrollers.

Bit 7 SDO Active

Bit 6 LSB First

Setting this bit high configures the SPI to interpret serial data as arriving in LSB to MSB order.

Bit 5 Soft Reset

Setting this bit high resets all SPI registers to default values.

Bit 4 Reserved

This bit should always be set high.

Bits 3:0 These bits should always mirror Bits 4:7 to avoid ambiguity in bit ordering.

ADDRESS 0X02: BURST_END

If a series of sequential registers are to be set, Burst mode can improve throughput by eliminating redundant addressing. Setting the burst_end address determines the end of the transfer; during a write operation, the user must be cautious to transmit the correct number of bytes based on the starting and ending addresses.

Bits 7:0 Burst End Address

This register value determines the ending address of the burst data.

Device Information**ADDRESS 0X08: CHIP_ID****ADDRESS 0X09: CHIP_VERSION**

The generic die identifier and a revision number, respectively, can be read from these two registers.

Device Configuration/Control

A common SPI map, which can accommodate single-channel or multi-channel devices, is used for all Renesas A/D products.

ADDRESS 0X20: OFFSET_COARSE_ADC0**ADDRESS 0X21: OFFSET_FINE_ADC0**

The input offset of the A/D core can be adjusted in fine and coarse steps. Both adjustments are made via an 8-bit word as detailed in [Table 5](#). The data format is twos complement.

The default value of each register is the result of the self-calibration after initial power-up. If a register is to be incremented or decremented, the user should first read the register value then write the incremented or decremented value back to the same register. Bit 0 in register 0xFE must be set high to enable updates written to 0x20 and 0x21 to be used by the ADC (see description for ["ADDRESS 0XFE: OFFSET/GAIN_ADJUST_ENABLE"](#) on [page 29](#)).

TABLE 5. OFFSET ADJUSTMENTS

PARAMETER	0x20[7:0] COARSE OFFSET	0x21[7:0] FINE OFFSET
Steps	255	255
-Full Scale (0x00)	-133LSB (-47mV)	-5LSB (-1.75mV)
Mid-Scale (0x80)	0.0LSB (0.0mV)	0.0LSB
+Full Scale (0xFF)	+133LSB (+47mV)	+5LSB (+1.75mV)
Nominal Step Size	1.04LSB (0.37mV)	0.04LSB (0.014mV)

ADDRESS 0X22: GAIN_COARSE_ADC0**ADDRESS 0X23: GAIN_MEDIUM_ADC0****ADDRESS 0X24: GAIN_FINE_ADC0**

Gain of the A/D core can be adjusted in coarse, medium and fine steps. Coarse gain is a 4-bit adjustment while medium and fine are 8-bit. Multiple Coarse Gain Bits can be set for a total adjustment range of $\pm 4.2\%$. ('0011' $\cong -4.2\%$ and '1100' $\cong +4.2\%$) It is recommended to use one of the coarse gain settings (-4.2%, -2.8%, -1.4%, 0, 1.4%, 2.8%, 4.2%) and fine-tune the gain using the registers at 23h and 24h.

The default value of each register is the result of the self-calibration after initial power-up. If a register is to be

incremented or decremented, the user should first read the register value then write the incremented or decremented value back to the same register. Bit 0 in register 0xFE must be set high to enable updates written to 0x26 and 0x27 to be used by the ADC (see description for ["ADDRESS 0XFE: OFFSET/GAIN_ADJUST_ENABLE"](#)).

TABLE 6. COARSE GAIN ADJUSTMENT

0x22[3:0] core 0 0x26[3:0] core 1	NOMINAL COARSE GAIN ADJUST (%)
Bit3	+2.8
Bit2	+1.4
Bit1	-2.8
Bit0	-1.4

TABLE 7. MEDIUM AND FINE GAIN ADJUSTMENTS

PARAMETER	0x23[7:0] MEDIUM GAIN	0x24[7:0] FINE GAIN
Steps	256	256
-Full Scale (0x00)	-2%	-0.20%
Mid-Scale (0x80)	0.00%	0.00%
+Full Scale (0xFF)	+2%	+0.2%
Nominal Step Size	0.016%	0.0016%

ADDRESS 0X25: MODES

Two distinct reduced power modes can be selected. By default, the tri-level NAPSLP pin can select normal operation, Nap or Sleep modes (refer to ["Nap/Sleep"](#) on [page 20](#)). This functionality can be overridden and controlled through the SPI. This is an indexed function when controlled from the SPI, but a global function when driven from the pin. This register is not changed by a Soft Reset.

TABLE 8. POWER-DOWN CONTROL

VALUE	0x25[2:0] POWER DOWN MODE
000	Pin Control
001	Normal Operation
010	Nap Mode
100	Sleep Mode

ADDRESS 0X26: OFFSET_COARSE_ADC1**ADDRESS 0X27: OFFSET_FINE_ADC1**

The input offset of A/D core#1 can be adjusted in fine and coarse steps in the same way that offset for core#0 can be adjusted. Both adjustments are made via an 8-bit word as detailed in [Table 5](#). The data format is twos complement.

The default value of each register is the result of the self-calibration after initial power-up. If a register is to be incremented or decremented, the user should first read the register value then write the incremented or decremented value back to the same register. Bit 0 in register 0xFE must be set high to enable updates written to 0x26 and 0x27 to be used by the ADC (see description for 0xFE).

ADDRESS 0X28: GAIN_COARSE__ADC1**ADDRESS 0X29: GAIN_MEDIUM_ADC1****ADDRESS 0X2A: GAIN_FINE_ADC1**

Gain of A/D core #1 can be adjusted in coarse, medium and fine steps in the same way that core #0 can be adjusted. Coarse gain is a 4-bit adjustment while medium and fine are 8-bit. Multiple Coarse Gain Bits can be set for a total adjustment range of ± 4.2 . Bit 0 in register 0xFE must be set high to enable updates written to 0x29 and 0x2A to be used by the ADC (see description for ["ADDRESS 0xFE: OFFSET/GAIN_ADJUST_ENABLE" on page 29](#)).

ADDRESS 0X30: I2E STATUS

The I2E general status register.

Bits 0 and 1 indicate if the I2E circuitry is in Active Run or Hold state. The state of the I2E circuitry is dependent on the analog input signal itself. If the input signal obscures the interleave mismatched artifacts such that I2E cannot estimate the mismatch, the algorithm dynamically enters the Hold state. For example, a DC mid-scale input to the A/D does not contain sufficient information to estimate the gain and sample time skew mismatches, and therefore the I2E algorithm enters the Hold state. In the Hold state, the analog adjustments for interleave correction are frozen and mismatch estimate calculations cease until such time as the analog input achieves sufficient quality to allow the I2E algorithm to make mismatch estimates again.

Bit 0: 0 = I2E has not detected a low power condition. 1 = I2E has detected a low power condition, and the analog adjustments for interleave correction are frozen.

Bit 1: 0 = I2E has not detected a low AC power condition. 1 = I2E has detected a low AC power condition, and I2E continues to correct with best known information but does not update its interleave correction adjustments until the input signal achieves sufficient AC RMS power.

Bit 2: When first started, the I2E algorithm can take a significant amount of time to settle (~1s), dependent on the characteristics of the analog input signal. 0 = I2E is still settling, 1 = I2E has completed settling.

ADDRESS 0X31: I2E CONTROL

The I2E general control register. This register can be written while I2E is running to control various parameters.

Bit 0: 0 = turn I2E off, 1 = turn I2E on

Bit 1: 0 = no action, 1 = freeze I2E, leaving all settings in the current state. Subsequently writing a 0 to this bit allows I2E to continue from the state it was left in.

Bit 2-4: Disable any of the interleave adjustments of offset, gain, or sample time skew

Bit 5: 0 = bypass notch filter, 1 = use notch filter on incoming data before estimating interleave mismatch terms

ADDRESS 0X32: I2E STATIC CONTROL

The I2E general static control register. This register must be written prior to turning I2E on for the settings to take effect.

Bit 1-4: Reserved, always set to 0

Bit 5: 0 = normal operation, 1 = skip coarse adjustment of the offset, gain, and sample time skew analog controls when I2E is first turned on. This bit would typically be used if optimal analog adjustment values for offset, gain, and sample time skew have been preloaded in order to have the I2E algorithm converge more quickly.

The system gain of the pair of interleaved core A/Ds can be set by programming the medium and fine gain of the reference A/D before turning I2E on. In this case, I2E adjusts the non-reference A/D's gain to match the reference A/D's gain.

Bit 7: Reserved, always set to 0

ADDRESS 0X4A: I2E POWER DOWN

This register provides the capability to completely power down the I2E algorithm and the Notch filter. This would typically be done to conserve power.

BIT 0: Power down the I2E algorithm

BIT 1: Power down the Notch Filter

ADDRESS 0X50-0X55: I2E FREEZE THRESHOLDS

This group of registers provides programming access to configure I2E's dynamic freeze control. As with any interleave mismatch correction algorithm making estimates of the interleave mismatch errors using the digitized application input signal, there are certain characteristics of the input signal that can obscure the mismatch estimates. For example, a DC input to the A/D contains no information about the sample time skew mismatch between the core A/Ds, and thus should not be used by the I2E algorithm to update its sample time skew estimate. Under such circumstances, I2E enters Hold state. In the Hold state, the analog adjustments are frozen and mismatch estimate calculations cease until such time as the analog input achieves sufficient quality to allow the I2E algorithm to make mismatch estimates again.

These registers allow the programming of the thresholds of the meters used to determine the quality of the input signal. This can be used by the application to optimize I2E's behavior based on knowledge of the input signal. For example, if a specific application had an input signal that was typically 30dB down from full scale, and was primarily concerned about analog performance of the A/D at this input power, lowering the RMS power threshold would allow I2E to continue tracking with this input power level, thus allowing it to track over voltage and temperature changes.

0x50 (LSBs), 0x51 (MSBs) RMS Power Threshold

This 16-bit quantity is the RMS power threshold at which I2E enters Hold state. The RMS power of the analog input is calculated continuously by I2E on incoming data.

Only the upper 12 bits of the ADC sample outputs are used in the averaging process for comparison to the power threshold registers. A 12-bit number squared produces a 24-bit result (for A/D resolutions under 12-bits, the A/D samples are MSB-aligned to 12-bit data). A dynamic number of these 24-bit results are averaged to compare with this threshold approximately every 1 μ s to decide whether or not to freeze I2E. The 24-bit threshold is constructed with Bits 23 through 20 (MSBs) assigned to 0, Bits 19 through 4 assigned to this 16-bit quantity, and Bits 3 through 0 (LSBs) assigned to 0. As an example, if the application wanted

to set this threshold to trigger near the RMS analog input of a -20dBFS sinusoidal input, the calculation to determine this register's value would be:

$$\text{RMS}_{\text{codes}} = \frac{\sqrt{2}}{2} \times 10^{\left(\frac{-20}{20}\right)} \times 2^{12} @ (290)\text{codes} \quad (\text{EQ. 2})$$

$$\text{hex}(((290))^2) = 0x14884_{\text{TruncateMSB and LSB hex digit}} = 0x1488 \quad (\text{EQ. 3})$$

Therefore, programming 0x1488 into these two registers causes I2E to freeze when the signal being digitized has less RMS power than a -20dBFS sinusoid.

The default value of this register is 0x1000, causing I2E to freeze when the input amplitude is less than -21.2 dBFS.

The freezing of I2E by the RMS power meter threshold affects the gain and sample time skew interleave mismatch estimates, but not the offset mismatch estimate.

0x52 RMS Power Hysteresis

In order to prevent I2E from constantly oscillating between the Hold and Track state, there is hysteresis in the comparison described above. After I2E enters a frozen state, the RMS input power must achieve threshold value + hysteresis to again enter the Track state. The hysteresis quantity is a 24-bit value, constructed with Bits 23 through 12 (MSBs) being assigned to 0, Bits 11 through 4 assigned to this register's value, and Bits 3 through 0 (LSBs) assigned to 0.

0x53 (LSBs), 0x54 (MSBs) AC RMS POWER THRESHOLD

Similar to RMS power threshold, there must be sufficient AC RMS power (or dV/dt) of the input signal to measure sample time skew mismatch for an arbitrary input. This is clear from observing the effect when a high voltage (and therefore large RMS value) DC input is applied to the A/D input. Without sufficient dV/dt in the input signal, no information about the sample time skew between the core A/Ds can be determined from the digitized samples. The AC RMS Power Meter is implemented as a high-passed (via DSP) RMS power meter.

The required algorithm is documented as follows.

1. Write the MSBs of the 16-bit quantity to SPI Address 0x54.
2. Write the LSBs of the 16-bit quantity to SPI Address 0x53.

Only the upper 12 bits of the ADC sample outputs are used in the averaging process for comparison to the power threshold registers. A 12-bit number squared produces a 24-bit result (for A/D resolutions under 12-bits, the A/D samples are MSB-aligned to 12-bit data). A dynamic number of these 24-bit results are averaged to compare with this threshold approximately every $1\mu\text{s}$ to decide whether or not to freeze I2E. The 24-bit threshold is constructed with Bits 23 through 20 (MSBs) assigned to 0, Bits 19 through 4 assigned to this 16-bit quantity, and Bits 3 through 0 (LSBs) assigned to 0. The calculation methodology to set this register is identical to the description in the RMS power threshold description.

The freezing of I2E when the AC RMS power meter threshold is not met affects the sample time skew interleave mismatch estimate, but not the offset or gain mismatch estimates.

0x55 AC RMS Power Hysteresis

In order to prevent I2E from constantly oscillating between the Hold and Track state, there is hysteresis in the comparison described above. After I2E enters a frozen state, the AC RMS input power must achieve threshold value + hysteresis to again enter the Track state. The hysteresis quantity is a 24-bit value, constructed with Bits 23 through 12 (MSBs) being assigned to 0, Bits 11 through 4 assigned to this register's value, and Bits 3 through 0 (LSBs) assigned to 0.

Address 0x60-0x64: I2E Initialization

These registers provide access to the initialization values for each of offset, gain, and sample time skew that I2E programs into the target core A/D before adjusting to minimize interleave mismatch. They can be used by the system to, for example, reduce the convergence time of the I2E algorithm by programming in the optimal values before turning I2E on. In this case, I2E only needs to adjust for temperature and voltage-induced changes since the optimal values were recorded.

Global Device Configuration/Control

ADDRESS 0x70: SKEW_DIFF

The value in the skew_diff register adjusts the timing skew between the two A/D cores. The nominal range and resolution of this adjustment are given in [Table 9](#). The default value of this register after power-up is 80h.

TABLE 9. DIFFERENTIAL SKEW ADJUSTMENT

PARAMETER	0x70[7:0] DIFFERENTIAL SKEW
Steps	256
-Full Scale (0x00)	-6.5ps
Mid-Scale (0x80)	0.0ps
+Full Scale (0xFF)	+6.5ps
Nominal Step Size	51fs

ADDRESS 0x71: PHASE_SLIP

The output data clock is generated by dividing down the A/D input sample clock. Some systems with multiple A/Ds can more easily latch the data from each A/D by controlling the phase of the output data clock. This control is accomplished through the use of the phase_slip SPI feature, which allows the rising edge of the output data clock to be advanced by one input clock period, as shown in the [Figure 42](#). Execution of a phase_slip command is accomplished by first writing a '0' to Bit 0 at address 0x71, followed by writing a '1' to Bit 0 at address 0x71.

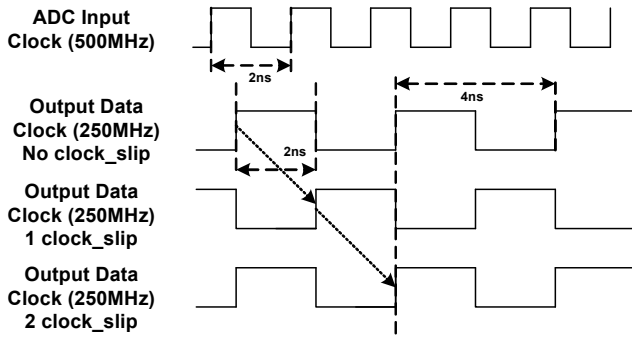

FIGURE 42. PHASE SLIP

ADDRESS 0X72: CLOCK_DIVIDE

The ISLA214P50 has a selectable clock divider that can be set to divide by two or one (no division). By default, the tri-level CLKDIV pin selects the divisor. This functionality can be overridden and controlled through the SPI, as shown in [Table 10](#). This register is not changed by a soft reset.

TABLE 10. CLOCK DIVIDER SELECTION

VALUE	0x72[2:0] CLOCK DIVIDER
000	Pin Control
001	Divide by 1
010	Divide by 2
other	Not Allowed

ADDRESS 0X73: OUTPUT_MODE_A

The output_mode_A register controls the physical output format of the data, as well as the logical coding. The ISLA214P50 can present output data in two physical formats: LVDS (default) or LVCMOS. Additionally, the drive strength in LVDS mode can be set high (default, 3mA) or low (2mA).

Data can be coded in three possible formats: two's complement (default), Gray code or offset binary, see [Table 12](#).

This register is not changed by a Soft Reset.

TABLE 11. OUTPUT MODE CONTROL

VALUE	0x73[7:5] OUTPUT MODE
000	LVDS 3mA (Default)
001	LVDS 2mA
100	LVCMOS

TABLE 12. OUTPUT FORMAT CONTROL

VALUE	0x73[2:0] OUTPUT FORMAT
000	Two's Complement (Default)
010	Gray Code
100	Offset Binary

ADDRESS 0X74: OUTPUT_MODE_B**Bit 6 DLL Range**

This bit sets the DLL operating range to fast (default) or slow.

Internal clock signals are generated by a delay-locked loop (DLL), which has a finite operating range. [Table 13](#) shows the allowable sample rate ranges for the slow and fast settings. Note that Bit 4 at 0x74 is reserved and must not change value. A user writing to Bit 6 should first read 0x74 to determine proper value to write back to Bit 4 when writing to 0x74.

TABLE 13. DLL RANGES

DLL RANGE	MIN	MAX	UNIT
Slow	80	200	MSPS
Fast	160	500	MSPS

ADDRESS 0XB6: CALIBRATION STATUS

The LSB at address 0xB6 can be read to determine calibration status. The bit is '0' during calibration and goes to a logic '1' when calibration is complete. This register is unique in that it can be read after POR at calibration, unlike the other registers on chip, which can't be read until calibration is complete.

DEVICE TEST

The ISLA214P50 can produce preset or user defined patterns on the digital outputs to facilitate in-situ testing. A user can pick from preset built-in patterns by writing to the output test mode field [7:4] at C0h or user defined patterns by writing to the user test mode field [2:0] at C0h. The user defined patterns should be loaded at address space C1 through D0, see the ["SPI Memory Map" on page 31](#) for more detail. The predefined patterns are shown in [Table 14](#). The test mode is enabled asynchronously to the sample clock, therefore several sample clock cycles may elapse before the data is present on the output bus.

ADDRESS 0XC0: TEST_IO**Bits 7:4 Output Test Mode**

These bits set the test mode according to table below. Other values are reserved. User test patterns loaded at 0xC1 through 0xD0 are also available by writing '1000' to [7:4] at 0xC0 and a pattern depth value to [2:0] at 0xC0. See the ["SPI Memory Map"](#).

Bits 2:0 User Test Mode

The three LSBs in this register determine the test pattern in combination with registers 0xC1 through 0xD0. See the ["SPI Memory Map"](#).

TABLE 14. OUTPUT TEST MODES

VALUE	0xC0[7:4] OUTPUT TEST MODE	WORD 1	WORD 2
0000	Off		
0001	Midscale	0x8000	N/A
0010	Positive Full-Scale	0xFFFF	N/A
0011	Negative Full-Scale	0x0000	N/A
0100	Reserved	N/A	N/A
0101	Reserved	N/A	N/A
0110	Reserved	N/A	N/A
0111	Reserved		
1000	User Pattern	user_patt1	user_patt2
1001	Reserved	N/A	N/A
1010	Ramp	N/A	N/A

ADDRESS 0XC1: USER_PATT1_LSB**ADDRESS 0XC2: USER_PATT1_MSB**

These registers define the lower and upper eight bits, respectively, of the user-defined pattern 1.

ADDRESS 0XC3: USER_PATT2_LSB**ADDRESS 0XC4: USER_PATT2_MSB**

These registers define the lower and upper eight bits, respectively, of the user-defined pattern 2

ADDRESS 0XC5: USER_PATT3_LSB**ADDRESS 0XC6: USER_PATT3_MSB**

These registers define the lower and upper eight bits, respectively, of the user-defined pattern 3.

ADDRESS 0XC7: USER_PATT4_LSB**ADDRESS 0XC8: USER_PATT4_MSB**

These registers define the lower and upper eight bits, respectively, of the user-defined pattern 4.

ADDRESS 0XC9: USER_PATT5_LSB**ADDRESS 0XCA: USER_PATT5_MSB**

These registers define the lower and upper eight bits, respectively, of the user-defined pattern 5.

ADDRESS 0XCB: USER_PATT6_LSB**ADDRESS 0XCC: USER_PATT6_MSB**

These registers define the lower and upper eight bits, respectively, of the user-defined pattern 6.

ADDRESS 0XCD: USER_PATT7_LSB**ADDRESS 0XCE: USER_PATT7_MSB**

These registers define the lower and upper eight bits, respectively, of the user-defined pattern 7.

ADDRESS 0XCF: USER_PATT8_LSB**ADDRESS 0XD0: USER_PATT8_MSB**

These registers define the lower and upper eight bits, respectively, of the user-defined pattern 8.

ADDRESS 0XFE: OFFSET/GAIN_ADJUST_ENABLE

Bit 0 at this register must be set high to enable manual adjustment of offset coarse and fine adjustments ADC0 (0x20 and 0x21), ADC1 (0x26 and 0x27) and gain medium and gain fine adjustments ADC0 (0x23 and 0x24), ADC1 (0x29 and 0x2A). It is recommended that new data be written to the offset and gain adjustment registers ADC0 (0x20, 0x21, 0x23, 0x24) and ADC1 (0x26, 0x27, 0x29, 0x2A) while Bit 0 is a '0'. Subsequently, Bit 0 should be set to '1' to allow the values written to the aforementioned registers to be used by the ADC. Bit 0 should be set to a '0' upon completion.

Digital Temperature Sensor**ADDRESS 0X4B: TEMP_COUNTER_HIGH**

Bits [2:0] of this register hold the 3 MSB's of the 11-bit temperature code.

Bit [7] of this register indicates a valid temperature_counter read was performed. A logic '1' indicates a valid read.

ADDRESS 0X4C: TEMP_COUNTER_LOW

Bits [7:0] of this register hold the lower 8 LSBs of the 11-bit temperature code.

ADDRESS 0X4D: TEMP_COUNTER_CONTROL

Bit [7] Measurement mode select bit, set to '1' for recommended PTAT mode. '0' (default) is IPTAT mode and is less accurate and not recommended.

Bit [6] Temperature counter enable bit. Set to '1' to enable.

Bit [5] Temperature counter power down bit. Set to '1' to power down temperature counter.

Bit [4] Temperature counter reset bit. Set to '1' to reset count.

Bit [3:1] Three bit frequency divider field. Sets temperature counter update rate. Update rate is proportional to ADC sample clock rate and divide ratio. A '101' updates the temp counter every ~66µs (for 250MSPS). Faster updates rates result in lower precision.

Bit [0] Select sampler bit. Set to '0'.

This set of registers provides digital access to an PTAT or IPTAT-based temperature sensor, allowing the system to estimate the temperature of the die, allowing easy access to information that can be used to decide when to recalibrate the A/D as needed.

The nominal transfer function of the temperature monitor should be estimated for each device by reading the temperature sensor at two temperatures and extrapolating a line through these two points.

A typical temperature measurement can occur as follows:

1. Write '0xCA' to address 0x4D - enable temp counter, divide = '101'.
2. Wait $\geq 132\mu\text{s}$ (at 250MSPS) - longer wait time ensures the sensor completes one valid cycle.
3. Write '0x20' to address 0x4D - power-down, disable temp counter - recommended between measurements. This ensures that the output does not change between MSB and LSB reads.
4. Read address 0x4B (MSBs).
5. Read address 0x4C (LSBs).
6. Record temp code value.
7. Write '0x20' to address 0x4D - power-down, disable temp counter.

[Contact](#) the factory for more information if needed.

SPI Memory Map

	Addr. (Hex)	Parameter Name	Bit 7 (MSB)	Bit 6	Bit 5	Bit 4	Bit 3	Bit 2	Bit 1	Bit 0 (LSB)	Def. Value (Hex)		
SPI Config/Control	00	port_config	SDO Active	LSB First	Soft Reset			Mirror (Bit 5)	Mirror (Bit 6)	Mirror (Bit 7)	00h		
	01	Reserved	Reserved										
	02	burst_end	Burst end address [7:0]									00h	
	03-07	Reserved	Reserved										
DUT Info	08	chip_id	Chip ID #									Read only	
	09	chip_version	Chip Version #									Read only	
	0A-0F	Reserved	Reserved										
Device Config/Control	10-1F	Reserved	Reserved										
	20	offset_coarse_adc0	Coarse Offset									cal. value	
	21	offset_fine_adc0	Fine Offset									cal. value	
	22	gain_coarse_adc0	Reserved					Coarse Gain					cal. value
	23	gain_medium_adc0	Medium Gain									cal. value	
	24	gain_fine_adc0	Fine Gain									cal. value	
	25	modes_adc0	Reserved					Power Down Mode ADC0 [2:0] 000 = Pin Control 001 = Normal Operation 010 = Nap 100 = Sleep Other codes = Reserved				00h NOT reset by Soft Reset	
	26	offset_coarse_adc1	Coarse Offset									cal. value	
	27	offset_fine_adc1	Fine Offset									cal. value	
	28	gain_coarse_adc1	Reserved					Coarse Gain					cal. value
	29	gain_medium_adc1	Medium Gain									cal. value	
	2A	gain_fine_adc1	Fine Gain									cal. value	
	2B	modes_adc1	Reserved					Power Down Mode ADC1 [2:0] 000 = Pin Control 001 = Normal Operation 010 = Nap 100 = Sleep Other codes = Reserved				00h NOT reset by Soft Reset	
	2C-2F	Reserved	Reserved										
	I2E Control and Status	30	IE_status				Reserved		I2E Settled	Low AC RMS Power	Low RMS Power	Read only	
31		IE_control			Enable Notch Filter	Disable Offset	Disable Gain	Disable Skew	Freeze	Run	20h		
32		IE_static_control	Reserved must be set to 0		Skip coarse adj.	Reserved, must be set to 0				Should be set to 1	01h		
33-49		Reserved	Reserved										
4A		IE_power_down							Notch Filter Power Down	I2E Power Down	03h		
4B		temp_counter_high						Temp Counter [10:8]				Read only	
4C		temp_counter_low	Temp Counter [7:0]									Read only	
4D		temp_counter_control		Enable	PD	Reset	Divider [2:0]			Select	00h		
4E-4F		Reserved	Reserved										
50		IE_rms_power_threshold_lsb	RMS Power Threshold, LSBs [7:0]									00h	

SPI Memory Map (Continued)

	Addr. (Hex)	Parameter Name	Bit 7 (MSB)	Bit 6	Bit 5	Bit 4	Bit 3	Bit 2	Bit 1	Bit 0 (LSB)	Def. Value (Hex)	
I2E Control and Status	51	IE_rms_power_threshold_msb	RMS Power Threshold, MSBs [15:8]								10h	
	52	IE_rms_hysteresis	RMS Power Hysteresis								FFh	
	53	IE_ac_rms_power_threshold_lsb	AC Power Threshold, LSBs, [7:0]								50h	
	54	IE_ac_rms_power_threshold_msb	AC Power Threshold, MSBs, [15:8]								00h	
	55	IE_ac_rms_hysteresis	AC RMS Power Hysteresis								10h	
	56-5F	Reserved	Reserved									
	60	coarse_offset_init	Coarse Offset Initialization value								80h	
	61	fine_offset_init	Fine Offset Initialization value								80h	
	62	medium_gain_init	Medium Gain Initialization value								80h	
	63	fine_gain_init	Fine Gain Initialization value								80h	
	64	sample_time_skew_init	Sample Time Skew Initialization value								80h	
	65-6F	Reserved	Reserved									
DeviceConfig/Control	70	skew_diff	Differential Skew								80h	
	71	phase_slip	Reserved								Next Clock Edge	00h
	72	clock_divide								Clock Divide [2:0] 000 = Pin Control 001 = divide by 1 010 = divide by 2 Other codes = Reserved	00h NOT reset by Soft Reset	
	73	output_mode_A	Output Mode [7:5] 000 = LVDS 3mA (Default) 001 = LVDS 2mA 100 = LVCMOS Other codes = Reserved								Output Format [2:0] 000 = Two's Complement (Default) 010 = Gray Code 100 = Offset Binary Other codes = Reserved	00h NOT reset by Soft Reset
	74	output_mode_B		DLL Range 0 = Fast 1 = Slow (Default = '0')		Reserved						00h NOT reset by Soft Reset
	75-BF	Reserved	Reserved									
	A4	dll_ctrl_upper_adc0	Consult Factory								cal. value	
	A5	dll_ctrl_lower_adc0	Consult Factory								cal. value	
	A6	dll_status_upper_adc0	Consult Factory								Read only	
	A7	dll_status_lower_adc0	Consult Factory								Read only	
	A8	dll_ctrl_upper_adc1	Consult Factory								cal. value	
	A9	dll_ctrl_lower_adc1	Consult Factory								cal. value	
AA	dll_status_upper_adc1	Consult Factory								Read only		
AB	dll_status_lower_adc1	Consult Factory								Read only		
AC-B5	Reserved	Reserved										
B6	Cal_Status	Reserved								Calibration Done	Read only	
B7-BF	Reserved	Reserved										

SPI Memory Map (Continued)

	Addr. (Hex)	Parameter Name	Bit 7 (MSB)	Bit 6	Bit 5	Bit 4	Bit 3	Bit 2	Bit 1	Bit 0 (LSB)	Def. Value (Hex)
Device Test	C0	test_io	Output Test Mode (DDR) [7:4]				User Test Mode (DDR) [2:0]				00h
			0 = Off (Note 17) 1 = Midscale Short 2 = +FS Short 3 = -FS Short 4 = Checker Board output - 0xAAAA, 0x5555 DDR 5 = Reserved 6 = Reserved 7 = 0xFFFF, 0x0000 all on pattern, DDR Word Toggle 8 = User Pattern (1 to 8 deep, DDR, MSB justified) 9 = Reserved 10 = Ramp 11-15 = Reserved				0 = Cycle pattern 1 through 2 1 = Cycle pattern 1 through 4 2 = Cycle pattern 1 through 6 3 = Cycle pattern 1 through 8 4-7 = NA				
	C1	user_patt1_lsb	B7	B6	B5	B4	B3	B2	B1	B0	00h
	C2	user_patt1_msb	B15	B14	B13	B12	B11	B10	B9	B8	00h
	C3	user_patt2_lsb	B7	B6	B5	B4	B3	B2	B1	B0	00h
	C4	user_patt2_msb	B15	B14	B13	B12	B11	B10	B9	B8	00h
	C5	user_patt3_lsb	B7	B6	B5	B4	B3	B2	B1	B0	00h
	C6	user_patt3_msb	B15	B14	B13	B12	B11	B10	B9	B8	00h
	C7	user_patt4_lsb	B7	B6	B5	B4	B3	B2	B1	B0	00h
	C8	user_patt4_msb	B15	B14	B13	B12	B11	B10	B9	B8	00h
	C9	user_patt5_lsb	B7	B6	B5	B4	B3	B2	B1	B0	00h
	CA	user_patt5_msb	B15	B14	B13	B12	B11	B10	B9	B8	00h
	CB	user_patt6_lsb	B7	B6	B5	B4	B3	B2	B1	B0	00h
	CC	user_patt6_msb	B15	B14	B13	B12	B11	B10	B9	B8	00h
	CD	user_patt7_lsb	B7	B6	B5	B4	B3	B2	B1	B0	00h
	CE	user_patt7_msb	B15	B14	B13	B12	B11	B10	B9	B8	00h
	CF	user_patt8_lsb	B7	B6	B5	B4	B3	B2	B1	B0	00h
D0	user_patt8_msb	B15	B14	B13	B12	B11	B10	B9	B8	00h	
D1-FD	Reserved	Reserved									
FE	Offset/Gain_Adjust_Enable	Reserved								Enable "1" = Enable	00h
FF	Reserved	Reserved									

NOTE:

17. During Calibration xCCCC (MSB justified) is presented at the output data bus, toggling on the LSB (and higher) data bits occurs at completion of calibration. This behavior can be used as an option to monitoring over range to determine calibration state.

Equivalent Circuits

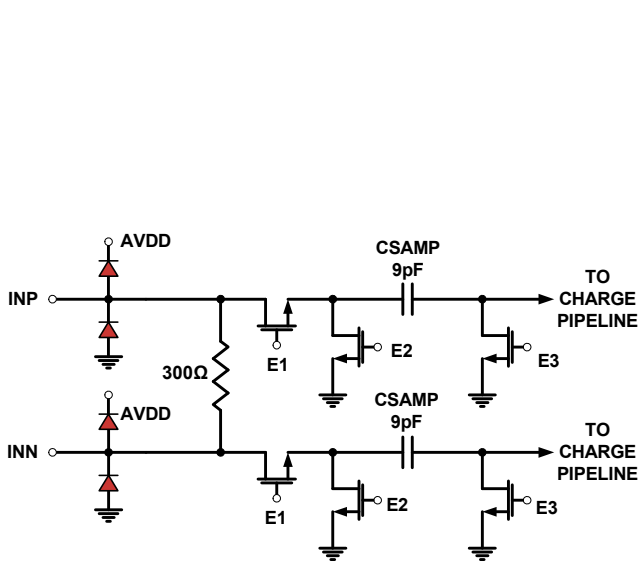

FIGURE 43. ANALOG INPUTS

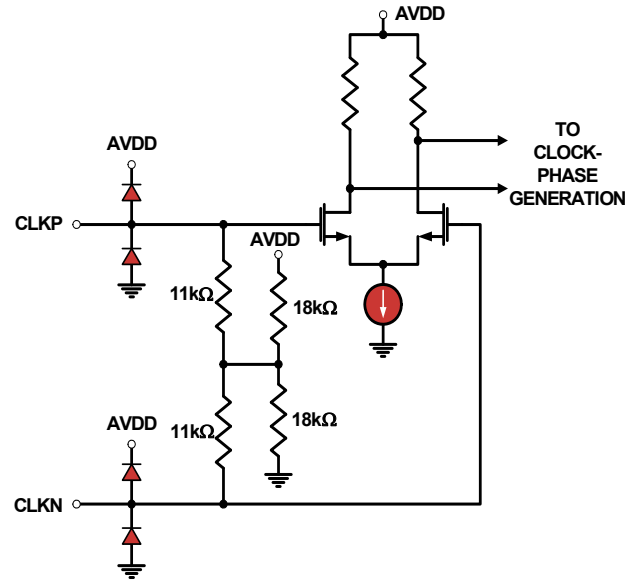

FIGURE 44. CLOCK INPUTS

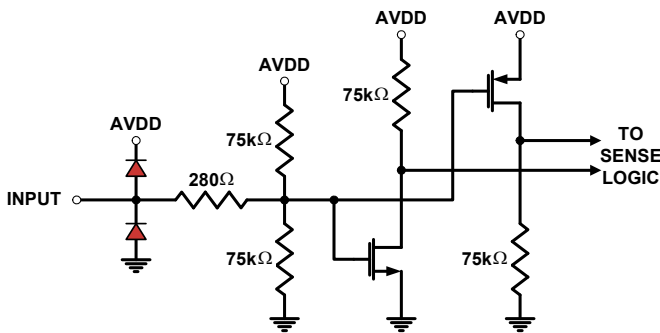

FIGURE 45. TRI-LEVEL DIGITAL INPUTS

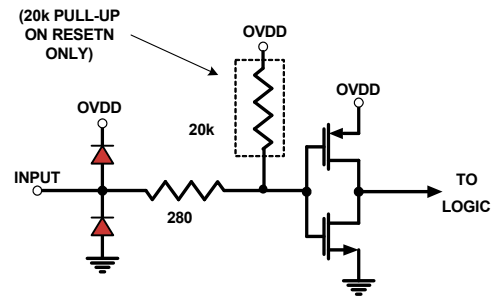

FIGURE 46. DIGITAL INPUTS

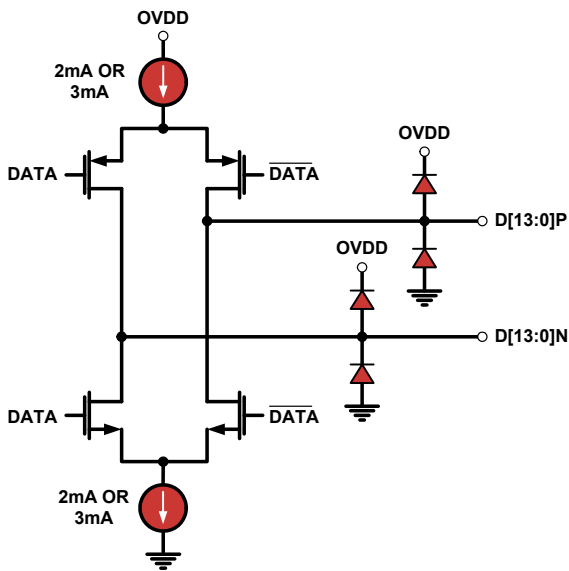

FIGURE 47. LVDS OUTPUTS

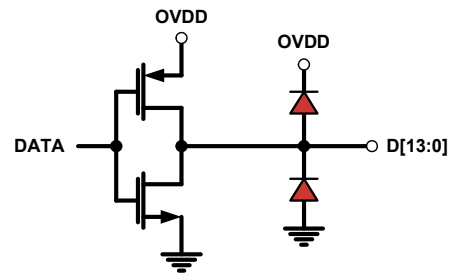

FIGURE 48. CMOS OUTPUTS

Equivalent Circuits (Continued)

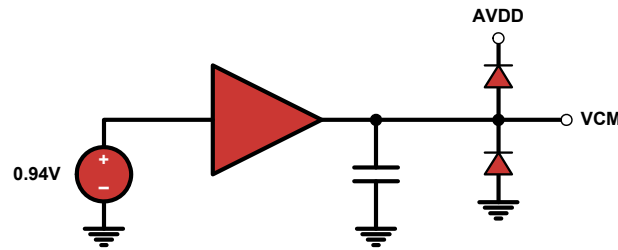

FIGURE 49. VCM_OUT OUTPUT

A/D Evaluation Platform

Renesas offers an A/D evaluation platform which can be used to evaluate any of the Renesas high speed A/D products. The platform consists of an FPGA based data capture motherboard and a family of A/D daughter cards. This USB based platform allows a user to quickly evaluate the A/D's performance at a user's specific application frequency requirements. More information is available on our [website](#).

Layout Considerations

Split Ground and Power Planes

Data converters operating at high sampling frequencies require extra care in PC board layout. Many complex board designs benefit from isolating the analog and digital sections. Analog supply and ground planes should be laid out under signal and clock inputs. Locate the digital planes under outputs and logic pins. Grounds should be joined under the chip.

Clock Input Considerations

Use matched transmission lines to the transformer inputs for the analog input and clock signals. Locate transformers and terminations as close to the chip as possible.

Exposed Paddle

The exposed paddle must be electrically connected to analog ground (AVSS) and should be connected to a large copper plane using numerous vias for optimal thermal performance.

Bypass and Filtering

Bulk capacitors should have low equivalent series resistance. Tantalum is a good choice. For best performance, keep ceramic bypass capacitors very close to device pins. Longer traces increase inductance, resulting in diminished dynamic performance and accuracy. Make sure that connections to ground are direct and low impedance. Avoid forming ground loops.

LVDS Outputs

Output traces and connections must be designed for 50Ω (100Ω differential) characteristic impedance. Keep traces direct and minimize bends where possible. Avoid crossing ground and power-plane breaks with signal traces.

LVC MOS Outputs

Output traces and connections must be designed for 50Ω characteristic impedance.

Unused Inputs

Standard logic inputs (RESETN, CSB, SCLK, SDIO, SDO) which are not operated do not require connection to ensure optimal A/D performance. These inputs can be left floating if they are not used. Tri-level inputs (NAPSLP) accept a floating input as a valid state, and therefore should be biased according to the desired functionality.

Definitions

Analog Input Bandwidth is the analog input frequency at which the spectral output power at the fundamental frequency (as determined by FFT analysis) is reduced by 3dB from its full-scale low-frequency value. This is also referred to as Full Power Bandwidth.

Aperture Delay or Sampling Delay is the time required after the rise of the clock input for the sampling switch to open, at which time the signal is held for conversion.

Aperture Jitter is the RMS variation in aperture delay for a set of samples.

Clock Duty Cycle is the ratio of the time the clock wave is at logic high to the total time of one clock period.

Differential Non-Linearity (DNL) is the deviation of any code width from an ideal 1 LSB step.

Effective Number of Bits (ENOB) is an alternate method of specifying Signal to Noise-and-Distortion Ratio (SINAD). In dB, it is calculated as: $ENOB = (SINAD - 1.76)/6.02$

Gain Error is the ratio of the difference between the voltages that cause the lowest and highest code transitions to the full-scale voltage less 2 LSB. It is typically expressed in percent.

I2E The Interleave Engine. This highly configurable circuitry performs estimates of offset, gain, and sample time skew mismatches between the core converters, and updates analog adjustments for each to minimize interleave spurs.

Integral Non-Linearity (INL) is the maximum deviation of the A/D's transfer function from a best fit line determined by a least squares curve fit of that transfer function, measured in units of LSBs.

Least Significant Bit (LSB) is the bit that has the smallest value or weight in a digital word. Its value in terms of input voltage is $V_{FS}/(2^N-1)$ where N is the resolution in bits.

Missing Codes are output codes that are skipped and never appear at the A/D output. These codes cannot be reached with any input value.

Most Significant Bit (MSB) is the bit that has the largest value or weight.

Pipeline Delay is the number of clock cycles between the initiation of a conversion and the appearance at the output pins of the data.

Power Supply Rejection Ratio (PSRR) is the ratio of the observed magnitude of a spur in the A/D FFT, caused by an AC signal superimposed on the power supply voltage.

Signal to Noise-and-Distortion (SINAD) is the ratio of the RMS signal amplitude to the RMS sum of all other spectral components below one half the clock frequency, including harmonics but excluding DC.

Signal-to-Noise Ratio (without Harmonics) is the ratio of the RMS signal amplitude to the RMS sum of all other spectral components below one-half the sampling frequency, excluding harmonics and DC.

SNR and SINAD are either given in units of dB when the power of the fundamental is used as the reference, or dBFS (dB to full scale) when the converter's full-scale input power is used as the reference.

Spurious-Free-Dynamic Range (SFDR) is the ratio of the RMS signal amplitude to the RMS value of the largest spurious spectral component. The largest spurious spectral component may or may not be a harmonic.

Revision History

The revision history provided is for informational purposes only and is believed to be accurate, but not warranted. Please go to web to make sure you have the latest Rev.

DATE	REVISION	CHANGE
Nov 29, 2018	FN7571.3	Updated formatting. Added related literature section. Added ESD ratings for HBM and CDM. Updated revision history. Removed About Intersil section. Updated disclaimer.
Nov 21, 2012	FN7571.2	Improved accuracy and clarity of datasheet throughout.
Mar 14, 2011	FN7571.1	Removed coming soon part ISLA214P50IR1Z from "Ordering Information" (not being offered). Page 1 Features changed "75fS" to "75fs". Updated ordering Eval board name from "ISLA214P50EVAL" to "ISLA214P50IR72EV1Z". Updated Temperature Calibration Curves. Added paragraph to "Clock Input" on page 19.
Mar 1, 2011		Removed 100% Matte Tin Plate w/Anneal-e3 lead finish note from "Ordering Information" due to both parts having NiPdAu plate-e4 termination finish.
Feb 28, 2011		Added Note reference to MIN and MAX columns of "I2E Specifications" table on page 10.
Feb 8, 2011	FN7571.0	Initial Release

Package Outline Drawing

For the most recent package outline drawing, see [L72.10x10E](#).

L72.10x10E

72 LEAD QUAD FLAT NO-LEAD PLASTIC PACKAGE

Rev 0, 11/09

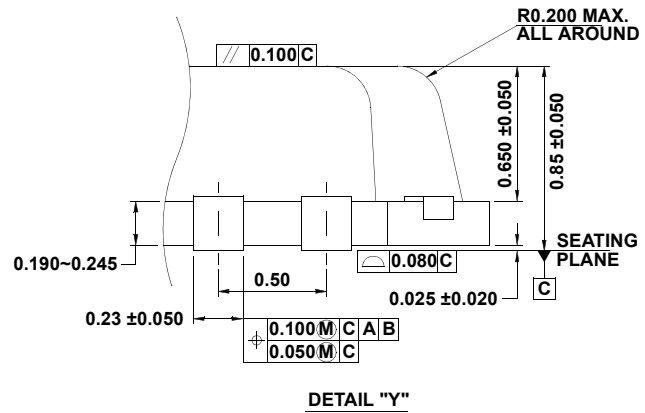
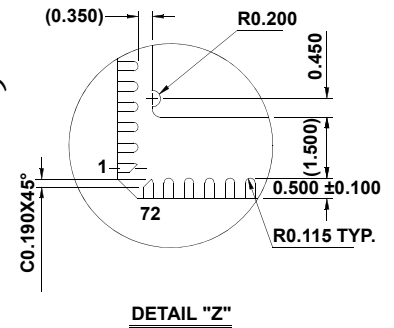
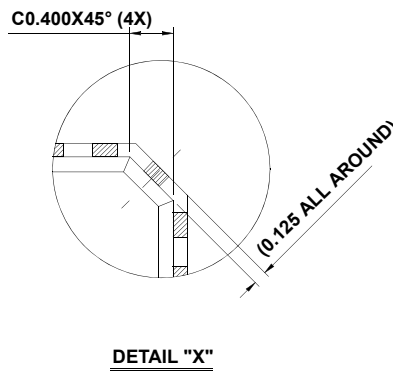
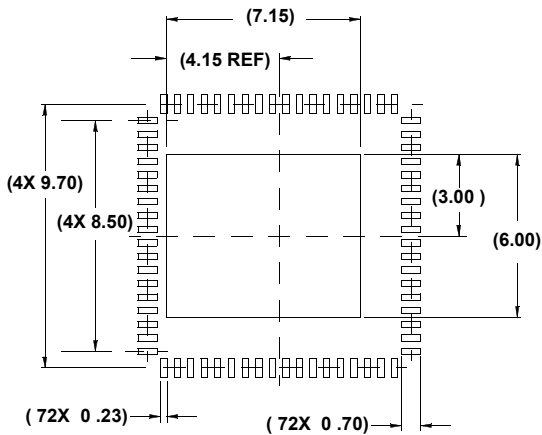
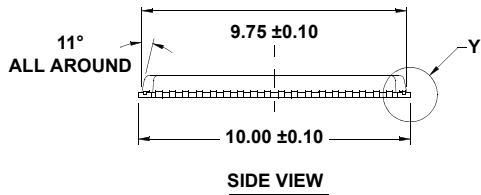
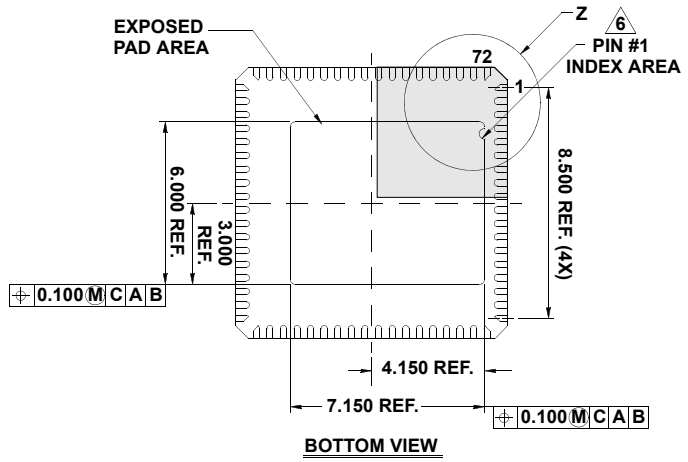
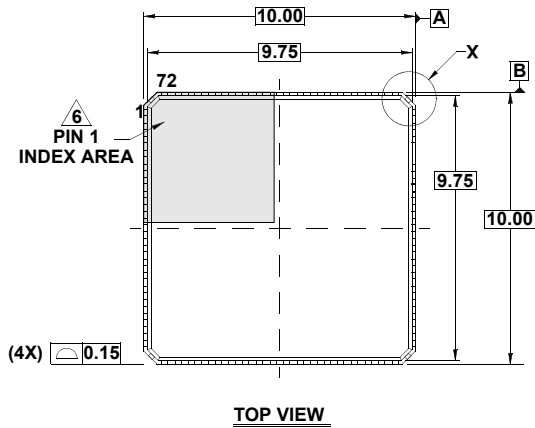

NOTES:

1. Dimensions are in millimeters.
Dimensions in () for Reference Only.
2. Dimensioning and tolerancing conform to ANSI Y14.5m-1994.
3. Unless otherwise specified, tolerance : Decimal ± 0.10
Angular $\pm 2.50^\circ$
4. Dimension applies to the metallized terminal and is measured between 0.015mm and 0.30mm from the terminal tip.
5. Tiebar shown (if present) is a non-functional feature.
6. The configuration of the pin #1 identifier is optional, but must be located within the zone indicated. The pin #1 identifier may be either a mold or mark feature.
7. Package outline compliant to JESD-M0220.

Notice

1. Descriptions of circuits, software and other related information in this document are provided only to illustrate the operation of semiconductor products and application examples. You are fully responsible for the incorporation or any other use of the circuits, software, and information in the design of your product or system. Renesas Electronics disclaims any and all liability for any losses and damages incurred by you or third parties arising from the use of these circuits, software, or information.
2. Renesas Electronics hereby expressly disclaims any warranties against and liability for infringement or any other claims involving patents, copyrights, or other intellectual property rights of third parties, by or arising from the use of Renesas Electronics products or technical information described in this document, including but not limited to, the product data, drawings, charts, programs, algorithms, and application examples.
3. No license, express, implied or otherwise, is granted hereby under any patents, copyrights or other intellectual property rights of Renesas Electronics or others.
4. You shall not alter, modify, copy, or reverse engineer any Renesas Electronics product, whether in whole or in part. Renesas Electronics disclaims any and all liability for any losses or damages incurred by you or third parties arising from such alteration, modification, copying or reverse engineering.
5. Renesas Electronics products are classified according to the following two quality grades: "Standard" and "High Quality". The intended applications for each Renesas Electronics product depends on the product's quality grade, as indicated below.
"Standard": Computers; office equipment; communications equipment; test and measurement equipment; audio and visual equipment; home electronic appliances; machine tools; personal electronic equipment; industrial robots; etc.
"High Quality": Transportation equipment (automobiles, trains, ships, etc.); traffic control (traffic lights); large-scale communication equipment; key financial terminal systems; safety control equipment; etc.
Unless expressly designated as a high reliability product or a product for harsh environments in a Renesas Electronics data sheet or other Renesas Electronics document, Renesas Electronics products are not intended or authorized for use in products or systems that may pose a direct threat to human life or bodily injury (artificial life support devices or systems; surgical implantations; etc.), or may cause serious property damage (space system; undersea repeaters; nuclear power control systems; aircraft control systems; key plant systems; military equipment; etc.). Renesas Electronics disclaims any and all liability for any damages or losses incurred by you or any third parties arising from the use of any Renesas Electronics product that is inconsistent with any Renesas Electronics data sheet, user's manual or other Renesas Electronics document.
6. When using Renesas Electronics products, refer to the latest product information (data sheets, user's manuals, application notes, "General Notes for Handling and Using Semiconductor Devices" in the reliability handbook, etc.), and ensure that usage conditions are within the ranges specified by Renesas Electronics with respect to maximum ratings, operating power supply voltage range, heat dissipation characteristics, installation, etc. Renesas Electronics disclaims any and all liability for any malfunctions, failure or accident arising out of the use of Renesas Electronics products outside of such specified ranges.
7. Although Renesas Electronics endeavors to improve the quality and reliability of Renesas Electronics products, semiconductor products have specific characteristics, such as the occurrence of failure at a certain rate and malfunctions under certain use conditions. Unless designated as a high reliability product or a product for harsh environments in a Renesas Electronics data sheet or other Renesas Electronics document, Renesas Electronics products are not subject to radiation resistance design. You are responsible for implementing safety measures to guard against the possibility of bodily injury, injury or damage caused by fire, and/or danger to the public in the event of a failure or malfunction of Renesas Electronics products, such as safety design for hardware and software, including but not limited to redundancy, fire control and malfunction prevention, appropriate treatment for aging degradation or any other appropriate measures. Because the evaluation of microcomputer software alone is very difficult and impractical, you are responsible for evaluating the safety of the final products or systems manufactured by you.
8. Please contact a Renesas Electronics sales office for details as to environmental matters such as the environmental compatibility of each Renesas Electronics product. You are responsible for carefully and sufficiently investigating applicable laws and regulations that regulate the inclusion or use of controlled substances, including without limitation, the EU RoHS Directive, and using Renesas Electronics products in compliance with all these applicable laws and regulations. Renesas Electronics disclaims any and all liability for damages or losses occurring as a result of your noncompliance with applicable laws and regulations.
9. Renesas Electronics products and technologies shall not be used for or incorporated into any products or systems whose manufacture, use, or sale is prohibited under any applicable domestic or foreign laws or regulations. You shall comply with any applicable export control laws and regulations promulgated and administered by the governments of any countries asserting jurisdiction over the parties or transactions.
10. It is the responsibility of the buyer or distributor of Renesas Electronics products, or any other party who distributes, disposes of, or otherwise sells or transfers the product to a third party, to notify such third party in advance of the contents and conditions set forth in this document.
11. This document shall not be reprinted, reproduced or duplicated in any form, in whole or in part, without prior written consent of Renesas Electronics.
12. Please contact a Renesas Electronics sales office if you have any questions regarding the information contained in this document or Renesas Electronics products.

(Note 1) "Renesas Electronics" as used in this document means Renesas Electronics Corporation and also includes its directly or indirectly controlled subsidiaries.

(Note 2) "Renesas Electronics product(s)" means any product developed or manufactured by or for Renesas Electronics.

(Rev.4.0-1 November 2017)



SALES OFFICES

Renesas Electronics Corporation

<http://www.renesas.com>

Refer to "<http://www.renesas.com/>" for the latest and detailed information.

Renesas Electronics Corporation

TOYOSU FORESIA, 3-2-24 Toyosu, Koto-ku, Tokyo 135-0061, Japan

Renesas Electronics America Inc.

1001 Murphy Ranch Road, Milpitas, CA 95035, U.S.A.
Tel: +1-408-432-8888, Fax: +1-408-434-5351

Renesas Electronics Canada Limited

9251 Yonge Street, Suite 8309 Richmond Hill, Ontario Canada L4C 9T3
Tel: +1-905-237-2004

Renesas Electronics Europe Limited

Dukes Meadow, Millboard Road, Bourne End, Buckinghamshire, SL8 5FH, U.K
Tel: +44-1628-651-700

Renesas Electronics Europe GmbH

Arcadiastrasse 10, 40472 Düsseldorf, Germany
Tel: +49-211-6503-0, Fax: +49-211-6503-1327

Renesas Electronics (China) Co., Ltd.

Room 1709 Quantum Plaza, No.27 ZhichunLu, Haidian District, Beijing, 100191 P. R. China
Tel: +86-10-8235-1155, Fax: +86-10-8235-7679

Renesas Electronics (Shanghai) Co., Ltd.

Unit 301, Tower A, Central Towers, 555 Langao Road, Putuo District, Shanghai, 200333 P. R. China
Tel: +86-21-2226-0888, Fax: +86-21-2226-0999

Renesas Electronics Hong Kong Limited

Unit 1601-1611, 16/F., Tower 2, Grand Century Place, 193 Prince Edward Road West, Mongkok, Kowloon, Hong Kong
Tel: +852-2265-6688, Fax: +852 2886-9022

Renesas Electronics Taiwan Co., Ltd.

13F, No. 363, Fu Shing North Road, Taipei 10543, Taiwan
Tel: +886-2-8175-9600, Fax: +886 2-8175-9670

Renesas Electronics Singapore Pte. Ltd.

80 Bendemeer Road, Unit #06-02 Hyflux Innovation Centre, Singapore 339949
Tel: +65-6213-0200, Fax: +65-6213-0300

Renesas Electronics Malaysia Sdn.Bhd.

Unit 1207, Block B, Menara Amcorp, Amcorp Trade Centre, No. 18, Jln Persiaran Barat, 46050 Petaling Jaya, Selangor Darul Ehsan, Malaysia
Tel: +60-3-7955-9390, Fax: +60-3-7955-9510

Renesas Electronics India Pvt. Ltd.

No.777C, 100 Feet Road, HAL 2nd Stage, Indiranagar, Bangalore 560 038, India
Tel: +91-80-67208700, Fax: +91-80-67208777

Renesas Electronics Korea Co., Ltd.

17F, KAMCO Yangjae Tower, 262, Gangnam-daero, Gangnam-gu, Seoul, 06265 Korea
Tel: +82-2-558-3737, Fax: +82-2-558-5338

Компания «Океан Электроники» предлагает заключение долгосрочных отношений при поставках импортных электронных компонентов на взаимовыгодных условиях!

Наши преимущества:

- Поставка оригинальных импортных электронных компонентов напрямую с производств Америки, Европы и Азии, а так же с крупнейших складов мира;
- Широкая линейка поставок активных и пассивных импортных электронных компонентов (более 30 млн. наименований);
- Поставка сложных, дефицитных, либо снятых с производства позиций;
- Оперативные сроки поставки под заказ (от 5 рабочих дней);
- Экспресс доставка в любую точку России;
- Помощь Конструкторского Отдела и консультации квалифицированных инженеров;
- Техническая поддержка проекта, помощь в подборе аналогов, поставка прототипов;
- Поставка электронных компонентов под контролем ВП;
- Система менеджмента качества сертифицирована по Международному стандарту ISO 9001;
- При необходимости вся продукция военного и аэрокосмического назначения проходит испытания и сертификацию в лаборатории (по согласованию с заказчиком);
- Поставка специализированных компонентов военного и аэрокосмического уровня качества (Xilinx, Altera, Analog Devices, Intersil, Interpoint, Microsemi, Actel, Aeroflex, Peregrine, VPT, Syfer, Eurofarad, Texas Instruments, MS Kennedy, Miteq, Cobham, E2V, MA-COM, Hittite, Mini-Circuits, General Dynamics и др.);

Компания «Океан Электроники» является официальным дистрибьютором и эксклюзивным представителем в России одного из крупнейших производителей разъемов военного и аэрокосмического назначения «JONHON», а так же официальным дистрибьютором и эксклюзивным представителем в России производителя высокотехнологичных и надежных решений для передачи СВЧ сигналов «FORSTAR».



JONHON

«JONHON» (основан в 1970 г.)

Разъемы специального, военного и аэрокосмического назначения:

(Применяются в военной, авиационной, аэрокосмической, морской, железнодорожной, горно- и нефтедобывающей отраслях промышленности)

«FORSTAR» (основан в 1998 г.)

ВЧ соединители, коаксиальные кабели,
кабельные сборки и микроволновые компоненты:

(Применяются в телекоммуникациях гражданского и специального назначения, в средствах связи, РЛС, а так же военной, авиационной и аэрокосмической отраслях промышленности).



Телефон: 8 (812) 309-75-97 (многоканальный)

Факс: 8 (812) 320-03-32

Электронная почта: ocean@oceanchips.ru

Web: <http://oceanchips.ru/>

Адрес: 198099, г. Санкт-Петербург, ул. Калинина, д. 2, корп. 4, лит. А